



extension  
conversion



Submitted in fulfilment of part of the requirements for the degree of Masters in Architecture (Professional) in the Faculty of Engineering, Built Environment and Information Technology, the University of Pretoria, South Africa, 2009.

Study Leader : Nicholas Clarke  
Course Co-ordinator : Prof. Karel Bakker

by Maretha Perold\_27459595

# music<sup>2</sup>

place of music  
experience of music

*established*  
*intensified*

extension & conversion of the department of music of the university of pretoria



UNIVERSITEIT VAN PRETORIA  
UNIVERSITY OF PRETORIA  
YUNIBESITHI YA PRETORIA

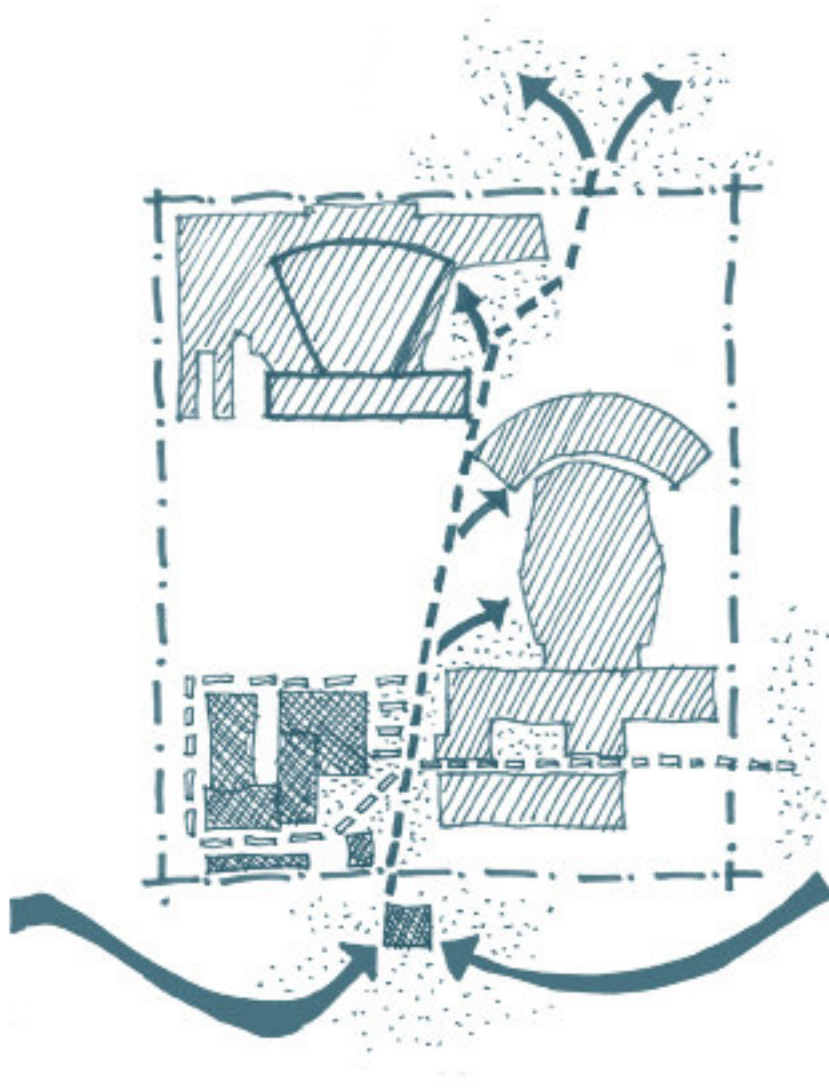

brief

additions to - integration of - UP music department



UNIVERSITEIT VAN PRETORIA  
UNIVERSITY OF PRETORIA  
YUNIBESITHI YA PRETORIA

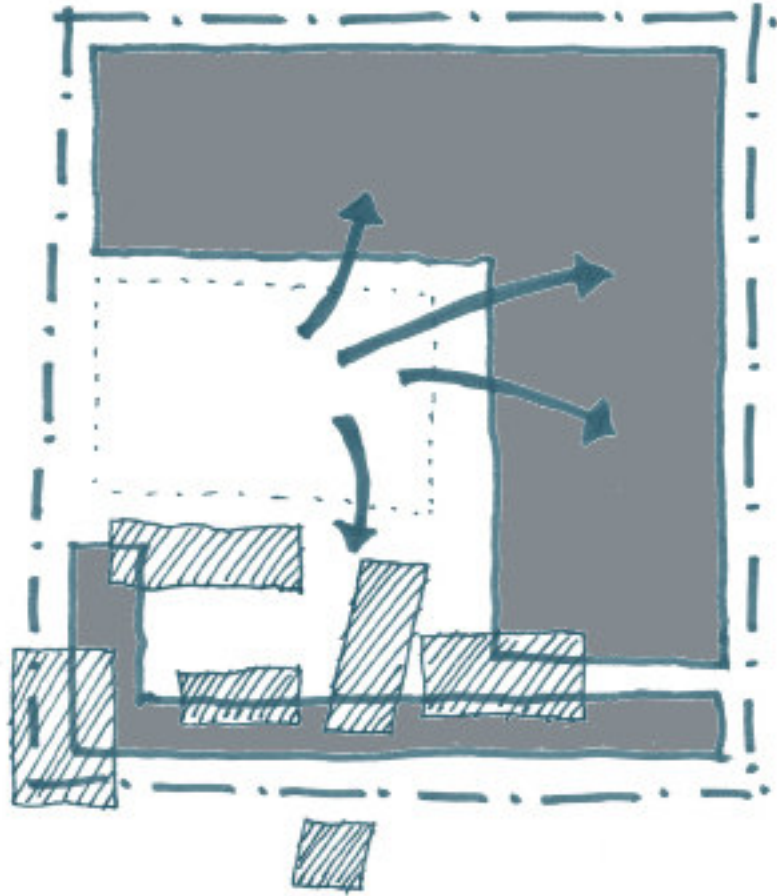

music2 - music established - music intensified

response

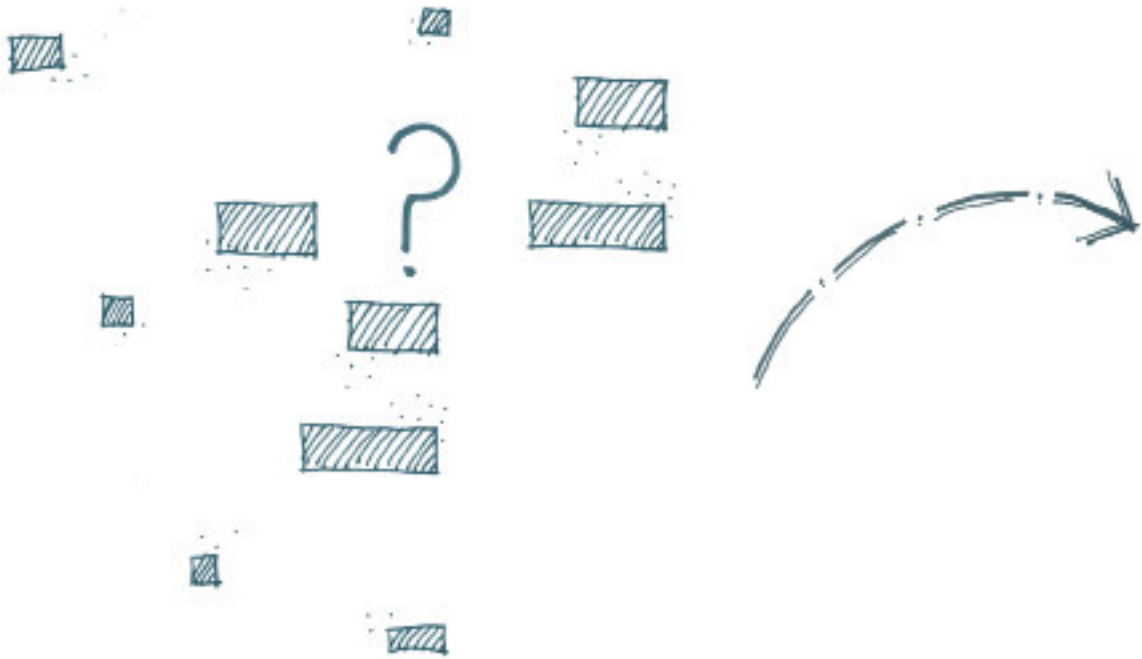

method

extension - conversion

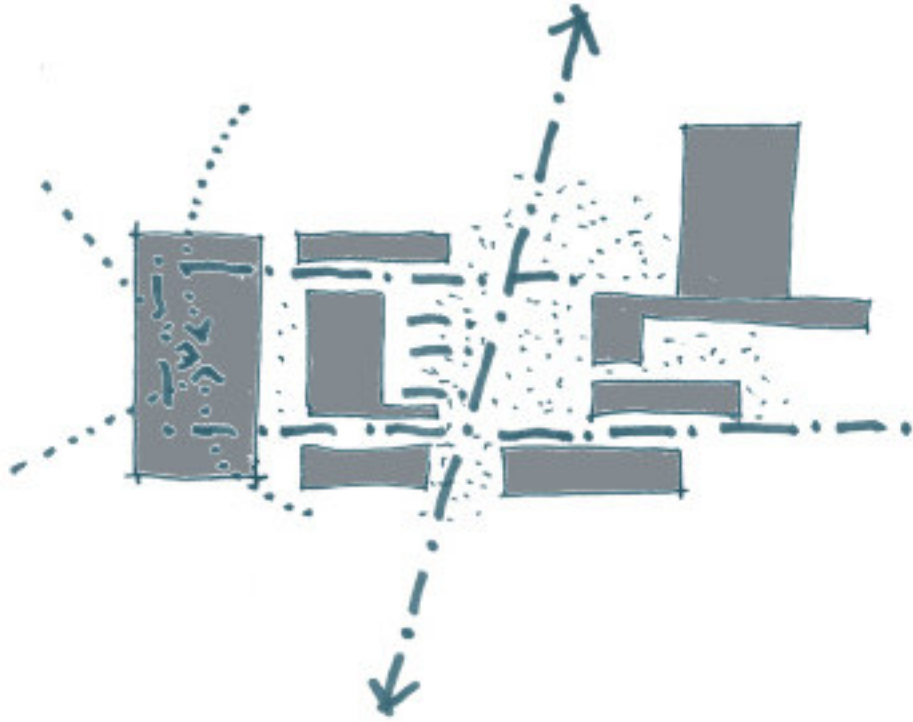

contextually - functionally - socially

method

new building - new place  
- precinct serving music -  
linked to campus & public

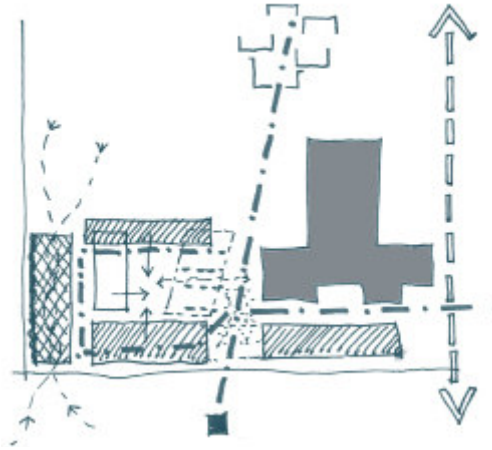

## functional

all-inclusive program -  
emphasising process of  
music - preparation &  
performance

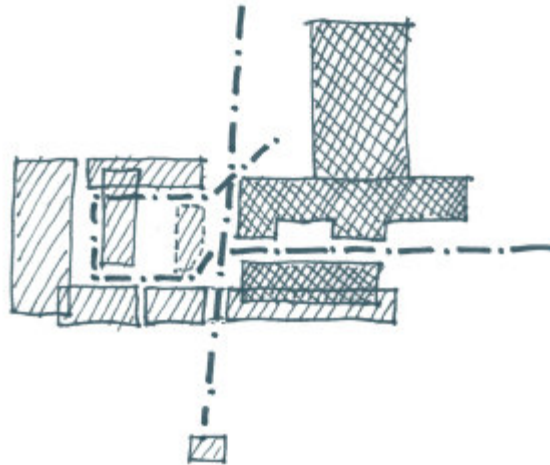

## social

increased variety of  
people & places -  
definition of programmed  
& social spaces

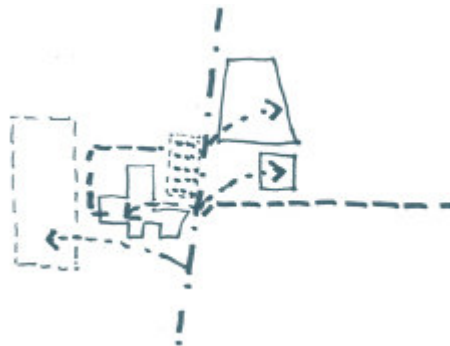



# conversion

## contextual

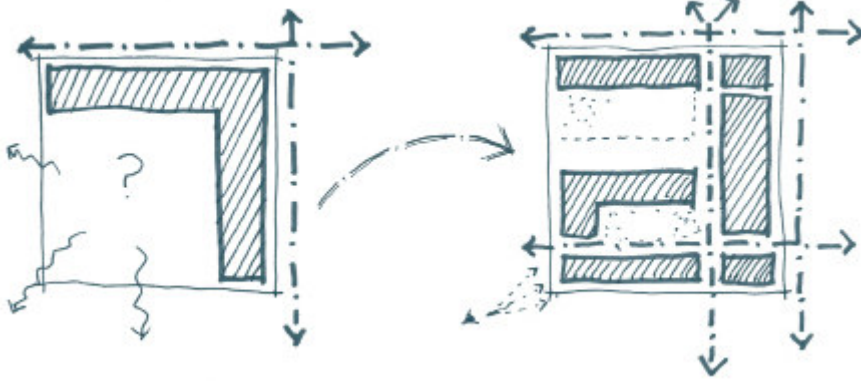

undefined lost spaces  
- integrated responsive places

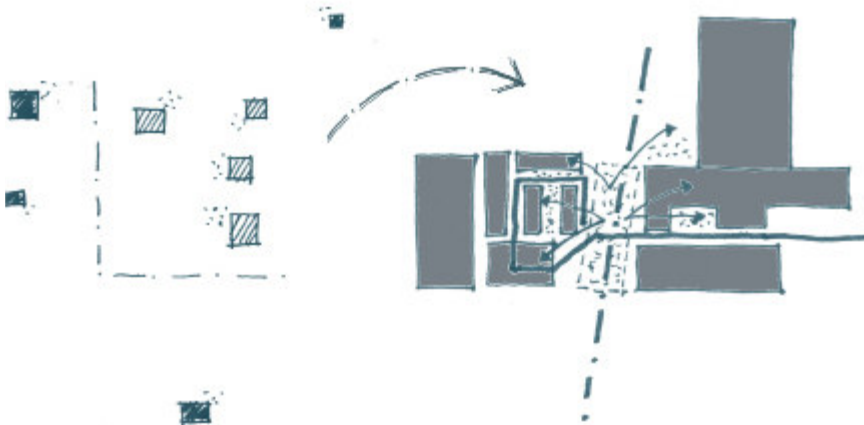

## functional

isolated monofunctional venues - integrated cross-programmed spaces

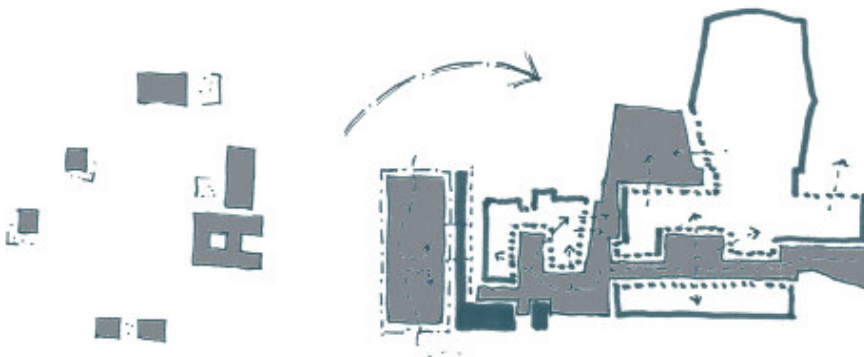

## social

internal programmed & external undefined spaces  
- system of programmed, transition & social spaces



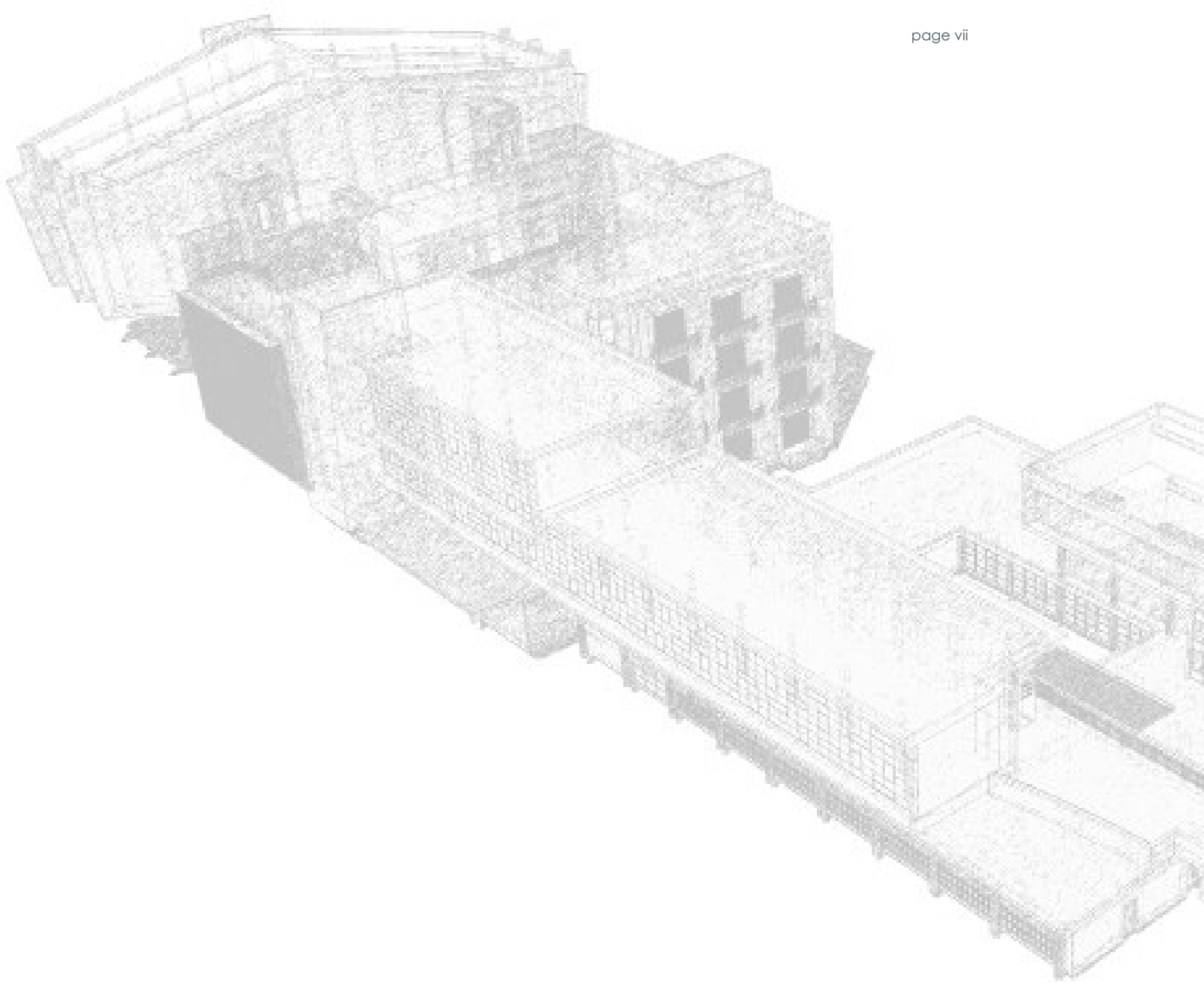

new building - new place  
- precinct serving music -  
linked to campus & public

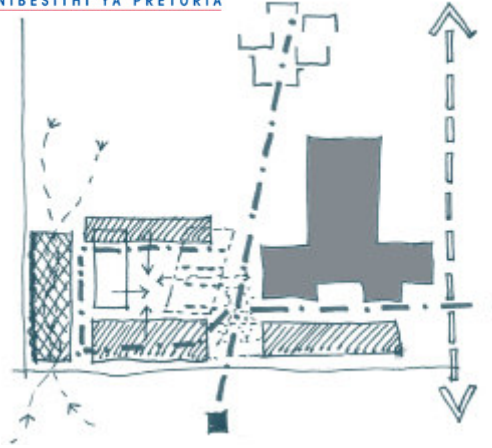

## functional

all-inclusive program -  
emphasising process of  
music - preparation &  
performance

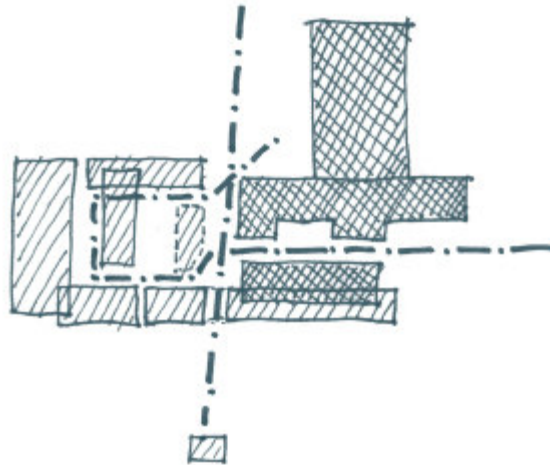

## social

increased variety of  
people & places -  
definition of programmed  
& social spaces

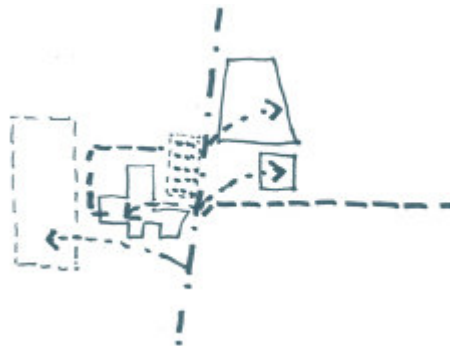

new building - new place  
- precinct serving music -  
linked to campus & public

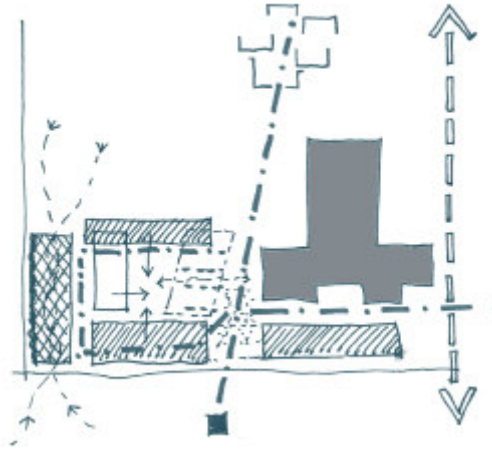

## functional

all-inclusive program -  
emphasising process of  
music - preparation &  
performance

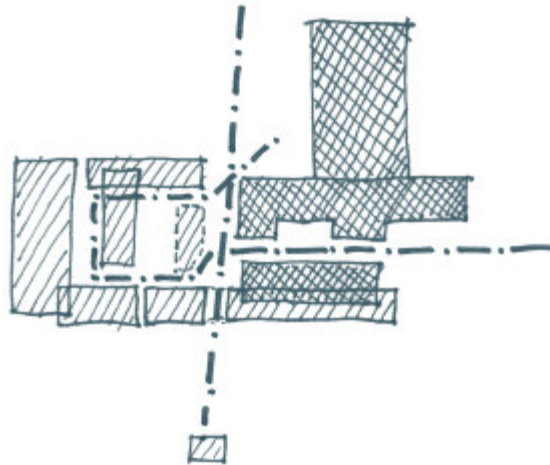

## social

increased variety of  
people & places -  
definition of programmed  
& social spaces

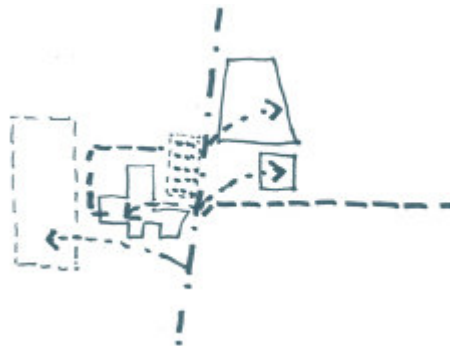

# conversion

## contextual

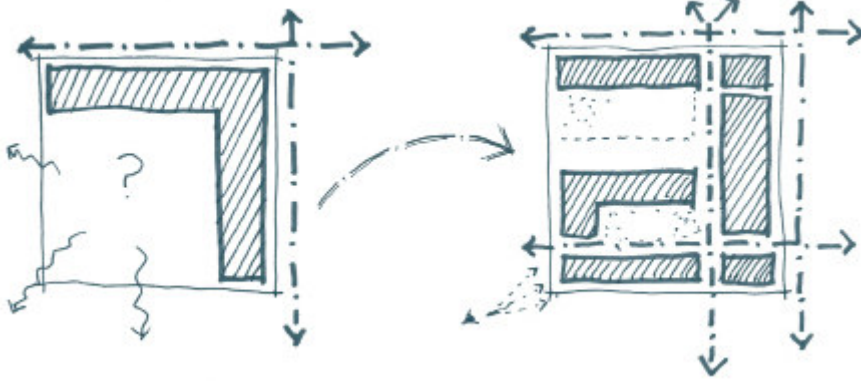

undefined lost spaces  
- integrated responsive places

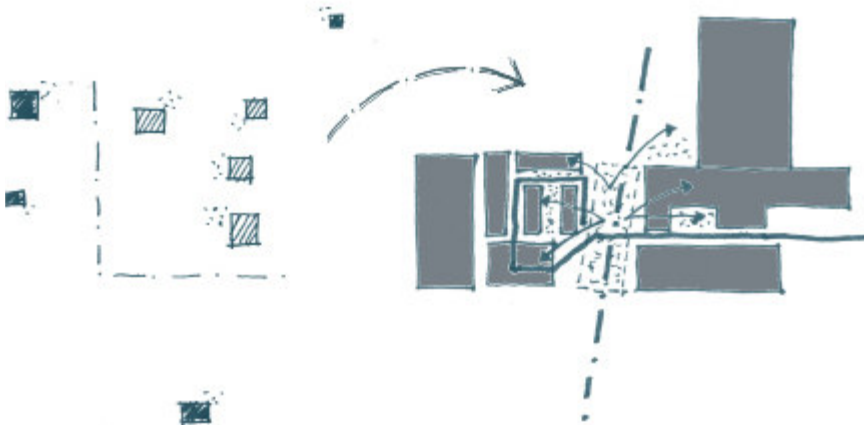

## functional

isolated monofunctional venues - integrated cross-programmed spaces

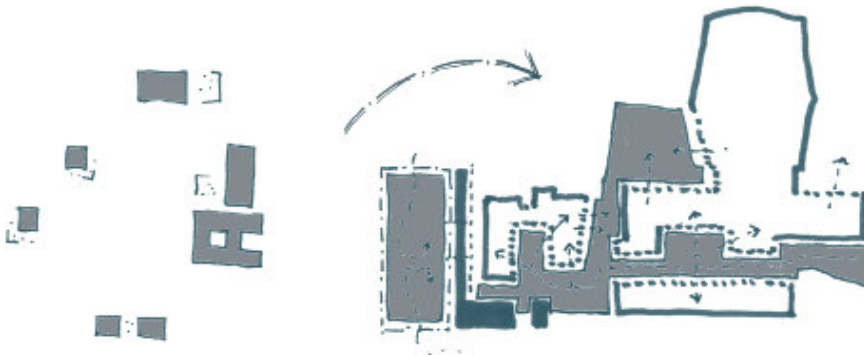

## social

internal programmed & external undefined spaces  
- system of programmed, transition & social spaces



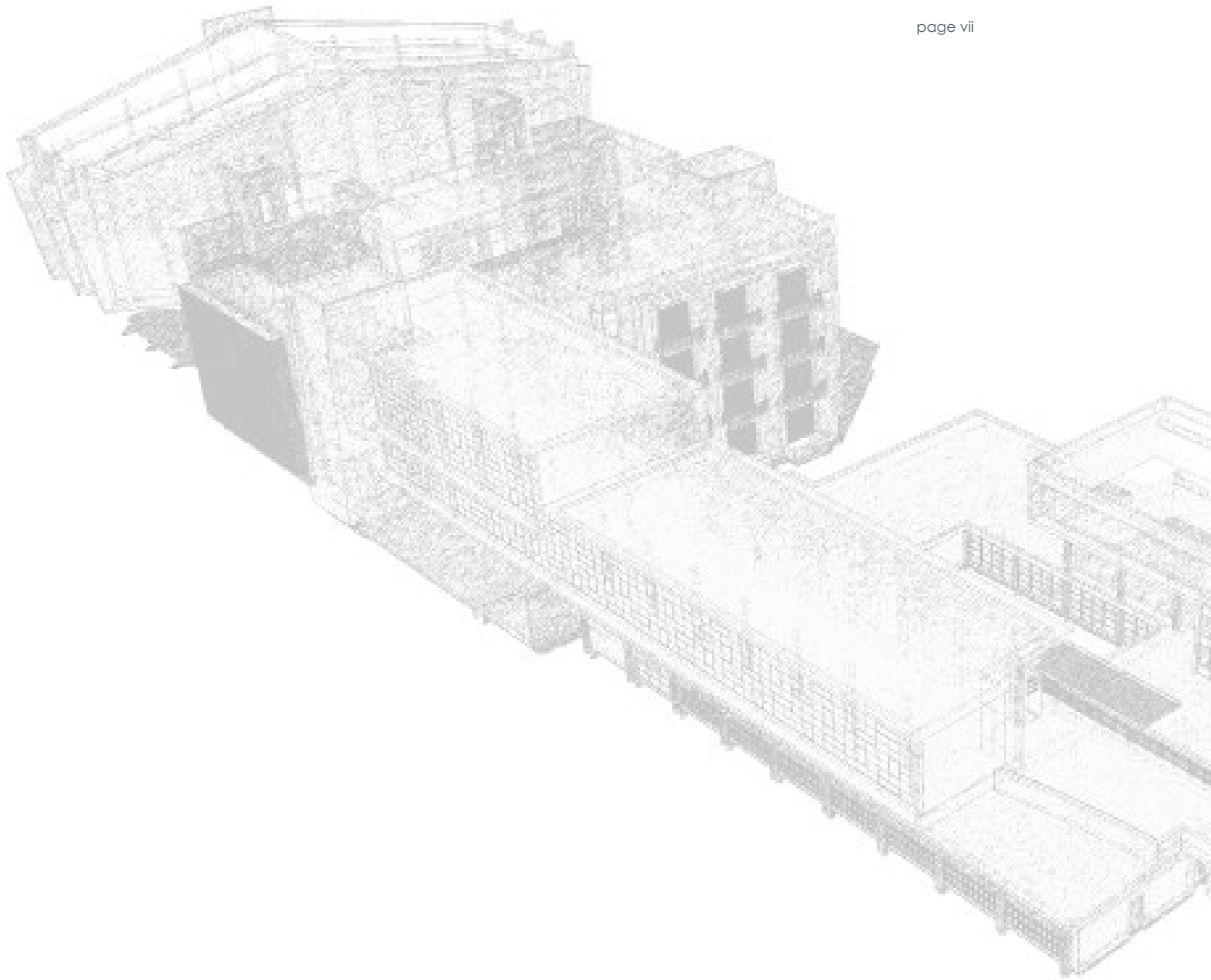

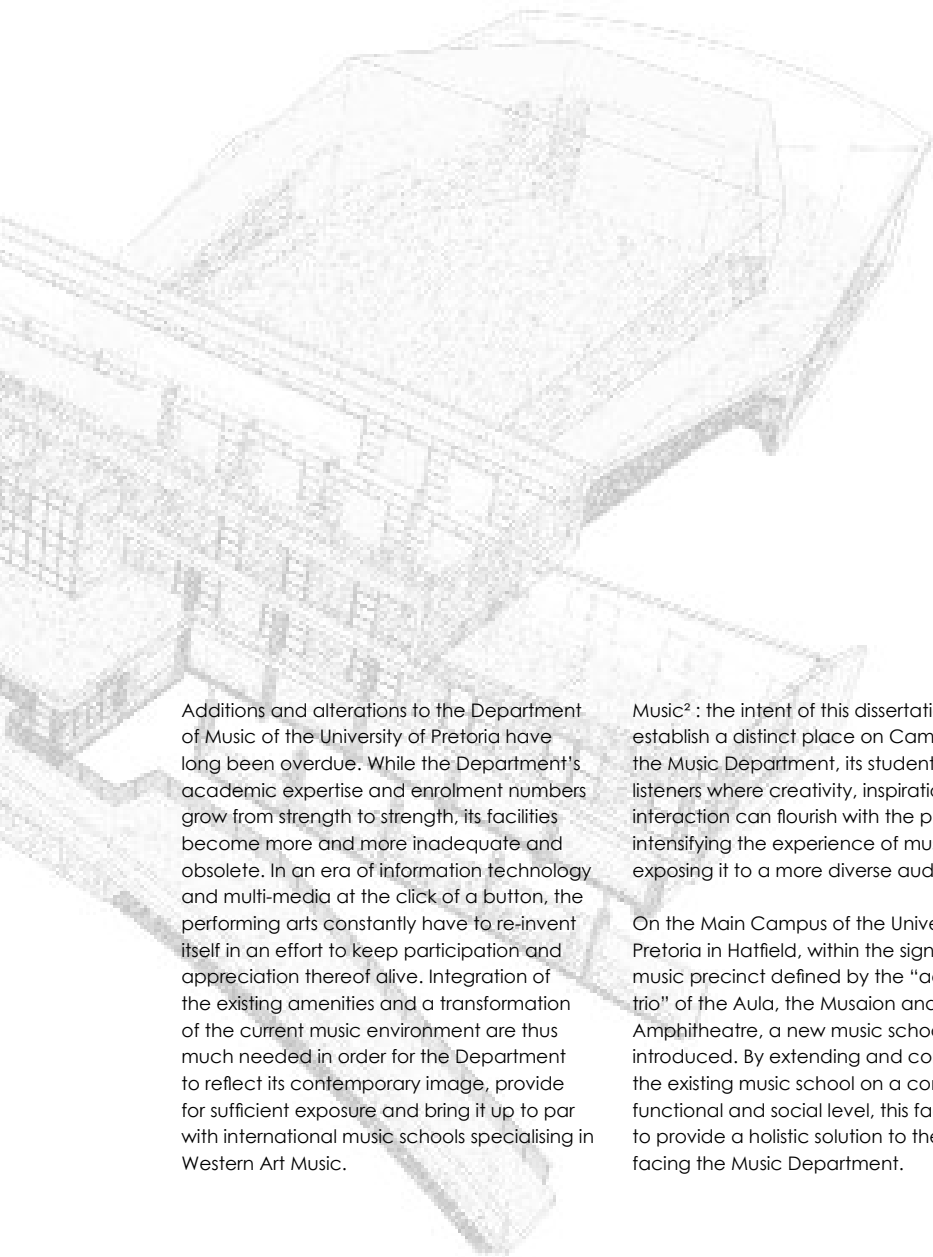

Additions and alterations to the Department of Music of the University of Pretoria have long been overdue. While the Department's academic expertise and enrolment numbers grow from strength to strength, its facilities become more and more inadequate and obsolete. In an era of information technology and multi-media at the click of a button, the performing arts constantly have to re-invent itself in an effort to keep participation and appreciation thereof alive. Integration of the existing amenities and a transformation of the current music environment are thus much needed in order for the Department to reflect its contemporary image, provide for sufficient exposure and bring it up to par with international music schools specialising in Western Art Music.

Music<sup>2</sup>: the intent of this dissertation is to establish a distinct place on Campus for the Music Department, its students and its listeners where creativity, inspiration and interaction can flourish with the purpose of intensifying the experience of music and exposing it to a more diverse audience.

On the Main Campus of the University of Pretoria in Hatfield, within the significant music precinct defined by the "aesthetic trio" of the Aula, the Musaion and the Amphitheatre, a new music school will be introduced. By extending and converting the existing music school on a contextual, functional and social level, this facility aims to provide a holistic solution to the dilemmas facing the Music Department.

# preface

While defining the south west corner of the precinct, the school will also establish contextual links to the public realm and the rest of Campus in an effort to re-energise the area and provide the Music Department with varied coverage. A series of robust and flexible interaction and performance spaces will further aid in the social transformation of the music school environment. An extended and integrated program will concentrate skill and creativity in a legible manner within the precinct to the benefit of students, academics and audiences.

The new music school will be the first of various gradual adaptations envisaged to revitalise the Music Department and the art of music.



# conversion

## contextual

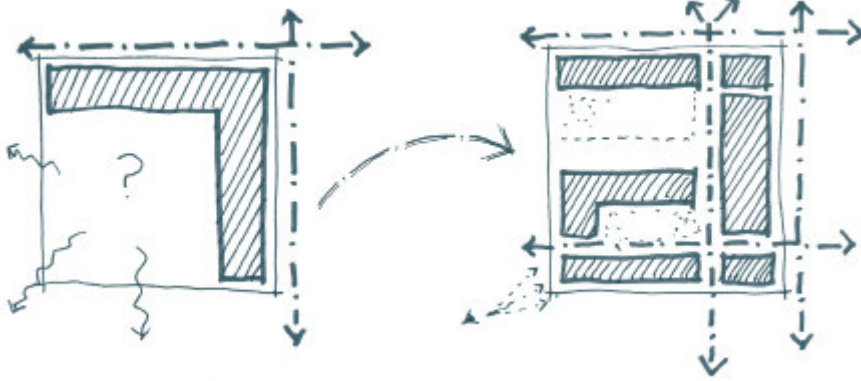

undefined lost spaces  
- integrated responsive places

## functional

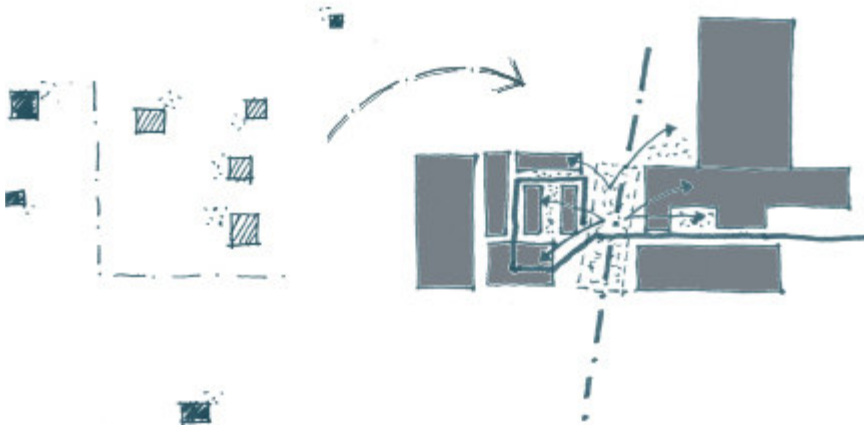

isolated monofunctional venues - integrated cross-programmed spaces

## social

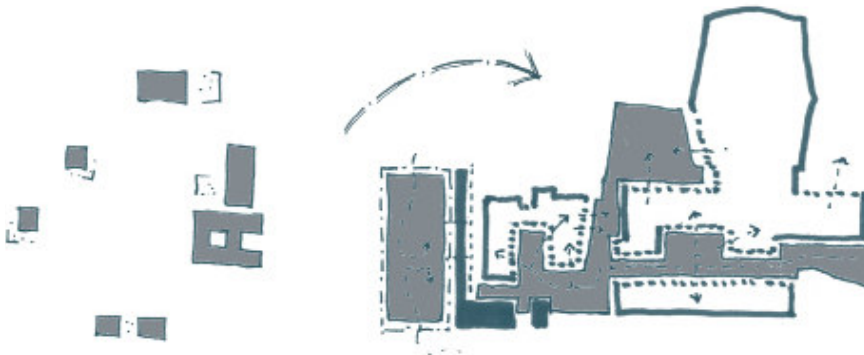

internal programmed & external undefined spaces  
- system of programmed, transition & social spaces





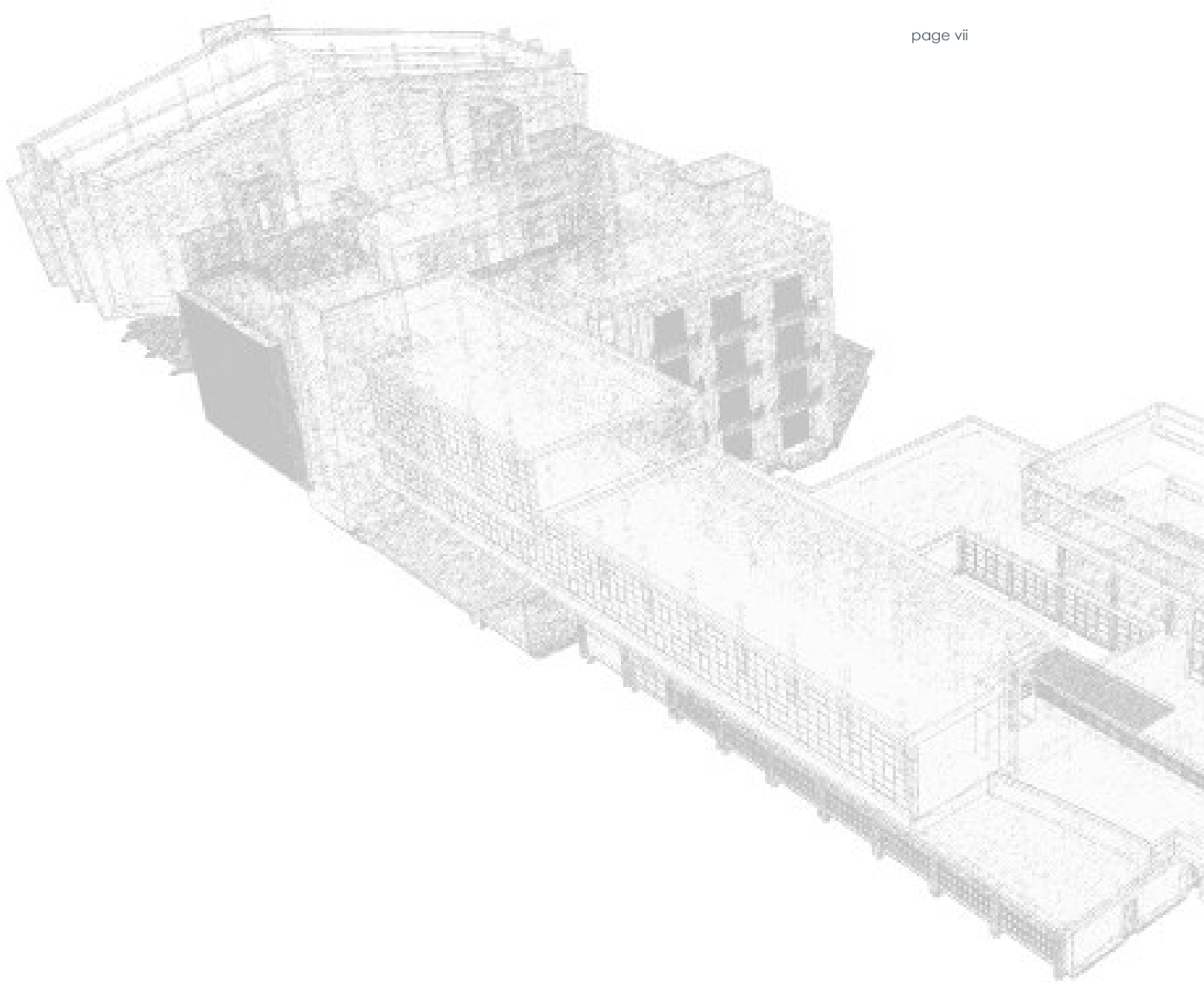

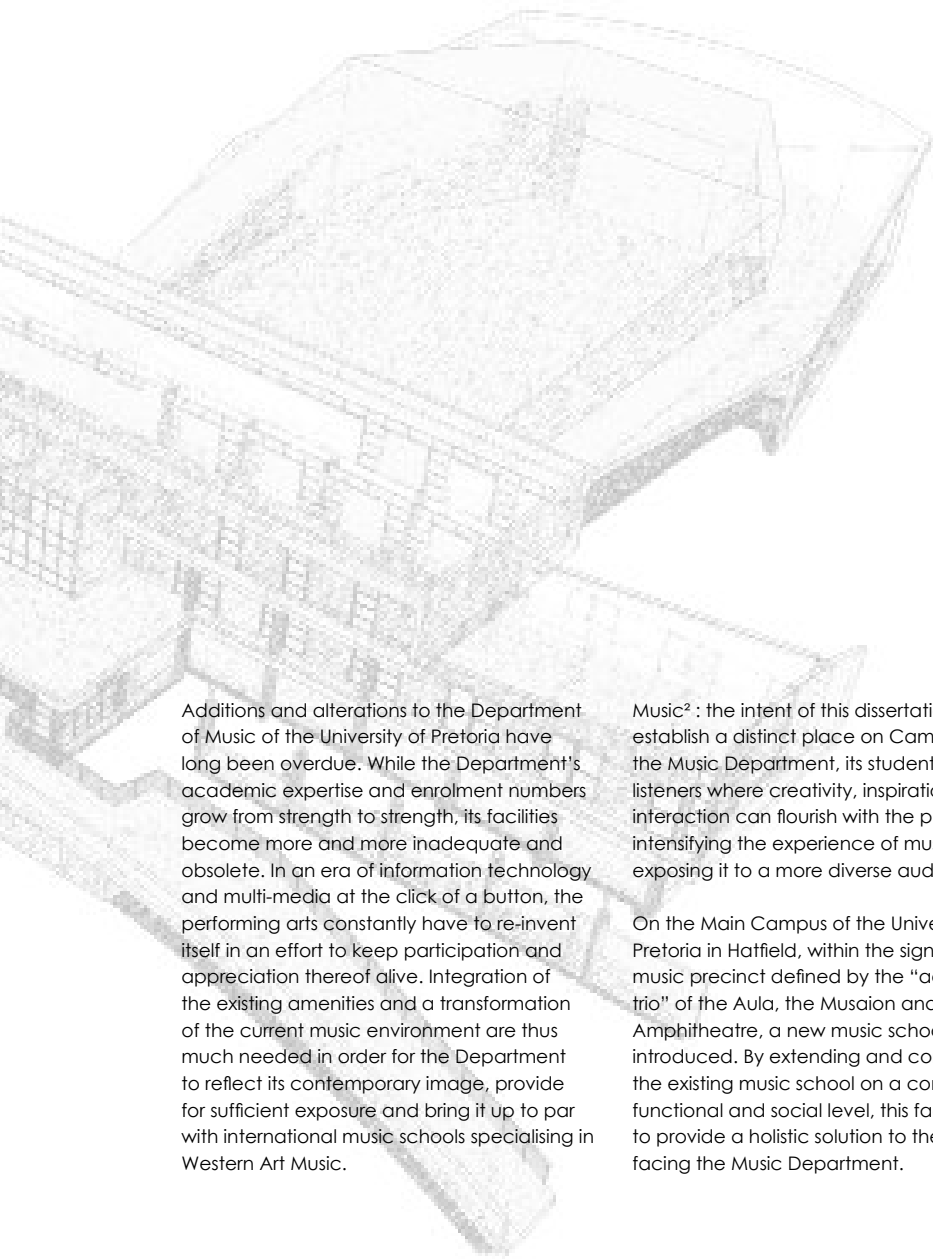

Additions and alterations to the Department of Music of the University of Pretoria have long been overdue. While the Department's academic expertise and enrolment numbers grow from strength to strength, its facilities become more and more inadequate and obsolete. In an era of information technology and multi-media at the click of a button, the performing arts constantly have to re-invent itself in an effort to keep participation and appreciation thereof alive. Integration of the existing amenities and a transformation of the current music environment are thus much needed in order for the Department to reflect its contemporary image, provide for sufficient exposure and bring it up to par with international music schools specialising in Western Art Music.

Music<sup>2</sup> : the intent of this dissertation is to establish a distinct place on Campus for the Music Department, its students and its listeners where creativity, inspiration and interaction can flourish with the purpose of intensifying the experience of music and exposing it to a more diverse audience.

On the Main Campus of the University of Pretoria in Hatfield, within the significant music precinct defined by the "aesthetic trio" of the Aula, the Musaion and the Amphitheatre, a new music school will be introduced. By extending and converting the existing music school on a contextual, functional and social level, this facility aims to provide a holistic solution to the dilemmas facing the Music Department.

## preface

While defining the south west corner of the precinct, the school will also establish contextual links to the public realm and the rest of Campus in an effort to re-energise the area and provide the Music Department with varied coverage. A series of robust and flexible interaction and performance spaces will further aid in the social transformation of the music school environment. An extended and integrated program will concentrate skill and creativity in a legible manner within the precinct to the benefit of students, academics and audiences.

The new music school will be the first of various gradual adaptations envisaged to revitalise the Music Department and the art of music.



## Chapter 1 - The Brief

- 1.1 defining the client
- 1.2 defining the brief
- 1.3 main research questions
- 1.4 assumptions
- 1.5 delimitations
- 1.6 the proposed intervention

p1

## Chapter 2 - The Context

- 2.1 development of the campus
- 2.2 development of the precinct
- 2.3 analysis of the site
- 2.4 analysis of the architectural language
- 2.5 SWOT analysis

p7

## Chapter 3 - The Design Approach

- 3.1 perspectives of the design approach
- 3.2 matrices of the design approach
- 3.3 application of the design approach

p33





**contents**

## Chapter 4 - The Design Influence

- 4.1 brazilian-influenced pretoria regionalism
- 4.2 a new monumentality - monumental modernism
- 4.3 a new modernism - new brutalism

p41

## Chapter 5 - The Precedent Studies

- 5.1 law building
- 5.2 centenary building
- 5.3 carpenter centre

p51



# list of figures

diagrammatic preface: diagrams by author  
preface: 3D render by Author

## Chapter 1 - The Brief

- Fig. 1.1 Graphics of Music Department, Arts and Culture Calendar, UP, 2008
- Fig. 1.2 Aerial Photo – UP Archives, 2008

## Chapter 2 - The Context

- Fig. 2.1 Aerial Photo, UP Department of Geography, Diagram by Author
- Fig. 2.2 Diagrams by Author
- Fig. 2.3-2.10 Photos of Campus, UP Archives, 2008
- Fig. 2.11 Aerial Photo, UP Department of Geography, Diagram by Author
- Fig. 2.12-2.13 Photos from Article in Skakelblad, UP Archives
- Fig. 2.14 Photo, UP Archives
- Fig. 2.15-2.16 Photo, UP Archives
- Fig. 2.17 Photo - Fischer, R.C., 1999
- Fig. 2.18-2.19 Photos, UP Archives
- Fig. 2.20 Sketches by Author
- Fig. 2.21 Aerial Photo, UP Department of Geography, Diagram by Author
- Fig. 2.22-2.32 Photos by Author
- Fig. 2.33-2.35 Aerial Photos, UP Department of Geography, Diagram by Author
- Fig. 2.36 Aerial Photos, UP Archives
- Fig. 2.37-2.45 Photos by Author
- Fig. 2.46 Photos by Author

## Chapter 3 - The Design Approach

- Fig. 3.1 Aerial Photo – Digest of SA Architecture, 2005/2006
- Fig. 3.2 Graphics by Author
- Fig. 3.3 Photo – Alexander, C., 2001:231
- Fig. 3.4 Diagrams by Author

## Chapter 4 - The Design Influence

- Fig. 4.1-4.8 Photos – Jooste, M., 2007:84-88
- Fig. 4.9-4.10 Photos by Author
- Fig. 4.11-4.17 Photo Montage – Internet: Brutalism

## Chapter 5 - The Precedent Studies

- Fig. 5.1 Photo & Artist's Impression by Author
- Fig. 5.2 Drawings – Studio Kruger Roos: Digest of SA Architecture, 2005/2006
- Fig. 5.3-5.5 Photos by Author
- Fig. 5.6-5.12 Photos by Author
- Fig. 5.13-5.19 Photos – Carpenter Centre: [www.essentialarchitecture.com](http://www.essentialarchitecture.com).

## Chapter 6 - The Design Development

- Fig. 6.1 Urban Views by Author
- Fig. 6.2-6.3 Aerial Photo, UP Department of Geography, Diagram by Author
- Fig. 6.4-6.6 Diagrams by Author
- Fig. 6.7 Aerial Photo, UP Department of Geography, Diagram by Author
- Fig. 6.8 Design Sketch by Author
- Fig. 6.9-6.15 Diagrams by Author
- Fig. 6.16-6.21 Sketches by Author
- Fig. 6.22-6.44 3D Views by Author

## Chapter 7 - The Technical Resolution

- Fig. 7.1 3D Views by Author
- Fig. 7.2 Material Collage, Mathews, P.J., 2007
- Fig. 7.3-7.10 3D Views by Author
- Fig. 7.11-7.21 Drawings by Author
- Fig. 7.22 Diagram, Ryker, L., 2007:55
- Fig. 7.23 Drawings by Author
- Fig. 7.24 Diagram by Author
- Fig. 7.25 Details, Adler, D., 1999:19-4

## Chapter 8 - The Drawings

- Fig. 8.1 3D Sketches by Author  
All drawings and 3D views by Author

## Chapter 6 - The Design Development

p59

- 6.1 development of an urban strategy
- 6.2 development of a new centre
  - 6.2.1 design generators - context
  - 6.2.1 design generators - spaces, forms & scale
  - 6.2.3 design generators - function
  - 6.2.4 design generators - circulation
  - 6.2.5 design generators - architecture
- 6.3 views of the building

## Chapter 7 - The Technical Resolution

p81

- 7.1 structural & technological systems
  - 7.1.1 lecture halls
  - 7.1.2 services block
  - 7.1.3 ablution block
  - 7.1.4 practice block
  - 7.1.5 media centre & research lounge
  - 7.1.6 circulation towers
- 7.2 materiality & composition
- 7.3 environmental systems
  - 7.3.1 natural systems
    - 7.3.1.1 sun study & shading devices
    - 7.3.1.2 rainwater harvesting & storm water
  - 7.3.2 artificial systems
    - 7.3.2.1 refuse
    - 7.3.2.2 fire protection
    - 7.3.2.3 drainage
  - 7.3.3 hybrid systems
    - 7.3.3.1 photovoltaic photosynthesis
    - 7.3.3.2 air-conditioning
- 7.4 acoustic requirements

p109

## Chapter 8 - The Drawings

- 8.1 site plan
- 8.2 plans
- 8.3 elevations
- 8.4 sections
- 8.5 presentation

## 9 - References

## 10 - List of Figures





# list of references

## [ BOOKS ]

- Adler, D. 1999. *Metric Handbook*. Oxford: Architectural Press.
- Alexander, C. 2001. *The Nature of Order – Book 1*. New York: Oxford University Press.
- Alexander, C. 2001. *The Nature of Order – Book 2*. New York: Oxford University Press.
- Bergh, J.S., Ferreira, O.J.O., Grobler, J.E.H., Pretorius, F. & Stals, N.A. ed. 1996. *Ad Destinatum III 1983 – 1992*. Pretoria: University of Pretoria Press.
- Bosman, D.B., Hiemstra, L.W. & Van der Merwe, I.W. ed. 1982. *Tweetalige Woordboek, Afrikaans – Engels*. Cape Town: Tafelberg Publishers.
- Broadbent, G. 1990. *Emerging Concepts in Urban Space Design*. New York: Van Nostrand Reinhold Company.
- Burns, C.J. & Kahn, A. 2005. *Site Matters: Design, Histories and Strategies*. New York: Routledge.
- Constantinopoulos, V. ed. 2000. *10 x 10*. New York: Phaidon Press Limited.
- Gehl, J. 1980. *Life Between Buildings – Using Public Space*. New York: Van Nostrand Reinhold Company.
- Gossel, P. & Leuthause, G. ed. 2005. *Architecture in the 20th Century, Volume 1 & 2*. Koln: Taschen.
- Hastings, J. ed. 2005. *10 x 10 \_ 2*. London: Phaidon Press Limited.
- Holm, D. & Viljoen, R. 1996. *Primer for Energy Conscious Design*. Pretoria: Department of Minerals and Energy.
- Mathews, P.J. 2003. *Architecture*. Pretoria: Visual Books.
- Mathews, P.J. 2007. *Detail Housed*. Pretoria: Visual Books.
- Muir, H. & Drake, L. ed. 2005. *The Phaidon Atlas of Contemporary World Architecture – Travel Edition*. London: Phaidon Press Limited.
- Righini, P. 2000. *Thinking Architecturally – An Introduction to the Creation of Form and Place*. Cape Town: University of Cape Town Press.
- Ryker, L. 2007. *Off the Grid Homes – Case Studies for Sustainable Living*. Utah: Gibbs Smith, Publisher.
- Soanes, C. ed. 2002. *South African Pocket Oxford Dictionary*. Cape Town: University Press South Africa (Pty) Ltd.
- Spies, F.J. du T. & Heydenrych, O.H. ed. 1987. *Ad Destinatum II 1960 – 1982*. Cape Town: CTP Publishers.
- Trancik, R. 1986. *Finding Lost Space: Theories of Urban Design*. New York: Van Nostrand Reinhold Company.
- Van der Watt, F. ed. 2002. *Ad Destinatum IV 1993 – 2000*. Pretoria: UP Business Print Centre.
- Whyte, H.W. 1980. *The Social Life of Small Urban Spaces*. Washington D.C.: The Conservation Foundation.
- Quezado Deckker, Z. 2001. *Brazil Built: The Architecture of The Modern Movement in Brazil*. London: Spon Press.

## [ PERIODICALS ]

- Bertolucci, C. 2003. *Frozen Music*. *Architectural Review*. May 2003, vol. 213, issue 1275, p.42-49.
- Fisher, R., Le Roux, H., Murray, N. & Sanders, P. 2003. *The Modern Movement Architecture of Four South African Cities*. *Docomomo*. March 2003, vol. 38, p.68-75.
- Fromm, D. & Elbasani, B. 2003. *Mixed Use College Gateways*. *Urban Land*. October 2003. p.93-95.
- Gehl, J., Kaefer, L.J. & Reigstad, S. 2006. *Close Encounters with Buildings*. *Urban Design International*. April 2006. Vol. 11, nr. 1, p.29-47.
- Robinson, L. 2007. *Twentieth Century Architectural Heritage at Risk*. *Architecture South Africa – Journal of the South African Institute of Architects*. March/April 2007. p.48.
- Slessor, C. 2003. *Urban Orchestration*. *Architectural Review*. May 2003, vol. 213, issue 1275, p.64-69.
- Strohm, P. 2006. *Making Space for Place*. *Urban Land*. August 2006. p.70-73.

## [ ARTICLES ]

- Fisher, R.C. 1999. *The Native Heart: The Architecture of the University of Pretoria Campus*. In *Blank\_ Architecture, Apartheid and After*. Edited by Judin, H. & Vladislavic, I. Rotterdam: NAI Publishers, 2E.
- Gerneke, G. 1998. *From Brazil to Pretoria*. In *Architecture of the Transvaal*. Edited by Fisher, R.C., Le Roux, S. & Maré, E. Pretoria: Unisa



## [ NOTES ]

- Barker, A. 2004. Post-Modernism. Cape Town: Cape Technikon. [Unpublished Course Notes].
- De La Port, JP. 2007. Post-Modernism Theories. Pretoria: University of Pretoria. [Unpublished Course Notes].

## [ ACADEMIC DISSERTATIONS ]

- Do Vale, B.A. 2007. Cognition – Composing a South African Identity. MArch (Prof) thesis. University of Pretoria.
- Ellmore, A.J. 2005. Path – A Passenger Cruise Terminal for Durban. MArch (Prof) thesis. University of Pretoria.
- Jooste, M. 2007. Can You See the Music? MTV Base Television Production Centre. MArch (Prof) thesis. University of Pretoria.
- Malan, S.F. 2008. Social Classroom. Symbol of Function Beyond Programme. MArch (Prof) thesis. University of Pretoria.

## [ REPORTS ]

- The Australian ICOMOS Charter. (1979: Burra). 1999. The Burra Charter for the Conservation of Places of Cultural Significance. Australian ICOMOS members. Burra: Australia ICOMOS.
- Y & K Architects Project Proposal. (2008: Pretoria). 2008. Aanbouings aan UP Musiekbiblioteek en Musiekdepartement. Edited by Thomashof, K. Pretoria: Y & K Architects.

## [ INTERVIEWS ]

- Hinch, J. de C. Interviewed on 13 February 2008
- Potgieter, D. Interviewed on 4 February 2008.

## [ WEBSITES ]

- <http://www.academic.sun.ac.za/music/programmes.html> Department of Music and Konservatorium. (4 Mar. 2008).
- <http://www.academic.sun.ac.za/music/facilities.html> (4 Mar. 2008).
- <http://www.arts.USCS.edu/musiccentre/prelock.html> The UCSC Music Centre – Architect Statement. (4 Mar. 2008).
- <http://www.artsci.wustl.edu/music/facilities.html> (4 Mar. 2008).
- <http://www.finearts.uvic.ca/music/facilities/> (4 Mar. 2008).
- <http://www.lib.berkeley.edu/MUSI/update.html> UC Berkeley Music Library, Facilities and Access, Construction Update – Jean Gray Hargrove Music Library. (4 Mar. 2008).
- <http://www.music.berkeley.edu/friends.html> Facilities Expansion and Development, Department of Music, University of California, Berkeley (4 Mar. 2008).
- <http://www.music.wisc.edu/about/facilities> UW School of Music: Facilities and Resources. (4 Mar. 2008).
- <http://web.uct.ac.za/depts/sacm/kirby.html> SACM: The Kirby Collection. (4 Mar. 2008).
- <http://web.uct.ac.za/depts/sacm/organ.html> SACM: The Von Beckerath Organ. (4 Mar. 2008).
- <http://www.up.ac.za/deps/humanities/music.html> (4 Mar. 2008).
- <http://en.wikipedia.org/wiki/Music> Music – Wikipedia, the free encyclopedia. (4 Mar. 2008).
- <http://en.wikipedia.org/wiki/Silence> Silence – Wikipedia, the free encyclopedia. (4 Mar. 2008).
- <http://www.metropolismag.com> The Last of The Modernists. (18 Jul. 2009).
- <http://www.bookrags.com> Brutalist Architecture Summary. (24 Jul. 2009).
- <http://www.excitingbrazil.com> (24 Jul. 2009).
- <http://www.essentialarchitecture.com> The Carpenter Centre. (3 Aug. 2009).
- <http://www.helium.com> Understanding Brutalist Architecture. (3 Aug. 2009).





acknowledgements

---



UNIVERSITEIT VAN PRETORIA  
UNIVERSITY OF PRETORIA  
YUNIBESITHI YA PRETORIA

to pieter, my parents and my friends

you supported and encouraged me every step of the way

---