

Fract[ure]al Platform Building at Menlyn

by Jané Pretorius

Submitted in partial fulfilment of the requirements for the degree
Master of Architecture (Professional)
Department of Architecture
Faculty of Engineering, Built Environment and Information Technology
University of Pretoria

Study Leader & Course Coordinator: Jacques Laubscher (Dr)

Pretoria

2011

Full dissertation title:	Fract[ure]al: Platform Building at Menlyn
Submitted by:	Jané Pretorius
Student number:	26049423
Study leader & course coordinator:	Jacques Laubscher (Dr)
Degree:	Master of Architecture (Professional)
Department:	Department of Architecture
Faculty:	Faculty of Engineering, Built Environment and Information Technology
University:	University of Pretoria

PROJECT SUMMARY

Programme:

Platform building for Gautrain station at Menlyn

Site description:

Menlyn Intermodal Transport Exchange

Client:

Gautrain Rapid Rail Link

Users:

Users of the Gautrain and the Menlyn Intermodal Transport Exchange, staff of the Menlyn Intermodal Transport Exchange and the general public

Site Location:

Erf 69, Menlyn

Address:

Corner of Frikkie de Beer Street and Dallas Road, Menlyn, Tshwane, South Africa

GPS Coordinates:

25°78'49.57"S, 28°28'06.35"E

Architectural Theoretical Premise:

Chaos theory, fractals and small-world networks

Architectural Approach:

Emphasize Menlyn as a node in Tshwane and integrate the various transport systems present in the Menlyn precinct.

Research Field:

Urbanism and human settlements



ILLUS. 1.1: Queen Anne's Lace plant as an example of fractals within nature.

FRACTAL

Noun

- A curve or geometrical figure, each part of which has the same statistical character as the whole. **THEY ARE USEFUL IN MODELLING STRUCTURES IN WHICH SIMILAR PATTERNS RECUR AT PROGRESSIVELY SMALLER SCALES**, and in describing partly random or chaotic phenomena such as crystal growth and galaxy formation.

Adjective

- Relating to or, of the nature of a fractal, or fractals: fractal geometry.

~ Oxford Dictionaries, 2011.



ILLUS. 1.2: X-Ray of a fractured arm.

FRACTURE

Noun

- The cracking or breaking of a hard object or material.
- A crack or break in a hard object or material, typically a bone or a rock stratum.
- The physical appearance of a freshly broken rock or mineral, especially as regards the shape of the surface formed.

Verb

- Break or cause to break.
- Sustain a fracture.
- Split or fragment within an organisation and become unable to function or exist
- **FALTERING AND FULL OF MISTAKES; BROKEN.**

~ Oxford Dictionaries, 2011.

Met dank aan my Skepper.

Dankie aan
my ouers, Herman en familie,
CJ en sy familie,
my vriende,
Jacques en Michelle se ma wat my ondersteun en in my glo.

In accordance with Regulation 4(e) of the General Regulations (G.57) for dissertations and theses, I declare that this dissertation, which I hereby submit for the degree Master of Architecture (Professional) at the University of Pretoria, is my own work and has not previously been submitted by me for a degree at this or any other tertiary institution.

I further state that no part of my dissertation has already been, or is currently being, submitted for any such degree, diploma or other qualification.

I further declare that this dissertation is substantially my own work. Where reference is made to the works of others, the extent to which that work has been used is indicated and fully acknowledged in the text and list of references.

The dissertation is 15 800 words long (excluding the scanned items).

Jané Pretorius

TABLE OF CONTENTS

PROJECT SUMMARY	iii	2.2.2 DESIGN INTENT	23	5.2.2 MENLYN NODE URBAN DEVELOPMENT FRAMEWORK (MNUDF)	46
FRACTAL	v	2.2.3 AIMS AND OBJECTIVES OF THE REMAINDER OF THE STUDY	23	5.2.3 MENLYN NODE SPATIAL DEVELOPMENT FRAMEWORK (MNSDF)	46
FRACTURE	v				
TABLE OF CONTENTS	viii				
LIST OF ILLUSTRATIONS	x	CHAPTER 3 - THEORETICAL ARGUMENT	24	5.3 PROPOSED TRANSPORT FRAMEWORK	48
LIST OF TABLES	xv	3.1 COMPLEX SYSTEMS	24	5.4 DESIGN PRINCIPLES APPLIED TO NEW MENLYN NODE FRAMEWORK	50
		3.2 CHAOS THEORY	25	5.5 NEW MENLYN NODE FRAMEWORK	52
CHAPTER 1 - INTRODUCTION	1	3.3 FRACTALS	26		
1. INTRODUCTION	1	3.4 SMALL-WORLD NETWORKS	28	CHAPTER 6 - DESIGN DEVELOPMENT	56
1.1 PROBLEM STATEMENT	2	3.5 CONCLUSION	28	6.1 APRIL - FINAL PROJECT PROPOSAL AND CONCEPT	57
1.2 BRIDGING THE FRACT[URE]	2			6.2 MAY - CONCEPT DEVELOPMENT	58
1.3.HYPOTHESIS	4	CHAPTER 4 - CASE STUDIES & PRECEDENTS	30	6.3 JUNE - DESIGN (SKETCH PLAN STAGE)	59
1.4 LITERATURE	4	4.1 GAUTRAIN SANDTON STATION	32	6.4 JULY - DESIGN (ADVANCED SKETCH PLAN STAGE)	60
1.5 METHODOLOGY	6	4.2 SANDTON CONVENTION CENTRE	34	6.5 AUGUST - TECHNICAL 1	61
1.5.1 RESEARCH METHODOLOGY	6	4.3 PALAIS DE JUSTICE	36	6.6 SEPTEMBER - TECHNICAL 2	62
1.5.2 DELIMITATIONS	6			6.7 DISCOVERIES AND NEW PERSPECTIVES	63
		CHAPTER 5 - URBAN FRAMEWORK	38		
CHAPTER 2 - REVIEW & REASONING	8	5.1 MENLYN NODE ANALYSIS	38	CHAPTER 7 - DESIGN SOLUTION	64
2.1 BACKGROUND	8	5.1.1 CURRENT LAND USE	39	7.1 ACCOMMODATION LIST	66
2.1.1 CONTEXT	10	5.1.2 GREEN STRUCTURE	39	7.1.1 GROUND FLOOR (PUBLIC)	66
2.1.2 THE INFLUENCE OF THE MOTOR VEHICLE ON CITY LAYOUT	12	5.1.4 VEHICULAR MOVEMENT	41	7.1.2 FIRST FLOOR (SEMI-PUBLIC/PRIVATE)	66
2.1.3 ESTABLISHMENT OF MENLYN AS A NODE	12	5.1.3 SWOT ANALYSIS	41	7.1.3 SECOND FLOOR (PRIVATE)	67
2.1.4 MODES OF TRANSPORT	14	5.2 EXISTING FRAMEWORKS	44	7.2 FINAL DESIGN	68
2.2 MOTIVATION	22	5.2.1 TSHWANE REGIONAL SPATIAL DEVELOPMENT FRAMEWORK: EASTERN REGION (TRSDF)	44		
2.2.1 TRANSIT ORIENTED DEVELOPMENT	23				

CHAPTER 8 - TECHNICAL RESOLUTION	72
8.1 MATERIALS	72
8.1.1 CONCRETE	72
8.1.2 SEMI-TRANSPARENT PHOTOVOLTAIC GLASS	74
8.1.3 METAL FABRIC	75
8.2 STRUCTURAL SYSTEM	76
8.3 METAL FABRIC BOX-LIKE STRUCTURE	78
8.4 CIRCULATION	81
8.5 VENTILATION	82
8.6 DRAINAGE & SOLAR ENERGY	83
8.7 ELEVATIONS	84
8.8 SITE PLAN	85
8.9 GROUND FLOOR PLAN	86
8.10 FIRST FLOOR PLAN	88
8.11 SECOND FLOOR PLAN	90
8.12 ROOF PLAN & DETAIL	92
8.13 OTHER	95
8.14 SECTION AA	96
8.15 LESSONS I LEARNED AS AN ARCHITECTURE STUDENT	98
REFERENCES	99
APPENDIX A	102
APPENDIX B	108
APPENDIX C	112
APPENDIX D	114

LIST OF ILLUSTRATIONS

ILLUS. 1.1: Queen Anne's Lace plant as an example of fractals within nature. www.google.images.com . Edited by author, 2011.	v
ILLUS. 1.2: X-Ray of a fractured arm. www.learningradiology.com . Edited by author, 2011.	v
ILLUS. 1.3: Taxis on sidewalk of Atterbury Road. Author, 2011.	2
ILLUS. 1.4: Pedestrians jaywalking on Atterbury Road. Author, 2011.	2
ILLUS. 1.5: Bus shelter on Atterbury Road. Author, 2011.	2
ILLUS. 1.6: Road network of Menlyn area contributes to a fractured experience of the area. Author, 2011.	3
ILLUS. 1.7; Entrance to Union Station at Los Angeles' Gateway Center. www.google.earth.com . Edited by author, 2011.	4
ILLUS. 1.8: Aerial photograph of Gateway Center. www.google.earth.com . Edited by author, 2011.	4
ILLUS. 1.9: Bus Stop at Dundee Central Bus Exchange. www.nsarchitects.com/BCPT.html . Edited by author, 2011.	4
ILLUS. 1.10: Aerial photograph of Dundee Central Bus Exchange. www.google.earth.com . Edited by author, 2011.	4
ILLUS. 1.11: Hoenheim-Nord Station. www.archnewsnow.com . Edited by author, 2011.	
ILLUS. 1.12: Aerial photograph of Hoenheim-Nord Station. www.google.earth.com . Edited by author, 2011.	
ILLUS. 1.13: Context plan. Author, 2011.	6
ILLUS. 2.1: Greater context indicating urban nodes, stations and surrounding suburbs. Author, 2011.	8
ILLUS. 2.2: Location of proposed site. Author, 2011.	10
ILLUS. 2.3: Plan of Menlyn precinct indicating walking radii from site, existing transport and the location of the future Menlyn Gautrain Station. Author, 2011.	10
ILLUS. 2.4: Comparison of existing street layouts for Pretoria CBD (grid) and Menlyn precinct (free flowing). Author, 2011.	12
ILLUS. 2.5: Route to pedestrian stairway. Author, 2011.	14
ILLUS. 2.6: Sidewalk obstructed by infrastructure. Author, 2011.	14
ILLUS. 2.7: Pedestrian path through parking garage. Author, 2011.	15
ILLUS. 2.8: Bus shelter located on sidewalk. Author, 2011.	15
ILLUS. 2.9: Three-lane road with jaywalker. Author, 2011.	15
ILLUS. 2.10: Aerial map of route. Author, 2011.	15
ILLUS. 2.11: Hierarchal layout of roads in Menlyn; Existing informal taxi ranks and formal pedestrian crossings. Author, 2011.	16

ILLUS. 2.12: History of mini-bus taxi industry. Author, 2011.	18
ILLUS. 2.13: Lois Avenue taxi stop. Author, 2011.	18
ILLUS. 2.14: Atterbury Road taxi stop. Author, 2011.	18
ILLUS. 2.15: Plan of existing bus routes at Menlyn precinct. Author, 2011.	19
ILLUS. 2.16: BRT Route Line 2. Author, 2011.	20
ILLUS. 2.17: Plan of underground Gautrain route at Menlyn precinct. Author, 2011.	21
ILLUS. 3.1: Current Menlyn precinct transport system as complex system. Author, 2011.	24
ILLUS. 3.2: Current Menlyn precinct transport system as chaotic system. Author, 2011.	25
ILLUS. 3.3: Self-similarity of road connections across different scales. Important road networks of Africa, South Africa, Gauteng and Tshwane respectively. Author, 2011.	26
ILLUS. 3.4: Collage of images indicating self-similarities in Menlyn precinct. Author, 2011.	26
ILLUS. 3.5: Palais de Justice, Nantes (2000), by Jean Nouvel. Progression of interest at different scales. Author, 2010.	27
ILLUS. 3.6: Small-world network principles applied to design proposal. Author, 2011.	29
ILLUS. 3.7: Principle of small-world networks applied to Tshwane. Author, 2011.	29
ILLUS. 4.1: Signage outside the Gautrain Sandton Station. Author, 2011.	31
ILLUS. 4.2: Exterior of the Sandton Convention Centre. www.saconvention.co.za/SandtonConventionCentre_Venue.asp . Edited by author, 2011.	31
ILLUS. 4.3: Interior of the Palais de Justice. Author, 2010.	31
ILLUS. 4.4: Design application of Gautrain Sandton Station to the Platform Building at Menlyn. Author, 2011.	32
ILLUS. 4.5: Photo collage of Gautrain Sandton Station. Author, 2011.	33
ILLUS. 4.6: Design application of Sandton Convention Centre to the Platform Building at Menlyn. Author, 2011.	35
ILLUS. 4.7: Photo collage of Sandton Convention Centre including diagrammatic section. Author, 2011.	35
ILLUS. 4.8: Design application of Palais de Justice to the Platform Building at Menlyn. Author, 2011.	36
ILLUS. 4.9: Photo collage of Palais de Justice, including ground floor plan. Author, 2011.	37
ILLUS. 5.1: Current land use of Menlyn node. Author and Fransa van Zyl, 2011.	38
ILLUS. 5.2: Menlyn square as example of commercial use. Author, 2011.	39
ILLUS. 5.3: Old Mutual Office Park as example of business use. Author, 2011.	39
ILLUS. 5.4: Damelin College as example of educational use. Author, 2011.	39

ILLUS. 5.5: Litter in Menlyn node. Author, 2011.	39
ILLUS. 5.6: Green structure of Menlyn node. Author and Fransa van Zyl, 2011.	39
ILLUS. 5.7: Vehicular movement in Menlyn node. Author and Fransa van Zyl, 2011.	40
ILLUS. 5.8: Traffic congestion on Atterbury Road. Author, 2011.	41
ILLUS. 5.9: Development in Menlyn node - 2010. Author, 2011.	41
ILLUS. 5.10: Development in Menlyn node - 2020. Author, 2011.	41
ILLUS. 5.11: Visual context of precinct. Author and Fransa van Zyl, 2011.	42
ILLUS. 5.12: Tsošološo programme principles applied to NEW MENLYN NODE FRAMEWORK. Author and Fransa van Zyl, 2011.	45
ILLUS. 5.13: Menlyn Node Urban Development Framework. Author and Fransa van Zyl, 2011.	47
ILLUS. 5.14: Proposed underground Gautrain route. Author, 2011.	48
ILLUS. 5.15: Proposed bus routes. Author, 2011.	48
ILLUS. 5.16: Proposed taxi routes. Author, 2011.	49
ILLUS. 5.17: Proposed motor vehicular routes. Author, 2011.	49
ILLUS. 5.18: Proposed pedestrian routes. Author, 2011.	49
ILLUS. 5.19: Plan and section of a typical pedestrian boulevard. Author and Fransa van Zyl, 2011.	50
ILLUS. 5.20: Plan and section of a typical mall passage. Author and Fransa van Zyl, 2011.	50
ILLUS. 5.21: Comparison of mall and framework layout. Fransa van Zyl, 2011.	51
ILLUS. 5.22: Plan and section of event space. Author and Fransa van Zyl, 2011.	51
ILLUS. 5.23: Plan and section of public square as event space. Author and Fransa van Zyl, 2011.	51
ILLUS. 5.24: Pedestrian crossing Genl. Louis Botha Drive. Author and Fransa van Zyl, 2011.	52
ILLUS. 5.25: Pedestrian bridge at Lois Avenue. Author and Fransa van Zyl, 2011.	52
ILLUS. 5.26: Section of Dallas Road. Author and Fransa van Zyl, 2011.	52
ILLUS. 5.27: Section of Frikkie de Beer Street and Amarand Road. Author and Fransa van Zyl, 2011.	52
ILLUS. 5.28: NEW MENLYN NODE FRAMEWORK. Author and Fransa van Zyl, 2011.	53
ILLUS. 5.29: Proposed precinct development heights. Author, 2011.	54
ILLUS. 5.30: Precinct plan. Author and Fransa van Zyl, 2011.	54
ILLUS. 6.1: Menlyn Intermodal Transport Exchange planning diagrams - April. Author, 2011.	57
ILLUS. 6.2: Menlyn Intermodal Transport Exchange site plan diagrams - May. Author, 2011.	58
ILLUS. 6.3: Platform Building at Menlyn sketch plans and drawings - June. Author, 2011.	59

ILLUS. 6.4: Platform Building at Menlyn sketches, plans and drawings - July. Author, 2011.	60
ILLUS. 6.5: Platform Building at Menlyn sketch section - August. Author, 2011.	61
ILLUS. 6.6: Platform Building at Menlyn diagram, ground floor plan and first floor plan - September. Author, 2011.	62
ILLUS. 6.7: Platform Building at Menlyn section - October. Author, 2011.	63
ILLUS. 7.1: Functions indicated per level. Author, 2011.	64
ILLUS. 7.2: Sketch of Platform Building at Menlyn from South West corner. Author, 2011.	65
ILLUS. 7.3: Location of platform building on site and in relation to other transport modes. Author, 2011.	65
ILLUS. 7.4: Location of facilities in the Platform Building at Menlyn. Author, 2011.	67
ILLUS. 7.5: Parti diagram. Author, 2011.	68
ILLUS. 7.6: Platform and column-and-beam structure. Author, 2011.	68
ILLUS. 7.7: Objects on platform. Author, 2011.	68
ILLUS. 7.8: Perspective of Platform Building at Menlyn from South East corner. Author, 2011.	68
ILLUS. 7.9: Example of stereotomic vs. tectonic on second floor. Author, 2011.	69
ILLUS. 7.10: GKD metal fabric structure. Author, 2011.	69
ILLUS. 7.11: Example of grid pattern. Author, 2011.	69
ILLUS. 7.12: Ground floor plan indicating different functional areas. Author, 2011.	70
ILLUS. 7.13: South elevation of Platform Building at Menlyn. Author, 2011.	71
ILLUS. 7.14: Perspective of Platform Building at Menlyn from North West corner. Author, 2011.	71
ILLUS. 8.1: Illustration of use of concrete in design. www.lafarge.co.za and author, 2011.	72
ILLUS. 8.2: Interior view of installed semi-transparent photovoltaic glazing, location unknown. www.neutraexistence.com/blog/see-through-photovoltaic-glass/ . Edited by author, 2011.	75
ILLUS. 8.3: Construction of semi-transparent photovoltaic glazing. Author, 2008.	75
ILLUS. 8.4: Omega 1520 GKD metal fabric. www.gkdmetalfabrics.com . Edited by author, 2011	75
ILLUS. 8.5: Union theological seminary, Richmond, Virginia. www.gkdmetalfabrics.com . Edited by author, 2011.	75
ILLUS. 8.6: Doral Park, Doral, Florida. www.gkdmetalfabrics.com . Edited by author, 2011.	75
ILLUS. 8.7: Woven-in bar with spring GKD metal fabric attachment method. www.gkdmetalfabrics.com . Edited by author, 2011.	75
ILLUS. 8.8: Perspective of the structural system of the Platform Building at Menlyn. Author, 2011.	76
ILLUS. 8.9: Exploded axonometric of the structural system of the Platform Building at Menlyn. Author, 2011.	76

ILLUS. 8.10: Perspective of the metal fabric box-like structure of the Platform Building at Menlyn. Author, 2011.	78
ILLUS. 8.11: Graphic portrayal of the grid used for the metal fabric box-like structure. Author, 2011.	78
ILLUS. 8.12: Detail of metal fabric box-like structure. Author, 2011.	80
ILLUS. 8.13: Circulation routes. Author, 2011.	81
ILLUS. 8.14: Natural ventilation system. Author, 2011.	82
ILLUS. 8.15: Rainwater collection and solar energy systems. Author, 2011.	83
ILLUS. 8.16: North elevation. Author, 2011.	84
ILLUS. 8.17: South elevation. Author, 2011.	84
ILLUS. 8.18: East elevation. Author, 2011.	84
ILLUS. 8.19: West elevation. Author, 2011.	84
ILLUS. 8.20: Site plan. Author, 2011.	85
ILLUS. 8.21: Ground floor plan. Author, 2011.	86
ILLUS. 8.22: First floor plan. Author, 2011.	88
ILLUS. 8.23: Second floor plan. Author, 2011.	90
ILLUS. 8.24: Roof plan. Author, 2011.	92
ILLUS. 8.25: Glass canopy at California Academy of Sciences (2008) by Renzo Piano. www.architecture-buildings.com . Edited by author, 2011.	93
ILLUS. 8.26: Glass roof structure perspective. Author, 2011.	93
ILLUS. 8.27: Roof detail 1. Author, 2011.	93
ILLUS. 8.28: Roof detail 2. Author, 2011.	94
ILLUS. 8.29: Stair detail. Author, 2011.	95
ILLUS. 8.30: Balustrade detail. www.dorma.co.za , Edited by author, 2011.	95
ILLUS. 8.31: Perspective of section AA. Author, 2011.	96
ILLUS. 8.32: Section AA. Author, 2011.	97
ILLUS. A.1: Entrance to Bloed Street Mall & Taxi Rank. Author, 2011.	102
ILLUS. A.2: Metro Mall Transport Facility. www.urbansolutions.co.za/images/public/metro.html . Edited by author, 2011.	103
ILLUS. A.3: Philippi Public Transport Interchange. Jacqui Perrin. Edited by author, 2011.	103
ILLUS. A.4: Skinner Street Taxi Rank. Author, 2011.	103
ILLUS. A.5: Bloed Street Mall and Taxi Rank lower ground floor sketch plan and circulation plan. Author, 2011.	104
ILLUS. A.6: Metro Mall Transport Facility and Traders Market ground floor sketch plan and circulation plan. Author, 2011.	105

ILLUS. A.7: Philippi Public Transport Interchange site sketch plan and circulation plan. Author, 2011.	105
ILLUS. A.8: Skinner Street Taxi Rank site sketch plan and circulation plan. Author, 2011.	105
ILLUS. A.9: Facilities and section of interface at Bloed Street Mall and Taxi Rank. Author, 2011.	106
ILLUS. A.10: Facilities and section of interface at Metro Mall Transport Facility and Traders Market. Author, 2011.	107
ILLUS. A.11: Facilities and section of interface at Philippi Public Transport Interchange. Author, 2011.	107
ILLUS. A.12: Facilities and section of interface at Skinner Street Taxi Rank. Author, 2011.	107
ILLUS. B.1: Illustration of structural column. Orton (1987: 30-54).	108
ILLUS. B.2: Illustration of reinforced two-way slab. Orton (1987: 30-54).	108
ILLUS. B.3: Illustration of reinforced one-way solid slab. Orton (1987: 30-54).	109
ILLUS. B.4: Illustration of steel column. Orton (1987: 30-54).	109
ILLUS. B.5: Illustration of steel roof. Orton (1987: 30-54).	109
ILLUS. B.6: 2 500l Horizontal Jojo water storage tank. www.jojotanks.co.za. Edited by author, 2011.	111
ILLUS. C.1: Erythrina Lysistemon. www.frangipanieurop.com. Edited by author, 2011.	112
ILLUS. C.2: Harpephyllum Caffrum. www.wildcard.co.za. Edited by author, 2011.	112
ILLUS. C.3: Syzygium Cordatum. www.wildcard.co.za. Edited by author, 2011.	113
ILLUS. C.4: Euclea Crispa subsp. www.plantdiversityofsaudi Arabia.info. Edited by author, 2011.	113
ILLUS. C.5: Heteropyxis Natalensis. www.inheemseboome.co.za. Edited by author, 2011.	113
ILLUS. D.1: Results of SBAT applied to Platform Building. Author, 2011.	115
ILLUS. D.2: View from North East corner. Author, 2011.	116
ILLUS. D.3: Southern side of model. Author, 2011.	117
ILLUS. D.4: Approach from South. Author, 2011.	117
ILLUS. D.5: Aerial view of model. Author, 2011.	117

LIST OF TABLES

TABLE 2.1: Comparison of city block sizes, accessibility and users. (Author, 2011)	12
TABLE 2.2: Hierarchy of roads (Conversation with Pretorius, C., 2011.)	17
TABLE 2.3: Travel times to work (National Household Survey, 2007: 30).	20
TABLE B.1: Sanitary requirements.	110
TABLE B.2: Water storage tank calculations.	111

“The first qualification for judging any piece of workmanship from a corkscrew to a cathedral is to know *what* it is - what it was intended to do and how it was meant to be used. After that has been discovered the temperance reformer may decide that the corkscrew was made for a bad purpose, and the communist may think the same about the cathedral. But such questions come later. The first thing is to understand the object before you: as long as you think the corkscrew was meant for opening tins or the cathedral for entertaining tourists you can say nothing to purpose about them” (Lewis, 1942: 1).

CHAPTER 1

INTRODUCTION

1. INTRODUCTION

In the metropolitan area of Tshwane commuters and inhabitants rely on, and make use of, formal and informal public transport. Motor vehicles are used by approximately 30% of Tshwane's population while the remainder of the population make use of public transport (Department of Transport, 2007: 22).

With such a high percentage of the population making use of public transport, Tshwane's urban infrastructure should accommodate and encourage the use of public transport. However, a lack of public transportation and pedestrian facilities is apparent (City Planning Committee, 2002: [10]).

The National Land Transport Transition Act of 2000 (Government Gazette, 2000: 20) directs

government to actively promote public transport. The Gautrain Rapid Rail Link is an integrated government project that aims at promoting public transport and contributing to a province that is more conducive to public transport and the transfer from one public transport mode to the other (Gautrain, 2011c).



ILLUS. 1.3: Taxis on sidewalk of Atterbury Road.

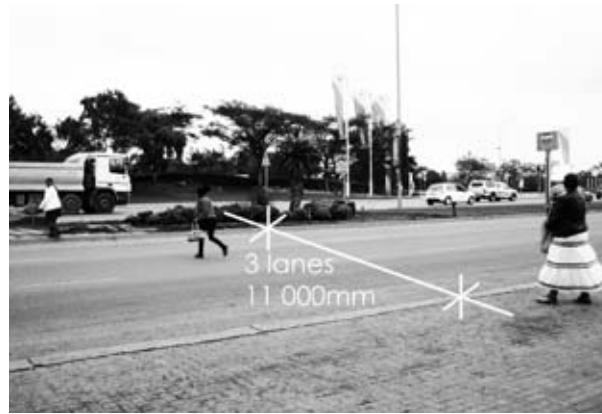

ILLUS. 1.4: Pedestrians jaywalking on Atterbury Road.

1.1 PROBLEM STATEMENT

According to the City Planning Committee (2002: 3), major transportation and land use problems are experienced in the Menlyn precinct in Tshwane. Current infrastructure allows motor vehicles to dominate public transport and pedestrian thoroughfare. Pedestrians and motor vehicles are placed in danger and traffic problems are created when taxis and buses make use of road lanes and sidewalks to stop (illus. 1.3-5). The interaction and superposition of these problems are manifested as a fracture in the urban framework, disconnecting people, environments and different transport modes from one another and the rest of Tshwane.

1.2 BRIDGING THE FRACT[URE]

The aim of this project is to address the fractured experience in the Menlyn area with the design of a Gautrain Platform Building at Menlyn. This Gautrain Platform Building should form part of an intermodal transport exchange. The project should respond to the poor connectivity and transport problems currently experienced in Menlyn and reinforce Menlyn as an important node within Tshwane. The project will not only address the functional aspects of a Gautrain Platform Building, but will also apply theories of thought that will contribute to the design concept and final design.

Project specifications

Client:

City of Tshwane

Site:

Erf Number 69, Menlyn

Programme:

Intermodal Transport Exchange

GPS Coordinates:

-25°47'6.12"S, 28°16'49.79"E



ILLUS. 1.5: Bus shelter on Atterbury Road.

ILLUS. 1.6: Road network of Menlyn area contributes to a fractured experience of the area.

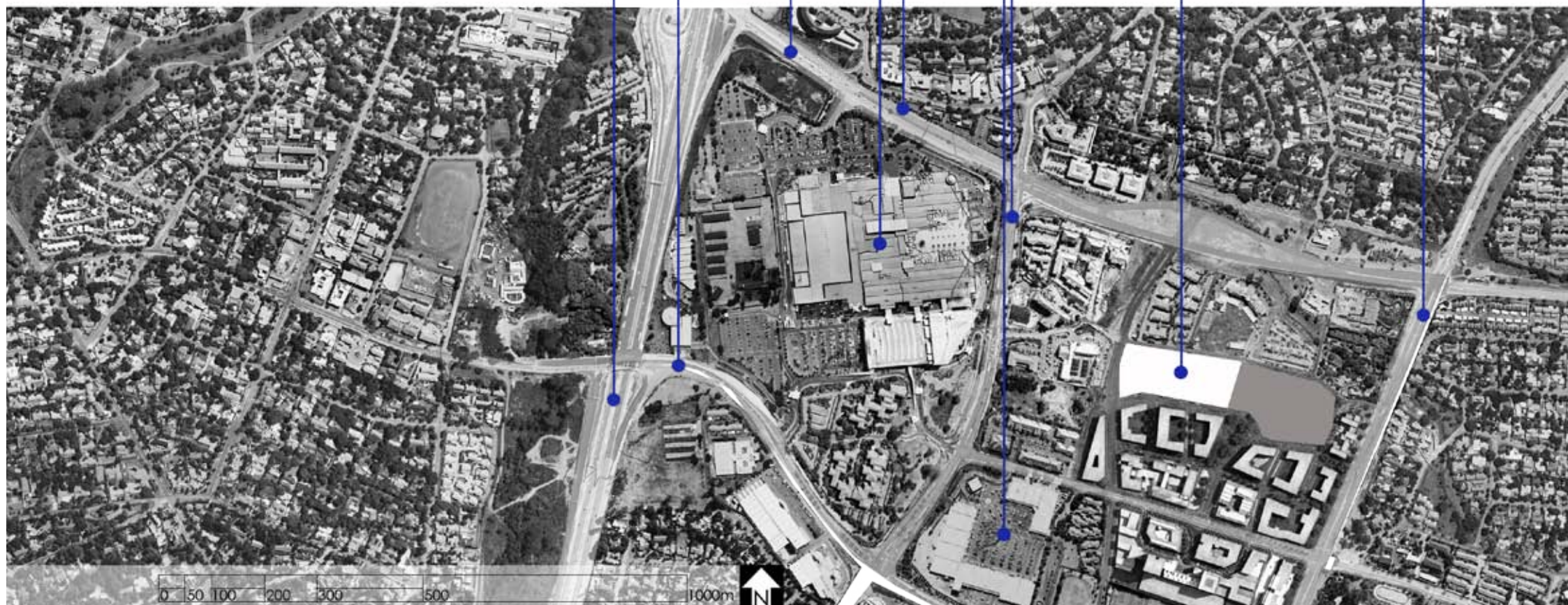

1.3. HYPOTHESIS

A Platform Building at Menlyn could integrate the various transport systems present in the Menlyn precinct with the envisioned Gautrain station.

1.4 LITERATURE

The literature studied focuses on intermodal transport exchanges and indicates that the design of transport exchanges spans across different disciplines and scales. Urban designers, architects, landscape architects and transport engineers have contributed to the understanding and design of intermodal transport exchanges. Design interventions range from urban frameworks, for example Los Angeles Gateway Center (1995) by The Olin Partnership and Fong & Associates in the USA

(illus. 7-8) (Thompson, 1997: 110), to a series of bus shelters, as in Dundee's Central Bus Exchange (2004) by Nicoll Russell Studios in England (illus. 9-10) (Evans, 2005: 34). Transport exchanges are often approached from a pragmatic point of view, engineering principles are employed that do not necessarily address the problem with architectural depth and innovative ideas.

Zaha Hadid's completed design for the suburban transport interchange, Terminus Hoenheim-Nord (2001) (illus. 11-12) in Strasbourg serves as an example where innovative architecture and pragmatic requirements meet (Giovannini, 2001: 136). The design "dissolves the distinction between art and architecture" (Fairs, 2001: 40) and clearly illustrates the concept of intersecting force fields.

ILLUS. 1.7; Entrance to Union Station at Los Angeles' Gateway Center.

ILLUS. 1.8: Aerial photograph of Gateway Center.

ILLUS. 1.9: Bus Stop at Dundee Central Bus Exchange.

ILLUS. 1.10: Aerial photograph of Dundee Central Bus Exchange.

ILLUS. 1.11: Hoenheim-Nord Station.

ILLUS. 1.12: Aerial photograph of Hoenheim-Nord Station.

ILLUS. 1.7:



ILLUS. 1.9



ILLUS. 1.11



ILLUS. 1.8

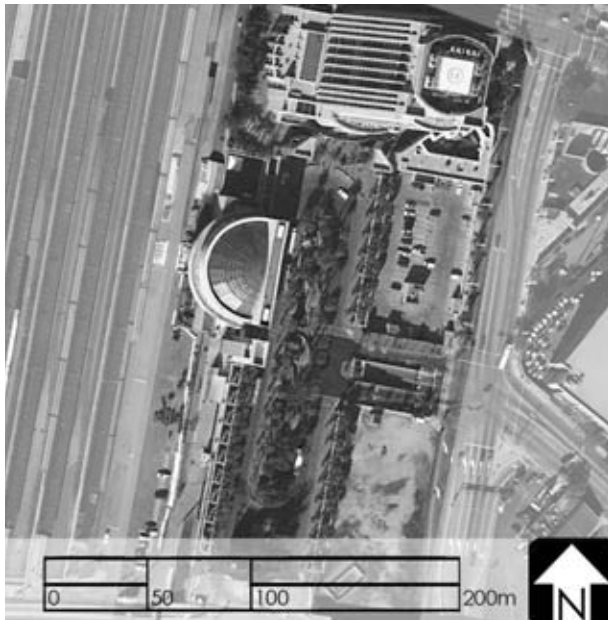

Los Angeles Gateway Centre

Programme: Intermodal transportation hub
Capacity: 1 500 busses/day, 3 000 motor vehicle parking bays; **No. of users per day:** 115 000

ILLUS. 1.10



Dundee Central Bus Exchange

Programme: Bus exchange
Capacity: 12 bus stops
No. of users per day: 12 000

ILLUS. 1.12

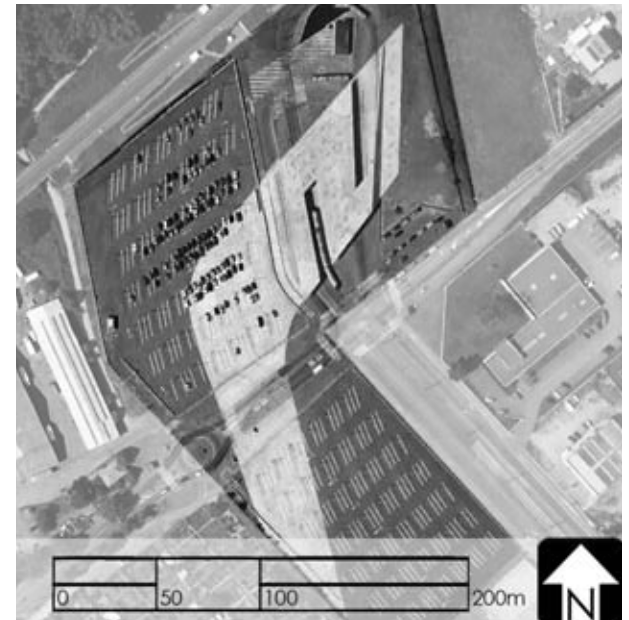

Hoenheim-Nord Station

Programme: Intermodal transport terminus
Capacity: 700 motor vehicle parking bays
No. of users per day: 50 000

1.5 METHODOLOGY

1.5.1 RESEARCH METHODOLOGY

- Investigate current transport system (with focus on the Menlyn precinct).
- Identify key issues and shortcomings surrounding accessibility and connectivity within the Menlyn precinct.
- Develop a theoretical approach.
- Investigate relevant precedents, literature and solutions.
- Use and apply information that was collected to propose a final design solution.

1.5.2 DELIMITATIONS

The following delimitations will be applied to the study and final design:

- The site of the Menlyn Gautrain Station is within the boundaries formed by Atterbury Road, Genl. Louis Botha Drive, Garsfontein Road and Lois Avenue.
- The envisioned underground Gautrain station will exit into the Platform Building at Menlyn.
- The Menlyn Maine development is accepted as part of the urban framework (and is considered complete and functioning).
- For the purpose of the investigation, pedestrians will be regarded as a mode of transport.

ILLUS. 1.13: Context plan. (Opposite)

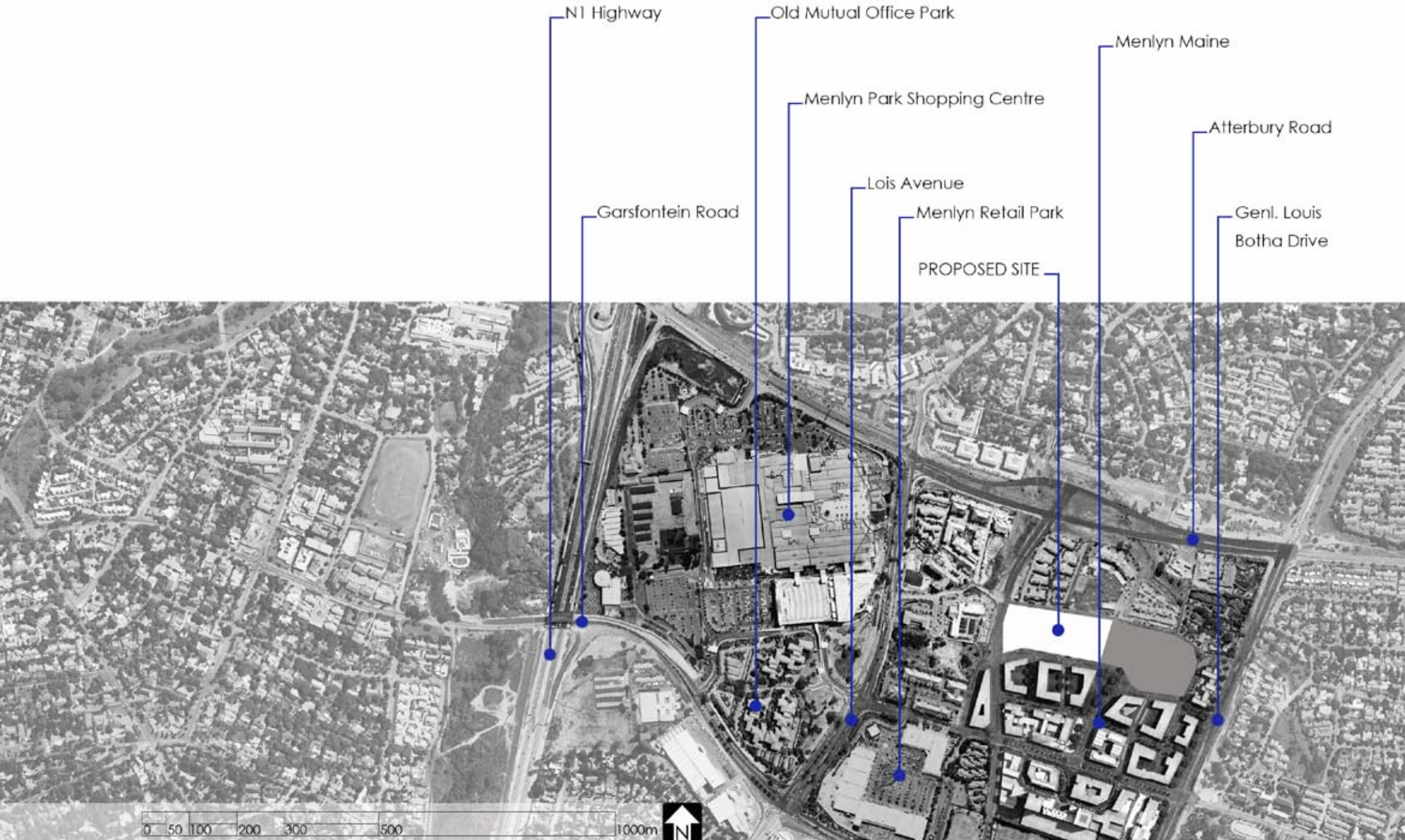

CHAPTER 2

REVIEW & REASONING

In this chapter the functioning of transportation in the Menlyn precinct will be reviewed. The reasoning behind this dissertation will also be presented as motivation for the architectural design response that follows.

2.1 BACKGROUND

The layout of the city of Tshwane includes numerous suburbs, many of which are located on the outskirts of the city. According to Atash (1996: 39) this layout leads to the decentralisation of the residential households. This decentralisation is inherently pursued by various retailers and other employers, leading to the forming of multiple nodes within a city.

One of Tshwane's nodes is located in the Menlyn precinct, situated in Pretoria East (illus. 2.1). The

Menlyn Park Shopping Centre, located next to the N1 highway, forms the main attractor of this commercial node. The study takes the area's existing commercial and business functions as well as the neighbouring residential areas into consideration.

ILLUS. 2.1: Greater context indicating urban nodes, stations and surrounding suburbs. (Opposite) .

Menlyn Park Shopping Centre

Date of opening: 1979, refurbished 1998

No. of visitors:

1,5 million monthly

No. of parking bays:

3 135 covered bays

2 088 open bays

5 223 total

No. of shops:

273

Gross Letable Area (GLA):

1 18 253m²

Unique Selling Points:

Outdoor events arena, play park, rooftop drive-in

(Mallguide.co.za, 2008)

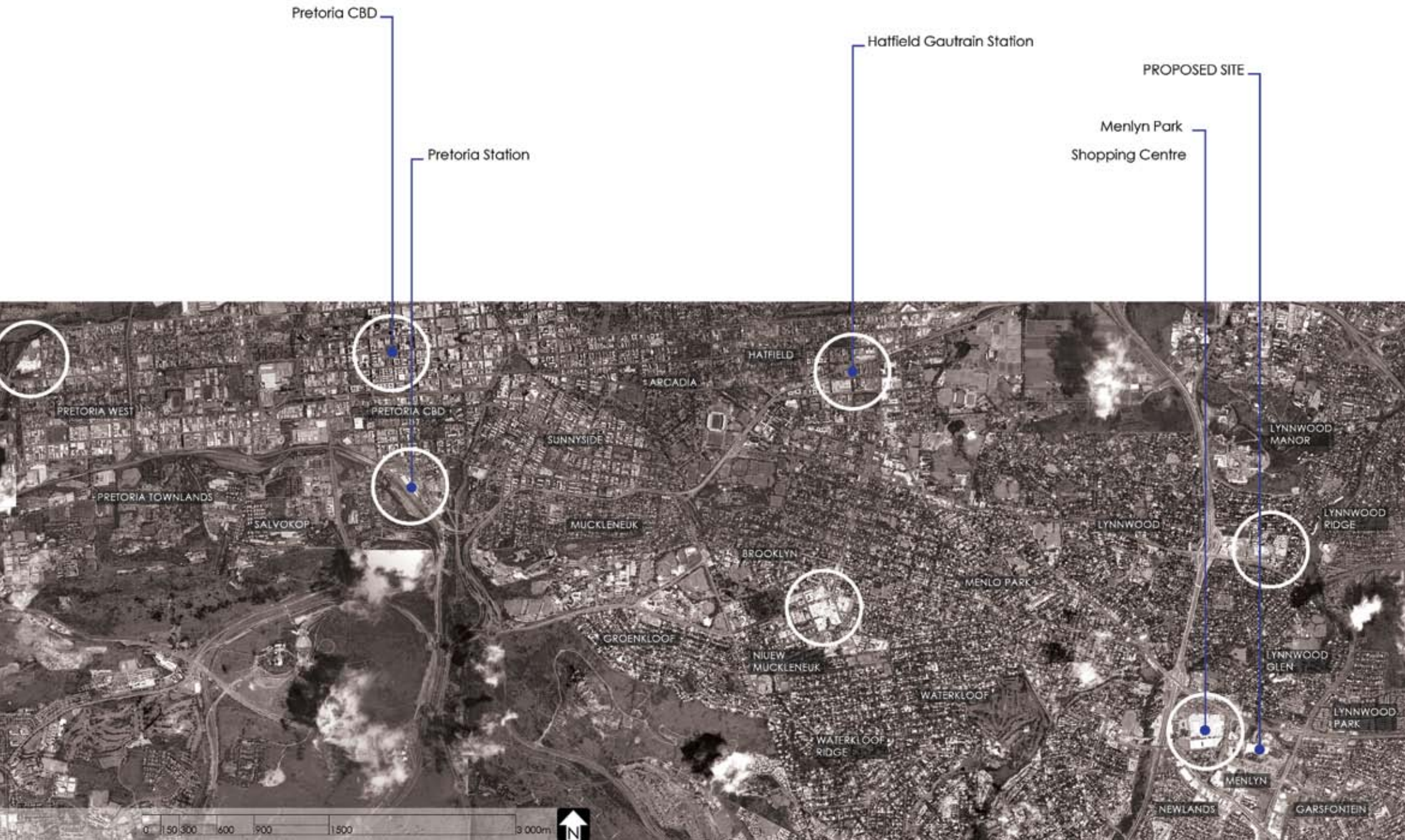

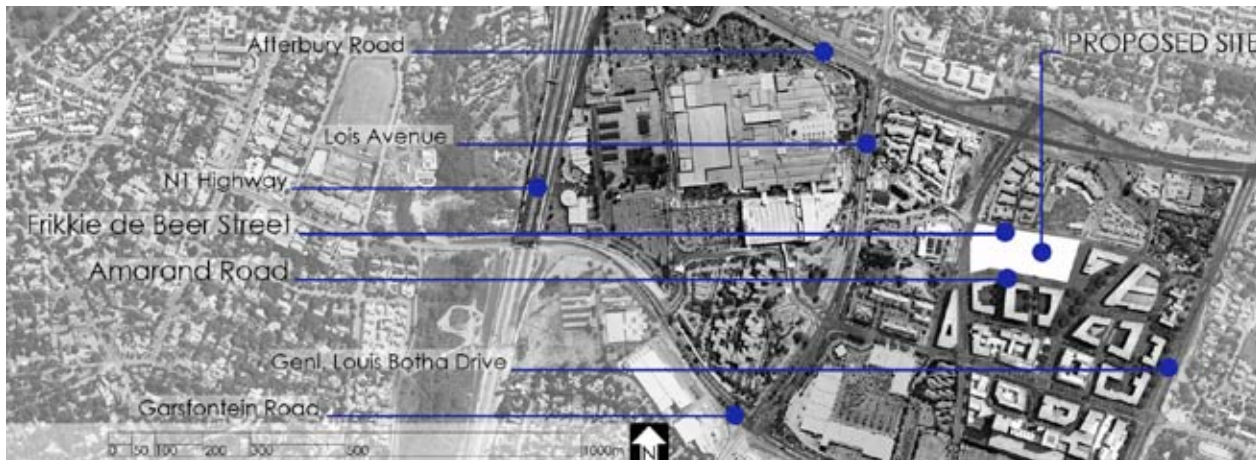

ILLUS. 2.2: Location of proposed site. (Left)

ILLUS. 2.3: Plan of Menlyn precinct indicating walking radii from site, existing transport and the location of the future Menlyn Gautrain Station. (Opposite) .

2.1.1 CONTEXT

The proposed site is situated in the Menlyn precinct (Pretoria East). Frikkie de Beer Street and Amarand Road form the Northern and Southern site boundaries (illus. 2.2). The site forms part of an urban framework for the block bounded by Atterbury Road, Genl. Louis Botha Drive, Garsfontein Road and Lois Avenue.

The site is in close proximity (15 minute walking distance) of the following existing facilities/uses:

- Menlyn Park Shopping Centre, one of the region's biggest shopping centres.
- Menlyn Retail Park, a retail centre.
- Menlyn Maine, a mixed-use Green Star SA certified lifestyle development.
- Residential Neighbourhoods.
- Educational Facilities - The Glen High School and Damelin College.

Within the Gautrain development framework, the Menlyn precinct has been identified as the location of a station for the extension of the Gautrain Rapid Rail Link (Gautrain, 2011a). In addition, Menlyn is the location of various informal taxi ranks, has multiple bus routes traversing the area and is close to the N1 highway.

Urban Node: Lynch (1975: 47) describes nodes as strategic spots within a city to and from where people travel. Nodes are also described as concentrations of important functions.

Nodacity.com (S.a) indicates that a node is a meeting point of a group or collection of things.

In transportation terms, van der Laan (1998: 239) argues that a node is identified where a high level of incoming and outgoing commuting takes place. For the purpose of this dissertation a node will be regarded as a concentration of important urban functions (employment, retail and transport). This concentration overlaps with a (wider) point to and from which people commute on a daily basis.

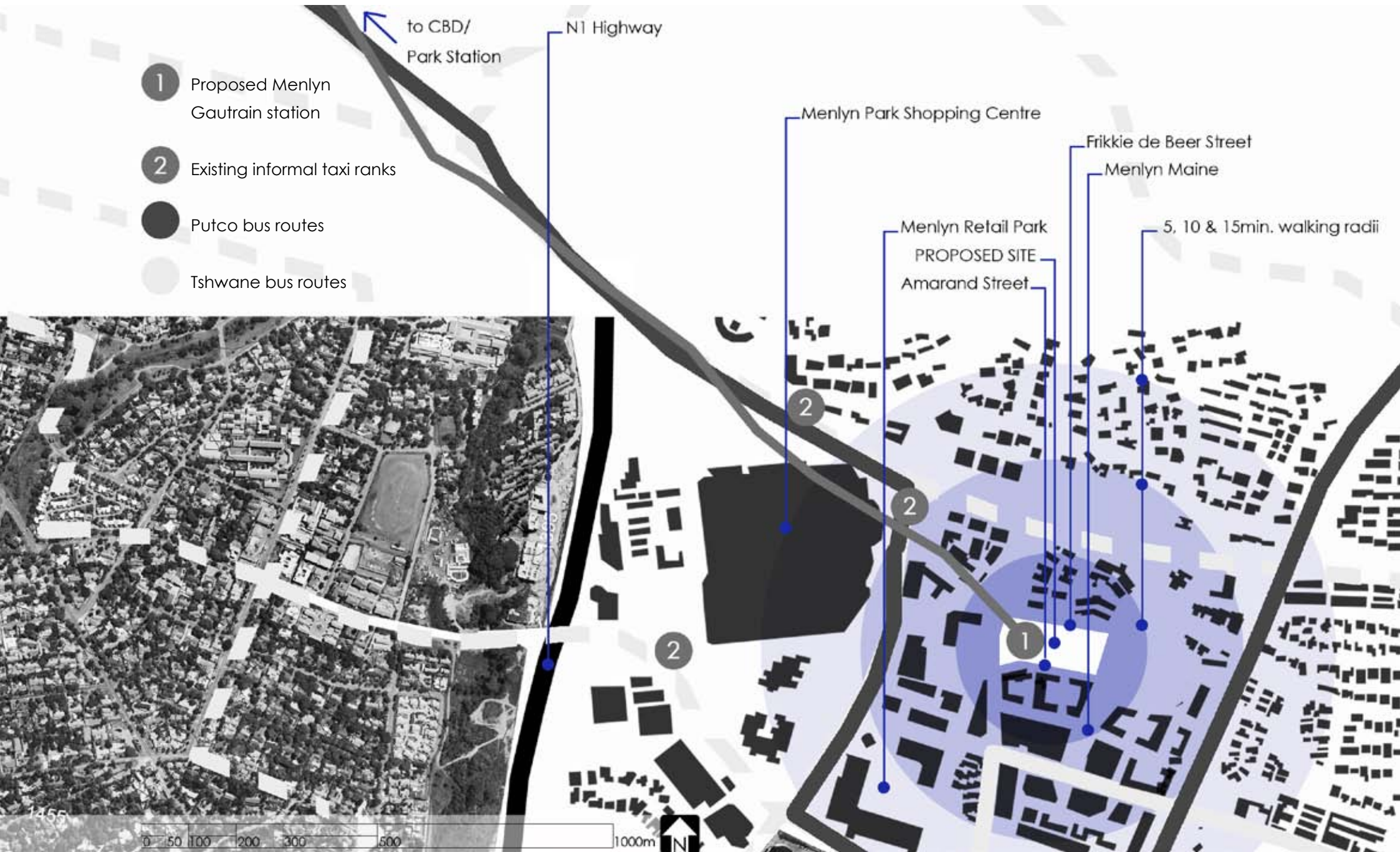

City block characteristics				
City	Length (m)	Width (m)	Accessible by public transport	Accessible by train
Cape Town CBD	80	70	Yes	Metrorail
Durban CBD	200	100	Yes	Metrorail
Johannesburg CBD	70	70	Yes	Metrorail
Menlyn Precinct	800	800	Yes	No
New York CBD	120	60	Yes	Subway
Tshwane CBD (Pretoria)	230	150	Yes	Metrorail

TABLE 2.1: Comparison of city block sizes, accessibility and users. (Author, 2011)

ILLUS. 2.4: Comparison of existing street layouts for Pretoria CBD (grid) and Menlyn precinct (free flowing). (Opposite)

2.1.2 THE INFLUENCE OF THE MOTOR VEHICLE ON CITY LAYOUT

The motor vehicle is one of the most important inventions of the 19th century (Parrack, 2010). It has become a part of everyday life and has changed the shape of our cities, including Pretoria. This however should not be confused with private car ownership.

Before the 1950's, when highways were first introduced, cities were structured and planned with the CBD (Central Business District) as focal point. Inhabitants of the city made use of public transport to travel to and from the CBD. Suburbs were located close to the CBD and were linked to the public transport system. The Pretoria CBD illustrates this with a grid layout that is immediately surrounded by suburbs that are easily served by public transport (Pretorius,

2000: [9]).

The 1960's were characterised by a preference for the private motor vehicle. Private vehicle ownership along with the introduction of highways led to the creation of suburbs further afield, such as Menlyn. These suburbs' layouts were done with private motor vehicles in mind (ibid.). This resulted in free-flowing street layouts, which does not encourage effective integration of public transport (illus. 2.4).

2.1.3 ESTABLISHMENT OF MENLYN AS A NODE

The implementation of the N1 highway during the 1960's enabled the birth of new suburbs further away from the Pretoria CBD. These new suburbs were in need of a commercial entity in close proximity and led to the approval of the Menlyn Hyperama retail outlet, now Menlyn

Park Shopping Centre. This new shopping centre initiated Menlyn as a new development node within Pretoria (City Planning Committee, 2002: 3).

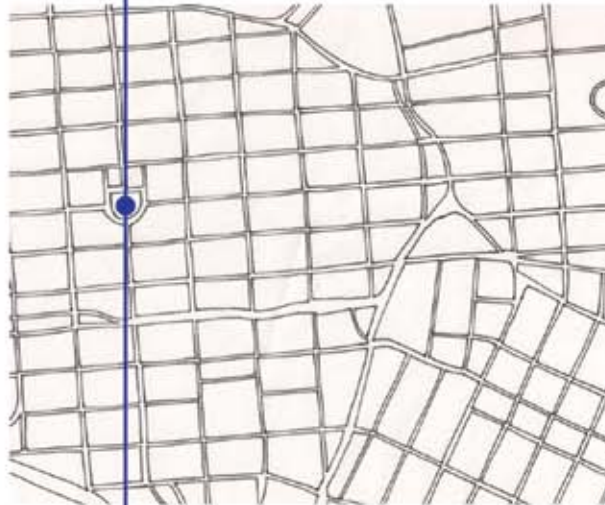
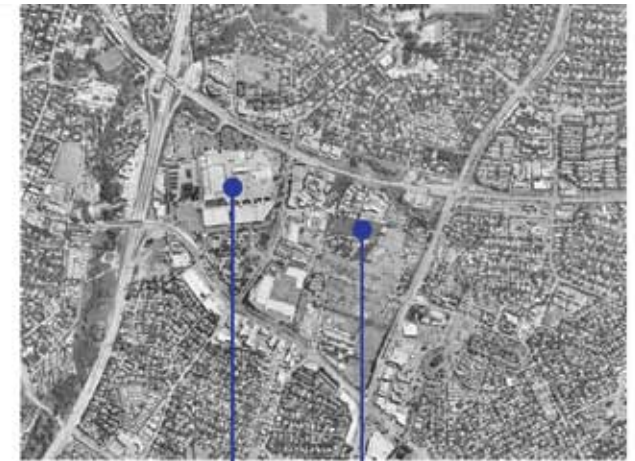

Menlyn Park Shopping Centre
Church Square

Church Square (grid layout)

Menlyn Park Shopping Centre (free-flowing layout)

PROPOSED SITE

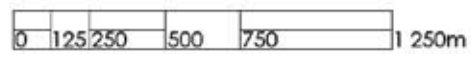

Jaywalking: Term used for illegally crossing a road at a point other than an intersection or pedestrian crossing (Walkinginfo.org, 2007; Ntholeng, 2011).

2.1.4 MODES OF TRANSPORT

The modes of transport that will be included in the Menlyn Intermodal Transport Exchange, of which the Gautrain Platform Building at Menlyn forms part, are:

- Pedestrian
- Motor vehicle
- Taxi
- Bus
- Gautrain

A brief description of each of these modes will be presented next.

PEDESTRIAN

The Menlyn node was developed during an era characterised by a distinct bias favouring the motor vehicle (Pretorius, 2000: [9]). Although it is possible for pedestrians to navigate the



ILLUS. 2.5: Route to pedestrian stairway.

area, the effect of this bias was to exclude and disregard the role of the pedestrian in the design and development of the area. It is common for pedestrians to jaywalk. This is a direct contribution to the number of road accidents in Gauteng (Department of Transport, 2009: 30).

To gain direct insight into the factors contributing to the experience a pedestrian may have of the area, the Menlyn precinct was navigated on foot by the author. A summary of this exercise is shown in illus. 2.11.

Informal interviews with pedestrians in the area and personal observations assisted the author to compile the following list of factors influencing the pedestrian experience of the area:

- Shopping centres are mostly introverted,



ILLUS. 2.6: Sidewalk obstructed by infrastructure.

surrounded by parking lots and garages through which pedestrians are forced to enter (illus. 2.6-7).

- Pedestrian crossings are spaced at intervals of approximately 400-800m.
- Pedestrians are rendered vulnerable by the placement of sidewalks directly next to three- and four lane roads (illus. 2.6,8&9).
- Taxis often make use of sidewalks to stop, forcing pedestrians onto the road.
- Bus shelters are located directly on sidewalks, leaving limited room ($\pm 300\text{mm}$) for pedestrians, forcing them onto the road (illus. 2.8).
- Size of city blocks within the Menlyn precinct are large in comparison with other cities' blocks. This observation is confirmed by the data in table 2.1.



ILLUS. 2.7: Pedestrian path through parking garage.



ILLUS. 2.8: Bus shelter located on sidewalk.



ILLUS. 2.9: Three-lane road with jaywalker.

ILLUS. 2.10: Aerial map of route.

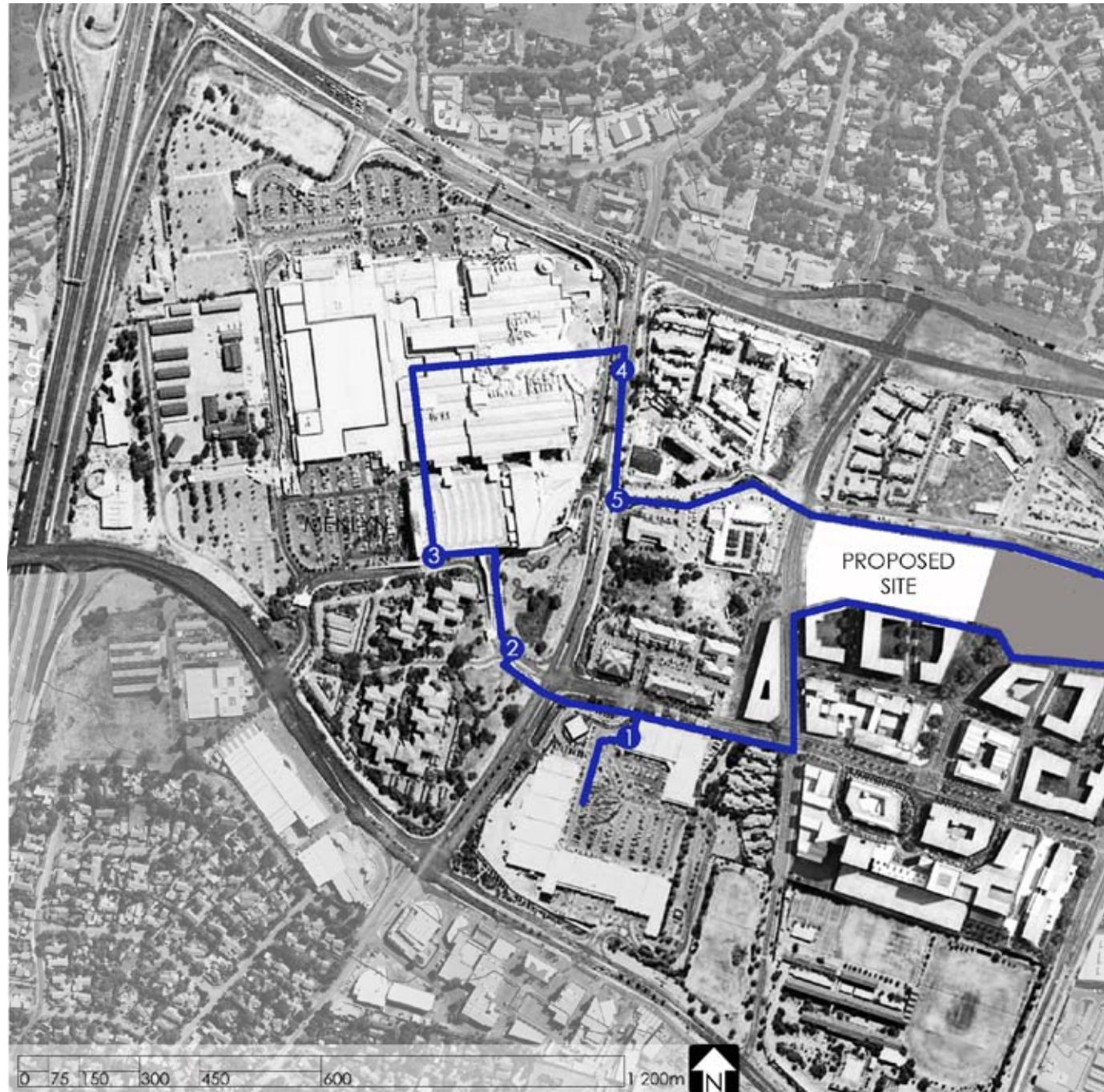

Hierarchy of Roads

- ① N1 Highway
 - ② Arterials: North - Atterbury Road
South - Garsfontein
 - ③ Secondary Arterials:
East - Genl. Louis Botha Drive
South - Aramist Road
West - Lois Avenue
 - ④ Future upgrade - Dallas and Atterbury Roads
- P Formal pedestrian crossing
- T Informal taxi stop

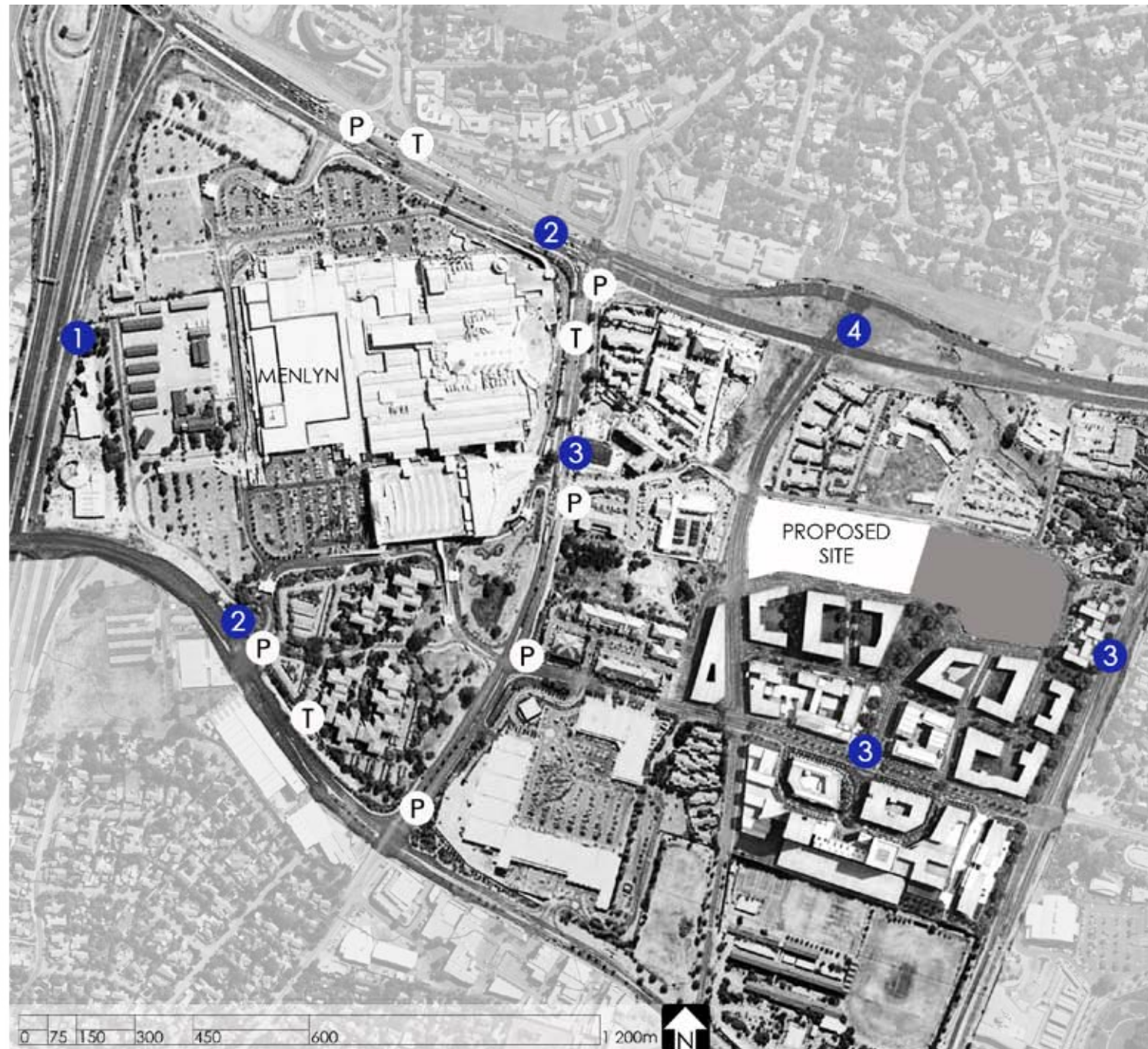

ILLUS. 2.11: Hierarchal layout of roads in Menlyn; Existing informal taxi ranks and formal pedestrian crossings.

Type of Road	Distance between (km)	Speed (km/h)	Private Access	On Street Parking
Highway	8 – 10	80-120	No	No
Major Arterials	2.5 – 3.0	100	Minimal	No
Minor Arterials	2.5 – 3.0	80 - 100	Minimal	No
Collector	1.0	60	Yes	Yes
Local Streets	0.3 - 0.5	40 - 60	Yes	Yes

TABLE 2.2: Hierarchy of roads (Personal communication with Pretorius, 2011.)

MOTOR VEHICLE

During recent years, the Menlyn precinct has undergone rapid growth and traffic problems have escalated accordingly. (City Planning Committee, 2002: [9]). Upgrades of major arterial roads (table 2.2) such as Atterbury and Garsfontein Roads together with the N1 highway have improved existing traffic problems. The future upgrade of Dallas Road, a minor arterial, could improve the accessibility of the Menlyn precinct (Illus. 2.9) (City Planning Committee, 2002: [18]).



ILLUS. 2.12: History of mini-bus taxi industry. (Left)

ILLUS. 2.13: Lois Avenue taxi stop. (Below)



TAXI

The mini-bus taxi industry originated during the 1970's (illus. 2.12) to meet the transportation demands of people living on the city outskirts (International Labour Organisation, 2003: 8). Currently, 66% of all public transport users make use of mini-bus taxis (International Labour Organisation, 2003: 9). The minibus (15- and 18 seater) taxi is the most common form of public transport in South Africa (International Labour Organisation, 2003: 4).

In the Menlyn precinct, there are currently three informal taxi ranks (or stops) operating between Menlyn, the Pretoria CBD and Mamelodi. These taxi stops cause disruptions to normal traffic. Taxis often block buses from accessing existing bus stops and sidewalks are used as taxi parking bays. Furthermore, taxi and bus stops

are located far from designated pedestrian crossings - resulting in jaywalking (page 14).



ILLUS. 2.14: Atterbury Road taxi stop.

- BRT
- Tshwane bus
- Putco

ILLUS. 2.15: Plan of existing bus routes at Menlyn precinct.

BUS

The Menlyn node is intersected by four important roads connecting it to the surrounding suburbs and to urban destinations further afield (illus. 2.15). Many Tshwane municipal bus routes are located in the Menlyn node and connect the surrounding suburbs with the Pretoria CBD. Putco bus routes also traverse the area and connect the Menlyn node to Mpumalanga, Mamelodi and the Pretoria CBD.

Pretorius (2000: [2]) states that the following characteristic shapes the nature of cities: people “do not like to travel more than half an hour to major urban destinations”. The National Household Transport Survey (2007: 30) however indicates that the majority of Tshwane’s residents take longer than 30 minutes to travel to work (Table 2.3).

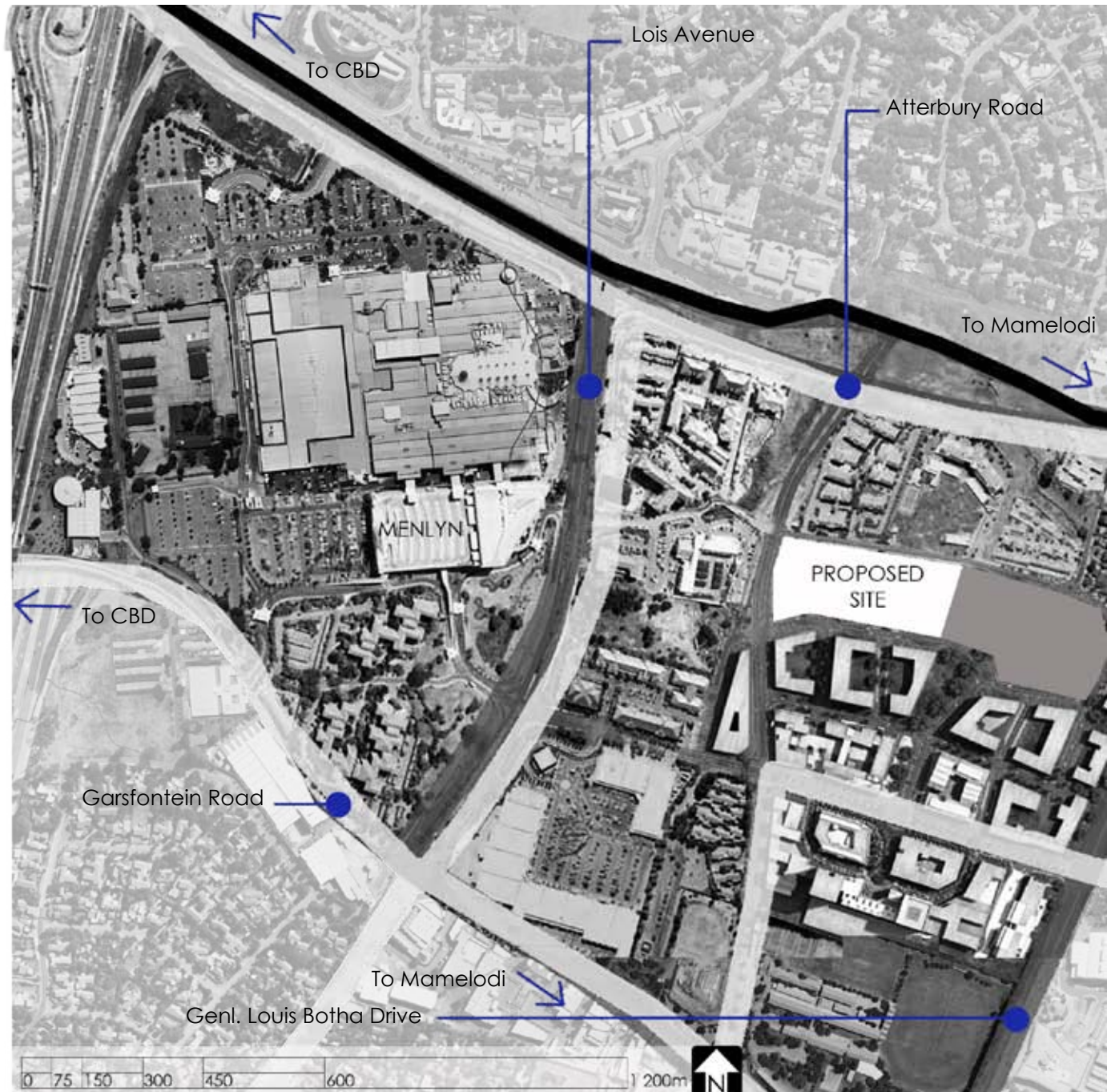

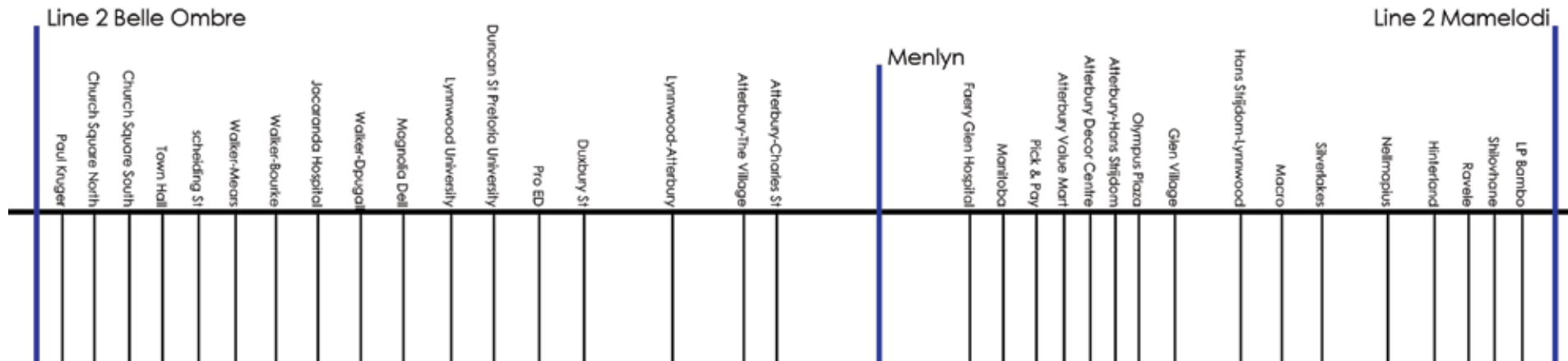

ILLUS. 2.16: BRT Route Line 2.

TABLE 2.3: Travel times to work (National Household Survey, 2007: 30).

	<16 mins	16-30 mins	31-60 mins	61-90 mins	91-120 mins	>120 mins
City of Tshwane	10.5%	25.8%	37.9%	14.4%	7.0%	4.5%

The Bus Rapid Transit (BRT) system is planned to shorten this time, by introducing busses that will operate in dedicated bus lanes and minimise time spent in traffic. One of the planned BRT bus routes will travel through the Menlyn area and would encourage the use of public transport as well as the development of a transport corridor between Menlyn and the CBD (Engineering News, 2007; Advanced Logistics, 2008) (illus. 2.16).

GAUTRAIN

The existing Gautrain Rapid Rail network comprises of two links. The first link is between Pretoria and Johannesburg and the second link is between OR Tambo International Airport and Sandton. The Gautrain forms part of one of eleven Blue IQ projects of the Gauteng Provincial Government. These projects aim to enhance economic growth, create job opportunities and to integrate the Gauteng transportation network (Gautrain, 2011b).

Presently, the last stop of the Gautrain, between Johannesburg and Pretoria, is Hatfield station. The route was designed for possible future extension from Hatfield to Menlyn. However, the precise location of the Menlyn Gautrain Station has not yet been determined. What is known about the future station is that it would be situated underground and within the proposed framework area.

The establishment of the Menlyn Gautrain station should enable a stronger connection with Pretoria CBD and Gauteng. This connection could serve the Menlyn node of Tshwane and possibly stimulate economic growth locally and within other connected areas. The Gautrain aims to create and sustain a new culture of public transport usage (Gautrain, 2011b).

● Gautrain



ILLUS. 2.17: Plan of underground Gautrain route at Menlyn precinct.

2.2 MOTIVATION

“Major transportation and land use problems associated with the [Menlyn] node are presently experienced” (City Planning Committee, 2002: [1]). Although most transportation modes are present in the area, a lack of public transportation and pedestrian accessibility is still experienced (City Planning Committee, 2002: [3]).

The integrated improvement and cohesion of the various transport modes in the Menlyn area could benefit the greater Tshwane. In the next section, Transit Oriented Development as a means to address transport integration within an urban framework, is investigated.

2.2.1 TRANSIT ORIENTED DEVELOPMENT

A transit oriented development (TOD) refers to mixed-use, high density development located walking distance (400m or 5minutes) of a transport node. TOD assists with the access to transport facilities and increases the use of public transportation systems (Goodwill, 2002: 7). TOD could be used as a tool for transport integration. It focuses and attempts to amalgamate and establish proper communication between different modes of transport.

Newman (1996: 5), and Goodwill (2002: 9), claim that TOD makes economic sense, citing amongst others, the following reasons:

- Investment in public transportation infrastructure has double the economic benefit of investment in highways
- Transportation infrastructure can make it

possible for a city to increase its density in areas near transportation nodes where most services are located, thereby creating more efficient city nodes as well as minimising urban sprawl.

2.2.2 DESIGN INTENT

An intermodal transport exchange could fuse the fracture between the different areas, transport modes and people of Menlyn. Furthermore, it could be argued that a Platform Building for the Gautrain stop at the Menlyn Intermodal Transport Exchange should improve the connection and accessibility experienced between Menlyn, Tshwane and Gauteng as a whole.

2.2.3 AIMS AND OBJECTIVES OF THE REMAINDER OF THE STUDY

- Use and apply data and knowledge obtained during the period of investigation to design a Gautrain Platform Building at Menlyn.
- Determine the needs of the users of a Gautrain Platform Building at Menlyn.
- In response, design a Gautrain Platform Building that will meet the needs of its users.
- Create a facility that is accessible, safe and legible to frequent users as well as visitors.

CHAPTER 3

THEORETICAL ARGUMENT

In this chapter, the theoretical argument is developed. Transportation systems are abstracted and analysed alongside mathematical concepts and principles. These principles will be extended and used as design tools.

3.1 COMPLEX SYSTEMS

Complex systems contain such an abundance of activity that the human brain is unable to fathom all the different possible outcomes. (Uitenbogaard, 2011). These systems involve many components that interact with one another and the collective behaviour cannot be determined from analysing a single component (Rocha, 2003).

The transport system present in the Menlyn precinct is an example of a complex system

(illus. 3.1). The different modes could be grouped into three categories:

- random - routes followed are undetermined
- probabilistic - routes followed are undetermined, but take place within a structured framework
- deterministic - routes are determined

The behaviour of the combination of these three groups together with their users cannot be anticipated and therefore forms a complex system which can be described as chaotic (Frazier & Kockelman, 2004: 1).

Chaos takes place when systems are sensitive to their initial conditions and when the outcome of these systems is indeterminate.

ILLUS. 3.1: Current Menlyn precinct transport system as complex system. (Below)



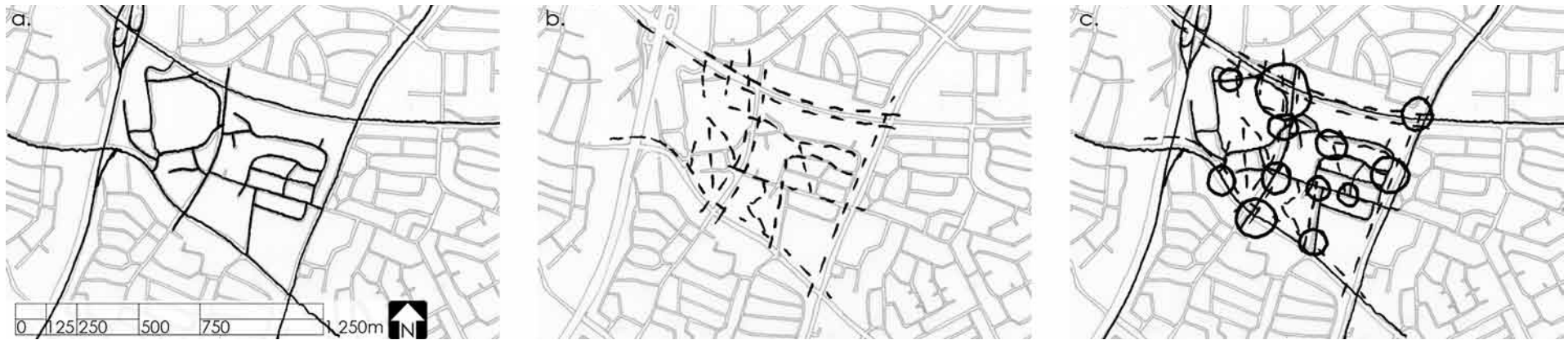

ILLUS. 3.2: Current Menlyn precinct transport system as chaotic system. a: Vehicular movement. b: pedestrian movement. c: Attractors/points of connection.

3.2 CHAOS THEORY

Chaos theory originated in the 1960's and this field of mathematics studies complex systems (Uitenbogaard, 2011). Chaos theory is used to analyse and understand complex systems and seeks to identify the underlying order within seemingly random systems (Rae, 2008). An advantage of chaos theory is that it could be used to reveal system information and relationships within a system without having to discover new laws or equations (Frazier & Kockelman, 2004: 1). Within a complex system, the information that is revealed usually consists of some sort of order. This order is termed the 'attractor' and within chaotic systems often presents itself as a self-repeating or self-similar pattern or fractal (ibid.: 2).

Frazier & Kockelman (2004: 1) state that chaos theory may be useful in gaining a deeper understanding of transportation systems. Disassembled into single paths and transport modes, it is easy to understand transport networks, but the layering and interaction of various networks easily becomes very complex.

Given that "pathwise connectivity is most economical on a plane surface" (Salingaros, 2003: 12), different transportation networks are in competition with each other; sharing, meeting and crossing each other's paths. The competition formed by the interlacing of these networks results in chaos and adds dynamics to the system that cannot be understood by investigating only the system parts.

The aim of any transportation system is to connect people and places with one another. The attractor or underlying order of transport networks could be interpreted as 'connection' (illus. 3.2).

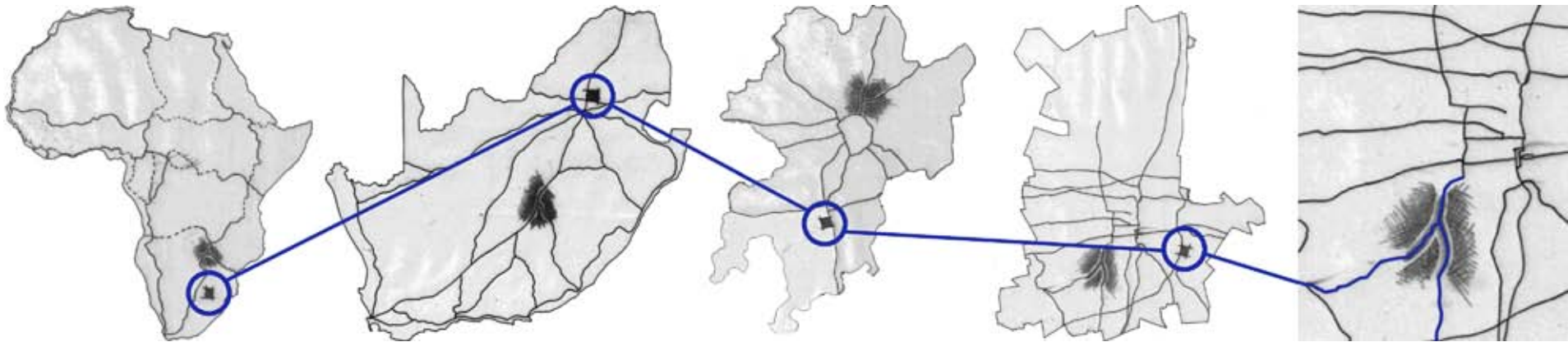

ILLUS. 3.3: Self-similarity of road connections across different scales. Important road networks of Africa, South Africa, Gauteng and Tshwane respectively.

3.3 FRACTALS

As mathematical shapes, fractals present the fascinating property of being “both very simple and infinitely complex at the same time” (The Fractory, S.a). Bovill (1996: 3) defines fractal geometry as “the study of mathematical shapes that display a cascade of never-ending, self-similar, meandering detail as one observes them more closely”. Fractals thus have the same pattern or properties at different scales and can even be said to render an object scale-less.

Bovill (1996: 3) states that fractals are integrated into our being to such an extent that our “senses, having evolved in nature's similar cascade, appreciate self-similarity in designed objects”.

Fractals are present in many architectural works, but are only deemed 'fractal' if built after 1970 when the concept was first investigated by mathematicians (Joye, 2007: 311).

With regards to design, fractals are interpreted as two-dimensional design inspirations. A pattern is chosen and repeated across the entire spectrum of the design. This interpretation seemingly lacks depth and the question as to how fractals can contribute to meaningful architecture arises. The mathematician who first identified the concept of fractals, Mandelbrot (1924-2010) in Bovill (1996: 115), hints at a possible answer to this question by stating that fractals in architecture refers to a progression of interest from the very large to the very small scale, a mix of order and surprise.

The aim of a Gautrain Platform Building at Menlyn is to connect people and places with one another. The idea of connection, if applied to different scales within the design, would result in a fractal concept of connection (illus. 3.2-3).

ILLUS. 3.4: Collage of images indicating self-similarities in Menlyn precinct. (Opposite)



ILLUS. 3.5: Palais de Justice, Nantes (2000), by Jean Nouvel. Progression of interest at different scales.



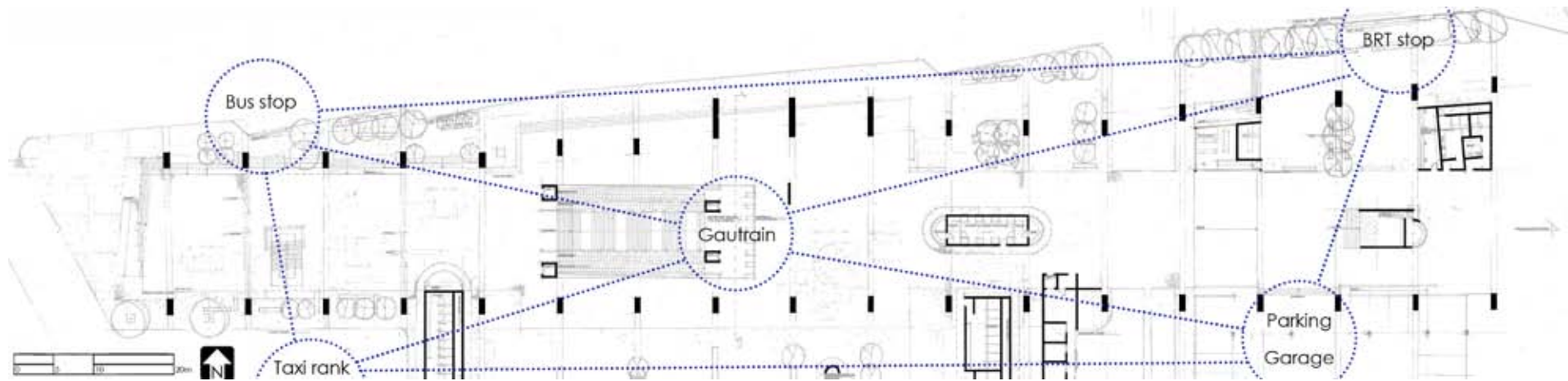

3.4 SMALL-WORLD NETWORKS

Salingaros (2003: [1]) states that “cities have intrinsically fractal properties”. He argues that the automobile has contributed to the creation of anti-fractal urban typologies (car cities) in the 20th century, which destroyed the fractal nature existing in cities.

Salingaros (2003, [2]) is of the opinion that pre-modernist cities can be described as fractal or pedestrian cities, “because they work on all scales”. Traditional urban form was an effect of the pedestrian transportation web, with the addition of incremental additions, for example, a rail or tram network. Modifications to the transportation systems lead to transformations of the city structure. Technical aspects and flows of vehicles are used as the central concept of design of modern transportation infrastructure

(Van der Spek, 2006: [1]).

To reintroduce the pedestrian city, “one has to rebuild a new pedestrian network into the car city” (Salingaros, 2003: [6]). Dupuy in Salingaros (2003: [7]) states that a city's life is determined by its connectivity. One could argue that the motor vehicle increases the connectivity of a city, ironically the motor vehicle actually isolates a person from his/her surroundings, and 50% of the urban surface is sacrificed for parking (Salingaros, 2003: [9]).

Small-world networks are networks “where nodes are connected by both long and short links” (Salingaros, 2003: [15]). Through the application of small-world networks to the urban fabric and especially the urban transportation network, multiple-connectivity

can be achieved between different nodes as well as different transportation modes and scales (illus. 3.5).

With the assurance of an urban framework and a design resolution that addresses the scale of all these modes, the design should become fractal.

3.5 CONCLUSION

Chaos theory, fractal geometry and small-world networks are seemingly abstract concepts with regards to architecture. Graafland (2008: 6) states that the “problem nestles in the ‘translation’ of these theories into meaningful practices”. The Platform Building at Menlyn is to make use of these theoretical principles to design a platform for the Gautrain users and users of other transport modes. Users

ILLUS. 3.6: Small-world network principles applied to design proposal. (Opposite)

ILLUS. 3.7: Principle of small-world networks applied to Tshwane. (Right)

would be able to transition and connect with one another as follows:

- Small-world network principles should be applied to both the urban framework and design proposal.
- A sense of continuity in the perception of users should be established as a result of self-similarity on various scales of the design.
- Self-similarity should be used as a tool whereby architectural legibility may be enhanced.

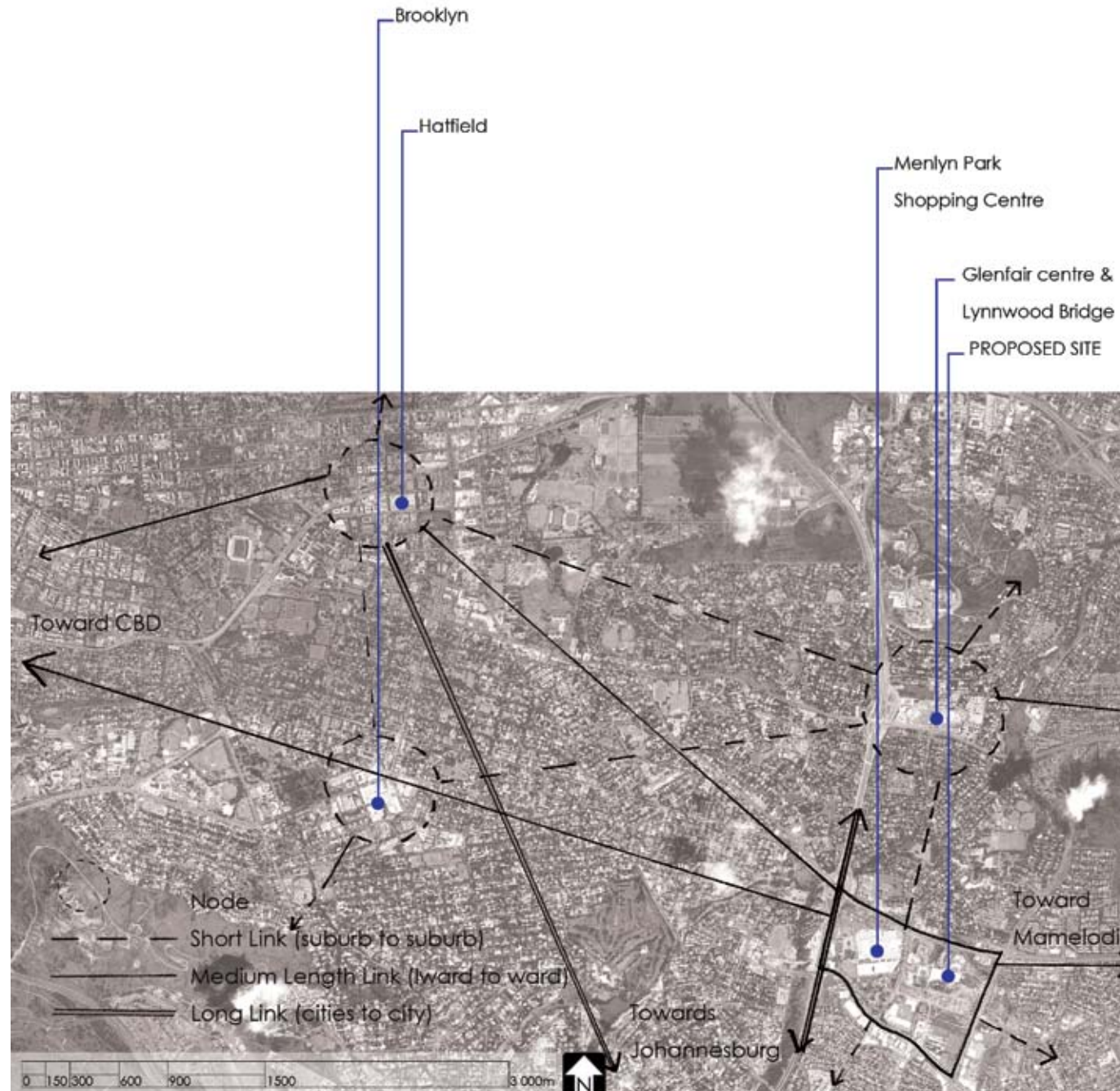

CHAPTER 4

CASE STUDIES & PRECEDENTS

“Insanity: doing the same thing over and over again and expecting different results.” - Einstein (Brainyquote, 2011)

In this chapter existing projects that relate to the design proposal will be investigated. These investigations will contribute the design guidelines of the project. The projects were chosen on the basis of their functional, geographical and theoretical relevance.

The initial precedent study related to intermodal transport exchanges and taxi ranks. The scope of the final design proposal evolved to a Platform Building for the Gautrain stop at Menlyn. New precedents were selected and investigated. The initial precedents are presented Appendix A (page 102).

In this chapter, the Sandton Gautrain Station and the manner in which it permits the Gautrain to interface with its surroundings is firstly presented. The station building is also discussed as an underground station and platform building.

Secondly, the Sandton Convention Centre will be investigated as a precedent of a public building where people congregate.

Lastly, the Palais de Justice in Nantes, France will also be investigated as an example of fractal geometry applied in architecture.

ILLUS. 4.1: Signage outside the Gautrain Sandton Station.



ILLUS. 4.2: Exterior of the Sandton Convention Centre.



ILLUS. 4.3: Interior of the Palais de Justice.



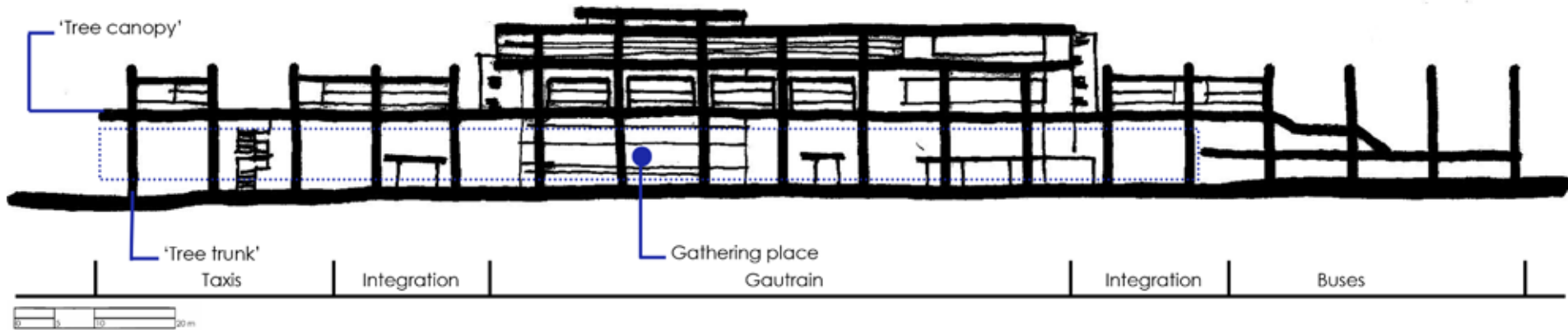

ILLUS. 4.4: Design application of Gautrain Sandton Station to the Platform Building at Menlyn. .

4.1 GAUTRAIN SANDTON STATION

At present, the Sandton Station is one of three Gautrain underground stations. Gautrain stations are designed in accordance with the Gautrain corporate brand and concept. This will now be explained in brief:

The idea of an African rural village forms the core concept of the station buildings. Communities and villages, just like individual stations, are linked by different paths. Along these paths, trees become important nodes and landmarks. They provide protection from the sun and are places for gathering (Gautrain, 2011d). For this reason the tree is an important symbol in the design of the different Gautrain stations. The column structures represent the tree trunks and support the 'wave'-like roof structure or 'tree canopy' (Bombela, 2008: 11).

The Gautrain Sandton Station is formed by a 48m deep rectangular shaft and 'cavern' on platform level. The shaft is covered by a triple volume glass and steel roof structure. This structure allows natural light to enter and is meant to attribute a sense of transparency to the station building (Bombela, 2008: 12). Whether this has been achieved is debatable. The approach of ground level from below ground is met with natural light, but the exterior of the building is not visible. The shaft is also not visible from the exterior of the building.

The exterior of the building is lightweight and glazed and is contrasted with a robust interior. The architects maintain a sense of diversity and modernity through the use of cleverly designed architectural details throughout the building (Gautrain, 2011d).

LOCATION:

Johannesburg, South Africa

COMPLETION:

2010

PROGRAM:

Gautrain Rapid Rail Link station

GROSS FLOOR AREA:

Unknown

ARCHITECTURAL TEAM:

Gautrain Architects JV

ARCHITECT(S):

Gautrain Architects JV

Transition space: Space that embodies two different conditions; a space that separates and connects different spaces and events. (Porter, 2004: 155).

ILLUS. 4.5: Photo collage of Gautrain Sandton Station.
(Below)

The entrance of the building is welcoming and spills the users out into the streets of Sandton. It has been observed that it is difficult for users to orientate themselves upon exiting the station building. As a platform, the Gautrain Sandton Station only caters for Gautrain users as a 'transition space'.

DESIGN APPLICATION

The Platform Building at Menlyn will not directly make use of the Gautrain corporate identity, but will make use of the concepts of Gautrain in a different manner. The building will be more than just a functional platform for the Gautrain. It will be a platform for connection between users of different modes of public transport as well as become a place of gathering such as the tree of the rural African village.

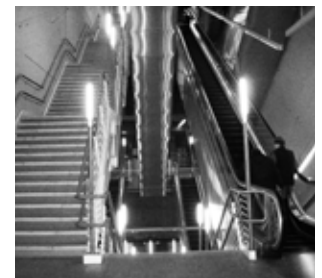
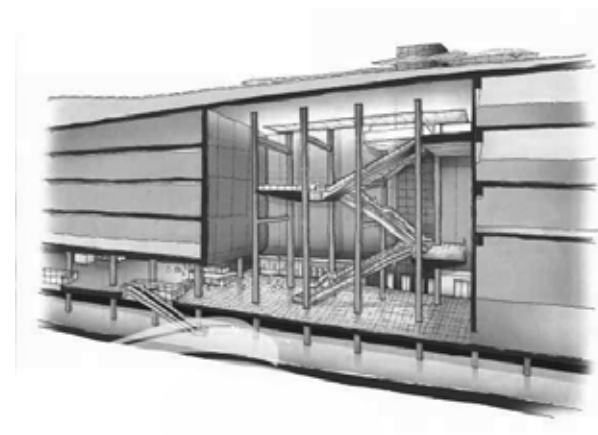

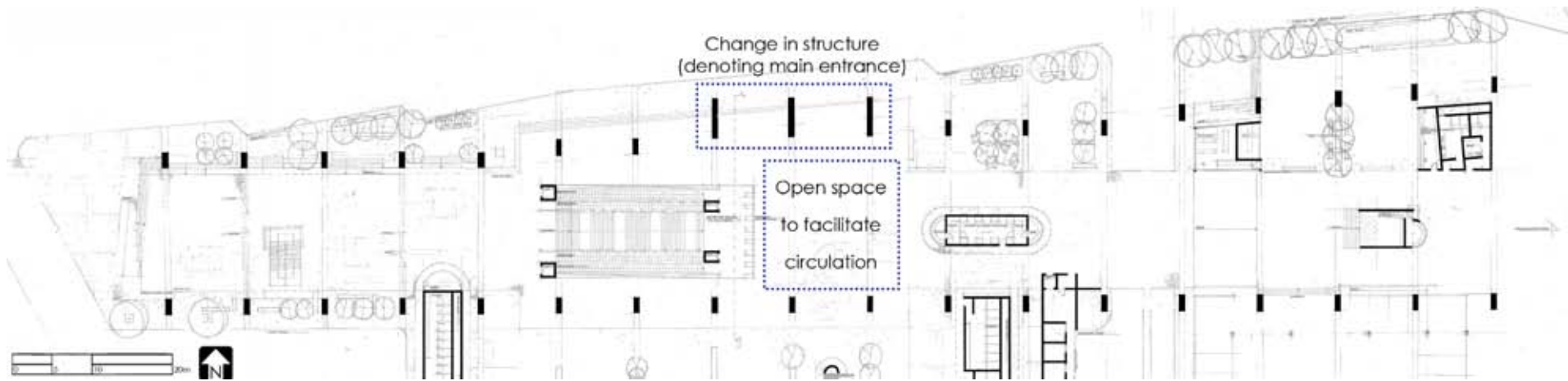

4.2 SANDTON CONVENTION CENTRE

The Sandton Convention Centre is an example of a public building and platform able to cater for various events. The building is unique and different from other convention centres due to the manner in which the centre is spread and layered over several floors instead of one large area. The building is well integrated with the Sandton area; it is connected to Sandton City and is accessible from the street, in close range of many hotels and offices.

The facades of the building are designed in a form-follows-function manner. "Air grilles are air grilles, vertical strips in the facade are stairs towers and blank walls are blank walls" (Rasmuss, 2001: 20). It is a building with little pretence and everything is what it seems.

The front door and street entrance of the building is given its due importance with large but simple canopies. The entrance is large, visibly open and transparent; a true public entrance.

The building interior is open, functional and designed with minimal clutter. The architects and interior designers seem to have resisted the temptation to give the building a theme and this resulted in a restrained but simple and elegant landmark. The architecture and interior design work together seamlessly. Details are simple and understated, but remain interesting

Public building: Any structure used in whole or in part as a place of resort, assemblage, lodging, trade, traffic or occupancy by the public. (Berres, 2001).

LOCATION:

Johannesburg, South Africa

COMPLETION:

2000

PROGRAM:

Convention, exhibition and special event space

GROSS FLOOR AREA:

65 000 m²

ARCHITECTURAL TEAM:

Louis Karol Architects

ARCHITECTS:

Michael Scholes, Louis Karol, Yvonne Smuts

INTERIOR DESIGNER:

Julius & Company

ILLUS. 4.6: Design application of Sandton Convention Centre to the Platform Building at Menlyn. (Opposite)
 ILLUS. 4.7: Photo collage of Sandton Convention Centre including diagrammatic section. (Right)

throughout the building. This building is an example of a platform building that can be the backdrop of any event, but is an event in itself.

DESIGN APPLICATION

One of the focus areas of the design proposal will be the functional aspects of what a platform building should be. The Platform Building at Menlyn should act as a backdrop to emergent activities and an event in itself. The design details and material use of the Platform Building should be understated, yet interesting. The entrance of the building will be accentuated by an exception in the regular column-and-beam structure (illus. 4.6) which characterises the building. This break will establish a new rhythm and vast open space, making the building accessible from the street.

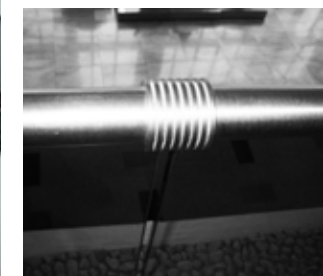
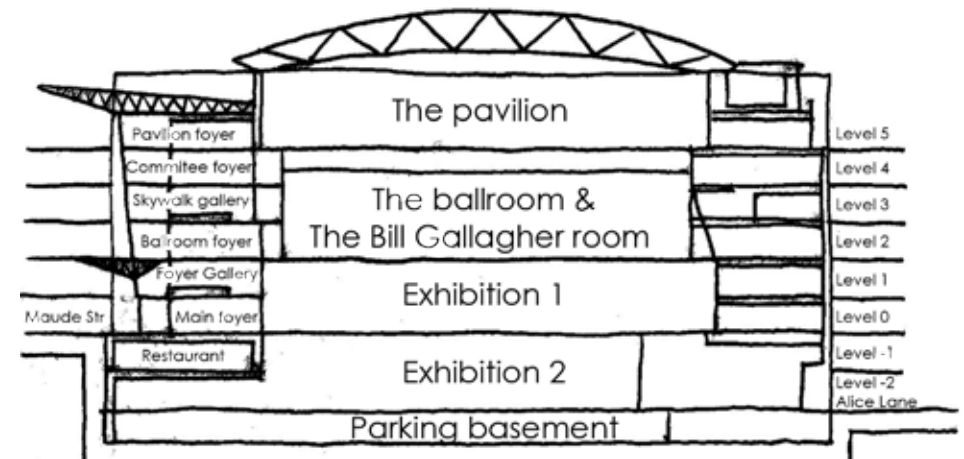
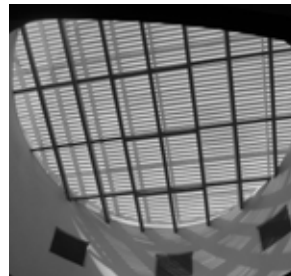

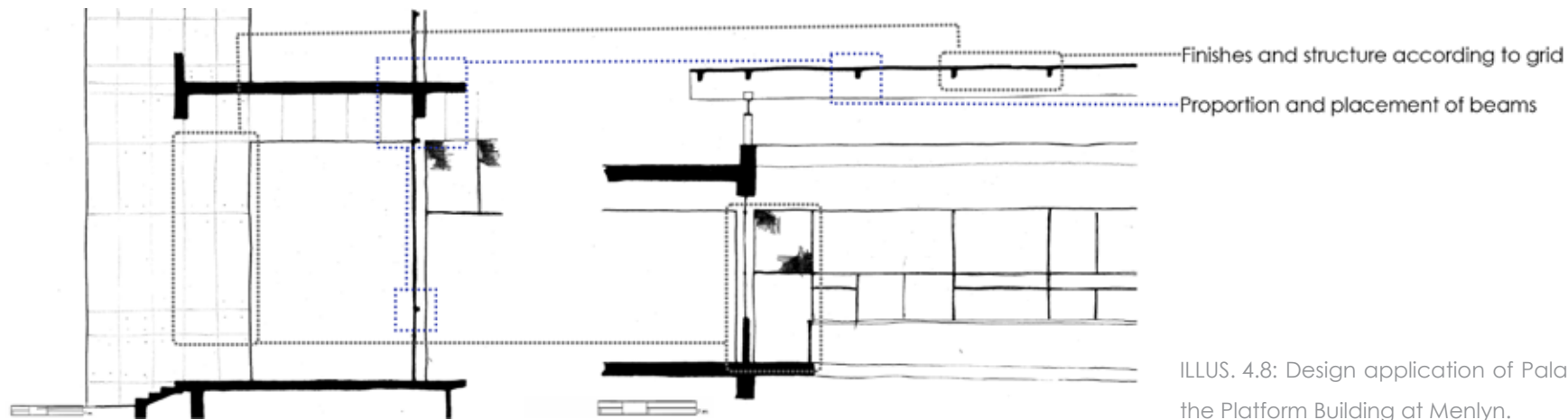

ILLUS. 4.8: Design application of Palais de Justice to the Platform Building at Menlyn.

4.3 PALAIS DE JUSTICE

The Palais de Justice in Nantes, France is an example of fractal theory in architecture. The building is used as a court of law and was designed to represent justice and power in the form of architecture. Ateliers Jean Nouvel tried to reflect the concept of justice and “fairness” throughout the entire design of the building.

Fractal geometry and design was thought to be an appropriate tool for conveying this concept. With the use of fractals, the same attention to detail could be given to all scales of the building; from the exterior, to the façade and to the interior. All scales are addressed in the same manner, symbolising equality across all income groups, races and classes. All scales and thus ‘all people’ are treated equally.

In design, fractals are applied at all levels, from the design grid through to signage. The use of highly reflective and polished surfaces, seemingly extends the dimensionality of the interior space. A sensation of the fourth dimension, time, is felt when one is suspended between the ceiling and its mirror reflection beneath one's feet.

While it is debatable that fractal principles embody the building's essence, the architectural experience as a whole evokes feelings of power and justice. The fractality of the project makes the building legible and tangible as a whole. The application of fractals at all levels is truly experienced and renders the building interesting and less intimidating despite its massive scale.

LOCATION:

Nantes, France

COMPLETION:

2000

PROGRAM:

Law court including crown court, magistrates' court and criminal court

GROSS FLOOR AREA:

20 000 m²

ARCHITECTURAL TEAM:

Ateliers Jean Nouvel

ARCHITECTS:

Jean Pierre Bouanha, Anne Favry, Hafid Rakem, Gaston Tolila

ILLUS. 4.9: Photo collage of Palais de Justice, including ground floor plan.

DESIGN PRINCIPLES

The application of fractals and self-similarity to the Platform Building at Menlyn could contribute to the legibility and experience of the building as a whole. Fractals will not be applied to the same extent as at the Palais de Justice. It is believed that a level of self-similarity will aid in rendering the large structure of the Platform Building at Menlyn less intimidating and more inviting to the human scale.

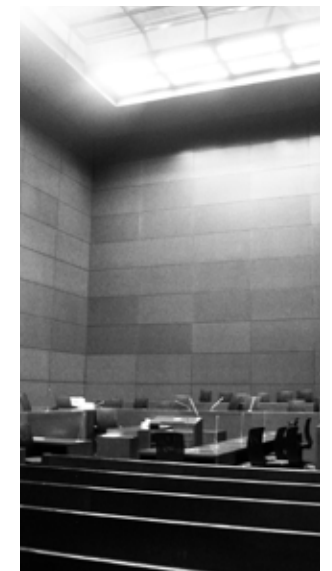
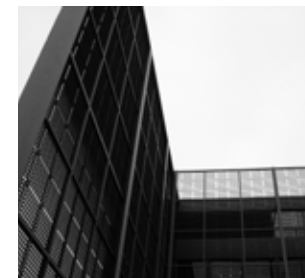
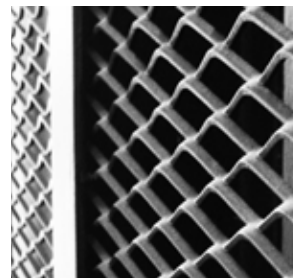
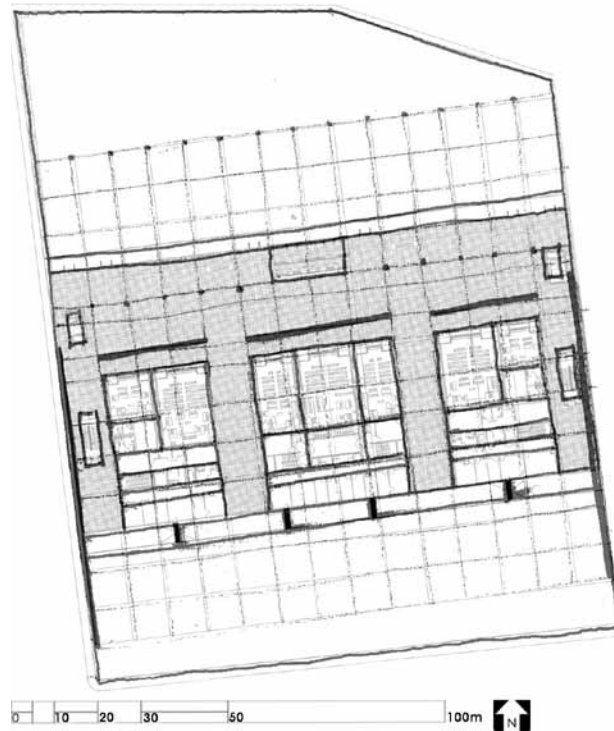

CHAPTER 5

URBAN FRAMEWORK

The purpose of an urban framework is to outline the vision and development principles for an area. It guides and informs development in order to achieve a unified vision and goal for the area.

The New Menlyn Node framework was developed through documentation (illus. 5.11 on page 42) of the existing conditions in the area, observation of successful public spaces and the consultation of existing frameworks in the vicinity.

5.1 MENLYN NODE ANALYSIS

The following aspects of the Menlyn Node are analysed and documented:

- Current land use
- Green structure
- Existing vehicular movement

KEY

Mixed use
Business
Educational
Commercial
Residential



ILLUS. 5.1: Current land use of Menlyn node.

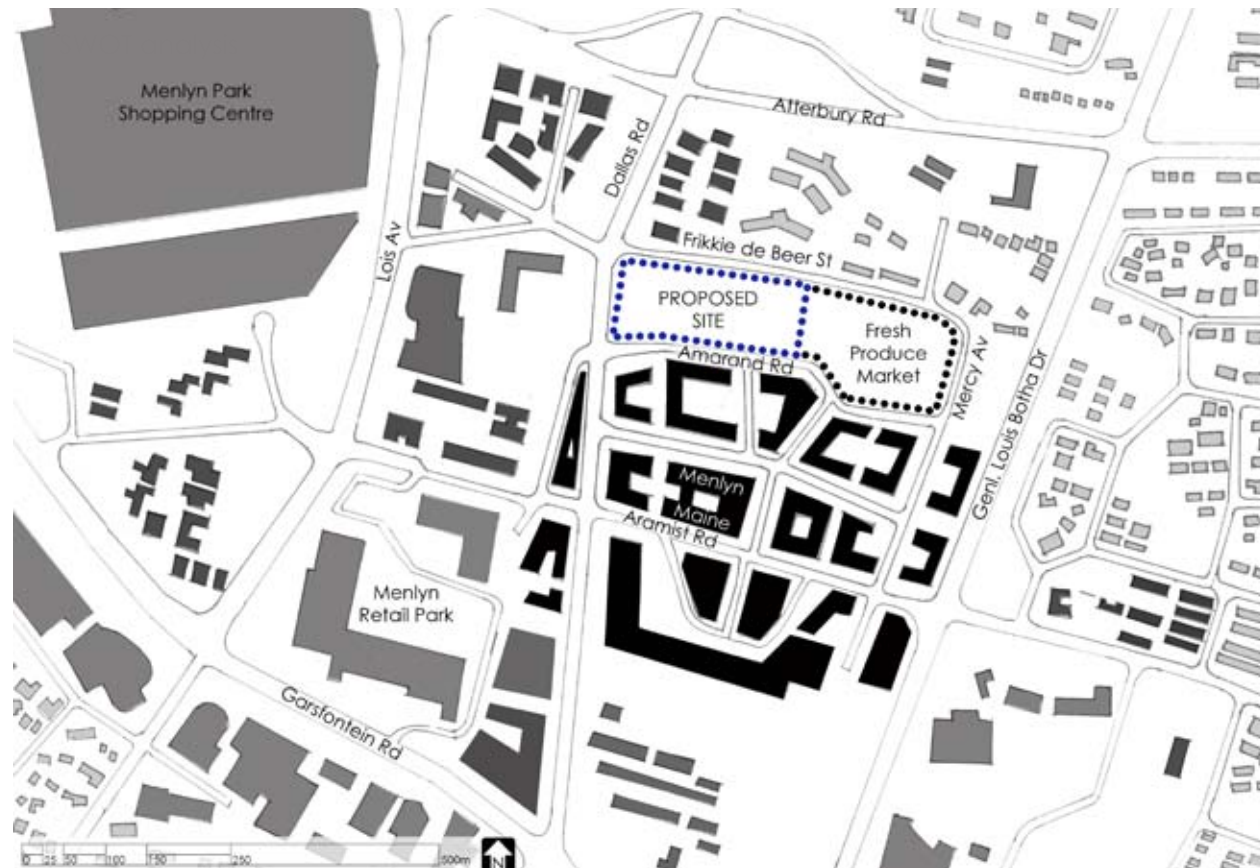



ILLUS. 5.2: Menlyn square as example of commercial use. (Far left)



ILLUS. 5.3: Old Mutual Office Park as example of business use. (2nd from left)

ILLUS. 5.4: Damelin College as example of educational use. (2nd from right)

ILLUS. 5.5: Litter in Menlyn node. (Far right)

ILLUS. 5.6: Green structure of Menlyn node. (Below)

KEY

- Open Green Spaces
- Abandoned Green Spaces
- Moreleta Spruit
- Existing Trees



5.1.1 CURRENT LAND USE

The node is currently focussed on commercial, business and educational use (illus. 5.2, 3 & 4 respectively). The Menlyn Maine development is mixed use (business, commercial and residential use). The area is entered for work and shopping on a daily basis. The surrounding low density residential neighbourhoods indicate that many people also travel from the area on a daily basis. There is thus a constant flow of traffic into and away from the area.

5.1.2 GREEN STRUCTURE

The Moreleta Spruit river runs across the Menlyn node, surrounded by open green spaces. Some of these green spaces are in a state of neglect, littered (illus. 5.5) and considered unsafe (City of Tshwane, 2007: 22), yet some are well used and maintained.

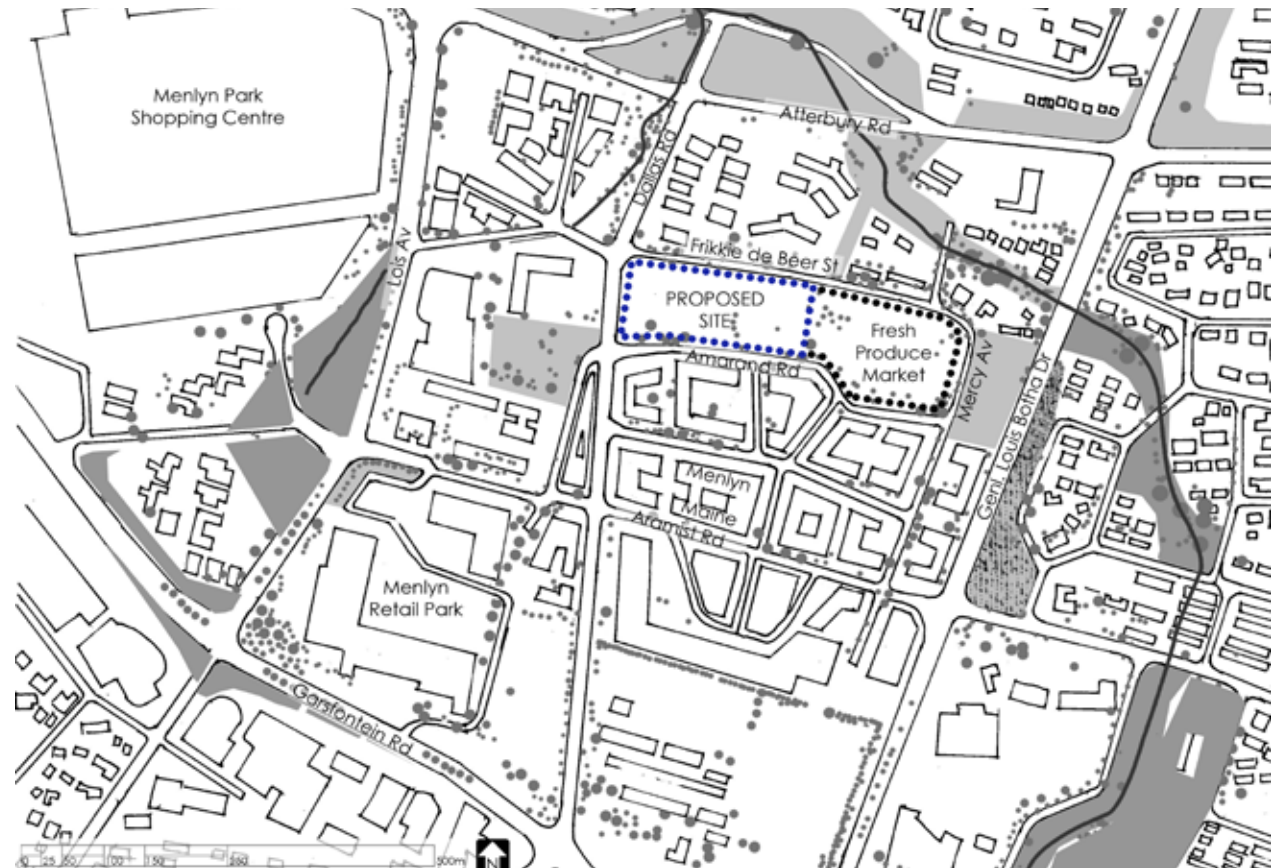

Pretoria CBD

Johannesburg (N1 Highway S)

Polokwane (N1 Highway N)

Emalahleni (N4 Highway)

KEY

Heavy Traffic

Medium Traffic

Light Traffic



ILLUS. 5.7: Vehicular movement in Menlyn node.



ILLUS. 5.8: Traffic congestion on Atterbury Road.

5.1.4 VEHICULAR MOVEMENT

The Menlyn node is not only a destination. It is also a place of transition between the Pretoria CBD, its suburbs and surrounding cities.

Poorly developed transport facilities, weak links to the rest of the city and traffic congestion threaten to choke the area (illus. 5.8). This could force development to migrate away from the region to less congested regions (City of Tshwane, 2007:26).



ILLUS. 5.9: Development in Menlyn node - 2010.

5.1.3 SWOT ANALYSIS

Strengths

- Large user base (±20 000 people per day)
- Mixed use zoning
- Development currently taking place (150 000m² in 2010; 425 000m² in 2020) (illus. 5.9-10)
- Ample green/open space

Weaknesses

- Low density
- Little/inefficient public transport infrastructure
- Introverted, disconnected public spaces
- Beggars are present in the area, especially at the large intersections
- Pedestrian unfriendly



ILLUS. 5.10: Development in Menlyn node - 2020.

Opportunities

- Increase density
- Provide public transport infrastructure
- Create outside public spaces
- Connect public spaces
- Create upliftment opportunities
- Use abandoned spaces for productive landscape
- Create pedestrian friendly infrastructure

Threats

- Crime
- Boundaries (arterial roads) difficult to bridge
- Taxi industry might not adhere to new transport infrastructure

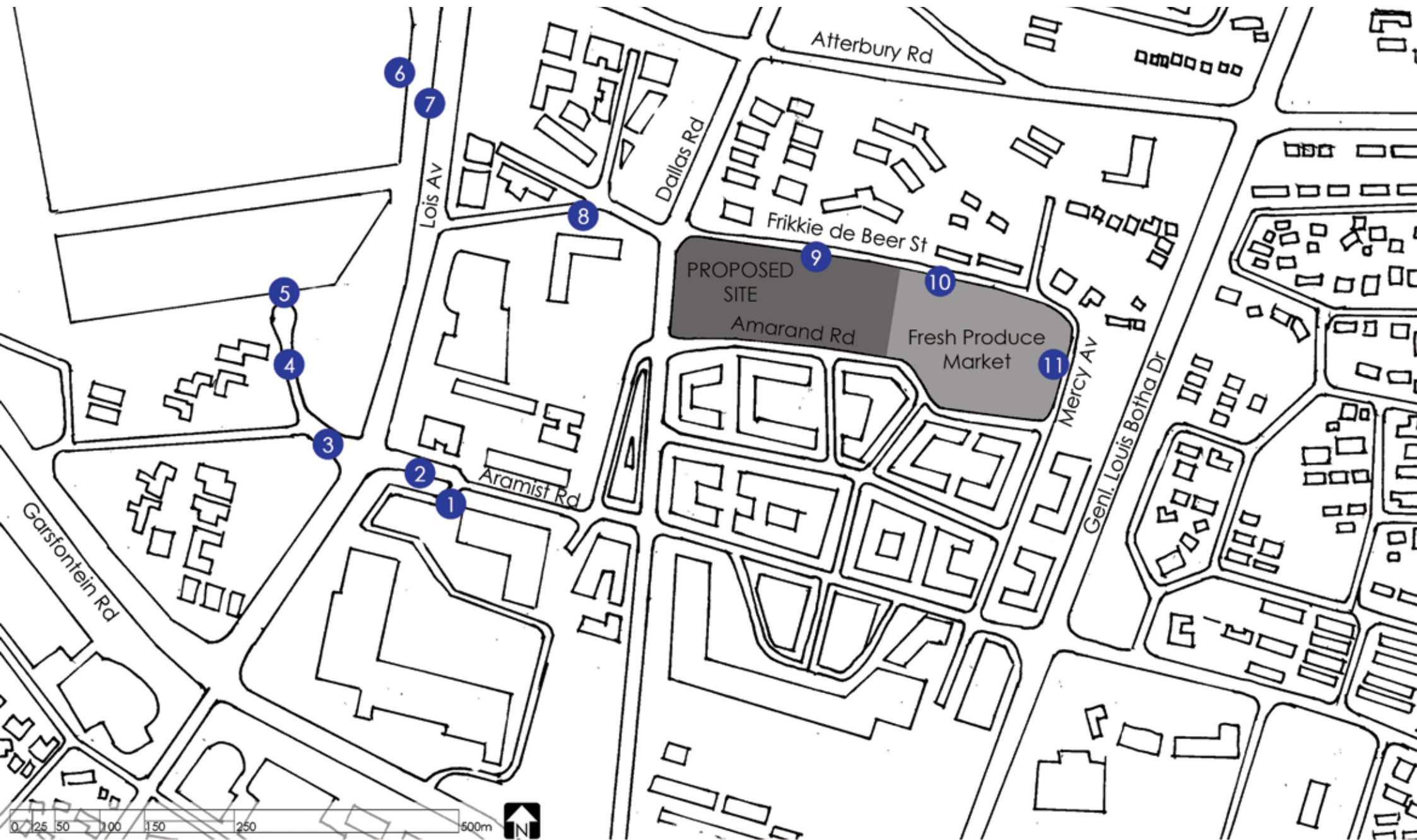

ILLUS. 5.11: Visual context of precinct.



5.2 EXISTING FRAMEWORKS

Currently, a number of frameworks relevant to the Menlyn node exist. The frameworks, relevant to the NEW MENLYN NODE FRAMEWORK will be discussed in this section. The frameworks are:

- Tshwane Regional Spatial Development Framework: Eastern Region (TRSDF)
- Menlyn Node Urban Development Framework (MNUDF)
- Menlyn Node Spatial Development Framework (MNSDF)

The frameworks listed below were also taken into account for the NEW MENLYN NODE FRAMEWORK. For the sake of brevity they are not discussed here because they are less relevant:

- Metropolitan Spatial Development Framework

- Pretoria East Mobility Study
- Tshwane Open Space Framework

5.2.1 TSHWANE REGIONAL SPATIAL DEVELOPMENT FRAMEWORK: EASTERN REGION (TRSDF)

The TRSDF makes use of the principles laid out by the *Tsošološo* programme (Quality Public Spaces Programme). This programme encourages investment in nodal areas, activity spines and intermodal transport exchanges. This investment takes place in the form of public, squares and markets, pedestrian walkways, public transport routes and stops, public art and green structure (Illus. 5.6 on page 39).

The TRSDF is in favour of nodal development over and above linear development as

“energy potential contained in lines of movement is released through stopping, not through movement” (City of Tshwane, 2007: 39). The Menlyn node is identified as a major metropolitan node that should be developed into an area with mixed land uses surrounded by high density housing. The framework takes the different movement systems of Tshwane into account and states that “new large-scale development initiatives should be planned around the public transportation facilities” (City of Tshwane, 2007:17).

The NEW MENLYN NODE FRAMEWORK regards the following aspects as relevant:

- Development should take place around public transport facilities in the form of TOD.
- Development should take place in nodal areas and along activity spines.

KEY

- 1 Town square
- 2 Public square and community facility
- 3 Green zone and pedestrian walkway
- 4 Activity spine
- 5 Significant intersections



ILLUS. 5.12: Tsošološo programme principles applied to NEW MENLYN NODE FRAMEWORK.

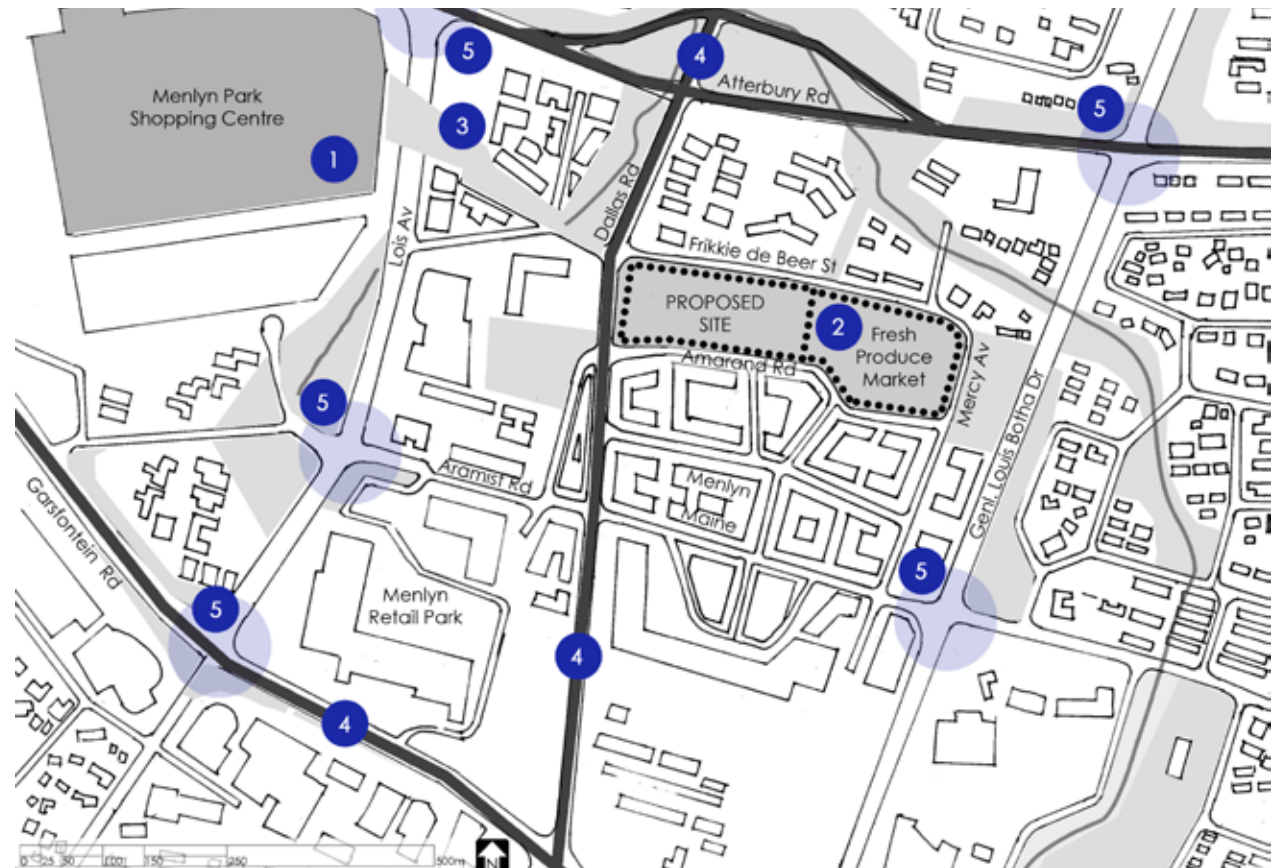

5.2.2 MENLYN NODE URBAN DEVELOPMENT FRAMEWORK (MNUDF)

The MNUDF proposes the following development objectives relevant to the NEW MENLYN NODE FRAMEWORK and the Gautrain Platform Building at Menlyn:

- Upgrade and maintain the movement network to facilitate the efficient movement of various modes of transport within the Menlyn node, other activity nodes in the City of Tshwane and Gauteng Province.
- To enhance public transport facilities, and services and provide for easy and safe pedestrian movement in and around the Menlyn node.
- To minimise horizontal expansion of economic activities into surrounding residential areas by increasing the density of the Menlyn node.

- To enhance the economic viability and sustainability of the public transport system in the area as a result of more people residing within walking distance from these facilities and services.
- Retain, protect, formalise and upgrade green spaces within the Menlyn Node. Public-private partnerships are encouraged.

5.2.3 MENLYN NODE SPATIAL DEVELOPMENT FRAMEWORK (MNSDF)

The MNSDF proposes the densification and development of the Menlyn node. The framework proposes detailed performance criteria pertaining to vegetation, site boundaries, stormwater run-off, delivery areas etc. Where appropriate, the criteria defined for the MNSPD are incorporated in the NEW MENLYN NODE FRAMEWORK.

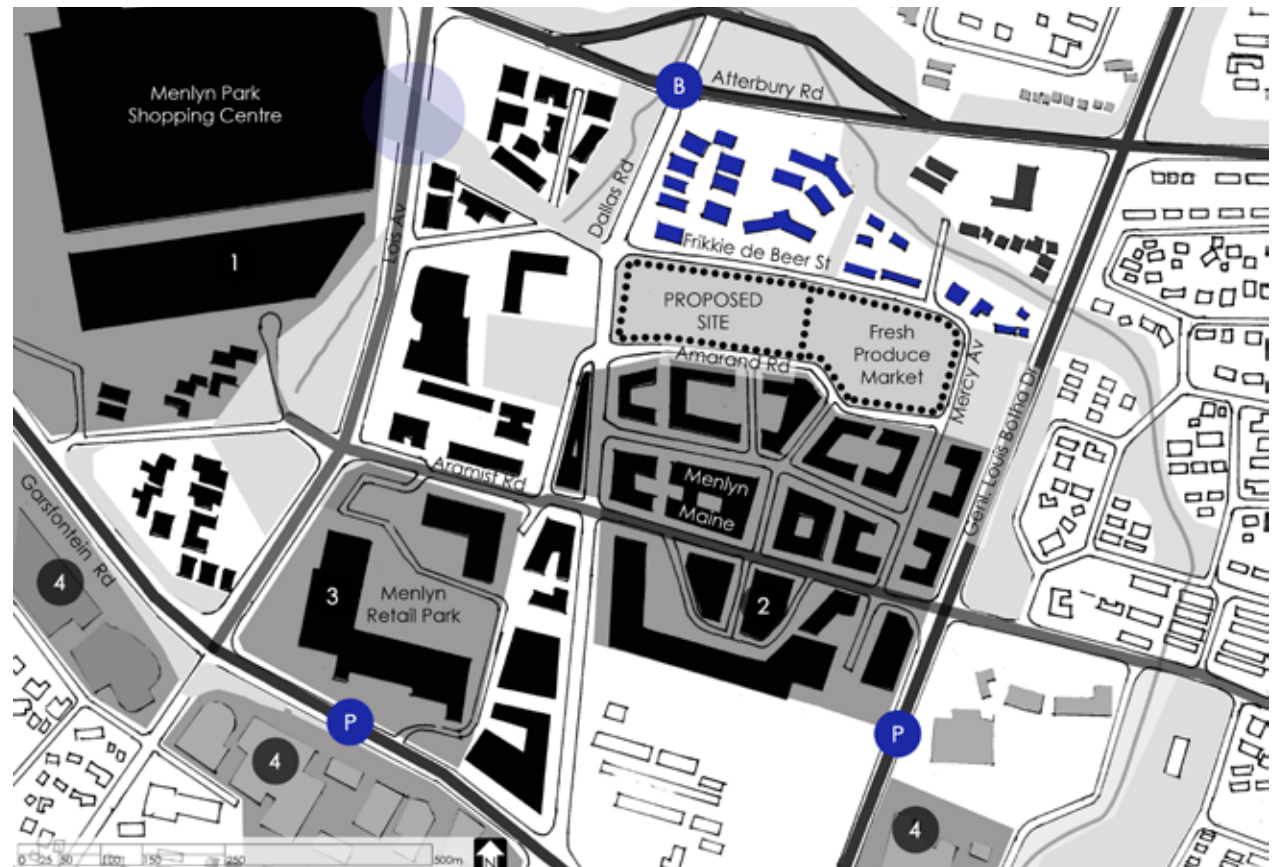
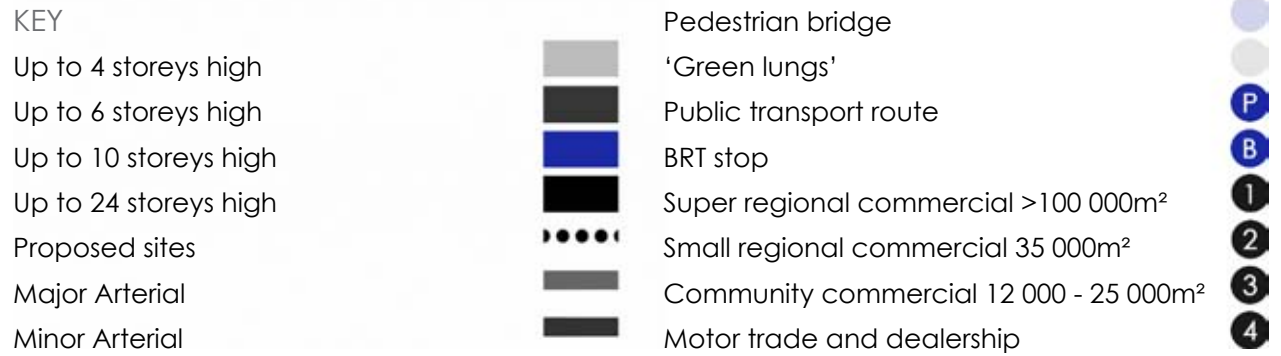

ILLUS. 5.13: Menlyn Node Urban Development Framework.

5.3 PROPOSED TRANSPORT FRAMEWORK

The various frameworks investigated strongly support the development of an intermodal transport exchange in the Menlyn node. The location of such an exchange will impact the transport routes of the area. The transport routes as proposed in the NEW MENLYN NODE FRAMEWORK are illustrated in illus. 5.14-18.

ILLUS. 5.14: Proposed underground Gautrain route.



ILLUS. 5.15: Proposed bus routes.

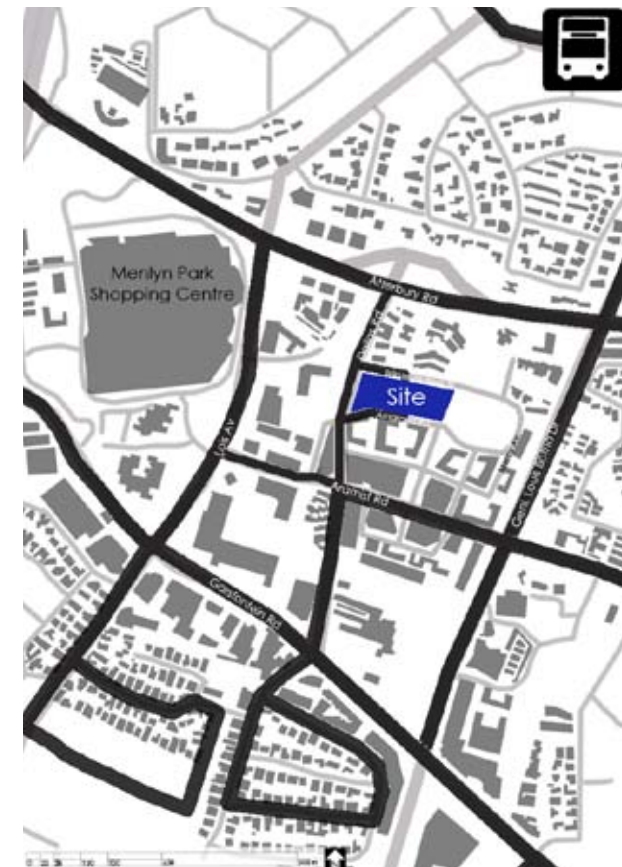

ILLUS. 5.16: Proposed taxi routes.



ILLUS. 5.17: Proposed motor vehicular routes.



ILLUS. 5.18: Proposed pedestrian routes.



5.4 DESIGN PRINCIPLES APPLIED TO NEW MENLYN NODE FRAMEWORK

The similarities of pedestrian boulevards and passages in shopping malls may be discerned by comparing and contrasting illus. 5.19 and 5.20. In illus. 5.21, the similarity between the framework layout at the smaller scale of a mall passage is likened to that of the larger scale small world network existing between itself and the proposed intermodal transport exchange. In illus. 5.22-23 the more formal event space is juxtaposed against the less defined public square. The NEW MENLYN NODE FRAMEWORK takes into account the popularity of malls and merges it with the existing development guidelines for Dallas, Frikkie de Beer and Aramist Streets.

ILLUS. 5.19: Plan and section of a typical pedestrian boulevard.

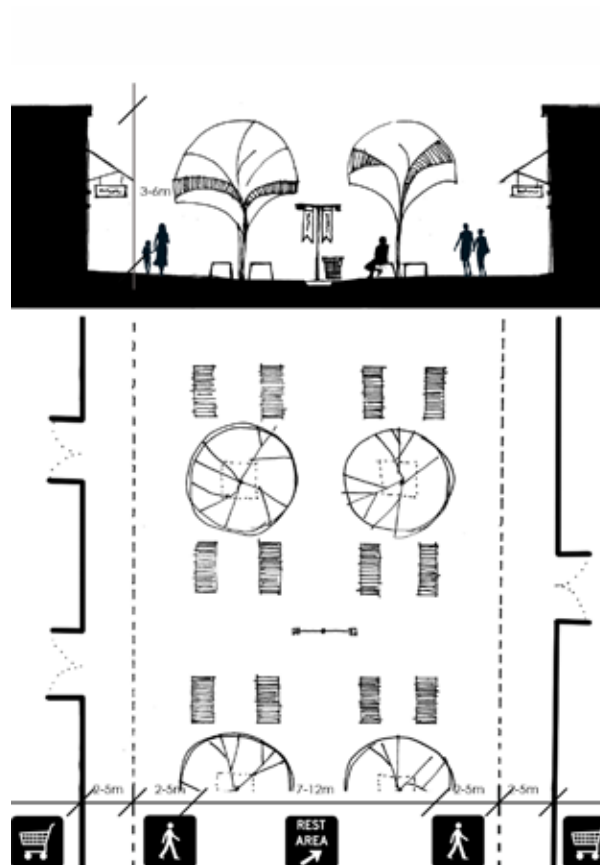

ILLUS. 5.20: Plan and section of a typical mall passage.

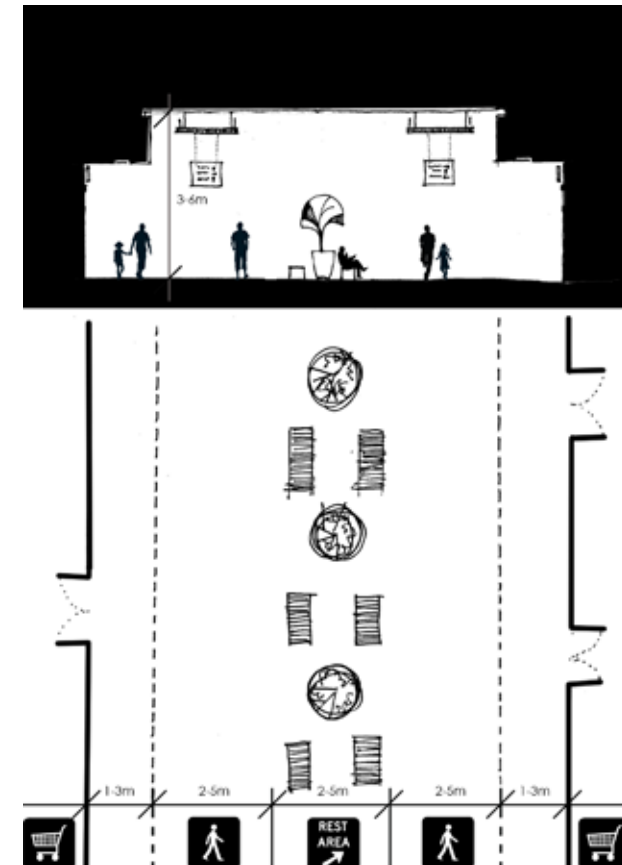

ILLUS. 5.21: Comparison of mall and framework layout.

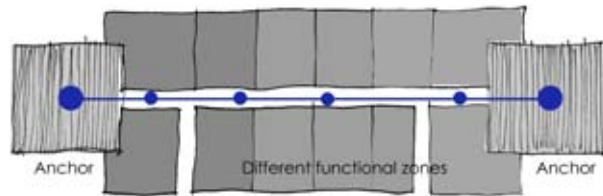

ILLUS. 5.22: Plan and section of event space.

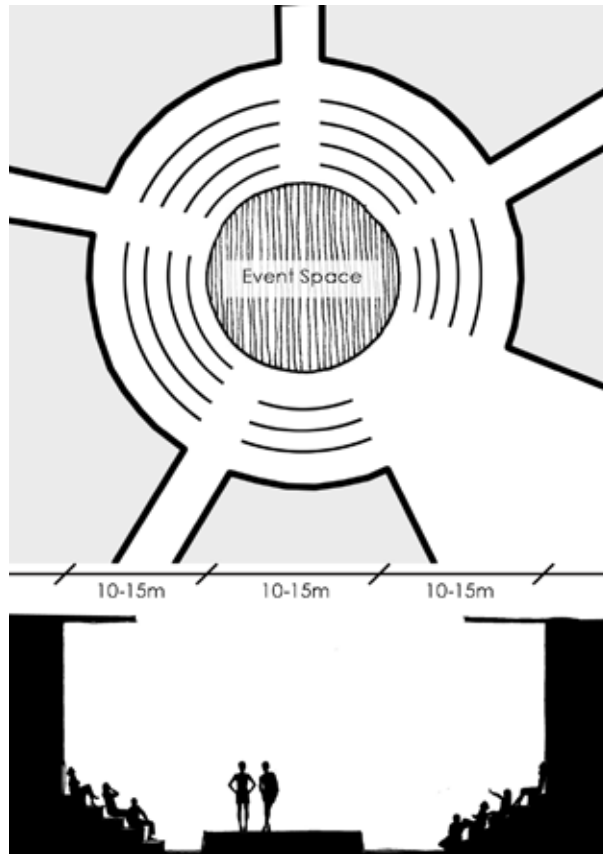

ILLUS. 5.23: Plan and section of public square as event space.

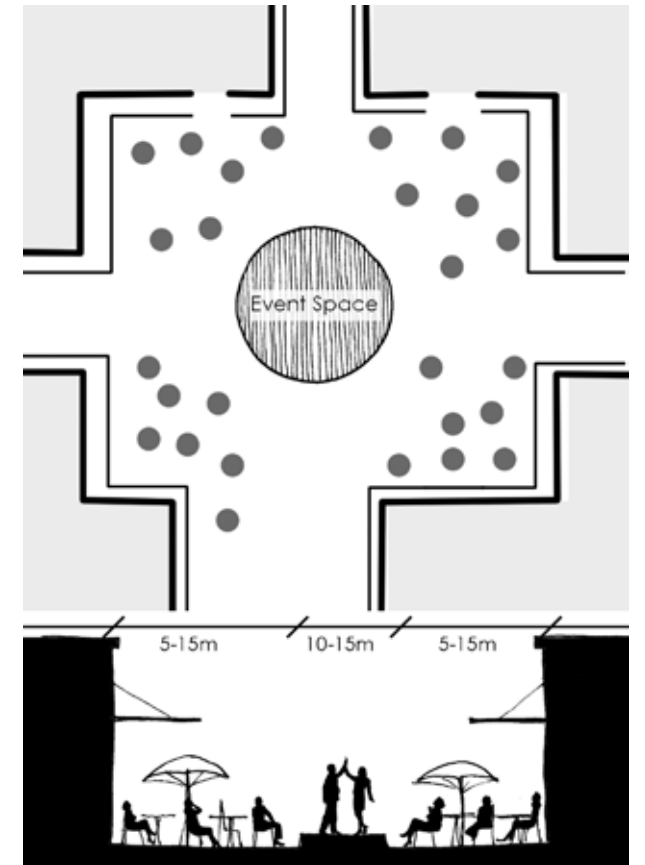

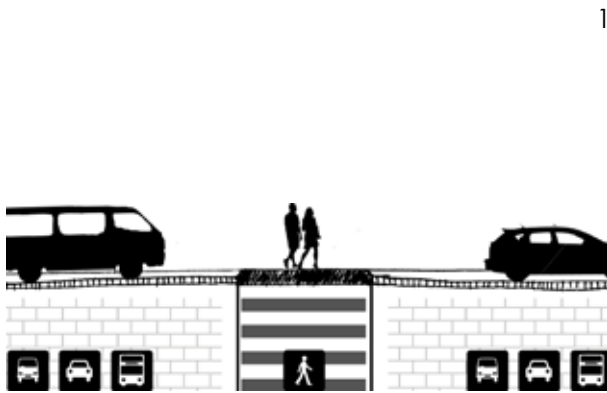

ILLUS. 5.24: Pedestrian crossing Genl. Louis Botha Drive.

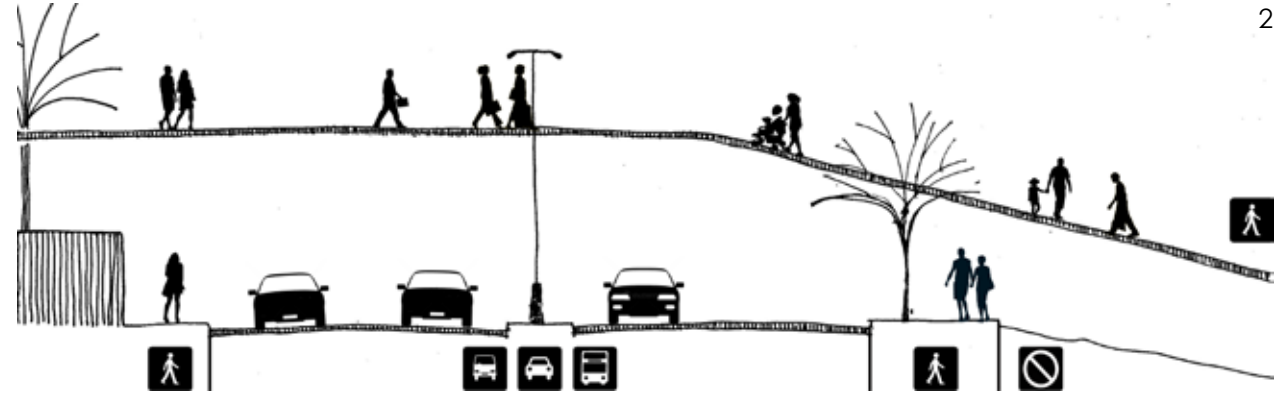

ILLUS. 5.25: Pedestrian bridge at Lois Avenue.

5.5 NEW MENLYN NODE FRAMEWORK

The NEW MENLYN NODE FRAMEWORK (illus. 5.28) represents a refinement of the existing area frameworks. The main objective is to create a node that is integrated with the larger Tshwane. However, the proposed framework should not compete with the Pretoria CBD, but should rather strengthen the connection of the Menlyn node with the CBD, the rest of Tshwane and Gauteng.

The framework aims to:

- improve the accessibility of the Menlyn node for both vehicular and pedestrian traffic. A pedestrian walkway will be created between the proposed site and Menlyn Park Shopping Centre. An improved pedestrian crossing at Genl. Louis Botha

ILLUS. 5.26: Section of Dallas Road. (Below)

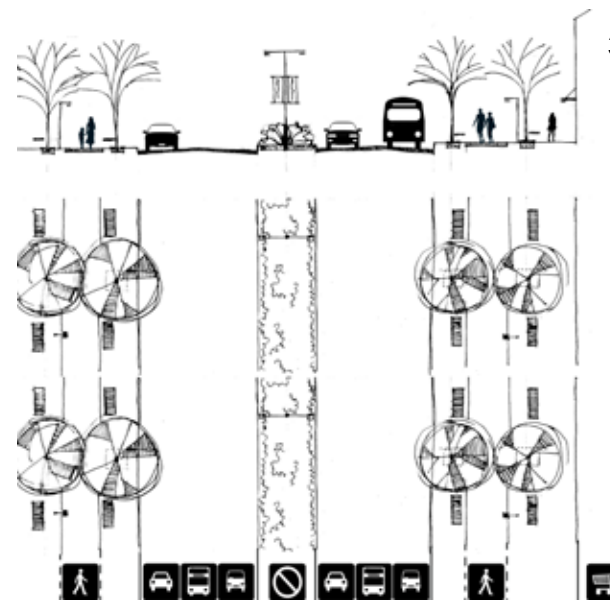

ILLUS. 5.27: Section of Frikkie de Beer Street and Amarand Road. (Below)

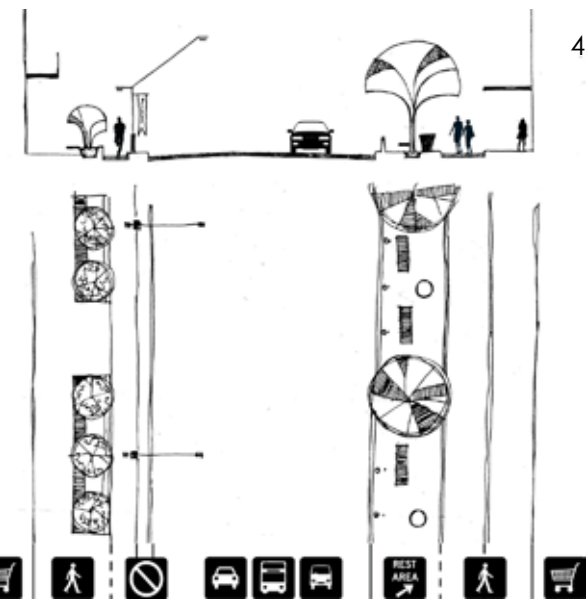

ILLUS. 5.28: NEW MENLYN NODE FRAMEWORK.

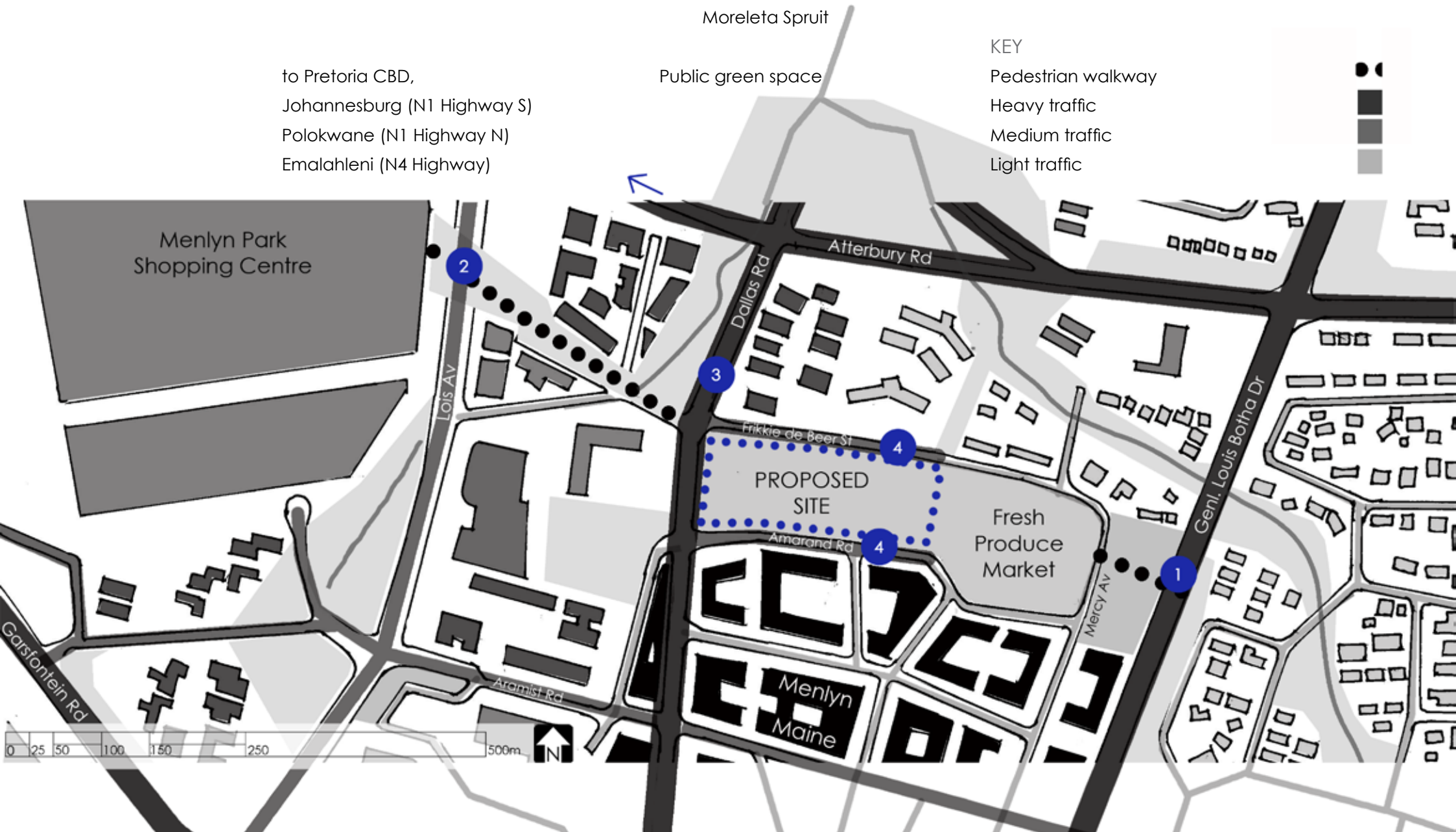

Drive will connect the Menlyn precinct with surrounding suburbs (illus. 5.24) and a pedestrian bridge at Lois Avenue should separate pedestrian and vehicular traffic (illus. 5.25).

- develop the node as an identity within Tshwane by implementing uniform street edges throughout the area (illus. 5.26-27)
- take pressure off the urban sprawl by increasing the density of the area and increasing development heights (illus. 5.29).
- extend its accessibility by reworking bus routes and introducing the Gautrain station to the precinct (illus. 5.30).
- emphasise the role of the Menlyn node as a destination rather than focussing on its transitional capacity (illus. 5.30).

ILLUS. 5.29: Proposed precinct development heights.
(Below)

ILLUS. 5.30: Precinct plan. (Opposite)

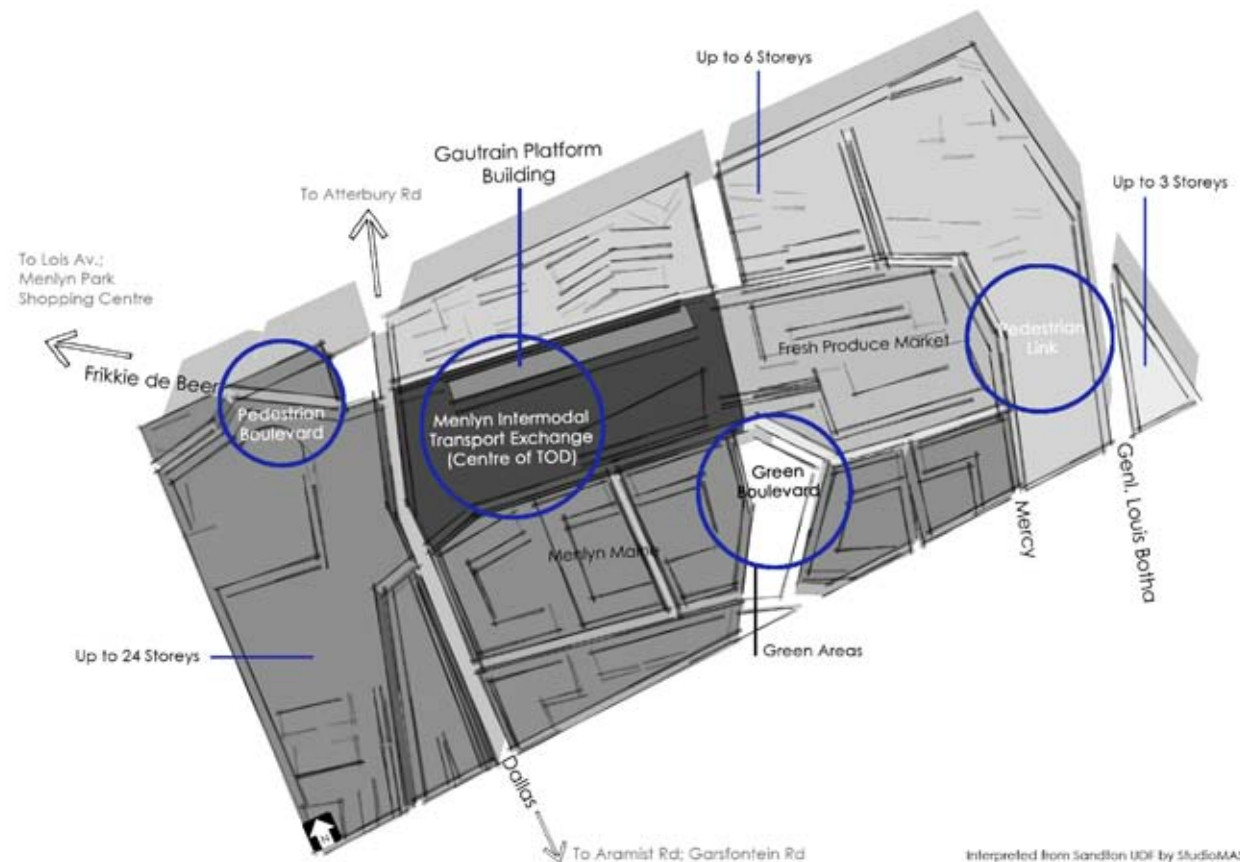

Interpreted from Sandton UDF by StudioMAS

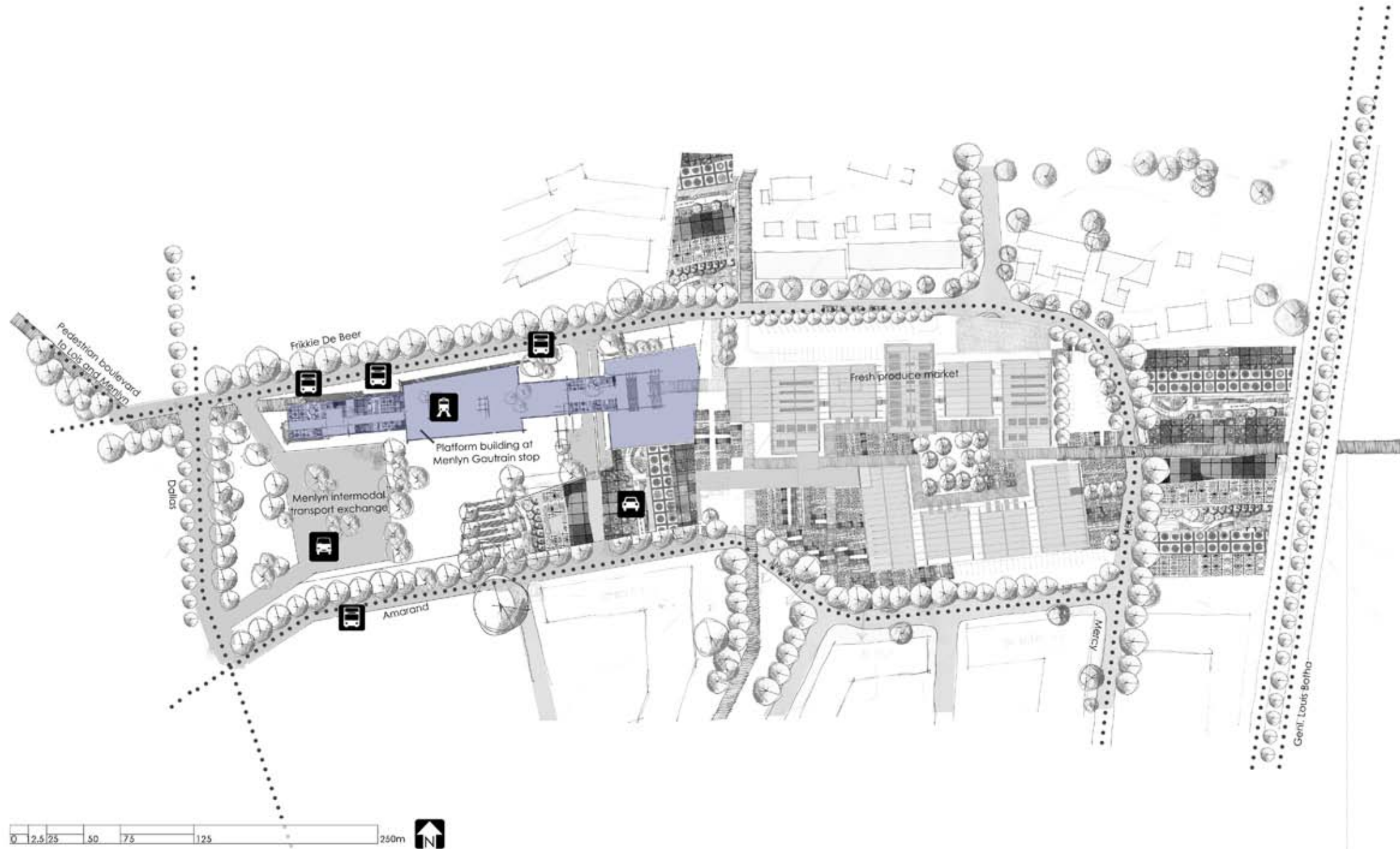

CHAPTER 6

DESIGN DEVELOPMENT

This dissertation intends to reinforce the Menlyn precinct as an important node within Tshwane as well as to contribute toward a more cohesive and integrated public transport system throughout Gauteng. The addition of a transport node at Menlyn could add a new node (and link) to the small-world network that forms the current transport system and contribute positively towards the experience and accessibility of the area.

The intention of the design is to create a platform for users to interact and to come into contact with different forms of public transport. The platform becomes a place for interaction, integration, transition and emergent activities.

The initial focus of the dissertation was the integration of different public transport modes.

A Menlyn Intermodal Transport Exchange was proposed as a project subject. The project scope later evolved into a Platform Building (with an underground Gautrain stop) at Menlyn, located within the Menlyn Intermodal Transport Exchange.

The design process and development will now be explained in a chronological order.

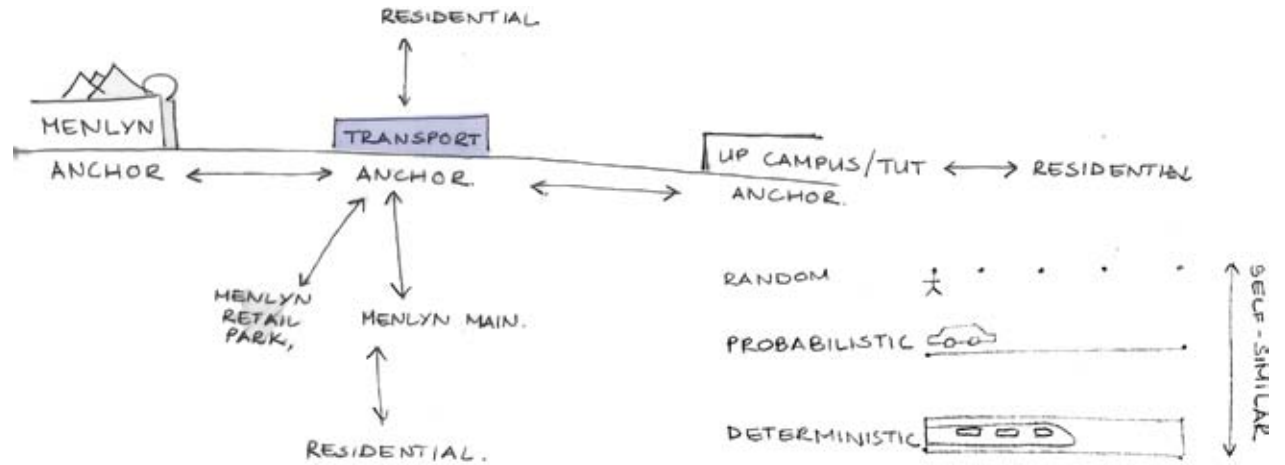

ILLUS. 6.1: Menlyn Intermodal Transport Exchange planning diagrams - April.

6.1 APRIL - FINAL PROJECT PROPOSAL AND CONCEPT

The Menlyn Intermodal Transport Exchange was proposed as a dissertation topic. The existing modes of transport were analysed and superimposed. The superposition and local transport was regarded as a chaotic system. Chaotic systems theory was investigated and led to the theory of fractals and small-world networks. The Menlyn Intermodal Transport Exchange was presented as a node within a small-world network.

Critique during design review:

- What is the relevance of fractals in architecture?
- Is the Menlyn area fractal/non-fractal?
- Should the transport interchange be one building or a series of smaller units around a node?

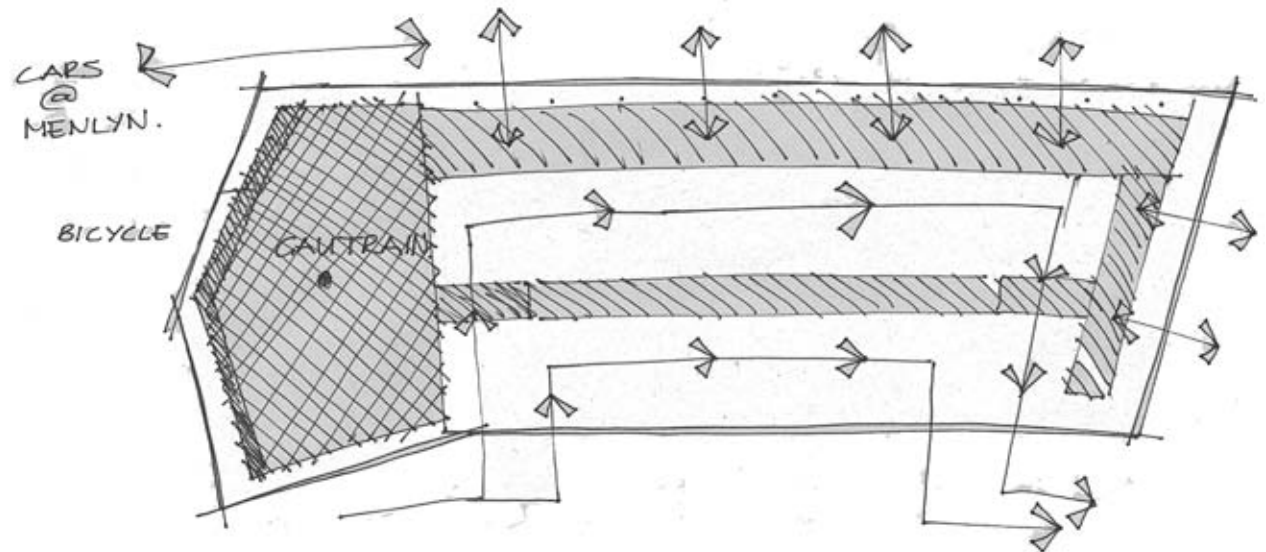
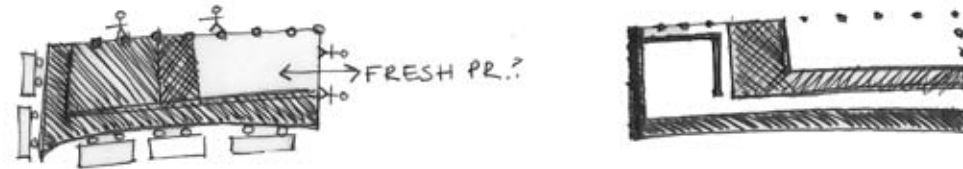

ILLUS. 6.2: Menlyn Intermodal Transport Exchange site plan diagrams - May.

6.2 MAY - CONCEPT DEVELOPMENT

The existing urban frameworks for Menlyn were investigated and an urban framework was proposed. Discussions with Mr. A. Wepener (a traffic engineer from BKS) addressed some of the functional aspects regarding an intermodal exchange. A site plan took shape and spaces for different modes of transport on site were identified.

Critique during design review:

- Why is it conducive to become more fractal?
- The connection between the different modes of transport is not visible on the site plan.
- The flows of different modes of transport should be better analysed and portrayed on plan.

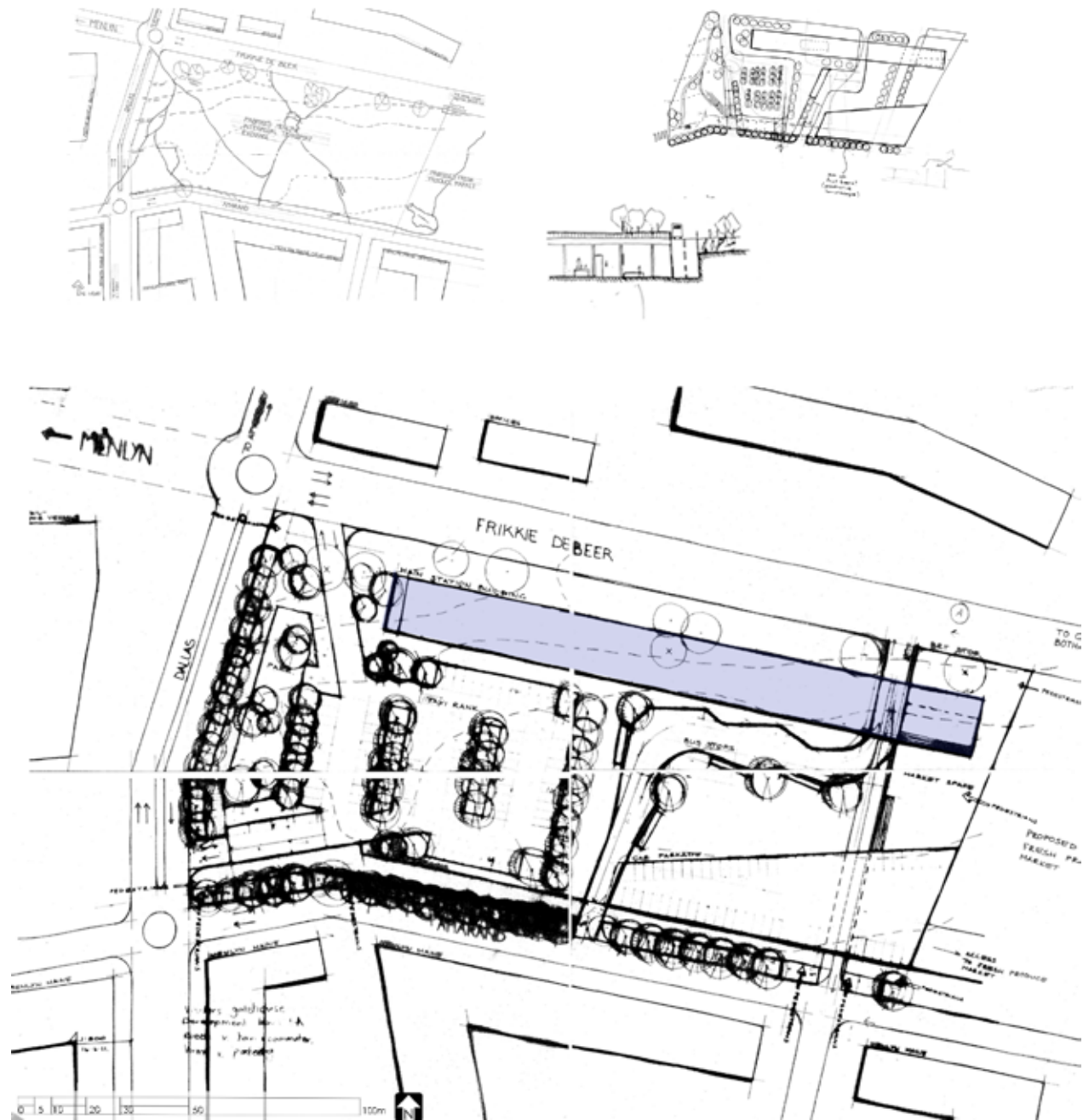

ILLUS. 6.3: Platform Building at Menlyn sketch plans and drawings - June.

6.3 JUNE - DESIGN (SKETCH PLAN STAGE)

The design of the intermodal transport exchange started to focus on one building. As the building concept evolved, it embraced and approached the concept of a platform building. The platform stretched between the different transport modes present at the transport interchange and the Gautrain entered this building from underground. The building became a blank canvas on which different activities of the transport exchange users could emerge.

Critique during design review:

- An intermodal transport exchange is too big a project for a dissertation.
- More integration should take place between different modes of transport.

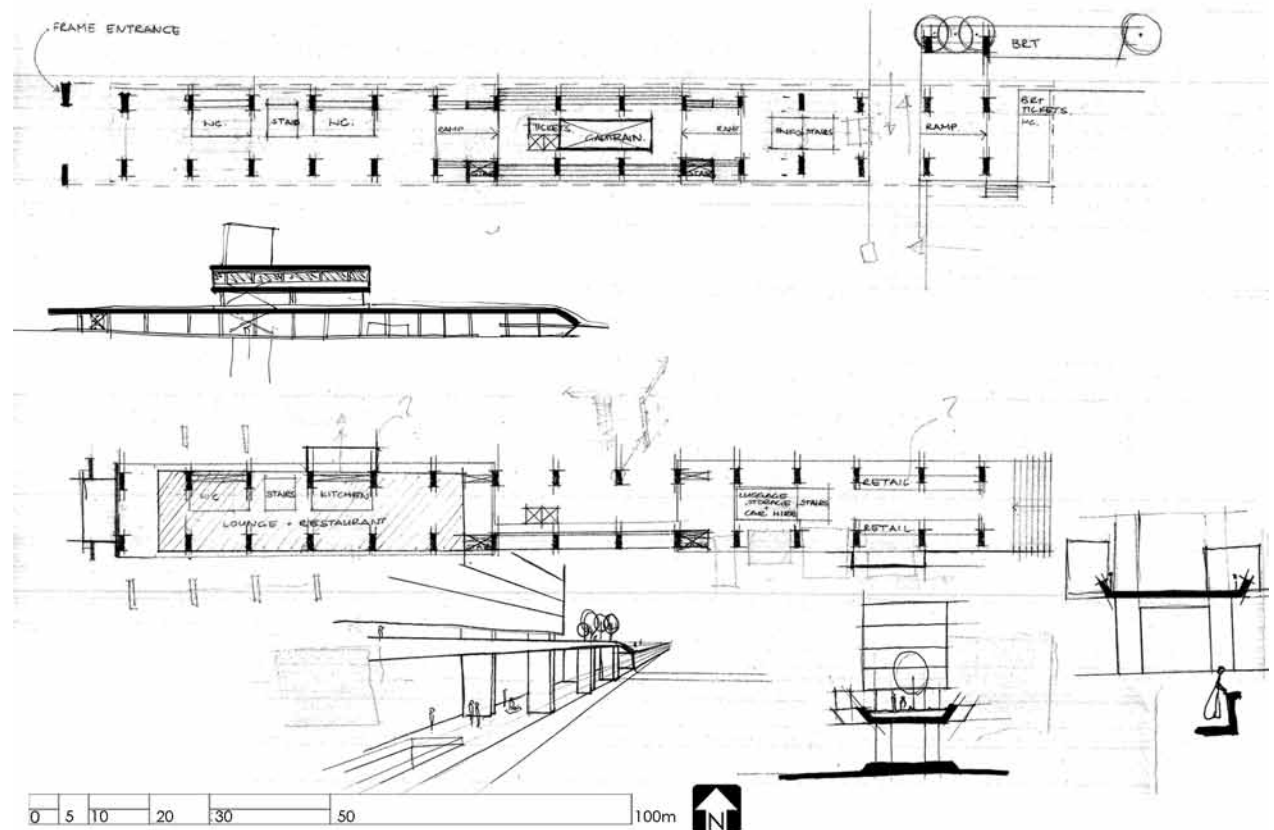
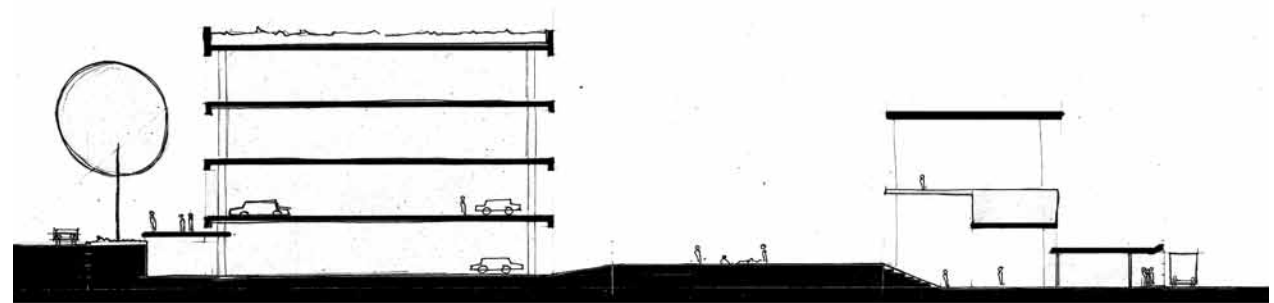

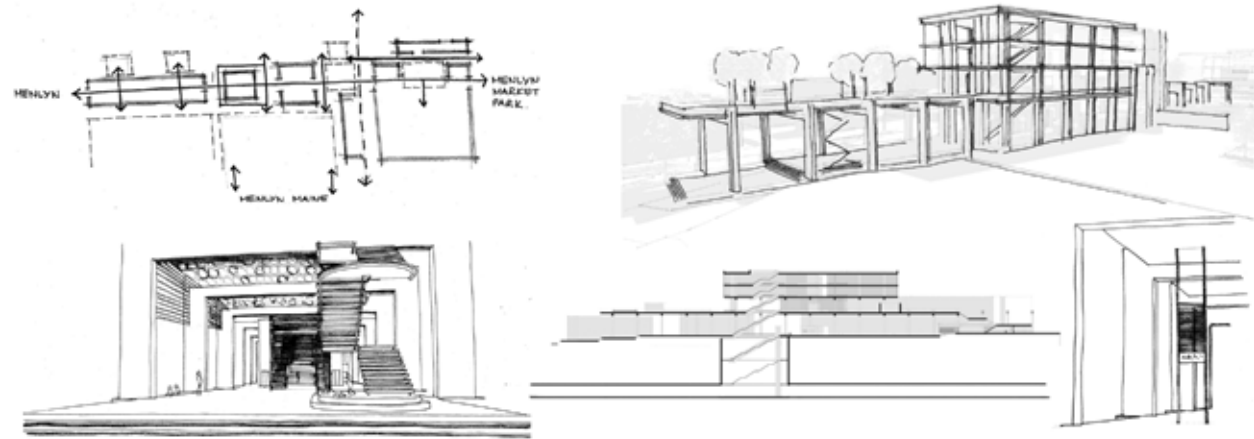

ILLUS. 6.4: Platform Building at Menlyn sketches, plans and drawings - July.

6.4 JULY - DESIGN (ADVANCED SKETCH PLAN STAGE)

The scope of the project was re-evaluated and all focus was turned on the development and design of the Platform Building. The building has an underground Gautrain stop and is located at the Menlyn Intermodal Transport Exchange. This building should serve as platform for users of different transport modes to integrate with the Gautrain. The parti diagram suggests a blank canvas with a continuous rhythm. This rhythm was implemented in the form of prominent column-and-beam structures at regular intervals.

Critique during design review:

- What is the reasoning behind the structure?
- What are the architectural concepts of the building?
- Indicate the different circulation routes.
- Should the roof or the column be most apparent?

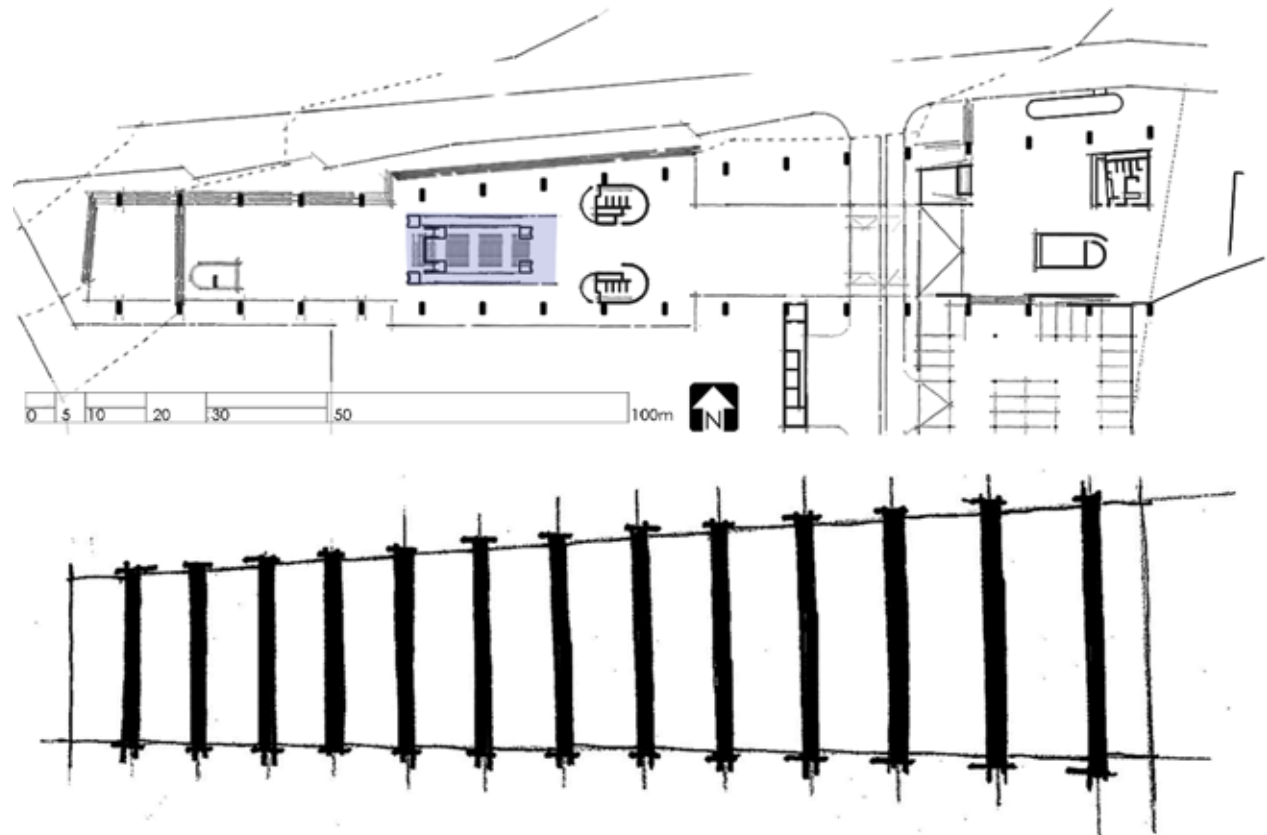

ILLUS. 6.5: Platform Building at Menlyn sketch section
- August.

6.5 AUGUST - TECHNICAL 1

The building as platform was investigated further. The structure was expressed as an important concept and prominent feature within the design. The different functions of the building were carefully placed as objects on the platform, separate from the structure. The entrance/exit of the Gautrain from below ground was accentuated with a skylight lending importance and function to the building.

Critique during design review:

- Ceiling heights should be reconsidered.
- How will users be protected from rain?
- How will temperature be controlled within the building?
- Skylight should be better resolved.
- How do the different systems within the building work?

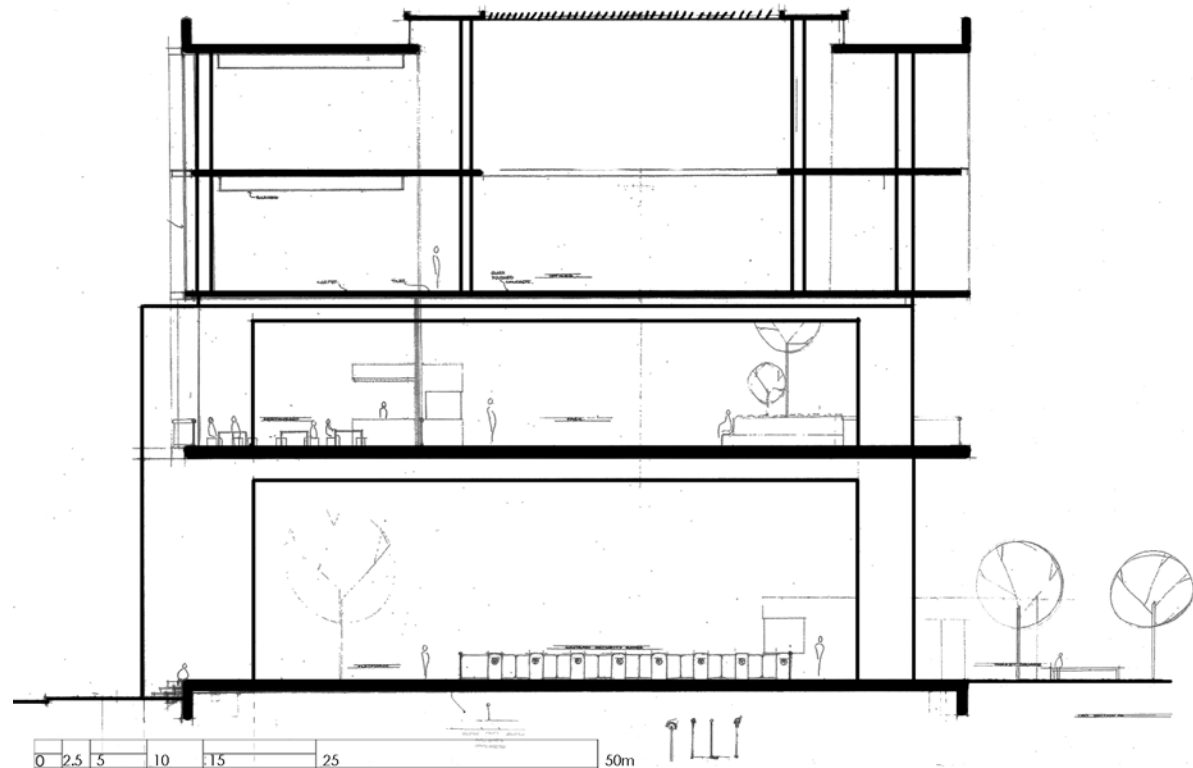

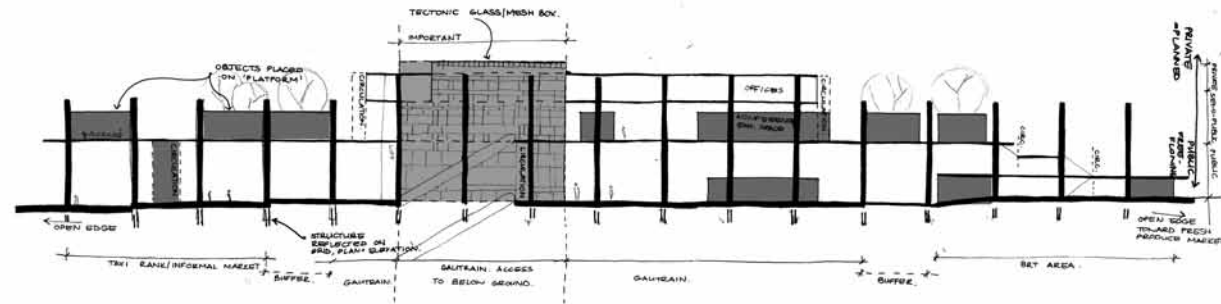

ILLUS. 6.6: Platform Building at Menlyn diagram, ground floor plan and first floor plan - September.

6.6 SEPTEMBER - TECHNICAL 2

The design presented was a further exploration of the platform. As the building moved from public on ground level to private on second level, the placement of 'objects on the platform' became more deliberate and dense. The importance of the Gautrain entrance/exit was accentuated with a mesh box-like structure that stretches up to roof level. This structure was divided by a grid pattern which transformed to a more human-scale as one progresses from public to private.

Critique during design review:

- How do sustainability issues influence the design?
- What is the theory behind the grid?
- How will the Gautrain corporate ID be incorporated into the project?
- Difficult to read interior and exterior spaces.

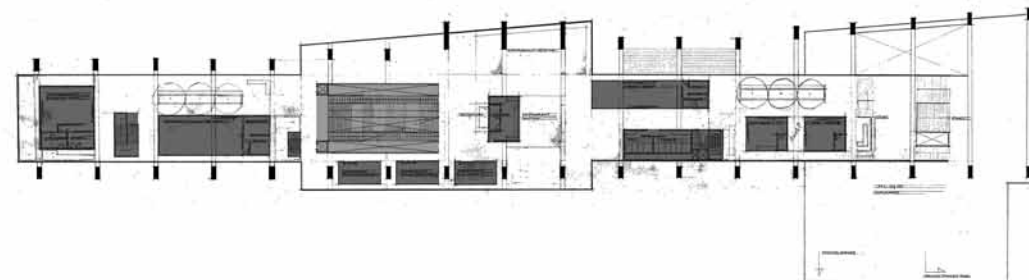
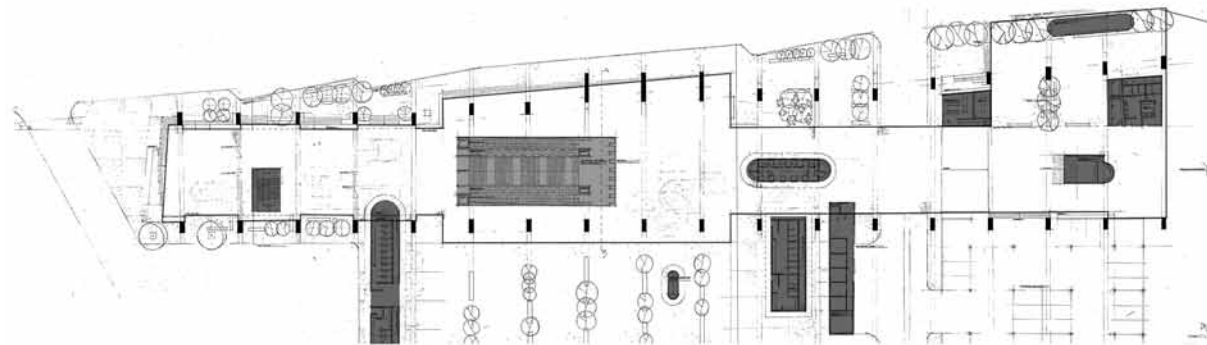

ILLUS. 6.7: Platform Building at Menlyn section - October.

6.7 DISCOVERIES AND NEW PERSPECTIVES

- The initial concept of integrating and connecting different modes of transport and their users with one another remains although the scope of the project has changed from an intermodal transport exchange to a Platform Building.
- The project focuses on creating a platform for different activities.
- There are particular functional issues that remain relevant to all projects.
- The route of different users of a building is paramount, but the design should allow for flexibility.
- The wish of any user of a building is to know that his/her needs and 'human'-scale was taken into consideration during the design process.

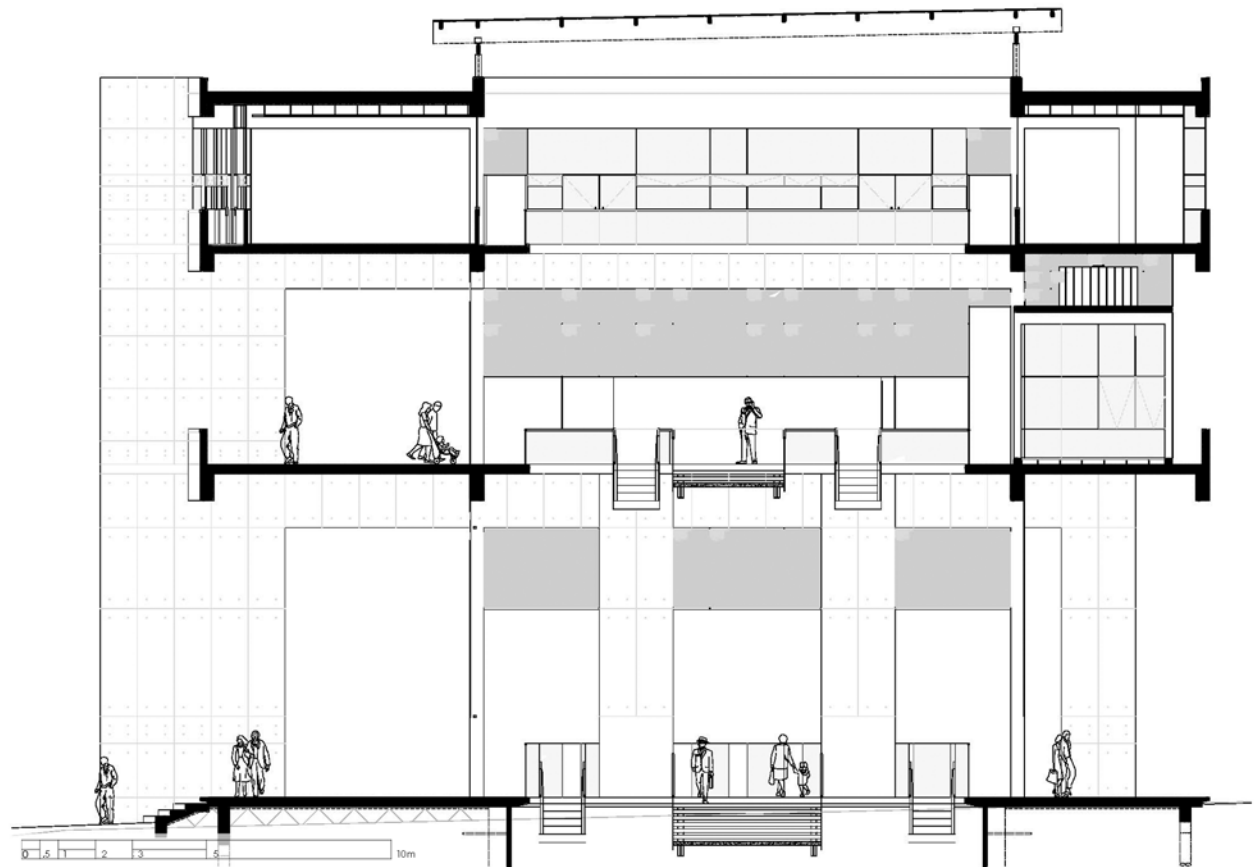

CHAPTER 7

DESIGN SOLUTION

The Platform Building (with an underground Gautrain station) at Menlyn promotes the integration of various public transport modes with the Gautrain (illus. 7.3). The description of the building as a 'platform building' could be interpreted as:

- an open, flat form on which different activities such as transition, waiting, eating, buying, selling, meeting, viewing etc. take place.
- a place, means, or opportunity for public expression of opinion.
- a formal declaration of principles, i.e. public transport should play an important role in the transport system.
- the threshold between the Gautrain and other modes of public transport.
- a point from which the public can access public transport.

The Platform Building at Menlyn includes conference/exhibition spaces and offices/facilities for the managers, staff and tenants of the Menlyn Intermodal Transport Exchange. These functions are separated by level as their nature changes from public to private (illus. 7.1).

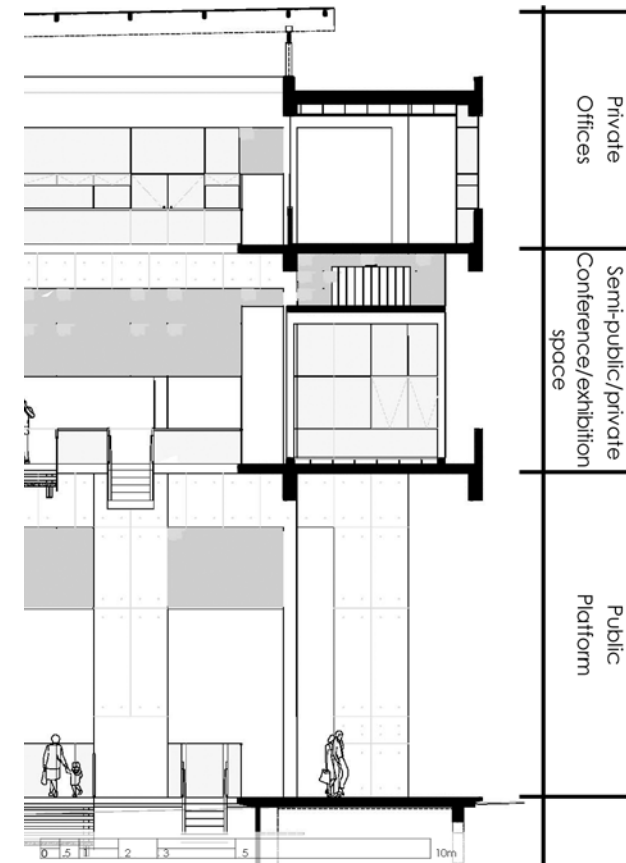

ILLUS. 7.1: Functions indicated per level.

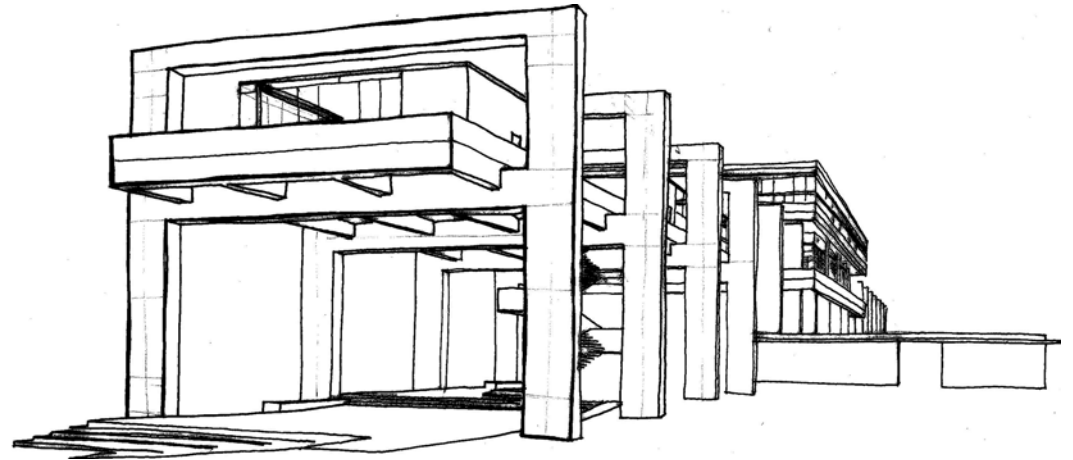

KEY

Bus stop

Taxi rank

Parking Garage

Entrance/exit to underground Gautrain station

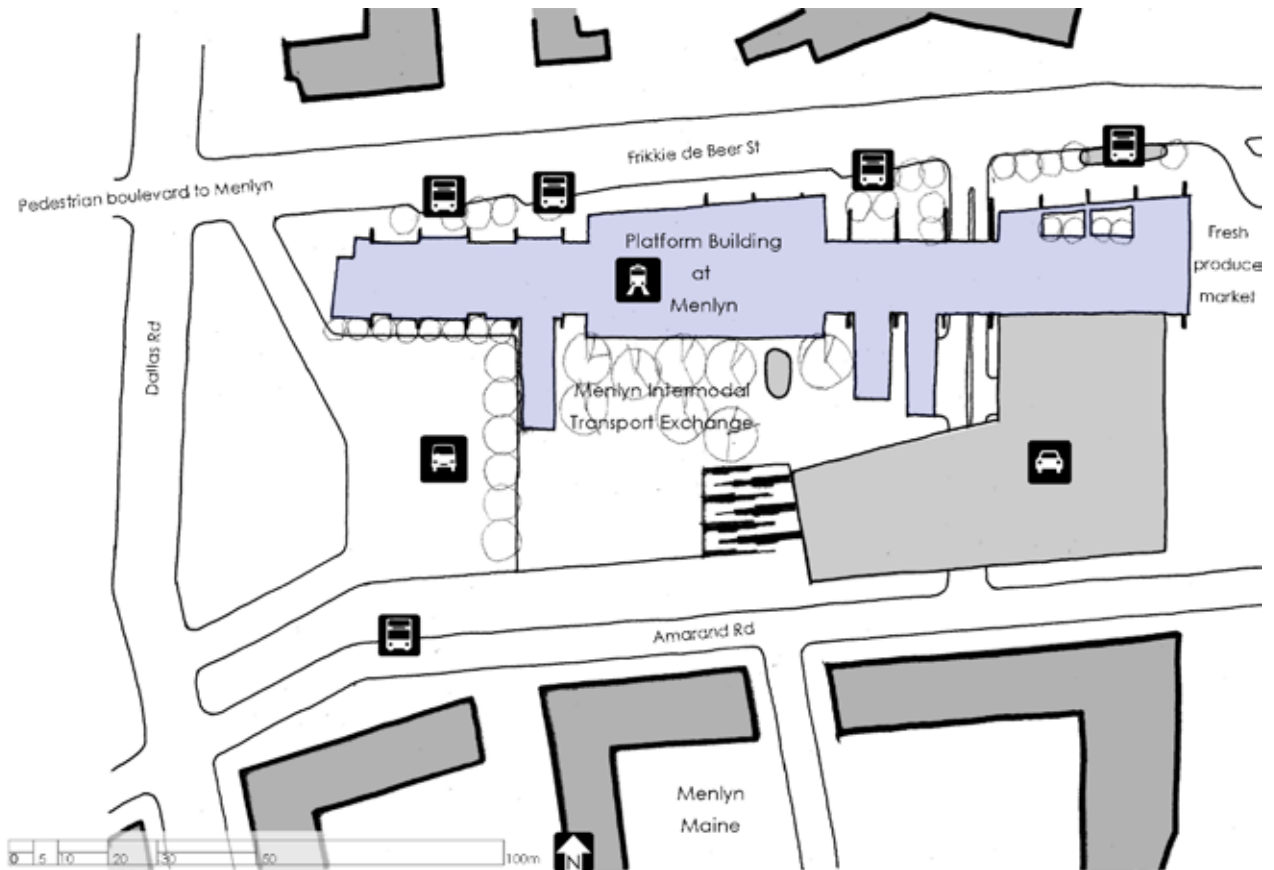

ILLUS. 7.2: Sketch of Platform Building at Menlyn from South West corner. (Above)

ILLUS. 7.3: Location of platform building on site and in relation to other transport modes. (Right)

7.1 ACCOMMODATION LIST

7.1.1 GROUND FLOOR (PUBLIC)

- Entrance/exit of underground Menlyn Gautrain station. This area forms the focus and identity of the building
- Circulation areas including the platform and three stairways to the first floor
- Gautrain facilities that include:
 - Information desk
 - Ticket kiosk
 - Automatic ticket machines
 - Office
- Services that include:
 - Freight lift
 - Refuse area
 - Store rooms
- Three public ablution facilities located near the taxi rank, Gautrain entrance/exit and BRT stop.

- BRT stop
- BRT/Bus ticket kiosk
- Luggage storage
- Book shop
- Kiosks

7.1.2 FIRST FLOOR (SEMI-PUBLIC/PRIVATE)

- 8 Boardroom/exhibition spaces that include:
 - kitchenettes
 - store rooms
- Kitchen
- Restaurant
- Public ablution
- Seating areas
- Waiting area
- Reception
- Circulation areas including 2 stairways to the second floor

Second Floor

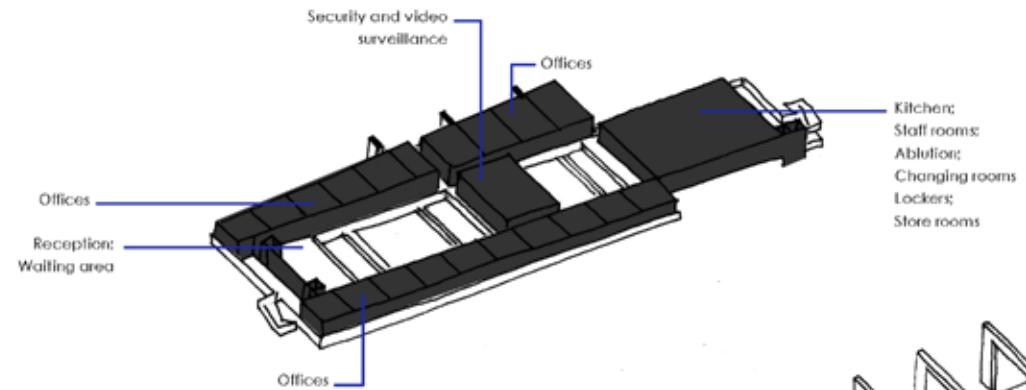

ILLUS. 7.4: Location of facilities in the Platform Building at Menlyn.

First Floor

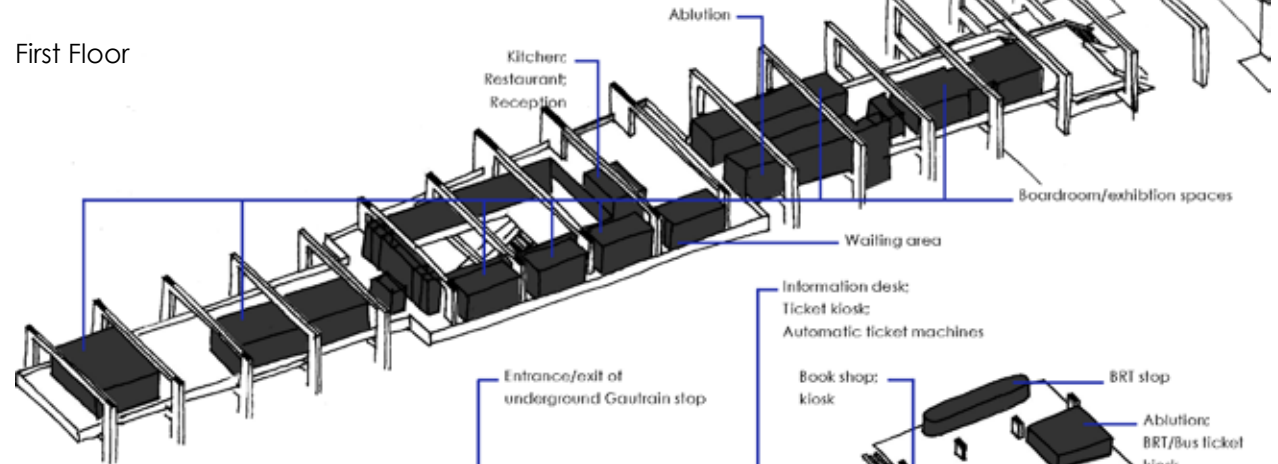

7.1.3 SECOND FLOOR (PRIVATE)

- Reception
- Waiting area
- Offices for:
 - Gautrain management
 - Taxi management
 - Bus management
 - Station manager
- Security and video surveillance office
- Kitchen
- Staff room
- Ablution
- Store room
- Facilities for the station staff that include:
 - Ablution
 - Staff room
 - Changing including showers and lockers

Ground Floor

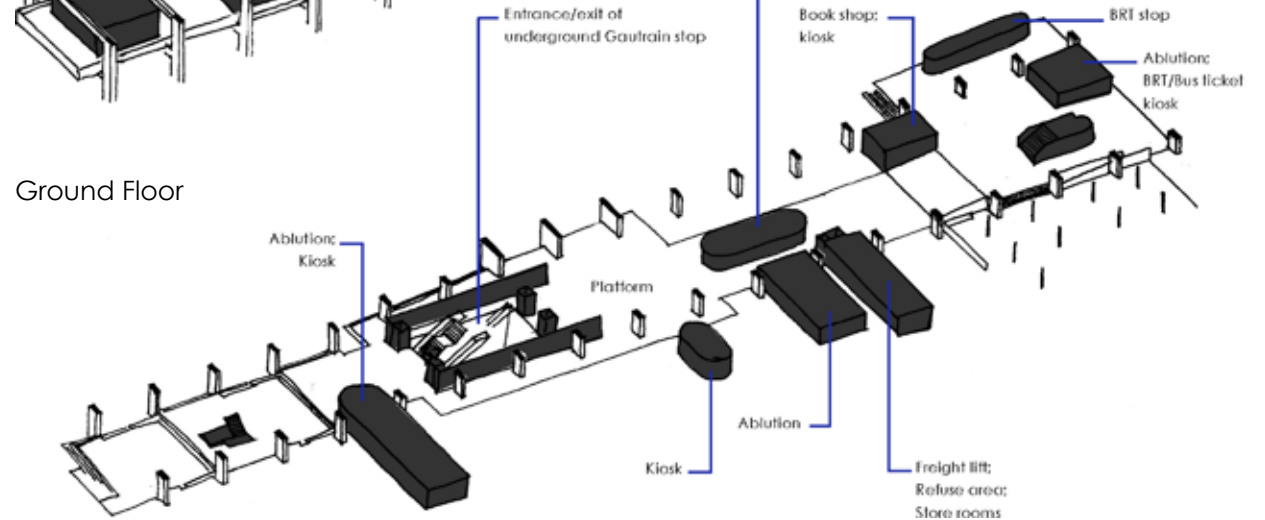

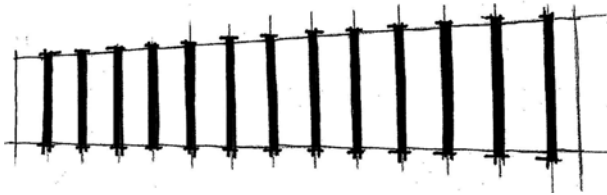

ILLUS. 7.5: Parti diagram.

7.2 FINAL DESIGN

The Gautrain Platform Building at Menlyn is designed to serve as a platform for transition and integration of the Gautrain and other public transport modes present at the Menlyn Intermodal Transport Exchange.

The parti diagram (illus. 7.5) indicates a form divided by vertical lines at regular intervals. This is translated into built form as a platform divided by prominent column-and-beam structures (illus. 7.6). These off-shutter concrete structures form different spaces and give the users a sense of scale as they move through the building. The structure influences and informs the rest of the building in planning and finishes.

The building is divided into three levels that progress from public to private (illus 7.1). The

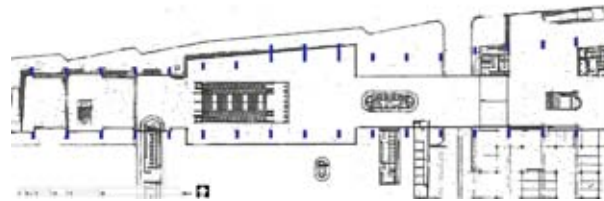

ILLUS. 7.6: Platform and column-and-beam structure.

facilities, echo the users of the building, and are placed like objects on the platform. The placement of these 'objects' becomes more deliberate and increases as the building progresses from public to private (illus. 7.7). The glazed, tectonic 'objects' stand in contrast with the stereotomic nature of the building structure (illus. 7.9). This contrast emphasises the seemingly haphazard placement of the 'objects' on the platform.

The location of the entrance/exit to the underground Gautrain station is a crucial identifying aspect of the Gautrain Building at Menlyn. This importance is indicated by a metal fabric box-like structure that surrounds this entrance/exit and extends up to the roof level of the building (illus. 7.10). This GKD metal fabric structure will be visible from afar and

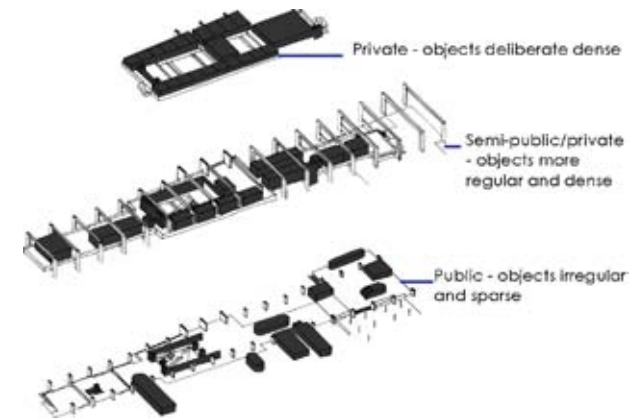

ILLUS. 7.7: Objects on platform.

gives the impression of being a solid mass. When viewed from near, the mesh structure will become lightweight and transparent. The same GKD metal fabric used for the structure is used in the rest of the building as screens on the western façade and at service ducts.

The metal fabric of the structure is divided into different panels by means of a grid pattern (illus 7.11). This grid becomes smaller as the building moves from public to private and is projected into other areas of the building. The grid serves to contribute to and communicate the human scale of the building.

ILLUS. 7.8: Perspective of Platform Building at Menlyn form South East corner. (Opposite)

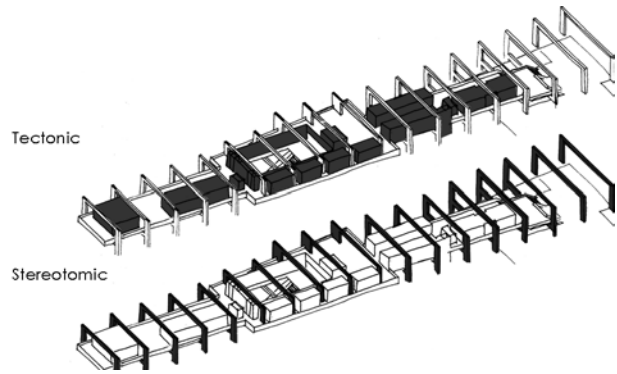

ILLUS. 7.9: Example of stereotomic vs. tectonic on second floor.

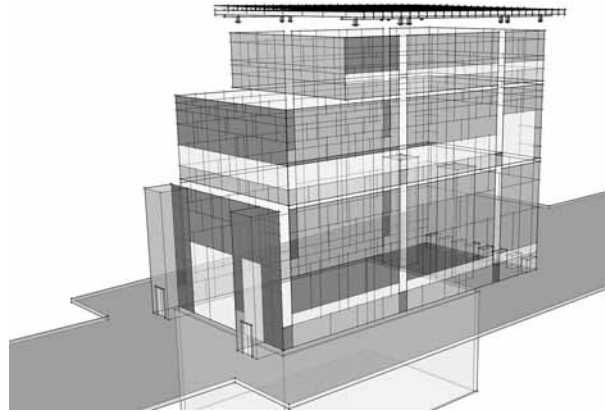

ILLUS. 7.10: GKD metal fabric structure.

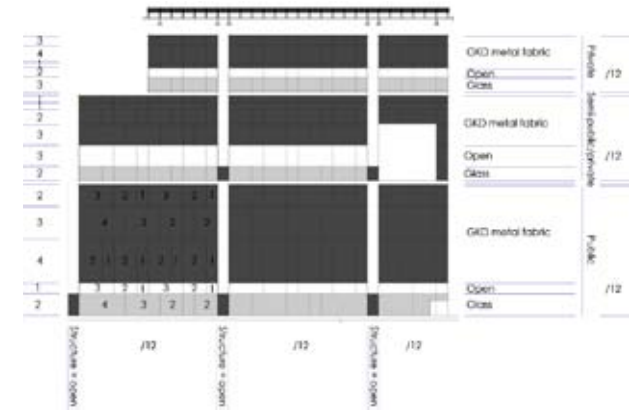

ILLUS. 7.11: Example of grid pattern.

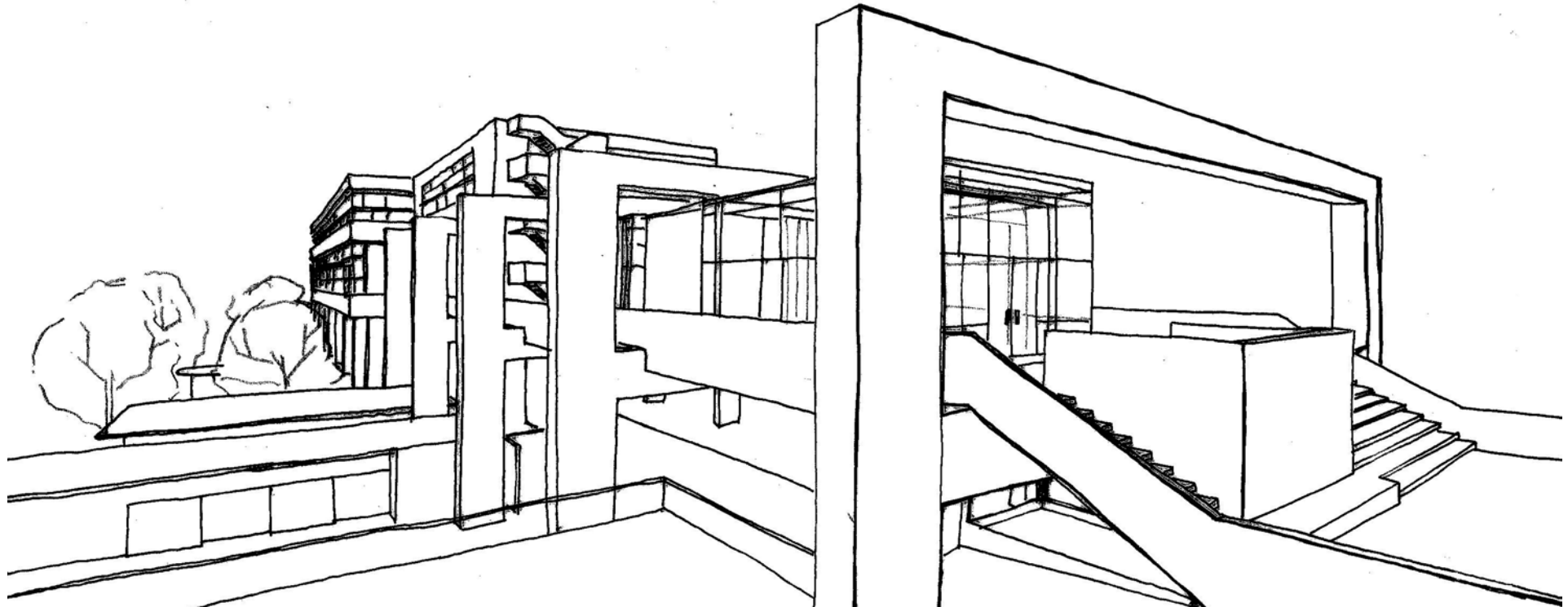

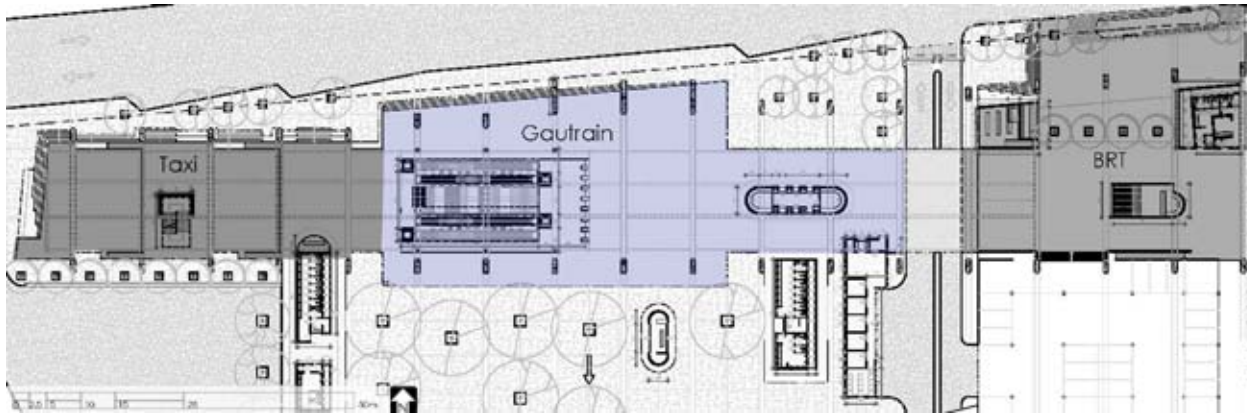

ILLUS. 7.12: Ground floor plan indicating different functional areas.

The ground floor plan is divided into three main platform areas (illus. 7.12). The first platform area is located alongside the proposed taxi rank. This platform area is void of anything besides stairs leading to the first floor and signage. The platform will be used by pedestrians transitioning in an East-West direction and it is envisioned that the platform will be appropriated by the taxi rank users.

The second platform area, and focus of the project is the Gautrain platform. The building entrance, entrance/exit to the underground Gautrain station, Gautrain facilities and main circulation routes are located on this platform.

The third platform area is the BRT platform. This platform is the location of the BRT stop, BRT and bus ticket kiosk, book shop and entrance to the

parking garage. All three platforms have public ablution facilities and circulation routes to the first floor.

The conference/exhibition spaces as well as the restaurant are located on the first floor. The conference/exhibition spaces, placed like objects on the platform can be rented and used privately, or the entire floor can function as a conference/exhibition space.

The management offices of the different transport facilities, security and staff facilities are located on the second floor. This floor reads as a glass box hovering above the platform underneath, providing further differentiation between public and private space (illus. 7.13).

The vision of the building is to be understated subtle; a backdrop to the vibrancy of its user, but elegant in its own right.



ILLUS. 7.13: South elevation of Platform Building at Menlyn.



ILLUS. 7.14: Perspective of Platform Building at Menlyn from North West corner.

CHAPTER 8

TECHNICAL RESOLUTION

This chapter will focus on the following aspects:

- Materials
- Structure
- Services
- Floor plans
- Sections
- Technical details

8.1 MATERIALS

The main materials used in the Platform Building at Menlyn will now be discussed.

8.1.1 CONCRETE

“Concrete is extremely durable, easy to work with, easy to connect and, in conjunction with steel, has a high loadbearing capacity” (Hertzog et al., 2004: 101). The predecessor of concrete, lime mortar, was used as a building material in buildings as early as 12 000 B.C.,

but the invention of Portland cement in 1824 introduced concrete to modern architectural form (Hertzog et al., 2004: 101).

The mouldability of concrete and its various constituents enable the material to be used in many different forms and finishes.

The structure of the Platform Building at Menlyn will be cast-in-situ concrete with an off-shutter finish. This makes the construction of the big column-and-beam structures possible and enables the use of the grid (used throughout the building) to be implemented in the concrete finish.

The *Artevia* concrete range by Lafarge will be used as illustrated in illus. 8.1. These different finishes will aid in distinguishing various spaces

in the building as well as mirror and accentuate the rhythm created by the column-and-beam structures.

ILLUS. 8.1: Illustration of use of concrete in design.



Off-shutter finish according to grid with exposed tie



Joints refer to column-and-beam structure

Artevia Polish (matt finish on stairs)

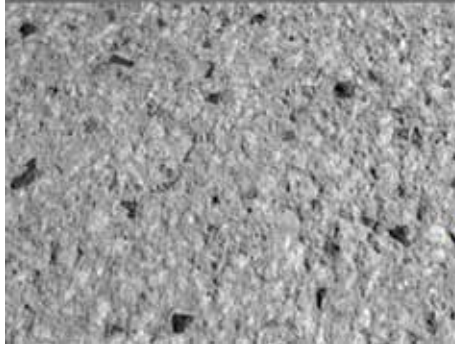

Artevia Exposed

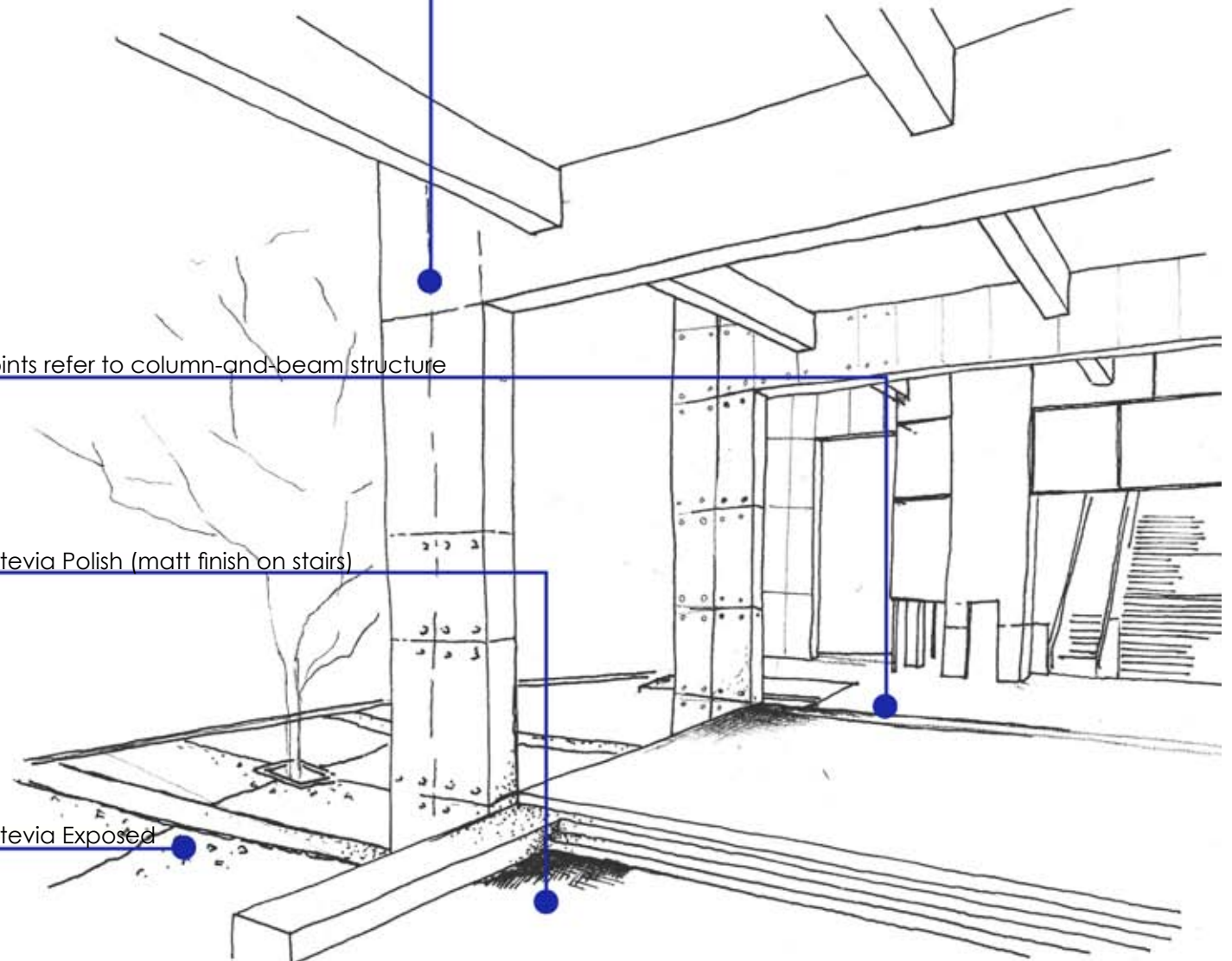



ILLUS. 8.2

8.1.2 SEMI-TRANSPARENT PHOTOVOLTAIC GLASS

The glass roof structure is placed above the Gautrain entrance/exit in the Platform Building will make use of semi-transparent glazing panels. These panels make use of photovoltaic silicone cells sandwiched between glass to generate electricity. The glazing panels allow diffused light to pass through.

The semi-transparent photovoltaic glazing panel consists of three layers, a tempered glass sheet, an amorphous high grade silicone cell film and a glass sheet or high grade polymer. The thin film is 0.3 microns thick and cells are connected in a series circuit. The cells are chemically treated to have a positive and negative side. When the sun's rays come in contact with the cells, the electrons enter an excited state and flow

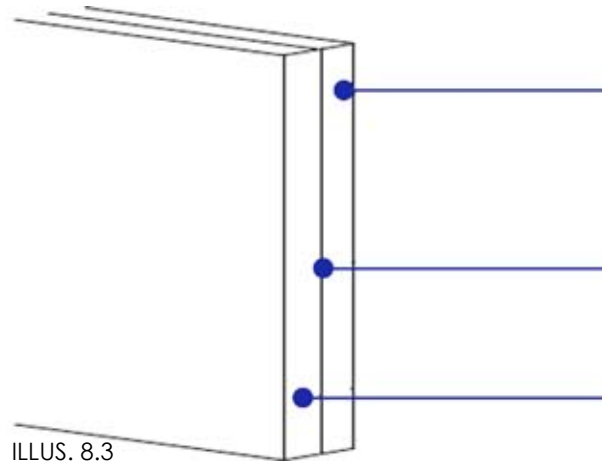

ILLUS. 8.3

Light grey glass sheet or high grade polymer

Semi-transparent amorphous silicone cell layer

Tinted tempered glass

out of the cell thereby creating electrical flow. Plug-and-play DC cables are installed on the silicone layer and edge-mounted. The glazing panel is framed, hiding the edge-mounted electrical connection system and all wiring. The DC cables are connected to an inverter which changes the energy from DC to AC. When the energy is successfully converted, it is fed into the electrical grid and used.

The amount of energy generated is sufficient to power the escalators of the Platform Building as shown in the calculations on the right.

PRODUCT: 8mm 50% clear PA1 Panel
Powerglaze by PV Glaze

FINISH:

Exterior - Tinted; Interior - Light Grey

VISIBLE LIGHT: 50% clear

HEAT CUT: 30%

POSSIBLE ENERGY GENERATED/DAY:

= roof area x 40W

= 336 x 40

= 13 440W

= 560kWh

AVERAGE ENERGY USAGE OF 1 PAIR
OF ESCALATORS/DAY: = 103kWh
(Rastogi, 2010)

ENOUGH ENERGY GENERATED PER
DAY TO SUPPLY ELECTRICITY TO 5
PAIRS OF ESCALATORS

ILLUS. 8.2: Interior view of installed semi-transparent photovoltaic glazing, location unknown. (Opposite)

ILLUS. 8.3: Construction of semi-transparent photovoltaic glazing. (Opposite)

ILLUS. 8.4: Omega 1520 GKD metal fabric.

ILLUS. 8.5: Union theological seminary, Richmond, Virginia.

ILLUS. 8.6: Doral Park, Doral, Florida.

ILLUS. 8.7: Woven-in bar with spring GKD metal fabric attachment method.

ILLUS 8.4

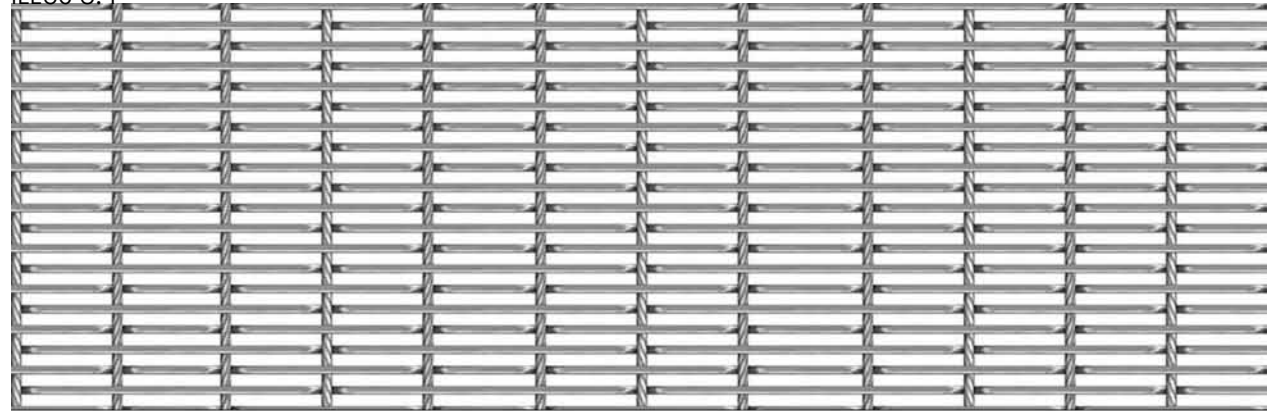

8.1.3 METAL FABRIC

Metal fabrics were originally invented for industrial applications such as filters (Hertzog et al. 2004: 166). Metal fabrics enable the design of permeable building facades. Different effects are created depending on the position of the viewer, the reflective properties of the material, the aperture of the mesh, the thickness and texture of the material (Hertzog et al., 2004: 166).

In addition to visual effects, metal fabrics are applied in the Platform Building at Menlyn to:

- shade certain areas from the sun
- redirect light
- separate and indicate different spaces
- cover service shafts
- allow for natural ventilation

ILLUS 8.5



ILLUS 8.6



ILLUS 8.7

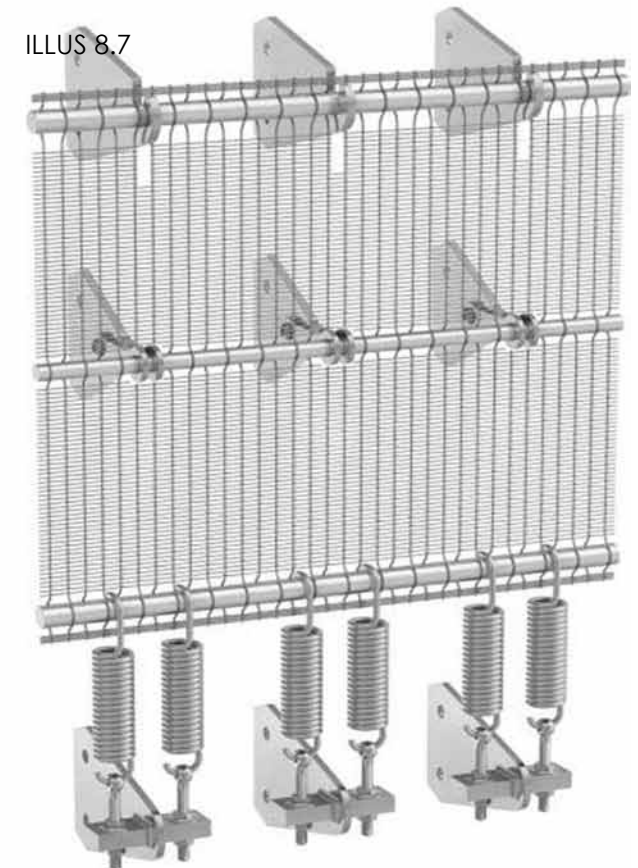

8.2 STRUCTURAL SYSTEM

Primary column-and-beam structure

Secondary concrete beams

Concrete slabs

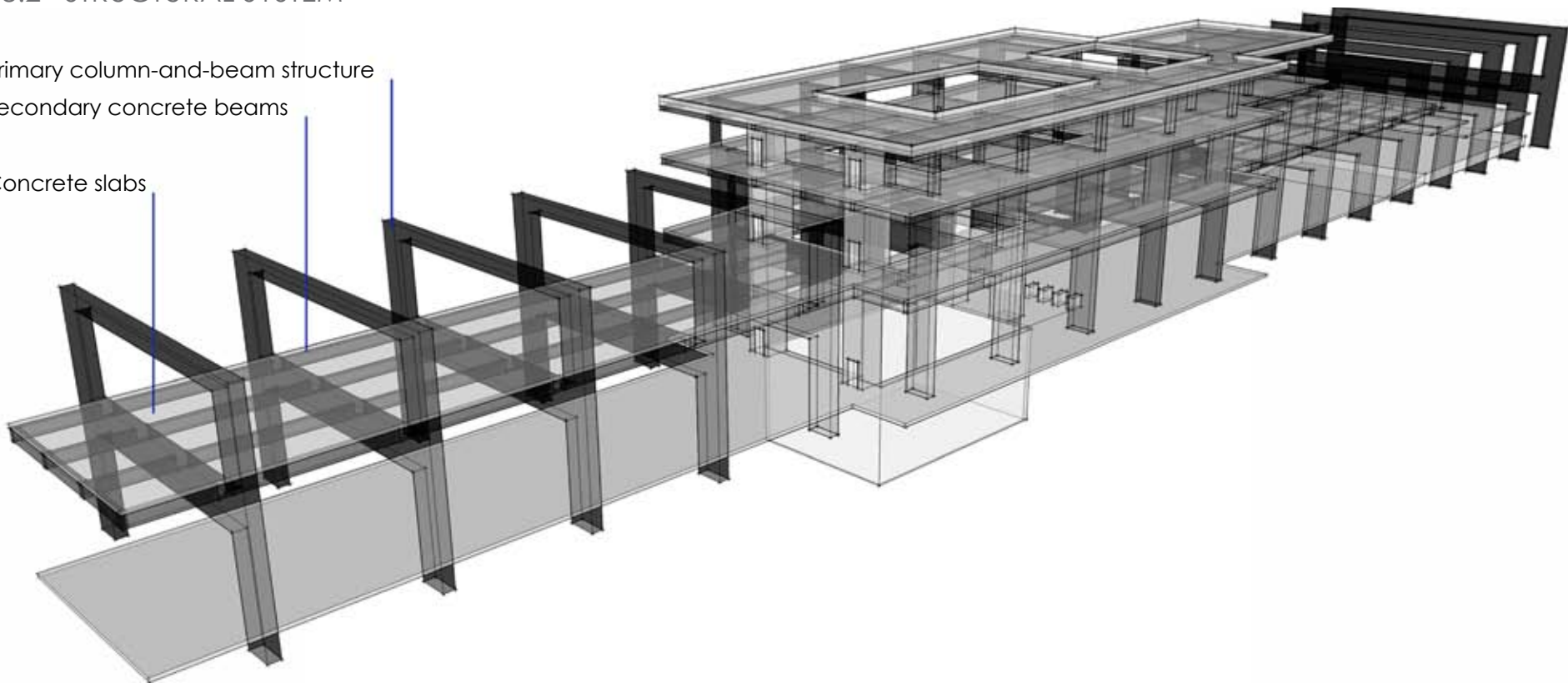

ILLUS. 8.8: Perspective of the structural system of the Platform Building at Menlyn. (Below)

ILLUS. 8.9: Exploded axonometric of the structural system of the Platform Building at Menlyn. (Opposite)

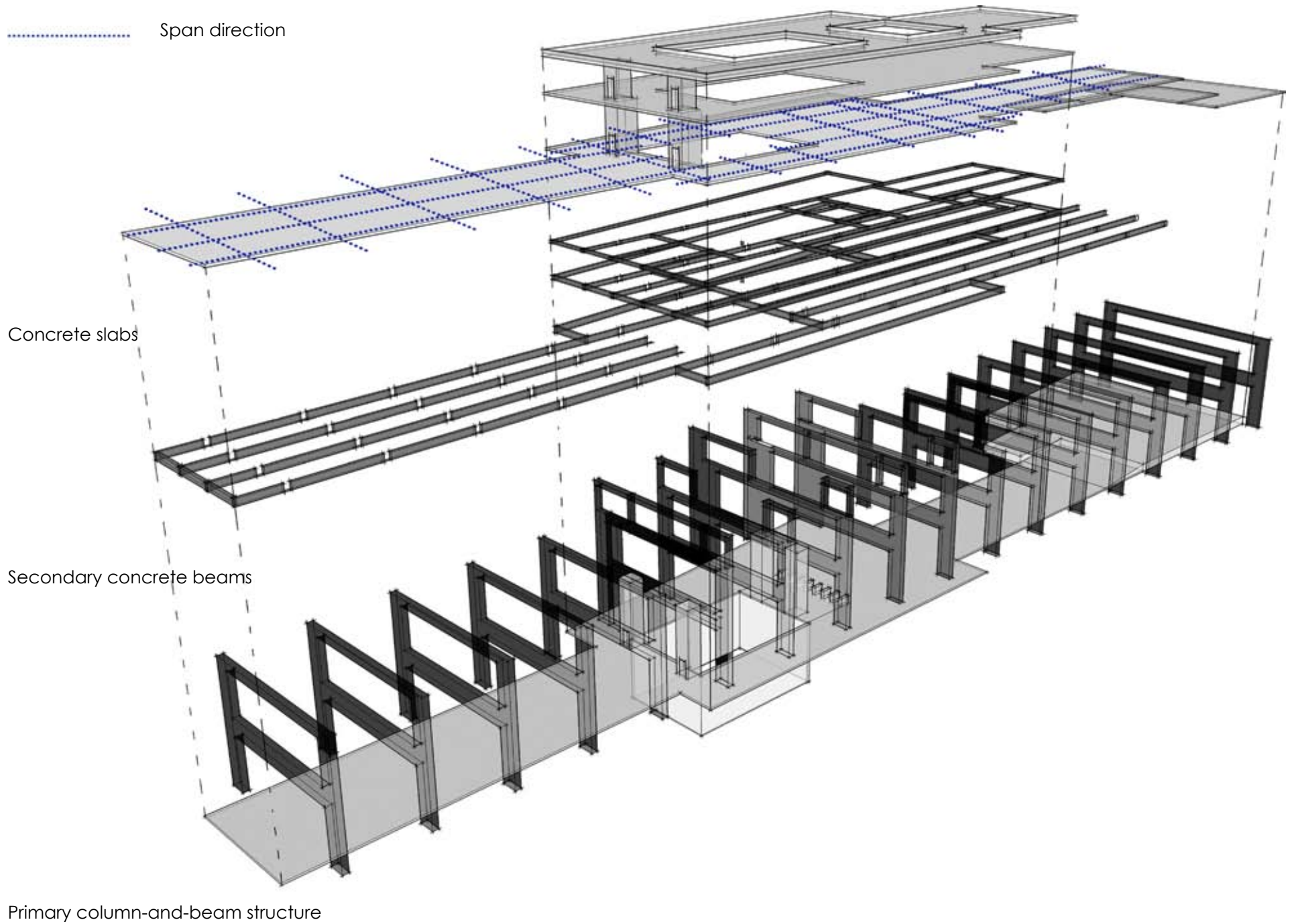

8.3 METAL FABRIC BOX-LIKE STRUCTURE

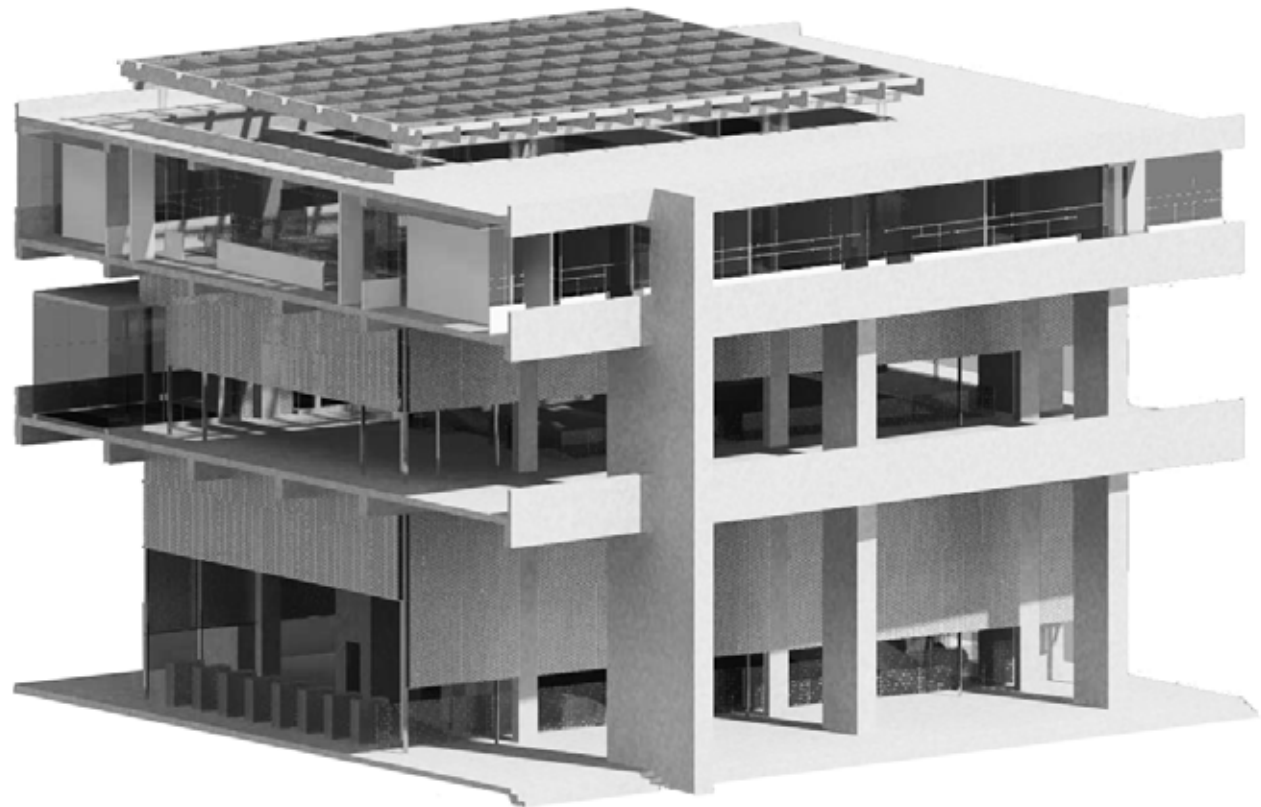

ILLUS. 8.10: Perspective of the metal fabric box-like structure of the Platform Building at Menlyn. (Below)

ILLUS. 8.11: Graphic portrayal of the grid used for the metal fabric box-like structure. (Opposite)

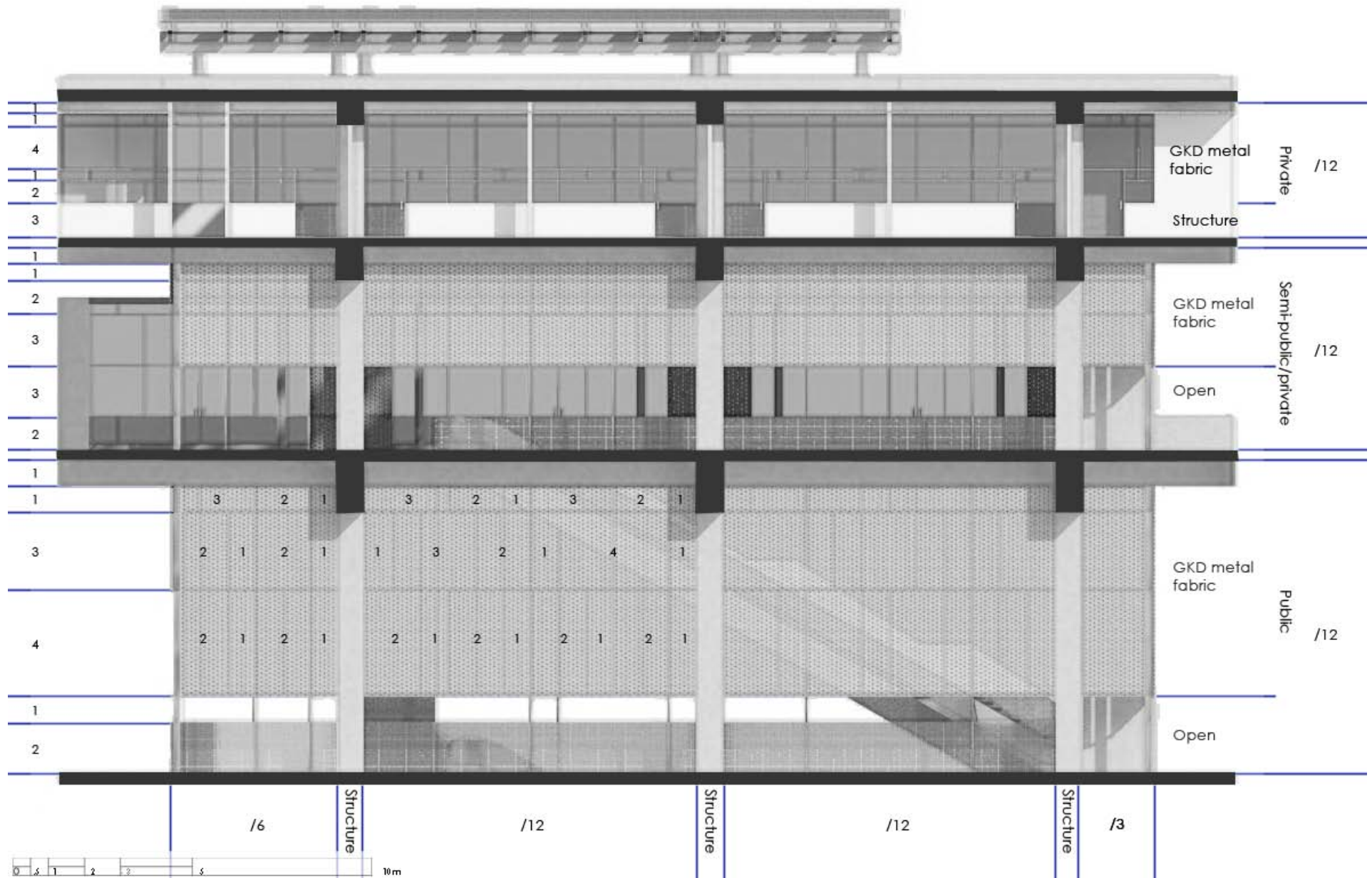

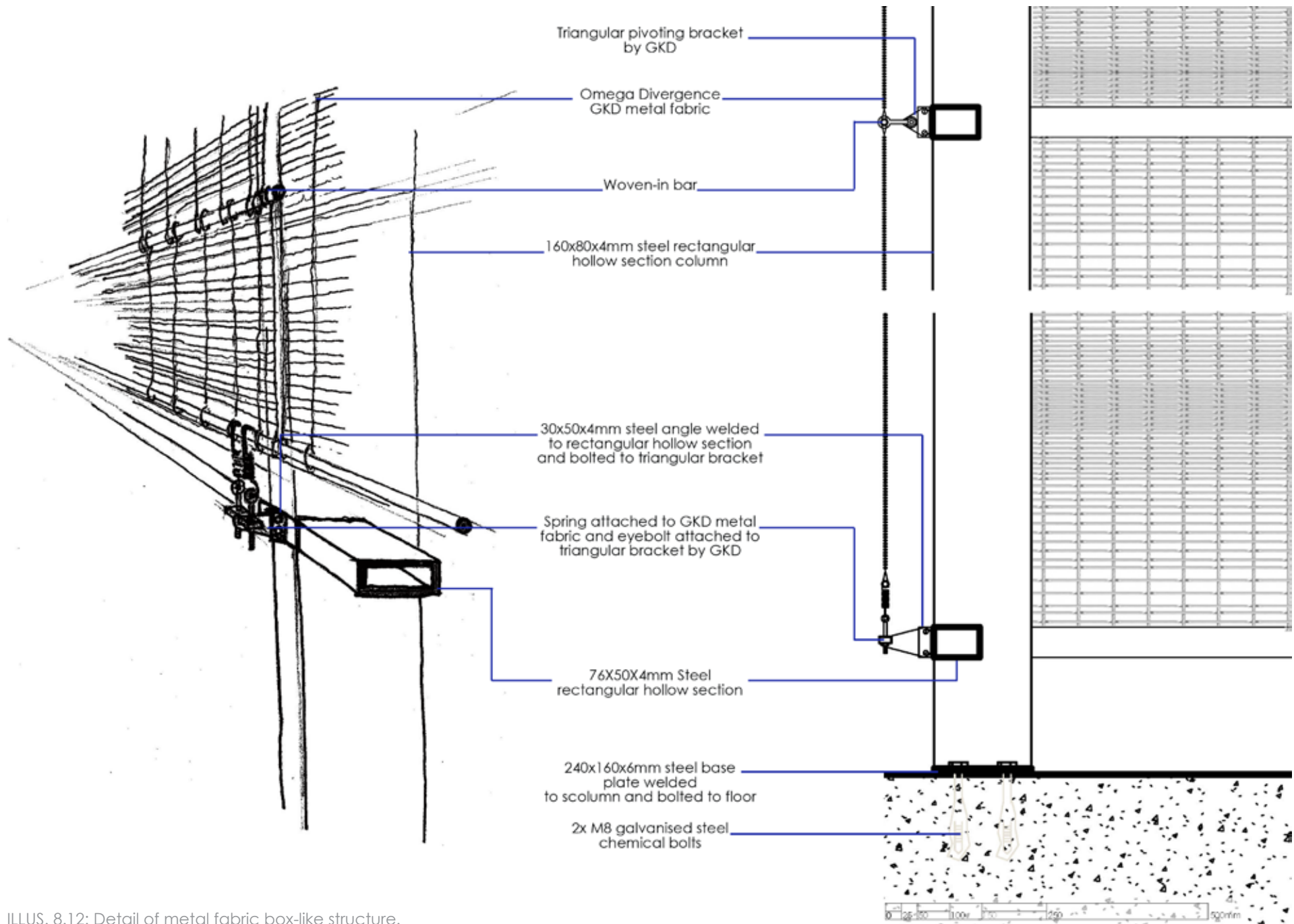

ILLUS. 8.12: Detail of metal fabric box-like structure.

8.4 CIRCULATION

KEY

- Elevator
- Stairs
- Ablution
- Offices
- Ticket kiosk
- Conference/exhibition space
- Rest/restaurant seating area
- Restaurant
- Kiosk
- Gautrain
- BRT stop
- Parking Garage
- Taxi rank

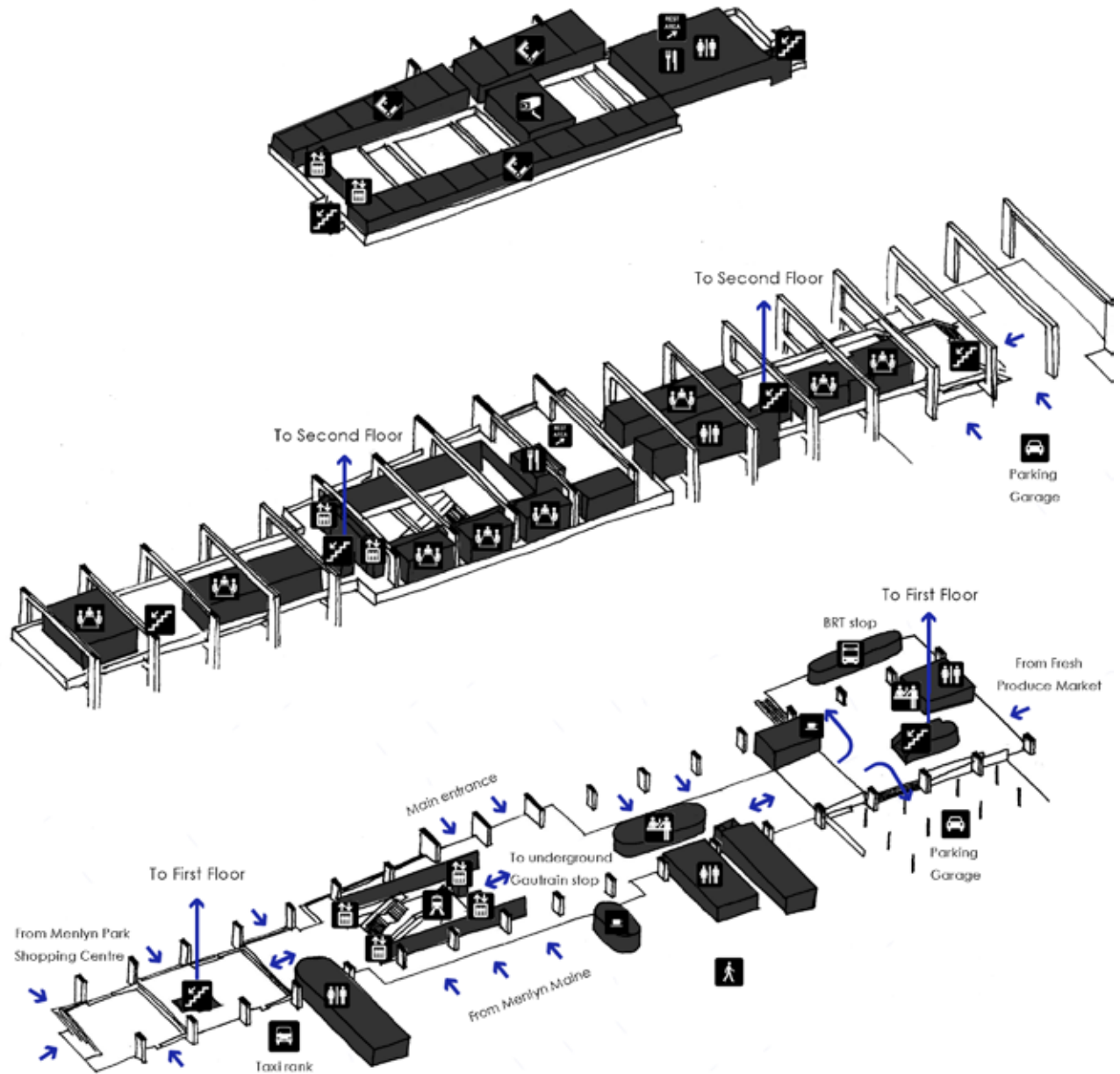

ILLUS. 8.13: Circulation routes.

8.5 VENTILATION

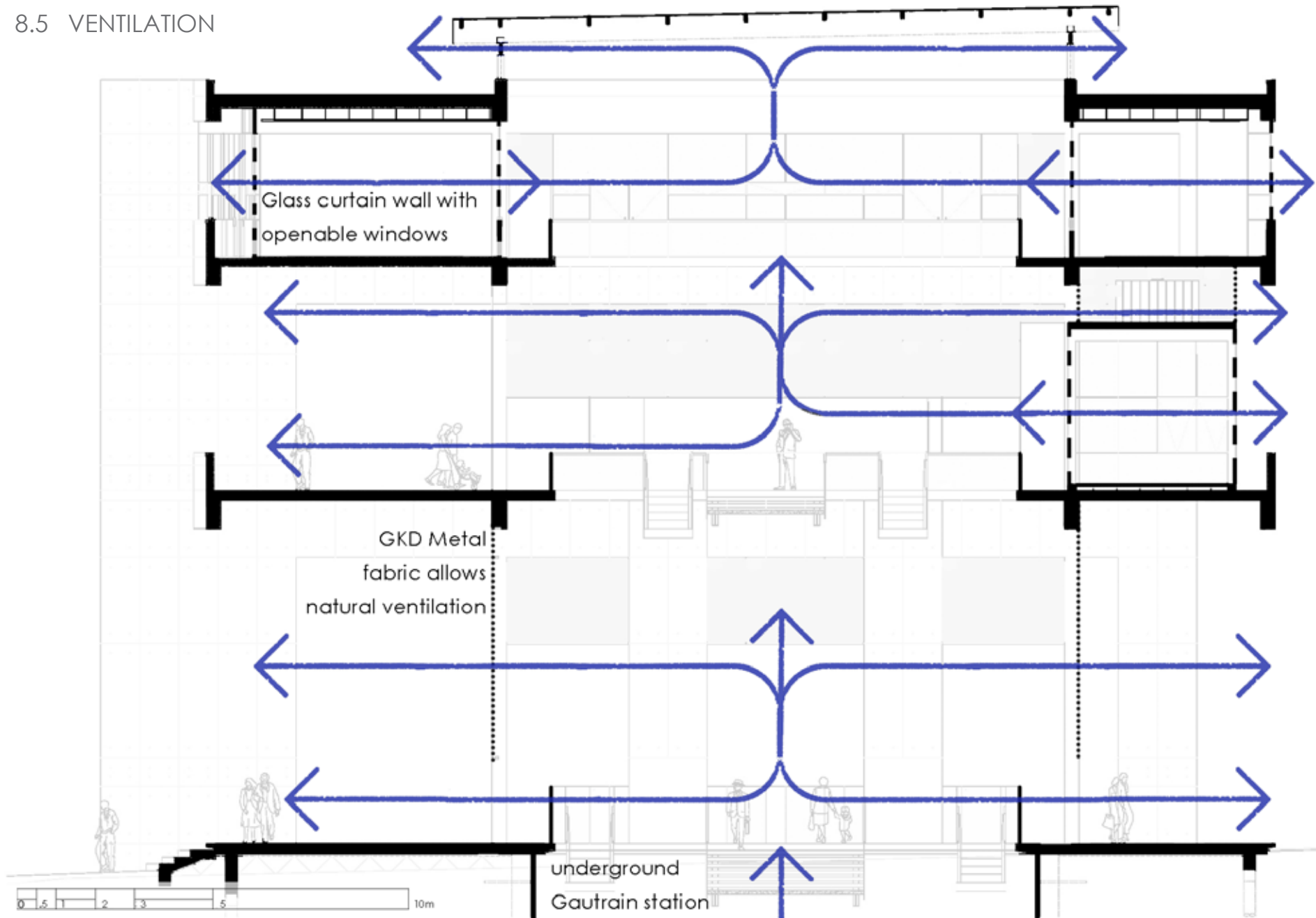

ILLUS. 8.14: Natural ventilation system.

8.6 DRAINAGE & SOLAR ENERGY

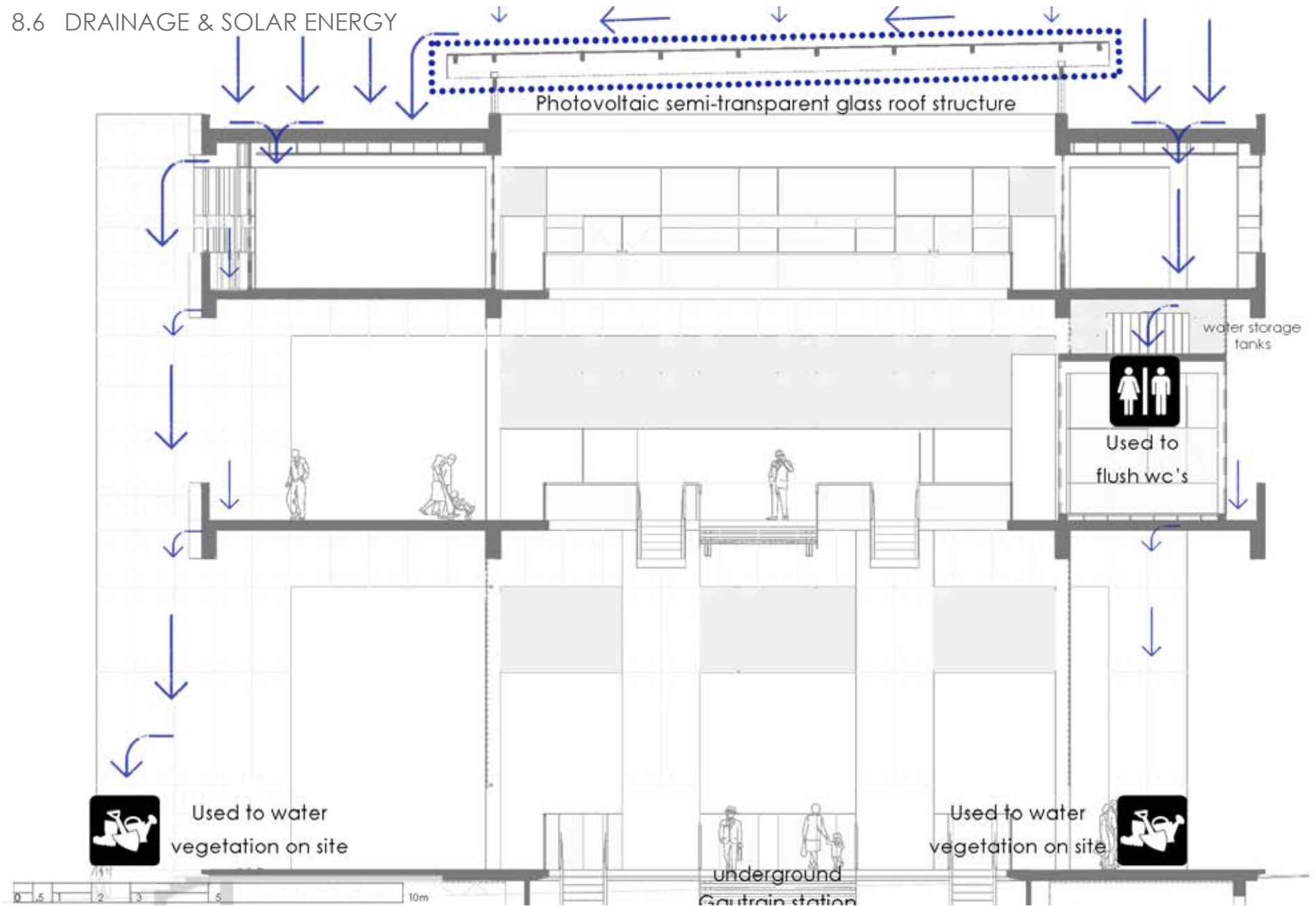

ILLUS. 8.15: Rainwater collection and solar energy systems.

8.7 ELEVATIONS



ILLUS. 8.16: North elevation.



ILLUS. 8.17: South elevation.

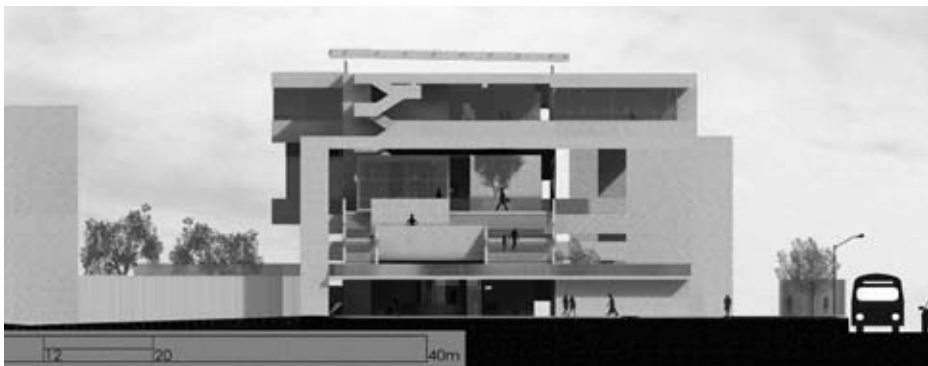

ILLUS. 8.18: East elevation.



ILLUS. 8.19: West elevation.

8.8 SITE PLAN

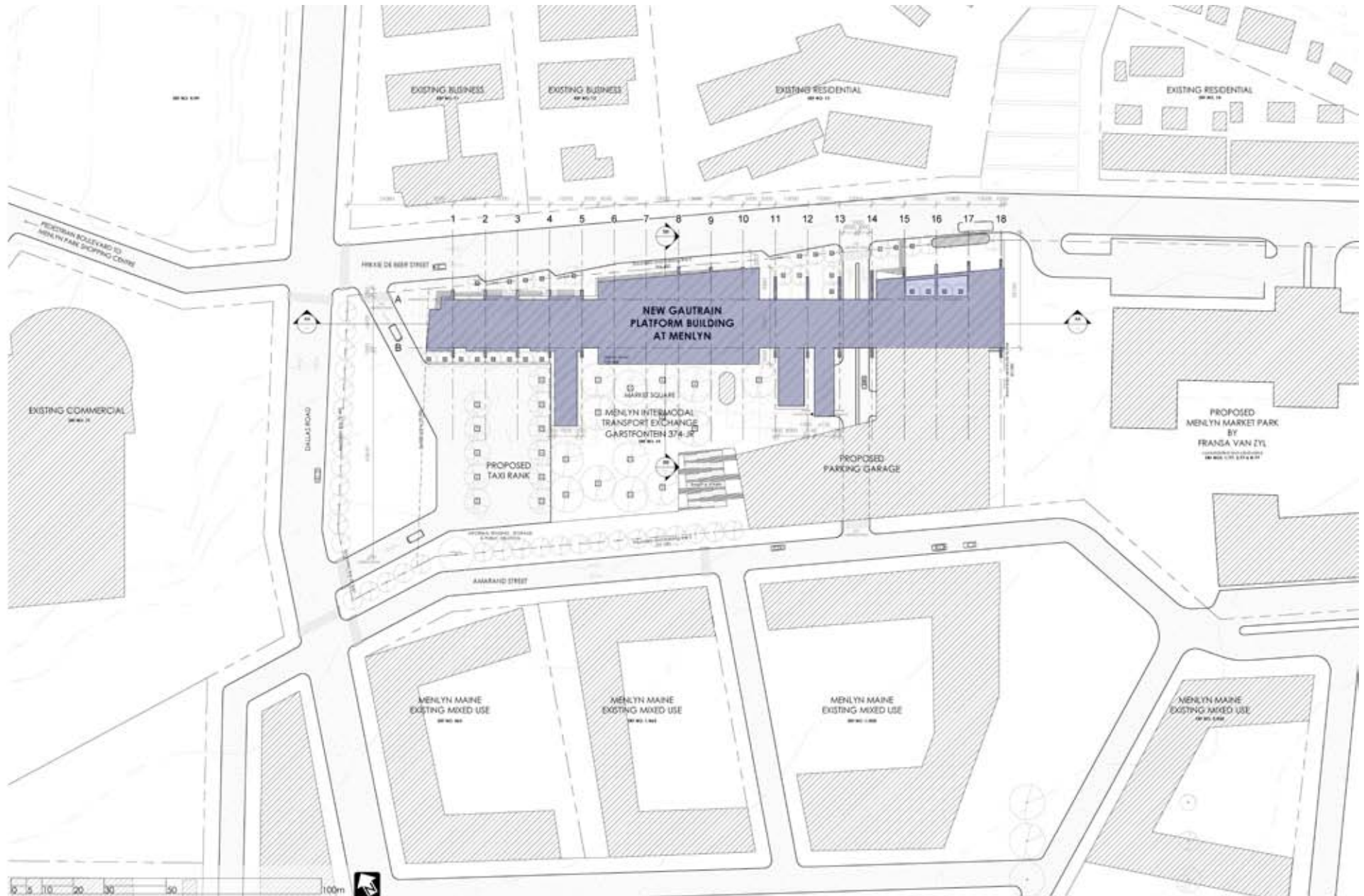

ILLUS. 8.20: Site plan.

8.9 GROUND FLOOR PLAN

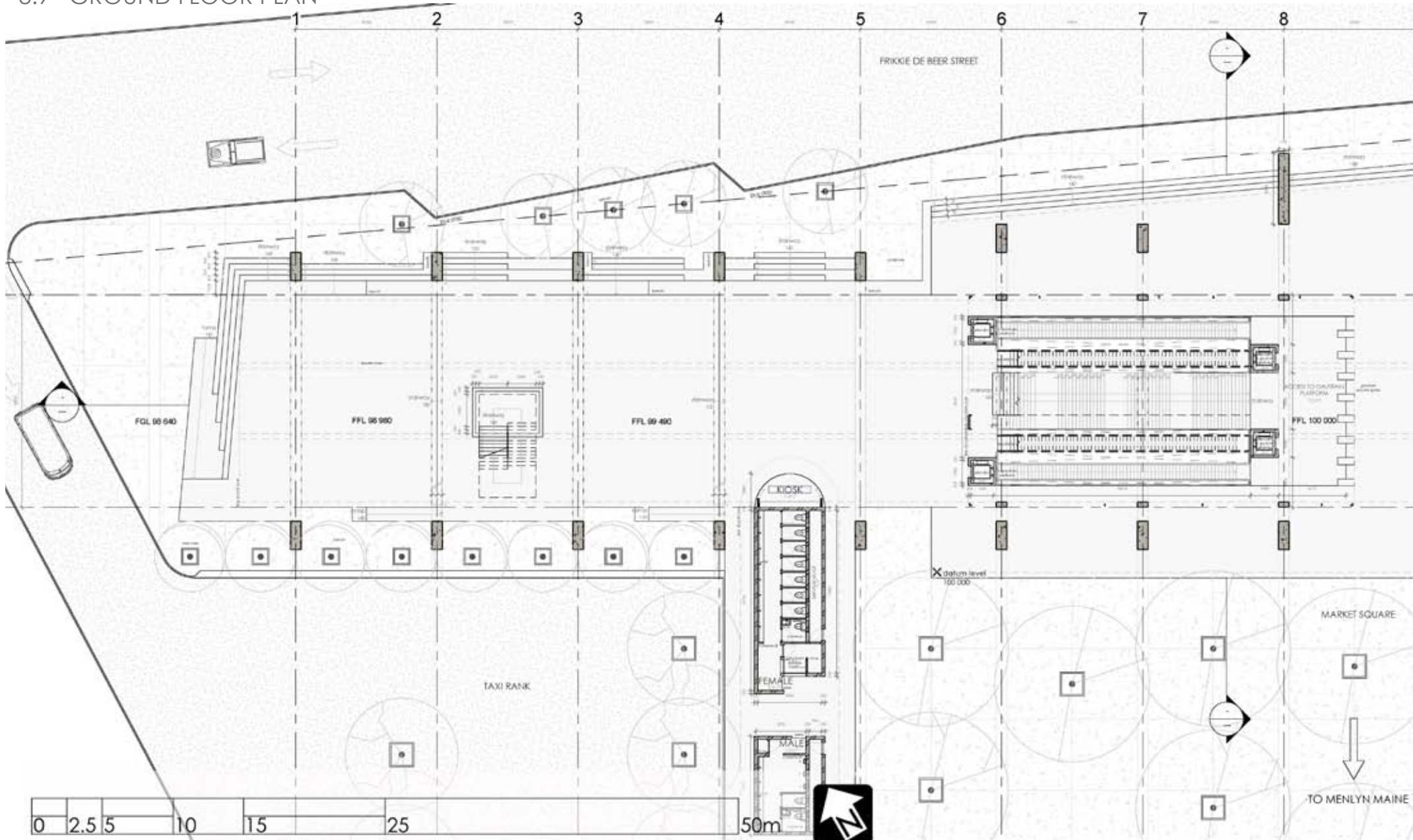

ILLUS. 8.21: Ground floor plan.

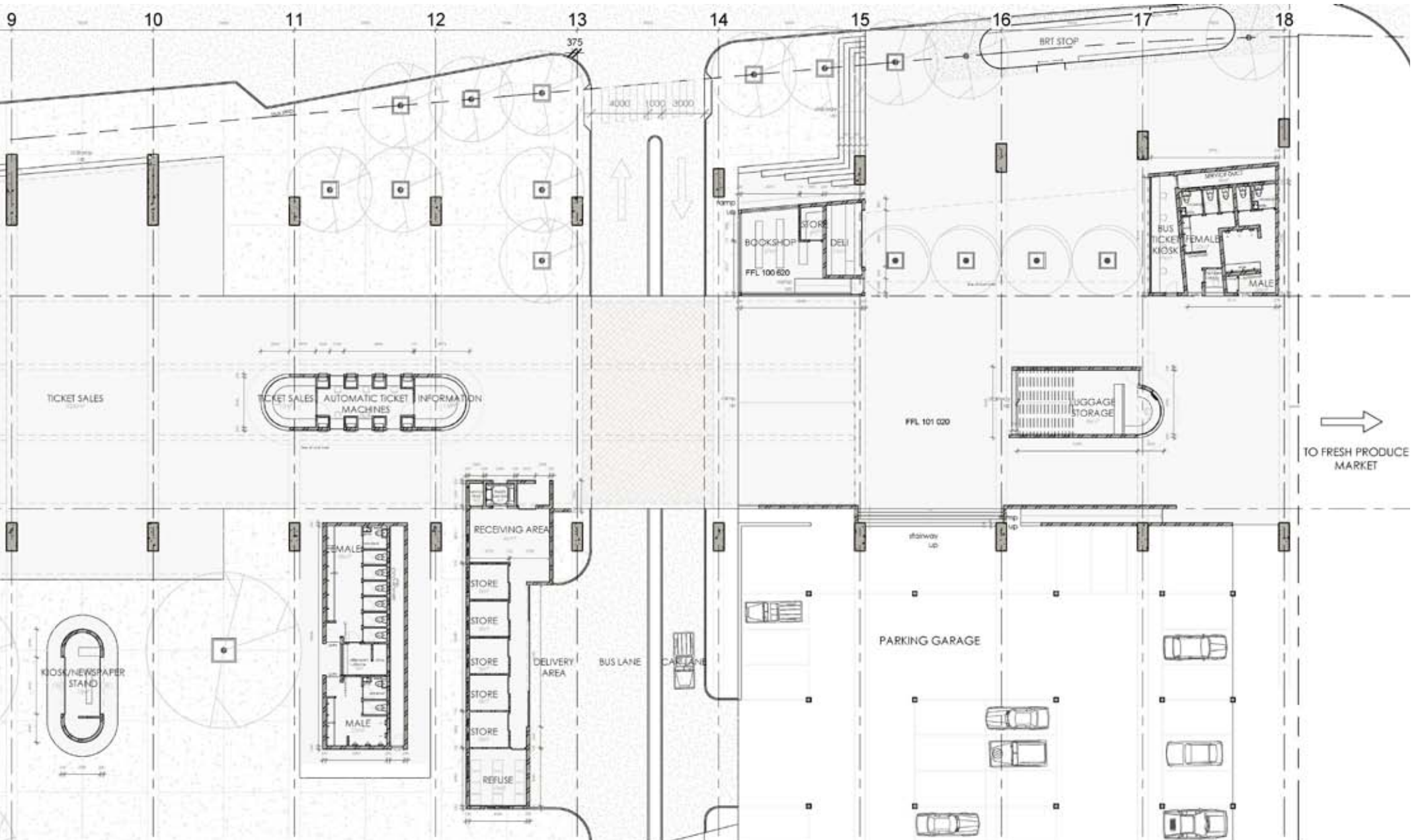

8.10 FIRST FLOOR PLAN

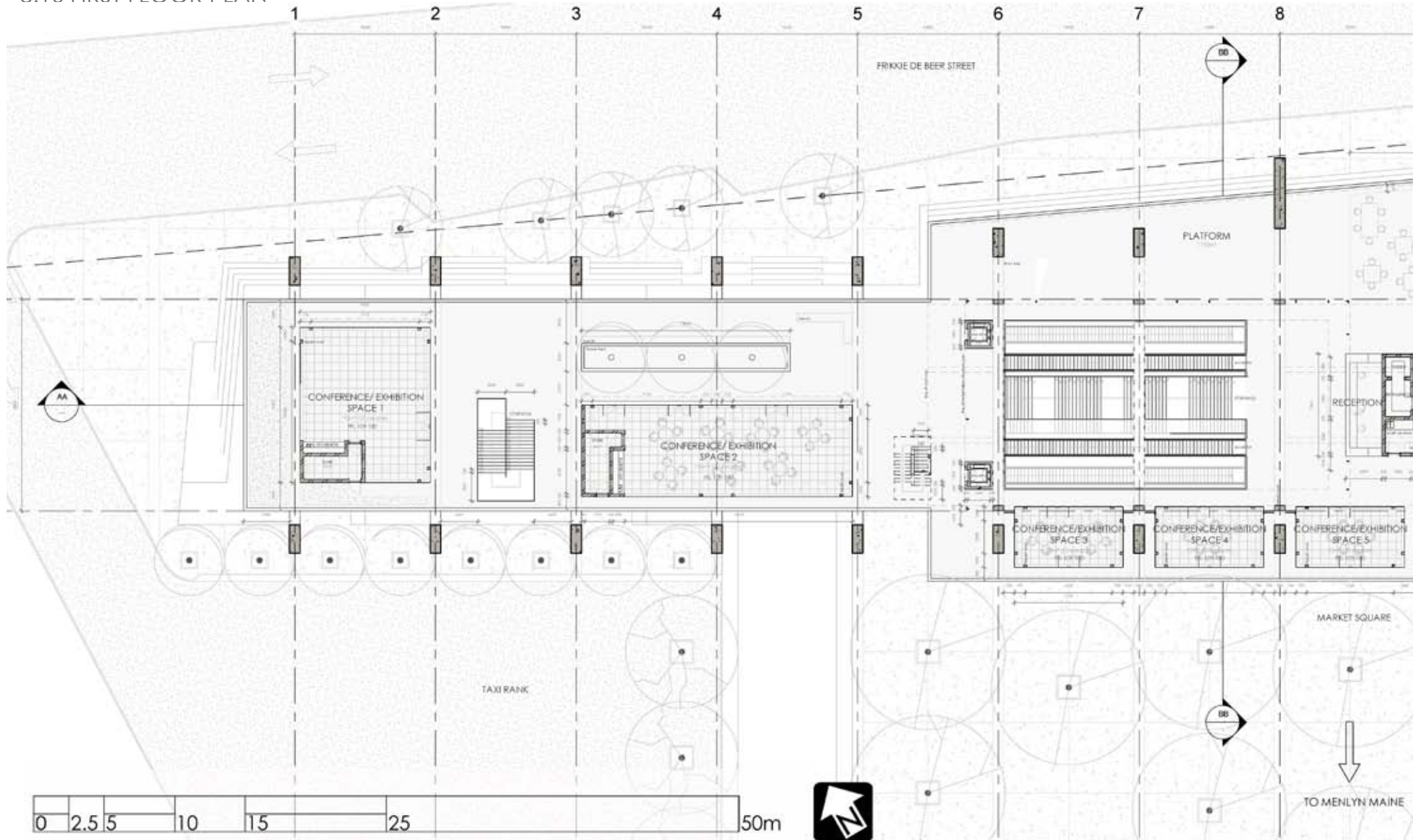

ILLUS. 8.22: First floor plan.

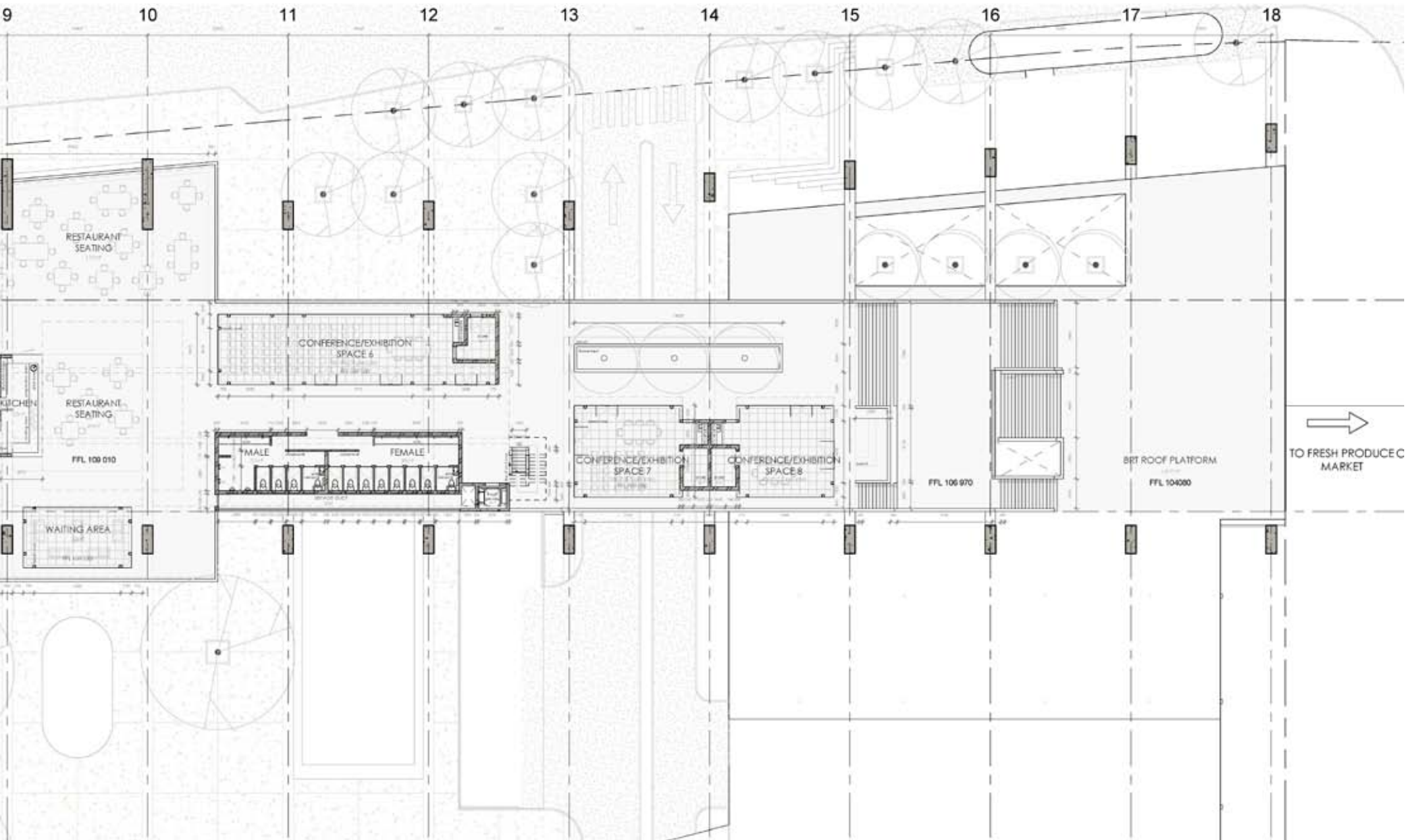

8.11 SECOND FLOOR PLAN

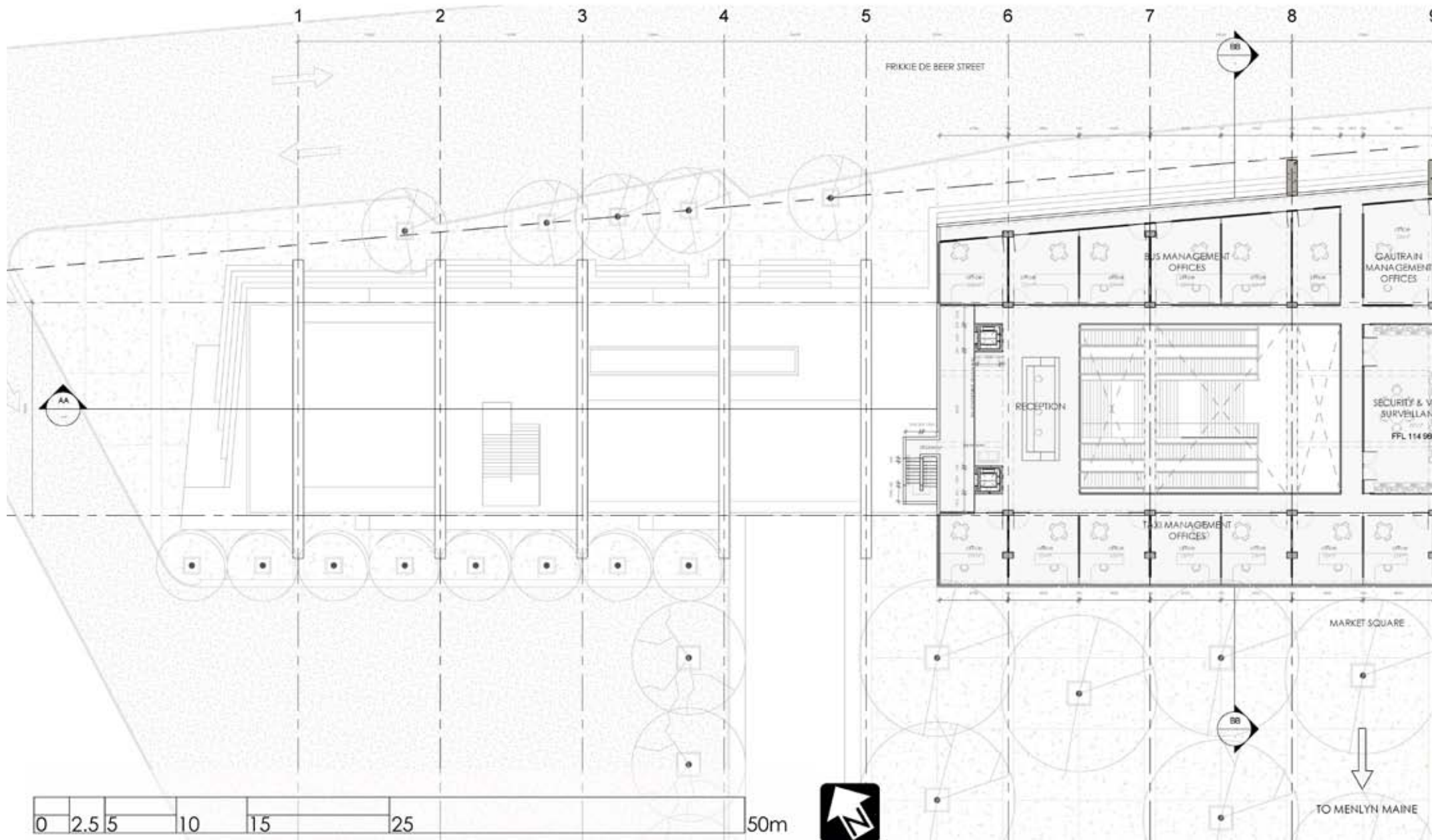

ILLUS. 8.23: Second floor plan.

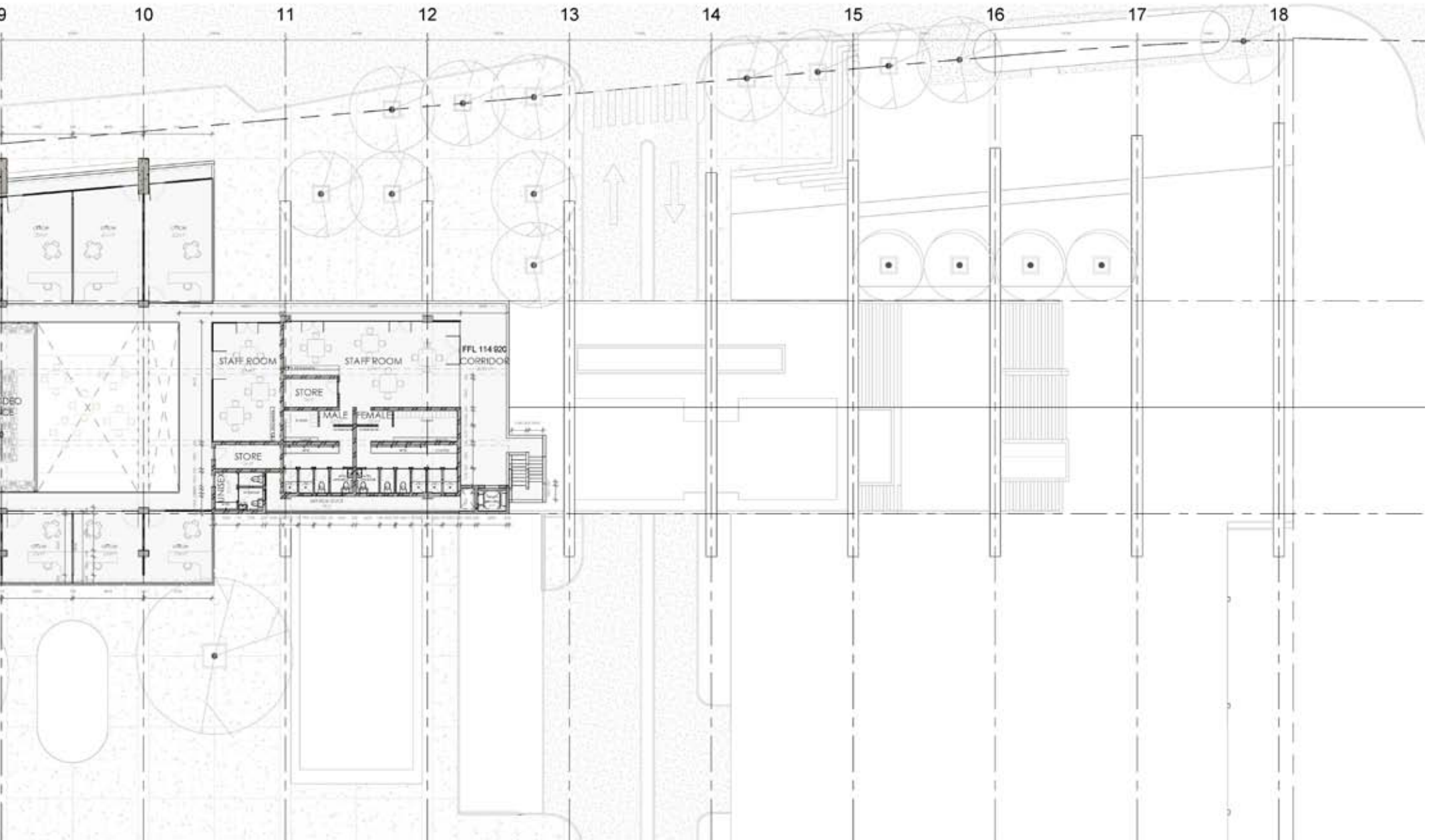

8.12 ROOF PLAN & DETAIL

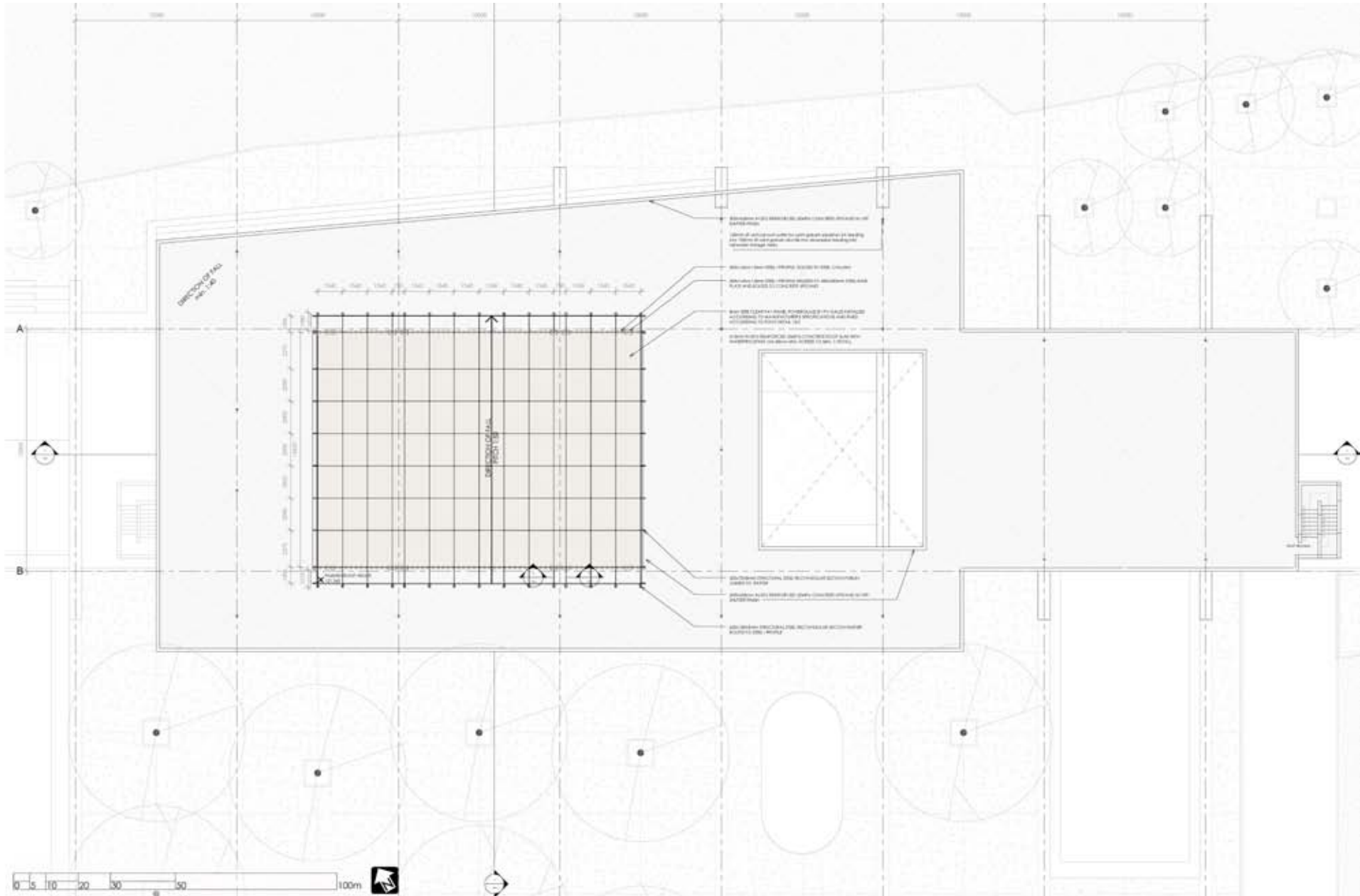

ILLUS. 8.24: Roof plan.



ILLUS. 8.25: Glass canopy at California Academy of Sciences (2008) by Renzo Piano.

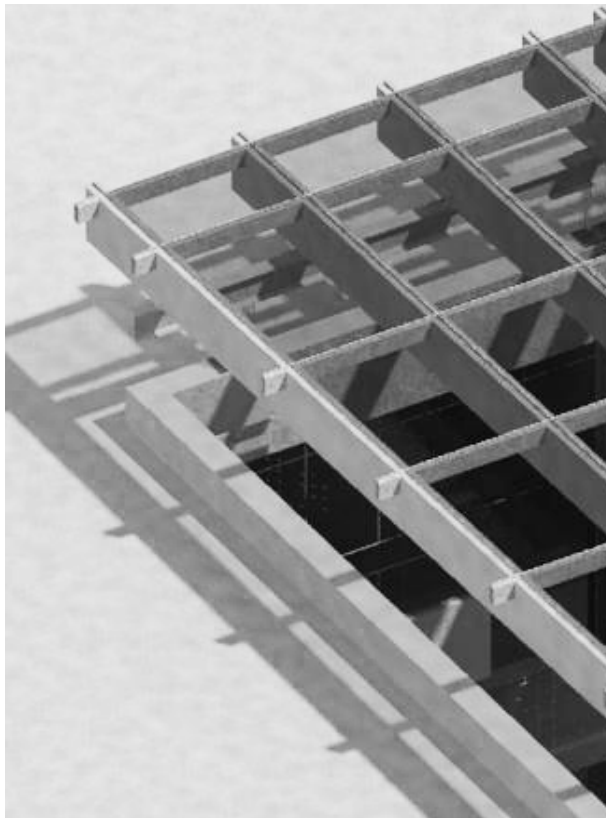

ILLUS. 8.26: Glass roof structure perspective.

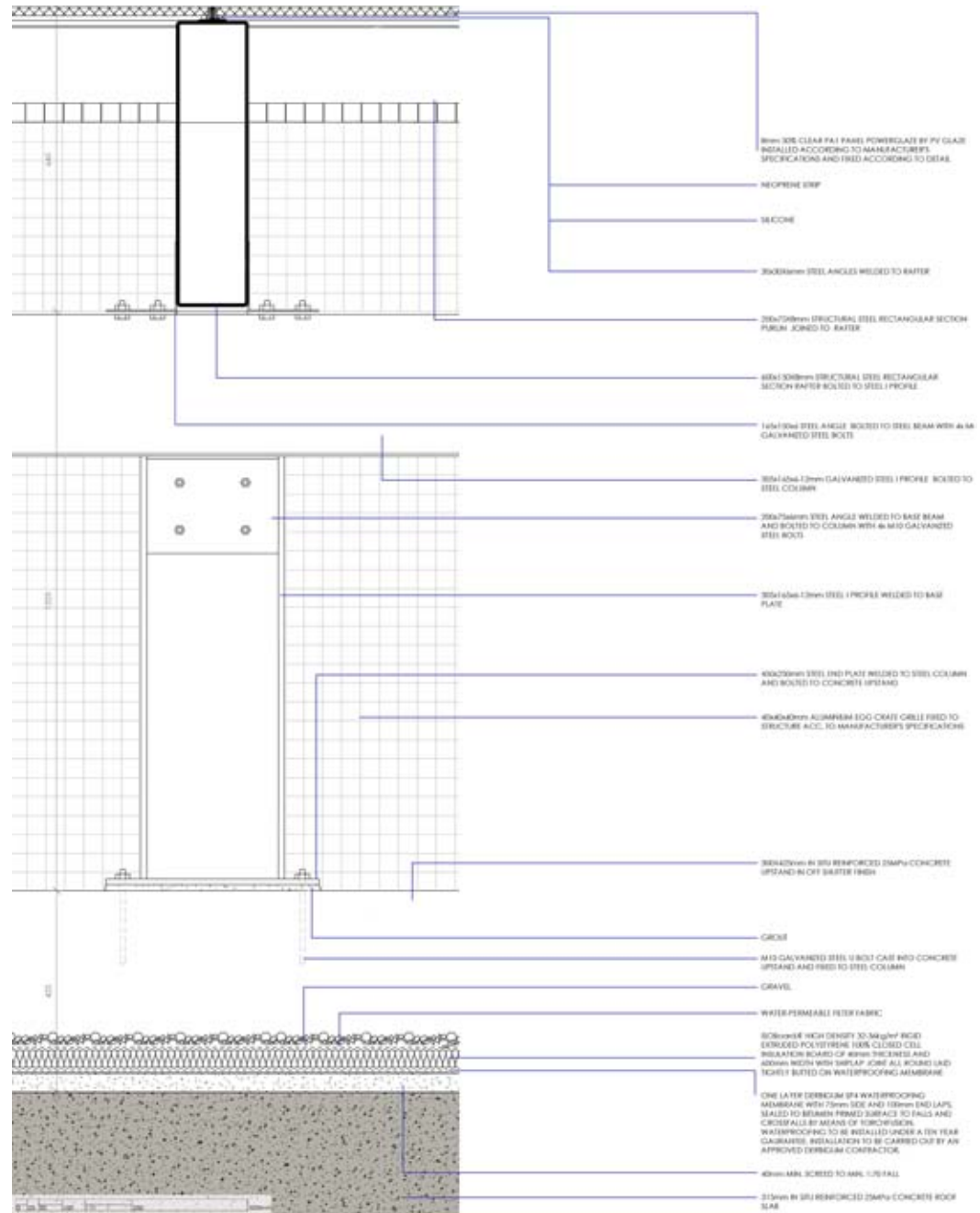

ILLUS. 8.27: Roof detail 1.

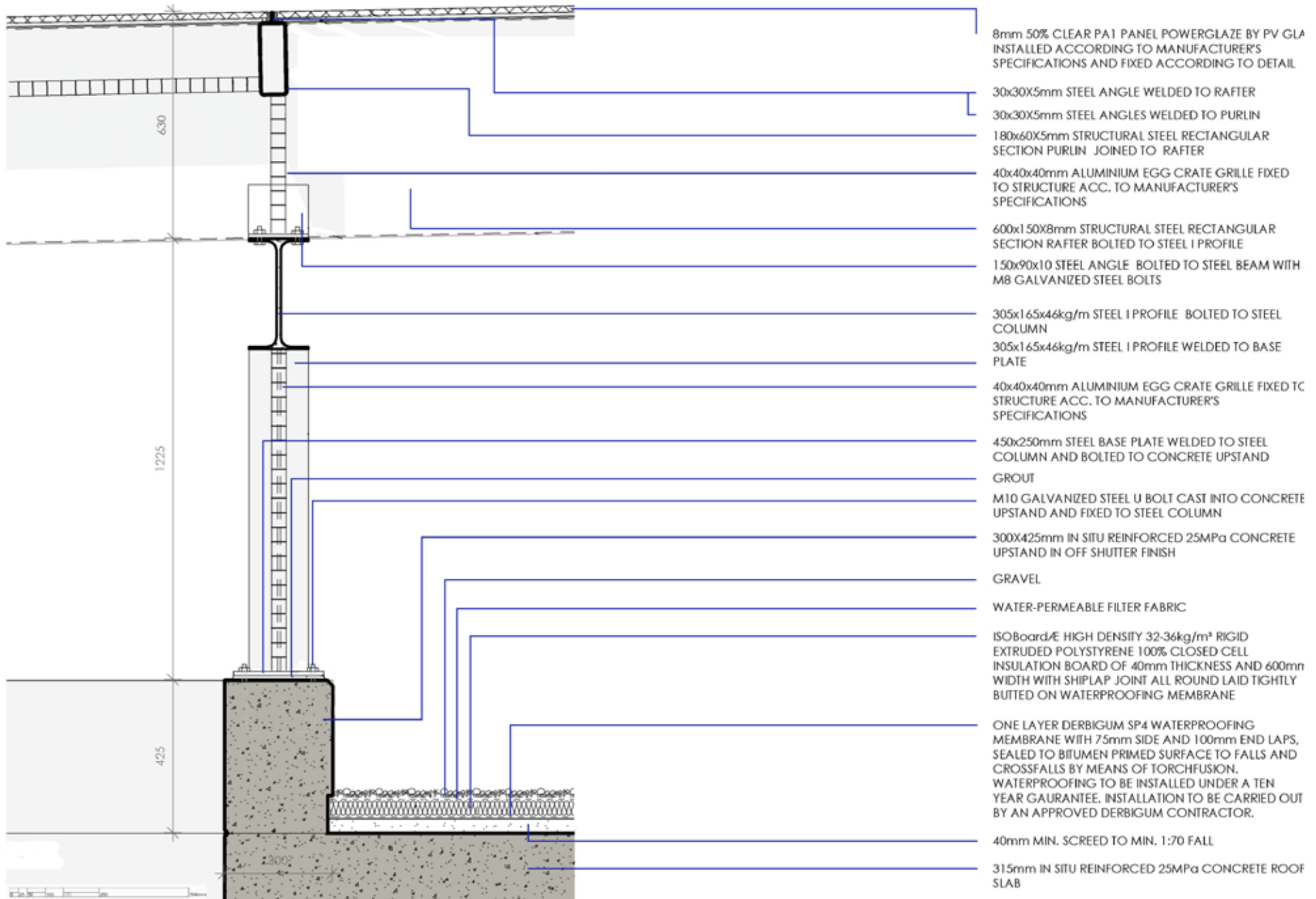

ILLUS. 8.28: Roof detail 2.

8.13 OTHER

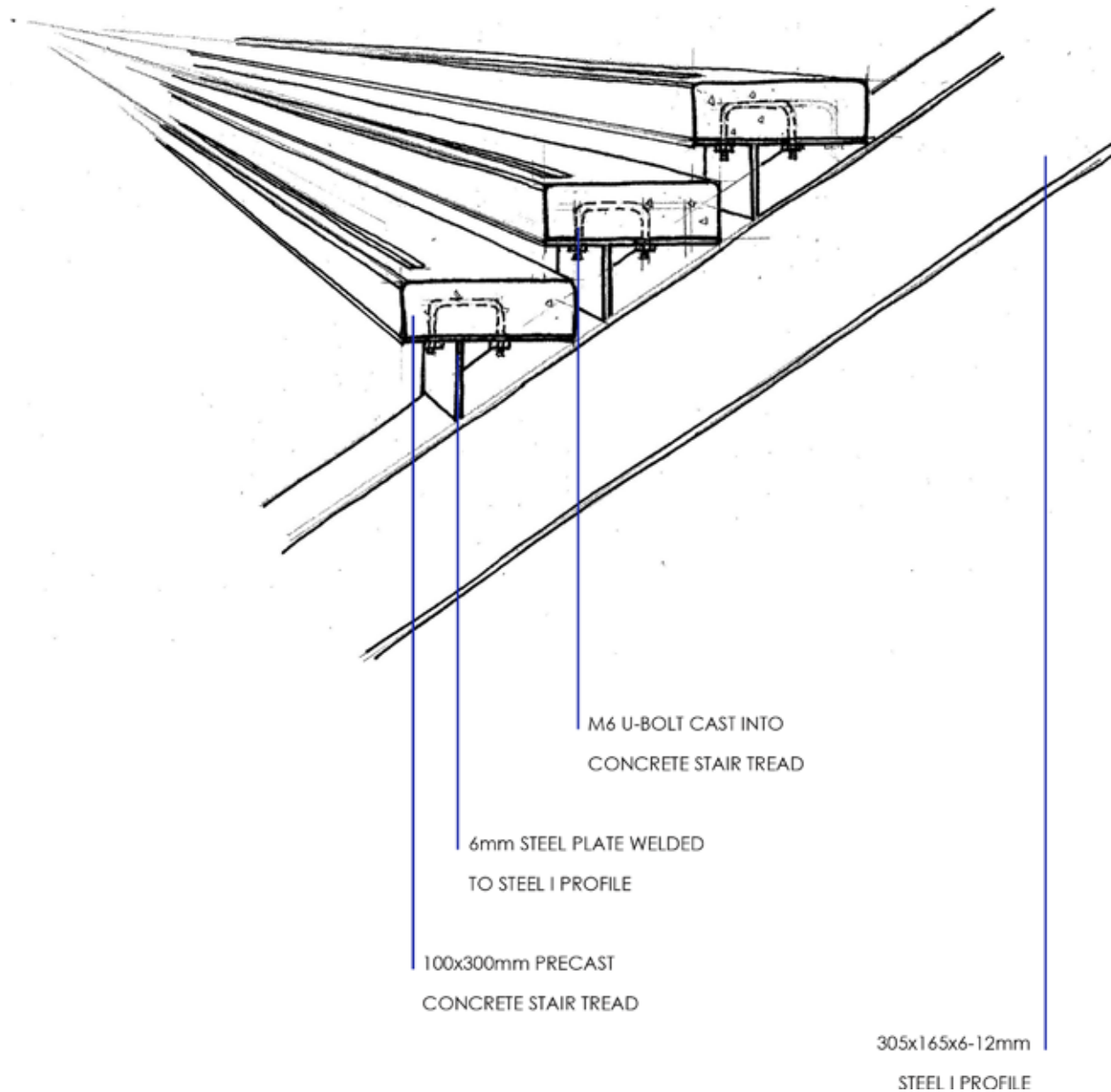

ILLUS. 8.29: Stair detail.

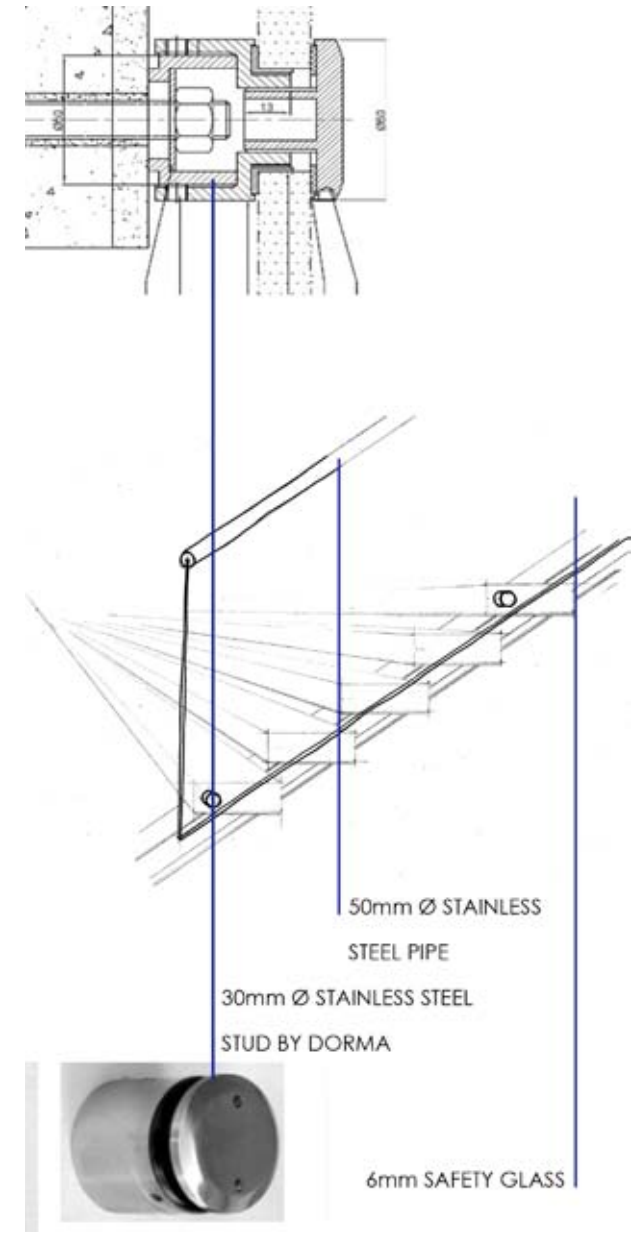

ILLUS. 8.30: Balustrade detail.

8.14 SECTION AA



ILLUS. 8.31: Perspective of section AA.

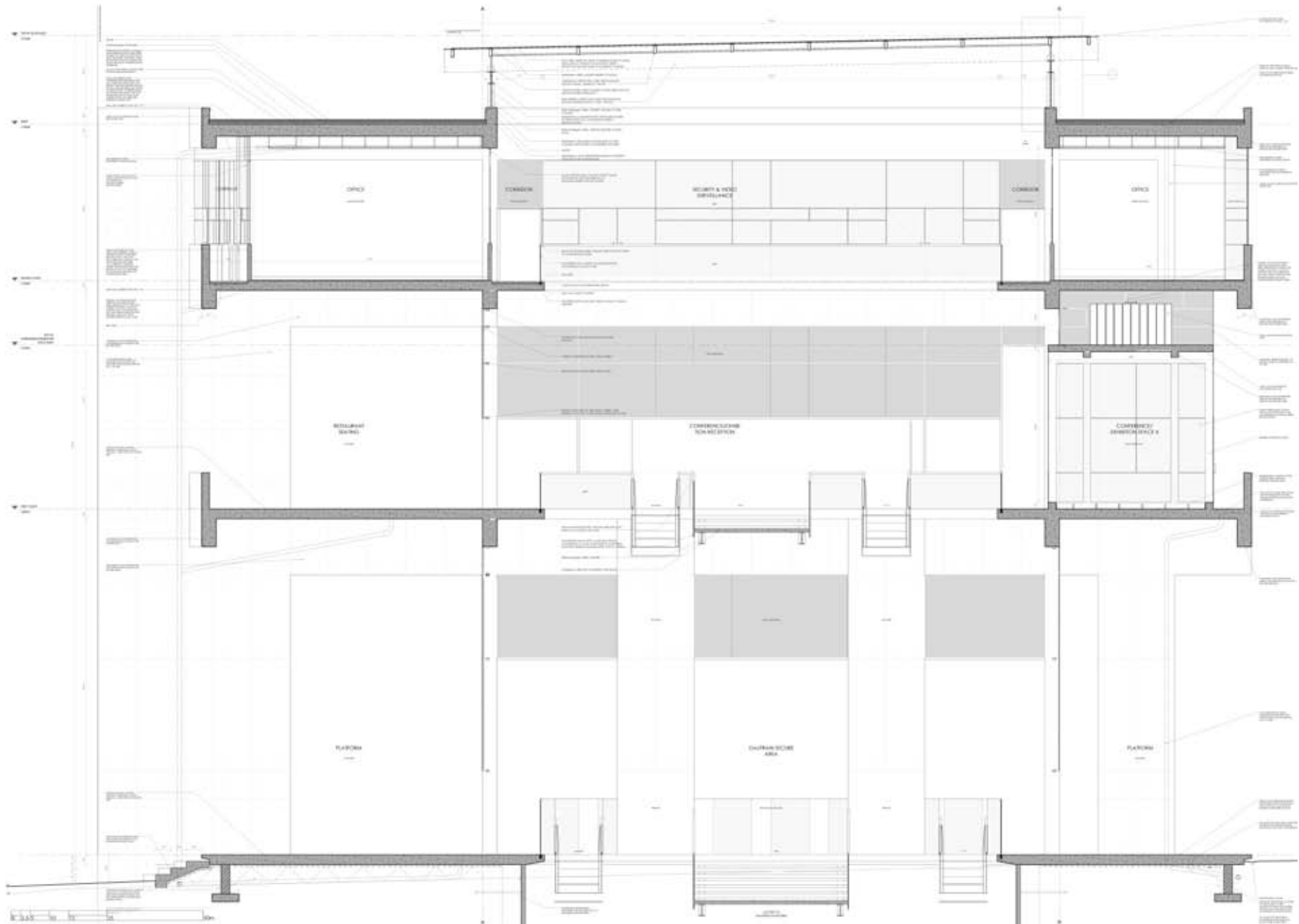

ILLUS. 8.32: Section AA.

8.15 LESSONS I LEARNED AS AN ARCHITECTURE STUDENT

- Making a decision is better than not making one at all.
- When in doubt - dance.
- There will never be enough time, manage what you have.
- Day is for work, night is for sleep.
- People with lives outside of study get more done.
- Your life is only as rich as the people in it.
- Don't buy cheap coffee.
- Design won't save the world, but it can change lives.
- Don't forget why you are doing what you are doing, and do it.
- Backup.

REFERENCES

1. ATASH, F., 1996. Reorienting metropolitan land use and transportation policies in the USA. *Land Use Policy*. 13(1): 37-49.
2. BERRES, T. 2001. *Public Building*. [Online] Available: terrenceberres.com/boyle2b.html [11 October 2011].
3. BOMBELA, 2008. *SFR Specification DD8A-MA Master Architect Role CDE Architectural Guidelines*.
4. BOVILL, C., 1996. *Fractal geometry in architecture and design*. Birkhäuser.
5. BRAINYQUOTE, 2011. *Albert Einstein quotes*. [Online] Available: <http://www.brainyquote.com/quotes/quotes/a/alberteins133991.html> [18 April 2011].
6. CITY PLANNING COMMITTEE. HOUSING, CITY PLANNING, LAND AND ENVIRONMENTAL PLANNING DEPARTMENT, 2002. *Report: discussion on the Pretoria East Mobility Study (phases 1 and 2) and the proposed Menlyn Node Spatial Development Framework*. Pretoria.
7. CITY OF TSHWANE, 2007. *Spatial development framework: Eastern region*. Tshwane.
8. ENGINEERING NEWS, 2007. *Tshwane says work on R1.9bn bus scheme to start next year*. [Online] Available: <http://www.engineeringnews.co.za/article/tshwane-says-work-on-r19bn-bus-scheme-to-start-next-year-2007-08-24> [19 April 2011].
9. EVANS, B., 2005. Action Station. *Architects' Journal*. 221912650: 28-29.
10. FAIRS, M., 2001. Zaha's park-and-ride. *Building (U.K.)*. 226(8185): 40-47.
11. FRAZIER, C. and KOCKELMAN, K.M., 2004. *Chaos theory and transportation systems: An instructive example*. Annual meeting of Transportation Research Board. Washington D.C.
12. GAUTRAIN, 2011a. *Possible future extension*. [Online] Available: www.gautrain.co.za/about/route/stations/background-to-hatfield-station/ [6 May 2011].
13. GAUTRAIN, 2011b. *The Gautrain*. [Online] Available: www.gautrain.co.za/about/about-gautrain/gautrain/ [18 April 2011].
14. GAUTRAIN, 2011c. *Gautrain the stimulus for improved land development*. [Online] Available: www.gautrain.co.za/about/about-gautrain/objectives/gautrain-the-stimulus-for-improved-land-development/ [18 September 2011].
15. GAUTRAIN, 2011d. *Gautrain Station Architectural Design*. [Online] Available: <http://www.gautrain.co.za/about/services/look-feel/gautrain-station-architectural-design/> [23 September 2011].
16. GIOVANNINI, J., 2001. Field of Motion. *Architecture*. 90(9): 136-143.
17. GOODWILL, J., 2002. *Building transit oriented development in established communities*. Center for Urban Transportation Research. University of South Florida.
18. GOVERNMENT GAZETTE, NO. 21493, 23 AUGUST 2000. National Land Transport Transition Act, 2000. South Africa: Government Gazette.
19. GRAAFLAND, A.D. 2007/2008. *Understanding the socius through creative mapping techniques*. Delft School of Design.

20. HERTZOG, T., KRIPNER, R. & LANG, W. 2004. *Facade construction manual*. Birkhäuser.
21. INTERNATIONAL LABOUR ORGANISATION, 2003. *Organising in the taxi industry: The South African experience*. International Labour Organisation, Switzerland.
22. JOYE, Y., 2007. Fractal architecture could be good for you. *Nexus Network Journal*. 9(2): 311-320.
23. LEWIS, C.S., 1942. *A preface to paradise lost*. London: Cumberlege.
24. LYNCH, K., 1975. *The image of the city*. Cambridge: MIT Press.
25. MALLGUIDE.CO.ZA, 2008. *Menlyn Park Shopping Centre*. [Online] Available: www.mallguide.co.za/mall.htm?mallID=97 [6 May 2011].
26. NEWMAN, P.W.G. and KENWORTHY, J.R., 1996. The land use - transportation connection. *Land Use Policy*. 13(1): 1-22.
27. NODECITY.COM, S.a. *Nodecity*. [Online] Available: www.nodecity.com [6 May 2011].
28. NTHOLENG, M., 2010. *Survival guide to Pretoria traffic*. [Online] Available: www.perdeby.co.za/survival-guide-to-pretoria-traffic/ [1 May 2011].
29. ORTON, A. 1987. *The way we build now: Form, scale & technique*. Taylor & Francis.
30. OXFORD DICTIONARIES, 2011. *Fractal*, [Online] Available: <http://www.oxforddictionaries.com/definition/fractal?view=uk> [13 March 2011].
31. OXFORD DICTIONARIES, 2011. *Fracture*, [Online] Available: http://www.oxforddictionaries.com/view/entry/m_en_gb0313600#m_en_gb0313600 [13 March 2011].
32. PARRACK, D., 2010. *100 Most important inventions in history*. [Online] tech.blorge.com/Structure:%20/2010/05/19/100-most-important-inventions-in-history/ [7 May 2011].
33. PIENAAR, A., 2011. Vervoer in SA is nie toeganklik genoeg nie. *Beeld*. 7 Oktober 2011.
34. PORTER, T., 2004. *Archispeak: An illustrated guide to architectural terms*. Taylor & Francis. United Kingdom.
35. PRETORIUS, C., 2011. [Personal communication] *Interview by PRETORIUS, J.* [1 May 2011].
36. PRETORIUS, T., 2000. *Greater Pretoria: Proposed system of realms, nodes and corridors*. South African Transport Conference. South Africa.
37. RAE, G., 2008. *Chaos theory: A brief introduction*. [Online] Available: www.imho.com/grae/chaos/chaos.html [6 February 2011].
38. RASMUS, H., 2001. In praise of the one that got away. *South African Architect*. January-February: 19-21.
39. RASTOGI, N. 2010. *Escalators vs. elevators: what's the greenest way to get to the second floor?* [Online] Available: [How%20much%20energy%20do%20escalators%20use%20-%20Slate%20Magazine.htm](http://www.earthmagazine.com/How%20much%20energy%20do%20escalators%20use%20-%20Slate%20Magazine.htm) [2 October 2011].
40. ROCHA, L., 2003. *Complex systems modelling*. [Online] <http://www.informatics.indiana.edu/rocha/complex/csm.html> [19 April 2011].
41. SALINGAROS, N.A., 2003. *Connecting the fractal city*. Keynote Speech, 5th Biennial of towns and town planners in Europe. Barcelona.
42. SCHOLLES, M., 2001. Sandton Convention Centre: Architect's statement. *South African Architect*. January-February: 22-27.

43. SOUTH AFRICA. DEPARTMENT OF TRANSPORT, 2007. *Key results of the National Household Travel Survey for Gauteng*. Pretoria.
44. SOUTH AFRICA. DEPARTMENT OF TRANSPORT, 2009. *Transport statistics 2008*. Pretoria.
45. THE FRACTORY, 2010. *Fractals and chaos*. [Online] Available: library.thinkquest.org/3288/chaos.html [3 March 2011].
46. THOMPSON, J.W., 1997. Bus Stop. *Landscape Architecture*. 1997(87/10): 110-119.
47. ADVANCED LOGISTICS GROUP, 2008. *Tshwane Bus Rapid Transit (BRT) Operational Report*. Technical report presented by Advanced Logistics Group, 24 April 2008.
48. UITENBOGAARD, A., 2011. *Chaos theory for beginners*. [Online] Available: www.abarim-publications.com/ChaosTheoryIntroduction.html [8 May 2011].
49. VAN DER LAAN, L., 1998. Changing urban systems: An empirical analysis at two spatial levels. *Regional Studies*. 32(3): 325-347.
50. VAN DER SPEK, S.C., 2006. *Optimizing routing and safety for pedestrians*. International Federation of Pedestrians. Zurich.
51. WALKINGINFO.ORG, 2007. *What is jaywalking?* [Online] Available: www.walkinginfo.org/faqs/answer.cfm?id=3469 [1 May 2011].

APPENDIX A

CASE STUDIES & PRECEDENTS

The projects investigated are:

- Bloed Street Mall and Taxi Rank
- Metro Mall transport Facility and Traders Market
- Skinner Street Taxi Rank
- Phillipi Public Transport Interchange

The projects relating to the transportation industry are compared and contrasted. The aspects investigated are:

- Plan
- Circulation
- Facilities provided
- Threshold between taxis and pedestrians

Project Specifics

No. of daily commuters:	25 000
Size of site:	50 000 m ²
No. of taxis:	460
No. of traders:	60
Other:	Fitment centre, wash bays, formal retail



ILLUS. A.1: Entrance to Bloed Street Mall & Taxi Rank.

BLOED STREET MALL AND TAXI RANK

Pretoria CBD. 2008.

Retail Architects International Gauteng.

The Bloed Street Mall and Taxi Rank forms part of the 'We are enhancing Tshwane' project and combines transportation infrastructure with a commercial mall. This approach not only attracts extra users, but renders the project profitable to private investors. The architect describes it as a new archetype, a synergy of first and third world facilities



ILLUS. A.2: Metro Mall Transport Facility.

METRO MALL TRANSPORT FACILITY AND TRADERS MARKET

Johannesburg CBD. 2000.

Urban Solutions Architects and Urban Designers

Part of an urban renewal program of the inner city of Johannesburg. The development serves as gateway to the city and is one of the first public buildings designed for use by the taxi industry. The support of public mobility and the reinforcement and activation of street edges are important to the project.

150 000

26 000 m²

2 000

800

25 bus stops, formal retail



ILLUS. A.3: Philippi Public Transport Interchange.

PHILIPPI PUBLIC TRANSPORT INTERCHANGE

Philippi, Cape Town. 2001.

Du Toit and Perrin in association

The project called for the reinforcement of the public space around Philippi North Station instead of a completely new development. The community were included in the design process which resulted in two public squares. These squares form areas of opportunity for social interaction and remains adaptable for other uses.

30 000

14 000 m²

30

50

Shebeen



ILLUS. A.4: Skinner Street Taxi Rank.

SKINNER STREET TAXI RANK

Pretoria CBD. circa 2000.

Unknown

The Skinner Street Taxi Rank is located on the island of the very busy Skinner Street. This location enables quick and easy access to the site. Ficus trees create an intimate atmosphere and provides shade and shelter. Users of the space have appropriated the raised curbs between taxis lanes and use it for playing games, eating and socialising.

30 000

8 500 m²

120

20

Games

BLOED STREET MALL AND TAXI RANK
 Pretoria CBD. 2008.
 Retail Architects International Gauteng.

KEY

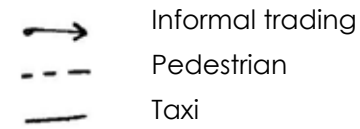

Key similarities of the various projects and trends observed will now be discussed.

A.1 PLAN

The plan refers to the functional layout of the site.

- Taxi ranking areas are placed in the centre of the site.
- As the project places stronger emphasis on a less formal functionality, the layout of the taxi rank is more responsive to vehicular flow and less dictated by the structure of the housing facility.

A.2 CIRCULATION

Circulation describes the movement of vehicles and pedestrians within the site.

- Conflict arises where the circulation paths of taxis and pedestrians cross.
- Informal trading does not necessarily take place where intended by the designer, but rather coincides with areas of high pedestrian movement.

ILLUS. A.5: Bloed Street Mall and Taxi Rank lower ground floor sketch plan and circulation plan.

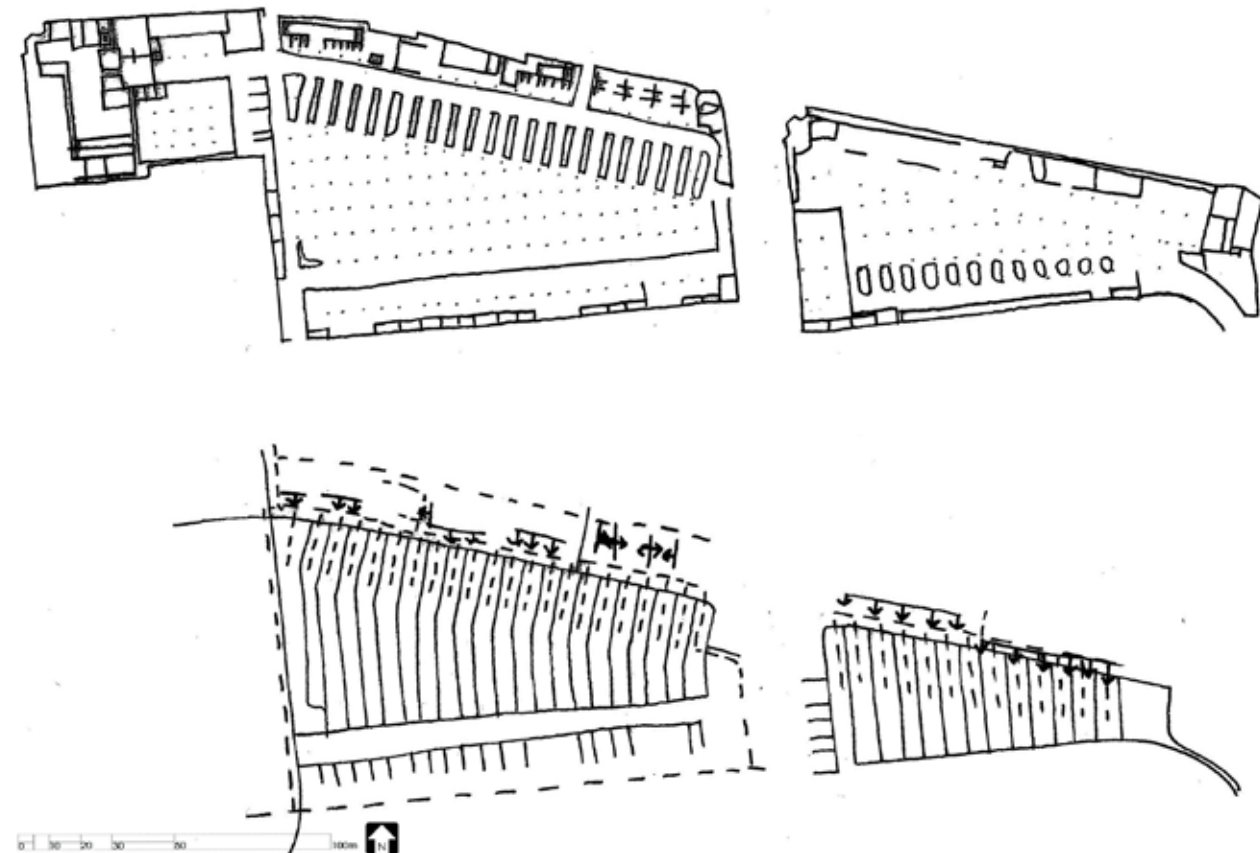

METRO MALL TRANSPORT FACILITY AND TRADERS MARKET

Johannesburg CBD. 2000.

Urban Solutions Architects and Urban Designers

ILLUS. A.6: Metro Mall Transport Facility and Traders Market ground floor sketch plan and circulation plan.

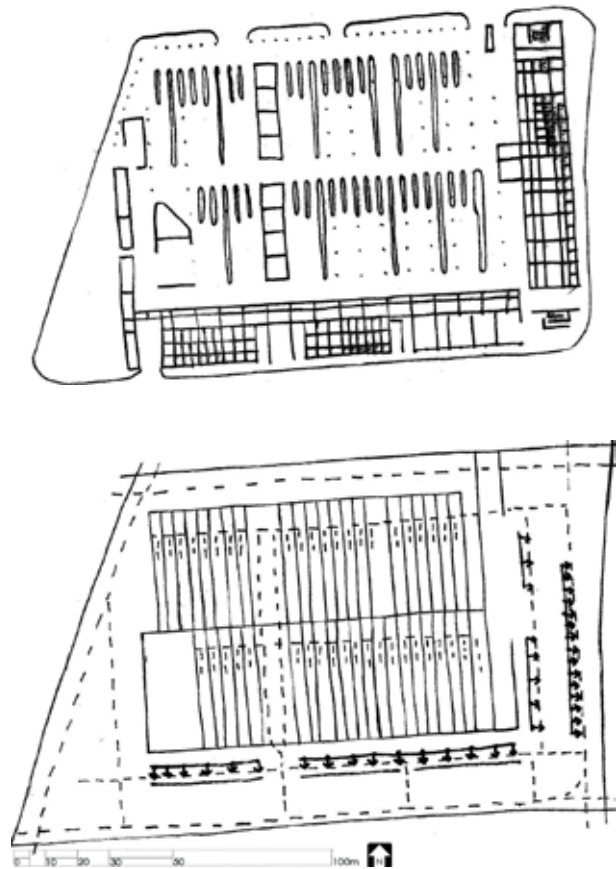

PHILIPPI PUBLIC TRANSPORT INTERCHANGE

Philippi, Cape Town. 2001.

Du Toit and Perrin in association

ILLUS. A.7: Philippi Public Transport Interchange site sketch plan and circulation plan.

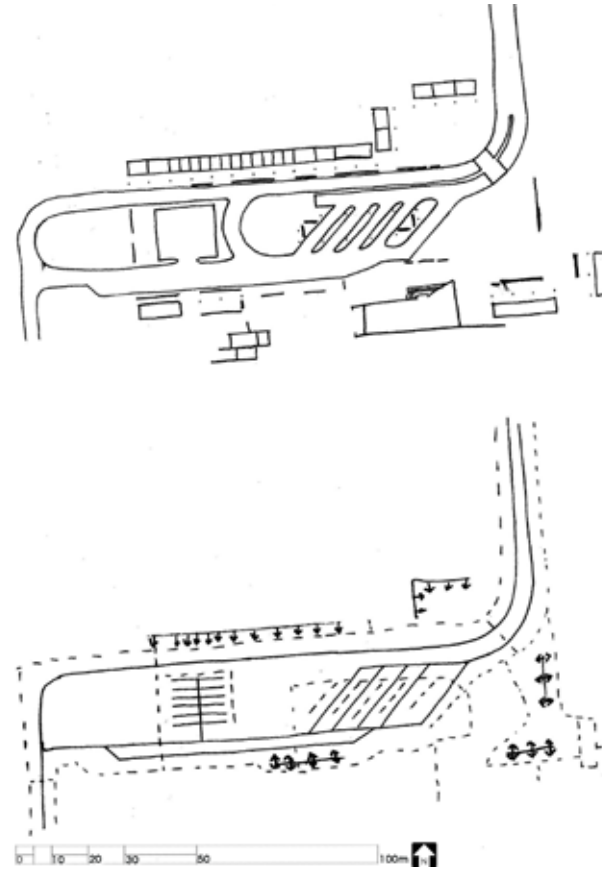

SKINNER STREET TAXI RANK

Pretoria CBD. circa 2000.

Unknown

ILLUS. A.8: Skinner Street Taxi Rank site sketch plan and circulation plan.

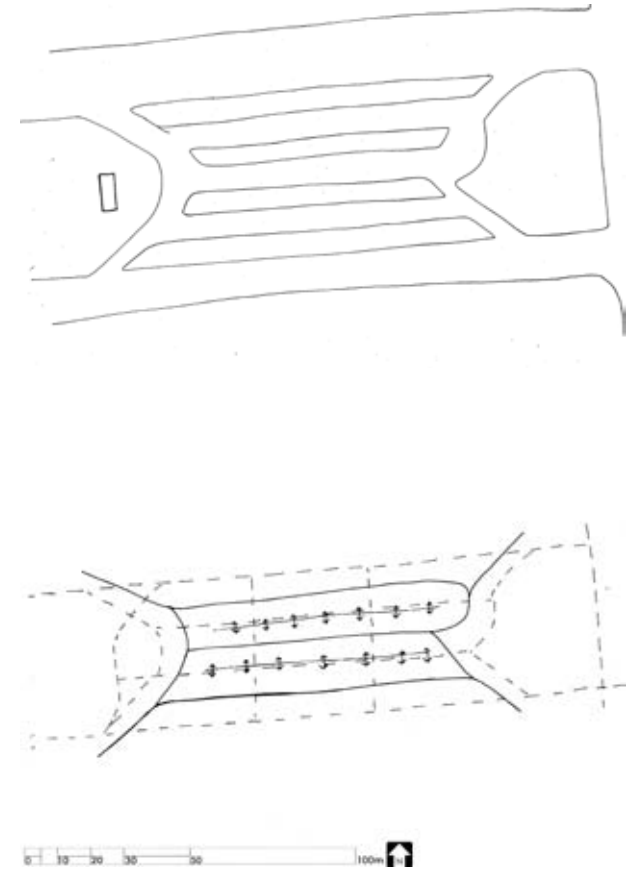

BLOED STREET MALL AND TAXI RANK
 Pretoria CBD. 2008.
 Retail Architects International Gauteng.

ILLUS. A.9: Facilities and section of interface at Bloed Street Mall and Taxi Rank.

A.3 FACILITIES PROVIDED

This list covers the set of essential facilities and services.

- Taxi ranking areas
- Shelter (structural and trees)
- Wash bays
- Storage
- Surfaces for selling, seating, eating
- Ablution
- Food

A.4 INTERFACE BETWEEN TAXIS AND PEDESTRIANS

- Traders are present at the pedestrian/vehicular interface.
- Safety of pedestrians should be taken into account
- Outdoor: Trees provide a pleasant environment for interaction and shelter.
- A high floor-to-ceiling-height is preferable.

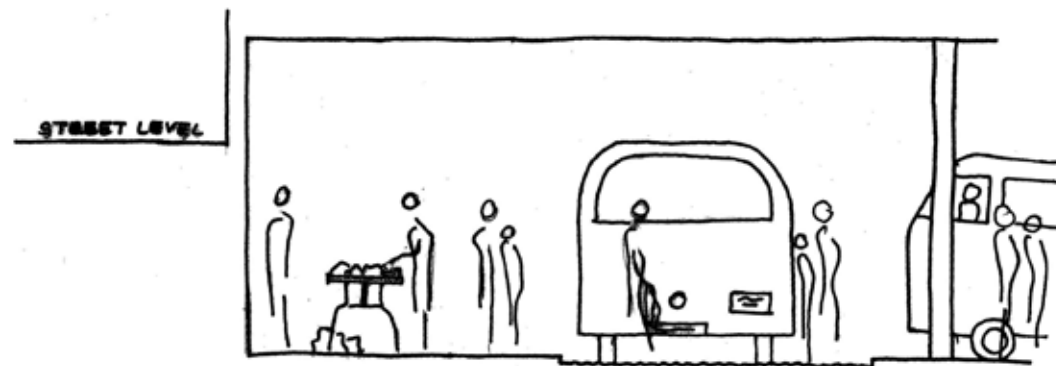
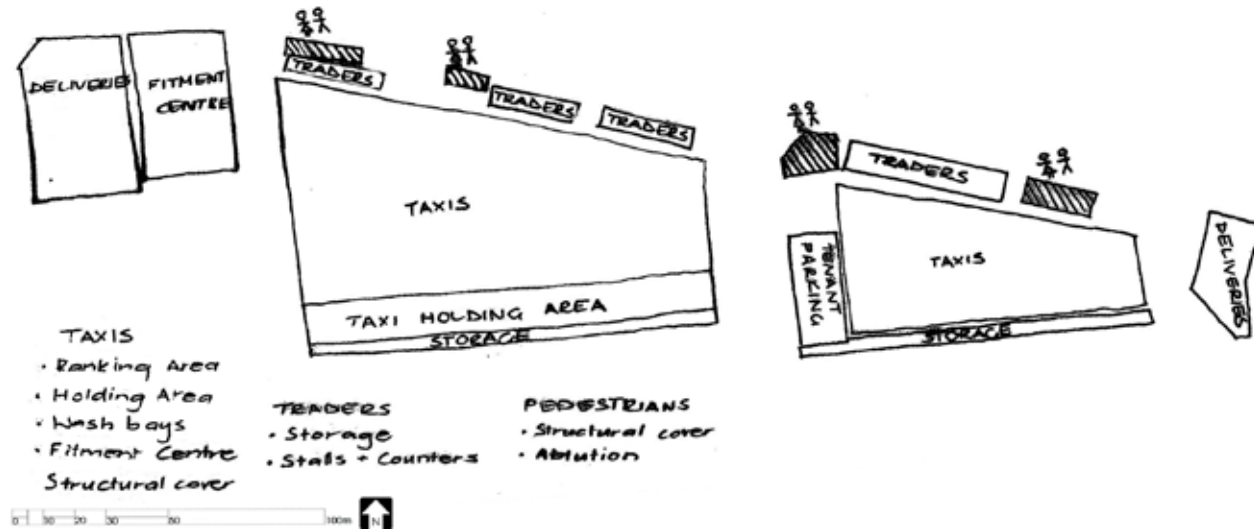

METRO MALL TRANSPORT FACILITY AND TRADERS MARKET

Johannesburg CBD. 2000.

Urban Solutions Architects and Urban Designers

ILLUS. A.10: Facilities and section of interface at Metro Mall Transport Facility and Traders Market.

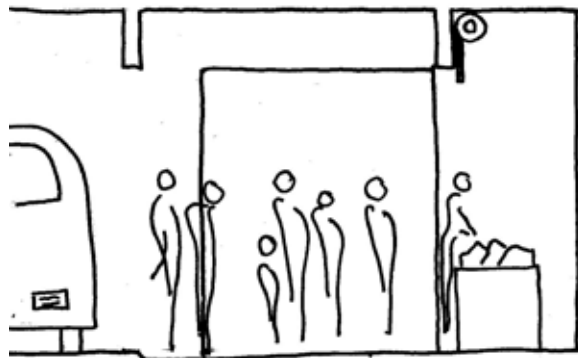
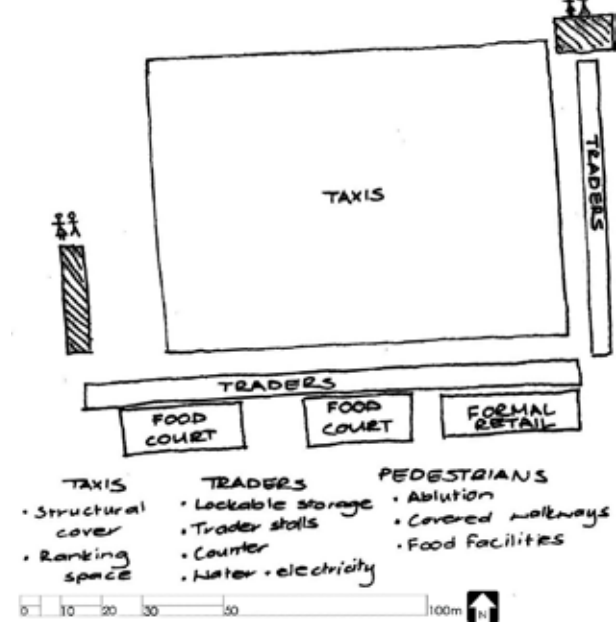

PHILIPPI PUBLIC TRANSPORT INTERCHANGE

Philippi, Cape Town. 2001.

Du Toit and Perrin in association

ILLUS. A.11: Facilities and section of interface at Philippi Public Transport Interchange.

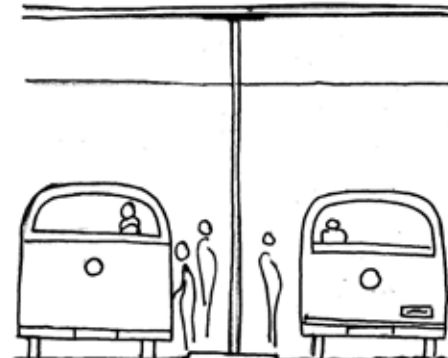
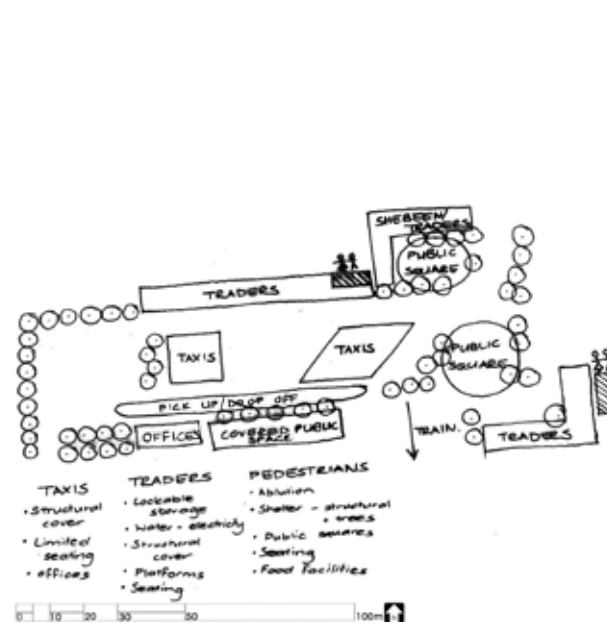

SKINNER STREET TAXI RANK

Pretoria CBD. circa 2000.

Unknown

ILLUS. A.12: Facilities and section of interface at Skinner Street Taxi Rank.

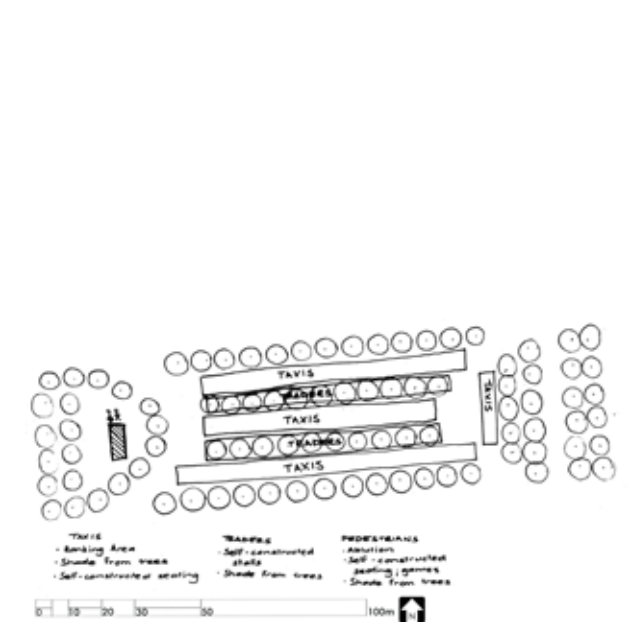

APPENDIX B

CALCULATIONS

B.1 STRUCTURAL CALCULATIONS

according to Orton (1987: 30 - 54)

B.1.1 CONCRETE COLUMN

Cast-in-situ multistorey column

Height (h) = 4 - 9m

Depth (d) = 750mm

Typical h/d = 6 - 15

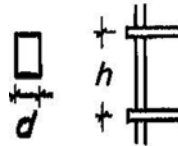

ILLUS. B.1: Illustration of structural column.

$L/d = 9\ 000/750$

= 12

B.1.2 CONCRETE FLOOR

Reinforced two-way slab

Span (L) = 5 - 7.5m

Depth (d) = 255mm

Typical L/d = 28 - 35

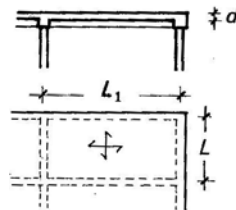

ILLUS. B.2: Illustration of reinforced two-way slab.

$L/d = 7\ 500/255$

= 29

B.1.3 CONCRETE ROOF

Reinforced one-way solid slab

Span (L) = 5 - 7.5m

Depth (d) = 315mm

Typical L/d = 20 - 30

$L/d = 7\ 500/315$

= 23

B.1.4 STEEL COLUMN

Single storey rolled steel of open section

Height (h) = 0.6 - 1m

Depth (d) = 165mm

Typical h/d = 20 - 25

$L/d = 1\ 000/165$

= 6 - oversized

Element is oversized to adequately support other roof elements and adhere to design

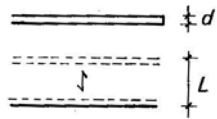

ILLUS. B.3: Illustration of reinforced one-way solid slab.

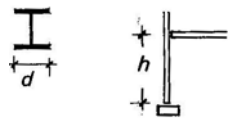

ILLUS. B.4: Illustration of steel column.

principles.

B.1.5 STEEL ROOF

Wide flange rolled steel section

Span (L) = 9.25m; 15m; 1.5m

Depth (d) = 305mm; 600mm; 200mm

Typical h/d = 20 - 30

$$\begin{aligned} L/d &= 9\ 250/305 \\ &= 30 \end{aligned}$$

$$\begin{aligned} L/d &= 15\ 000/600 \\ &= 25 \end{aligned}$$

$$\begin{aligned} L/d &= 1540/200 \\ &= 7.7 - \text{oversized} \end{aligned}$$

Element is oversized to adequately support other roof elements and adhere to design principles.

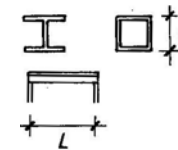

ILLUS. B.5: Illustration of steel roof.

B.2 WATER RUN-OFF AND SANITARY REQUIREMENT CALCULATIONS

B.2.1 Sanitary requirements
according to NBR SANS 0400

TABLE B.1: Sanitary requirements.

	Male			Female	
	WC	U	WHB	WC	WHB
PUBLIC AREAS - Table 7					
Population - 3 000	7	20	8	30	12
OFFICES – Table 6					
Population - 60	2	3	3	5	3

B.2.2 Rainwater budget
population 3000
wc = 3000 x 3ℓ (per flush)
= 9000ℓ per day

B.2.3 Water storage tank calculations

9000ℓ per day population 3000

	JAN	FEB	MAR	APR	MAY	JUN	JUL	AUG	SEP	OCT	NOV	DEC
AVERAGE MONTHLY RAIN (mm)	136	75	82	51	13	7	3	6	22	71	98	110
RUN-OFF (ℓ)	114 704	62 488	68 480	41 944	9 416	4 280	856	3 424	17 120	59 064	82 176	92 448
Vt (ℓ)	-164 296	-189 512	-210 520	-188 056	-269 584	-265 720	-278 144	-275 576	-252 880	-219 936	-187 824	186 552
DEMAND (ℓ)	279 000	252 000	279 000	270 000	279 000	270 000	279 000	279 000	270 000	279 000	270 000	279 000
OVERFLOW (ℓ)	0	0	0	0	0	0	0	0	0	0	0	0

Maximum average rainfall per day = $114\,704/31$
 = 3700ℓ

8 x 2500ℓ Jojo rainwater storage tanks
 = 20 000ℓ
 = 5 days max. av. rainfall per day
 = 2 day water supply



TABLE B.2: Water storage tank calculations.
 ILLUS. B.6: 2 500ℓ Horizontal Jojo water storage tank.

APPENDIX C

VEGETATION



ILLUS. C.1: Erythrina lysistemon.



ILLUS. C.2: Harpephyllum caffrum.

TREE SPECIES

NAME:	Erythrina lysistemon (Coral tree)	Harpephyllum caffrum (Wild plum)
HEIGHT:	8m	12m
DIAMETER:	8m	11m
SHAPE:	Round, open shape	Rectangular, dense shape
DECIDUOUS/EVERGREEN:	Deciduous	Evergreen
USE:	Medicinal	Lemonade, jam
OTHER:	Half hardy, full sun, aggressive root system	Wind hardy, half hardy, full sun to semi shade



ILLUS. C.3: Syzygium Cordatum.



ILLUS. C.4: Euclea Crispa subsp.



ILLUS. C.5: Heteropyxis Natalensis.

Syzygium Cordatum (Waterberry)

11m

8m

Round, dense shape

Evergreen

Jelly, liquor

Half hardy, full sun, aggressive root system

Euclea Crispa Subsp (Blue Guarri)

6m

5m

Round, dense shape with long trunk

Evergreen

Medicinal, edible fruit

Hardy, full sun

Heteropyxis Natalensis (Lavender Tree)

10m

8m

Round, dense shape

Deciduous

Medicinal

Half hardy

APPENDIX D

OTHER

D.1 NEWSPAPER ARTICLE

VERVOER IN SA IS NIE TOEGANKLIK GENOEG NIE (Pienaar, A. 2011).

Minstens 40% van Suid-Afrikaners sukkel om toegang te kry tot openbare vervoer omdat hulle fisiek gestrem is of in 'n lewenstadium is waar iets soos swangerskap hul beweeglikheid inperk.

Mnr. Jeremy Cronin, adjunkminister van vervoer, het gister by 'n kongres vir gestremdes in Sandton gesê sowat 2,4 miljoen passasiers op die land se openbare vervoerstelsel is gestrem, maar nog sowat 20 miljoen is beperk omdat hulle bejaard of swanger is of sukkel met stootwaentjies en kinders wat saam op busse en treine moet reis.

Cronin het gesê die Suid-Afrikaanse openbare vervoerstelsel is selfs vir nie-gestremdes duur en ontoeganklik.

Net sowat 31% van huishoudings het toegang tot 'n motor. Minstens 30% van huishoudings bestee 11% of meer van hul huishoudelike inkomste aan openbare vervoer en 18% bestee meer as 20%.

Cronin het voorts gesê 40% van die 14 000 mense wat jaarliks op die paaie sterf, is voetgangers.

Hy meen die manier hoe stede beplan is, is een van die oorsake vir die swak toegang wat veral gestremdes het tot openbare vervoer.

Volgens Cronin het die wit middelklas ver uit stede gestrek na veiligheidsdorpe en is

afhanklik van motors en leef in winkelsentrums.

Ontwikkelaars het die uitbreiding gedryf pleks dat die regering dit met behoorlike stadsbeplanning bepaal het. Hy het gesê die gemiddelde reis op openbare vervoer in die Tshwane-streek is 25,4km lank. In Londen is dit 8.6km en in Moskou 7.7km,

D.2 SUSTAINABLE BUILDING ASSESSMENT TOOL (SBAT)

SUSTAINABLE BUILDING ASSESSMENT TOOL (SBAT- P) V1

PROJECT		ASSESSMENT	
Project title:	Platform Building at Menlyn	Date:	Oct-11
Location:	Menlyn	Undertaken by:	Jané Pretorius
Building type:	Public	Company / organisation:	University of Pretoria
Internal area (m2):	10 000	Telephone:	Fax:
Number of users:	20 000 per day	Email:	

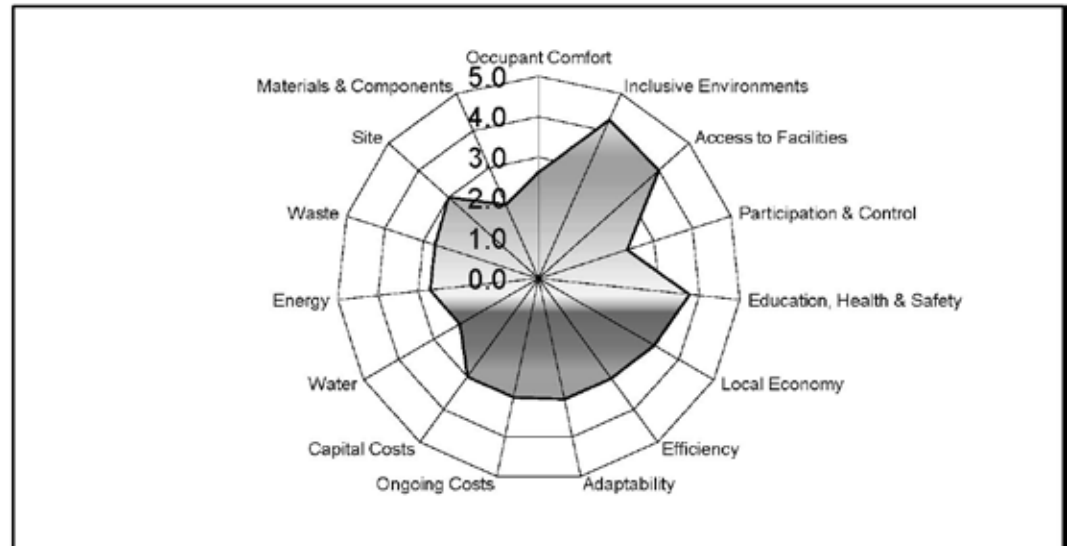

Social	3.4	Economic	3.1	Environmental	2.5
Overall	3.0	Classification	Good		

ILLUS. D.1: Results of SBAT applied to Platform Building.

D.3 MODEL



ILLUS. D.2: View from North East corner.

ILLUS. D.3: Southern side of model.



ILLUS. D.4: Approach from South.



ILLUS. D.5: Aerial view of model.

