

# design *discourse*

## A MODERN DESIGN PREMISE

The strong modern heritage of the Berrals building required recognition in the proposed intervention. A study of modern principles and its regional mutations became paramount in determining a suitable design intervention. The study functions as a tool to determine which components of the Berrals, as a modern icon, requires preserving, as well as what the design approach will need to consider in terms of interacting with the existing modern structure.



# modern design *premise*

## PRINCIPLES OF MODERN DESIGN



Fig. 7.1. *Les Femmes d'Alger* (1907) by Pablo Picasso



Fig. 7.2. *Woman with a guitar* (1913) by Georges Braque

In the 1920's a new architectural language known as the 'International Style' was emerging and projects around the world were adopting this new style and its aspirations. The style revolted against the prevailing tendency of creating a building as a block and decorating the external enclosure with ornament. The new movement stripped the building of its ornament and focused more on the three-dimensional exploration of the volumetric intricacies within the architectural space (Chami 2007:1).

The towering genius of this movement was one of the founders of the Congrès Internationaux d'Architecture Moderne, (CIAM), Charles-Edouard Jeanneret (1887-1966), better known as Le Corbusier. He contributed as a writer, painter, architect and town-planner, and is regarded as the most pervasive influence on modern architecture, for good or ill (Nuttgens 1998:267). An understanding of his work is indispensable to acquire an understanding of modern architecture and an inclusion of his thoughts and projects as references in the study provide a clear perspective on modern design principles.

### Basic Architectural Elements

In the years before the First World War, the development of Cubism and Futurism in the art

world, significantly influenced modern thinking. The paintings of both Picasso and Braque had begun to portray people and objects in such a way that several sides of the model, animate or inanimate, were visible simultaneously. In Futurist sculpture and painting, the concept of movement became paramount: objects and figures were shown not in a single, static position, but while in motion.

To Le Corbusier this awareness meant the possibility of exploring a new and different kind of space. A space not divided into cubicles, not statically contained within four walls, a floor and a roof, but a space, experienced simultaneously from without and within. A space seen by the observer passing through, rather than from a frozen spot in the total composition, a dynamic spatial experience.

Though the spatial discoveries made by the Cubists and Futurists inspired Le Corbusier, he argued against their decorative tendencies. Amédée Ozenfant, an established French painter, shared these views and together they developed an artistic theory which became known as Purism. Purism as a form of Cubism, wanted a return to more basic forms. Ozenfant and Le Corbusier advocated this use of primary forms and colours (fig. 7.1), and insisted that objects depicted in paintings should have

Fig. 7.3. *Nature morte a la pile d'assiettes* (1920) one of the purist painting done by Le Corbusier



significance beyond their utilitarian function. They searched for a means by which an aesthetic language could communicate universally.

From an architectural point of view, Le Corbusier translated this idea into three basic elements: volumes, surfaces and plans. He writes: "Volumes and surfaces are the elements through which architecture is made visible. Volumes and surfaces are determined by the plan. The plan is the generator. So much the worse for those who lack imagination!" (Guiton 1981:37).

This statement captures Le Corbusier's Purist perception of space. He writes about these elements, giving insight into each of them individually:

**1. Volumes:** "Architecture is the skillful, exact, and magnificent play of volumes assembled in light. Our eyes are designed to see forms in light; shadow and light reveal forms; cubes, cones, spheres, cylinders, and pyramids are the great primary forms so well revealed by light; their image is exact and tangible, free of all ambiguities. This is why they are beautiful, the most beautiful forms." (Guiton 1981:37)

**2. Surface:** "Since architecture is the skillful, exact, and magnificent play of volumes assembled in light, the architect must bring the surface that envelops these volumes to life, without letting them become parasites that devour the volumes by assimilating them to their

own ends, as has been the story of present times. If we are to let a volume retain the splendour of its form in light but at the same time adapt the surface to functional tasks, we shall have to find, in the necessary subdivisions of the surfaces, such elements that will 'accentuate', & 'generate', the form. In other words, an architectural work may be a house, a temple, or a factory, but the surface in all are generally a wall pierced with doors and windows; these openings, which often destroy the form, must be made to accentuate the form. Since architecture consists fundamentally of spheres, cones, and cylinders, the elements that generate and accentuate these forms will be based on pure geometry." (Guiton 1981:37-38)

**3. Plans:** "The plan is the generator... The spectator's eye moves through a site made of the volumes that rise up around it. If these volumes are forms that have not been debased by inappropriate alterations, if their grouping expresses a clear rhythm, not an incoherent cacophony, if the proportions between the volumes and the intervening spaces are correct, the eye will transmit to the brain coordinated sensations that are intensely pleasing to the mind: this is architecture.

Inside, the eye perceives the multiple surfaces of walls and vaults. The cupolas determine spaces; the vaults unfold surfaces; the columns and the walls interact intelligibly with one another. The whole structure rises from its base and follows a rule that is inscribed on the

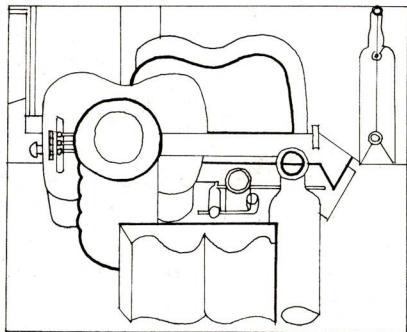

Fig. 7.4. A line drawing of the painting *Nature morte a la pile d'assiettes*

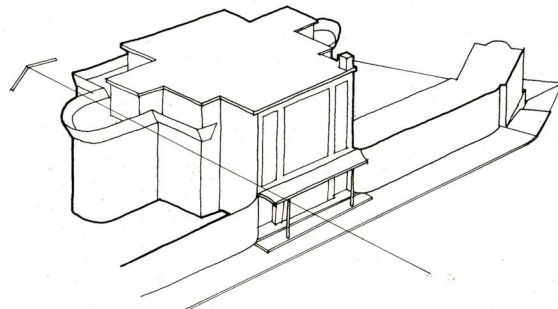

Fig. 7.5. A three-dimensional expression of Purism found in architectural elements

*ground, in the plan: beautiful forms, many varieties of forms, a unifying geometric principle. A profound sense of harmony prevails: this is architecture.*

*The plan is basic. Where there is no plan, there is no greatness of intention and expression, no rhythm, no volume, no coherence. Where there is no plan, we experience that sensation of formlessness, indigence, disorder, unreason, that the human mind can not endure.*

*The plan calls for a highly active imagination. It also calls for severe self-discipline. The plan determines everything else; it is the decisive moment!" (Guiton 1981:38)*

It is important to note that Le Corbusier suggests (Guiton 1981:38) that we must never forget that this two-dimensional plan, which can be read in a single glance, describes three-dimensional volumes that will be seen successively: *"Architecture can be seen only by a 'walking' man... so much so that when it comes to the test, buildings can be classified as alive or dead according to whether the rule of 'movement' has been applied or not. As Arab architecture shows, we can not understand the development of an architectural composition unless we are walking, moving from one place to another."*

## Two Dwelling Types

Le Corbusier's early spatial exploration led to the development of two basic dwelling types, the Maison Domino, first published in 1914, and

Maison Citrohan, developed during 1919-1927.

Essentially the difference between the two models lies in the use of the frame. In Maison Citrohan, it merely raises the house off the ground, confining the frame to the walls, with no spatial role, whereas in the Maison Domino, the frame has spatial consequences (fig. 6).

Experiments during the twenties with both these models led Le Corbusier to the formulation of the 'Five Points of a New Architecture', recognised as the basic principles of modern architecture.

### Maison Domino

In Maison Domino there exists a horizontal spatial potential which emerged from the sophisticated concrete technology which had been developed in France by Freysinetr, Perret etc.

It was a simple statement about the possibilities of reinforced concrete construction: a frame of six columns, supporting all floor and roof slabs, with a cantilever stair linking the different levels to the ground and to the roof. These structural elements were the only fixed parts of the house, everything else was nonstructural and hence entirely flexible. It was a clear and convincing statement of the 'free plan', a plan freed from the need of load-bearing walls and hence capable of infinite compositional variations within the same structural system.

Fig. 7.6. A three-dimensional model of the Domino Prototype

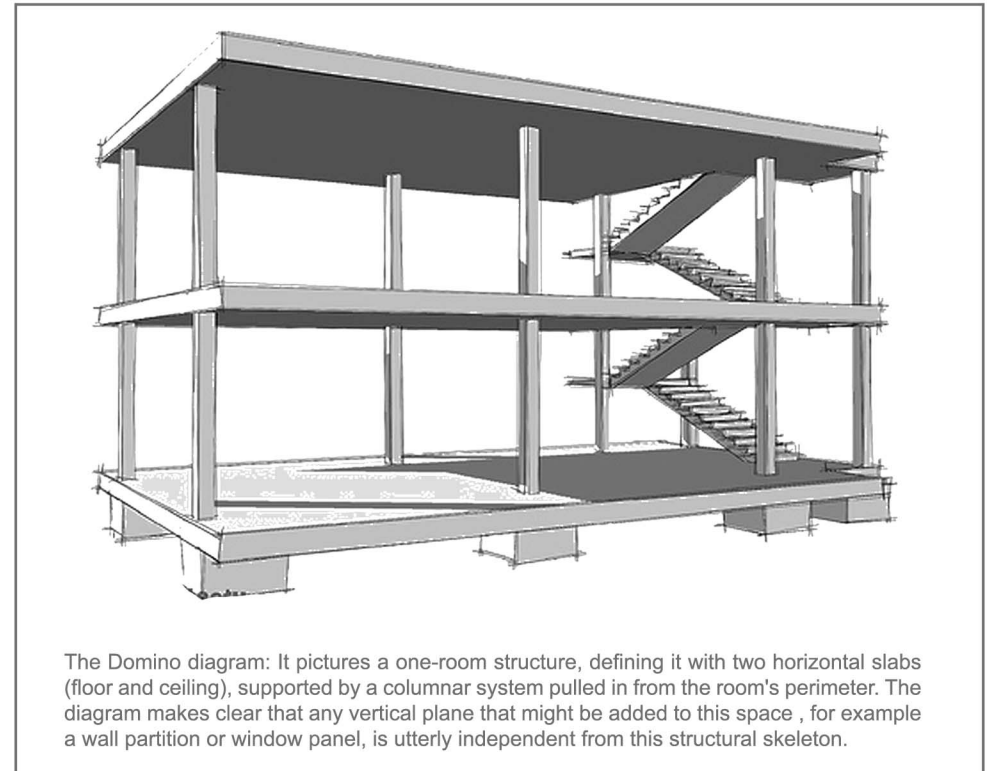

## Maison Citrohan

Maison Citrohan, on the other hand, is a model that had a closed, vertical orientation. It was intended as a model that could be built anywhere and it comprised of masonry side walls that is easy to construct, floors and a roof of reinforced concrete and a purist spatial composition. Various models were developed, the first in 1919, and the final one in 1927.

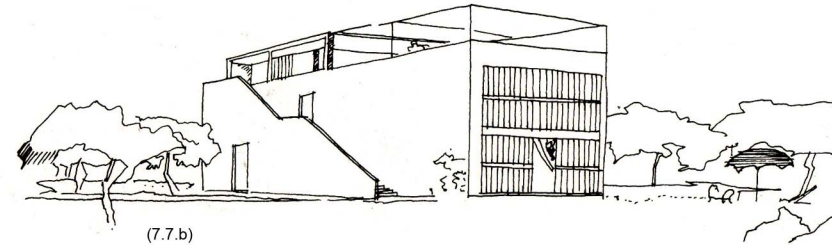
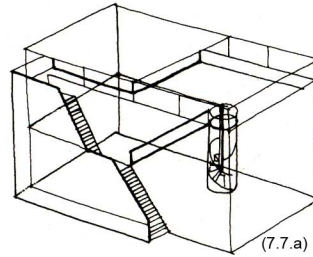

Fig. 7. a &amp; b. 1920 Citrohan Model

Le Corbusier's compositional breakthrough in Purism received architectural expression in the 1920 Maison Citrohan, where the solids (cellular units), the cylinder (spiral stair) and various planes are deployed in a state of dynamic equilibrium, resembling in the third dimension the two dimensional technique used in paintings (fig. 7.4 & 7.5).

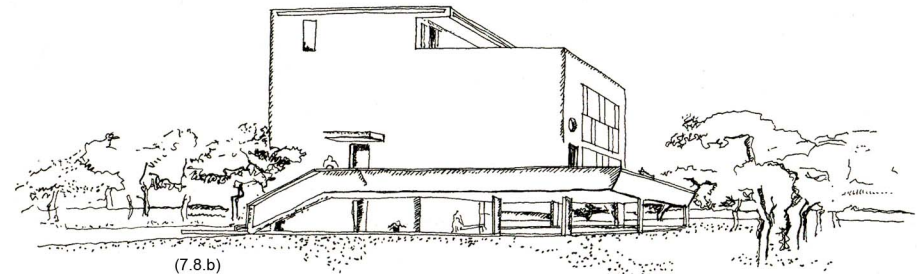
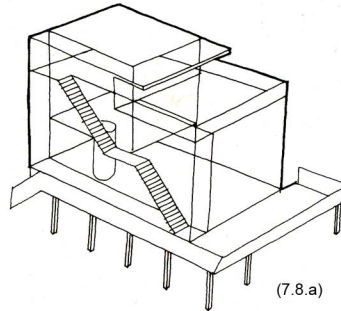

Fig. 8. a &amp; b. 1922 Citrohan Model

The modified 1922 Maison Citrohan included a garage as an integral part of the concept. The garage is placed below the house which is raised by means of a framed structure and the main stair is moved inside.

The final version of the Citrohan models was built as one of Le Corbusier's contributions to the Weissenhof housing exhibition at Stuttgart in 1927 and this model retained the best features from all the earlier designs. The main stair is enclosed, the roof terrace is kept and a frame construction raises the house on pilotis allowing a garage to be placed at ground level.

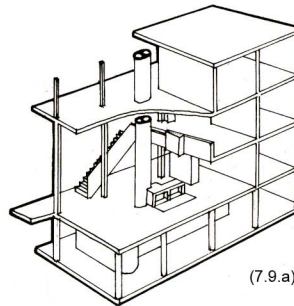

Fig. 9. a &amp; b. 1927 Citrohan Model

## The Five Points of a New Architecture

Le Corbusier's studies with the various models led him to the development of five basic elements to guide modern architectural design.

In his first book 'Ver une architecture' (1923), translated into English under the title 'Towards a New Architecture' (1927), Le Corbusier announced the 'five points of a new architecture', derived from the potentials of the concrete frame.

In order of their appearance in the book they are:

1. **The Column** (*les pilotis*): designed to raise the building off the ground and thus free the site. It permits circulation and the continuation of the garden under and through the building;
2. **The Roof-Garden** (*les toits-jardins*): the consequence of a flat roof, used as a garden terrace to bring the landscape into the house. Worth mentioning, is that Le Corbusier acknowledged the roof-garden as an interior space;
3. **The Free Plan** (*le plan libre*): a plan unencumbered by structural partitions, using a frame construction to free the plan from load-bearing walls to flow according to function and aesthetics (Domino);
4. **The Ribbon Window** (*la fenêtre en longueur*): to create maximum illumination;
5. **The Free Façade** (*la façade libre*): the

corollary of the free plan in the vertical plane.

The 'free plan' is usually taken as the focal point of the five points, introducing what was an essentially new architecture, one which develops from the inside towards the outside. The column, point one, and the uninterrupted floor slab are the constructional premises for this free plan: it is the function that gives form to the interior space.

In the break down of the five points, the position of the roof-garden as point two seems peculiar, as it appears to be a subordinate point to that of point one, the column, and point three, the free plan. The question is thus raised whether the roof-garden is more than just a functional suggestion for the top or a digestion of impressions of the architecture of the Middle-East?

In the book 'Runplan versus Plan Libre', Arjan Hebly (1988:47) explains that the place of the roof-garden in the structure of the five points is understandable if we look at points one and two together, both have bearing on the position of a building on its site. One of the postulations in point one, the column, is that they raise the house off the ground, lifting the rooms away from the damp ground surface and allowing light and air to circulate freely. The garden passes under the house, and the same amount of outside space is created on the roof. Point two, the roof-garden, goes on to state that "in general the roof-garden means that a city can regain its entire built area". These first two points together thus suggest that modern buildings are siteless

objects in a continuous (urban) landscape. The mass-produced automobile stood model for the siteless, mass-produced house, which had a profound impact on urbanism.

The five points themselves also contain reference to the design theme of the period – the theme of abstract form found in Cubism. Notably the last two points, the ribbon window and the free façade, point clearly in this direction

The ribbon window extends from one structural column all the way over to the next one, allowing for uniform day lighting inside the building. Unlike the traditional window, which in simple terms is a hole punched into a structural wall, whereas the ribbon window gives no clue to either the various functions or the floor levels behind the façade.

On the other hand, the facade, by which is meant the exterior wall, are no longer load-bearing and could as a result be opened up or closed at will to satisfy functional and aesthetic requirements.

Fig. 7.10. A sketch by Le Corbusier demonstrating the Four Compositions

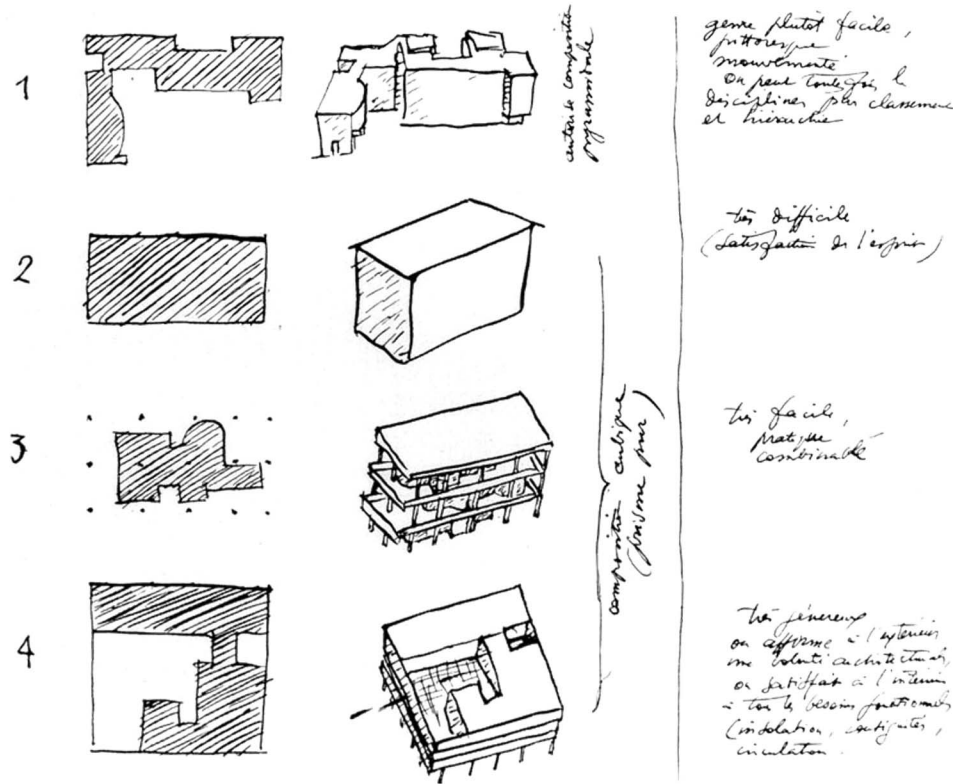

## The Four Compositions

Eventually, Le Corbusier categorised the spatial organisations derived from the points as the 'four compositions'. His important sketch of the differing modes of composition (fig. 7.10) permits an examination of the method he employed both for the functional programme and for the total organisation of the design.

'Four Designs, for four different villas', show the construction of the mass schematically and chronologically (fig. 10): The first is a composite "picturesque" form (Maison La Roche-Jeannerette, 1923/24), where each element grows organically beside its neighbour. The impulse emanates from the interior and pushes against the exterior, producing various projections. The second type is a simple box (Villa Meyer, 1925/26 and Villa Stein de Monzie, 1926/27), which contains the organic parts with its rigid, clean-cut envelope. The third type is a basic form defined by free floor slabs, with freely placed interior walls (Villa Baizeau II, 1929) and finally, the Villa Savoy (1928/29), is shown as the most sophisticated scheme, it has the simple external form of the second-type, but its interior has the advantages and qualities of the first and second type. The basic organisation of the villa is formed by regularly disposed pilotis which support a white box with a projection on two sides. Within this basic form the outside walls and curved lines of the roof garden are freely disposed.

This deliberate recognition of a relationship

between a free programmatic development on the one hand, and the requirements of the external form on the other, represents an important contribution to architecture.

## Promenade Architecturale: Dynamic Space

With didactic intent Le Corbusier also teaches us to gain access to the interpretive experience of architectural space. He declares this interest in the experiential qualities of architecture through the concept of the promenade architecturale and he writes of that interest by what appears to be a straightforward description of experience. Straightforward in the sense that the description, of the experience of architecture, is denominated by a particular point of view, that of the body moving through space.

Regarding the promenade of his seminal work the Villa Savoye, Le Corbusier notes: *“Arab architecture teaches us a precious lesson. It is best appreciated by walking, on foot. It is when walking, when moving, that one sees the ordering principles of architecture unfold”* (Risselada 1988:23)

Elsewhere he writes... *“The plan of a building is a human appropriation of space. We walk about the plan; our eyes forward, for perception is sequential; it takes place in time; it is a series of visual events, just as a symphony is a series of auditory events”* (Guiton 1981: 54)

In modern architecture the notion of dynamic space found a clear expression in Le Corbusier's work. His projects for houses in the twenties need to be understood from the point of view of the moving body. The movement through the building is channelled through architectural

elements, like the ramps in villa Roche and Villa Savoye (fig. 7.11), and culminates on the roof garden. Other elements, like the spiral stair, express in their forms the idea of dynamism and movement (fig. 7.12).

If in painting, form and space make an inseparable unity, the same could be said about the architectural promenade found in modern architecture. The forms give expression to the new spatial concept: a space that flows continuously throughout the building, from the inside to the outside. Spaces are more a-proiori, abstract space, populated by objects. The columns, stairs, and walls are abstract objects that punctuate the space and they become references that help the visitor to reproduce in the mind the spatial configuration of the building.

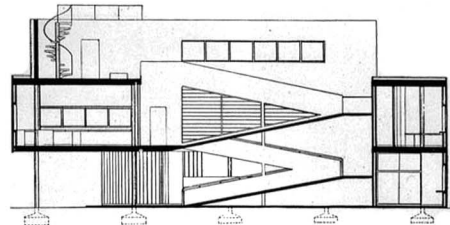

Fig. 7.11. A section through Villa Savoye revealing the ramp as the architectural element along which movement is channelled



Fig. 7.12. The spiral staircase, expressing dynamism in its form





Fig. 7.13. Carpenter Center for the Visual Arts, Harvard University 1963



Fig. 7.14. Millowners' Association Building 1954

# modern design *analysis*

## MODERN PRINCIPLES FOUND IN BERRALS BUILDING

The study of the Berrals building reveals several of the fundamental components of modern architecture. Unfortunately when examining the structure from a critical point of view, the principles are not completely implemented, even though their potentials are inherent to the structure. Of the Five Points of a New Architecture, four are present, and it seems as though some hint at being a mere aesthetic treatment.

The four points visible in the Berrals are the column structure (1), the free plan (3), the ribbon window (4) and the free façade (5):

### Point One: The Column

The column structure of the Berrals consists of rectangular reinforced concrete posts on all levels as well as an extra set of round pilots on the ground level carrying the reinforced concrete cantilever canopy.

### Point Three: The Free Plan

The free plan is visible but unfortunately only on the ground floor, with the upper levels having a definite enclosed interior wall system disregarding the column structure.

Fig. 7.15. Original Ground Floor Plan indicating position of Columns

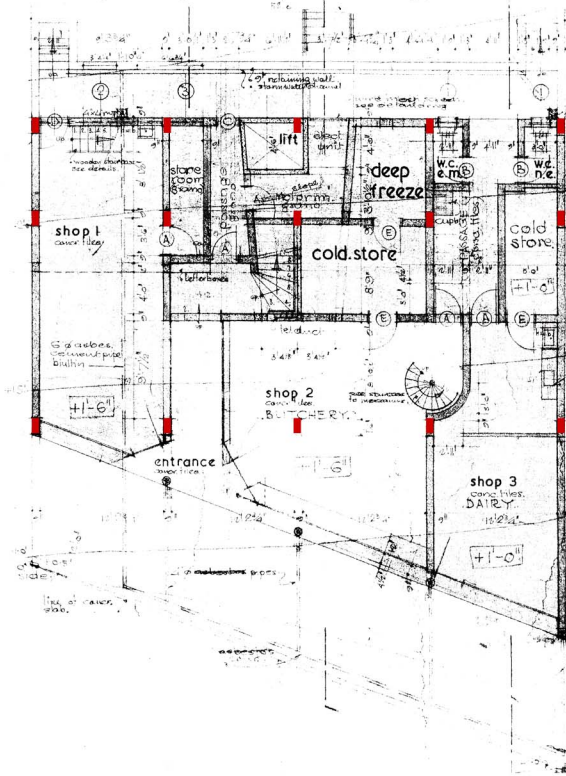

Fig. 7.16. Original Mezzanine Floor Plan indicating position of Columns

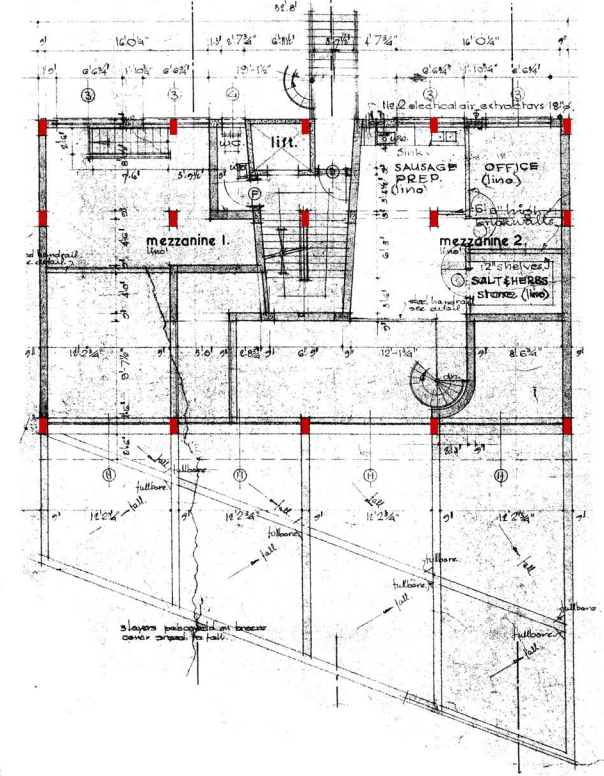

Fig. 7.17. First, Second, Third and Fourth Floor Plans indicating position of Coumns

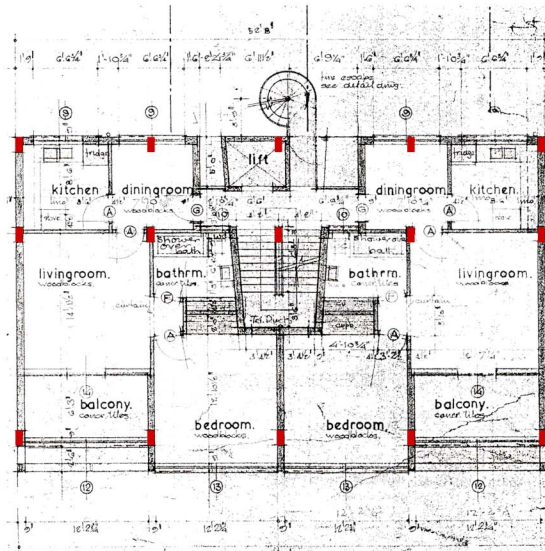
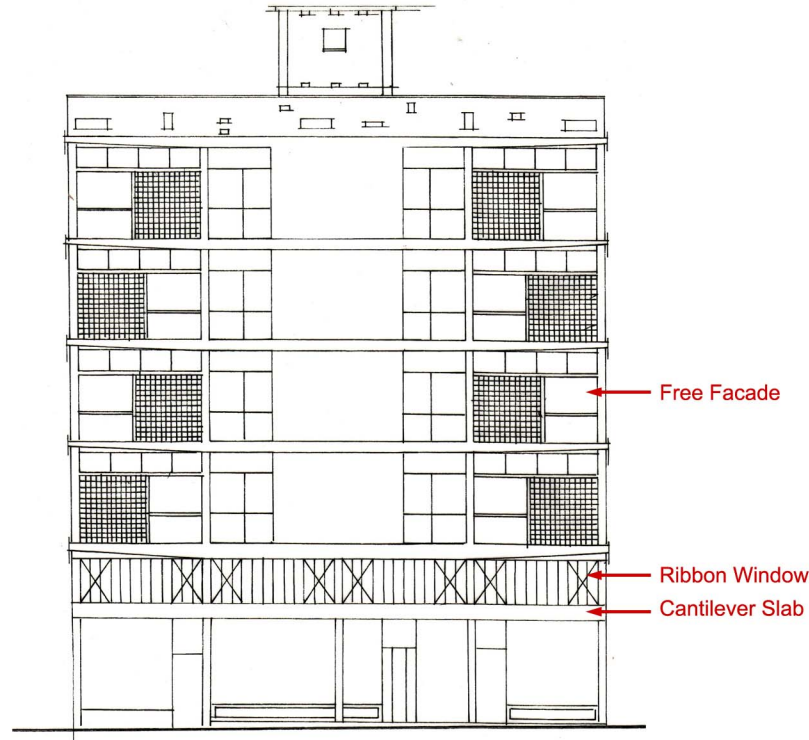

Fig. 7.18. Ribbon Window and Free Façade with 'Brise Soleil' Screens



## Point Four: The Ribbon Window

On the front façade a ribbon window running the building's length forms the division between the free façade and the cantilever slab. The back façade, that was not meant to be visible, but due to the change in the urban fabric since its construction is highly visible today. It reveals rows of fenestration on each level and though these rows of windows are not as successful at conveying the idea of the ribbon window as the front façade window, there is a definite association with the idea.

## Point Five: The Free Façade

The free façade is most likely the most significant modern component found in the Berrals building, executed exquisitely. It carries the building's modern integrity in being one of the Five Points as well as showing regional intent by incorporating the 'brise soleil' or screen as part of its construction. It consists of hollow clay bricks in concrete frames, alluding to the Brazilian influence on Pretoria Regionalism, and is carried out in alternating pattern, symmetrical to the stair and lift shaft at the back of the building. Even though it is a great example of a 'brise soleil' it is sadly only applied for effect as it has no real climatic influence, but as it has turned out, this has been the case with several modern buildings.

Fig. 7.19. The Ribbon Window and Free Facade 'with 'Brise Soleil' Screens



Fig. 7.20. The view from Skinner Street revealing the rows of windows on the back facade



Fig. 7.21. A sketch of the back facade

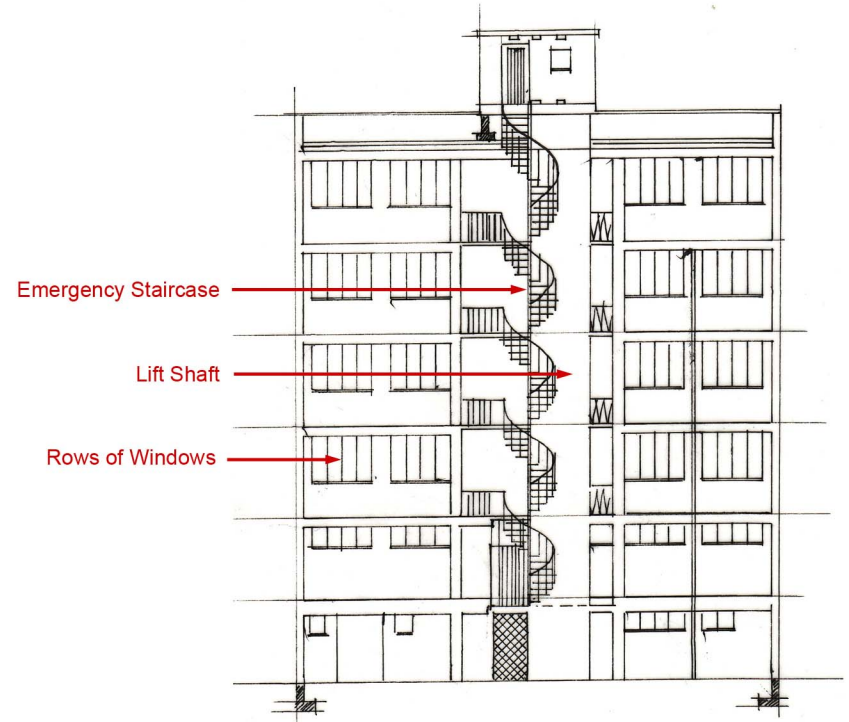
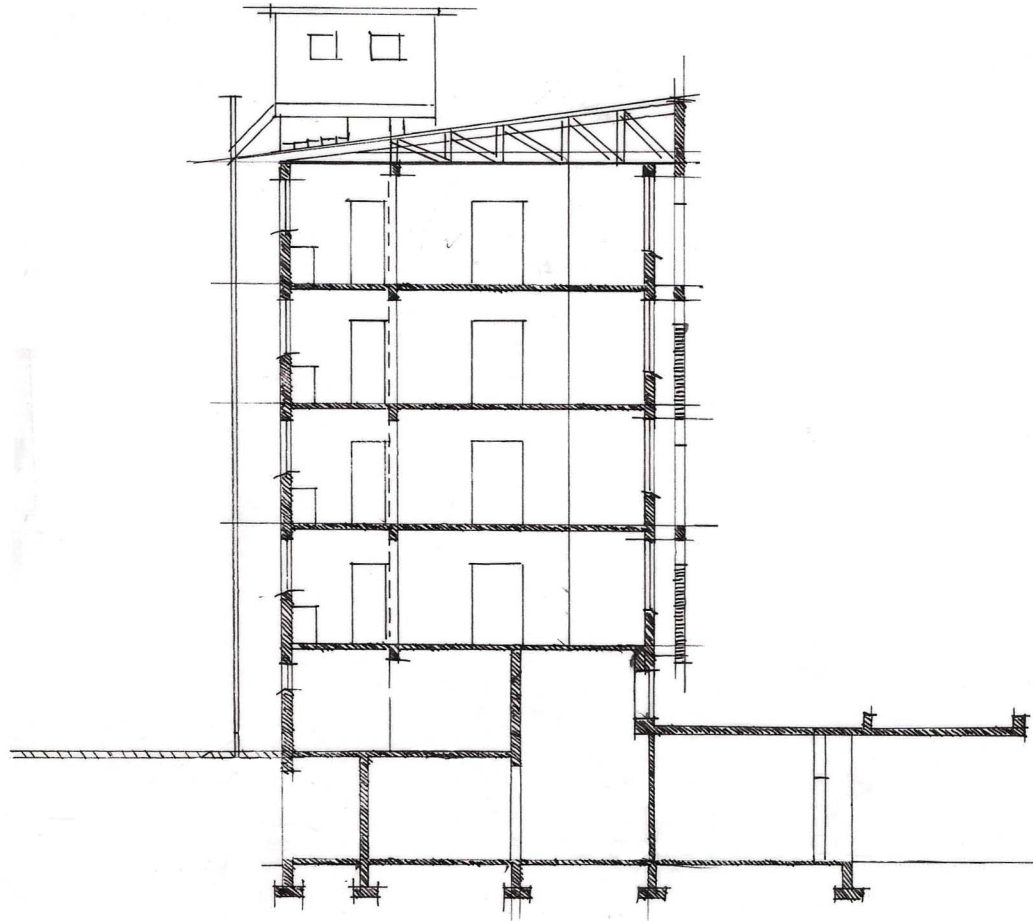

Fig. 7.22.. Sectional sketch showing Roof Structure of Berrals



One of the five points was left out in the design of the Berrals building, it is the second point in the original structure of the five points , the roof garden:

### Point Two: Roof Garden

The Roof-Garden was completely discarded, most likely due to the regional mutation of the style in order to consider climatic conditions as well as account for locally available material and cost. The production of corrugated iron in Pretoria is probably the most likely reason, as it was replaced with a Howe truss and corrugated roof.

### Spatial Concept: Promenade Architecturale

In terms of spatial organisation, the position of the stair in a central position within the space places a certain amount of emphasis on the vertical connection of floors. The rest of the internal spatial layout propagates from this point and it resembles the architectural promenade as spatial experience, focussing on the body moving through the building. The position of the stair in relation to the open lift and the lift lobby pulls the landscape into the spatial experience as views are sequentially revealed, sadly a culminating point for this spatial experience is lacking, which was usually found on the roof-garden, as well as the fact that the views are revealed at the back of the building, implicating that the stairs are being hidden not to interfere

with the free façade at the front. It must be mentioned though, that from the back the CBD is in view.

Other observations made that relates to modern ideals are the change in the urban fabric, which positions the building on an island, and that is in reality more favourable than its original position with competing surrounding structures. The building can be interpreted as the idealised 'siteless object'. It stands alone with little or no relation to its surroundings, like a reproducible unit. This position also establishes the building as a landmark icon.

Fig. 7.23. Plan indicating central position of the main stair

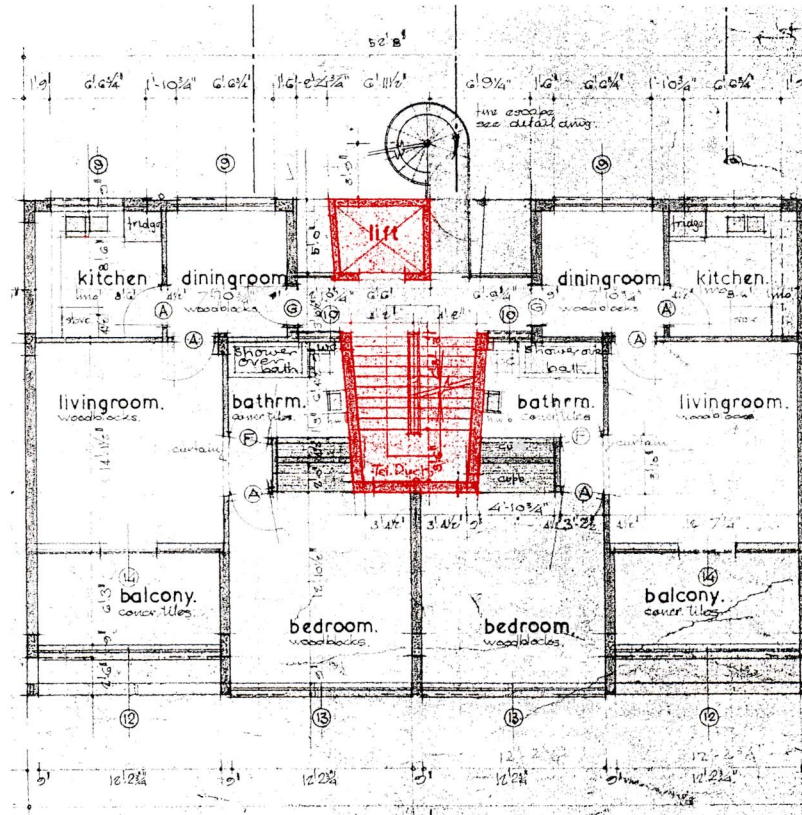

# functional *programme*

## A RECOMBINANT PUBLIC FACILITY

Fig. 7.24. An example of a space that is similar than the proposed Mediathèque



The program is based on a new type of public resource facility combining an Information Centre with a Médiathèque.

### Information Centre

The Information Centre is situated on the ground floor and mezzanine level with split-level entrances, while the Médiathèque is located on the upper 4 floors.

The ground floor provides the main entrance to the facility leading into a Café, which functions as an informal waiting and meeting space for the Information Centre. The Café will operate as part of the Information Centre but will function as a destination in its own right. The mezzanine level accommodates the Information desk, providing general information as well as a concierge service, to assist visitors with booking arrangements of accommodation, transport, tours and entertainment. Flanking the Information Desk is a waiting area with an alternative entrance leading out onto the transport and tour pick-up zone. A quick internet interface is available to users for self booking and browsing.

### Mediathèque

The Médiathèque is spread over four levels. The First floor functions as the foyer to the Médiathèque, providing a reception for the checking in of media material as well as the booking of facilities. The second and third floor functions as a flexible library space offering, shelves of media, study space, as well as possible exhibition space. The fourth floor, consists of a loggia and roof-garden utilised as a private reading lounge or events space, with great view of the city in all directions.

# design *development*

## A RE-INTERPRETATION OF MODERN DESIGN PRINCIPLES

### Site Rationale: Summary in terms of design influence

The choice of the Berrals building as site was determined by its position at the intersection of several functional areas. It presented an opportunity to stitch the urban fabric together, which was fragmented by the construction of the Nelson Mandela Roadway. The building has been isolated on an island, between the CBD, the high rise residential area of Berea, and the mixed-use area of Sunnyside. It also borders the Apies River green corridor and aligns perfectly with the axis of Esselen Street, a highly pedestrianised street along which the Department of Trade and Industry (DTI) is located. This intersection in the urban fabric has several well established pedestrian routes linking the different functional areas.

The Berrals is a landmark at this chaotic junction of roadways and activities. It is highly visible from all approaches and the fact that the sides of the Berrals are employed as billboard spaces only underlines this reality. The reverse is true as well, as the Berrals offers 360 degree views of the city. To the east the Berrals overlook Sunnyside, in particular Esselen Street as well as the Apies river green space and in the distance the Union buildings. To the west, the Inner City is visible

with views of the ABSA Building, the Reserve Bank and Town Hall. To the south, the University of South Africa is visible.

### Circulation

In the book, *Radiant City*, Le Corbusier notes (1964:289) an organisational ideal found in modern planning: *"The ground floor is devoted to movement: pedestrians, cars. Everything above the ground (the building) is devoted to stability. No similarity between the two. The ground beneath the building must be freed, for regular streams of cars and lakes of pedestrians. The streams flow directly to certain entrances. This makes for a new economy of layout."*

The analysis of the Berrals reveals a similar functional division where the column structure elevates the main space above the ground floor, within a defined static box, unlike the upper levels, the ground floor promotes an open spatial experience. A split-level is present in the space under the elevated box, introducing a mezzanine level. This enables two entrances, one leading into the building from the eastern side on ground floor and another from the western side, from Kotze street, on to the mezzanine level.

Fig. 7.25. A conceptual sketch demonstrating the linear circulation possible when two of the surrounding roads are use as part of a pick-up and drop-off system

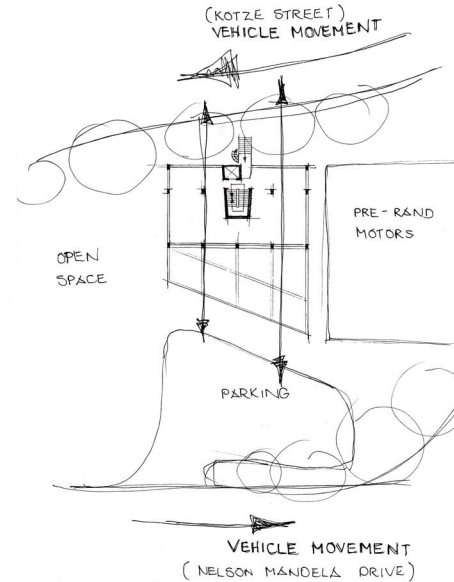
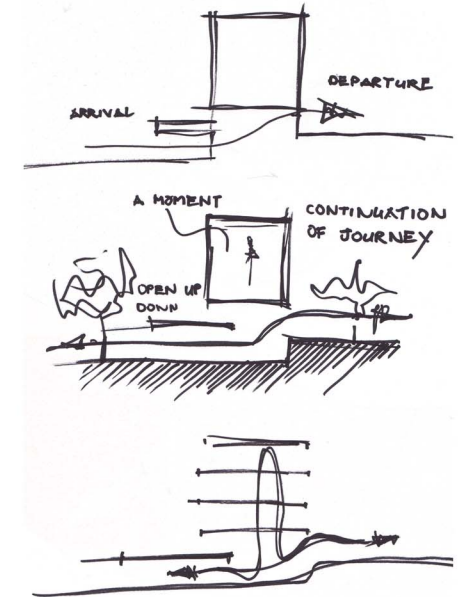

Fig. 7.26. A diagrams indicatic the static elevated box hovering over the circulation space





With a functional programme that requires circulation spaces for the quick interfacing of the Information Centre and static spaces where users of the Mediatheque can linger undisturbed, the Berrals became the ideal spatial container for the dual functional nature of the facility.

The Information Centre's functional programme needed to consider a pick-up and drop-off system for tour and transport activities, emanating from the centre. With the ring road system surrounding the Berrals a linear circulation system became evident, pulling the user in from one side as a drop-off point and providing a pick-up point at the other side. This presented a space that would be easily legible and practical for the user moving through the space as well strengthening modern ideals of dedicating the ground floor to circulation.

As the design progressed, the circulation system developed much more into a multi-directional system, offering two main entrances into the facility from different approaches. The front entrance functions as an informal drop-off point for users, while the back entrance is linked to a formal drop-off and pick up zone for tours and transport.

## Stripping to the essentials

The next step in the conceptual process was the stripping of the building to its essential modern components, the column and the free plan. An act in itself possessing Purist qualities, eliminating all that seems unnecessary.

The process of freeing the interior space to reveal its column structure was not only determined by the fact that the free plan is the theoretical focal point of modern architecture, but its a response to the limited floor space of the Berrals, which was aggravated by the enclosed interior wall systems as well as the central position of the stair in the interior space.

To keep the plan free, the addition of basic amenities, such as the lift, staircases, and toilet facilities, crucial to the functioning of the building, was moved to the outside. As most of these amenities are repeated on each level and form vertical cores through the whole length of the building. The decision was made to free the plan of all vertical cores by moving them outside of the existing interior space and attaching them to the exterior.

Fig. 7.27. The split-level circulation under the main space

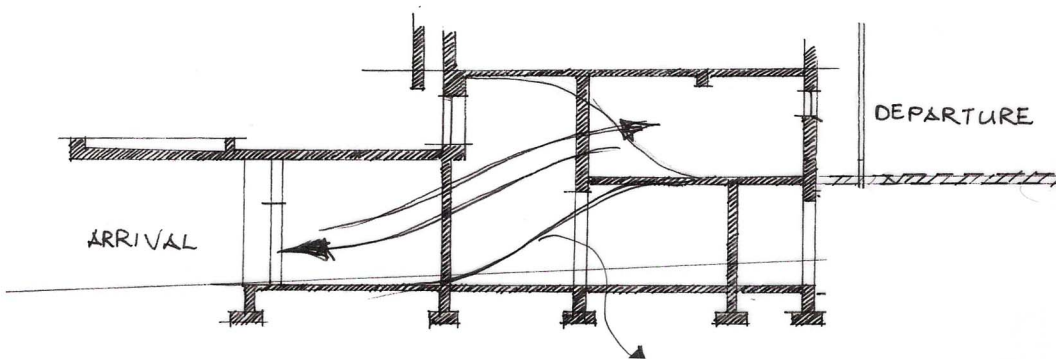

## Early Conceptualisation

Early in the design process it became clear that the central position of the original stair within the Berrals building was a crucial design decision. It placed the focus of the spatial experience on the practice of moving through the building and this concept was closely related to the spatial experience described by Le Corbusier as one from the point of view of a moving body.

Functionally, the proposed centre, provides an en route stop on the journey through the city, and conceptually the idea developed that the centre should become a spatial extension of the journey through the city, by means of the promenade architecturale.

It becomes a vertical moment in the horizontal movement in the city and the continuation of the users journey within the space became the main spatial conception.



## Section through Berrals to reveal

The stripping of the interior space to the basic constructional premise of the free plan, in other words, the column grid, reveals its relation to the strong proportional system found in the front free facade. The column grid, aligning with the front facade, consists of a system of columns with 4 equal structural bays. The rhythm of the columns and structural bays are evident in the proportions of the facade. The two central structural bays are part of the solid vertical part of the facade where as the two outer bays, one to each side, is set back to provide space for the 'floating' 'brise soleil'.

Following the column grid as space informer, the main vertical ascent, as the main spatial experience, was carefully inserted, between the column grid through the front facade of the Berrals, to reveal the city as part of the spatial journey.

The insertion through the front facade is no coincidence, as this position announces the importance of the vertical movement in the spatial organisation of the project, and as the front facade is the strongest and most visible of the historic modern elements it pulls attention, to where the intervention, thus the edge between the old and the new.

The strong proportional and set composition of the front facade, reveals a crisp line between the new materials and the existing.

