



vehicle \_ FOR AN AERIAL TRANSPORT SYSTEM



UNIVERSITEIT VAN PRETORIA  
UNIVERSITY OF PRETORIA  
YUNIBESITHI YA PRETORIA



UNIVERSITEIT VAN PRETORIA  
UNIVERSITY OF PRETORIA  
YUNIBESITHI YA PRETORIA



ELITA LOUW  
NOVEMBER 2008  
MENTOR > NICO BOTES  
STUDY LEADER > NICO BOTES

UNIVERSITY OF PRETORIA DEPARTMENT OF ARCHITECTURE  
SUBMITTED AS PART OF THE REQUIREMENTS FOR THE DEGREE MAGISTER IN INTERIOR ARCHITECTURE [PROFESSIONAL]  
IN THE FACULTY OF ENGINEERING, THE BUILT ENVIRONMENT AND INFORMATION TECHNOLOGY



Figure 1: aerial transport (Louw: 2008)





## Vehicle \_ FOR AN AERIAL TRANSPORT SYSTEM

This thesis deals with the interior architecture of aerial transport systems as a method of transport.

The hypothesis argues that social barriers can be challenged through the physical formation of the aerial systems, its structure, assembly and adaptability to seasonal site.

The platform used to explore this premise is the Sani Pass in the Southern Drakensberg. There is a stigmatization around cable car systems within the raw, primal, vast and overwhelming South African landscape. It is a silent debate lingering within every mind at the mere mentioning of an aerial cable car system.

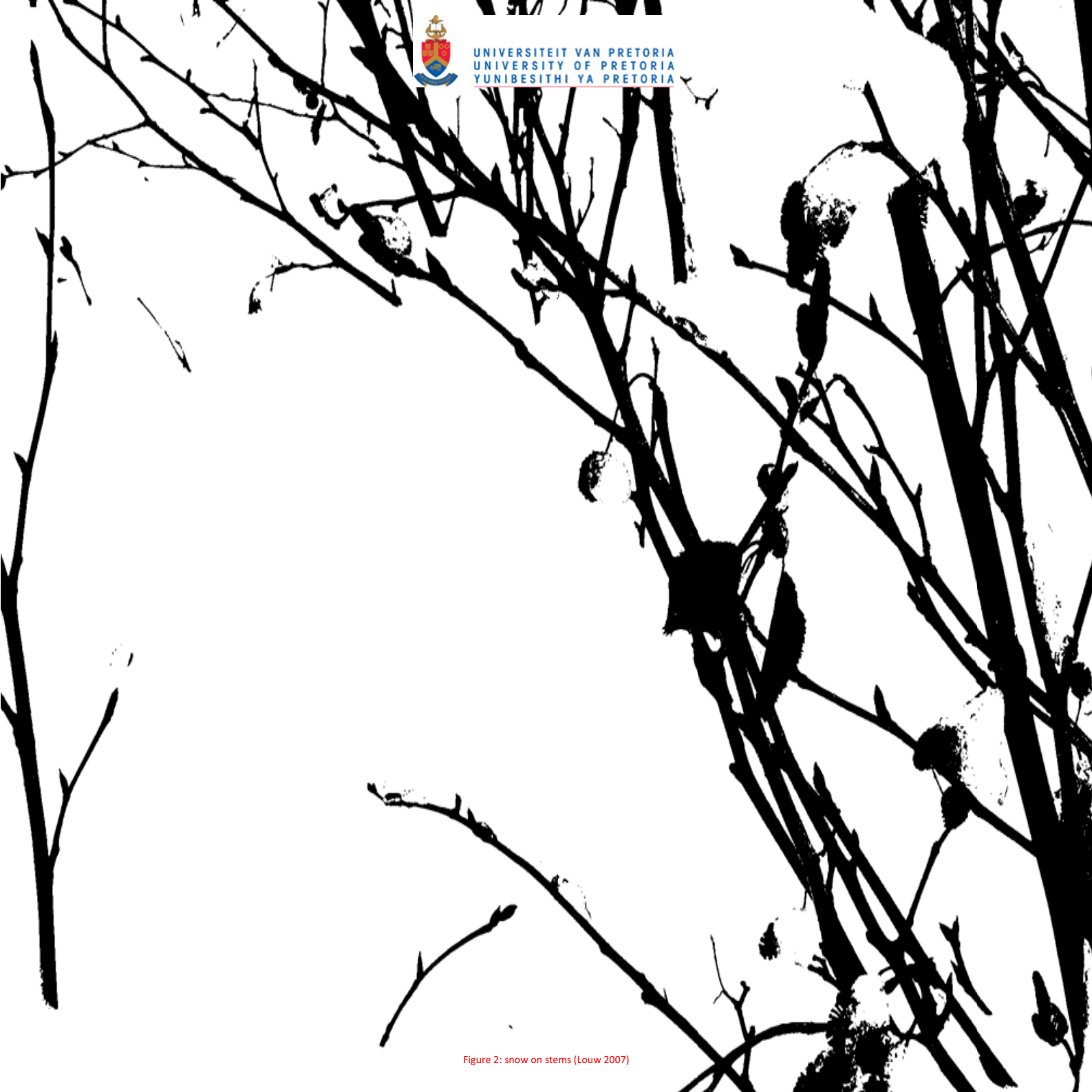

Figure 2: snow on stems (Louw 2007)

**CONTENT**

<b>CONTENT</b> .....	vii
<b>LIST OF FIGURES</b> .....	ix
<b>LIST OF TABLES</b> .....	ix
<b>A THOUGHT</b> .....	2
<b>INTRODUCTION</b> .....	4
<b>DESIGN TASK</b> .....	6
PROBLEM STATEMENT .....	6
THE CHALLENGE .....	8
DESIGN OBJECTIVE .....	8
<b>CONTEXT STUDY</b> .....	10
SITE.....	10
USER PROFILE .....	12
<b>PRECEDENTS</b> .....	14
Galzigbahn.....	14
Marion Island .....	16
Antarctic Halley VI.....	18
Contemporary Art Container .....	20
Zaragoza Bridge Pavilion.....	20
Honda Puyo.....	22
<b>BASELINE STUDY</b> .....	24
1. GENERAL DESIGN .....	24
2. CARRIAGE CONSIDERATIONS .....	26
3. STATIONS.....	28
4. CONSTRUCTION CONDITIONS.....	30
5. COMMUNICATIONS .....	30
<b>CONCEPTUAL THINKING</b> .....	32
TERMINAL .....	32
CARRIAGE .....	36
<b>DESIGN DISCOURSE</b> .....	42
PRODUCT DESIGN .....	42
NEW DESIGN: AN ERA OF HYBRID PRODUCTS .....	42
ERGONOMICS .....	42
MULTI FUNCTIONALITY .....	44
LIFE CYCLE AND SUSTAINABILITY .....	44
COLOUR.....	46
TEXTURE .....	46
PROPORTION .....	46
INCLUSIVE DESIGN .....	50
<b>TECHNICAL RESOLUTION</b> .....	60
MATERIALS .....	62
PMMA (polymethylmethacrylate) .....	64
ASSEMBLY AND FASTENING .....	72
<b>DESIGN DRAWINGS</b> .....	74
<b>BIBLIOGRAPHY</b> .....	75
<b>APPENDICES 1: TERMINOLOGY AND DEFINITIONS</b> .....	80
<b>APPENDICES2: MANUFACTURING</b> .....	86



Figure 3: "gondola" cable car (Louw 2007)



## LIST OF FIGURES

Figure 1: aerial transport (Louw: 2008).....	iv
Figure 2: snow on stems (Louw 2007).....	vi
Figure 3: "gondola" cable car (Louw 2007).....	viii
Figure 4: winter sport (www.flickr.com).....	1
Figure 5: extreme skiing (www.flickr.com).....	3
Figure 6: snowboarding (www.flickr.com).....	5
Figure 7 aerial transport (Louw: 2008).....	5
Figure 8: topographic map of Lesotho and rest of the contextual site ( <a href="http://maloti.co.za">http://maloti.co.za</a> ).....	9
Figure 9: pictures multiple users designed for (www.flickr.com).....	11
Figure 10: the Galzighbahn base terminal ( <a href="http://www.ropeways.net/aktuell/galzigbahn/galzigbahn.htm">www.ropeways.net/aktuell/galzigbahn/galzigbahn.htm</a> ).....	13
Figure 11: new base scientific base at Marion Island (Raath: 2008).....	15
Figure 12: a module of the new Antarctic Halley VI base (Raath: 2008).....	17
Figure 13: interior of the bridge pavilion ( <a href="http://www.ihalife.com/blogs/entries/7008.htm">www.ihalife.com/blogs/entries/7008.htm</a> ).....	19
Figure 14: new Honda concept car ( <a href="http://www.hydrogencarsnow.com/Honda-Puyo.htm">www.hydrogencarsnow.com/Honda-Puyo.htm</a> ).....	21
Figure 15: safety principles should be followed due to high risk transport system (Louw: 2005).....	23
Figure 16: strong alloy structure, enhancing safety (Louw: 2004).....	25
Figure 17: a typical terminal with proper signage and safety (Louw: 2007).....	27
Figure 18: terminal construction complying with proper safety mechanisms (Louw: 2005).....	29
Figure 19: proposed terminal layout and data.....	31
Figure 20: terminal design considerations and system analysis planning.....	33
Figure 21: carriage design considerations and system analysis planning.....	35
Figure 22: carriage design, ergonomic application and planning.....	37
Figure 23: vehicles moving through the "ferris wheel".....	39
Figure 24: design should consider size, age and culture (Louw: 2007).....	41
Figure 25: designing with nature - sustainable (Louw: 2008).....	43
Figure 26: colour, texture and proportion on the Lesotho Mountains (Louw: 2008).....	45
Figure 27: proposed Lesotho brand.....	47
Figure 28: contrast ( <a href="http://www.core77.com">www.core77.com</a> ).....	49
Figure 29: clear and visible lettering in a gondola (Louw: 2007).....	51
Figure 30: a Pictographs/pictograms communicating spaces ( <a href="http://www.architonic.com">www.architonic.com</a> ).....	53
Figure 31: application of visible controls and distinctive objects ( <a href="http://www.jeep.co.za">www.jeep.co.za</a> ).....	55
Figure 32: gondola in Bulgaria (Louw: 2005).....	57
Figure 33: mountain activities and detachable chairlifts (Louw: 2005).....	59
Figure 24: exploring people, materials and texture (Louw: 2007).....	61
Figure 35: contemporary PMMA three dimensional systems ( <a href="http://www.designsponge.blogspot.com">http://www.designsponge.blogspot.com</a> ).....	63
Figure 36: German Tiger Helicopter Equipped PMMA protective glazing (Moore: 2007).....	65
Figure 37: Marion Island base roof panel prepared for resin infusion (Moore: 2007).....	67
Figure 38: manufactured GRP component by MMS Technologies (Moore: 2007).....	69
Figure 39: component assembly of the body (lobes) of the designed vehicle.....	71
Figure 40: mountains and an aerial transport system (Louw:2005).....	73
Figure 41: mountains and an aerial transport system (Louw:2005).....	79
Figure 42: Resin Transfer Moulding (Composite Materials information sheet 2007).....	87
Figure 43 Wet-Lay-Up/Hand Lay-Up (Composite Materials information sheet 2007).....	88
Figure 44: Vacuum Bagging (Composite Materials information sheet 2007).....	89
Figure 45: Resin Film Infusion (Composite Materials information sheet 2007).....	90
Figure 43: the three unit types.....	90

## LIST OF TABLES

Table 1: Terminal design and distances travelled.....	32
Table 2: material strength of GRP compared steel and cement (Composite Materials information sheet 2007).....	68



Figure 4: winter sport ([www.flickr.com](http://www.flickr.com))

## A THOUGHT

Bookchin (1980:22) states that social ecology integrates "the human and natural ecosystems through understanding the interrelationships of culture and nature." He also claims that social ecology shares ideas with holism. Social ecology argues that people are interdependent, and should live in harmony with nature.

Social ecology "not only provides a critique of the split between humanity and nature; it also poses the need to heal them," says Professor Bookchin.

Social ecology is a plan for a new type of human community, with a new relationship with the non-human world.

Bookchin claims that social ecology has its origins in humanity's initial awareness of its own sociality. By this Bookchin means that social ecology has its inspiration in the relationship which ancient communities had with the natural world; a relationship in which nature was an active partner in human society rather than being "mummified and muted" as in modern society. In the ecological community of the future, relations between people and non-human nature will more closely resemble relations in what Bookchin calls "organic communities" – communities from the distant past which were characterized by a sexual division of labour and by the absence of hierarchy.

One of the fundamental principles of modern biology is that processes occurring in organisms obey the laws of chemistry and physics, just as processes in non-living systems do. The special properties of life arise because of the complex organization of organisms and the chemical processes that occur within them (biocentric based on biology). The anthropocentric system functions in the same way. The human specie still remains a biological form of life and reacts similar to other forms of life. However, design also resembles biology but is influenced and determined by social ecology. White males previously dominated the *nuclei* but with social evolution, females and other races have become part of this essential density. A sub-cultural boundary has been crossed. The structure of the eccentric cell remains the same with the centre on the one side of the community, forming a boundary of the community and bulging into the community, although the various nuclei and density rings remain.

As Bookchin's social ecology is mutating, ethnic, cultural and gender conflicts are waning. Females, blacks, children, everybody are merging within these social cells. *Promenades* are becoming part of the *interchange* and all is changing green. The entire infrastructure is more aware of the environment and this boundary between eccentric nuclei is amalgamating biocentric and the anthropocentric. People (all cultures) are merged with nature and walking green routes to work, it's evolution of a social ecology.

Relaying away from destructive ideas of people - architects - hindering the nervous tissue of ecosystems and communities within, and rather recognizing shortcomings within the structure of reconstructing (and redesigning) one could intentionally realize needs within the primal landscape and design upon these needs without hindering. We are romanticizing and redesigning poverty, and somehow we see this as a primal goal – to keep a culture untouched. We are protecting, restoring and procuring a community (instead of the surrounding structures) that longs for contemporary architectural development. We are inherently trying to keep the infant infantile, forgetting that all forms of life will grow. Allison Jagger (1983:56) defines oppression as: " hierarchy, a specific form of domination in which those on the upper side unjustly deprive those on the lower side autonomy and self-determination by unfairly restricting."

In conclusion, the thesis that follows will challenge the above by accepting nature as an entity and designing in response, but also realizing that the community within range should be seen as another creative, living and growing entity with assimilating needs and alliterating ideas.



© University of Pretoria

Figure 5: extreme skiing ([www.flickr.com](http://www.flickr.com))



## INTRODUCTION



If architecture is concerned with the large scale matter of spaces (creating boundaries), the specialisation of interior architecture considers the human scale and experiences inherent in the public and private matter of a space (exploration within boundaries); it is an expression of our encounter with spatial cultivation. As interior architects, we are concerned with authentic architectural experience, and the development of a multi-sensory approach to space which facilitates a sense of belonging and integration. We create comfortable spaces from the point of view of the user.

It is also a spatial art that differs from both architecture and interior design in its full commitment to rethinking the life of existing structures - through design alterations, rehabilitation and adaptive reuse.

The idea of experimenting with new spatial concepts, intensifying existing structures and exploring new materials in the pursuit of a visionary aesthetic that encompasses all fields of design has led to the notion of designing a new vehicle (alias “cable car”) as part of an aerial transport system. The vehicle will require extreme levels of complexity and intense research into diminutive spaces (applying ergonomics to every extent), materials and engineered structures.

This document will start with a recognised problem statement within the context of Lesotho and then gives a design proposal in the form of an alternative transport method, being the cable car. The site will then be briefly discussed to create an apparent context in which the ‘cable car’ will be designed. The document will then transcend into a clear design objective followed by various precedents which will strengthen design resolutions. A concise conceptual section which will communicate aspects of the system as a whole and the carriage as an entity, these inceptions will be followed by the design discourse where all aspects from colour, texture to branding are analysed and incorporated. By then the reader should have a clear understanding of the design objectives and the technical resolution will be presented. The document will then follow with a final conclusion.

>>>



Figure 6: snowboarding ([www.flickr.com](http://www.flickr.com))

## DESIGN TASK

### PROBLEM STATEMENT

In most countries, governments have attended to the needs of people to travel quickly from one place to another by introducing public transport systems such as busses, taxis, trams, light-rail systems, aerial transport systems and rapid underground trains. These systems have, however, remained in a mutualism on urban scale and the rural landscapes have gained little. Even though all reason magnetically rejects any form of advanced designed systems within the rural rawness, the Europeans have somehow managed to place these systems within pristine context so that the landscape remains mythical. Aerial tramways graze along the highest and pristine European mountains, rationalising structures that live and breathe with their surroundings, respecting it. Some of these structures (gondola) have, however, aged and a new generation of aerial lifts and vehicles has only now been designed and implemented (funitel).

The exterior shell of the common “cable car” is meticulously designed with a definite symmetric squareness which aids in balance. However this much used shape hasn’t changed since day one on the ‘cable car’ timeline. New engineered hangers and ropeway systems have been designed to strengthen the system, but the four-sided figure remained. The interior of the carriages are clustered and little thought has gone into user interfaces, inclusive design or commuter experience.

The interior space of the vehicle communicates starkness and has claustrophobic spaces where little is done to create the illusion of spaciousness. Standard seating and sliding doors are the only two components occurring within this trivial space and the vehicle has the sole function of plural transportation. There is thus space to explore new designs within the gist of the traditional and functional ‘cable car’.

Through the act of translucency and colour one can start to make the passenger aware of his/her context and stimulate interaction between passenger and context. By stretching and bending structure and space one can create storage spaces, design adaptable seating units, and augment views. One can convert a seasonal entity into a multi-seasonal entity. One can enhance an overall entity by simply putting thought into design and researching the brand new.



Figure 7: "funitel" cable car (<http://www.ppcwa.net/>)



## THE CHALLENGE

The sinuous shell of the vehicle, compared to horizontal and vertical surfaces, posed a significant challenge. This meant the development of a whole new set of criteria and strategies. Another challenge was the context of the vehicle, the sky and the concept of constant movement. Compared to land-based interior architecture one has to contend with notions such as comfort, weight, balance and humidity.

The dissertation will be .... Commitment to the exploration of the essence of form and space. Designing a fully functional structure complete with seating, storage compartments and tangible user interfaces. The cable car will also be a symbol of the notion of movement and commuting. Its disquieting form will levitate in response to the human body but will still remain functional as to enhance interchange and commuting. The vehicle will be designed to the greatest level of detail. Vehicle assembly and branding will also form part of the vehicle design and resolution. Accompanying supporting structures such as transition, recreational, and toilet facilities promoting accessibility, clarity and comfort will be dealt with up until conceptual phase but will not include detail design.

## DESIGN OBJECTIVE

A commendable identity should be portrayed through a sustainable design with functional anthropometric systems and inviting spaces. Safety, functionality, and aesthetic quality are generally required from the design and with considerations of typology of the infill structure and product should metamorph through conceptual phases into a full-grown design. Ergonomics and scale should be taken into spatial consideration.

These features are a principle design goal that should be reached to generate effective spaces in and around the aerial tramway. The vehicle as an entity may enrich the commuters' (tourists) experience and as a result could generate more commuters, which will attract and bring about a higher frequency of tourism and subsequently generate work opportunities on various levels within the rural area. Within the rural and democratic context of both South Africa and Lesotho, it is vital that this aerial transport system functions as a social equitable line in which people of all races and cultures can interact and commute, whether they are poets or mountaineers.

Another design challenge lies within material selection of both the membrane and components of the vehicle. Materials have three overlapping roles: that of providing technical functionality, that of sustainability and that of product personality. The designer should communicate all three of these foreign aspects into one spoken language. The design should thus communicate an appealing green durability.

The integration of spaces of intermission and "dwelling" within a structure that primarily conveys movement and flow will be exploited on a primary level, with the sole purpose of understanding the system as a whole, and how the vehicle design will enhance commuting not only as a function but as an experience as well. How does one allow for lingering without interfering or delaying a two-way circulation and on the same level of debate not hinder the dweller? These complex analytical movement patterns should both be accommodated for in exhibiting an effective spatial system.

Interior architecture has broken out of the box, literally and figuratively. New technologies in materials, design and construction have at last begun to transform the built environment. Boundaries that have separated architecture from art and design have fallen. Space and the very idea of it and how it can be manipulated functionally, have evolved greatly by the artist's understanding and expression of a third dimension and molecular awareness.

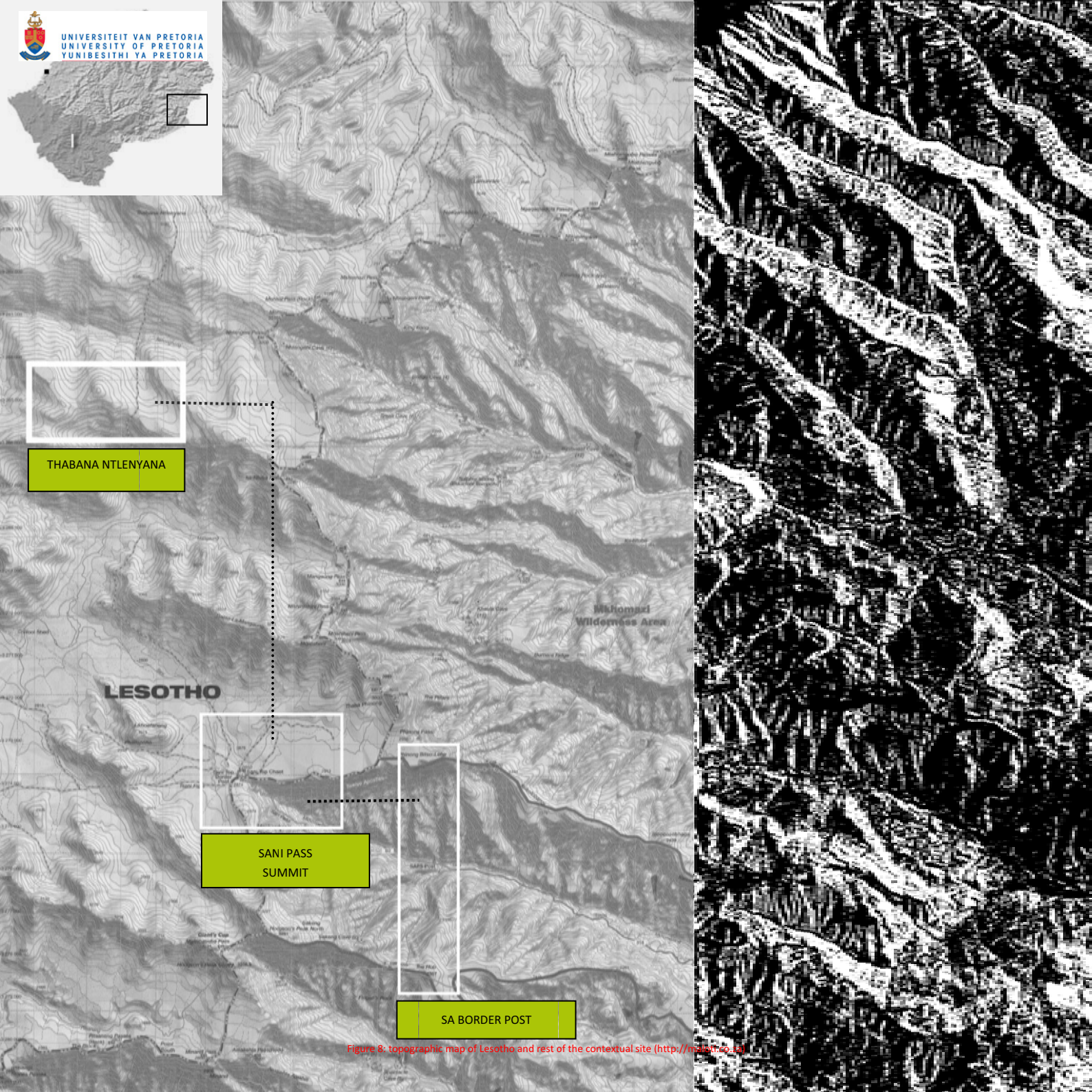

Figure 8: topographic map of Lesotho and rest of the contextual site (<http://maps150.co.za>)

## CONTEXT STUDY

### SITE

>> >

#### Lesotho\_

The only country in the world with all its land above 1000m (World Book, 1995). Lesotho is enclosed by South Africa along most of its border and shares a section of mountains, around the southern border, with Transkei. Lesotho lies approximately 320km (World Book, 1995) inland from the Indian Ocean. About two-thirds of the total land area is mountainous (elevation more than 3000m above sea level (Grolier, 1995), with higher elevations in the north-east and east. Along the eastern border of Lesotho, edging the central Drakensberg lays the highest peak in southern Africa: Thabana Ntlenyana at 3482m (Turco, 1994). A geological feature of the terrain is that all the rivers flow in the same direction due to the lower strata of sandstone that were uniformly laid in a north-easterly to south-westerly plan (Grolier, 1995).

Running north-east to south-west the Maluti mountain range dominates the western districts of the country, while the east is made inaccessible by the barrier of the Drakensberg. The Maluti Mountains in Lesotho and the adjacent Drakensberg range in South Africa are a unique but fragile ecosystem. The Maluti Mountains, in the central northwest are the source of two of South Africa's largest rivers – the eastward-flowing Tugela and the westward-flowing Orange River (Britannica, 1986). The Sani Pass forms a link between the Maluti Mountains and the Drakensberg Mountains. The Sani Pass is the only access from KwaZulu Natal to the Lesotho Highlands. The Route, aptly called the "roof of Africa", boasts to be the highest road in Africa and third highest in the world and peaks at a height of 3 200m above sea level (Sycholt, 2002). The Sani Pass summit lies within a couple of kilometres from Thabane Ntlenyana. Though fragile, this area is globally important as a centre of endemism, source of freshwater due to the unique wetland systems, as preferred area for nature based tourism and as a place of cultural significance (Turco, 1994).

Lesotho has a subtropical climate where the mean summer temperature is 15°C and the mean winter temperature is 3°C (Grolier, 1995), in the highlands of the northeast the temperature range is much wider, and frost and snow occur frequently. The Maluti Mountains and the Sani Pass are usually snow-capped in winter.

>> >

#### The Sani Pass\_

Currently a 33-kilometre gravel road traverses the sheer cliffs of the Drakensberg escarpment in a series of tight zig-zag curves - climbing more than a kilometre from the Sani Pass Hotel past the South African border post at 1 900m (Sycholt, 2002) to the Sani Pass Summit at 2 873m (Sycholt, 2002), used by taxis, tourists and 4x4 enthusiasts, it is this which Michael Clark wants protected (2006: 17).

Clark (2006: 11) also points out that the pass was originally used to bring goods on pack animals from South Africa to Mokhotlong in the "Mountain Kingdom"; the pass was only opened to vehicle traffic in 1955 and, despite improvements since then, remains extremely steep and rough (Clark 2006: 11).

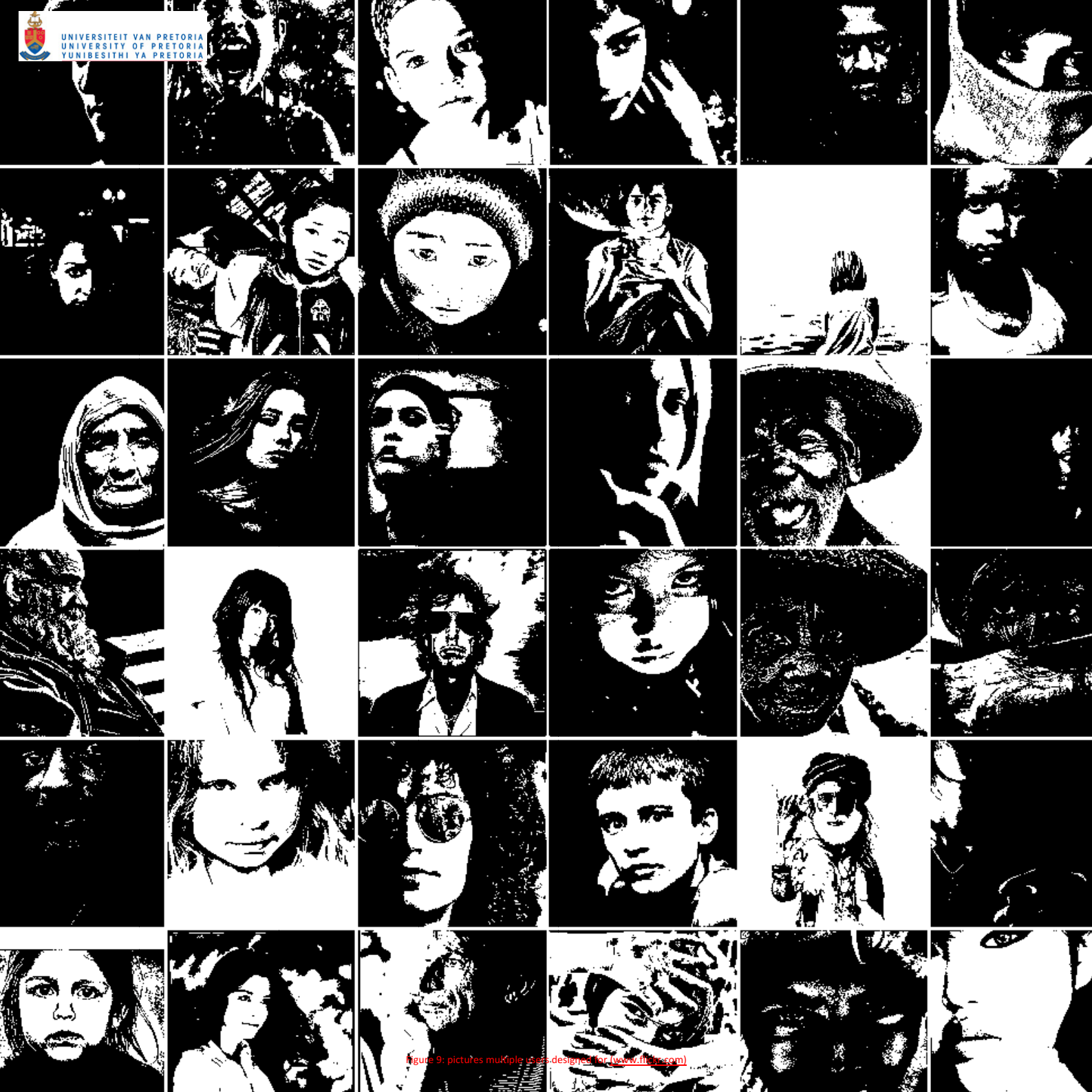

Figure 9: pictures multiple uses designed for [www.illustration.com](http://www.illustration.com)



The Lesotho Aerial Transport system will attract a variety of users ranging from the Basotho on his way home from work to foreigners seeking adventure. The funitel as well as the various terminals will have to cater for all types of users. By a thorough investigation of the demographics and visitor profiles of the identified areas, designers can predict what user type will form the majority and so allow the design to respond accordingly.

The transport system will be utilised by all types of users from various income groups; affluent, poor, local and foreign. The aim of the system is to replace the current futile taxi transport system and 4x4 vehicles with a more effective aerial ropeway system and progressively accommodate all the various activities such as communal transport, adventure and dwelling.

The user profile will be represented by:

- Local Basotho (all age groups)
- foreigners (all age groups)
- tourists
- elderly and disabled
- professionals
- workers
- students
- families
- dwellers/ adventurers

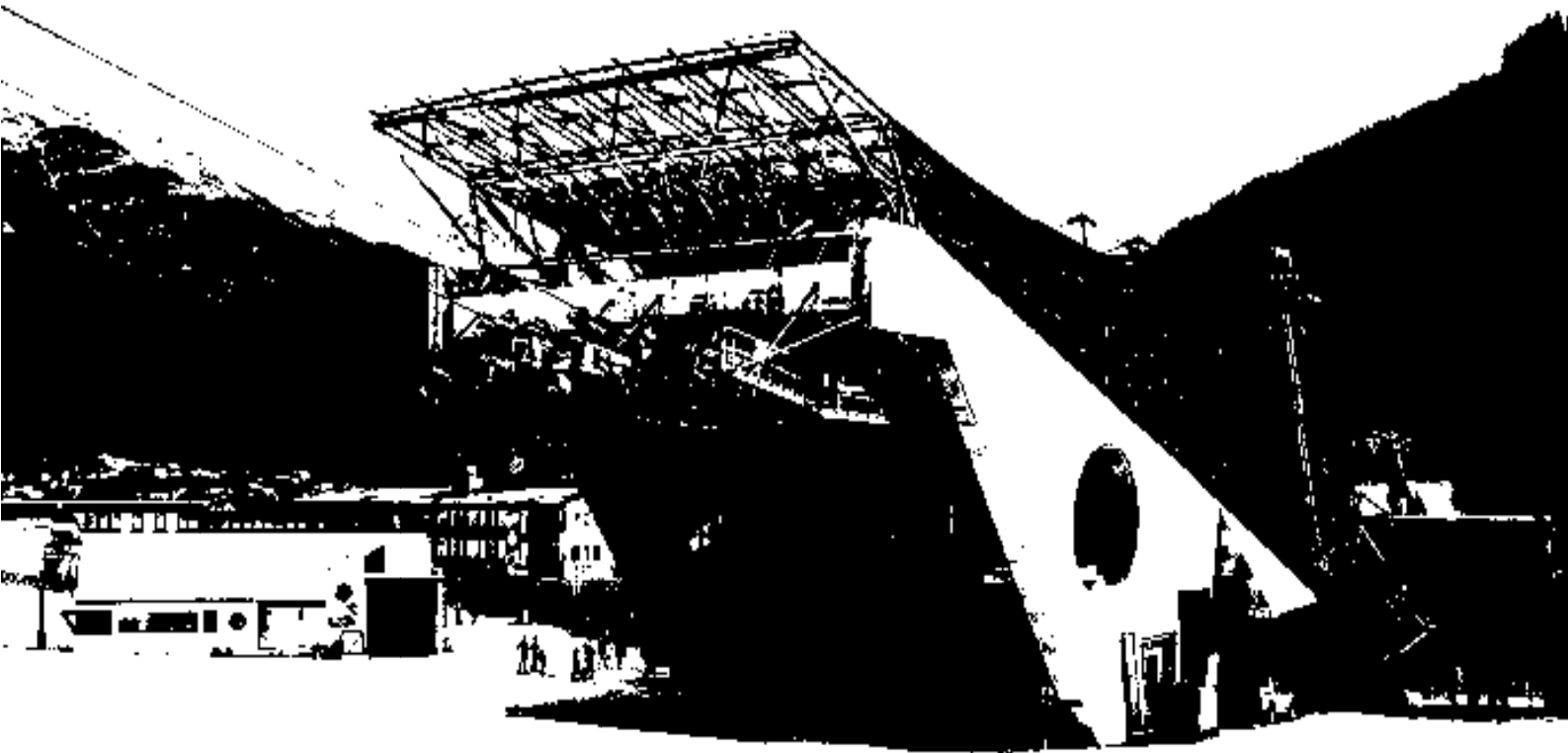

## PRECEDENTS

### GALZIGBAHN BY DRIENDL ARCHITECTS

>

Glass, steel, concrete - sober feedstock, yet sensual in its combination. The form of the new base station directly evolves out of the transport function it has to achieve. The desire for readability and transparency defines the material choice. Glass reveals technical inner life and previews the trip up to the mountain. Concrete grounds the construction, anchors it into the slope, creates a counterweight and is a carrier of a space truss (organized in triangulated bracing and as filigree as possible) which carries off the weight of the roof; the visible construction of the space truss (with its riggings and the chosen profiles) directly evolves from the prevailing wind and weather conditions, always standing in attention to defy wind, rain and snow-masses (<http://www.ropeways.htm>).

The funitel is coming from the hillside into the building and on a specially developed “Ferris Wheel” downwards, while the waiting passenger rises to the first floor. The passengers will be lifted by the funitel and float from the roof through a rural landscape across the glazed area to the Galzig (<http://www.doppelmayr.com>), with no constructive linkages clouding the panoramic view on the way up. Newly developed technology in people-transport sets examples for the future. What used to be bland construction without any design is now being put into the spotlight through architecture.

Georg Driendl Architects proceeded with their project as winner of a design competition. The new developments in cable-car technology – using “big-wheels” – make it much more comfortable for passengers to get onto the carriage and in this particular case provide a striking architectural accent in the village. The freestanding steel and glass structure sits on two stylish reinforced concrete walls and provides the envelope for the technology which is not fixed into the foundations of the building. Glass exposes the technical inner-life and gives the passenger from the outside a glimpse of what experience the mountain-ride will entail. The transparent, very dynamic structure which has triangular and rhombus shapes of glass covering the 2 200 m<sup>2</sup> completely enclosed skin, shapes the envelope to suit the technology inside (<http://www.driendl.at>). The architectural landmark in St. Anton encompasses the highest possible level of safety using STADIP laminated heat-strengthened glass (<http://www.doppelmayr.com>).

The highly strategic and technical design makes Galzigbahn successful; it is the stations exceptional flow and proportions which contribute to the success of the design. Apart from the effective structural system the approach to the user and the way the whole system is designed to enhance the user’s experience and commuting make this an approachable precedent.

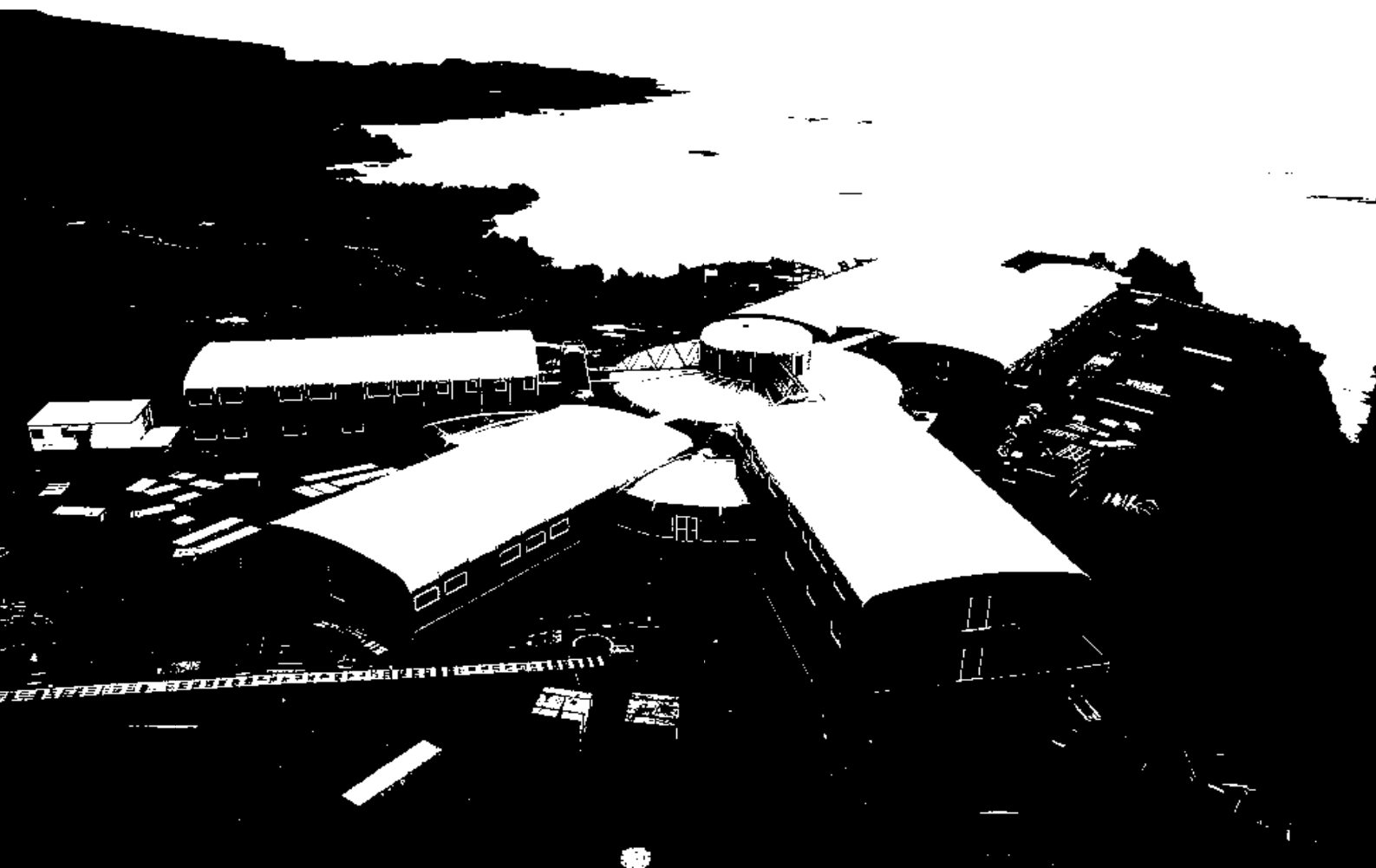

>

Marion Island is situated approximately 2 000 km southeast of Cape Point and still falls within the borders of South Africa. Communication between the island and the outside world can only take place via satellite.

Although the new base can accommodate 90 researchers, the researchers usually come in groups of 10 to 15, and stay for up to a year (Raath 2008).

Helga Raath (Raath 2008) explained that the research base consists of a working and living area constructed from moulded steel and fibreglass panels, which can withstand the extreme weather conditions. These extreme weather conditions entail temperatures varying between -15 to 10 degrees C with winds reaching speeds of up to 180 km per hour. The wind plays a major role with regards to the chill factor.

She also said (Raath 2008) that due to environmental concerns, concrete may not be mixed on Marion Island, which meant the base couldn't feature any bricks or concrete flooring. Special glass-reinforced plastic (GRP) - a type of fibreglass - boasting good insulation properties, was used for all the panels. These panels were designed and manufactured in South Africa, from where they were shipped to the island. This was achieved through extensive research and testing to create the product most suitable to the conditions. Other features of the base include covered walkways and hallways between the climate-controlled buildings, because of the adverse weather. People can move between the buildings without being exposed to the weather (Raath 2008).

The Marion Island base is now being replicated by other overseas designers for bases in the Antarctic, and similar harsh environments.

The design seemed very relevant in the way the architecture responded and communicated the harsh climatic conditions on Marion Island. The GRP selected has great climatic response and helps in maintaining a comfortable core temperature; it thus assists in the homeostasis of the relatively small living spaces.

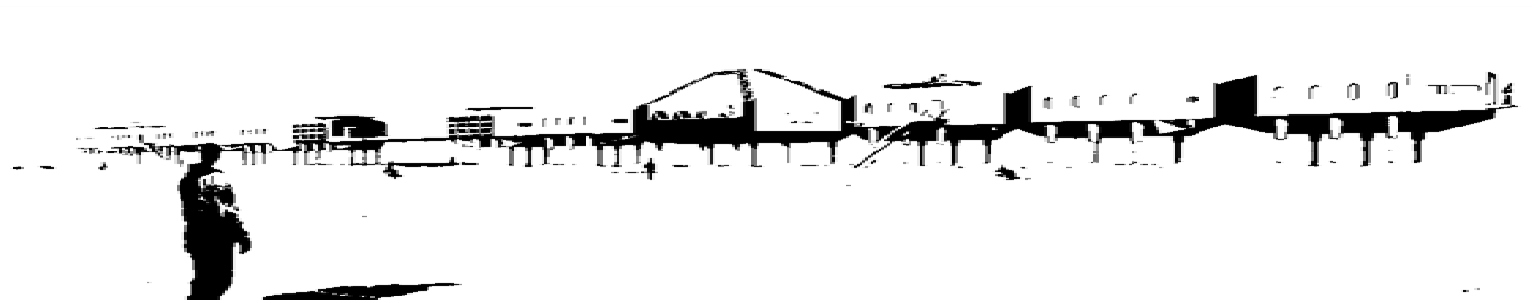

ANTARCTIC HALLEY VI  
by Faber Maunsell and Hugh Broughton Architects  
GRP-modules

>

Situated on the Brunt Ice Shelf, Halley is the remotest of the British research stations. Halley was first built in 1956 and has since been rebuilt four times. During the summer months about 65 people live and work at Halley V, but for nine months of the year, the research station is completely cut off from the outside world. Fifteen or so people brave it out during the winter when temperatures can fall to -50°C and there is almost 24 hour darkness for three months (<http://www.discoveringantarctica.org>).

Design plans for Halley VI are both groundbreaking and futuristic. Thanks to special mechanical legs that will act like skis, Halley VI will be able to move with the ice, and be towed to different positions on the ice shelf, dramatically increasing its potential lifespan (Raath, 2008).

The central area of the research station itself will be available for recreation and relaxation. On either side, a platform will link together detachable 'modules'. Some of the modules from the north platform will provide accommodation all year round, with each big enough for eight bedrooms. On the south platform, the modules will be used for science laboratories and extra accommodation during the busy summer months (<http://www.discoveringantarctica.org>).

The new station will provide a home and work place for the people during the winter and in the summer and needs to respond to some awesome environmental challenges. Located 10,000 miles from the UK, the station will be located on a 150 metre thick floating ice shelf, which moves 1 km per annum towards the sea (<http://www.hbarchitects.co.uk>).

Snow levels rise by around 1 metre and the sun does not rise above the horizon for 100 days per year (<http://www.discoveringantarctica.org>). The new self-sufficient complex will replace the current Halley V Research Station and will be relocatable. Designed to withstand extreme winds and freezing winter temperatures of around -50°C (<http://www.discoveringantarctica.org>) The new prefabricated modular research station features a dramatic central social and recreational module. The station is designed to adapt to the changing external conditions and future science needs of BAS .

As with Marion Island the material selection was based on strength, core temperature comfort and durability. The ease with which various panels can be manufactured and assembled seemed a reachable goal for any design. The design succeeded in keeping assembly simple without limiting the creative mind.





## CONTEMPORARY ART CONTAINER BY ZAHA HADID GRP-modules

>

The container, discussed here is in Hong Kong, the first of six cities on its world tour, houses commissioned artworks that reinterpret the label's iconic 1955 quilted bag, and was designed by Zaha Hadid for fashion house Chanel (<http://www.ihalife.htm>).

Due to the nature of the pavilion's geometry, two sections will be different even if only 10 cm apart. Hadid's office models whole buildings in 3D and sends the computer files to the engineer and then on to the main contractor, who builds from them directly. A practice's software models the thickness of all materials (<http://www.thecoolhunter.net>). Additionally, it can include a material's properties such as minimum radiuses from early on in the design process, making it impossible to generate unbuildable geometries. For architects so involved in exploring fluid geometries, this new shamelessness between form-making and engineering has already become essential to the studio's output. (MMS technologies use "Solidworx" for this same purpose.) All the wall panels are made from two skins of fibre-reinforced plastic (FRP), which has a very strong tensile strength (<http://www.chanel-mobileart.com>). Between these is 2.5 cm of glass fibre foam core that creates a structural depth to help deal with acoustics, gives a solid rather than a hollow sound to help with the sensuality of the material. The same detail that attaches the FRP panels to the pavilion's I-beam structure is used during transportation to fix them to scaffolding that goes directly into a 2.5 m-high x 6 m-long sea container. The pieces are fixed in place one above another. In much the same way as precious artworks are transported, they aren't wrapped — not even bubble-wrapped — to prevent surface scratches to the glossy, spray-painted finish. (<http://www.thecoolhunter.net>)

## ZARAGOZA BRIDGE PAVILION BY ZAHA HADID GRP-modules

>

Zaha Hadid has chosen glass fibre reinforced concrete from the Austrian company Rieder to envelope the 275 meters long "Zaragoza Bridge Pavilion", the new symbol of the Expo 2008 in the northern Spanish Zaragoza: she has covered the outer skin of the building with 29 000 triangles in different grey shades out of fibreC (<http://www.dezeen.com>). The new bridge across the river Ebro is entrance to the Expo area and at the same time multi-level exhibition area; 10 000 visitors per hour will frequent the Main Pavilion of the world exhibition (<http://www.dezeen.com>).

Apart from its design and visual impact, the design has a strong sustainable component reached through material selection. The composition of fibreC out of degradable, purely mineral raw materials entirely complies with the current trend of natural, environmental-friendly and sustainable materials (<http://www.dezeen.com>). Opposite to the Expo-Theme, sustainability has been certified in May according to DIN EN ISO 14.001 (<http://www.tuvie.com>). With this "organic approach", Zaha Hadid's design of the bridge as well as the use of the material fibreC fit with the EXPO theme "Water and Sustainable Development". The innovative material fibreC enables big creative freedom in terms of mouldability, colour and processing (<http://www.tuvie.com>). Today, fibreC meets architectural challenges, which apparently made it impossible to employ concrete even a few years ago (<http://www.ihalife.com>).

Both the Mobile Chanel Exhibition as well as the Pavilion Bridge made use of the very lightweight and durable GRP material. What one really grasped about the material from these two designs, is the absolute endless possibilities of shapes and spaces reachable by using GRP.



>

'PUYO' is a Japanese onomatopoeia that expresses the sensation of touching the vehicle's soft body. It is meant to convey a warm, friendly impression (<http://world.honda.com>). The PUYO represents a new idea in mobility that brings together 'clean', 'safe' and 'fun' functionality in an environmentally responsible, people-friendly minimalist design featuring an ultra-high efficiency, small frame and fuel cell technology to please both users and onlookers alike (<http://world.honda.com>).

### **Interior design**

>

Developed to have a 'Silky Feel', the PUYO's interior is designed to provide a refreshing, people-friendly space imbued with a feeling of transparency. Features such as an instrument panel monitor, controls that take advantage of the elastic qualities of cloth to rise up when the vehicle starts up, luminous fluid meter displays, and a joystick for intuitive operation are all designed to gently support occupants' senses and sensibilities (<http://world.honda.com>).

### **Exterior design**

>

The development theme for the PUYO exterior was to create a cornerless, 'Seamless Soft Box' form that is kind to both people and the environment. The goal was to create a personable design with the feel of an adorable pet, while taking advantage of the maximum spaciousness of the box-shaped design. The PUYO's 'gel body' features soft materials to promote greater real-world safety. Moreover, the body has been made luminescent to guide people into the proper operating position and notify them of the vehicle's condition, facilitating a more intimate relationship between people and their cars (<http://www.hydrogencarsnow.com>).

The car posed to be a design anomaly and through expert material selection the Japanese really succeeded in capturing the world. The vehicle design was based on all the individuals' senses and they considered every stage of commuting and driving. The vehicle has a material richness with isoskin, elastics and transparency it also has advanced technological features which makes it a liberating precedent.



## Definition

>

An aerial ropeway is defined as:-

"Any apparatus for the overhead transport of passengers or goods in carriers running along or drawn by overhead cables supported by towers, pylons or other similar structures, together with any machinery, equipment or plant connected therewith."

(N.B. this Code of Practice will not deal with ropeways or lifts used for industrial purposes).

## Planning

>

When planning the location and route of an aerial ropeway the following factors must be carefully considered:

### (a) Amenity Value

The aerial ropeway including any further extension shall be so located that adequate facilities for inter-connecting public transport are available at the terminals.

### (b) Route

An aerial ropeway including any future extension shall be routed so that its effect on the environment is minimal; this involves consideration of noise pollution, unsightly construction and any detrimental visual impact on the local environment. In the design of the routing of the aerial ropeway or its extension, due regard shall be given to the effect on/from existing neighbouring build-up areas or natural habitat, such as vegetation, roads, railways, aircraft flight paths, electric power lines, streams, buildings, bridges and slope stability. An environmental impact assessment shall be carried out to address this subject in accordance with any other legislative requirement in force in Hong Kong. Adequate consultation on various details of the project shall be conducted with relevant organizations and the local community. If land resumption is a related issue on the project, all necessary procedures as required by any other legislative requirement in force in Hong Kong shall be followed.

### (c) Emergency Access

Adequate access to terminal stations by emergency vehicles as may be required by the Director of Fire Services (abbreviated to "DFS") shall be provided. A rescue plan shall also be drawn up in consultation with DFS and the Director to deal with emergencies during operation.

## 1. GENERAL DESIGN

>

Every part of an aerial ropeway system and its associated equipment shall be designed with consideration given to the safety of the passengers, general public and operating staff, and shall be designed in compliance with this Code of Practice.

>

All systems must be designed, operated and maintained in accordance with the following principles of safety, which are to be applied in the order given:

\_ Eliminate or, if that is not possible, reduce risks by means of design and construction features;

\_ Define and implement all necessary measures to protect against risks which cannot be eliminated by the design and construction features;

>

Because of the high probability of any structure in Lesotho being subject to severe winds and very heavy rainfall, the design of any exposed equipment and the selection of any materials used in the construction of an aerial ropeway shall give due regard to these factors.



Figure 16: strong alloy structure, enhancing safety (Louw: 2004)

## 2. CARRIAGE CONSIDERATIONS

>

### Carriage Parameters

>>

All carriages must comply with some basic design requirements which are detailed below:

- > 01 Each person shall be in general assumed to be equivalent to a 75 kg mass (Rudolph, 2007).
- > 02 Standing passengers are allowed if the carriage is suitably designed for that purpose (Rudolph, 2007).
- > 03 The boarding time for each carriage shall be assumed to be 3 seconds per person up to 10 persons and 1.5 seconds per person thereafter (Rudolph, 2007).
- > 04 The safety factor of the structure, hanger and all load bearing components shall be at least 4. (10 mm grp: safety factor 10) (Rudolph, 2007)
- > 05 The design calculations shall take into account all probable static and dynamic forces that will be encountered in operation (including fatigue loading), such as vehicle weight itself, passenger load, wind force, inertia forces at trestles, starting acceleration and braking (Rudolph, 2007).
- > 06 The enclosure of the carriage shall be so designed as to prevent the passengers from being thrown out in case of accident and must have the facility to prevent passengers from getting out of a closed carriage. Also, all doors should be closed, either manually or automatically, from the outside and shall not be opened from inside the carriage except by the attendant in the case of an attended carriage (Rudolph, 2007).
- > 07 All carriages shall have adequate natural ventilation. The transparent material for the window opening shall be shatterproof (Rudolph, 2007).
- > 08 **Minimum sizes for carriages** (Rudolph, 2007)
  - For standing passengers:  
Floor area  $A = N/6 \text{ m}^2$   
(N = number of passengers)  
Height H = 2.0 m
  - For seated passengers:  
Seat width W = 0.5 m  
Floor area A =  $0.33 \text{ m}^2$  (per passenger)

>

### Speed (Rudolph, 2007)

- > 01 As the ropeway technology develops there will be a natural increase to the maximum permissible speeds. The variation of speed of vehicles due to either acceleration or deceleration shall not cause disagreeable sensation to passengers. This development will not be discouraged although the recommended safe maximum speeds at the present time will be:
  - Monocable (closed carriage) 4.0 m/s
  - Monocable (open carriage) 2.0 m/s
  - Multi-cable (with one rope for supporting purpose) 7.0 m/s
  - Multi-cable (with more than one rope for supporting purpose) 8.0 m/s
  - To & fro (attended carriage) 12.0 m/s
  - To & fro (unattended carriage) 8.0 m/s
- > 02 When carriages are in constant motion for loading and unloading the maximum speed shall not be greater than 0.25 m/s and the detached carriages will be stationary during loading and unloading to limit safety risks.
- > 03 It should be re-emphasized that the maximum speed of any system must be designed with safety in mind. Ropeway engineers will specify all this.



Figure 17: a typical terminal with proper signage and safety (Louw: 2007)



### 3. STATIONS

>

#### Structures

The building structures and facilities shall be constructed in accordance with the requirements as stipulated in the Buildings Ordinance for Aerial Transport Systems. The designs of the terminal buildings shall take account all the forces upon them, including rope tensions and an earthquake loading (Rudolph, 2007).

>

#### Access

Queuing area shall be provided at each terminal for passenger boarding. The queuing area shall be sufficiently large to cater for the maximum passenger flow.

The layout and deposition of the stations shall be such that the access and exit points are clear, even at times of maximum passenger flow. The circulation of passengers is, as far as possible, unhindered. Sufficient covered space shall be provided, under average passenger flow conditions, for waiting passengers.

>

#### Prohibited Areas

Passengers shall not have access to any area housing machinery or operational equipment and shall be given access only to the boarding and alighting areas.

All machinery and equipment shall be adequately guarded with noise attenuation facilities. The driving gear and the return deflection devices shall be protected against weather.

>

#### Boarding Area

At boarding areas in those stations where the carriages are in constant motion, enough space to accommodate the passengers queuing up for boarding the carriages shall be available. In all cases, sufficient space shall be provided, under average passenger flow conditions, for waiting passengers under cover or shelter from the weather. Sufficient public hygiene facilities shall be available at all times.

>

#### Emergency Lighting

Emergency lighting in the terminals or other stations for passenger boarding shall be available from a secure supply. Such supply should conform to the Code of Practice for Minimum Fire Service Installations and Equipment and Inspection and Testing of Installations and Equipment issued by Fire Services Department.

>

#### Prevention of Fire

Upon receipt of building plans, Director of Fire Services will be responsible for formulating requirements/recommendations for the intended use of such terminals and/or stations. In addition, proper management of terminals and/or stations with specific reference to good housekeeping, effective control of passengers, unobstructed entrances/exits, etc. are essential for prevention of fire. Any such requirement of the Director of Fire Services shall be complied with (Rudolph, 2007).

>

#### Notices

The following notices shall be posted in a conspicuous place in each terminal and station and shall be kept in good condition:

- > 01 Notices, in both Sotho and English, containing the messages as required in the Regulations and, in addition, giving warning of hazards related to moving machinery, and
- > 02 Notices, in both Sotho and English, and either with a red or yellow background, giving warning of the danger of fire in the terminal/station, as well as in the vicinity of the ropeway line.

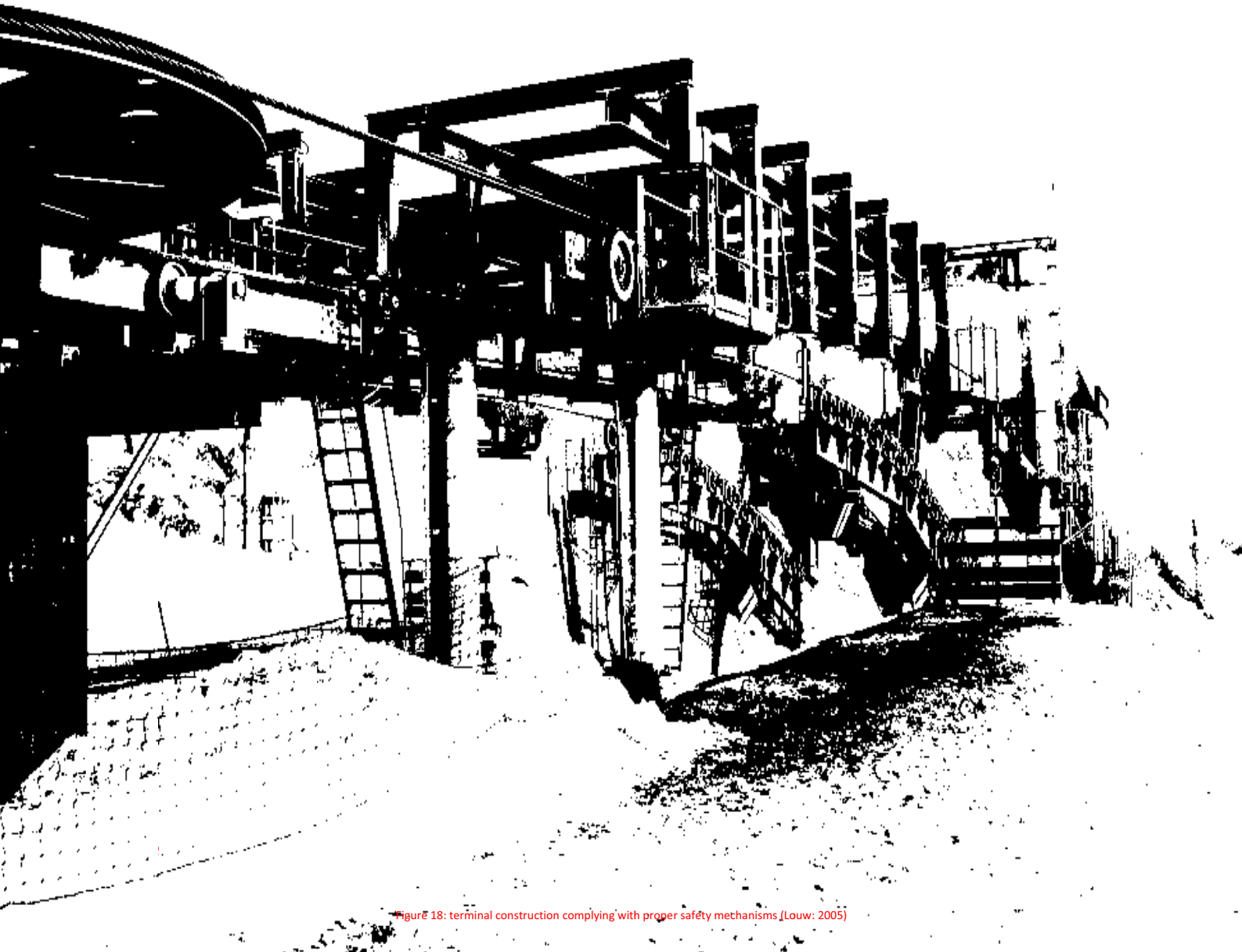

Figure 18: terminal construction complying with proper safety mechanisms (Louw: 2005)

#### 4. CONSTRUCTION CONDITIONS

>

##### Route

In Lesotho, the probability of having strong prevailing wind at the site where the aerial ropeway is going to be installed is high. To determine the wind effect on the aerial ropeway, a full scale in-situ investigation shall be conducted prior to the detailed design of the aerial ropeway. The duration of the investigation shall be sufficient to determine the seasonal fluctuation of the wind direction and magnitude. The design of the aerial ropeway shall cater for the wind effect obtained in the full-scale in-situ investigation. The engineer will do this.

A geotechnical assessment of the proposed route should be carried out, based on which a site investigation programme should be designed and implemented (Rudolph, 2007). The design of aerial ropeway foundations shall be in accordance with the requirements of the Geotechnical Manual for Slopes (Rudolph, 2007) and shall be submitted for approval to the appropriate government department or office as required by legislation or the design brief. The aero view route of an aerial ropeway should be straight

>

##### Profile

The profile of the aerial ropeway (longitudinal side elevation) shall be, as far as practicable, parallel to the terrain over which it passes (Rudolph, 2007).

>

##### Integrity of the installation

- > 01 The aerial ropeway shall be designed and constructed in such a way that, while in operation, any failure of any component will not affect the safe operation of the aerial ropeway and will not cause other components to fail (Rudolph, 2007).
- > 02 All components of the aerial ropeway shall be properly designed to facilitate routine monitoring and maintenance in order to avoid failure (Rudolph, 2007).
- > 03 The operation of the aerial ropeway shall be able to be stopped manually at any time (Rudolph, 2007).

#### 5. COMMUNICATIONS

>

There is a constant need to maintain adequate verbal contact between the terminals and the passengers or other operational staff on board of the carriages, especially at times of emergency (Rudolph, 2007). Therefore, the following forms of communication equipment shall be provided to ensure that effective communication is available at all times .

>

##### Telephone

All terminals shall be connected to the public telephone service. In addition to this requirement, an internal telephone system connected to the major sections of the ropeway is required.

>

##### Wireless Communication System

A wireless communication system, approved by the Director-General of Telecommunications, shall be provided. The system shall not interfere with other similar systems in Lesotho. For the aerial ropeway with attended carriages, a wireless communication system shall be provided at the carriages for the communication between the carriages and terminals.

>

##### Public Address System

The line of a multi-carriage aerial ropeway shall be provided with a public address system that is audible within the carriages from any point on the line. In addition, portable loud-hailers are recommended for 'on-the-spot' communication in case of emergency. At least one of these modes of communication shall be readily available at all times. Any cables that are also used for the transmission of any electrical systems shall be suitably protected and isolated.

TERMINAL 1  
ON  
OFF      Off

TERMINAL 2  
Off  
ON      ON  
Off

TERMINAL 3  
Off      ON

>> SA Border Post  
1968m

Terminal 1 to terminal 2  
8km  
18 minutes  
(3 hours by car)

>> Sani Pass Summit  
2873m

Terminal 2 to terminal 3  
21km  
47 minutes

>> Thabana Ntlenyana summit  
3482m

Total trip time (one way)  
29km

65 minutes

Total trip time (two way)  
58km

Figure 19: proposed terminal layout and data

## CONCEPTUAL THINKING

### TERMINAL ANALYSIS AND PLANNING

A thorough Environmental Impact assessment has revealed that the impact of a dirt road is less on the ecological milieu than that of a tar road and the impact of an aerial transport system is five times less on the same ecological milieu than that of the dirt road. An Aerial Transport System has thus been proposed to replace the current dirt road and hence limit the impact on the mountain ecosystem and increase ecotourism. The transport system with accompanied structures will also create employment, both during and after construction.

The proposed Aerial Transport System will start from the SA Border Post (TERMINAL 1 – 1 968 m) (Turco, 1994) Sani Pass Summit (TERMINAL 2 – 2 873 m) (Turco, 1994) to Thabana Ntlenyana (TERMINAL 3 – 3 482 m) (Turco, 1994). It will be 8 km (was 33 km by car) from terminal 1 to 2 and another 21 km from terminal 2 to 3, making the total trip 29 km, approximately one hours' ride in one direction. If the funitel moves at 7.5 m/s (27 km/h):

	DISTANCE	TIME TRAVELLED
Terminal 1 to terminal 2	8 km	18 minutes
Terminal 2 to terminal 3	21 km	47 minutes
Total trip time (one way)	29 km	65 minutes
Total trip time (two way)	58 km	130 minutes

Table 1: Terminal design and distances travelled

### TERMINAL PROPOSAL

The Doppelmayr/Garaventa Group is the world quality and technology leader in ropeway engineering (Rudolph, 2007). The Group develops efficient passenger transport systems for summer and winter tourism resorts as well as state-of-the-art passenger transport systems for the urban environment, airports, shopping malls, sports complexes, adventure parks, trade fairs and other facilities with corresponding transport requirements (Rudolph, 2007) Commuters usually have to access a carrier via a flight of stairs, which could be a rather laborious trek for commuters with backpacks, bicycles, canoes, skis or luggage. To facilitate access for commuters the group have engineered a big wheel solution (view attached CD) for a cable car. The funitel enter the terminal at an upper level, are taken down to the level below (entrance level) by means of a big ferris wheel and then follow a gentle curve through the loading and unloading area at creep speed until they are finally raised back up to the station exit by a second big ferris wheel, from where they are launched onto the line. The commuters thus come off the trail and board the funitels at ground level.

A special feature of this system is the double configuration of the rope loop: one continuous rope produces four rope lines. There are two parallel ropes on both the uphill and downhill sides. The drive is via a vertical bull wheel (ca 5.2 m). The central counterweight tension system operates via three bull wheels on a common movable carriage (Doppelmayr has also used hydraulic tension systems on other funitels). In the station curves, the funitels are transported along running rails by means of tyre conveyors. The entire ropeway machinery is fixed to the roof beams of the building. No central columns are required which would hinder the flow of the commuters (Rudolph, 2007)

## CORE SYSTEM analysis

. funitel

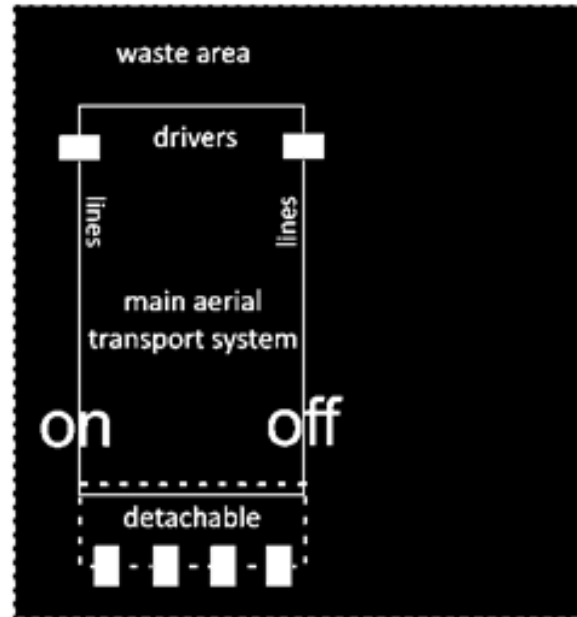

- . visibility
- . signage
- . branding
- . colour
- . understandable
- . functional
- . efficient
- . paraphernalia loading
- . paraphernalia offloading

- . engineered structures
- . supporting engineered structures
- . commuting spaces
- . restaurant
- . toilets
- . kiosk
- . information
- . ticket booths
- . control point
- . waiting areas
- . shops
- . atm
- . local trade
- . donkie stop
- . parking
  - . cars
  - . taxi's
  - . busses

### ADVANTAGES OF AERIAL TRANSPORT SYSTEM:

- > work/business opportunities
- > minimal environmental impact
- > multi-functional transport system
- > seasonal adaptable transport system
- > tourist attraction
- > affordable transport
- > safe transport
- > effective all-round transport
- > environmentally friendly transport
- > enhances local economy
- > supply remote areas with power

Figure 20: terminal design considerations and system analysis planning

The terminal 1 will consist of two commuting levels.

On both levels all facilities and doorways should be clearly visible and reachable. The design should enhance movement and not create confusion or friction within the flow. Boundaries, subsets and clear signage should direct and guide the user indefinitely. Zones will be allocated so that the commuter can be directed without difficulty, this will also make ticketing and terminal mapping more effective. The same zone-principles will be applied on both ground level and the first level. By applying these principles one will induce a system with useful indicators **dep0A, dep0B or ar1A, ar1B** applied onto signage, mapping and ticketing.

ZONE 0 >> ground floor

> DEPARTURES

People will enter the building at ZONE 0 from where they can proceed either to the recreational space (local craft), toilets or board the carriage which will take them up the pass to terminal 2 and hence terminal 3. The departing level should be designed so that all the various facilities and operating structures should be visible and reachable.

There will be two definite boarding zones.

Zone A will be for immediate boarding where the cable car is still creeping through the terminal and commuters board while the cable car is in motion.

Zone B will be for prolonged boarding where the cable car is detached and loading of paraphernalia (suitcases, stock, trade, equipment, canoes, bicycles, pushchairs and wheelchairs) will proceed while commuters board.

ZONE 1 >> first floor

> ARRIVALS

There will also be two definite disembarking zones:

Zone A will be for immediate disembarking where the cable car is still creeping through the terminal and commuters get off while the cable car is in motion.

Zone B will be for prolonged disembarking where the cable car is detached and off-loading of paraphernalia (suitcases, stock, trade, equipment, canoes, bicycles, pushchairs and wheelchairs) will proceed while commuters disembark from the carriage.

People will disembark from the carriages on ZONE 1 from where they can progress either to the restaurant, shops, and toilets or exit the building.

The Doppelmayr/Garaventa "ferris wheel" system (as discussed) will be implemented. The above mentioned zoning will be then designed around the functioning engineered structures.

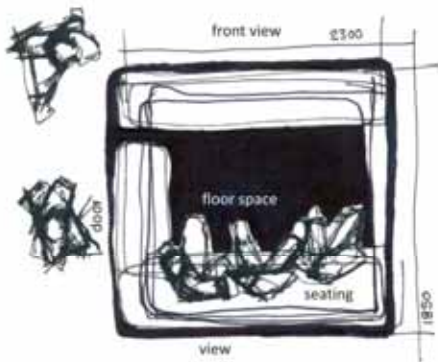

CARRIAGE LAYOUT 1  
on plan

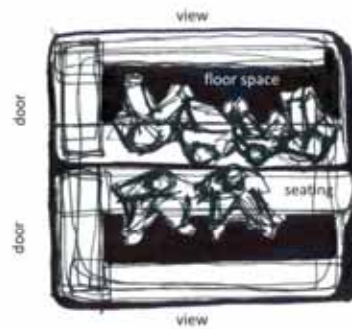

CARRIAGE LAYOUT 2  
on plan

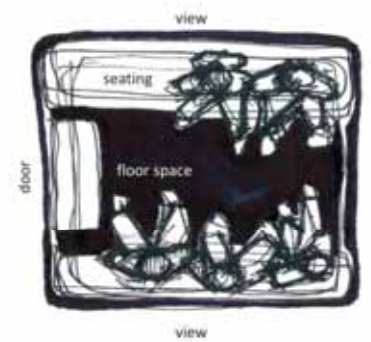

CARRIAGE LAYOUT 3  
on plan

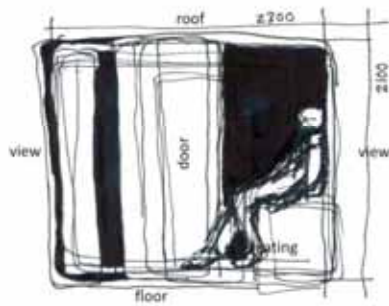

CARRIAGE LAYOUT 1  
on elevation

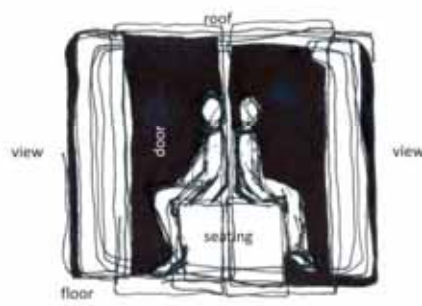

CARRIAGE LAYOUT 2  
on elevation

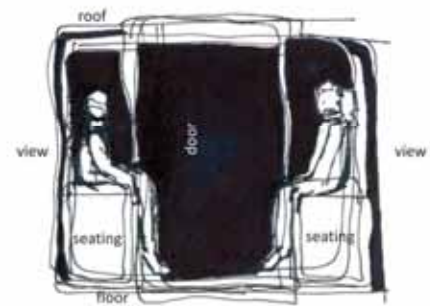

CARRIAGE LAYOUT 3  
on elevation



A range of suspended cable vehicles exist each designed to function within a specific context. Gondolas, funitels, funifors and reversible ropeways are the most general and known vehicles found. All of them have the same distinguishable silhouette and variation is expressed in colour and branding. Each of the above is described in the Appendices 1: Terminology section. A ski terminal or urban transportation terminal will either have a standard seating unit where all 100 units are the same or a standing unit where all the units are standing, but within a single terminal there will never be a combination of both seater and standing units. Below is a brief discussion of the standard seater and standing vehicles.

#### Interior of the “seating unit”

>>

These high performance structures are usually made out of a light alloy corrosion-resistant framework which is connected to a hanger with equipped shock-absorbers. The body is also made of an alloy metal and some of its components are made out of leather, a composite or a rubber to ensure shock resistance and thermal insulation ([www.poma.net](http://www.poma.net)). These materials allow partial repairs at low cost. The cabins are designed to provide a functional cabin. In addition the sets are shaped and arranged to give the passengers room to move around the cabin with ease. The vehicles usually have a double swivel-arm door for easy access (Rudolph, 2008). The vehicle has a textured aluminium floor surface and an alloy ceiling. An alloy ski holder is fixed to the doors and the commuter places his skis or snowboard inside the holder as he enters the vehicle.

#### Interior of the “standing unit”

>>

These units have exactly the same material silhouette as the seating unit but the whole interior space is empty and a 360° tubular handrail is the only addition to the interior ([www.poma.net](http://www.poma.net)).

These vehicles are usually 2080m x 2320m in width and allows for a head height of 1850m ([www.poma.net](http://www.poma.net)).

#### In conclusion

>>

By understanding the standard system and entity the designer can rethink the space, function and materials currently in use. By realising the importance of the user and understanding how the existing vehicle work one can respond by utilizing new sustainable materials and applying inclusive design principles.

NEW CARRIAGE TYPOLOGIES

STANDARD  
CARRIAGE LAYOUT  
on plan

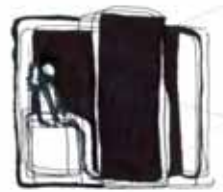

STANDARD  
CARRIAGE LAYOUT  
on elevation

10 (+1)  
STANDING  
UNIT



METAMORPH 1  
CARRIAGE LAYOUT  
on plan

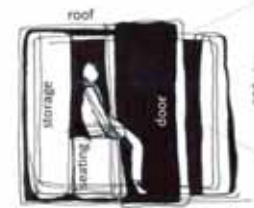
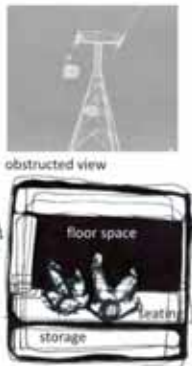

METAMORPH 1  
CARRIAGE LAYOUT  
on elevation

4/5 SEATER  
UNIT



METAMORPH 2  
CARRIAGE LAYOUT  
on plan

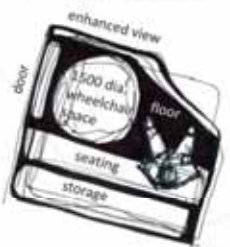

METAMORPH 2  
CARRIAGE LAYOUT  
on elevation

2 + (2)  
"PIC-NIC"  
UNIT



Figure 22: carriage design, ergonomic application and planning

The current design consists of three basic layouts:

Layout one >>

A row of seats is placed along one vertical plane of the vehicle and the user has a 360° view to the outside. This layout has an uncomfortable space in front of them and a lot of wasted surface and space. (figures 20,21)

Layout two >>

The seats are placed along the central axis of the vehicle (back-to-back) and the user has a 180° view to the outside. In this layout one has effective utilization of the interior space and the unit can transport more commuters per hour than layout 1. (figures 20,21)

Layout three >>

Two rows of seats are placed opposite each other. Even though this layout exploits the space fully the users face each other and their theoretical 180° view is obstructed. (figures 20,21)

The above layouts are all a four-sided entity with four corners a 0° horizontal top plane (the roof) and a 0° horizontal bottom plane (the floor). The above mentioned views are only applicable on a horizontal plane when the vertical plane of sight is considered, the reader will note that the standard cable car only allow a 180° view (ground to sky) when the user are directly next to a window. In all other scenarios the user has a 35° - 45° vertical plane view. (figures 20, 21)

The actual design proposal

On plan >>

Responding on layout 1:

One can utilize the wasted space by moving the row of seats forward in order to create a storage space behind the seats.

Due to the spatial compression one has left little room for wheelchair movement and the space can become inclusive by protruding out of the anterior plane and enlarging the space to allow for all users (inclusive 1500mm Ø). The unit are then rotated 35° horizontally so that the towers no longer visually pollute the view but the user can now gaze past the towers onto the landscape. (figures 20,21)

In section >>

Responding on layout 1:

All the spatial changes on plan will be visible in section as well. The altered unit are then rotated 25° on the vertical plane, this rotational change will also enlarge the current 35° - 45° vertical plane view to 60° - 70° vertical plane view (figure). By enlarging these visual spaces one create the illusion of a bigger inner context and the user starts to experience the real larger context

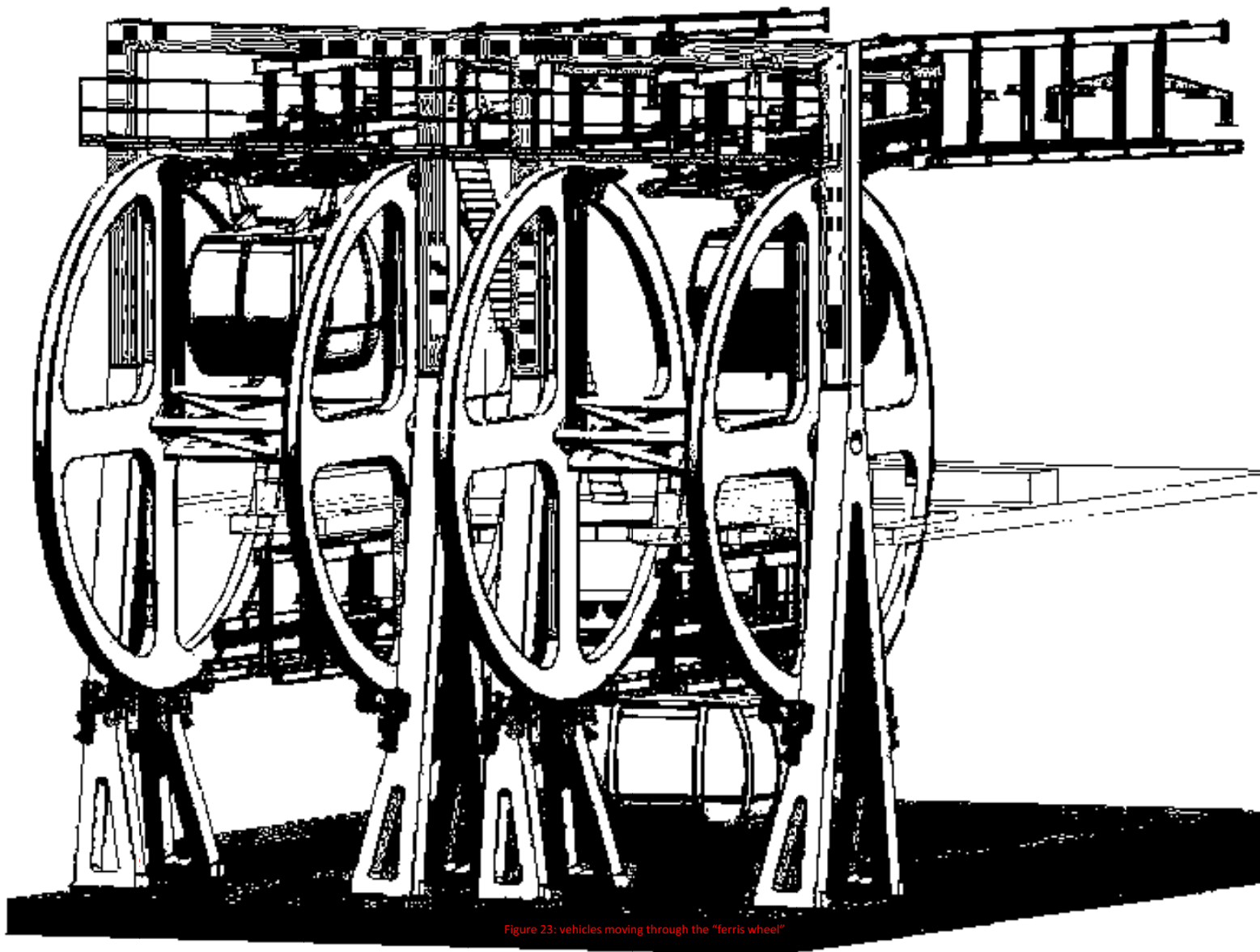

Figure 23: vehicles moving through the "ferris wheel"

.In general >>

The design should be adaptable and accommodate users and activities during summer, autumn, winter and spring. By having a single unit which can change in accordance to the need/activity of the user on can house all the mentioned activities. The concept is thus having one single shell, which can metamorph into a standing, seating or 'pic-nic' unit. By having clip-on or slip-in mechanisms, various structures can be attached or removed in order to house the different activities as the climate changes through the year.

the cabins can be adapted to meet the customer's specific requirements, including:

**technical features:**

- ventilation, radio, lighting, passenger handrails or hangrails , ski-holders, bicycle holder, storage compartments, etc.

**aesthetic design:**

- wide choice of colors (plain or two-colored),
- customized interior trim and decoration.
- Recyclable interior components

A long-travel suspension system installed above the extruded, riveted aluminum sections forming the structural framework ensures optimum comfort for passengers. The windows are made from PMMA with UV-filters. Cabin design provides operating personnel with immediate access to inspection points. The door opening/closing mechanism should be inserted in a compact, removable box and combines the door closing and locking functions.





## DESIGN DISCOURSE

### PRODUCT DESIGN

>

A product can be physical or metaphysical. This dissertation attempts to uncover the generic ideas behind the design of products while identifying physical and intellectual issues pertaining to industrial product design. Slack states (2006: 7) that a product design is an ambiguous idea that blurs the boundaries between specialist fields of lighting, furniture, graphic, fashion and industrial design. Perceptual and physical boundaries constantly erode as global communication improves.

Designers should clearly identify the relations between the past, present and future, and the potential effects of political, social and emotional influences within their environment. Technological developments in logistics and information systems bring global neighbours closer to each other and enable them to communicate and exchange cultural values through many vehicles of expression.

Products are designed with particular considerations valued by the designer, client, or end user that are then communicated through the products' purchase and use. Product life cycles shorten as fashion and technological improvements affect our product selection criteria.

### NEW DESIGN: AN ERA OF HYBRID PRODUCTS

A hybrid product is formed when two or more objects are merged to create something new, but still has visible references to a past life (Slack, 2006). The act of hybridizing is a provocative way of questioning the relevance of an object, and signifies an element of progressive thought by which we challenge what is the basic truth behind the reason for the product itself. Certain qualities of each product can be enhanced or subdued to give the desired effect.

Designers, engineer and infuse an object with perceptual and physical values that reach beyond pure functionality. Function is often posited with form, yet such a purist approach to design seems to be less popular than the idea of layering other value-generating product offerings that go beyond form and function. An emphasis on other aspects of the object can induce a novel product through greater attention to intangible qualities

The marriage of certain characteristics makes a product stand out and even suggests a less recognised use. Ambiguity and challenging the traditional norms of form and function are mainstays for today.

### ERGONOMICS

Ergonomics being the applied science concerned with designing and arranging products so that the end user and the product interact safely and in the most efficient way (Adler, 2006).

Design is not just about the application of technology, form and functionality; rather it is about people and understanding behaviour. Perhaps this is where we can locate the essence of designing the unexpected.







## MULTI FUNCTIONALITY

Multi functionality is demanded within the sustainable context of our everyday life. Static forms that once served a single purpose now provide dual or multi functionality. The simple way the end user can interact with the object is not confusing, but beneficial when the product reinforces its rightful presence within context.

Chameleon products either have a function that is out of sight when not in use, or change to move from one use to another, producing a more ambiguous affect. Still other products make a show of this added functionality.

## LIFE CYCLE AND SUSTAINABILITY

The life cycle of a product will be the various stages through which a product passes from introduction to the market to withdrawal or obsolescence (Hanaor, 2006). There are many considerations that relate to a product's life cycle. These include: growth and decline of market, changes in style and fashion, availability, reliability, systems for maintenance, opportunities for upgrades, and ecological considerations.

Slack reminds us (Slack 2006: 66) that a product with an ephemeral nature will have a short life cycle due to factors such as fashions, trends and technological obsolescence. Waste is a key; of product specific concern. There are two main types of waste: physical and perceptual. Perceptual waste is caused by cultural forces that determine value and desire; physical waste relates to tangible material waste – direct or indirect residues from a particular process and/ or use.

There are means by which we can improve life spans, and not only by using ecological materials. We can consider: redesigning within the areas of waste management; reuse; restorative waste cycles in which one man's waste is another man's fuel; ease of repair; durability; flexibility for choice; and add-on components with improved upgrades (Hanaor, 2006). We need to devise new methods of working and communicating beyond geo- and socio-political boundaries, to question material applications, and also take on the consequences of our imagination should the design fail in some way.

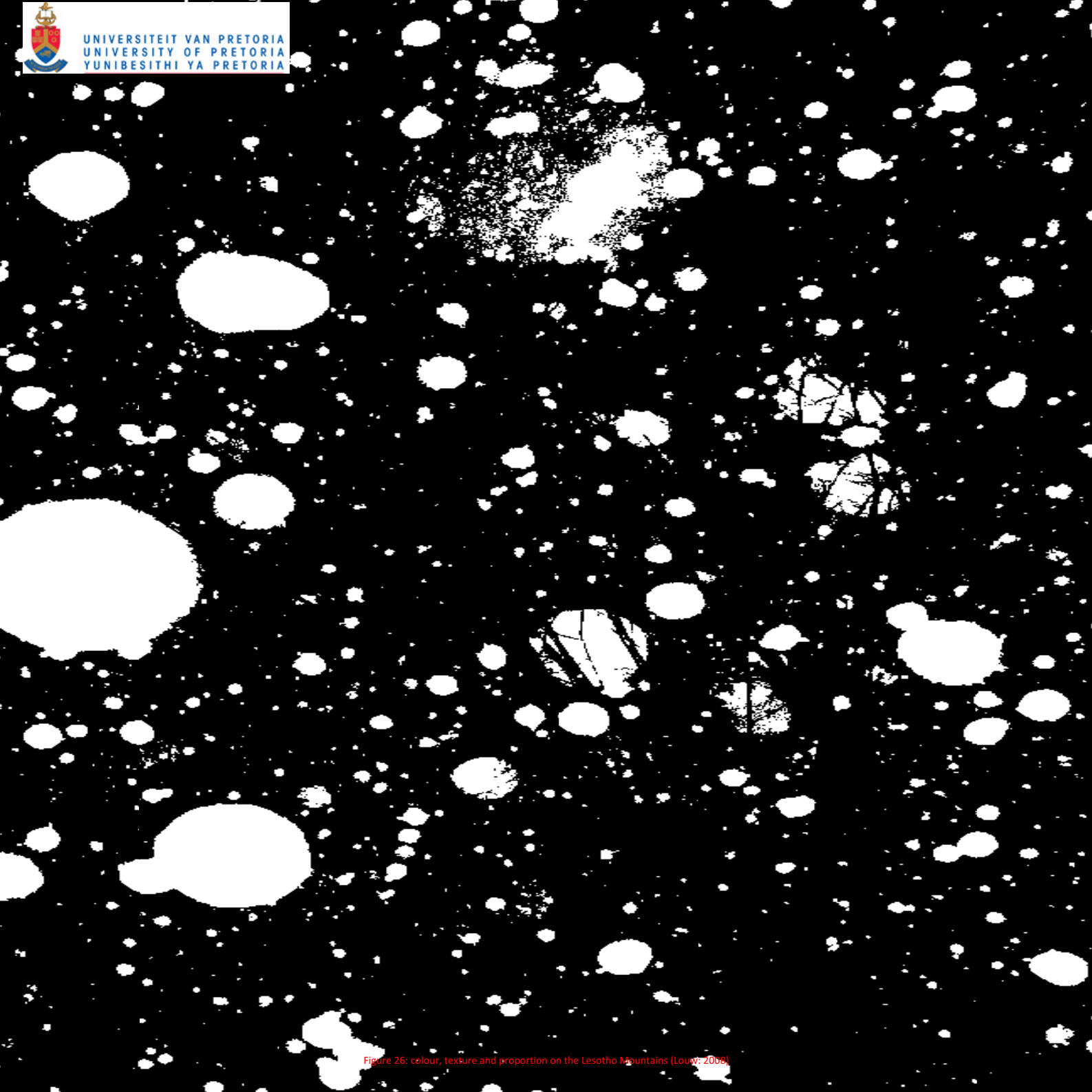

Figure 26: colour, texture and proportion on the Lesotho Mountains (Louw, 2008)



## COLOUR

>>

Colour is like visual poetry to the eye and should be considered thoroughly in product design. Colour has a psychological effect on our moods and behaviour; it affects how we respond to our surroundings. Colour is not purely a visual manifestation – it affects the mind on a subliminal level.

The selection of a colour depends on the relevance of the product in use and in the end user's context. Vivid colours create a strong impact that attract and draw attention. Colour can highlight and reinforce, or blur a detail of a product; it can unify and simplify the general form. Designers, for example, usually apply a monochrome approach to colour within their designs or use the naturally occurring colour of a material.

Product design needs to take on a greater understanding of both colour and both the tangible and intangible effects it has on the end user and their decisions (Slack, 2006). Colour is usually considered toward the end of the design process and is rarely the starting point. Colour is dependent on the end use of the project and the mind of the designer.

## TEXTURE

>>

A product's texture can provide a tactile experience or a visual play on its perceived tactility upon contact. The skin of the product is a human/ product interface where, practically, the internals are concealed and protected from everyday use, and, experientially, the user perceives sensory responsiveness (Lupton, 2002). There are many ways to induce an intended response through the selection and application of a multitude of materials, finishes, and processes to create the desired properties of the product "skin".

Texture can be given to a surface in many ways to add to the product experience: Printing, embossing, lacquering, painting, polishing, brushing, layering, adding textile structures and more variants.

In a visual and tactile sense, the play of a flattened or enhanced surface provides more information to the end user and can heighten or dampen the user's response to the objects hidden or accentuated attributes (Lupton, 2002). Texture can highlight overall or specific areas of functionality, shape, and decorative effect.

The application of different textures provides the user with information in order to assess and understand the placement of a product within their environment.

## PROPORTION

>>

The proportion of a product needs to be set in the mind of the observer as a specific object in the context of particular surroundings or other designs.

Designs with pleasing relationships between the parts of a whole and its surrounding, require a consideration not only of the actual object, but also of the relationship of the object to its environment.

Individuals interpret the placement of products within an environment in their own, personal way; the result can be intrigue or a sense of peace and beauty. A designer questions the recognised "truths" about proportion, and their application, through the design process.



**droop**  
LESOTHO  
**droop**





## BRANDING

>>

To brand a product is to place it in a new context, to make it familiar, to leave a mark in time, and add another dimension to the way it is viewed (Olins, 2008). Branding is an important element of the design process and demands consideration in a world in which it is increasingly hard to gain visibility.

According to Olins (2008) brand identities are created when visual, auditory and written messages are sent consistently. He also reminds us that a brand is what consumers remember about a product after being exposed to marketing stimuli.

A name can convey perceptual qualities: a Diamond Chair must be precious and should be treasured. Often a name relates to the main characteristics of a product's appearance or to a certain function it can offer.

The key consideration in branding a product is problems that might arise from direct translation and whether the name is inventive or evokes certain experiences or observations. To give a product a name is a difficult undertaking in a global setting, where linguistic diversity, translation issues, pronunciation, and meaning must all be considered. The name of an object should flow off the tongue and be pleasant to say in as many languages as possible.

Branding can be a powerful means of offering a direct visual image of a product or adding a layer of ambiguity, with an indirect or completely fictional interpretation of the product (Interiors Forum Scotland, 2007).

A good name is a powerful force in branding and can help differentiate or add emotional context to a product to engage your customer. If one can conjure a certain feeling in the user by emphasising the intangible qualities that indirectly reveal the product, one will have an edge on a less evocative competitor (MINE™, 2005).

Brand recognition and other reactions are created by the use of the product or service and through the influence of advertising, design, and media commentary. A brand is a symbolic embodiment of all the information connected to the product and serves to create associations and expectations around it and therefore very important in the success of the product (IFS, 2007).





## FACTORS TO CONSIDER

### 1. Alternative format

>

#### General considerations

An alternative format describes a different presentation or representation intended to make products and services accessible through a different modality or sensory ability. By providing all input and all output, i.e. information and functions, in at least one alternative format, for instance visual and tactile, more people, including some with language/literacy problems, may be helped.

>

#### Alternatives to visual information

The type and texture of surface finishes can be important in providing tactile feedback which can reinforce instructions and warnings for those with visual impairment. Where the principal form of instruction on a product or in a building is written, alternatives would be:

voice (instructions 'spoken' by a product or service)

sound (feedback from clicks, bells and buzzers) or

touch (tactile marking or grip).

Wherever feasible, visual information which is presented should be available in audio or other sensory stimuli for those with a visual impairment including those who cannot read Braille, as well as for those who have difficulty with reading or are unable to read. Printed visual information should be available in alternative formats (electronic audio, large raised letters or Braille, etc.) which are readable by individuals without vision and in large print for those with low vision.

>

#### Alternatives to auditory information

Wherever feasible, sound signals should be supported by visual or other sensory stimuli for those with a hearing impairment (e.g. communication in writing, graphical symbols, vibration or sign language). In particular, audible warnings, such as fire alarms, should also activate, for example, visual stimuli, such as flashing lights which are well sited and clearly indicated.

### 2. Location and layout of information and controls and positioning of handles

>

#### Location

The position of information and controls on a product, or in a building are important. They need to be prominent for someone with a visual impairment or language/literacy disability, visible from the angle of view of someone standing and seated in a wheelchair, and easily accessed by seated or standing users without bending and stretching.

>

#### Spaces

The design of spaces can incorporate simple measures that enable people to feel more confident in the physical environment, such as well-placed, sturdy handrails. Controls and door handles within easy reach facilitate use by those with impairment in dexterity, manipulation, movement or strength.

>

#### Layout

The layout of information and controls will also determine how easy they are to read by someone with a visual or cognitive impairment. Factors to consider include logical grouping of information and controls, line length of text, relevance of information and relationship of controls to actions to be undertaken.





оставете вратите да функционираат сами !!  
двери открываются и закрываются автоматически  
laisser les portes fonctionner seules !!  
do not try to open or close the doors !!  
bitte nicht die turen ziehen oder schieben !!



### SAFETY INSTRUCTIONS

DURING REGULAR OPERATION, IT IS FORBIDDEN:  
→ TO MOVE AROUND AND TO CAUSE THE GONDOLA TO SWING  
→ TO OPERATE THE DOOR OPENING DEVICES  
IN CASE OF A PROLONGED STOP, YOU MUST AWAIT THE INFORMATION  
WHICH WILL BE GIVEN BY THE OPERATING STAFF



### 3. Lighting levels and glare

>

#### Provision of lighting

Appropriate lighting ensures that those with a visual impairment are better able to see instructions and controls. This should also be considered for those with a hearing impairment to assist with lip reading or sign language communication. By default lights will always be on and should be switched off should it cause hindrance.

>

#### Spaces

Adjustability of lighting levels in a space is desirable to suit different needs but sudden changes in lighting levels should be avoided.

>

#### Avoidance of glare

Too high light levels and strong directional light can result in deep shadows or glare. Reflecting surfaces on information panels should be avoided, to reduce the possibility of glare.

### 4. Colour and contrast

>

#### Choice of colour

This is important for ease of recognition and ease of seeing. Some colour combinations are also more effective. Like black and white.

>

#### Colour combinations

The best colour combinations depend on the purpose of information, whether it is for guidance or a hazard warning, and the lighting conditions under which it is most likely to be viewed. For example, black on yellow or light grey are general purpose combinations which provide strong definition without too much glare, pastel shades on pastel backgrounds or red lettering or symbols on light grey are difficult to see and should normally be avoided.

>

#### Colour coding of information

All information conveyed with colour should also be available without the perception of colour. Colour coding should not be used as the only means of conveying information, indicating a response or distinguishing a visual element.





#### 5. Size and style of font and symbols in information, warnings and labeling of controls

>

The required size of font for information, warnings and labeling of controls, relates to the probable viewing distance, level of illumination and colour contrast of the text against its background. The choice of font, whether with or without serif, in upright form or italics and light, medium or bold appearance also has a significant impact on legibility. Standards developers should also be aware that text written in CAPITAL letters is more difficult to read.

This is significant for those with a visual impairment. Consideration should be given to specifying size and style of font and symbols for warnings.

#### 6. Clear language in written or spoken information

>

Information available as text

Information should be made available in text format wherever possible, in addition to other forms, to facilitate recognition and translation into speech and other languages for those who have trouble seeing, recognizing or deciphering non-text information presentations.

>

Pictographs/pictograms

Pictography is a form of writing in which ideas are transmitted through drawing.

Pictograms can often transcend languages in that they can communicate to speakers of a number of tongues and language families equally effectively, even if the languages are cultures are completely different. This is why road signs and similar pictographic material is often applied as a global standard, expected to be understood by nearly all.

>

Complexity of information

Instructions or operations which are too complex will often deter older persons and persons with limited intellect from using a product or device. Simple written or spoken messages are also clearer to understand by someone with a visual or hearing impairment. All safety instructions in the funitel should thus be kept direct and simple.

>

Spoken information

The context should always be given to ensure that information is meaningful and instructions should be provided in a logical order. Key points should be reinforced by repetition. People with hearing loss are at an increased risk or disadvantage if spoken announcements are not loud enough, or if the pitch is too high or too low. All this should be taken into account when voice recordings are played in the enclosed funitel.

>

Multiple languages

Where instructions are to be provided in more than one language, written information in each language should be presented in separate sections of a manual rather than interleaved on a page; spoken information should be preceded by a clear statement in the language to be used.





#### 7. Graphical symbols and illustrations

>

The use of meaningful graphical symbols or illustrations, in addition to text, should be considered in instructions and also on a product, for ease of assembly or use. For example the same symbol should be used on the respective ends of parts to be joined, when assembling a product, or in the labels on controls.

#### 8. Loudness and pitch of non-spoken communication

>

People with a hearing loss are at increased risk or are disadvantaged if warnings are not loud enough, or if the pitch is too high or too low. Where possible, volume should be adjustable over a wide range. Information should also be presented in multiple frequencies where possible (e.g. an alarm signal could consist of a strong component at multiple frequencies). Sudden changes in volume should also be avoided.

#### 9. Slow pace of information presentation

>

Announcements spoken at a slow measured pace allow listeners to pick out the message; pauses between instructions give time to understand and act on the information. Consideration should be given to the length of time information remains in view when presented on moving displays, or when information is temporarily displayed and then removed.

#### 10. Distinctive form of objects

>

##### Identification by form

A distinctive form can make it easier for those with visual impairment and reduced touch sensitivity to identify an object, to interpret the parts of a product to be joined during assembly and to distinguish between different controls. A familiar form can also aid those with impaired cognitive ability, such as identification of seating and the control panel in the funitel.

>

##### Orientation of objects

Where possible, the form of the object or control should also indicate the orientation of the product or control, so the top or bottom, front or back, can be easily located by someone with a visual impairment.

#### 11. Controls

>

##### Handling

The force required to twist, turn, push or pull controls or fastenings is significant for people with various impairments. Operating controls should allow comfortable grip, avoid twisting of the wrist, avoid the need for simultaneous actions and offer minimal resistance. Textured surfaces, to increase friction, assist the application of force. Provision of alternative controls offering greater leverage or power-assistance should be considered. Preprogrammable operation and personal preferred settings can be effective, particularly for people with cognitive impairment.

>

##### Spacing

Controls should be spaced to avoid interference when another one is being operated.

>

##### Timed responses

Whenever possible, users should be able to control any limits on the amount of time available to them to read or respond.

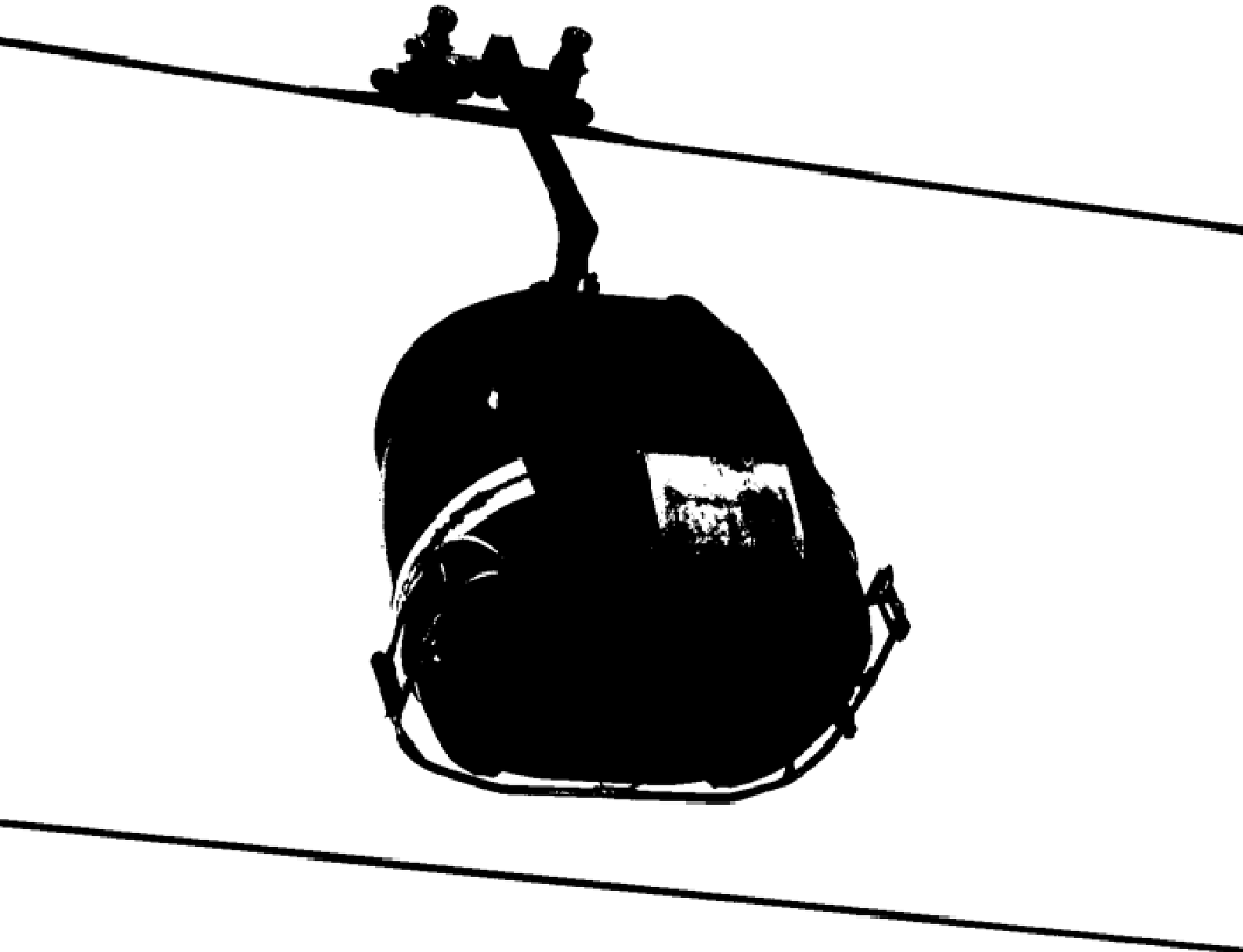

Figure 32: gondola in Bulgaria (Louw: 2005)



## 12. Accessible routes

>

### Flooring

Flooring should be reasonably slip-resistant, firm and stable. Floor guidance for visually impaired people should be provided.

>

### Swing, sliding or powered door-closing systems

Automatic opening door systems in emergency situations controlled manually. These can injure people and should incorporate appropriate safety mechanisms. Consider alternative audio indication on opening and closing of funitel door.

>

### Seating

This should be provided at appropriate locations in a facility or environment to enable users to rest.

>

### Coverage

Accessibility should be planned for all areas where people normally work or use the environment; it should be ensured that the accessible routes connect those areas by the shortest possible path. Care should be given to the inclusion of sanitary facilities within the accessible routes.

>

### Route information

Guidance on accessible routes through a building is of particular value to those with a visual, movement or cognitive impairment.

## 13. Surface finish

>

### Slip-resistance and texture

The surface finish of any space is important for all people. A non-slippery surface aids gripping and manipulating.

## 14. Non-allergenic/toxic materials

>

Avoidance of toxic and allergenic materials is particularly important for people with impaired tasting or smelling ability and those with contact, food or respiratory allergies. Examples of everyday objects that contain nickel or chromium, which can create an allergic response, include doorknobs and window frames. People with visual impairment who rely on touch or tactile feel may be at risk if they come into contact with allergenic materials.

## 15. Fire safety of materials

>

Consideration should be given to the fire-resistance qualities in products and buildings used by people with disabilities. Materials susceptible to ignition by a small source such as a cigarette, match or other small flame present a potential hazard if they continue to burn, producing toxic smoke or result in rapid growth of fire. People who





Figure 33: mountain activities and detachable chairlifts (Louw: 2005)





Figure 34: Cobblestone pavement texture (Low: 2007)

## MATERIALS

The selection of materials for a given project is influenced by physical properties relating to durability, sustainability and shape forming – the study of which is based in specialist areas of ergonomics – and is important to the aesthetic characteristics prescribed by the designer and end user.

Interesting material applications offer great shapes and tactile reference (inclusive design). Material selection is also key to creating mystery and ambiguity. It is not new materials that can offer a route to design innovation: traditional processes, crafted techniques, or old (even recycled) materials can be imbued with new life through previously unrelated applications.

### ARBOFORM

Referred to as “liquid wood” (<http://www.ecolect.net/materials/view/arboform>), Arboform is a high-quality thermoplastic engineered material for applications that demand high technological standards. It combines the positive properties of natural wood with the processing capabilities of thermoplastic materials.

>

Uses:

Like any synthetic thermoplastic material, Arboform can be formed into mouldings, plates or slabs using traditional plastics’ processing methods and machines. Cases for computers, televisions or cell phones can be made from this new “wood” material. By mixing lignin with natural fibres (flax, hemp or other fibre plants) and some natural additives, a fibre composite is produced. This composite can be processed and formed at raised temperatures to create parts.

>

Manufacturing:

The raw material used to make these thermoplastic granules is lignin. Lignin is the most abundant natural polymer (the first is cellulose). Lignin is a by-product of the pulp industry. Worldwide, nearly 50 million tons of lignin is produced annually.

Arboform can be processed in an injection-moulding machine like any normal thermoplastic, and used to manufacture aesthetically pleasing products such as nativity figures, loudspeaker units, car instrument panels, chessmen for board games, or the stock of hunting rifles (<http://www.technaro.de>).

>

Technical specifications

The disposal of Arboform is the same as naturally grown wood.

### HUSQUE

Husque is a unique composite material comprising mostly of waste Australian Macadamia Nut Shell. The husque material can be machined, moulded, polished and combined with colour as with the image attached.

The Husque company was formed in 2003 by product designer Marc Harrison and architect Paul Fairweather to develop the Husque material and to apply it in the manufacture of designer and architectural products. Marc created this unique material of Australian macadamia shell milled and processed with a polymer to create a dense mouldable material.

Husque combines the iconic Australian macadamia nut, the principles of recycling and the ingenuity of Australian design to create elegant design objects. The range includes bowls, a tray and a vase each available in many colours (<http://www.husque.com/>)



## PMMA (POLYMETHYLMETHACRYLATE)

Acrylic plastic refers to a family of synthetic, or man-made, plastic materials containing one or more derivatives of acrylic acid. The most common acrylic plastic is polymethyl methacrylate (PMMA). Also known as Lucite, Oroglas, Perspex and Plexiglas which vary according to the country you are in. The original PMMA was seen as a replacement for glass in a variety of applications and is currently used extensively in glazing applications. The material is one of the hardest polymers, rigid, glass-clear with glossy finish and good weather resistance. PMMA is a tough, highly transparent material with excellent resistance to ultraviolet radiation and weathering. It can be coloured, moulded, cut, drilled, and formed. It is also non-toxic and recyclable. These properties make it ideal for many applications including airplane windshields, skylights, automobile taillights, and outdoor signs. (Ashby, Johnson 2002: 193.)

>

Physical properties:

PMMA is a glassy polymer with an amorphous structure. It has a density of  $1.19 \text{ g/cm}^3$  and has very low water absorption. The refractive index ranges from 1.49 to 1.51 depending on the type. (Ashby, Johnson 2002: 193.)

>

Mechanical properties:

Parts made of PMMA have high mechanical strength and good dimensional stability. Other properties include a high Young's modulus and good hardness with low elongation at break. PMMA does not shatter on rupture. PMMA is one of the hardest thermoplastics and is also highly scratch resistant. (Ashby, Johnson 2002: 193.)

>

Thermal properties:

The thermal stability of standard PMMA is only  $65^\circ\text{C}$ . Heat-stabilised types can withstand temperatures of up to  $100^\circ\text{C}$ . PMMA can withstand temperatures as low as  $-70^\circ\text{C}$ . Resistance to temperature changes is very good (Ashby, Johnson 2002: 193).

>

Optical properties:

PMMA is naturally transparent and colourless. The transmission for visible light is 92%. The refractive index is 1.492 for PMMA. There are types that transmit UV rays, and types that absorb it almost completely, as a result of which sensitive dyes on painted surfaces behind are protected from fading.

>

Natural colour:

PMMA is crystal clear and has a high surface gloss. It can be produced in all colours, transparent and muted.

>

Advantages (Ashby, Johnson 2002: 193):

Material is very hard.

Material is clear and can be coloured in any colour from opaque to translucent.

Good weathering resistance.

Good optical properties.

High gloss.

Scratch resistant (but not as good as glass because it does scratch).

Variations of shatterproof are available.

>

Limitations (Ashby, Johnson 2002: 193):

Difficult to mould thin walled products because of poor flow properties.



Figure 36: German Tiger Helicopter Equipped PMMA protective glazing (Moore: 2007)

>

#### Manufacturing:

Reacting a monomer, such as methyl methacrylate, with a catalyst, forms acrylic plastic polymers. A typical catalyst would be an organic peroxide. The catalyst starts the reaction and enters into it to keep it going, but does not become part of the resulting polymer.

Acrylic plastics are available in three forms: flat sheets, elongated shapes (rods and tubes), and moulding powder. Moulding powders are sometimes made by a process known as suspension polymerization in which the reaction takes place between tiny droplets of the monomer suspended in a solution of water and catalyst. This results in grains of polymer with tightly controlled molecular weight suitable for moulding or extrusion. (Ashby, Johnson 2002: 240.)

Ashby explains that the (Ashby, Johnson 2002: 241) acrylic plastic sheets are formed by a process known as bulk polymerization. In this process, the monomer and catalyst are poured into a mould where the reaction takes place. Two methods of bulk polymerization may be used: batch cell or continuous. Batch cell is the most common because it is simple and is easily adapted for making acrylic sheets in thicknesses from 0.06 to 6.0 inches (0.16-15 cm) and widths from 3 feet (0.9 m) up to several hundred feet. The batch cell method may also be used to form rods and tubes. The continuous method is quicker and involves less labour. It is used to make sheets of thinner thicknesses and smaller widths than those produced by the batch cell method.

>

#### Injection moulding:

Pre-drying is not necessary if a vented cylinder is used but if a normal cylinder is used then PMMA must be processed dry and it is advisable to pre-dry the granules for up to 8 hours at 70 to 100°C, depending on the type. Surface defects and blisters will form if damp granules are processed. Processing parameters: The mould temperature should be between 40 and 80°C, depending on the type. The material temperature should be between 200 and 250°C. As the temperature rises, molecular orientation and internal stresses decrease, but the risk of sink spots increases. As a general rule, high injection pressures are needed because of poor flow properties and it may be necessary to inject slowly to get the correct flow. This is particularly important for optical mouldings where visible weld lines will form if the correct parameters are not used. For thick mouldings a high follow-up pressure is needed for a long time (2 to 3 minutes).

Large gates are needed because of the poor flow but hot runners are possible. Reprocessing is possible if the material has been thoroughly dried and has an opaque colour. Optically good mouldings are not generally possible with regrind even if the regrind is glass clear.

Shrinkage is relatively low: 0.4 to 0.8% depending on the grade used. Avoid wall thicknesses of less than 1 mm (Ashby, Johnson 2002: 193).

>

#### Extrusion:

Extrusion temperatures are between 180 and 250°C. Metering type screws with a compression ratio of 3:1 are generally recommended. Relatively high molecular weight formulations are used for the extrusion of sheets and profiles. A degassing screw with an L/D ratio of 20 to 30 is best.

>

#### Bonding:

Solvents can cause stress cracks if internal stresses are present in the moulded part, so it is advisable to temper the part at 60 to 90°C before bonding. Methylene chloride, polymerisation, epoxy resin, contact and impact adhesives are suitable. Adhesion with solvent-based and polymerisation adhesives is better than with contact adhesives (Ashby, Johnson 2002).



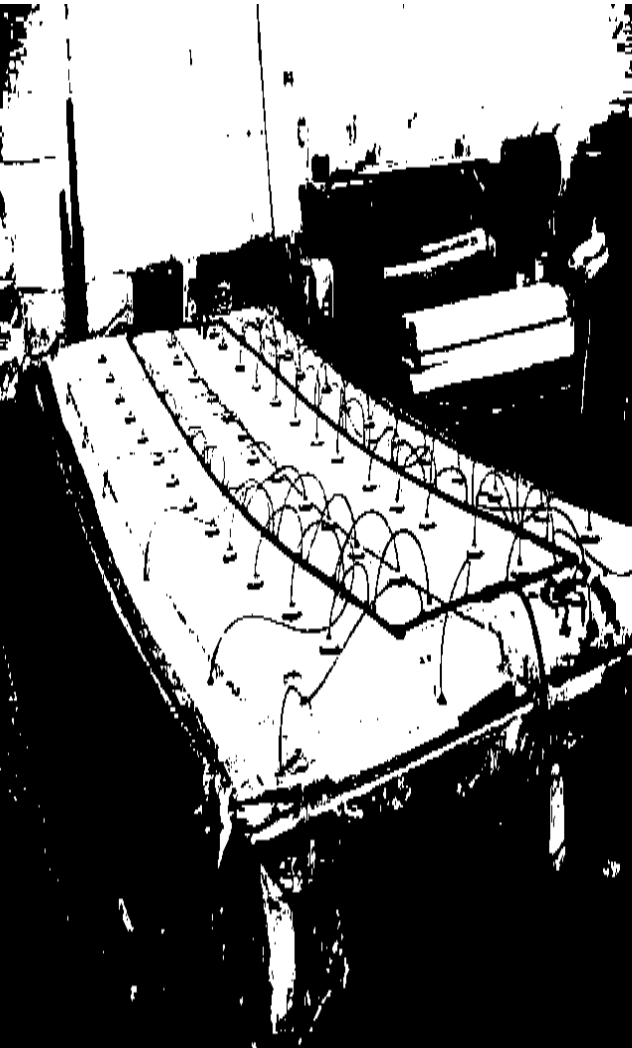

## GRP

Selected information in verbatim summarised from source (Moore, H., 2007. Composite Materials [information Sheet] (Personal communication, August 2007)

GRP stands for Glass Reinforced Polyester, outside the industry it is commonly referred to as fibreglass. Sheets of glass fibre matting are layered over a mould which is then coated with a special resin. The mixture is then left to set naturally or for quicker results is placed in an oven. The hardened polymer is then decorated and polished according to the customer's specified finish.

>

Physical properties:

Glass Reinforced Plastic (GRP) is a light, durable and astonishingly tough constructional material which can be fabricated into all manner of products. It may be translucent, opaque or coloured, flat or shaped, thin or thick. GRP is a composite of a resilient durable resin with an immensely strong fibrous glass. The resin is the main component and is normally a polyester resin. Just as concrete may be reinforced with steel rods, so polyester resins may be reinforced with glass fibres to form GRP. This is the fabrication process, a single surface mould on which is impregnated layers of glass mat with liquid resin until the required thickness has been built up and the laminate is then extracted from the mould. Glass fibre is one of the strongest of all materials (Table 1). The ultimate tensile strength of a freshly drawn single glass filament (diameter 9-15 microns) is about 3.5 GPa. It is made from readily available materials, it is non-combustible and chemically resistant.

>>

MATERIALS	GLASS CONTENT		SPECIFIC GRAVITY	TENSILE STRENGTH	TENSILE MODULUS	SPECIFIC STRENGTH
				MPa	MPa	MPa
Polyester / glass roving	54	70	1.9	800*	30*	400*
Polyester / glass cloth	38	55	1.7	300	15	200
Polyester / glass mat	18	30	1.4	100	7	70
Mild steel (structural)			7.8	310	200	40
Duralumin			2.8	450	70	150
Douglas fir			0.5	75	13	150
Hickory			0.8	150	15	200
Portland cement			4	10	17	5

Table 2: material strength of GRP compared steel and cement (Composite Materials information sheet 2007)

>

Mechanical properties:

A specific resistance, 2 to 4 times higher traditional materials, allows significant weight saving. According to applications, a GRP solution (i.e.: 70% fibres, 30 % resin) allows a weight save, for equal resistance, up to:

- 60 % in comparison to stainless steel,
- 65 % in comparison to aluminium, -
- 75 % in comparison to hot dip galvanised steel.

## SUMMARY

High degree of design flexibility. The practical uses of GRP are virtually endless, limited only by your imagination. GRP opened many new avenues for creative designers. Its unique physical properties allow it to be easily tooled, moulded and manufactured to meet almost any specifications. Because there are few constraints on size, shape, colour or finish, the styling and appearance can take precedence.

The lightweight strength of GRP has always made it a popular choice for manufacturing. Gram for gram GRP can be stronger than steel and sheet metals. Highly resistant to environmental extremes. Glass reinforced plastic products provide better performance than plain non-reinforced plastic units. GRP offers distinct advantages in a wide range of products; its reduced weight and maintenance make it attractive on architectural projects. More and more industries are discovering the benefits of its versatility.



Figure 38: manufactured GRP component by MMS Technologies (Moore: 2007)

>

*Thermal / Electrical properties:*

Excellent thermal insulation (1 000 times less heat conductor than aluminium),

Excellent electrical insulation (~ 6 KV / mm).

>

*Acoustic properties:*

GRP provides superior acoustical properties when compared to plastic or metal. Various type of sound deadening materials can be laminated between high strength layers of GRP mat to achieve the preferred level of sound deadening.

Stability: GRP exhibits the least amount of expansion and/ or contraction when compared to plastic, wood, or metals. GRP parts have excellent dimensional stability and will hold their shapes under severe mechanical and environmental stresses.

>

*Aesthetic properties:*

GRP parts are gel-coated in their moulds with a choice of flat, semi-gloss or high gloss colour eliminating the need for painting. In highly corrosive environments gel-coats are much more durable than most paints. GRP products can be manufactured in numerous finishes, textures and colours. GRP parts have sleek contours and a superior moulded appearance with high visibility colours.

>

*Other properties:*

GRP is non-corrosive and has a much longer life expectancy when compared to a variety of construction materials. In highly corrosive environments GRP is the preferred choice over metal, wood, or plastic. A popular choice where exposure to harsh environments is a concern, GRP provides resistance to ultra violet light, extreme temperatures, salt air, and a variety of chemicals including most acids. Because fibreglass is chemically inert and corrosion-resistant, it offers an economical alternative to stainless steel.

>

*Advantages:*

- The mould side of the product is left with a smooth aesthetically pleasing gelcoat finish, which never needs painting.
- GRP is cost effective in the long term, because it is corrosion resistant and maintenance free.
- Tooling costs are very low, in comparison with injection moulding and deep-draw steel tooling.
- Damaged products are repairable.
- GRP products have good chemical resistance.
- GRP products have good heat insulation.
- Mass production press tooling costs are very competitive compared to other options.
- GRP is versatile.
- GRP parts require very little maintenance - no rust, no painting, no wood rot. Reduces costly maintenance associated with repairing or replacing units.
- GRP is non-conductive, RF transparent, and helps to insulate against electromagnetic fields.

> **The GRP advantages in comparison to galvanised steel:**

- Corrosion resistance is not related to the zinc coating quality as on the steel.
- No risk of injury.
- Resistant to salt water, to sulphur, chlorine or basic environments.

> **The GRP advantages in comparison to aluminium:**

- No electrolytic corrosion due to contact of two metals in humid environment.
- Much higher life span in basic, chlorine or halogen atmosphere.

> **The GRP advantages in comparison to stainless steel:**

- Absence of corrosion under tension (mechanical).
- Absence of hollow corrosion.
- Recommended in chlorine.

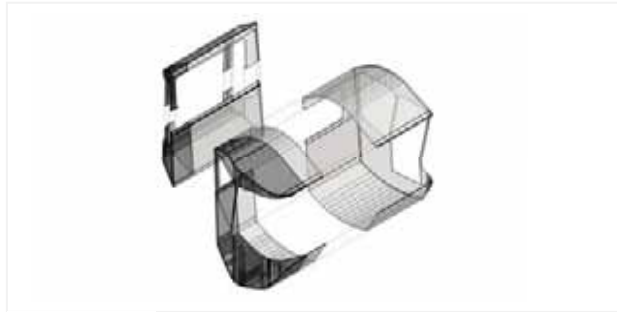

STEP 1 >>

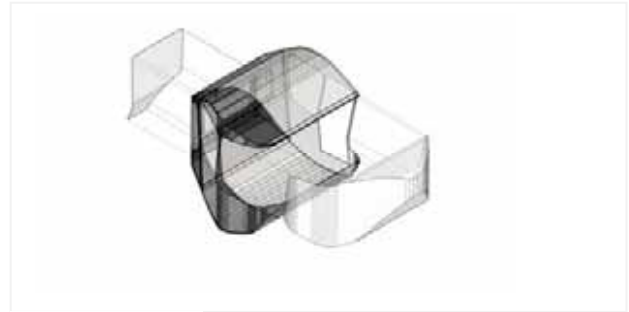

STEP 4 >>



STEP 2 >>

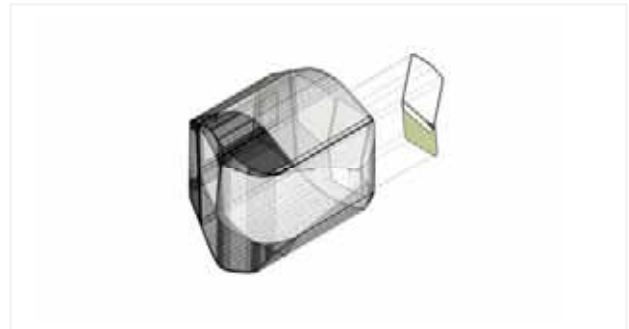

STEP 5 >>



STEP 3 >>



STEP 6 >>

>>

#### VEHICLE ASSEMBLY AND FASTENING

>

The vehicle will comprise of three major components:

- > 01 A left frontal lobe
- > 02 A right frontal lobe
- > 03 And a posterior lobe (

The left and right lobes will be joined by top and bottom structural components made out of CRP (carbon reinforced plastic) and pop riveted to the major components. A urethane seal will be responsible for a tight and secure grip between the components and assure that there will be no future leakage at the various joints. These structural components and joints will be covered by removable ceiling and floor systems which will also be riveted to these structural components as well as to the outer GRP skin of the vehicle.. These extruded profiles will thus perform dual functions as mentioned and are critical in the assembly of the vehicle as a whole (similar strength and function as known I-beams).

The posterior lobe will then be joined to the assembled frontal lobe. The posterior lobe (storage compartment) will further strengthen the whole assembly in that it will retain the two frontal lobes.

The windows are made from PMMA with UV-filters. All the PMMA glazing will be fixed to the GRP skin of the vehicle by means of a poly-urethane sealant and seals attached to GRP skin. The back window will be hinged at the top (similar to the mechanism used for Jeep Cherokee canopies) and will have a hydraulic mechanism which will assist in the opening and closing of the back window. The door opening/closing mechanism should be inserted in a compact, removable box and combines the door closing and locking functions.

#### INTERIOR COMPONENT ASSEMBLY AND FASTENING

>

##### STANDING (STANDARD) UNIT

- control box is fixed to the skin of the vehicle with self tapered screws (all electrical wiring for LED display etc. are hidden inside the control box and can easily be reached by unscrewing and removing the inside panel (see drawing)
- the waste bin is not be fixed but is removable
- the sound unit are also fixed to the skin of the vehicle, but easy to disassemble should it be repaired
- a ski holder are slide into a fixed u-component on outer GRP-skin of the cable car
- an all-purpose bicycle rack consist of two legs that are bolted onto a fixed mechanism on outer GRP-skin of the cable car

##### SEATER UNIT

- the seating unit consists of a bottom component which clip into the control box and its support, the back component alternatively slide into a fixed u-component (screwed into GRP skin).there are also a slide-in additional support for the bottom seating component as well as a slide-in footrest.

##### PIC-NIC UNIT

- The “pic-nic” unit are also clipped (some mechanism as seating component) into the other clip permanently attached to the anterior skin of the vehicle. The control box provides support for the entire one side of the unit. The unit can be finger hinged “up and down” so that passengers can sit down as they enter the vehicle.

The entire detachable component range makes use of a specific designed clip-in, slide-in and bolted mechanisms which makes assembly and disassembly of the components effective and easy. All mechanisms are fixed which minimise loss and theft of these mechanisms usually needed in assembly. By designing compact units one makes adds comfort to storage and transportation components.



Figure 49: Mountains and an aerial transport system (Louw:2005)





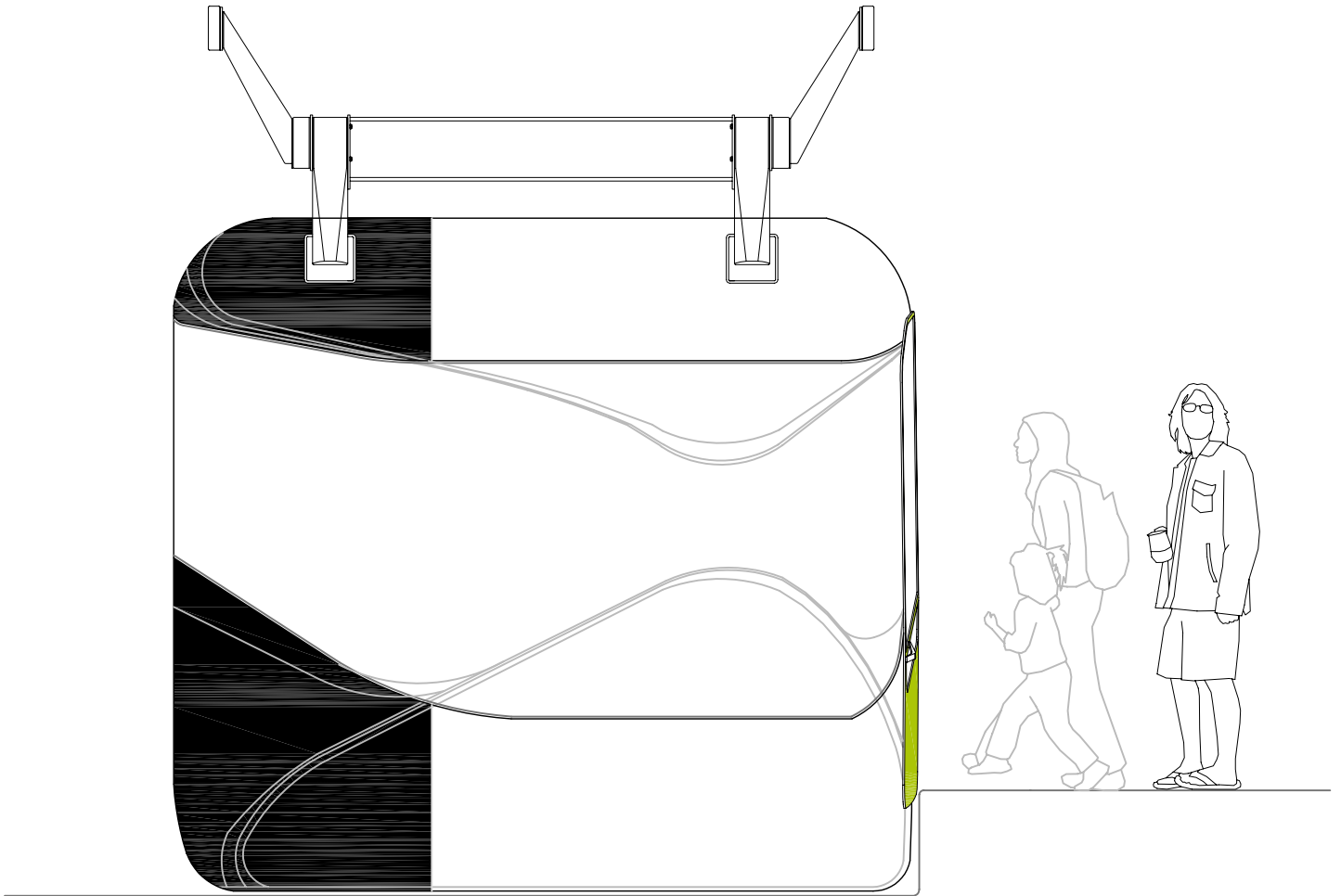

FRONT ELEVATION  
SCALE 1:30

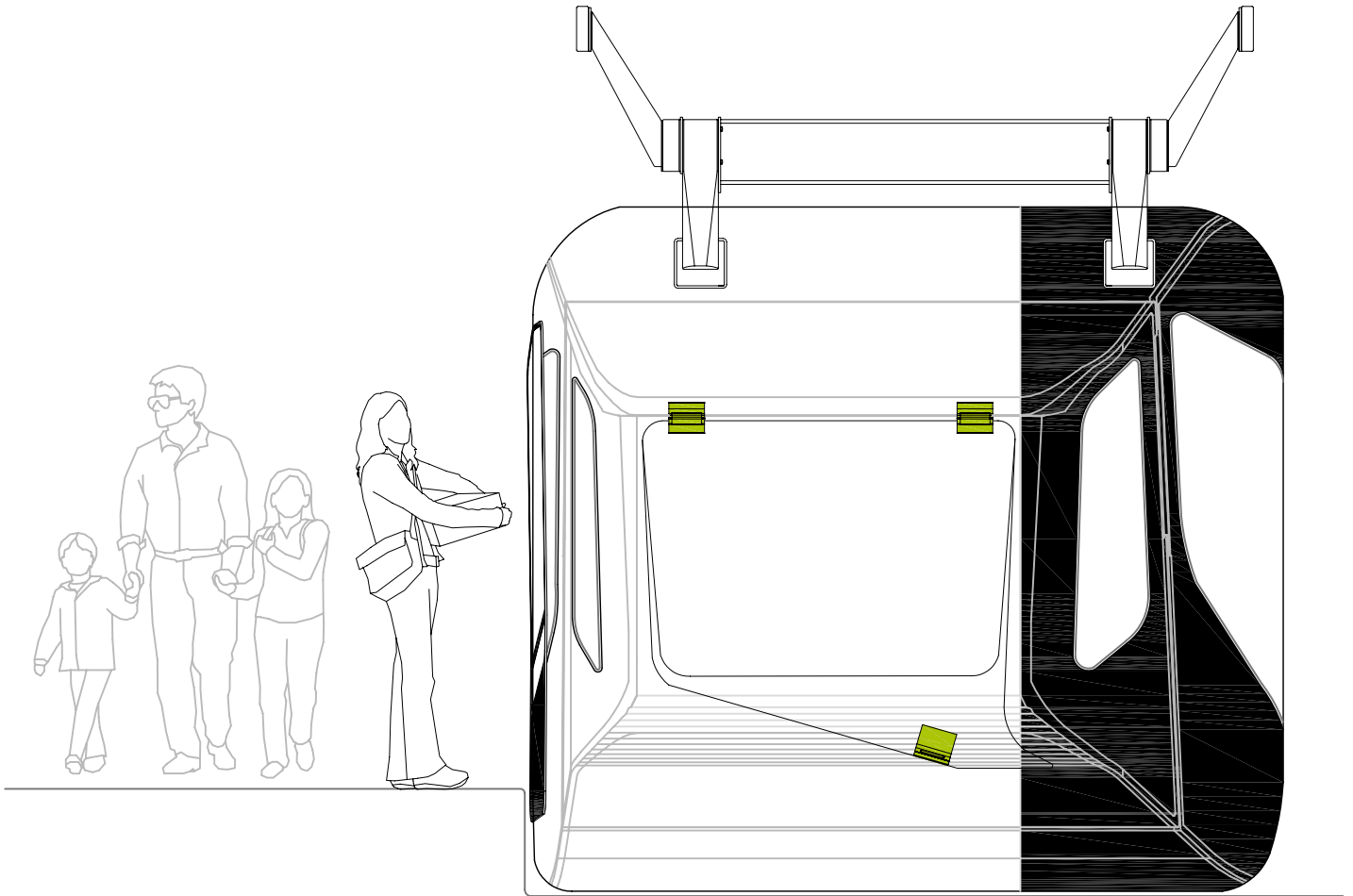

BACK ELEVATION  
SCALE 1:30



UNIVERSITEIT VAN PRETORIA  
UNIVERSITY OF PRETORIA  
YUNIBESITHI YA PRETORIA

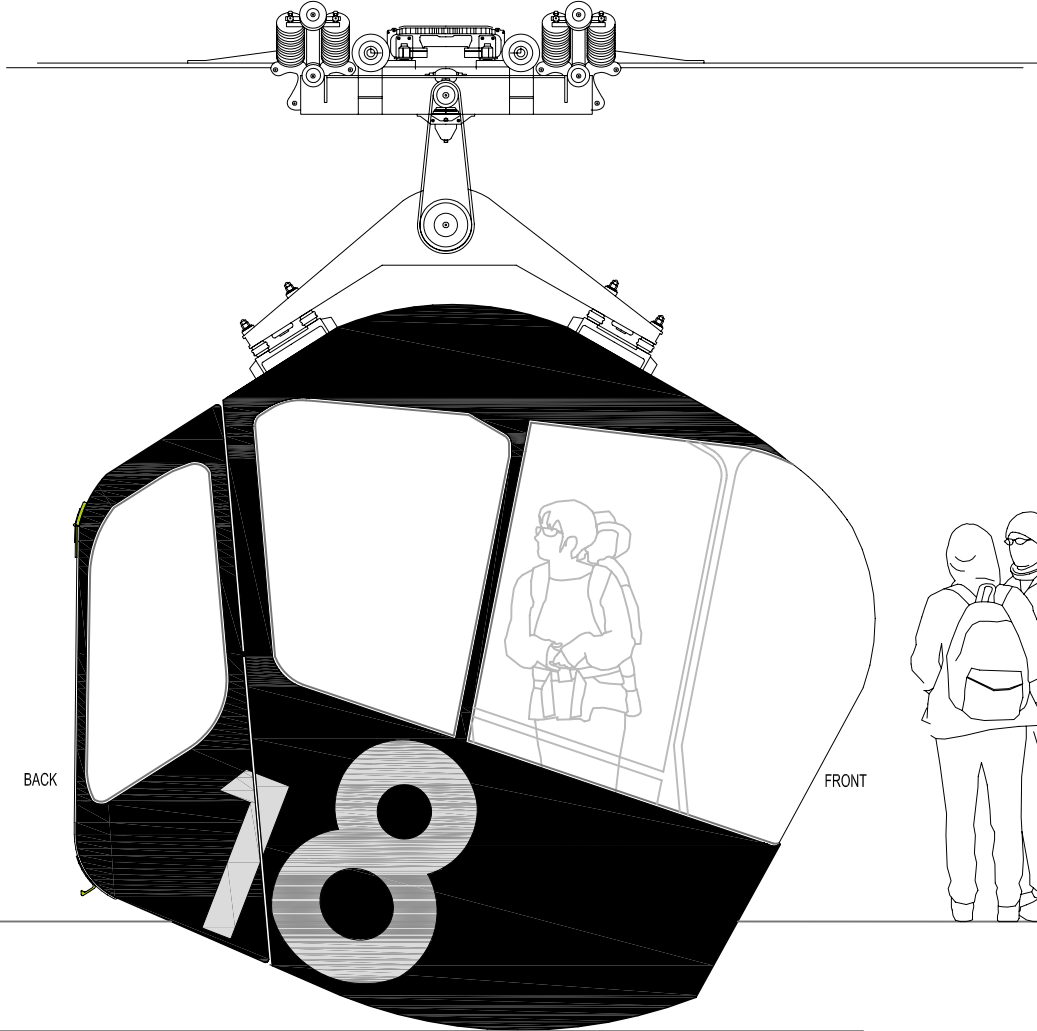

LEFT ELEVATION  
SCALE 1:30

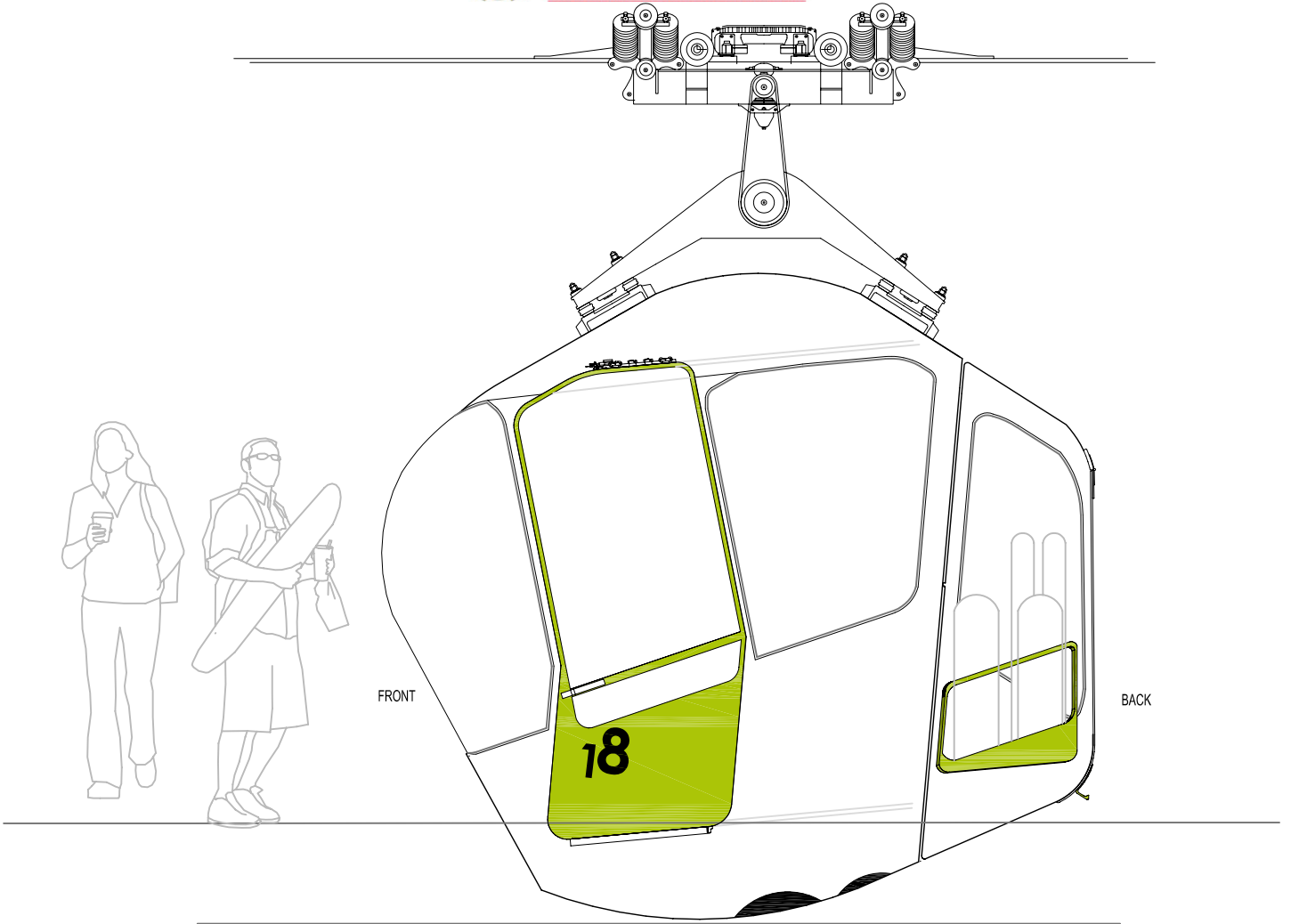

RIGHT ELEVATION

SCALE 1:30

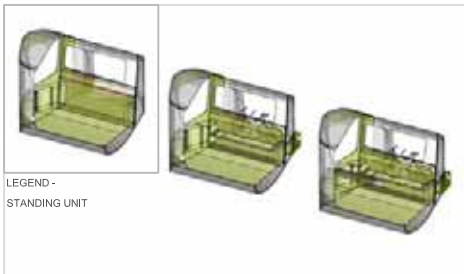
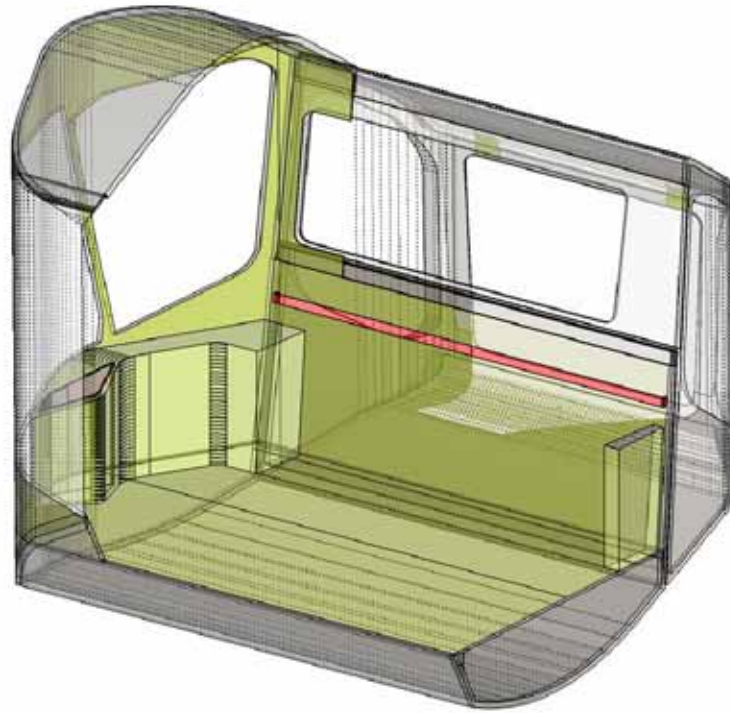

STANDING UNIT A (10 + 1 commuters)  
NO SCALE

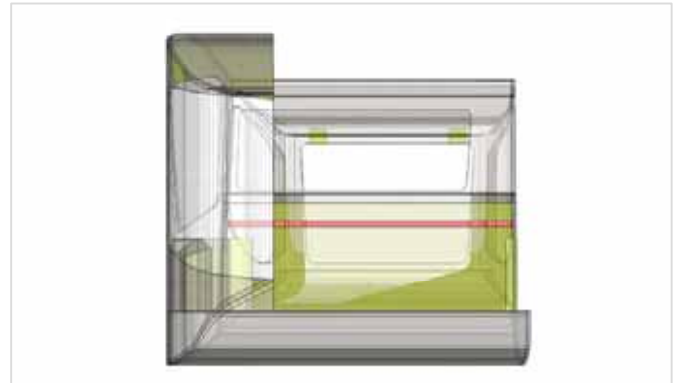

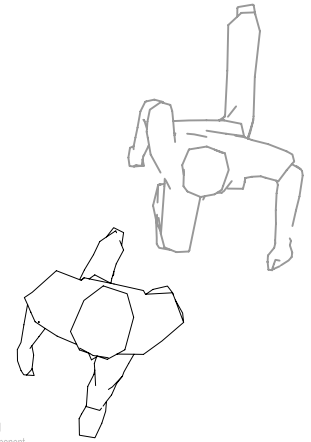
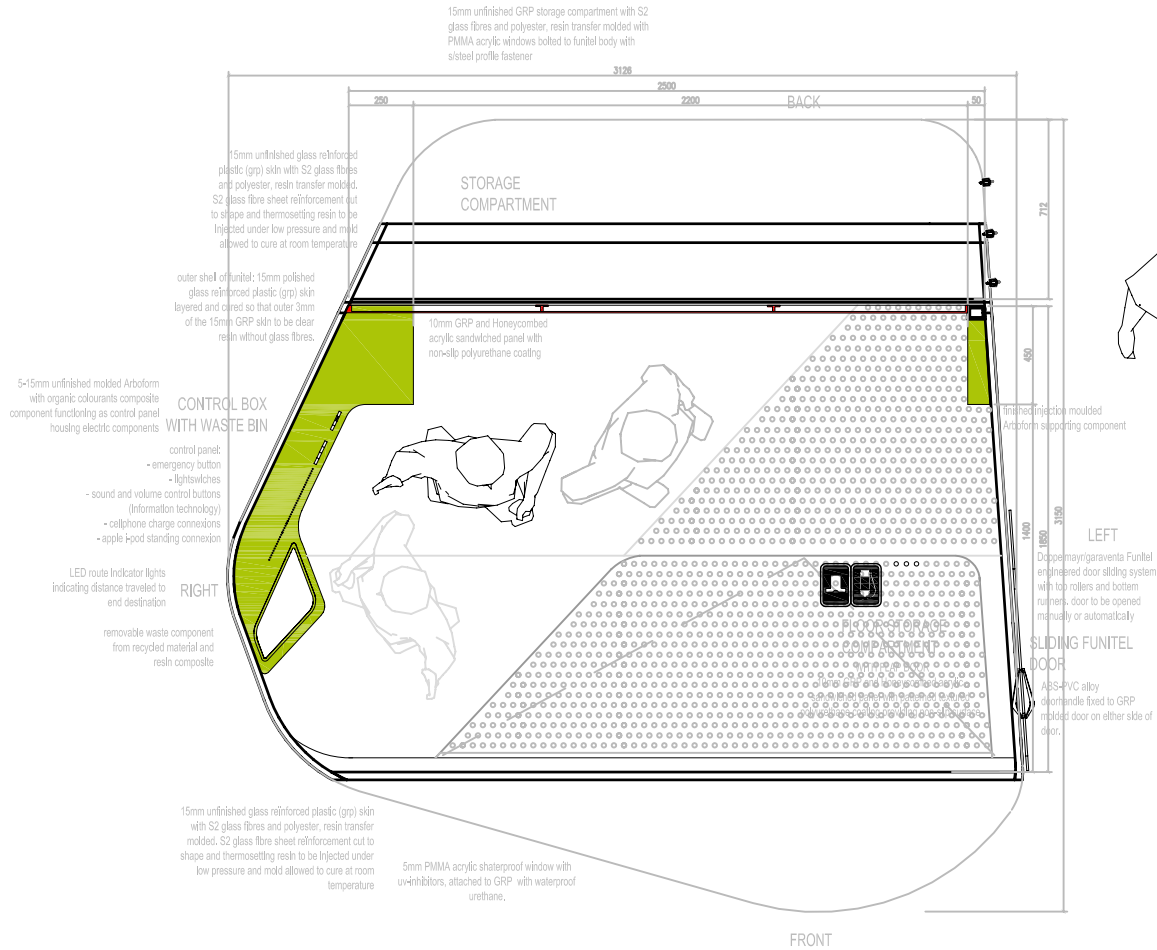

PLAN - STANDING UNIT A (10 + 1 commuters)  
SCALE 1:30

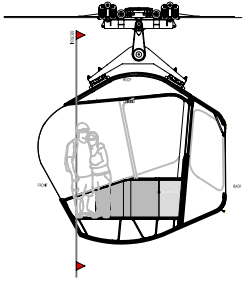

SECTION INDICATOR

20mm unfinished glass reinforced plastic (grp) skin with S2 glass fibres and polyester, resin transfer moulded. S2 glass fibre sheet reinforcement cut to shape and thermosetting resin to be injected under low pressure and mold allowed to cure at room temperature. GRP skin layed and cured so that outer 3mm of the 20mm GRP skin to be clear resin without glass fibres.

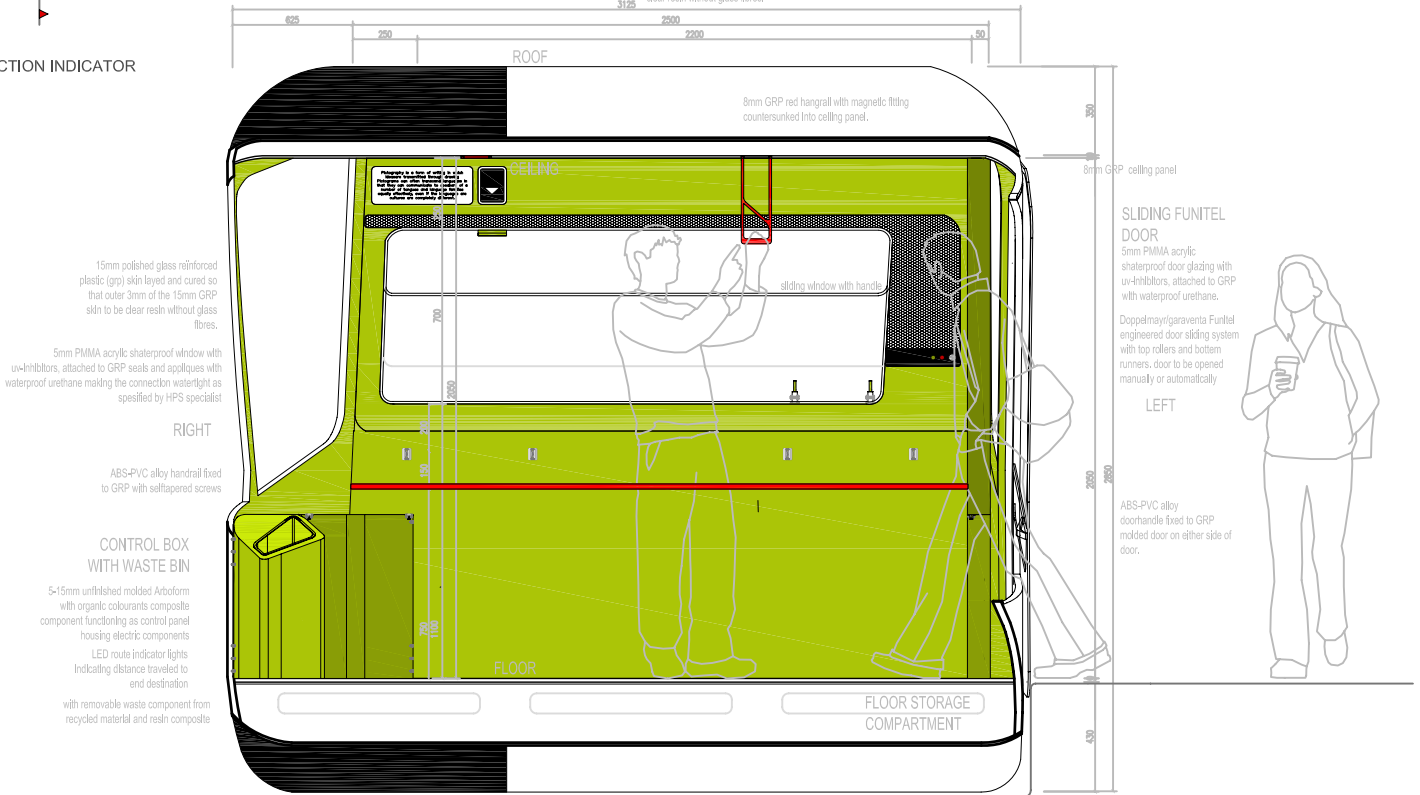

20mm unfinished glass reinforced plastic (grp) skin with S2 glass fibres and polyester, resin transfer moulded. S2 glass fibre sheet reinforcement cut to shape and thermosetting resin to be injected under low pressure and mold allowed to cure at room temperature. GRP skin layed and cured so that outer 3mm of the 20mm GRP skin to be clear resin without glass fibres.

SECTION - STANDING UNIT A (10 + 1 commuters)  
SCALE 1:30

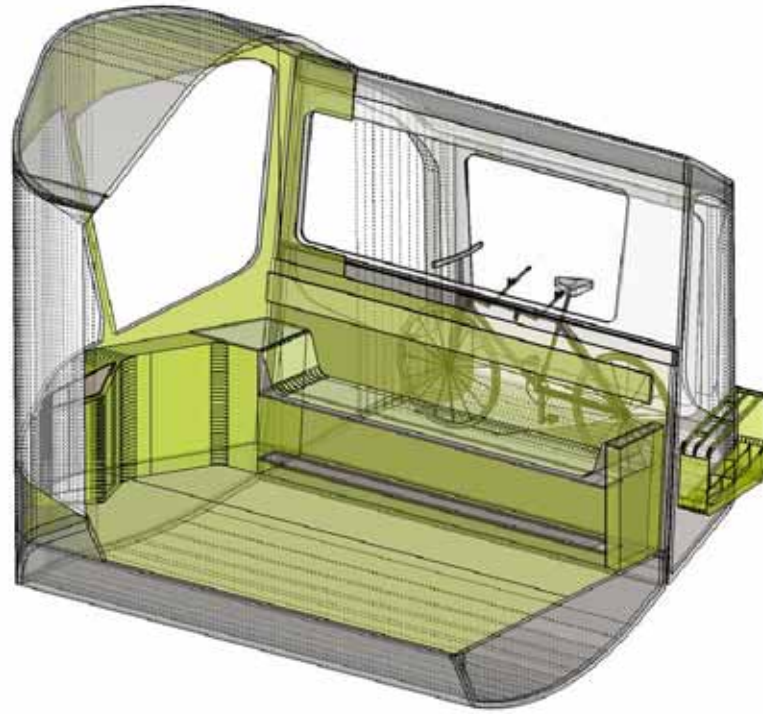

LEGEND -  
SEATER UNIT

4/5 SEATER UNIT B  
NO SCALE

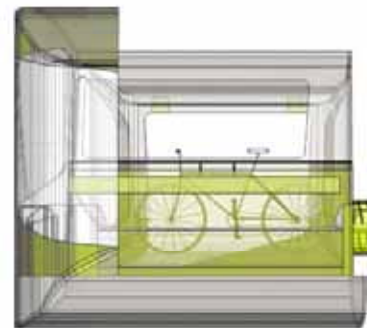



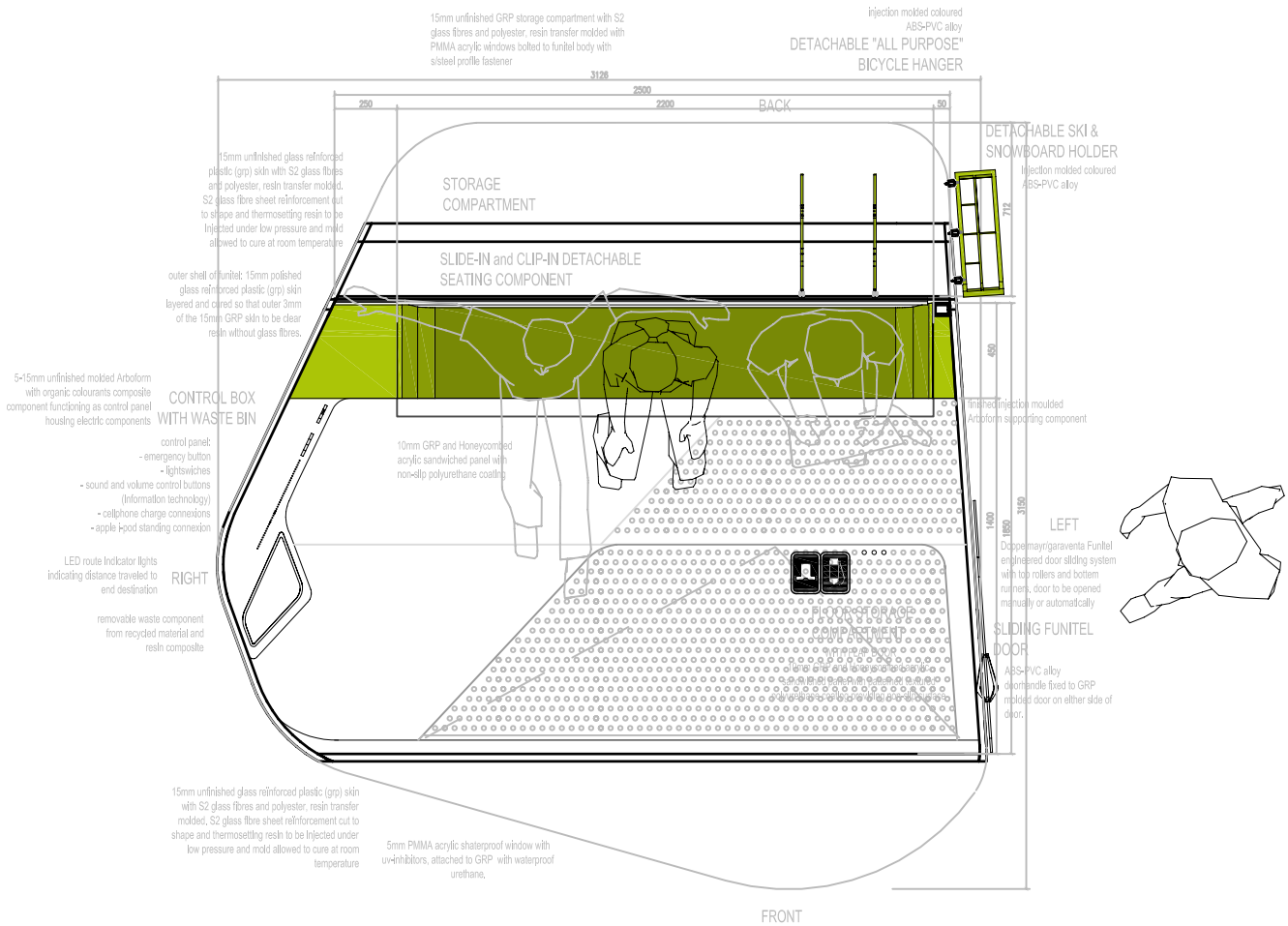

PLAN - 4/5 SEATER UNIT B  
SCALE 1:30

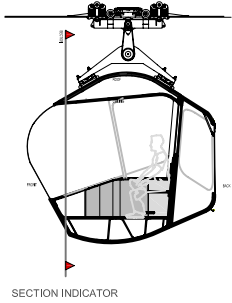

20mm unfinished glass reinforced plastic (grp) skin with S2 glass fibres and polyester, resin transfer molded. S2 glass fibre sheet reinforcement cut to shape and thermosetting resin to be injected under low pressure and mold allowed to cure at room temperature. GRP skin layed and cured so that outer 3mm of the 20mm GRP skin to be clear resin without glass fibres.

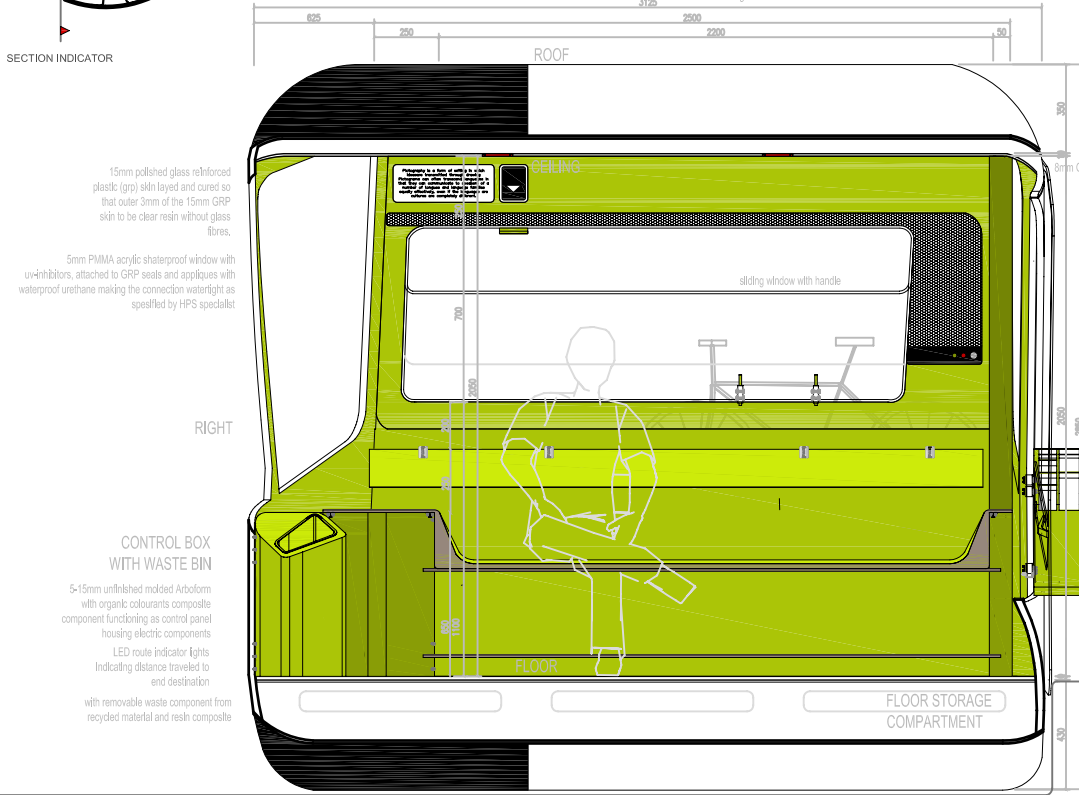

20mm unfinished glass reinforced plastic (grp) skin with S2 glass fibres and polyester, resin transfer molded. S2 glass fibre sheet reinforcement cut to shape and thermosetting resin to be injected under low pressure and mold allowed to cure at room temperature. GRP skin layed and cured so that outer 3mm of the 20mm GRP skin to be clear resin without glass fibres.

SECTION - 4/5 SEATER UNIT B

SCALE 1:30

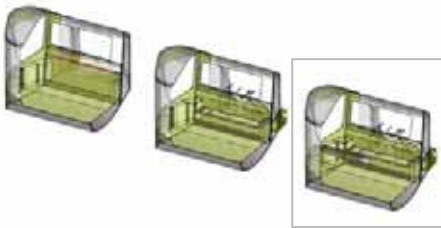
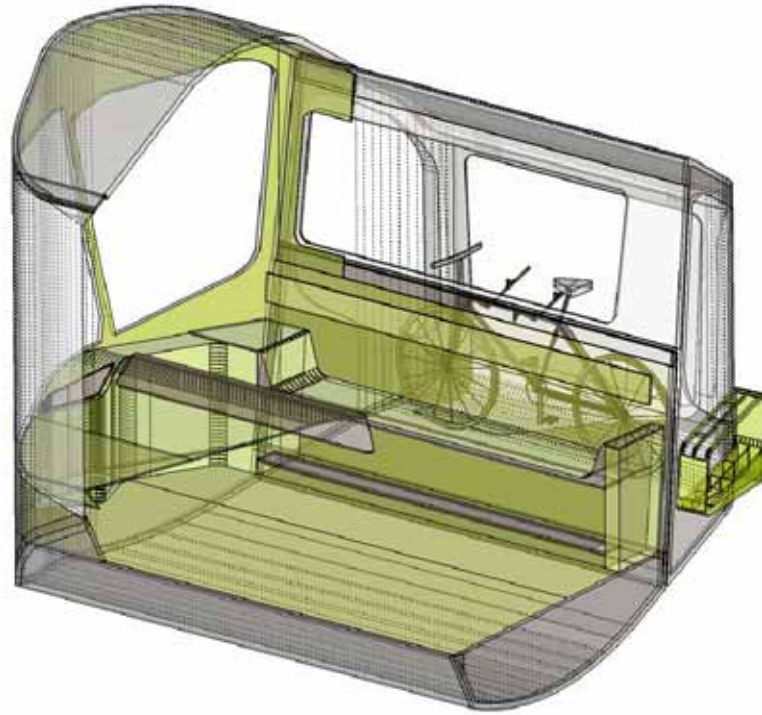

LEGEND -  
"PIC-NIC" UNIT

"PICNIC" UNIT C  
NO SCALE

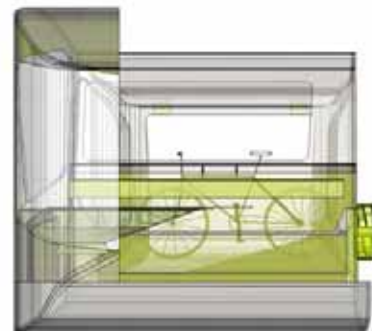

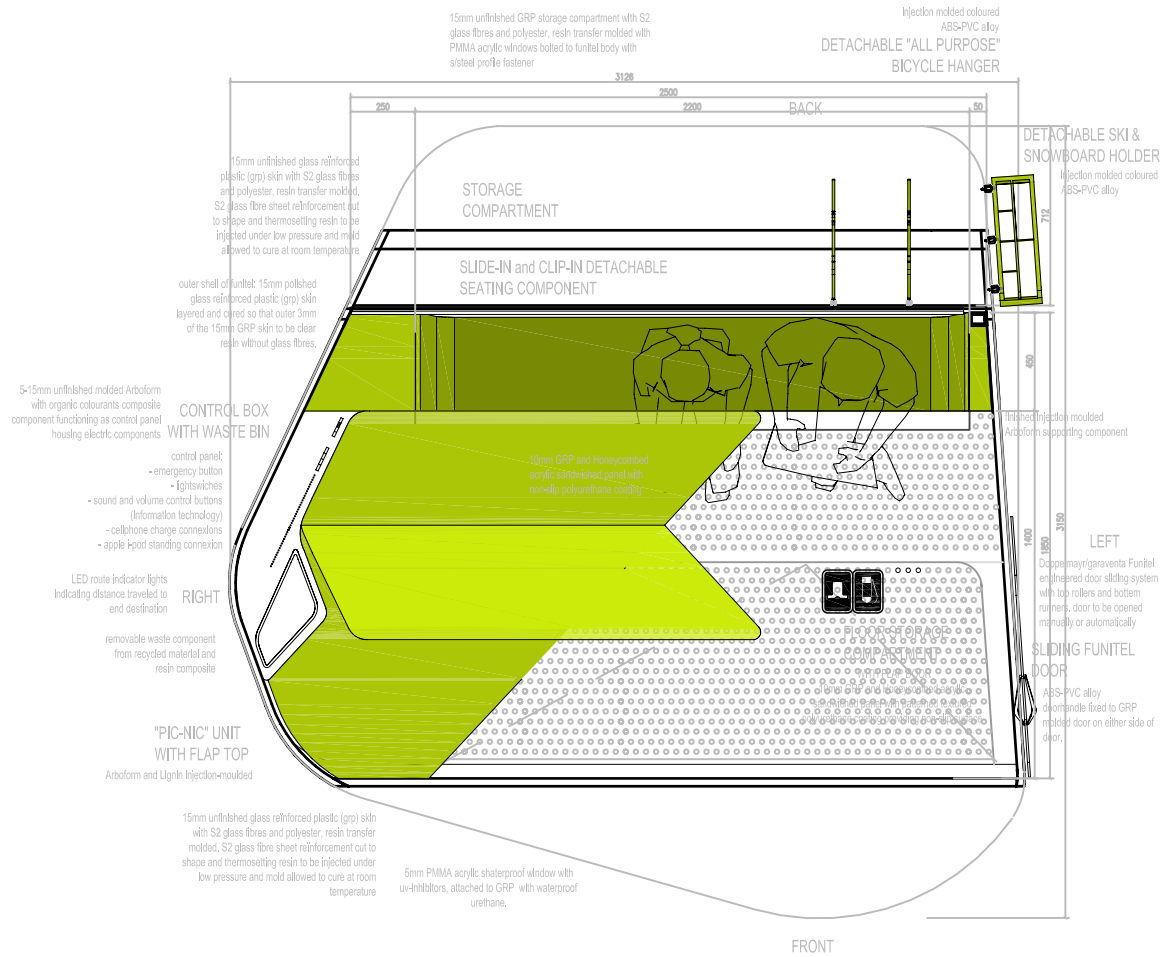

PLAN - "PICNIC" UNIT C

SCALE 1:30

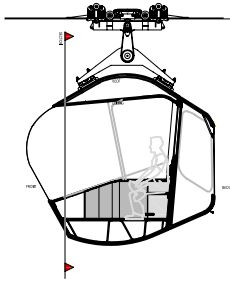

SECTION INDICATOR

20mm unfinished glass reinforced plastic (grp) skin with S2 glass fibres and polyester, resin transfer molded. S2 glass fibre sheet reinforcement cut to shape and thermosetting resin to be injected under low pressure and mold allowed to cure at room temperature. GRP skin layed and cured so that outer 3mm of the 20mm GRP skin to be clear resin without glass fibres.

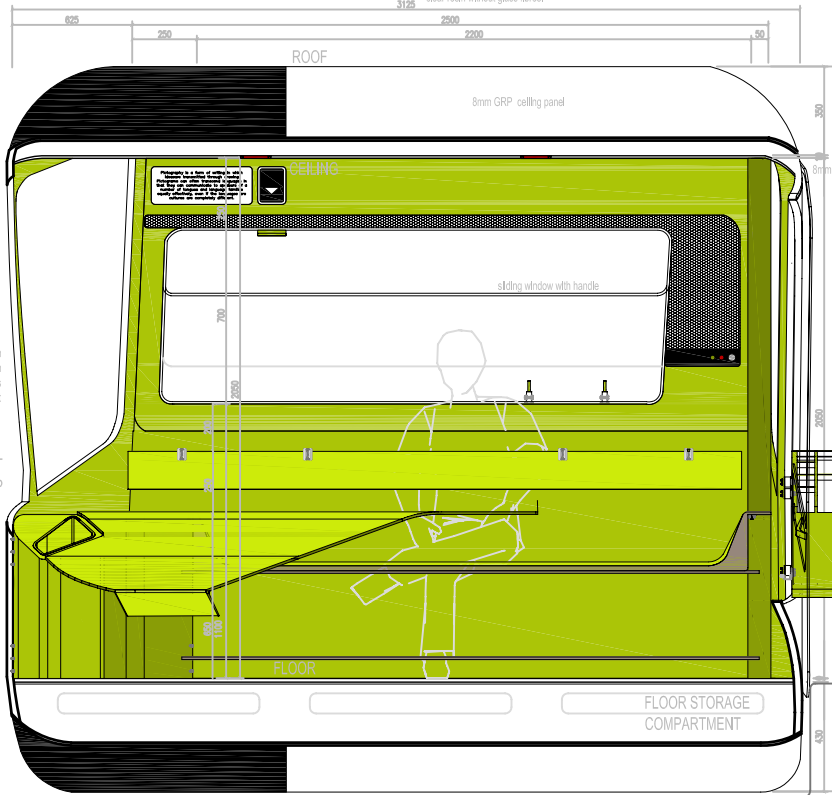

15mm polished glass reinforced plastic (grp) skin layed and cured so that outer 3mm of the 15mm GRP skin to be clear resin without glass fibres.

5mm PMMA acrylic shatterproof window with uv-inhibitors, attached to GRP seals and appliques with waterproof urethane making the connection watertight as specified by HPS specialist

RIGHT

"PIC-NIC" UNIT WITH FLAP TOP

Arboform and Lignin injection-moulded component with clip-in mechanism.

CONTROL BOX WITH WASTE BIN

5-15mm unfinished molded Arboform with organic colourants composite component functioning as control panel housing electric components

LED route indicator lights indicating distance traveled to end destination

with removable waste component from recycled material and resin composite

ROOF

8mm GRP ceiling panel

CEILING

sliding window with handle

FLOOR

FLOOR STORAGE COMPARTMENT

Injection molded coloured ABS-PVC alloy DETACHABLE "ALL PURPOSE" BICYCLE HANGER

SLIDING FUNITEL DOOR

5mm PMMA acrylic shatterproof door glazing with uv-inhibitors, attached to GRP with waterproof urethane.

Doppelmayr/garaventa Funitel engineered door sliding system with top rollers and bottom runners. door to be opened manually or automatically

LEFT

SLIDE-IN DETACHABLE SEATING COMPONENT

15mm finished molded Arboform tough lightweight and lignin resin composite with organic colourants and "Isoskin" cushioning

DETACHABLE SKI & SNOWBOARD HOLDER

Injection molded coloured ABS-PVC alloy RGB 171-197-7



20mm unfinished glass reinforced plastic (grp) skin with S2 glass fibres and polyester, resin transfer molded. S2 glass fibre sheet reinforcement cut to shape and thermosetting resin to be injected under low pressure and mold allowed to cure at room temperature. GRP skin layed and cured so that outer 3mm of the 20mm GRP skin to be clear resin without glass fibres.

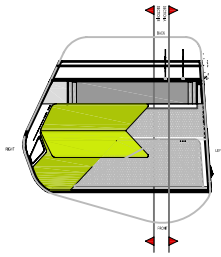

SECTION INDICATOR

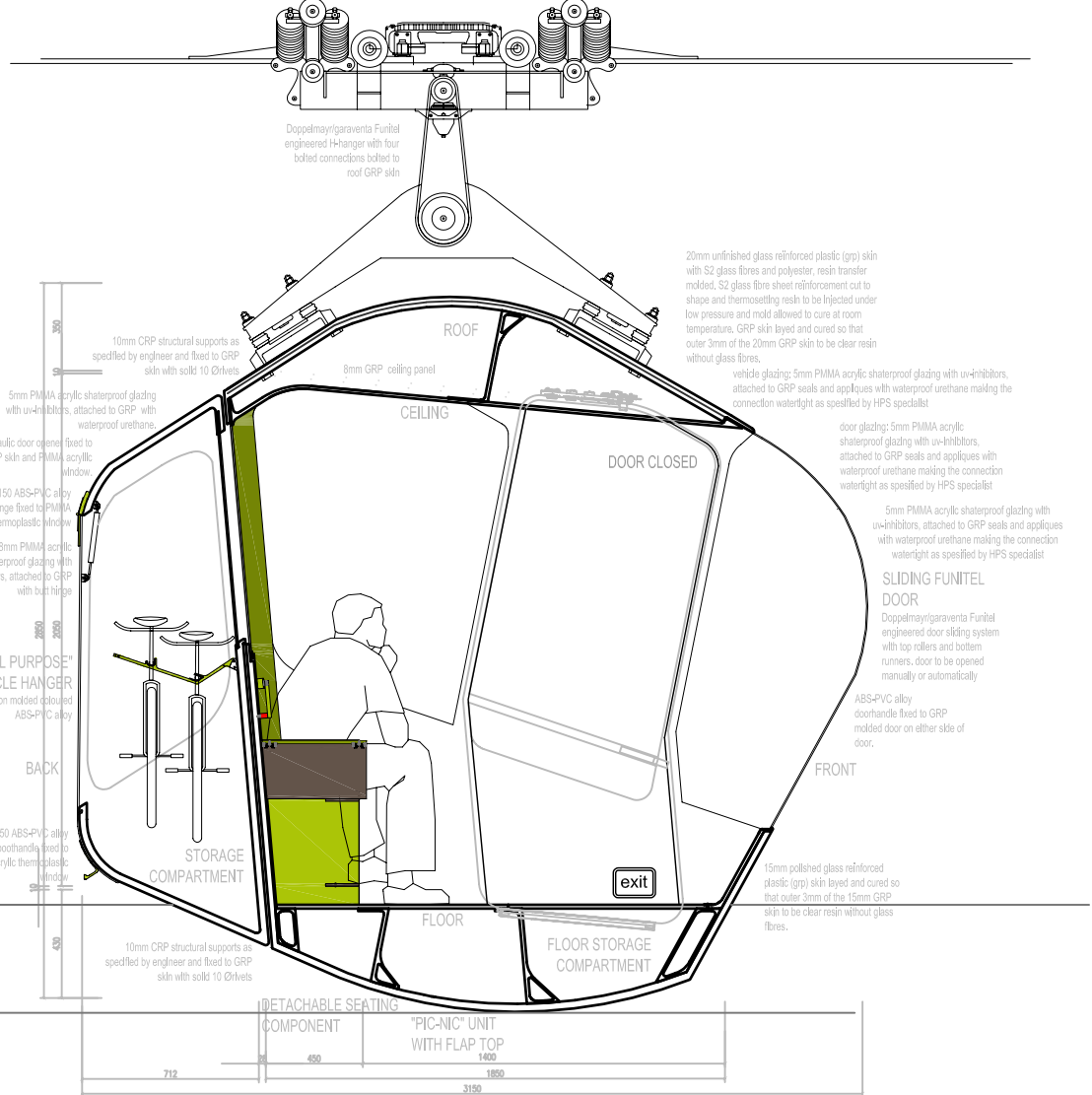

SECTION A: DOOR CLOSED

SCALE 1:30



UNIVERSITEIT VAN PRETORIA  
UNIVERSITY OF PRETORIA  
YUNIBESITHI YA PRETORIA

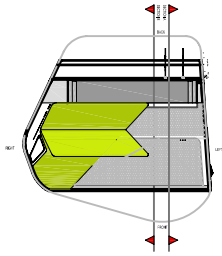

SECTION INDICATOR

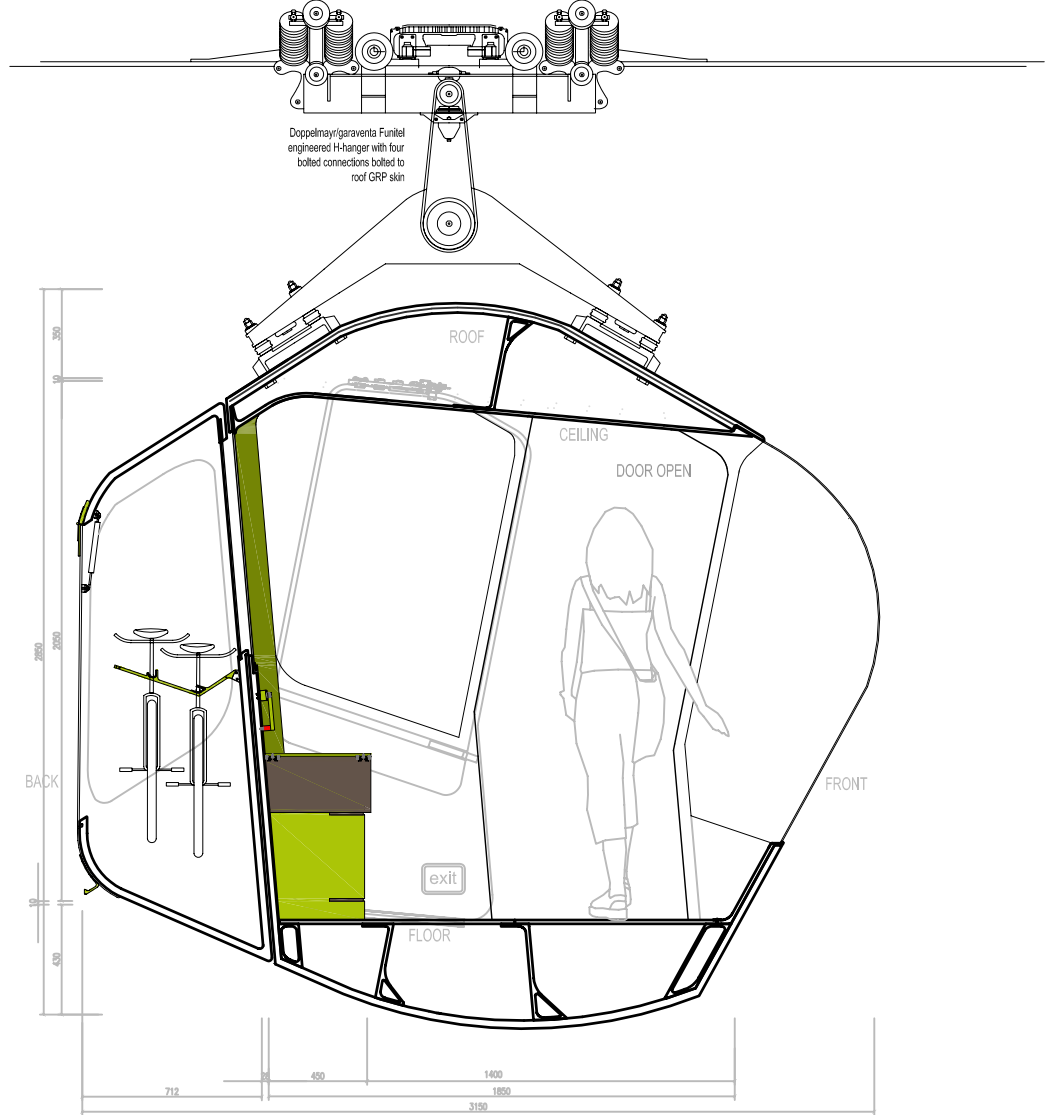

SECTION A : DOOR OPEN

SCALE 1:30

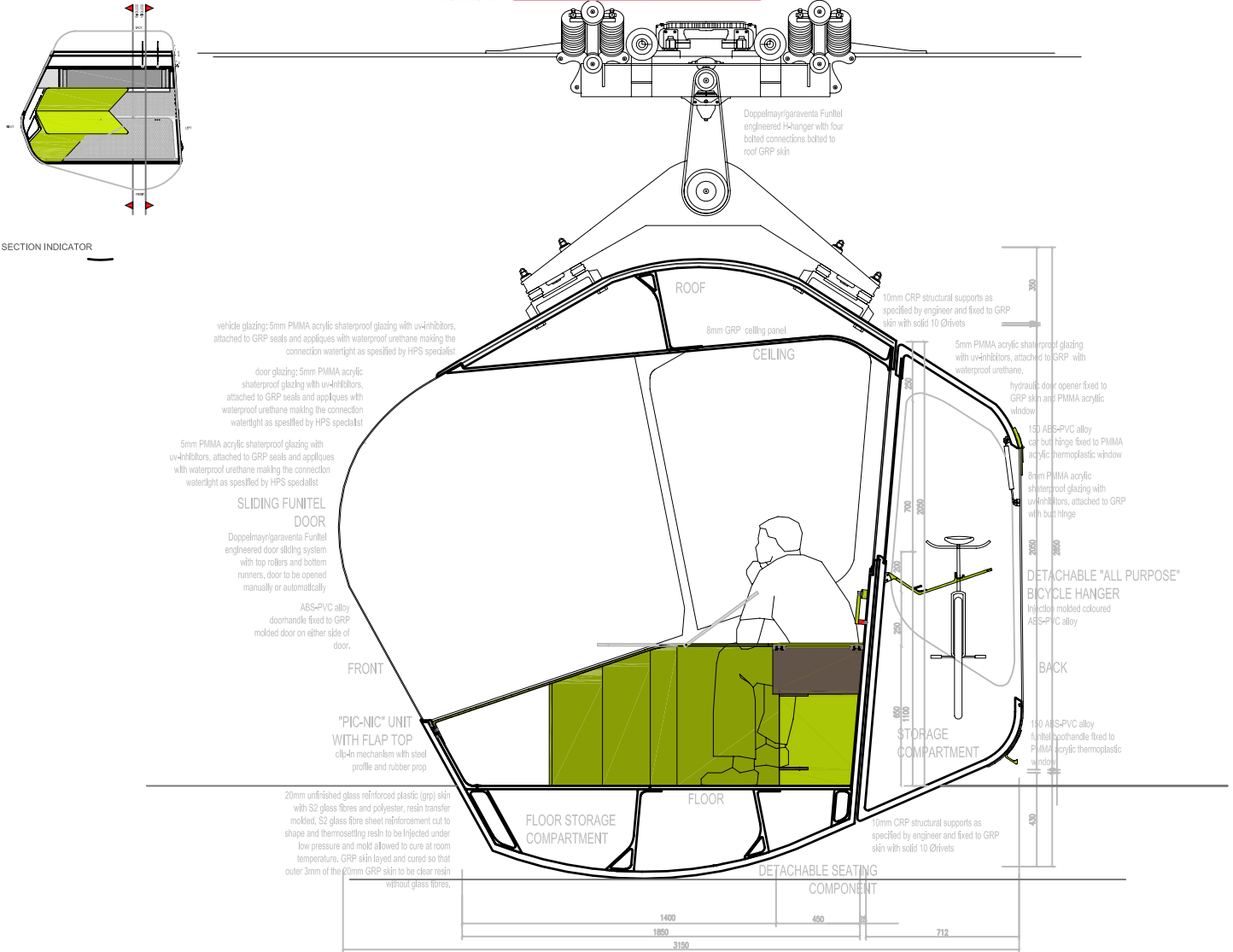

SECTION B  
SCALE 1:30



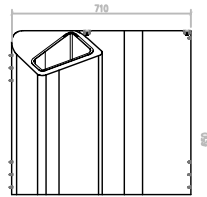

FRONT ELEVATION

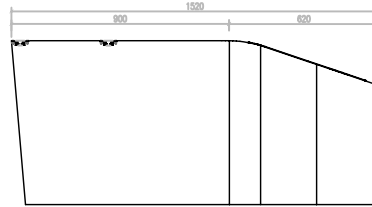

SIDE ELEVATION

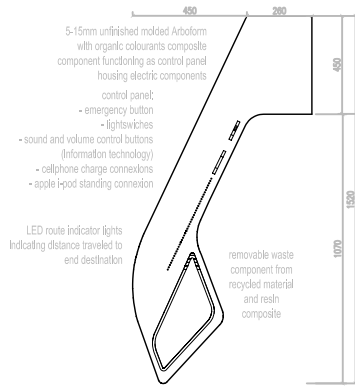
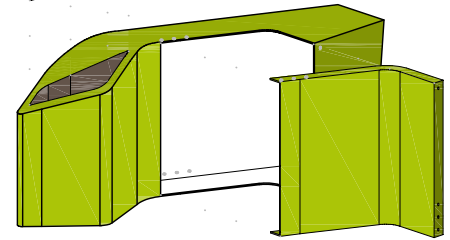
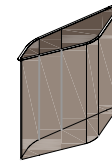

PLAN

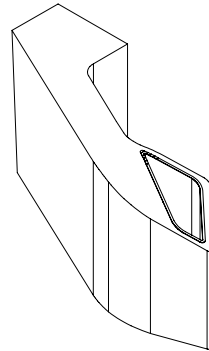

ISOMETRIC VIEW

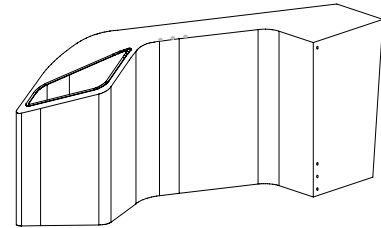

ISOMETRIC VIEW - ASSEMBLY

CONTROL BOX with electronics and waste bin

SCALE 1:30

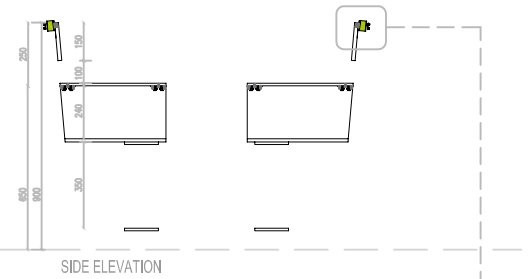
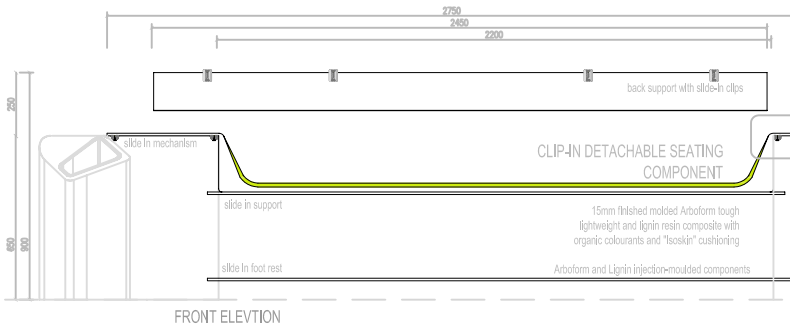
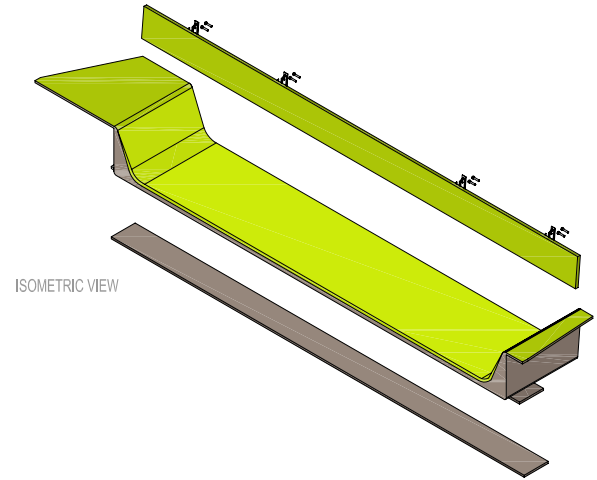
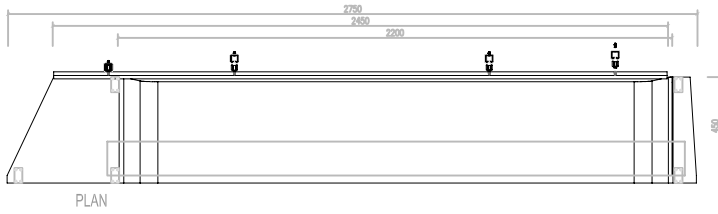

DETACHABLE SLIDE-IN SEATER  
SCALE 1:30

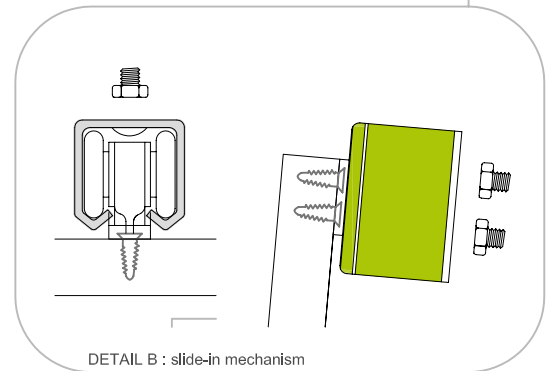
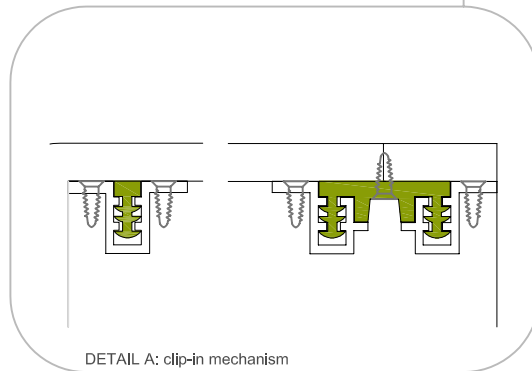



Injection molded coloured ABS-PVC alloy  
RGD 171-197-7  
with rubber grip for bicycle bar and openings for rope grip.

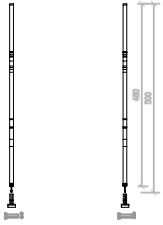

FRONT ELEVATION

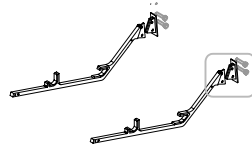

ISOMETRIC VIEW

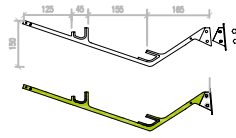

SIDE ELEVATION

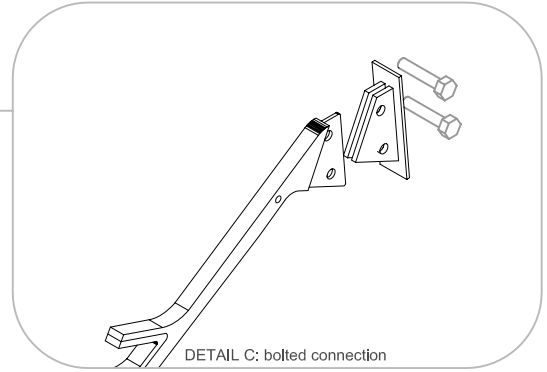

DETAIL C: bolted connection

SCALE 1:4

## MULTI-PURPOSE RACK

SCALE 1:20

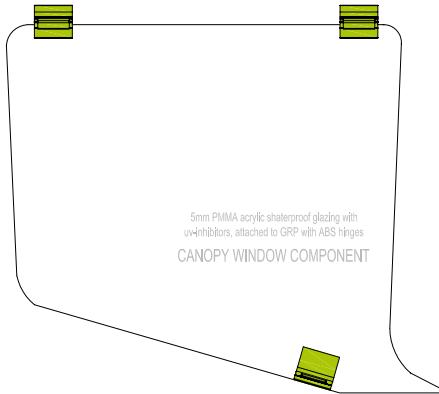

ELEVATION

5mm PMMA acrylic shatterproof glazing with  
uv-inhibitors, attached to GRP with ABS hinges  
CANOPY WINDOW COMPONENT

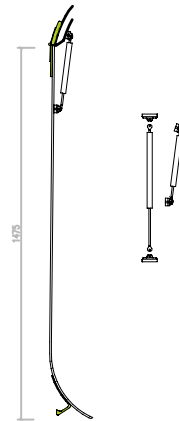

SECTION



## CANOPY WINDOW AND HYDRAULICS

SCALE 1:30

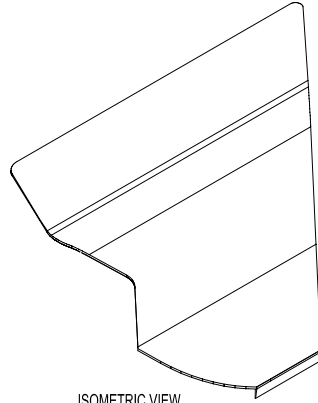

ISOMETRIC VIEW

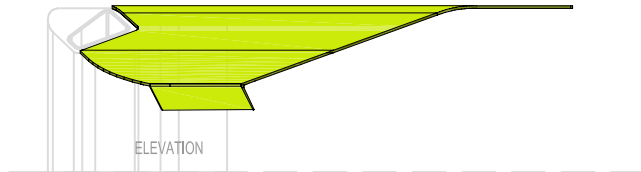
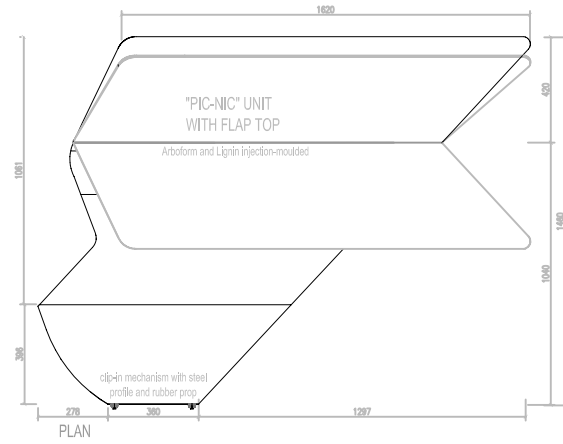
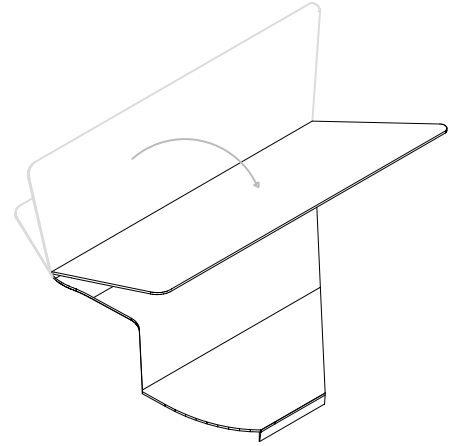

ELEVATION

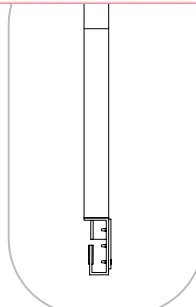

ROLLER DETAIL G: bottom roller  
SCALE 1:4

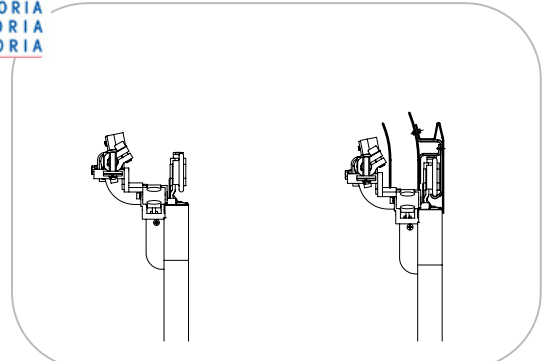

ROLLER DETAIL F: top roller  
SCALE 1:4

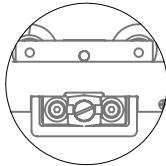

ELEVATION: DETAIL D

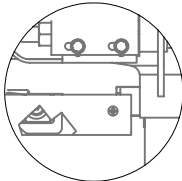

ELEVATION: DETAIL E

5mm PMMA acrylic  
shatterproof glazing with  
uv4inhibitors, attached to GRP  
seals and appliques with  
waterproof urethane making  
the connection watertight as  
specified by HPS specialist

SLIDING FUNITEL  
DOOR

Doppelmayr/paraventis Funitel  
engineered door sliding system  
with top rollers and bottom  
runners, door to be opened  
manually or automatically

ABS-PVC alloy  
doorhandle fixed to GRP  
molded door on either side of  
door.

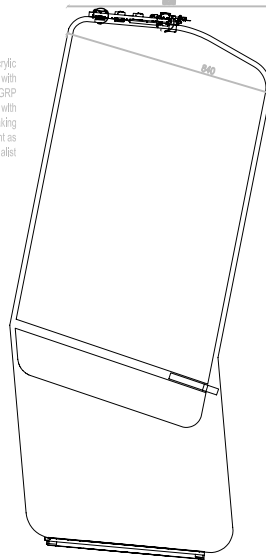

INTERNAL VIEW

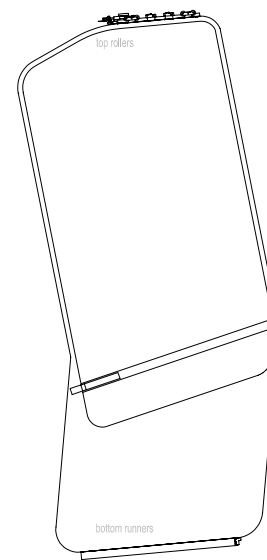

EXTERNAL VIEW

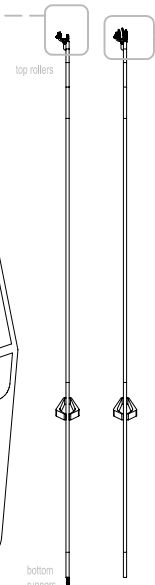

VERTICAL SECTION

SLIDING FUNITEL DOOR

SCALE 1:30

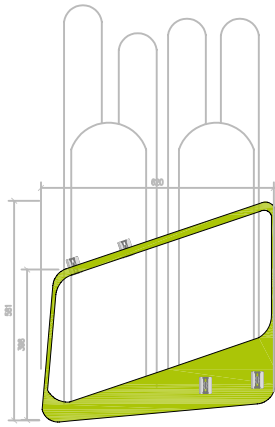

RIGHT ELEVATION

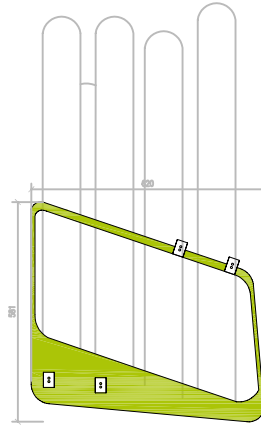

LEFT ELEVATION

injection molded coloured  
ABS-PVC alloy  
RGB 171-197-7

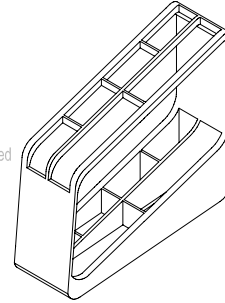

ISOMETRIC VIEW

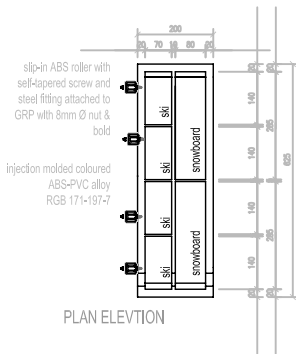
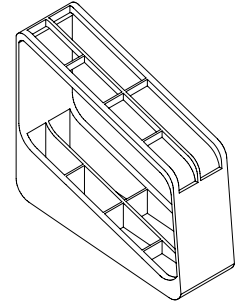

PLAN ELEVATION

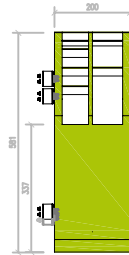

FRONT ELEVATION

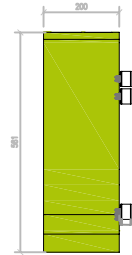

BACK ELEVATION

## SKI AND SNOWBOARD HOLDER

SCALE 1:20



UNIVERSITEIT VAN PRETORIA  
UNIVERSITY OF PRETORIA  
YUNIBESITHI YA PRETORIA



VEHICLE PERSPECTIVE



UNIVERSITEIT VAN PRETORIA  
UNIVERSITY OF PRETORIA  
YUNIBESITHI YA PRETORIA







UNIVERSITEIT VAN PRETORIA  
UNIVERSITY OF PRETORIA  
YUNIBESITHI YA PRETORIA

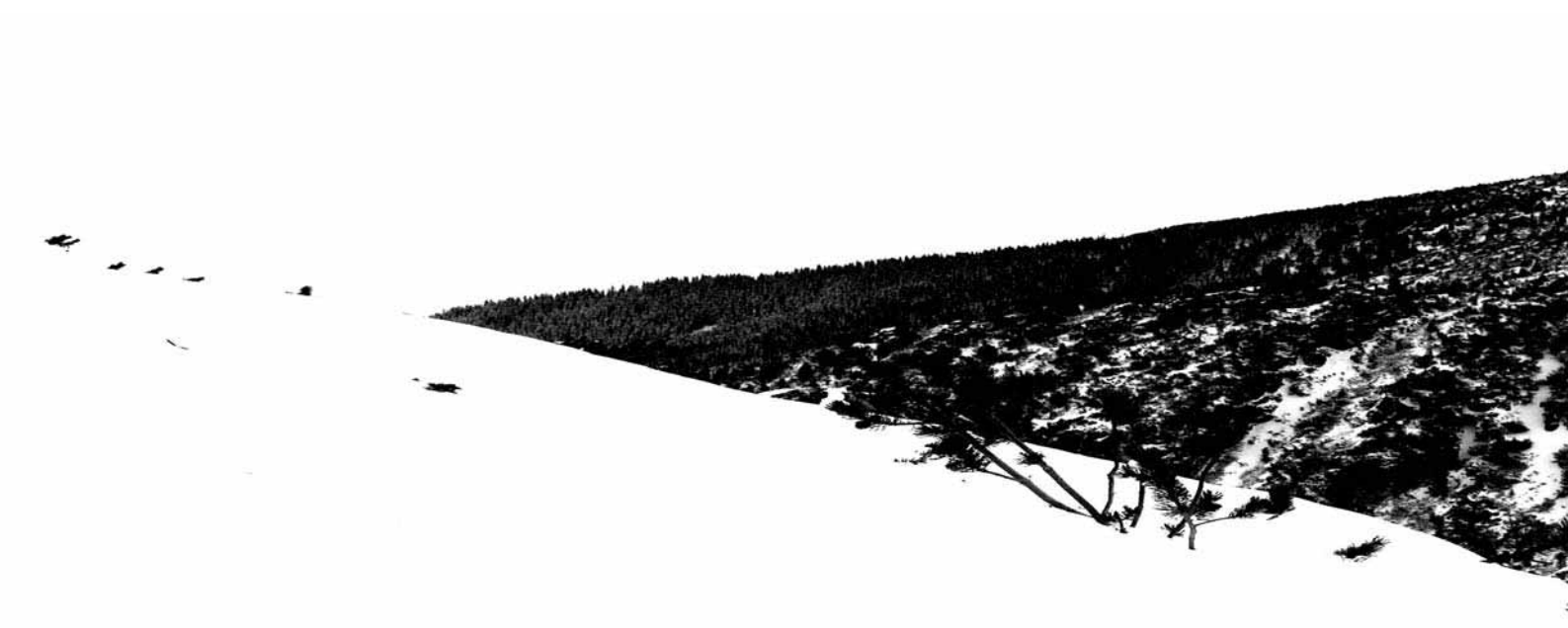



VEHICLE PERSPECTIVE



UNIVERSITEIT VAN PRETORIA  
UNIVERSITY OF PRETORIA  
YUNIBESITHI YA PRETORIA



## BIBLIOGRAPHY

### BOOKS and DOCUMENTATION

Adler, D. 2006. *Metric Handbook: Planning and Design Data*, 2<sup>nd</sup> ed. Oxford: Elsevier Butterworth-Heinemann.

Ashby, M. & Johnson, K. 2002. *Materials and Design: The Art and Science of Material Selection in Product Design*. Oxford: Elsevier Butterworth-Heinemann.

Bookchin, M. 1995. *The Philosophy of Social Ecology*. Montreal: Black Rose Books.

Clark, M. 2006. *The Saga of the Sani Pass and Mokhotlong*. Pietermaritzburg: Teeanem Printers.

Fishel, C. & Gardner, B. 2006. *Logolounge, Volume 3*. Massachusetts: Rockport Publishers.

Hanaor, C. 2006. *Recycle: The Essential Guide*. London: Black Dog Publishing.

Interiors Forum Scotland. 2007. *Thinking Inside the Box*. London: Middlesex University Press, pp.68-71.

Jaggar, A. 1983. *Feminist Politics and Human Nature*. Brighton: Harvester Press.

Lupton, E. 2002. *Skin: Surface, Substance and Design*. Laurence King Publishing.

Massó, P. 2005. *Aircraft Interiors*. Los Angeles: Fusion Publishing.

MINE™. 2005. *Letterhead and Logo Design 9*. Massachusetts: Rockport Publishers.

Moore, H. 2007. Composite Materials [information Sheet] (Personal communication, August 2007)

Olins, W. 2008. *Wally Olins: The Brand Handbook*. London: Thames &Hudson.

Raath, H. 2008. Marion Island New Base and GRP [e-mail] (Personal communication, July 2008)

Raath, H. 2008. Antarctic Halley VI and GRP [e-mail] (Personal communication, October 2008)

Rudolph, A. 2007. Dopplemayr Aerial Transport Systems [information Sheet] (Personal communication, August 2007)

Rudolph, A. 2008. Dopplemayr The Funitel [information Sheet] (Personal communication, May 2008)

Slack, L. 2006. *What is Product design?* Switzerland: Rotovision SA.

Sycholt, A. 2002. *A Guide to the Drakensberg*. Cape Town: Struik Publishers.

Turco, M. 1994. *Visitors' Guide to Lesotho*. Natal: Southern Book Publishers.

*The World Book Encyclopedia*. 1995. s.v. Lesotho, vol. 12. pp.182-184

*The New Encyclopaedia Britannica*. 1986. s.v. Lesotho, 15th ed. pp.296-297 vol. 7

*Grolier Academic Encyclopedia* . 1995. s.v. Lesotho. pp.296-298.

## WORLD WIDE WEB INFORMATION

*Automatic Mass Production: Rivets.* 2007. [online]

Available at: <http://mysite.mweb.co.za/residents/fasteng/Rivets.htm>

[Accessed 10 October 2008].

*Arboform: Engineering, Ethics, Aesthetics.* 2008. [online]

Available at: <http://www.tecnaro.de/english/arboform.htm>

[Accessed 28 April 2008].

British Antarctic Survey: Latest News on Halley VI. 2008. [online]

Available at: [http://www.antarctica.ac.uk/living\\_and\\_working/research\\_stations/halley/halleyvi/](http://www.antarctica.ac.uk/living_and_working/research_stations/halley/halleyvi/)

[Accessed 4 September 2008].

*Chanel Mobile Art Container.* 2008. [online]

Available at: [http://www.chanel-mobileart.com/?lang=en\\_eu](http://www.chanel-mobileart.com/?lang=en_eu)

[Accessed 11 June 2008]

*Chanel Mobile Art Container by Zaha Hadid.* 2008. [online]

Available at: <http://www.ihalife.com/blogs/entries/7008.htm>

[Accessed 11 June 2008].

Doppelmayr/Garaventa Group. 2007. [online]

Available at: <http://www.doppelmayr.com>

[Accessed 4 February 2008].

*Ecolect: Discover Green Materials.* 2007. [online]

Available at: <http://www.ecolect.net/materials/view/arboform>

[Accessed 20 May 2008].

Galzigbahn, St. Anton: History retold and the beginning of a new age. 2007. [online]

Available at: <http://www.ropeways.net/aktuell/galzigbahn/galzigbahn.htm>

[Accessed 20 May 2008].

Galzighbahn. 2008. [online]

Available at: <http://www.driendl.at/index.php?id=51>

[Accessed 20 May 2008].

Halley VI: Antarctic British research stations. 2008. [online]

Available at: [http://www.discoveringantarctica.org.uk/6\\_next.php](http://www.discoveringantarctica.org.uk/6_next.php)

[Accessed 4 September 2008].

Halley VI, 2008. [online]

Available at: <http://www.hbarchitects.co.uk/projects/halley.html>

[Accessed 4 September 2008].

How Products Are Made: Acrylic Plastics. 2007. [online]

Available at: <http://www.enotes.com/how-products-encyclopedia/acrylic-plastic>

[Accessed 20 October 2008].

*Husque: recycled Macadamia Nut by Marc Harrison.* 2008. [online]  
Available at: <http://www.husque.com>  
[Accessed 4 September 2008].

Hydrogen Cars: Honda Puyo. 2007. [online]  
Available at: <http://www.hydrogencarsnow.com/Honda-Puyo.htm>  
[Accessed 20 October 2008].

*JEEP® Vehicles.* 2008. [online]  
Available at: <http://www.jeep.co.za/08cherokee/features/conveniences/>  
[Accessed 21 July 2008].

Maloti Drakensberg Transfrontier Project. 2007. [online]  
Available at: <http://maloti.opencms.co.za/site/>  
[Accessed 20 May 2008].

*Materia: Material Explorer.* 2008. [online]  
Available at: <http://www.materia.nl/575.0.html>  
[Accessed 4 September 2008].

*NorcoGRP: About GRP Products.* 2008. [online]  
Available at: <http://www.norco.co.uk/portal.aspx?mlmenuid=2057&targetportal=51&applicationid=33>  
[Accessed 20 May 2008].

*Paraffin New Media Design: Fueling Brands.* 2008. [online]  
Available at: <http://www.paraffin.co.za>  
[Accessed 17 October 2008].

Poma vehicles: Diamond. 2007. [online]  
Available at: <http://www.poma.net/english/produits/sporthiver/telecabine/diamond/main.htm>  
[Accessed 20 May 2008].

Poma vehicles: 8places. 2007. [online]  
Available at: <http://www.poma.net/english/produits/sporthiver/telecabine/8places/main.htm>  
[Accessed 20 May 2008].

Photo sharing: Ski and Snowboarding. 2007. [online]  
Available at: <http://www.flickr.com>  
[Accessed 4 November 2008].

*Skilifts: Cable Tramway Terms.* 2007. [online]  
Available at: <http://www.skilifts.org/glossary.htm>  
[Accessed 27 September 2008].

*The Cool Hunter: Chanel Mobile Art Container by Zaha Hadid.* 2008. [online]  
Available at: <http://www.thecoolhunter.net/events/Chanel-Mobile-Art-Container-By-Zaha-Hadid/>  
[Accessed 11 September 2008].

*VISAR – Anti Reflection, AR, Coating on Acrylic PMMA.* 2007. [online]  
Available at: [http://www.visionteksystems.co.uk/ar\\_coated\\_acrylic.htm](http://www.visionteksystems.co.uk/ar_coated_acrylic.htm)  
[Accessed 20 October 2008].





Wikipedia: Glass-reinforced plastic. 2008. [online]  
Available at: [http://en.wikipedia.org/wiki/Glass-reinforced\\_plastic](http://en.wikipedia.org/wiki/Glass-reinforced_plastic)  
[Accessed 20 May 2008]

*Zaragoza Bridge Pavilion by Zaha Hadid* 2008. [online]  
Available at: <http://www.dezeen.com/2008/06/16/zaragoza-bridge-pavilion-by-zaha-hadid/>  
[Accessed 4 April 2008].

*Zaragoza Bridge Pavilion in Spain.* 2008. [online]  
Available at: <http://www.tuvie.com/zaragoza-bridge-pavilion-in-spain-as-symbol-of-zaragoza-expo-2008-by-zaha-hadid>  
[Accessed 4 April 2008].

#### RESOURCES FOR INSPIRATION AND CREATIVE THOUGHT

<http://www.architonic.com>  
<http://www.aida-development.de>  
<http://www.brunejair.com>  
<http://www.core77.com>  
<http://www.designboom.com>  
<http://www.design-engine.com>  
<http://www.designsponge.blogspot.com>  
<http://www.dexigner.com>  
<http://www.egganddart.com> , A319 Business Jet  
<http://www.egganddart.com> , A319 Business Jet  
<http://www.framemag.com>  
<http://www.ids-hamburg.de>, Boeing BBJ VIP  
<http://www.mocoloco.com>  
<http://www.placesandspaces.com>  
<http://www.stylepark.com>  
<http://www.swiss.com>  
<http://www.treehugger.com>



Figure 41: mountains and an aerial transport system (Louw:2005)



## APPENDICES 1: TERMINOLOGY AND DEFINITIONS

## TERMINOLOGY AND DEFINITIONS

The field of aerial ropeways is highly specialized and, as such, has its own terminology and definitions, which may be considered unusual. In order to simplify matters, this section is added to provide a basic list of terms used in aerial ropeway technology and design. In some cases, common alternatives are also included.



### AERIAL LIFT:

An aerial lift is a means of transport in which funitels, gondolas or open chairs are hauled above the ground by means of a cable. Types of aerial lifts include: Aerial tramway, funitel, gondola lift, funifor and detachable lift (<http://www.skilifts.org>).



### AERIAL TRAMWAY:

An aerial tramway is a type of aerial lift, often called a cable car or ropeway, and sometimes incorrectly referred to as a gondola. Because of the proliferation of such systems in the Alpine regions of Europe, the French and German language names of Téléphérique and Seilbahn are often also used in an English language context. "Cable car" is the normal term in British English, as in British English the word "tramway" generally refers to a railed street tramway (<http://www.skilifts.org>).



### ANGLE STATION:

A structure at which the lateral direction of the path of the ropeway changes (<http://www.skilifts.org>).



### CABLE CAR

cable car is any of a variety of transportation systems relying on cables to pull vehicles along or lower them at a steady rate, or a vehicle on these systems (<http://www.skilifts.org>).

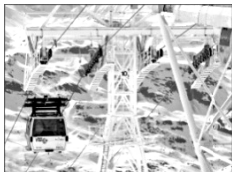

### CARRIAGE:

(Or cabin; car; funitel; gondola; chair; carrier)

The carriage is the vehicle, which carries the passengers (<http://www.skilifts.org>).



DETACHABLE  
CHAIRLIFT:

A detachable chairlift or high-speed chairlift is a type of passenger aerial lift, which, like a fixed-grip chairlift, consists of numerous chairs attached to a constantly moving wire rope (called a *haul rope*) that is strung between two (or more) terminals over intermediate towers. They are now commonplace at all but the smallest of ski resorts. Some are installed at tourist attractions as well as for urban transportation.

The significance of *detachable* chairlift technology is primarily the speed and capacity. Detachable chairlifts move far faster than their fixed-grip brethren, averaging 6 m/s versus a typical fix-grip speed 2.5 m/s. Because the cable moves faster than most passengers could safely disembark and load, each chair is connected to the cable by a powerful spring-loaded cable grip, which detaches at terminals and slows considerably for convenient loading and unloading, typically 1 m/s (<http://www.skilifts.org>).



FUNIFEL:

A Funifor is a type of aerial lift or aerial tramway with two guide ropes and a haul rope loop per cabin. The Funifor design is patented by Doppelmayr Garaventa Group. Two reversible cabins run on parallel tracks. The drives of the two cabins are not interconnected. At the top of each track, the haul rope for that track loops back to the bottom instead of looping over to serve the other track as occurs with a normal aerial tramway. This feature allows for single cabin operation when traffic warrants. The independent drive also allows for evacuations to occur by means of a bridge connected between the two adjacent cabins. The main advantage of the Funifor system is its stability in high wind conditions owing to the horizontal distance between the two guide ropes comprising each track. The Table Mountain Cableway is an example of such a system (<http://www.skilifts.org>).



FUNIFOR:

A Funifor is a type of aerial lift or aerial tramway with two guide ropes and a haul rope loop per cabin. The Funifor design is patented by Doppelmayr Garaventa Group. Two reversible cabins run on parallel tracks. The drives of the two cabins are not interconnected. At the top of each track, the haul rope for that track loops back to the bottom instead of looping over to serve the other track as occurs with a normal aerial tramway. This feature allows for single cabin operation when traffic warrants. The independent drive also allows for evacuations to occur by means of a bridge connected between the two adjacent cabins (<http://www.skilifts.org>).



GONDOLA:

A gondola lift is a type of aerial lift, often called a cable car, which consists of a loop of steel cable that is strung between two stations, sometimes over intermediate supporting towers. The cable is driven by a bullwheel in the terminal, which is connected to an engine or electric motor. Gondolas ropeways offer a highly comfortable ride and this system can be used in ski areas, tourism resorts and the urban environment. The enclosed carriers provide full protection against the elements, and are designed with a strong focus on families and the elderly. Carriers travel through the terminals at creep speed and accelerate to a speed of up to 6m/s. Carrier capacity varies from four to 15 persons, and system capacity can reach 3600 persons per hour (<http://www.skilifts.org>).



**DRIVE**

The "brains" of the lift. The drive is the electronic circuitry which controls the amount of voltage sent to the primary motor of the lift and controls its speed. Modern lifts are powered by Direct Current, controlled by the drive, which allow them to operate very smoothly and efficiently. The drive is also tied in with all of the lift's inline safety circuitry, which shuts down the lift automatically in the event of a problem on the line or in one of the terminals (<http://www.skilifts.org>).

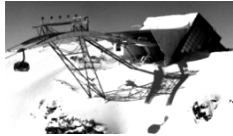

**DRIVE TERMINAL**

The terminal which houses the motor, gearbox, auxiliary engine and drive and safety circuitry. It can be at either the top or the bottom of the lift ("top drive," "bottom drive.") A top drive lift is slightly more energy efficient than a bottom drive lift, but requires the ski area to run electric service to the summit, which can be very costly (<http://www.skilifts.org>).



**MAZE**

The area in which skiers and snowboarders gather while waiting to board a lift. Mazes are designed to optimise chairlift loading. Skiers and riders often call mazes "lift lines" (<http://www.skilifts.org>).



**GRIP: (or clamp)**

The grip is the device, which attaches the hanger to the rope (<http://www.skilifts.org>).



**HANGER:**

The hanger is the load bearing structure from the rope to the carriage (<http://www.skilifts.org>).



**LINE:**

The axis of the rope viewed in plan (<http://www.skilifts.org>).



**MONO-CABLE:**

A mono-cable ropeway is one where the carriage is attached directly to a single rope. This rope performs both the carrying and the hauling functions (<http://www.skilifts.org>).



**MULTI-CABLE:**

Except for the double mono-cable ropeway, multi-cable ropeways are those that allow the carriage to run on wheels on a stationary rope(s) called the track rope. The motive effort is supplied by hauling or moving rope(s) which is attached to the bogie of the supporting wheels. In case of double mono-cable ropeway, the carriage is attached directly to two carrying-hauling ropes (<http://www.skilifts.org>).



**ROPE:**

Rope in aerial ropeway always refers to wire rope consisting of several strands of steel wires and/or spiral ropes. The rope may have a fibre core strand in some cases. The configuration of the wires (or strand) in the rope depends on its duty (<http://www.skilifts.org>).



**TERMINALS:**

Buildings at the ends of a line (stations may be situated at intermediate points in the line). Passengers may embark, transfer or alight only at terminals or stations (<http://www.skilifts.org>).



**TRESTLE/TOWER**

A trestle is a structure of steel or concrete spaced along the line of an aerial ropeway in order to either support or depress the rope to maintain the correct profile and tension characteristics (<http://www.skilifts.org>).

**CABLE CAR RELATED TERMS:**

**ROOF**

Upper covering of a building, car, cavity or space

**CEILING**

An overhead interior surface that bound the upper limit of a space. Generally not a structural element, but a finished surface concealing the underside of the roof structure above

**FLOOR**

The lower horizontal surface of a space and/or the supporting structure underneath it



**APPENDICES2: MANUFACTURING**

## MANUFACTURING

>>

### RESIN TRANSFER MOULDING (RTM)

>

#### Description

Fabrics are laid up as a dry stack of materials. These fabrics are sometimes pre-pressed to the mould shape, and held together by a binder. These 'preforms' are then more easily laid into the mould tool. A second mould tool is then clamped over the first, and resin is injected into the cavity.

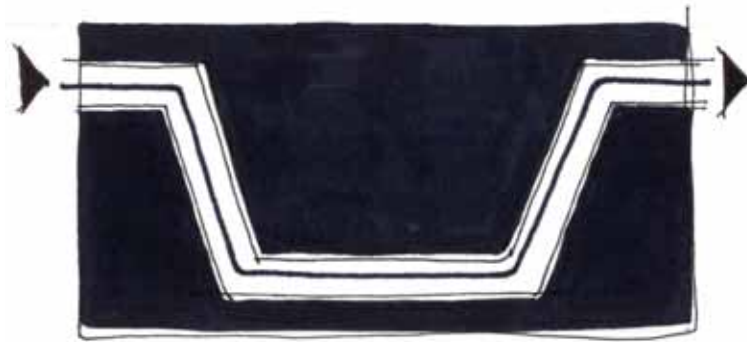

Figure 42: Resin Transfer Moulding (Composite Materials information sheet 2007)

>

#### Main Advantages:

- High fibre volume laminates can be obtained with very low void contents (Moore, 2007).
- Good health and safety, and environmental control due to enclosure of resin (Moore, 2007).
- Possible labour reductions (Moore, 2007).
- Both sides of the component have a moulded surface (Moore, 2007).



>>

WET LAY-UP/HAND LAY-UP

>

#### Description

Resins are impregnated by hand into fibres which are in the form of woven, knitted, stitched or bonded fabrics. This is usually accomplished by rollers or brushes, with an increasing use of nip-roller type impregnators for forcing resin into the fabrics by means of rotating rollers and a bath of resin. Laminates are left to cure under standard atmospheric conditions.



Figure 43 Wet-Lay-Up/Hand Lay-Up (Composite Materials information sheet 2007)

>

#### Main Advantages:

- Widely used for many years (Moore, 2007).
- Simple principles to teach (Moore, 2007).
- Low cost tooling, if room-temperature cure resins are used (Moore, 2007).
- Wide choice of suppliers and material types (Moore, 2007).
- Higher fibre contents, and longer fibres than with spray lay-up (Moore, 2007).

>>

## VACUUM BAGGING

>

### Description

This is basically an extension of the wet lay-up process described above where pressure is applied to the laminate once laid-up in order to improve its consolidation. This is achieved by sealing a plastic film over the wet laid-up laminate and onto the tool. The air under the bag is extracted by a vacuum pump and thus up to one atmosphere of pressure can be applied to the laminate to consolidate it.

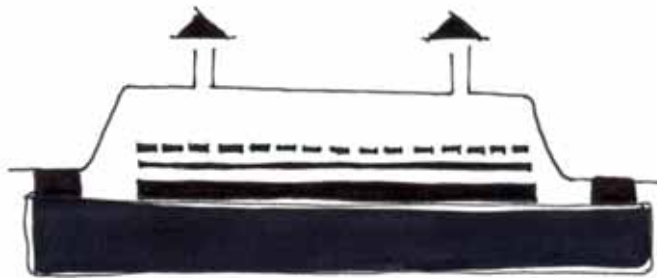

Figure 44: Vacuum Bagging (Composite Materials information sheet 2007)

>

### Main Advantages:

- Higher fibre content laminates can usually be achieved than with standard wet lay-up techniques (Moore, 2007).
- Lower void contents are achieved than with wet lay-up (Moore, 2007).
- Better fibre wet-out due to pressure and resin flow throughout structural fibres, with excess into bagging materials (Moore, 2007).
- Health and safety: The vacuum bag reduces the amount of volatiles emitted during cure (Moore, 2007)

>>  
RESIN FILM INFUSION (RFI)  
>

#### Description

Dry fabrics are laid up interleaved with layers of semi-solid resin film supplied on a release paper. The lay-up is vacuum bagged to remove air through the dry fabrics, and then heated to allow the resin to first melt and flow into the air-free fabrics, and then after a certain time, to cure.



Figure 45: Resin Film Infusion (Composite Materials information sheet 2007)

>  
**Main Advantages:**

- High fibre volumes can be accurately achieved with low void contents (Moore, 2007).
- Good health and safety and a clean lay-up, like prepreg (Moore, 2007).
- High resin mechanical properties due to solid state of initial polymer material and elevated temperature cure (Moore, 2007).
- Potentially lower cost than prepreg, with most of the advantages (Moore, 2007).
- Less likelihood of dry areas than SCRIMP process due to resin travelling through fabric thickness only (Moore, 2007).