

# DESIGNING FOR LIVING SYSTEMS

A LIVING LABORATORY FOR THE UNIVERSITY  
OF PRETORIA'S SOUTH CAMPUS



**Elmie Erasmus**

Mentor and Study Leader:

**Graham Young**

Submitted in the partial fulfilment of  
the requirements for the degree of

**Masters in Landscape Architecture (Professional)**

In the Faculty of Engineering, Built Environment and  
Information Technology

University of Pretoria

Department of Architecture, Landscape Architecture  
and Interior Design.

November 2008



*“My hulp kom van die Here wat hemel en aarde gemaak het.”*

*Psalm 121: 2*

*(Die Bybel, Nuwe vertaling. 1991.)*



*For Willem and my parents, thank you for your love and support.*

<b>Dedication</b>	7	<b>CHAPTER 1- THE PROBLEM AND ITS SETTING</b>	
<b>Contents</b>	8	<b>Introduction</b>	34
<b>List of figures</b>	14	<b>Site</b>	34
<b>List of photos</b>	25	<b>Clients</b>	36
<b>Definition of terms</b>	30	<b>Background</b>	36
		<b>Study objective</b>	38
		<b>Main research question</b>	38
		<b>Sub research questions</b>	38
		<b>Study limitations</b>	39
		<b>Study delimitations</b>	39
		<b>Assumptions</b>	39
		<b>Research method</b>	39
		<b>Validity and reliability</b>	40
		<b>The significance of the study</b>	40

**CONTENTS**



<b>Theoretical Design Philosophy</b>	44
Introduction	44
Degenerative patterns and linear flows	44
Inadequacy of palliatives	45
Designing regenerative systems	45
Aesthetics	46
A different kind of technology	48
Dilemma of development	48
Ecosystemic Approach	48
<b>Overview of Urban Design Theories</b>	49
Traditional urban design	49
Urban ecology	49
Summary	49
Normative design approach	49

# CONTENTS

## CHAPTER 3 – CONTEXT STUDY

<b>Historical Analysis</b>	54	<b>Precinct scale</b>	64
<b>Site specific</b>	54	<b>Study area</b>	64
<b>Contextual</b>	55	<b>Types of urban solids and voids</b>	65
<b>Urban scale</b>	56	<b>Lost space</b>	65
<b>Study area</b>	56	<b>Pedestrian movement</b>	66
<b>Figure ground</b>		<b>Vehicular movement</b>	67
Land uses	57	<b>Visual permeability</b>	68
Ground figure	58	<b>Hydrology</b>	68
<b>Linkage</b>	59	Storm water drainage	68
Visual orientation	59	The wetland system at Pretoria Boys High	68
Edges of buildings	59	<b>Wildlife</b>	69
Transport routes and nodes	59	<b>Future development</b>	69
<b>Place</b>		<b>Site scale</b>	70
Districts	61	<b>Study area</b>	70
Social composition	61	<b>Cadastral information</b>	70
<b>Urban Green</b>	62	<b>Physical area</b>	70
<b>Water bodies</b>	62	<b>Existing site activities</b>	71
		<b>Main pedestrian movement and access</b>	72
		<b>Existing structures</b>	74
		<b>Social activities</b>	75
		<b>Urban voids</b>	76
		<b>Visual orientation</b>	76
		<b>Physical sequence</b>	76
		<b>Linkage</b>	77
		<b>Lost space</b>	77

CONTENTS

## Physical Area Analysis

Surface geology	78
Topography	78
Drainage	78
Vegetation	78
Climate	78
Position of the sun	79

## Legislation

79

## Synthesis

80

Historical synthesis	80
Urban synthesis	80
Precinct synthesis	81
Site synthesis	81
Physical area synthesis	82

## CHAPTER 4 – PRECEDENT STUDIES

<b>Introduction</b>	86
---------------------	----

<b>Precedent 1</b>	86
--------------------	----

Park Duisberg Nord, Emscher Park, Germany

<b>Precedent 2</b>	87
--------------------	----

Parque Ecologico Xochimilco, Mexico City, Mexico

<b>Precedent 3</b>	88
--------------------	----

44 Stanley Avenue, Braamfontein , Johannesburg

<b>Precedent 4</b>	89
--------------------	----

Maurice Rose Airfield Strip, Frankfurt, Germany

<b>Precedent 5</b>	90
--------------------	----

Goteborg, Germany

<b>Precedent 6</b>	92
--------------------	----

Shenyang Architectural University, Shenyang , China

CONTENTS

## CHAPTER 5 –DESIGN PRINCIPLES

<b>Introduction</b>	96
<b>Launch</b>	97
<b>Stratify</b>	97
<b>Fluid</b>	97
<b>Grooming</b>	97
<b>Digestive</b>	97
<b>Translate</b>	97

## CHAPTER 6 - DESIGN RESOLUTION

<b>Program</b>	100
<b>Users</b>	101
<b>Urban Framework</b>	103
<b>Introduction</b>	104
<b>Urban problems</b>	104
<b>Resolutions</b>	104
<b>Vision for South Campus</b>	104
<b>Campus design guidelines</b>	105
<b>New functions and footprints</b>	106
<b>Building design guidelines for newly proposed buildings</b>	108
<b>Circulation and building access points</b>	109
<b>Concept</b>	114
<b>Touchstone project</b>	114
<b>Concept statement</b>	114
<b>Concept development</b>	116
<b>Landscape Framework</b>	119
<b>Introduction</b>	120
<b>Important edges and connections</b>	120
Northern edge toward Lynnwood Road	120
Corners of University and Lynnwood Road	121
The service road	121

CONTENTS

<b>Materials</b>	122	<b>Sketch Plan</b>	149
Timber decking	122		
Cobble stones	122	<b>Sketch plan area</b>	150
Permeable concrete paving	122	<b>Layers</b>	152
Natural stone finishes	122	Soft surfaces and vegetation	153
Existing concrete	122	Hydrology	162
		Hard surfaces	163
<b>Systems</b>	125	Spatial rooms	174
		Lighting	175
<b>Vegetation</b>	126	<b>Technical Resolution</b>	185
River drainage	128		
Grassland	128	<b>Wetland</b>	186
Rocky dry exposed slope	128	<b>Formal open water system</b>	196
Mountain kloof	128	<b>Infiltration trenches</b>	200
<b>Wildlife</b>	138	<b>Stramp</b>	206
<b>Soil</b>	140		
<b>Hydrology</b>	142	<b>CHAPTER 7 – CONCLUSION</b>	214
<b>Air</b>	142		
		<b>CHAPTER 8 – REFERENCES</b>	218
<b>Design Development</b>	145		
		<b>CHAPTER 9 – APPENDICES</b>	
<b>Initial Design Concepts</b>	146	<b>Appendix 1 - U.P Framework</b>	220
Squares	146	<b>Appendix 2 - BRT Route</b>	228
Axis	147		
Buildings	147		
Linking the biophysical and cultural environment	147		

# CONTENTS

## List of Figures

### General

U.P centennial logo. (<http://web.up.ac.za>)

Page 2: Background image of seed germination. (<http://www.infoplease.com>)

Page 4: Background image of seed germination. (<http://www.infoplease.com>)

Page 6: Background image of seed germination. (<http://www.infoplease.com>)

### Chapter 1 - The Problem and its setting

1.10 Location of Centre of Electromagnetism. (*Author*)

1.11 Research method. (*Author*)

1.12 Study methodology. (*Author*)

### Chapter 2 – Theoretical Framework

2.1 Division of study. (*Author*)

2.2 Evolution of land use patterns. (*Lyle, J.T.1994, Regenerative Design for Sustainable Development. United States of America: John Wiley and Sons, Inc.p287*)

2.3 The one way through put system. (*Lyle, J.T.1994, Regenerative Design for Sustainable Development. United States of America: John Wiley and Sons, Inc.p5*)

2.4 The regenerative flow. (*Lyle, J.T.1994, Regenerative Design for Sustainable Development. United States of America: John Wiley and Sons, Inc.p10*)

2.5 The village of Yorkville Park. (<http://www.crave.com/yorkville/ypark-tour.html>.)

2.6 The village of Yorkville Park. (<http://www.virtualtourist.com>)

2.7 The village of Yorkville Park. (<http://www.crave.com/yorkville/ypark-tour.html>.)

2.8 Yorkville Park, sectional vegetation display.  
(<http://www.crave.com/yorkvillephoto'syorkville>.)

LIST OF FIGURES

Background figures:

Page 45: (Hough, M.1994. *Cities and Natural Processes: A Basis for Sustainability*. London: Taylor and Francis Ltd.p.50)

Page 48: (Hough, M.1994. *Cities and Natural Processes: A Basis for Sustainability*. London: Taylor and Francis Ltd.p.49)

Page 49: (Hough, M.1994. *Cities and Natural Processes: A Basis for Sustainability*. London: Taylor and Francis Ltd.p.49)

### Chapter 3 – Context Study

- 3.1 Existing Historical buildings.(*Department of Geography*, University of Pretoria.)
- 3.2 1930 Site buildings. (Pretoria Boys High.2000. *The story of a South African School 1901 – 2001*. Pretoria: ABC Press.)
- 3.3 1940 Site buildings. (Pretoria Boys High.2000. *The story of a South African School 1901 – 2001*. Pretoria: ABC Press.)
- 3.4 1933 CSIR offices. (CSIR.1980. *Fuel Research Institute of South Africa Brochure 1930 – 1980*. Pretoria: CSIR Graphic Arts Division. )
- 3.5 1960 Birds Eye view of CSIR offices. (CSIR.1980. *Fuel Research Institute of South Africa Brochure 1930 – 1980*. Pretoria: CSIR Graphic Arts Division. )
- 3.6 Adjacent site buildings. (Universiteit van Pretoria.1960. *AD Destinatum III, n Geskiedenis van die Universiteit van Pretoria*.)
- 3.7 Study Area. (*Author*)
- 3.8 Land uses. (*Author*)
- 3.9 Ground Figure. (*Author*)
- 3.10 Visual orientation. (*Author*)
- 3.11 Building edges from Lynnwood Road. (*Author*)
- 3.12 Bus routes. (*Author*)
- 3.13 Site within educational cluster. ( *Author*)
- 3.14 Spatial elements of the city. (*Author*)
- 3.15 Districts. (*Author*)
- 3.16 Green areas and water bodies. (*Author*)
- 3.17 Watershed. (*Author*)
- 3.18 Vignette along Lynnwood Road. (*Author*)
- 3.19 Vignette along Lynnwood Road. (*Author*)
- 3.20 Vignette along Lynnwood Road. (*Author*)
- 3.21 Vignette along Lynnwood Road. (*Author*)

# LIST OF FIGURES

- 3.22 Study Area. *(Author)*
- 3.23 Types of urban solids and voids. *(Author)*
- 3.24 Lost space. *(Author)*
- 3.25 Pedestrian movement. *(Author)*
- 3.26 Existing section across Lynnwood Road. *(Author)*
- 3.37 Vehicular movement and bus stops. *(Author)*
- 3.38 Basic storm water drainage. *(Author)*
- 3.49 Channel profile and dimensions. *(Author)*
- 3.51 Site activities. *(Author)*
- 3.52 Pedestrian dispersal and concentration. *(Author)*
- 3.65 On site circulation. *(Author)*
- 3.66 Building grading. *(Author)*
- 3.67 Building access. *(Author)*
- 3.76 Site voids. *(Author)*
- 3.77 Visual orientation. *(Author)*
- 3.78 Physical sequence. *(Author)*
- 3.79 Main linkage. *(Author)*
- 3.80 Lost space. *(Author)*
- 3.81 Slope section. *(Author)*
- 3.82 Main problem. *(Author)*
- 3.83 Eddy spaces. *(Author)*

#### Background Figures

Page 54: (Universiteit van Pretoria.1960. *AD Destinatum III, n Geskiedenis van die Universiteit van Pretoria.*)

# LIST OF FIGURES



## Chapter 4 – Precedent Studies

- 4.1 The promenades of Duisberg Nord Landscape Park. (Baumeister, N. & Pitz, H.2007. *New Landscape Architecture*, Berlin: Verlaghaus Braun.p167.)
- 4.2 A square of trees in the midst of steel giants. (Baumeister, N. & Pitz, H.2007. *New Landscape Architecture*, Berlin: Verlaghaus Braun.p168.)
- 4.3 Parque Ecologico Xochimilco. (<http://www.gdu.com.mx>.)
- 4.4 Aerial representation of Parque Ecologico Xochimilco. (<http://www.gdu.com.mx>)
- 4.9 The Nidda flood plains are coming into their own again. (Baumeister, N & Pitz H.2007. *New Landscape Architecture*, Berlin: Verlaghaus Braun. p181.)
- 4.10 Site plan. (Baumeister, N & Pitz, H.2007. *New Landscape Architecture*, Berlin: p181.)
- 4.11 Primary spatial structure of the city. (Trancki, R.1986. *Finding Lost Space*, New - York: Van Nostrand Reinhold Company.)
- 4.12 Diagram of lost space at the Lilla Bommen. (Trancki, R.1986. *Finding Lost Space*, New - York: Van Nostrand Reinhold Company.)
- 4.13 Proposed infill development at Lilla Bommen. (Trancki, R.1986. *Finding Lost Space*, New - York: Van Nostrand Reinhold Company.)
- 4.14 Diagram of lost space at the Jorntorget. (Trancki, R.1986. *Finding Lost Space*, New - York: Van Nostrand Reinhold Company.)
- 4.15 Proposed infill at the Jorntorget. (Trancki, R.1986. *Finding Lost Space*, New - York: Van Nostrand Reinhold Company.)
- 4.16 Diagram of lost space at the Kingsportsplaten. (Trancki, R.1986. *Finding Lost Space*, New - York: Van Nostrand Reinhold Company.)
- 4.17 Proposed infill at the Kingsportsplaten. (Trancki, R.1986. *Finding Lost Space*, New - York: Van Nostrand Reinhold Company.)
- 4.18 Diagram of lost space at Stenpiren. (Trancki, R.1986. *Finding Lost Space*, New - York: Van Nostrand Reinhold Company.)
- 4.19 Proposed infill at Stenpiren. (Trancki, R.1986. *Finding Lost Space*, New - York: Van Nostrand Reinhold Company.)
- 4.20 Proposed infill at Drottningtarget. (Trancki, R.1986. *Finding Lost Space*, New - York: Van Nostrand Reinhold Company.)
- 4.21 Aerial view of Shenyang Architectural University. (Padua, M.G.2006.Touching the Good Earth, an innovative campus design reconnects students to China's agricultural landscapes. *Landscape Architecture*. December 2006,volume 96, no 12, p100 – 107.)

LIST OF FIGURES

## Chapter 5 – Design Principles

5.1 Design principles. (Author)

5.2 Vertical landscape. (Margolis, L & Robinson, A.2007. *Living Systems: Innovative Materials and Technologies*, Boston: Birkhauser Verlag AG.)

Background figures

Page 96: Jodidio, P.2007. *Architecture Now 4*, Italy:Taschen.

## Chapter 6 – Design Resolution

6.1 Group of people. (<http://www.door2fusion.com>)

6.2 Urban concept. (Author)

6.3 Campus design guidelines. (Author)

6.4 Campus design guidelines. (Author)

6.5 Campus design guidelines. (Author)

6.6 Campus design guidelines. (Author)

6.7 Campus design guidelines. (Author)

6.8 Campus design guidelines. (Author)

6.9 Urban gateway. (Author)

6.10 New site activities. (Author)

6.11 Building envelope. (Kwok, G et al. 2007. *The Green Studio Handbook, Environmental Strategies for Schematic Design*, San Diego: Architectural Press. p.23.)

6.12 Lighting. (Kwok, G et al. 2007. *The Green Studio Handbook, Environmental Strategies for Schematic Design*, San Diego: Architectural Press. p.55.)

6.13 Cooling. (Kwok, G et al. 2007. *The Green Studio Handbook, Environmental Strategies for Schematic Design*, San Diego: Architectural Press. p.137.)

# LIST OF FIGURES

- 6.14 Energy. (Kwok, G *et al.* 2007. *The Green Studio Handbook, Environmental Strategies for Schematic Design*, San Diego: Architectural Press. p.181.)
- 6.15 Water and Waste. (Kwok, G *et al.* 2007. *The Green Studio Handbook, Environmental Strategies for Schematic Design*, San Diego: Architectural Press. p.227.)
- 6.16 Circulation and Building access. (*Author*)
- 6.17 Outdoor Spaces. (*Author*)
- 6.18 Material stitched onto canvas. (*Author*)
- 6.19 Material stitched onto canvas. (*Author*)
- 6.20 Material stitched onto canvas. (*Author*)
- 6.21 Material stitched onto canvas. (*Author*)
- 6.22 Conceptual illustrations of different connections. (*Author*)
- 6.23 Conceptual illustrations of different connections. (*Author*)
- 6.24 Conceptual illustrations of different connections. (*Author*)
- 6.25 Modification of boundary lines along Lynnwood Road. (*Author*)
- 6.26 Earth mound. (Baumeister, N. & Pitz, H, 2007. *New Landscape Architecture, Berlin: Verlaghaus Braun.*p78. )
- 6.27 Functioning of pervious concrete. (*Author*)
- 6.28 Combination of materials used on site. (Baumeister, N. & Pitz, H, 2007. *New Landscape Architecture, Berlin: Verlaghaus Braun.*p96,p110,p265.)
- 6.29 Sections showing the sequence of the construction in process. (Margolis, L. & Robinson, A.2007. *Living Systems: Innovative Materials and Technologies*, Boston: Birkhauser Verlag AG.p114.)
- 6.30 Sections showing the sequence of the construction in process. (Margolis, L. & Robinson, A.2007. *Living Systems: Innovative Materials and Technologies*, Boston: Birkhauser Verlag AG.p114.)
- 6.31 Sections showing the sequence of the construction in process. (Margolis, L. & Robinson, A.2007. *Living Systems: Innovative Materials and Technologies*, Boston: Birkhauser Verlag AG.p114.)
- 6.32 Shrub meadow. (Margolis, L. & Robinson, A.2007. *Living Systems: Innovative Materials and Technologies*, Boston: Birkhauser Verlag AG. p94.)
- 6.33 Distribution of topsoil. Shrub meadow. (Margolis, L. & Robinson, A.2007. *Living Systems: Innovative materials and Technologies*, Boston: Birkhauser Verlag AG. P92.)

# LIST OF FIGURES

- 6.34 Mulching of plantings. (Margolis, L. & Robinson, A.2007. *Living Systems: Innovative materials and Technologies*, Boston: Birkhauser Verlag AG. P92.)
- 6.35 Topographical section. (Author)
- 6.36 Managed succession. (Hough, M.2004. *Cities and Natural Processes: A Basis for Sustainability*, London: Taylor and Francis Ltd.)
- 6.37 Strategic location of vegetation types. (Author)
- 6.38 Tassel Three awn (*Aristida congesta*). (van Oudtshoorn, F.2006. *Guide to Grasse in Southern Africa*. Pretoria. p97.)
- 6.39 Narrow leaved turpentine grass. ( *Cymbopogon plurinoidis* ) (van Oudtshoorn, F.2006. *Guide to Grasse in Southern Africa*. Pretoria. P.53.)
- 6.40 Spear grass ( *Heteropogon contortus* ). (van Oudtshoorn, F.2006. *Guide to Grasse in Southern Africa*. Pretoria. P.66.)
- 6.41 Cork bush (*Mundulea sericea* ) (van Wyk, P & van Wyk ,B.1997. *Field Guide to Trees of Southern Africa*, Cape Town: Struik.p 461.)
- 6.42 Puzzle bush (*Ehretia rigida*) fruit. (van Wyk, P & van Wyk ,B.1997. *Field Guide to Trees of Southern Africa*, Cape Town: Struik.p 163.)
- 6.43 Brack thorn (*Acacia robusta*) flowers. (van Wyk, P & van Wyk ,B.1997. *Field Guide to Trees of Southern Africa*, Cape Town: Struik.p 499.)
- 6.44 Buffalo thorn (*Ziziphus mucronata* ) fruit. (van Wyk, P & van Wyk ,B.1997. *Field Guide to Trees of Southern Africa*, Cape Town: Struik.p 233.)
- 6.45 Small leaved yellowwood ( *Podocarpus falcatus* ) fruit. (van Wyk, P & van Wyk , B.1997. *Field Guide to Trees of Southern Africa*, Cape Town: Struik.p 207.)
- 6.46 Jacket plum (*Pappea capensis*) fruit. (van Wyk, P & van Wyk , B.1997. *Field Guide to Trees of Southern Africa*, Cape Town: Struik.p 223.)
- 6.47 Jacket plum (*Pappea capensis*) flowers. (van Wyk, P & van Wyk , B.1997. *Field Guide to Trees of Southern Africa*, Cape Town: Struik.p 223.)
- 6.48 African olive ( *Olea europea* ) flowers. (van Wyk, P & van Wyk , B.1997. *Field Guide to Trees of Southern Africa*, Cape Town: Struik.p 347.)
- 6.49 Forest num – num (*Carissa bispinosa*) flowers. (van Wyk, P & van Wyk , B.1997. *Field Guide to Trees of Southern Africa*, Cape Town: Struik.p 307.)
- 6.50 Cross berry raisin (*Grewia occidentalis*) flowers. (van Wyk, P & van Wyk , B.1997. *Field Guide to Trees of Southern Africa*, Cape Town: Struik.p 241.)
- 6.51 Forest num – num (*Carissa bispinosa*) fruit. (van Wyk, P & van Wyk , B.1997. *Field Guide to Trees of Southern Africa*, Cape Town: Struik.p 307.)

# LIST OF FIGURES

- 6.52 Cross berry raisin (*Grewia occidentalis*) flowers. (van Wyk, P & van Wyk , B.1997. *Field Guide to Trees of Southern Africa*, Cape Town: Struik.p 241.)
- 6.53 Fever tree (*Acacia xanthophloea* ) flowers. (van Wyk, P & van Wyk , B.1997. *Field Guide to Trees of Southern Africa*, Cape Town: Struik.p 499.)
- 6.54 Dogwood (*Rhamnus prinoides*) fruit. (van Wyk, P & van Wyk , B.1997. *Field Guide to Trees of Southern Africa*, Cape Town: Struik.p 153.)
- 6.55 Fever tree (*Acacia xanthophloea*) fruit. (van Wyk, P & van Wyk , B.1997. *Field Guide to Trees of Southern Africa*, Cape Town: Struik.p 499.)
- 6.56 Long awned grass. (*Aristida stipulate*) (van Oudtshoorn, F.2006. *Guide to Grasse in Southern Africa*. Pretoria. P102.)
- 6.57 River bushwillow (*Combretum erythrophyllum*) (van Wyk, P & van Wyk, B.1997. *Field Guide to Trees of Southern Africa*, Cape Town: Struik.p 331.)
- 6.58 Cross berry raisin (*Grewia occidentalis*) fruit. (van Wyk, P & van Wyk , B.1997. *Field Guide to Trees of Southern Africa*, Cape Town: Struik.p 241.)
- 6.59 Bushman's grape ( *Rhoicissus tridentate*) fruit. (van Wyk, P & van Wyk , B.1997. *Field Guide to Trees of Southern Africa*, Cape Town: Struik.p 393.)
- 6.60 Cross berry raisin (*Grewia occidentalis*) flowers. (van Wyk, P & van Wyk , B.1997. *Field Guide to Trees of Southern Africa*, Cape Town: Struik.p 241.)
- 6.61 Specie Diversity  
 Worms. (<http://www.sports.espn.go.com>)  
 Dragonfly. (<http://www.etc.usf.edu>)  
 Freshwater fish. (<http://www.cmpg.unibe.cb>)  
 Frog. (<http://www.maxwaugh.com>)  
 Ants. (<http://www.lizzyblogspot.com/2008/>)  
 Bee. (<http://www.citybugs.tamu.edu>)  
 Mouse bird. (<http://www.flickr.com/photos/meaghanedwards>)  
 Bush baby. (<http://www.dkimages.com>)  
 Caterpillar. (<http://www.jtbutterflies.com>)  
 Butterfly. (<http://www.fws.gov/Midwest/Seney/butterfly>)  
 Tortoise. (<http://www.wildlife-magnets.com>)  
 Mouse. (<http://www.staffordbc.gov.uk>)  
 Green pigeon. (<http://www.biodiversityexplorer.org/birds/0>)  
 Bat. (<http://www.fs.fed.us/r8/carribean/wildlifefacts>)

# LIST OF FIGURES

Owl. (<http://www.photoramas.files.wordpress>)

All tree species: (van Wyk, P & van Wyk, B.1997.

*Field Guide to Trees of Southern Africa*, Cape Town: Struik.)

- 6.62 Phases in vermiculture. (<http://www.blobalworming.co.za>)
- 6.63 Systemic section through hydrology. (Author)
- 6.64 Conceptual diagrams. (Author)
- 6.65 Conceptual diagrams. (Author)
- 6.66 Conceptual diagrams. (Author)
- 6.67 Conceptual diagrams. (Author)
- 6.68 Conceptual diagrams. (Author)
- 6.69 Conceptual diagrams. (Author)
- 6.70 Orientation key. (Author)
- 6.71 Space in front of the Drama practice rooms. (Author)
- 6.72 Orientation key. (Author)
- 6.73 Boulders. (<http://www.boulderbedrocklandscapeandbouldersupply.com>)
- 6.74 Rhus lancea flowers. (<http://www.jamesdeandesign.com/slide/show/Plantcatalog>)
- 6.75 Space in front of the Drama practice rooms. (Author)
- 6.76 Orientation key. (Author)
- 6.77 Water channel. (Baumeister, N. & Pitz, H, 2007. *New Landscape Architecture*, Berlin: Verlaghaus Braun.p134.)
- 6.78 Water channel. (Baumeister, N. & Pitz, H, 2007. *New Landscape Architecture*, Berlin: Verlaghaus Braun.p134.)
- 6.79 Space in front of the Drama practice rooms. (Author)
- 6.80 Orientation key. (Author)
- 6.81 Timber deck. (Baumeister, N. & Pitz, H, 2007. *New Landscape Architecture*, Berlin: Verlaghaus Braun.p110.)
- 6.82 Wetland species. (Baumeister, N. & Pitz, H, 2007. *New Landscape Architecture*, Berlin: Verlaghaus Braun.p306.)
- 6.83 Tree top view. (Baumeister, N. & Pitz, H, 2007. *New Landscape Architecture*, Berlin: Verlaghaus Braun.p306.)
- 6.84 Wetland edge. (Baumeister, N. & Pitz, H, 2007. *New Landscape Architecture*, Berlin: Verlaghaus Braun.p191.)

# LIST OF FIGURES

- 6.85 Surface rocks which creates habitat. (Margolis, L. & Robinson, A.2007. *Living Systems: Innovative materials and Technologies*, Boston: Birkhauser Verlag AG.p172.)
- 6.86 Western view from the wetland. (Author)
- 6.87 Orientation key. (Author)
- 6.88 Seating blocks. (Baumeister, N. & Pitz, H, 2007. *New Landscape Architecture, Berlin: Verlaghaus Braun.p254.*)
- 6.89 Cobble stone. (Baumeister, N. & Pitz, H, 2007. *New Landscape Architecture, Berlin: Verlaghaus Braun.p254.* )
- 6.90 Space next to the cafeteria. (Author)
- 6.91 Orientation key. (Author)
- 6.92 Tree tops. (Baumeister, N. & Pitz, H, 2007. *New Landscape Architecture, Berlin: Verlaghaus Braun.p119.*)
- 6.93 Space next to cafeteria. (Author)
- 6.94 Orientation key. (Author)
- 6.95 Tree shadows.  
(<http://www.temporaldoor.com/gallery/workshop/brickmoon/treesshadow.>)
- 6.96 Bollards. (Baumeister, N. & Pitz, H, 2007. *New Landscape Architecture, Berlin: Verlaghaus Braun.p231.*)
- 6.97 Space next to the cafeteria. (Author)
- 6.98 Orientation key. (Author)
- 6.99 View through tree canopies. (Baumeister, N. & Pitz, H, 2007. *New Landscape Architecture, Berlin: Verlaghaus Braun.p183.*)
- 6.100 View towards Town and City Planning. (Author)
- 6.101 Orientation key. (Author)
- 6.102 Concrete pots with water plants. (Baumeister, N. & Pitz, H, 2007. *New Landscape Architecture, Berlin: Verlaghaus Braun.p130.*)
- 6.103 Concrete seating rings. (Baumeister, N. & Pitz, H, 2007. *New Landscape Architecture, Berlin: Verlaghaus Braun.p119.*)
- 6.104 Grass and water interface. (Baumeister, N. & Pitz, H, 2007. *New Landscape Architecture, Berlin: Verlaghaus Braun.p121.*)
- 6.105 View towards Town and City Planning. (Author)
- 6.106 Orientation key.(Author)

# LIST OF FIGURES

- 6.107 Aloe marlothii. (<http://www.plantzafrica.com>)
- 6.108 Stone wall. (<http://www.premiercoatings.eu/image/about/clad>)
- 6.109 Ramp access. (Author)
- 6.110 Orientation key. (Author)
- 6.111 Stramp lights. (Baumeister, N. & Pitz, H, 2007. *New Landscape Architecture, Berlin*: Verlagihaus Braun.p318.)
- 6.112 Ramp access. (Author)
- 6.113 Orientation key. (Author)
- 6.114 Concrete surface. (<http://www.wgponds.com/photogallery>)
- 6.115 Glass panels. (<http://www.maddiedigital.co.uk/userimages>)
- 6.116 View from parkade access. (Author)
- 6.117 Orientation key. (Author)
- 6.118 Boulevard of trees. (<http://www.jajones.co.uk/assets/images>)
- 6.119 View from parkade access. (Author)
- 6.120 Concept section. (Author)
- 6.121 Concept section. (Author)
- 6.122 Flow diagram. (Author)
- 6.123 Flow diagram. (Author)
- 6.124 Commensal relationship of wetland species. (Author)
- 6.125 Bentonite clay. (<http://www.naturallygreen.co.uk>)
- 6.126 Bentonite clay. (<http://www.safesolutions.com>)
- 6.127 Orientation key. (Author)
- 6.128 Concept section. (Author)
- 6.129 Orientation key. (Author)
- 6.130 Concept section. (Author)
- 6.131 Spatial view of stramp. (Author)
- 6.132 Concept of vertical landscape. (Margolis, L. & Robinson, A.2007. *Living Systems: Innovative materials and Technologies*, Boston: Birkhauser Verlag AG.p170.)
- 6.133 Stramp model. (Author)
- 6.134 Stramp model. (Author)
- 6.135 Stramp model. (Author)

# LIST OF FIGURES



- 6.136 Concept of vertical garden. (Margolis, L. & Robinson, A.2007. *Living Systems: Innovative materials and Technologies*, Boston: Birkhauser Verlag AG.p170.)
- 6.137 Orientation key. (Author)
- 6.138 Cut in the curb channel. (Margolis, L. & Robinson, A.2007. *Living Systems: Innovative Materials and Technologies*, Boston: Birkhauser Verlag AG. P71.)
- 6.139 A wide street section accommodates stormwater treatment. (Margolis, L. & Robinson, A.2007. *Living Systems: Innovative Materials and Technologies*, Boston: Birkhauser Verlag AG. P71.)
- 6.140 Storm water flow. (Margolis, L. & Robinson, A.2007. *Living Systems: Innovative Materials and Technologies*, Boston: Birkhauser Verlag AG. p70.)
- 6.141 Catchment area. (Author)
- 6.142 Concept section. (Author)
- 6.143 Orientation key. (Author)

Background figures:

Page 114: (Author)

Page 116: (Author)

Page 127: (Margolis, L. & Robinson, A.2007. *Living Systems: Innovative materials and Technologies*, Boston: Birkhauser Verlag AG. P93.)

Page 141: (<http://www.shelbycountyswcd.org>.)

Page 143: (<http://www.freefoto.com>.)  
(<http://www.liquidsculpture.com>)

Page 146: (Author)

Page 147: (Author)

Page 191: (Baumeister, N. & Pitz, H, 2007. *New Landscape Architecture, Berlin*: Verlaghaus Braun.p.313.)

Page 192: (Margolis, L. & Robinson, A.2007. *Living Systems: Innovative materials and Technologies*, Boston: Birkhauser Verlag AG.p104.)

Page 193: (Baumeister, N. & Pitz, H, 2007. *New Landscape Architecture, Berlin*: Verlaghaus Braun.p.201.)

Page 203: (Margolis, L. & Robinson, A.2007. *Living Systems: Innovative materials and Technologies*, Boston: Birkhauser Verlag AG.p170.)

# LIST OF FIGURES

## Chapter 7 – Conclusion

- 7.1 Future urban renewal. (Hough, M.2004. *Cities and Natural Processes: A Basis for Sustainability*, London: Taylor and Francis Ltd.P50.)

## Chapter 9 - Appendices

- 9.1 BRT bus newspaper article. (Claassen, C.2008. *Dis buslis nodig vir 2010*, Beeld,1 Maart.

LIST OF FIGURES

## List of Photos

### General

Page 1: Southern view towards South Campus. *(Author, February 2008)*

### Chapter 1 - The Problem and its setting

- 1.1 Northern view towards Bioengineering department. *(Author, February 2008)*
- 1.2 Eastern view towards Building Economics. *(Author, February 2008)*
- 1.3 Access gate on Lynnwood Road. *(Author, February 2008)*
- 1.4 The site and its context. *(Geography Department, University of Pretoria)*
- 1.5 The site as a microcosm. *(Geography Department, University of Pretoria)*
- 1.6 Remains of the site's industrial past. *(Author, February 2008)*
- 1.7 Store room interior. *(Author, February 2008)*
- 1.8 Remains of the site's industrial past. *(Author, February 2008)*
- 1.9 Centre of Electromagnetism. *(Author, March 2008)*

Background photos:

Page 33: *(Author, February 2008)*

### Chapter 2 – Theoretical Framework

Background photos:

Page 43: *(Author, February 2008)*

### Chapter 3 – Context Study

- 3.27 View from Main Campus. *(Author, February 2008)*
- 3.28 Pedestrian movement across Lynnwood Road. *(Author, February 2008)*
- 3.29 Pedestrian movement across Lynnwood Road. *(Author, February 2008)*
- 3.30 Pedestrian movement across Lynnwood Road. *(Author, February 2008)*
- 3.31 Sequential movement. *(Author, February 2008)*
- 3.32 Sequential movement. *(Author, February 2008)*
- 3.33 Sequential movement. *(Author, February 2008)*
- 3.34 Sequential movement. *(Author, February 2008)*
- 3.35 Sequential movement. *(Author, February 2008)*
- 3.36 Sequential movement. *(Author, February 2008)*
- 3.40 Physical sequence. *(Author, March 2008)*
- 3.41 Physical sequence. *(Author, March 2008)*
- 3.42 Physical sequence. *(Author, March 2008)*
- 3.43 Physical sequence. *(Author, March 2008)*
- 3.44 Physical sequence. *(Author, March 2008)*
- 3.45 Physical sequence. *(Author, March 2008)*
- 3.46 Physical sequence. *(Author, March 2008)*
- 3.47 Physical sequence. *(Author, March 2008)*
- 3.48 Physical sequence. *(Author, March 2008)*
- 3.49 Physical sequence. *(Author, March 2008)*
- 3.50 Physical sequence. *(Author, March 2008)*
- 3.53 Physical sequence. *(Author, March 2008)*
- 3.54 Physical sequence. *(Author, March 2008)*
- 3.55 Physical sequence. *(Author, March 2008)*
- 3.56 Physical sequence. *(Author, March 2008)*
- 3.57 Physical sequence. *(Author, March 2008)*
- 3.58 Physical sequence. *(Author, March 2008)*
- 3.59 Physical sequence. *(Author, March 2008)*
- 3.60 Physical sequence. *(Author, March 2008)*
- 3.61 Physical sequence. *(Author, March 2008)*

LIST OF PHOTOS

- 3.62 Physical sequence. (Author, March 2008)
- 3.63 Physical sequence. (Author, March 2008)
- 3.64 Physical sequence. (Author, March 2008)
- 3.68 Social activity. (Author, April 2008)
- 3.69 Social activity. (Author, April 2008)
- 3.70 Social activity. (Author, April 2008)
- 3.71 Social activity. (Author, April 2008)
- 3.72 Social activity. (Author, April 2008)
- 3.73 Social activity. (Author, April 2008)
- 3.74 Social activity. (Author, April 2008)
- 3.75 Social activity. (Author, April 2008)

Background photos:

- Page 53: (Author, February 2008)
- Page 59: (Author, February 2008)
- Page 60: (Author, February 2008)
- Page 61: (Author, February 2008)
- Page 62: (Author, February 2008)
- Page 64: (Author, February 2008)
- Page 67: (Author, February 2008)
- Page 68: (Author, February 2008)
- Page 69: (Author, February 2008)
- Page 74: (Author, February 2008)
- Page 80: (Author, February 2008)
- Page 81: (Author, February 2008)
- Page 82: (Author, February 2008)

## Chapter 4 – Precedent Studies

- 4.5 Alley between buildings. (Author, March 2008)
- 4.6 Main entrance. (Author, March 2008)
- 4.7 Enclosed space. (Author, March 2008)
- 4.8 Interior courtyard. (Author, March 2008)

Background photos:

- Page 85: (Author, February 2008)

## Chapter 5 – Design Principles

Background photos:

- Page 95: (Author, February 2008)

## Chapter 6 – Design Resolution

Background photos:

- Page 99: (Author, February 2008)
- Page 120: (Author, February 2008)

## Chapter 7 – Conclusion

Background photos:

- Page 213: (Author, February 2008.)

LIST OF PHOTOS

## Chapter 8 - References

Background photos

Page 217: *(Author, February 2008.)*

## Chapter 9 - Appendices

Background photos

Page 223: *(Author, February 2008.)*

LIST OF PHOTOS

## Definition of Terms

**Derelict landscape** - A landscape left in a poor condition due to neglect.

**Dross** - Waste spaces within urbanized areas.

**Ecology** - The study of the relationship of organisms to their environment and to one another.

**Ecosystem** - A biological community of interacting organisms and their physical environment.

**Environmental ethic** – Using moral principles to impose order on the physical and spatial components of the environment in order to improve the human condition by influencing the cultural and biological components.

**Natural processes** – Processes which are produced and maintained by nature.

**Microcosm** – A thing regarded as encapsulating in miniature the characteristics of something much larger.

**Phenomena** – A remarkable thing that is observed.

**Phenomenology** - An approach that concentrates on the study of the consciousness and the objects of the direct study.

**Recovering** – To return to a normal state of health.

**Regenerative design** – Replacing the present linear system of throughput flows with cyclical flows at resource consumption centres, and sinks.

**Rehabilitation** – The rehabilitation of land is necessary after man's activities have disturbed it so that it cannot recover naturally.

**Remediation** – The action of remedying the landscape.

**Sustainable design** – Design that meets the needs of the present generation without compromising the ability of future generations to meet their needs.

*(The Concise Oxford English Dictionary.2002.)*

TERMS

# CHAPTER 1

## THE PROBLEM AND ITS SETTING

## CHAPTER 1

### THE PROBLEM AND ITS SETTING

#### Introduction

The University of Pretoria is celebrating its 100<sup>th</sup> year anniversary. In 2008 the Department of Landscape Architecture has requested that the final year Landscape Architectural students choose a site within the university owned land as a thesis for their dissertation.

#### Site

South Campus is a strip of land lying south of the University of Pretoria's Main Campus. This site will serve as the chosen site for the dissertation. The borders include Lynnwood Road which lies to its north; and Pretoria Boys High sport grounds forms the southern border. The eastern border and western border consists of Pretoria East Primary School and University Road respectively. Formerly the site was used for the CSIR's Coal Research Division. Presently various departments such as, Drama, Fine Arts, Town and City Planning, Chemical Engineering's (division: water utilisation), Biotechnology and Construction



Fig. 1.1 Northern view towards Bioengineering department.



Fig. 1.2 Eastern view towards Building Economics.



Fig. 1.3 Access gate on Lynnwood Road.

Economics have lecture rooms or laboratories on South Campus. Other facilities and activities include, the UP Press, a kiosk, Centre for Electromagnetism, store rooms, and Coin Security administration offices.

As a result of Lynnwood Road the site is isolated and separated from Main Campus. The spaces in between the buildings do not exist as an active social, cultural and ecological resource for neither the University of Pretoria, nor the city. Within the site it is evident that there are a number of spaces between buildings, paths and activity areas, which are underutilised, left open and abandoned. Thus there exist opportunities to apply regenerative methods in order to connect the fragmented pieces by means of embracing ecology and juxtaposing the total industrial opposite. *“These strange places exist outside the city’s effective circuits and productive structures. From the economic point of view, industrial areas, railway stations, ports, unsafe residential neighbourhoods and contaminated places are where the city is no longer.” In short they are foreign to the urban system, mentally exterior in the physical interior of the city, its negative image as much a critique as a possible alternative.” (Waldheim, C.2003.p35.)*



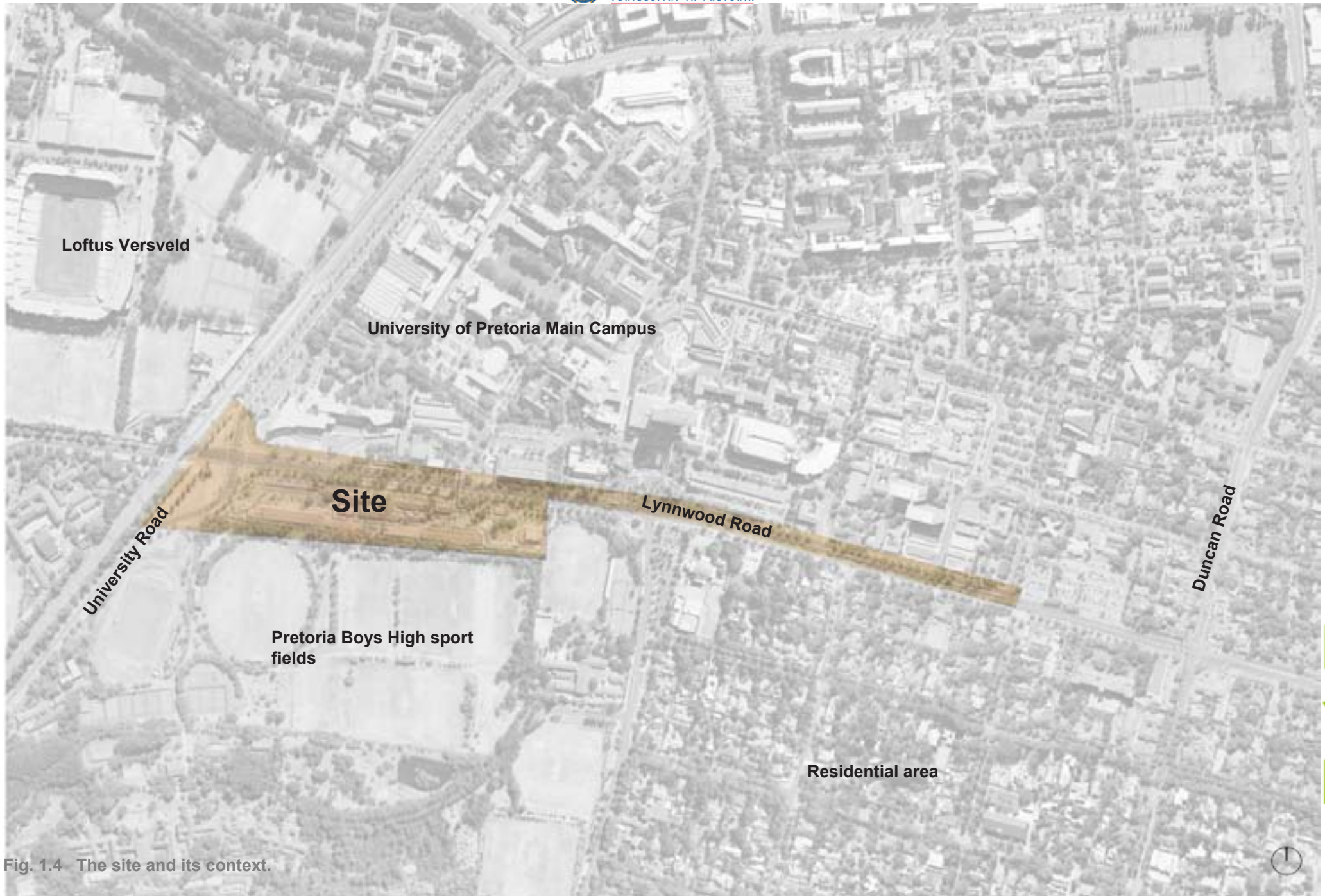

Fig. 1.4 The site and its context.



The chosen site is not an under utilised waste landscape , but it is an analogy of a waste landscape due to the ad hoc placement of buildings and numerous shifts between program and users. The site will be viewed as a **microcosm** of the larger environment, thus the evolved landscape will provide a model for future urban development.



Fig. 1.5 The site as a microcosm.

## Clients

- University of Pretoria

The client for the proposed new landscape design on the South Campus of the University of Pretoria can be described as a partnership of a number of role players. It will be a collaboration of various facilities of the University of Pretoria, especially the Engineering, Built Environment and Fine Arts departments.

- The City of Tshwane

The City of Tshwane's Municipality will be the main client of design proposals outside of university owned land.

## Background

Left over spaces in between buildings or spaces left abandoned by previous industrial or economic activities do not contribute to the cities health, because they are derelict, fragmented parcels of land. Adaptively reusing waste spaces figures to be one of the present as well as the future's great design challenges for Landscape Architects. The term "*dross*" has been used to explain these left over, in between wasted areas, evident in most cities throughout the world.

*"It is no longer seen as an evil, it has merits and productive possibilities and it is a link in the continuous flow of matter and energy."* (Waldheim, C.2003.p35.) The formal city landscapes imposed over the original natural diversity are the areas in need of rehabilitation. (Hough, M. 2004). The concept of recovering and rehabilitating fragmented sites is not new (Cerver, F.A 1996?). Landscape Architects seized the initiative of adapting to changing conditions and constructed new forms of space. The recovery of

landscape began by the creation of the “filter of vegetation”; landscape was here promoted as a palliative to modern urbanization. After this period, Landscape Architects began to look more intensely and creatively at the unique specificity of sites, especially at the borders and edges, the areas neglected by architects. By doing this, Landscape Architects took advantage of any opportunity to repair the damage and to create a sense of place. The recognition of a dialectical relationship between landscape and public space, emphasise the significance of recovery. (Marot, S.1999.)

As humans we are the steward of the biosphere, therefore we have an obligation and must start dealing with these issues within the city environment, focusing on sites which are in need of remediation and regeneration. It is for these reasons, that we should re-establish some connections which were lost by industrialization and commemorate them through design. (Lyle, J.T.1994.)

Urban environments, just like humans are not separate from nature and it is vital that we see ourselves as a central part of the living community (Royal Commission on the Future of the Waterfront.1992.) Traditional design values which have shaped the landscape have only slightly contributed to our environmental well being. Most well known urban design principles, from theorists and designers such as Lynch, Trancick and Bentley have little connection with living systems and natural or ecological processes. Although these principles are fundamental for urban design, they still fail in making the connection. It is fundamental for society to understand basic ecology and enable them to maintain ecological quality (Nassauer, J.I. 1995). Sadly this view is, to a large extend, mostly evident in some developed countries which started addressing such issues prior to developing countries.

As landscape architects we should visually communicate a healthy environmental ethic, as Robert Thayer states “transparent landscapes – the ability to see into and understand the inner workings of a landscape.” (Corner, J.1999.p189.) Visible ecological function must be actively

represented for human experience, these left over spaces in between buildings and in the city gives us the ideal opportunity to illustrate such functions. It is important to first understand the city as part of nature before we can begin to cure the wounds inflicted on it and restore its flows, and design its forms so that the landscape function as a regenerative system. (Royal Commission on the Future of the Waterfront.1992)

Lyle refers to Odum (1993) “Current cities are parasites that, unlike successful parasites in nature, have not evolved mutual aid relationships with their life support host landscape that prevent the parasite from killing off its host and thereby itself.” (Lyle, J.T.1994.p5) This situation is implying that human design processes have linear time dimensions, unlike nature’s recycling flow. Ultimately this one way system will destroy the landscape on which it depends (Lyle, J.T.1994.)

City elements decrease the function and the mixture of the natural ecosystem. (Ruff, A.1982.) We can’t eliminate cities, nor would we want to, but we must realise that cities separate us from nature and each other. They exist by draining resources from the planet, while distributing toxic materials and waste, therefore we must find design methods to minimize these impacts (Cerver, F. A 1996?) .

By admitting that we still don’t have enough ecological understanding to complete the job confidently, we must recognise that we have no choice because time is running out (Lyle, J.T. 1985.). By changing our local environment, we should not just rehabilitate but also add natural processes into the existing systems. There is a need to design our cities in a manner which is green and sustainable. A critical purpose in sustainable landscapes is the relationship between environment and society, thus we must start to understand the bioregion its natural processes and how the people affected the natural processes presently as well as in the past.



Fig. 1.6 Remains of the site’s industrial past.

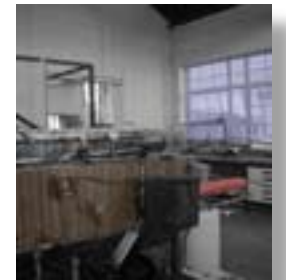

Fig. 1.7 Store room interior.



Fig. 1.8 Remains of the site’s industrial past.

“We are starting to exhaust the capacity of the very systems that sustain us and now we must deal with the consequences.” (J.Zanzot.2007.) Over the last century we have designed the landscape, in ways which are in contrast from nature’s principles. Through writings of Carson (1962), Commoner (1990) and Ehrlich (1987) it became evident that future survival would rely on man’s capacity to work within the limits of the environment. (Ruff, A.1982.)

The environmental crises we are facing are in many ways a design issue, an issue which needs to be addressed holistically. The blending of stability and change will require a specific approach which will reshape the landscape different from those of the past. (Lyle, J.T.1994.)

## Study Objective

Detached, fragmented spaces in between buildings are evident throughout the University of Pretoria’s South Campus. There have been attempts to integrate these, but it has not been dealt with in a sustainable manner. This dissertation proposes to evaluate contemporary and historical theories in order to formulate a theoretical base, a suitable design approach and normative position. It will further investigate the site and its context; establish how local and international precedents have contributed to the recovering of urban landscapes and open spaces, as well as formulating appropriate regenerative design principles. The open fragmented spaces of the University of Pretoria’s South Campus will then be integrated through the application of regenerative design principles to serve as a model for the bigger urban environment.

## Main research question

How can modern, technologically advanced regenerative design principles be applied on a small scale urban site in order to connect fragmented open spaces, and if so, can this site serve as a model for larger scale urban projects?

## Sub research questions

The first sub question: What theories will be investigated to find a suitable design approach?

The second sub question: How will design opportunities be identified?

The third sub question: How have local and international precedents contributed to the recovering and integration of urban spaces and/or landscapes?

The fourth sub question: What are the innovative, regenerative design principles and what do they entail?

The fifth sub question: How can innovative regenerative principles be applied as linking elements in the urban landscape environment?



Fig. 1.9 Centre of Electromagnetism.

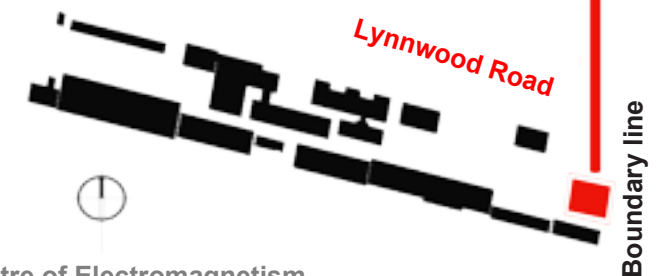

Fig. 1.10 Location of Centre of Electromagnetism.

## Study limitations

The University of Pretoria is celebrating its 100<sup>th</sup> year anniversary; therefore the study can only be done on university property. This is an opportunity as amongst institutions of modern society, the university, with its wide field of expertise and its inquisitive character, offers a unique setting for exploring the technological, aesthetic and social meanings of a regenerative future.

The Centre of Electromagnetism situated on the eastern side of the site has a 15m boundary line around the building, no roads or enclosed structures are allowed within this area.

## Study delimitations

- Regenerative principles as a productive food source are not taken into consideration.
- The treatment of raw sewage.
- The calculations of water quality

## Assumptions

- Pretoria Boys High will agree to sell a portion of land (which is not presently in use) to the University of Pretoria
- The BRT stop will be established on the corner of Lynnwood and University Road within the near future.(Refer to appendix 2)
- The existing activities on the site will remain as they are.
- The University of Pretoria will sell 8m on each side of Lynnwood Road where necessary.

## Research Method

The method of study will be based largely on a qualitative research which “...is typically used to answer questions about the complex nature of phenomena, often with describing and understanding this phenomenon from the participant’s point of view. The qualitative approach is also referred to as the interpretative, constructivist or postpositive approach.”(Leedy, P.D. & Ormrod, J.E. 2005.p94.)

Research Design	Data Collection	Nature of data	Data analysis
<ul style="list-style-type: none"> <li>• Collective case studies, to understand a particular situation</li> </ul>	Appropriate written documents, such as books and published articles in well known journals.	Qualitative data	Organization and categorization of terms in common themes. Synthesis into an overall portrait of the case
<ul style="list-style-type: none"> <li>• Content analysis, to identify specific characteristics of the site.</li> </ul>	Visual observation, interviews and written articles in published journals and books.	Quantitative and qualitative data	Descriptive or inferential analysis.

Fig. 1.11 Research method.

The dissertation will:

- Evaluate historical and contemporary design and urban theories through a critical theoretical review.
- Investigate the site and its problems within its context through analyses and visual observation.
- Analyse local and international precedent studies to establish how they have contributed to the recovering and/or integration of urban spaces and landscapes
- Investigate design principles, by critically reviewing precedents and contemporary theory.
- Apply the design principles by designing a site framework as well as a detail site design.

### Validity and reliability

A wide variety of approaches are used to support the validity of the findings. The situation is described in rich detail so that the reader can draw his own conclusions from the data presented. I seek regular feedback from lecturers and professors who have expertise in this specific field of study.

### The significance of the study

The execution of the study is important as this is a new approach towards spatial integration for the University of Pretoria. This intervention can be viewed as a model for future students and designers.

## Methodology

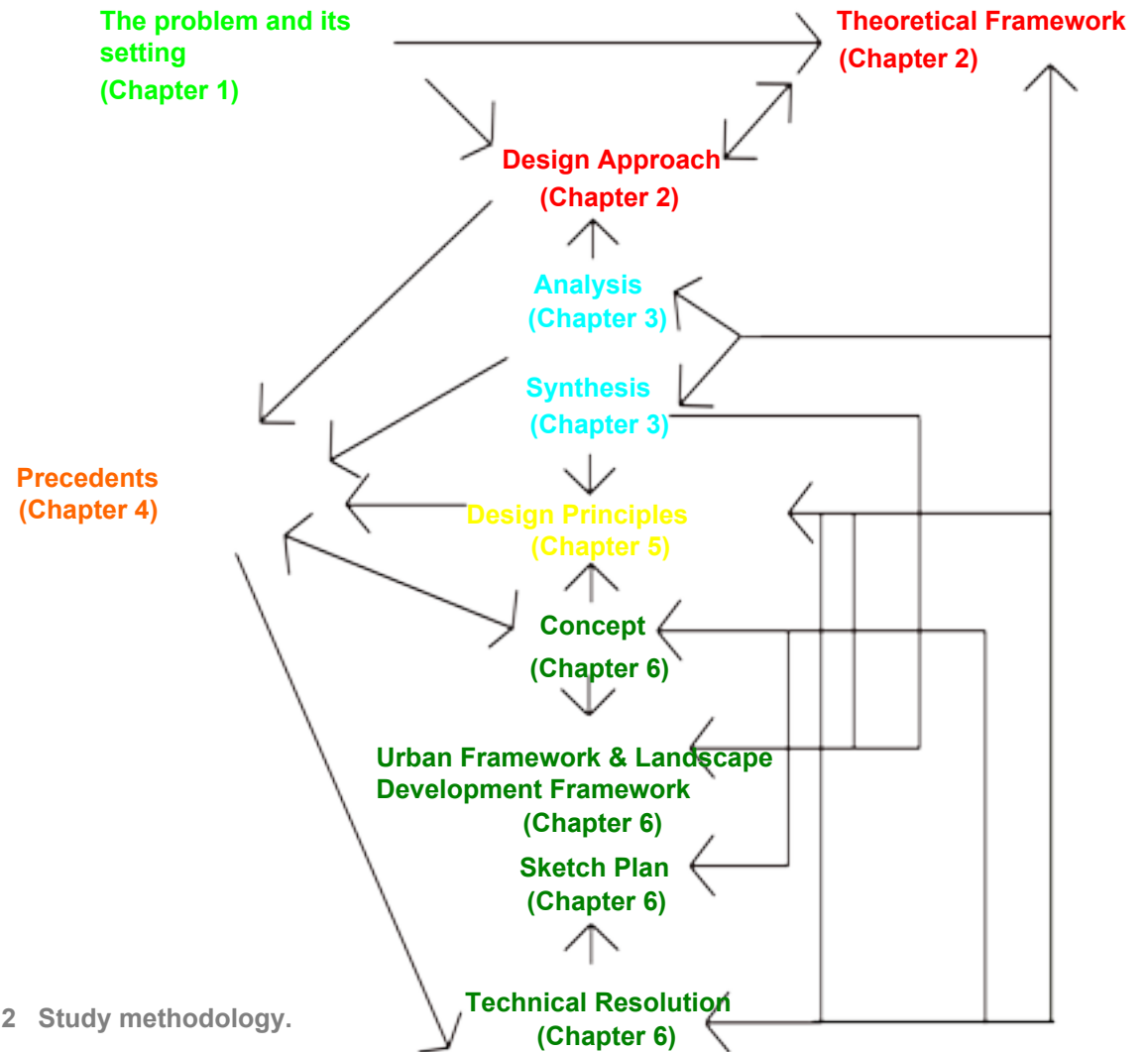

Fig. 1.12 Study methodology.



CHAPTER 2  
THEORETICAL FRAMEWORK

## CHAPTER 2 THEORETICAL FRAMEWORK

This study is undertaken to form a normative design approach, the study is important as it provides a theoretical context on which decisions will be based.

I will divided the study as follows

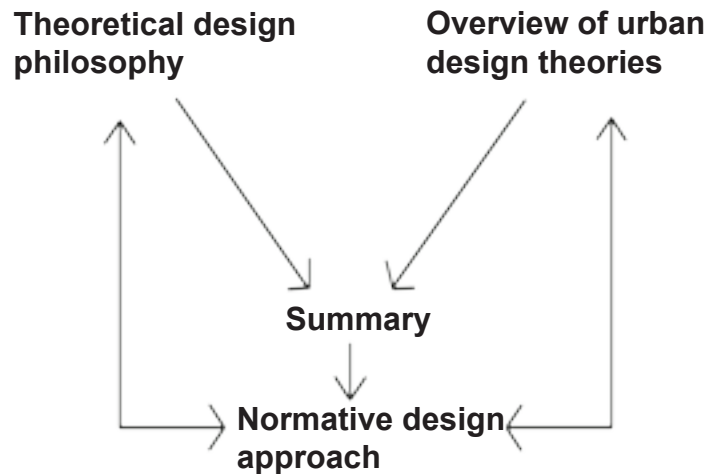

Fig. 2.1 Division of study.

### Theoretical design philosophy

#### Introduction

Humans are not the inheritors of the earth, but borrowers from future generations (Royal Commission on the Future of the Waterfront. 1992.). "In shaping the places where we live, we shape the patterns of our own behaviour." (Lyle, J.T. 1994, p.ix)

Humans constructed landscape patterns, which have over the past century exclude relationships between nature, the earth and humans.

A change in these patterns is needed. This change does not only mean changing our behaviour but also a change in the way we alter the environment. For our culture to survive and for the human environment to become regenerative we will have to change some of these patterns.

This change will not be possible in the long term; unless we first alter our lifestyle and start by regenerating our urban ecosystems by keeping them vital (Cerver, F.A. 1996?). This calls for a change from a consumer to a conserver society as well as maintaining life support processes. Maintaining does not refer to preserve, but rather change in the landscapes which are able to adapt to human purposes. (Lyle, J.T. 1994.) What is needed is redesign. Design in this sense means conceiving and shaping complex systems. "We have to regain of our means of supporting life, we have to embrace them, celebrate them and design is one of the major means." (Lyle, J.T. 1994. px.)

#### Degenerative patterns and linear flows

Human initiatives have replaced multiple networks of unique places and nature's cycling and recycling of materials with rather simple forms and monotonous, bold processes, with constant regularity over the surface of the earth. Apparent throughout the 20<sup>th</sup> century, consumption, the through put of the one way flows became concentrated in large cities, demanding ever increasing volumes of material from the sources.

Lyle refers to James Lovelock (1988) who envisioned the earth, in his Gaia hypothesis, as a self regulating living organism, over the last two centuries industrial technology imposed the one way throughput machine system upon Gaia. The one way through put system operates as a linear time frame with a rising curve. Ultimately this system will destroy the landscape on which it

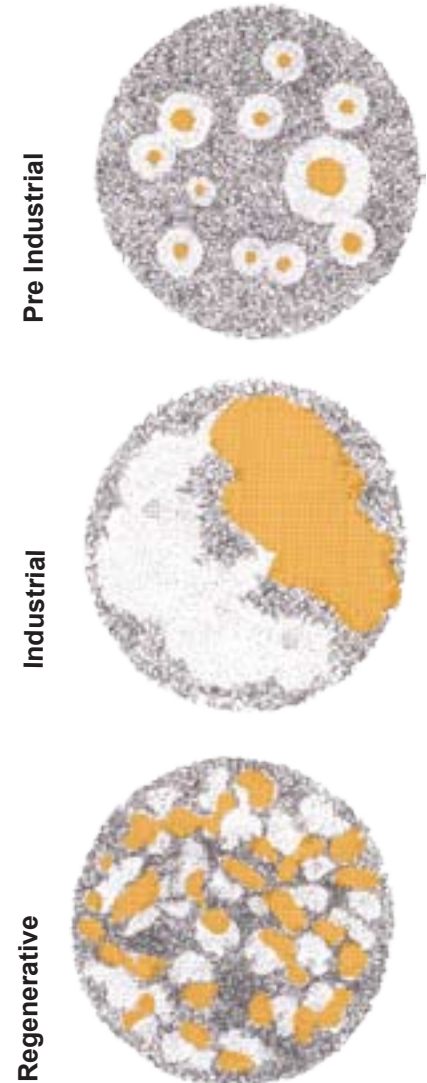

Fig. 2.2 Evolution of land use patterns.



depends. The blending of stability and change – sustainability and development will require approaches different from those of the last two centuries. (Lyle, J.T.1994.)

Inadequacy of palliatives.

There have been, so called palliative approaches, which were based on merely alleviating the problem of degenerative methods. After the Industrial Revolution, Landscape Architects were designing urban parks in order for people to get away from the city. The use of landscapes was promoted as a means of response to the environmental and social degradation. Landscapes were valued and seen as a short term hide away from urban congestion and pollution. (Berger, A.2006.)

These parks functioned as oasis's devoided from city life; they were seen as mere objects which didn't form any relationship between the user and the place and between the building and the landscape.

Environmentalism has grown from a defined interest towards a general concern in most scientific fields, including the profession of Landscape Architecture. The focus was placed on forms and spaces which were designed in order to express ecological principle and environmental values to the greater society. (Meyer, E.K.2000) The ecological approach, by designers such as McHarg was an important era in the Landscape Architectural profession. This method neglected the design of the urban environment and the relationship between ecology and design. (Spirn, A.W.2002.)

The palliative approaches taken so far in environmental regulation have not been sufficient to deal with the original structure based on one way flows. The problem seems to lie with our relationship with the environment. Rather than mitigating impacts we should create development and formulate approaches which work in harmony with nature, by recognizing that humans are part of the environment like any other specie. (Lyle, J.T.1994.)

Designing regenerative systems

“Regenerative design means replacing the present linear system of throughput flows with cyclical flows at sources, consumption centres and sinks.” (Lyle, J.T.1994.p10)

Regenerative systems are not limited to environmental/ecological issues individually. It should be taken further to broaden the concept of landscape materiality to also discuss its phenomenological immateriality. The immateriality is represented for their poetic/symbolic performances and their informative

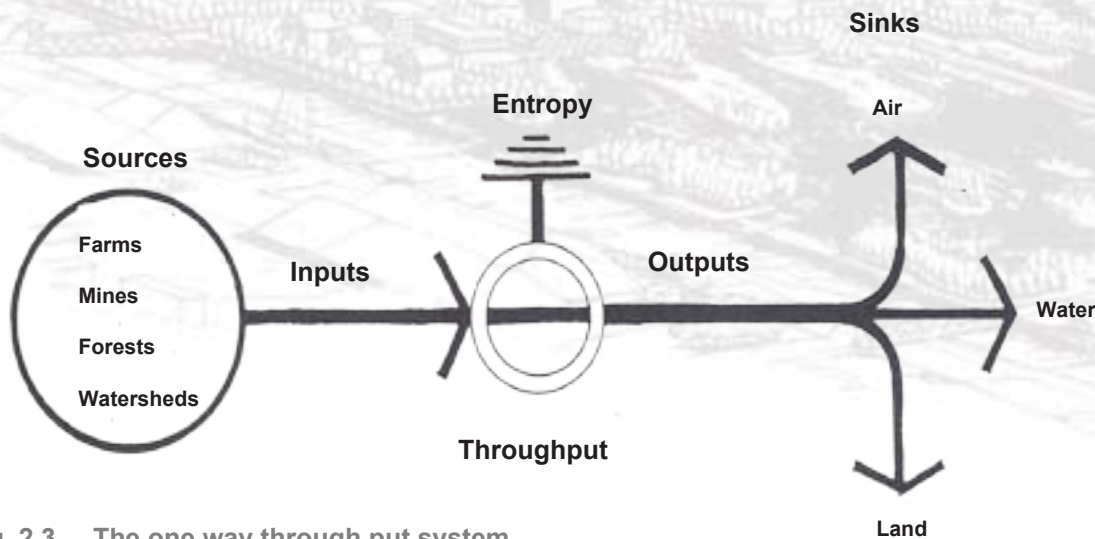

Fig. 2.3 The one way through put system.

engagement. The “materiality” can be divided according to four beliefs, the first recognise landscape as a medium which employs living materials operating within the realm of natural systems. The second belief imagines landscape as an ever changing motion picture film, rather than a motionless framed image. The third argues that if landscape is in continuous fluctuation and instability it must be conceived as interdependent systems and the fourth principle points out the association between nature and technology (Margolis, L & Robinson, A.2007.). Michael Hough further stress this concept by arguing that design should be focused on the notion of change and the opportunities which change provides. The change should be purposeful and beneficial with ecology and people as essential foundation. (Hough, M.2004.)

### Aesthetics

” The domain of aesthetics must come to be seen as coextensive with the ecosphere , rather than narrowed down to its traditional applications in art criticism , so that aesthetic values may no longer be isolated from ecological ones.” (Meyer, E.K.2000.p195.)

Together with the understanding of the processes of natural systems, equally, landscape aesthetics plays a significant role in the design of regenerative systems. Aesthetics should be used as a vehicle to emphasise and identify regenerative landscapes.

The Village of Yorkville Park acts as a unique inner – city ecological opportunity for the introduction and aesthetical display of native plant species.

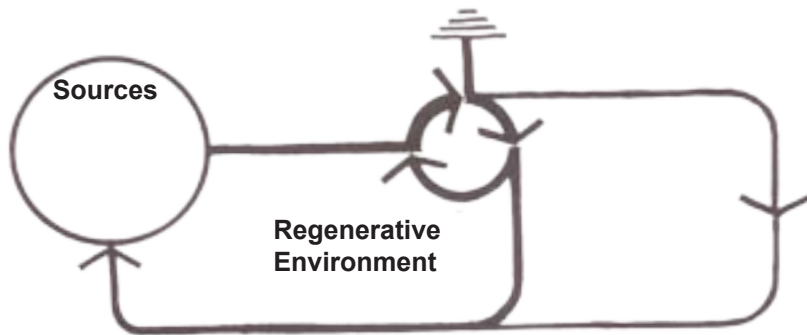

Fig. 2.4 The regenerative flow.

When designing regenerative systems Landscape Architects should refer to ecology less for methods of description and prescription and more for its ideational, figurative and substantial implications. Some ecological designs have not accommodated for human needs for order, meaning and beauty. (Woodward, J.H.1997.Signature based Landscape Design) Aesthetics and technology should be taken into the realm of ecological design to create order, meaning and beauty.



Fig. 2.5 The village of Yorkville Park.

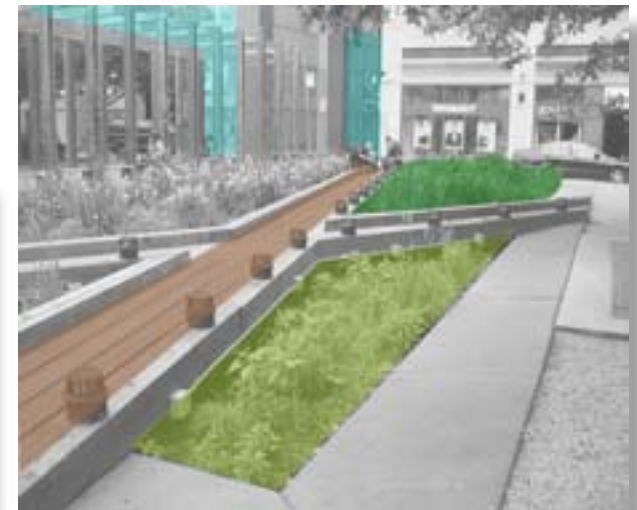

Fig. 2.6 The village of Yorkville Park.



Fig. 2.7 The village of Yorkville Park.

- Giving form to the formless

In the 1980's the question raised by designers : *"How could one give form to dynamic processes and fluctuating systems but not resort to the modern design codes that privileged static, bounded , ideal objects in art and architecture and often regulated landscape to visual scenery, a stripped – down version of the pastoral (Meyer, E. K.2000.p189).* Landscape Architecture should give form to the interplay of dynamic processes. Every landscape, regardless of scale, should be responsive to all the interactive systems.

- Solving ecological problems

Ecological and environmental issues should be seen as cultural as well as scientific concerns. The challenge lies in designing landscapes which initiate an aesthetic experience and reduce the barriers between humans and the natural world (Meyer, E.K.2000.). Landscape Architects have the ability to encourage a land ethic and an aesthetic based on a continuum between human nature and non - human nature (Meyer, E.K. 1997.).

- Enhancing the human experience

This approach of enhancing the human experience expanded ecological design to include the aesthetics. The phenomenology of landscape design taps into the concrete experience of place. If these processes are able to merge cyclical processes with social life, then this type of design can redefine what it means, as humans, to be part of the environment.

The landscape should create the awareness that ecology flows through human life and constructions. This awareness can be established through an aesthetic experience that enhances the feeling that nature's rhythm overlap with the daily routine. (Spirn, A.W.1984.)

The aesthetics of the experience can be signified by employing materials and processes of nature. This experience can be even more enhanced by the constant modification of the landscape, through people and natural processes. (Meyer, E.K.2000.)

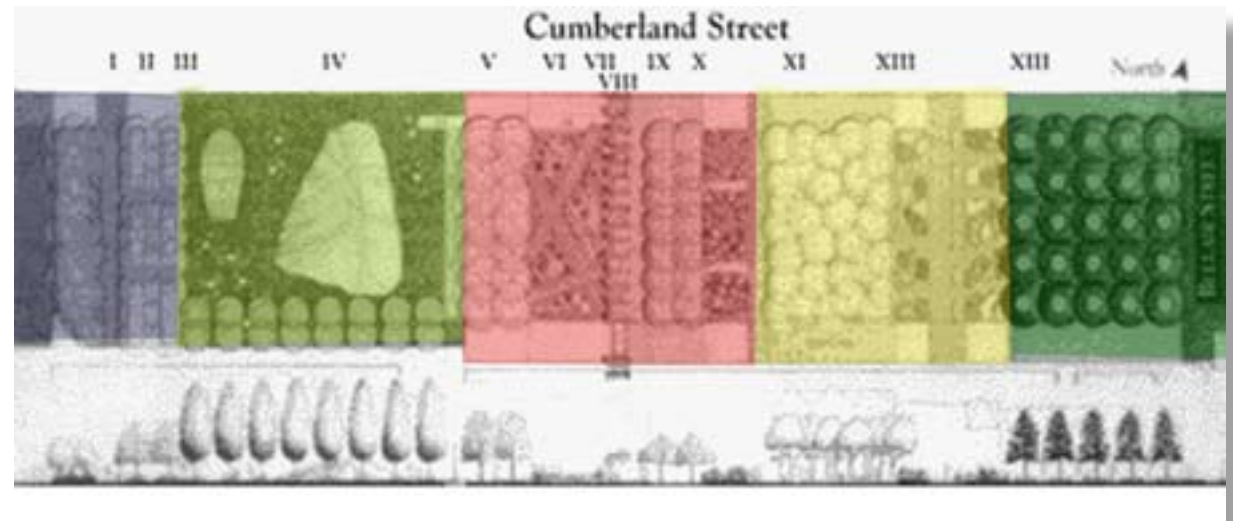

Fig. 2.8 Yorkville Park, sectional vegetation display.

*The crux of the aesthetic challenge lies in: "How to give form to the marvellously unique conspiring of people and place of elements and systems of history and happenings. " (Zanzot, J.1997.)* Thus ecosystem in an aesthetic sense should be a powerful experience which can be enhanced through the application of appropriate technology.

#### A different kind of technology

Regenerative systems should play an important role in global renewal, since these systems work in continuous interaction with both people and natural systems; they require natural as well as scientific information. Solving the environmental and resource dilemma is not depended on technology, but the relationship of humans with the environment is the central issue. It is important to realise that technology is an expression of that relationship; our survival will depend on how we apply technology in the future. For future development technology should therefore be based on natural processes. (Hough, M.2004.)

#### Dilemma of Development

The dilemma is that development provides for habitat and sustenance, but development inevitably alters our environment. We can either adopt the view *"that humans have no right to wreak such devastation on a natural community purely for human interests ..."* (Lyle, J.T.1994. p20) this view has been expressed in environmental literature since the 1960's. On the contrary, we can argue that humans are an essential part of the environment and by developing the land for human purposes is not qualitatively different than changes made by other species.

The former view is purely that of preservationists and is challenged by the enormous amount of people living on earth. The latter view raises the issue that development of humans and that of other species are critically different. Technology is the all important difference and as mentioned previously, the past

two centuries development patterns and concepts of nature are indications of this. (Lyle, J.T.1994.)

The concept of viewing humans and nature as separate entities has filtered through to building, planning and design. The resolution of these must be found in an ecosystemic view which includes the whole urban environment.

#### Ecosystemic Approach

In his essay *"Human ecosystems"* Lyle brings forward the concept of landscape as ecosystem. (Lyle, J.T.1985.) Ecosystems are evolving entities which regulate the development of the species. The species present in any environment forms consistent, but complex and not entirely predictable sets of interactions. Thus they form an ecosystem where, in urban areas, human ecosystems are the ordering systems of life. (Lyle, J.T.1994.) These human ecosystems embodies ecological forms, they consists out of the cultural, emotional and physical realm. Landscapes like these have deep form which is shaped by interactions of inert processes and human vision. Deep forms are a meeting of form, truth, psychology and nature, art and science. (Lyle, J.T.1991 *Can Floating Seeds make Deep forms?*)

By clarifying complex systems of relationships involved in natural processes, the ecosystem concept establishes a theoretical framework for regenerative life support principles.

To form an ecosystem approach it is essential to understand that its primary concern is with the interactions amongst parts, which consists out of the continuous evolving culture, technology as well as the natural world. Together they form relationships which should be utilised in the shaping of spaces. The regenerative landscape should not be pre conceived it needs to have the ability to creatively form frameworks which can change interconnect and reinforce each other. For any design to be regenerative, the supply system of materials and

energy must be continually self renewing. (Lyle, J.T. 1994.)

Thus, an ecosystem approach:

- Includes the system as a whole
- Focuses on the interrelationships among the elements
- Understands that humans are an integral part of nature.
- Identify the dynamic nature of an ecosystem which is similar to a moving picture

## Overview of urban design theories

It is important to study traditional urban design theories to see which are applicable and how they can be used in the development framework.

### Traditional urban design

After studying various urban design principles from Lynch, Trancik and Bentley et al, it is clear that urban design is an integrated process which, when correctly applied, enhances the overall legibility and cultural fit. These theories are mostly focused on the visual, social and cultural realm of the urban environment but show a lack in giving guidance to ecological regenerative principles within the urban environment.

### Urban Ecology

In his book, City and Natural Process Michael Hough argues for using urban ecology as a basis for shaping our cities. The city is a constant process which evolves, which depends on life processes and the inter connectedness of the living and the non - living environment. (Hough, M.2004.) Thus the great challenge of urban ecology lies in the design process, a process which should form visible links between urbanism and ecology on a variety of scales. The

problem with holistic ecosystems is demonstrated in cities as the ecosystem city is not self regulated but regulated by humans. (Rebele, F. 1994.)

### Summary

Through this we can come to the conclusion that the landscape should function as an ecosystem, stitching connections between people, technology and the landscape. (Lyle, J.T. 1994.) The task of implementing an ecological view of cities has only recently emerged. If there is such an urge for incorporating ecology into the urban environment and the concept of "urban ecology" is emerging as a highly valued part of present day urban design, then why haven't regenerative ecological urban principles not yet been formulated?

Although traditional urban theories and principles have not addressed or considered the function and the interdependence of ecology, they should still be used as an important element in any urban design project. There is a gap in urban design theories, a gap which needs to be fulfilled by incorporating regenerative urban design principles which supports the view of the city as an ecosystem. What they would mean, how they should function, what they should do has all been clarified. They should just be formulated and applied. These principles will be translated to form the essence of the theoretical philosophy. (Refer to Chapter 5)

### Normative design approach

The influence of the designer cannot be concealed and the human origins cannot be ignored. Sustainable landscapes are signified to have a higher level of complexity than cosmetic landscapes. The intricate ecological relationships are sometimes hard to preserve, therefore it is important to give them conspicuous expression and visible interpretation.



*“The hand of the designer can be as heavy on the land as a highway interchange or a strip mine. Ask whether that influence is destructive or sustainable is it to trivialize the complexity of relations between humans and the rest of the world.” (Thompson, J.W & Sorvig, K. 2000.p18)*



# CHAPTER 3

## CONTEXT STUDY

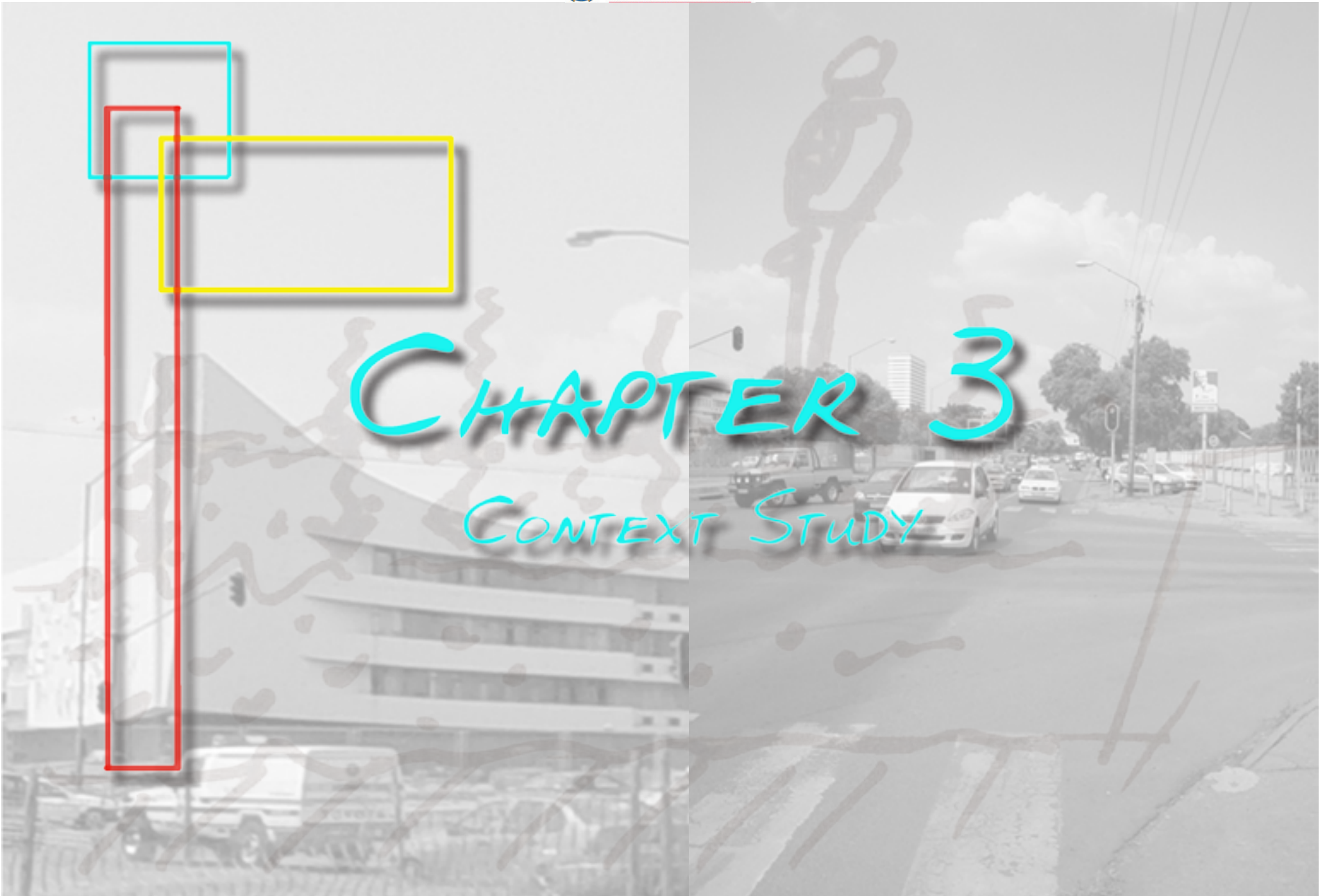

## CHAPTER 3 CONTEX STUDY

### Introduction

No ecological system can be studied in isolation from the environment in which it exists. Therefore the context study will be divided into three different scales.

- Urban scale  
The site and how it functions in relation to Tshwane
- Precinct scale  
The site and its relation with its immediate surrounds
- Site scale  
A detail analysis of the activities and uses on the site

The focus must be reduced and enlarged to consider the impact on various scales. The issues under investigation will be seen as different systems operating on various scales in, and within the context of the site. This method will enable the designer to draw as much potential from the site and assess which systems might be of real significance for the future design.

Other studies will include a historical, social and physical environment analysis.

### Historical Analysis

“When we describe the forms and features of a landscape, we are actually observing the artefacts and fingerprints of the formative processes.” (Woodward, J. 1997.) Without underestimating the importance of functional analysis, the landscape architectural reading of sites is not limited to quantities and capacities. A historical analysis is conducted to see the landscape as a palimpsest and to understand the time layers of the site, knowing how the non-physical environment on the site as well as the surrounding context affected the

development of the site.

“No place is a tabula rasa, without history; any intervention by any designer is part of a series of interventions, of marks already inscribed or yet to be inscribed on the site. Every design is subject to the actions of dynamic and unpredictable natural and cultural forces—the continual transformations produced by growth and decay, for example, or by changing patterns of social use and habitation.” (Beardsley, J. 2000.)

#### Site specific

The form of the site is a constant evolutionary process. Originally the site formed part of the farm Elandspoot. The farm Elandspoot was divided in two by an ox wagon trail running from east to west – currently known as Lynnwood Road. (*Africana Collection 1900's*) When Boys High was established in 1901 it formed part of their sports fields, (*Pretoria Boys High. 2000*). In 1930 it was sold to the CSIR (Council for Scientific and Industrial Research). The site was known as the Petroleum Research Institute and later as the CSIR's Division for Energy and Technology.



Fig. 3.1 Existing Historical buildings.



Fig. 3.2 1930 Site buildings.



Fig. 3.3 1940 Site buildings.



Previous site activities included:

The study and investigation of fuel resources in South Africa  
Testing, analysing and grading of coal products  
Coal grading,  
Physical and chemical surveys of coal  
Coal washability, crushing and screening  
Coal segregation and degradation

The Fuel Research Institute was formerly established in 1931 and the first offices were constructed in 1932, these early 1930's red brick buildings are typical examples of Public Works buildings of that era. In 1969 the briquette factories was established and in 1976 extensions were made to the dense medium coal washing facilities.  
(CSIR. 1980)

The buildings on the terrain were owned by the state. On the 1<sup>st</sup> of February 1989 the University of Pretoria laid down a proposal to make it part of the Main Campus and on the 4<sup>th</sup> of October 1990 this proposal was confirmed with the Department of Education and Culture.

The site was transferred to the University on the following behalf:

- That the site is available to the University only for educational reasons
- The university should be responsible for moving costs of any property of the CSIR and the DET.

(Ad Destinatum. 1982 - 1992)

After a few renovations and internal structural modifications on some of the buildings they were allocated to various departments which used them either for storage, administration offices or lecture facilities. Other activities included a kiosk and a Centre for Electromagnetic Studies.

#### Contextual

A natural stream used to run through the existing sport fields, it was canalised after numerous incidents of flooding were experienced after heavy rains. The channel has a trapezoidal profile with no formal lining. This has a result that the maximum channel depth has increased, due to scouring and erosion. (Presently 2m below the existing ground level.)

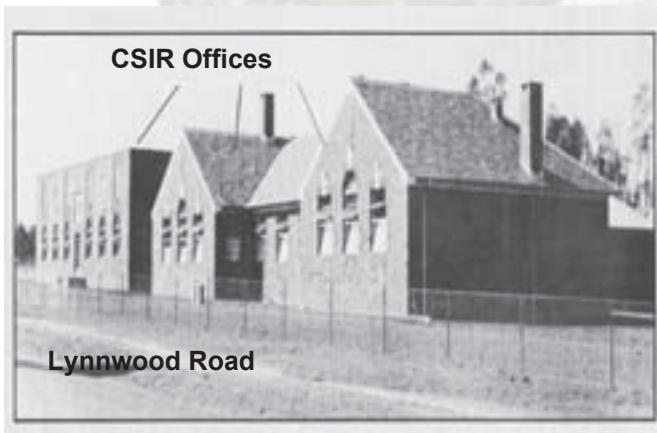

Fig.3.5 1960 Birds Eye view of CSIR offices.



Fig.3.4 1933 CSIR offices.

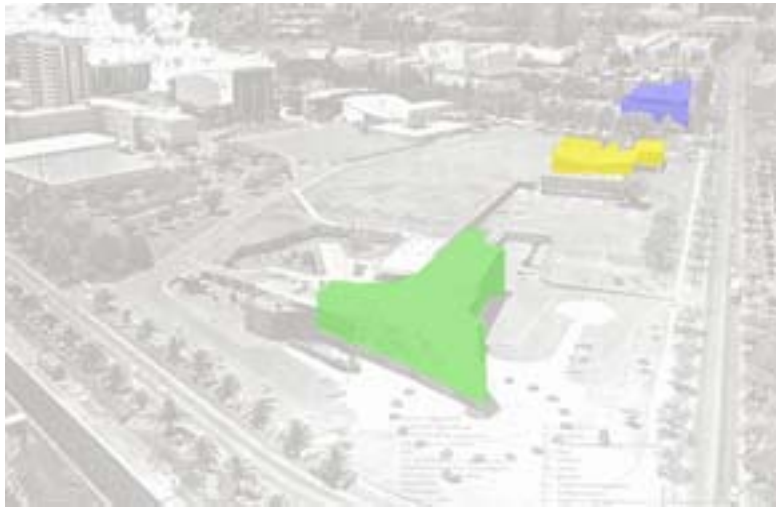

Fig.3.6 Adjacent site buildings.

The buildings lying towards the north of the site, next to Lynnwood Road

**Administration Building** (Brian Sandrock)

The construction of the Administration building started in 1960. The building was designed to face directly to the Voortrekker Monument. During 1979 – 1982 renovations were done.

**Boukonde Building** (designed by own personnel)

The Boukonde building was constructed in 1960.

**Fine Arts Building**

The Fine Arts building was constructed during 1948.

(Hindes, C.2003.)

**The Footbridge and Lynnwood Road**

Lynnwood Road was widened in 1990 and the footbridge across Lynnwood was constructed in 1995, after a student was killed while crossing the road.

(Potgieter, D.2008)

**Urban scale**

Study Area

Park Street, including the Gautrain station and Duncan Street will respectively form the northern and eastern borders for the area under investigation. The boundary line of Pretoria Boys High will form the southern border and Walton Jameson Avenue, next to Afrikaans Meisies Hoër, the western boundary line.



Fig. 3.7 Study Area.

Based on research and evolution of modern space and the analysis of historic precedents, the following approaches to urban design theory can be identified. An integration of these theories can improve the success of urban design.

- Figure ground

The figure ground drawing is a graphic tool for illustrating mass void relationships, which clarifies the structure of the urban environment. The articulation of solids and voids establish the physical sequences, visual orientation and distinctive characteristics between places.

This is the starting point for an understanding of urban form and is the analysis of relationships between building form and open space.

#### Land uses

The sport grounds surrounding the educational precinct, lends the area a more rural character in terms of open space. Towards the north, composition of land use around the university is very diverse and accommodates a range of activities. Commercial and retail facilities have been introduced over the past 10 years; it forms the centre of the area, consisting of Hatfield Plaza and Hatfield Square as well as some buildings along Burnett Street.

Towards the north, residential areas with the highest concentration are situated at Hatfield Village and south of Prospect Street, including student accommodation. Office blocks are found in high concentration along Duncan Road, especially along the proposed Gautrain Hatfield station. Newly developed office and houses which have been converted, form part of this mixed use area.

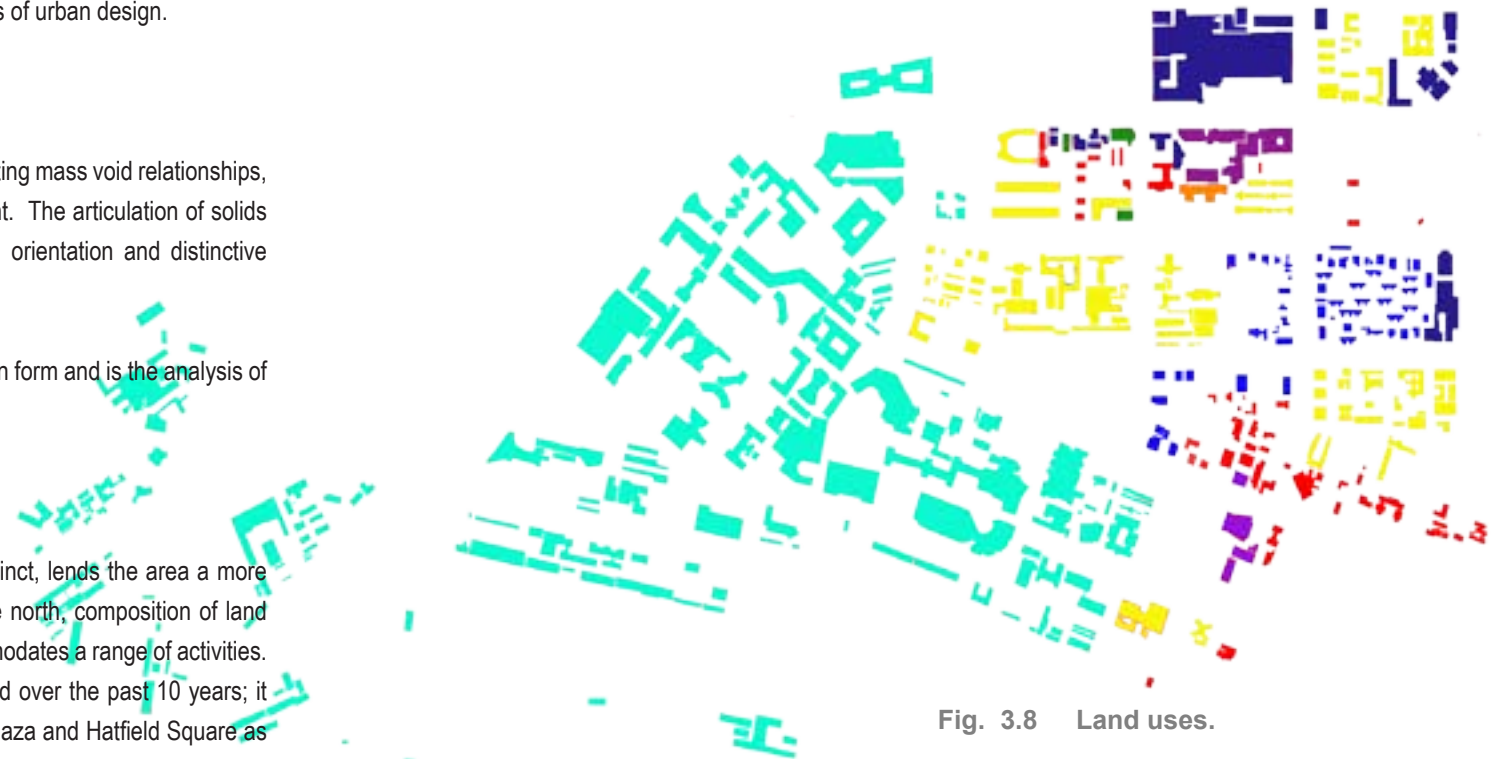

Fig. 3.8 Land uses.





Fig. 3.9 Ground Figure.

- Linkage

In this theory, the dynamics of circulation becomes the generator for urban form. The organization of lines connects the different parts of the urban network.

Visual orientation

Tukkielaan forms a strong pedestrian axis along the north south direction and Lynnwood Road forms a strong axis along the east west direction.

Edges of buildings

Building edges along South Campus are situated a significant distance from Lynnwood Road, this results in lost space between building edges and Lynnwood Road.

Transport routes and modes

Vehicular system

Current vehicular activity is primarily along Lynnwood Road. Lynnwood Road forms an east – west vehicular access route between the East and the CBD. Duncan Road forms the most important road in the north south direction as it links the Hatfield node with the Brooklyn node and serves the area north of Hatfield via Gordon Road. Due to the position of the University of Pretoria, there is a lack of routes in these directions.



Fig. 3.10 Visual orientation.

Fig. 3.11 Building edges from Lynnwood Road.



Offset of building edges from Lynnwood Road

The Tshwane Development Framework proposes for Lynnwood Road to become an activity spine with vibrant activities concentrated along specific portions of the road. Where appropriate traffic calming measures will be implemented to create a pedestrian and cyclist orientated environment. (<http://www.tshwane.gov.za>) Local access considerations and urban design should be taken into account along Lynnwood Road. The introduction of service roads should also be considered.

Public Transport plays an important role along Lynnwood Road. Several bus and taxi stops are situated along Lynnwood Road. A future BRT (Bus Rapid Transport) stop on the corner of Lynnwood and University Road will be completed in 2009. (Claassen, C. 2008.) (Refer to appendix 2)

#### Railway system

The Hatfield Gautrain station is within walking distance from the University of Pretoria, this provides easy access for students from Johannesburg. Other train stations in close proximity from the site include the Hartebeespoort station in Hatfield and the Loftus station next to University Road.

- Place

The essence of place theory lies in the understanding of cultural, social, environmental and human characteristics of a physical place. (Trancki, R. 1986.)

According to the Tshwane Regional Spatial Development framework various urban core activity nodes are identified within the city of Tshwane. Urban cores are activity nodes of metropolitan significance which are characterised by high intensity mixed land use, high levels of accessibility, 24 hour activity, well defined public spaces, pedestrian friendly environments and public transport facilities and activities. It forms a hub for various levels of education, research, business,

sports and tourism. These activities are clustered around strategic points in the city. The site is located in an educational cluster situated in the Central Western Region of Tshwane.

The site is centrally located and forms part of the transition zone between two nodes of activity; namely the Brooklyn and Hatfield Metropolitan Cores. Brooklyn has developed into a major financial centre and proposed to be densified and extended to the north, Hatfield as an existing node will accommodate the future Gautrain Station.

(<http://www.tshwane.gov.za>.)



Fig. 3.12 Bus routes.

The understanding of environment places a large focus on the recognition that human life forms the central part of the physical and cultural medium. Lynch looked at the city as a system that contains a set of organizing structures which have physiological significance for its inhabitants. (Trancki, R.1986.) He outlined a vocabulary for reading and interpreting a place through different constructions, he provided one of the first theoretical strategies to connect the aesthetic and the environment. (Meyer, E.K.2000.)

The contents of the urban environment, which formulate the physical structure give spatial definition and help create a sense of place. It is important to identify these different elements, in order to understand the urban site and how it connects to its surroundings. (Trancki, R.1986.)

#### Districts

The isolated buildings of South Campus are not tied into the larger context, this becomes visible when analysed through the figure ground.

#### Social composition

People between the ages of 15 and 34 make up the largest composition of residents in the Hatfield-Brooklyn area. A large percentage of these people are students who only stay in the area for 3 – 4 years. Brooklyn, the neighbourhood lying east of the site is home to more permanent residents. (Census 2003)



Fig. 3.13 Site within educational cluster.



Fig.3.14 Spatial elements of the city.

- Urban green and hydrology

### Urban green

The site is surrounded by a large amount of sports fields which form a large percentage of the urban green structure in the area. These green areas in the city are deceiving as they offer no contribution to the overall urban ecological system's vitality and diversity and only function as visual amenities. Various alien species, like Eucalyptus and Casserina are found along the channel. The palm trees along University Road and the Jacaranda trees along Lynnwood Road have historical value and cannot be removed.

### Water bodies

The open storm water channel runs from the Roper street entrance of Pretoria Boys High towards University Road where it forms a closed system which conveys the water to the Walkerspruit channel. As a result of the channel an abundant amount of birdlife and tree species are present along the southern edge of the site. The linearity of the channel and the amount of tree species growing along its edges functions as an urban green corridor, enabling the movement of various species.

Fig. 3.15 Districts.



Fig. 3.16 Green areas and water bodies.



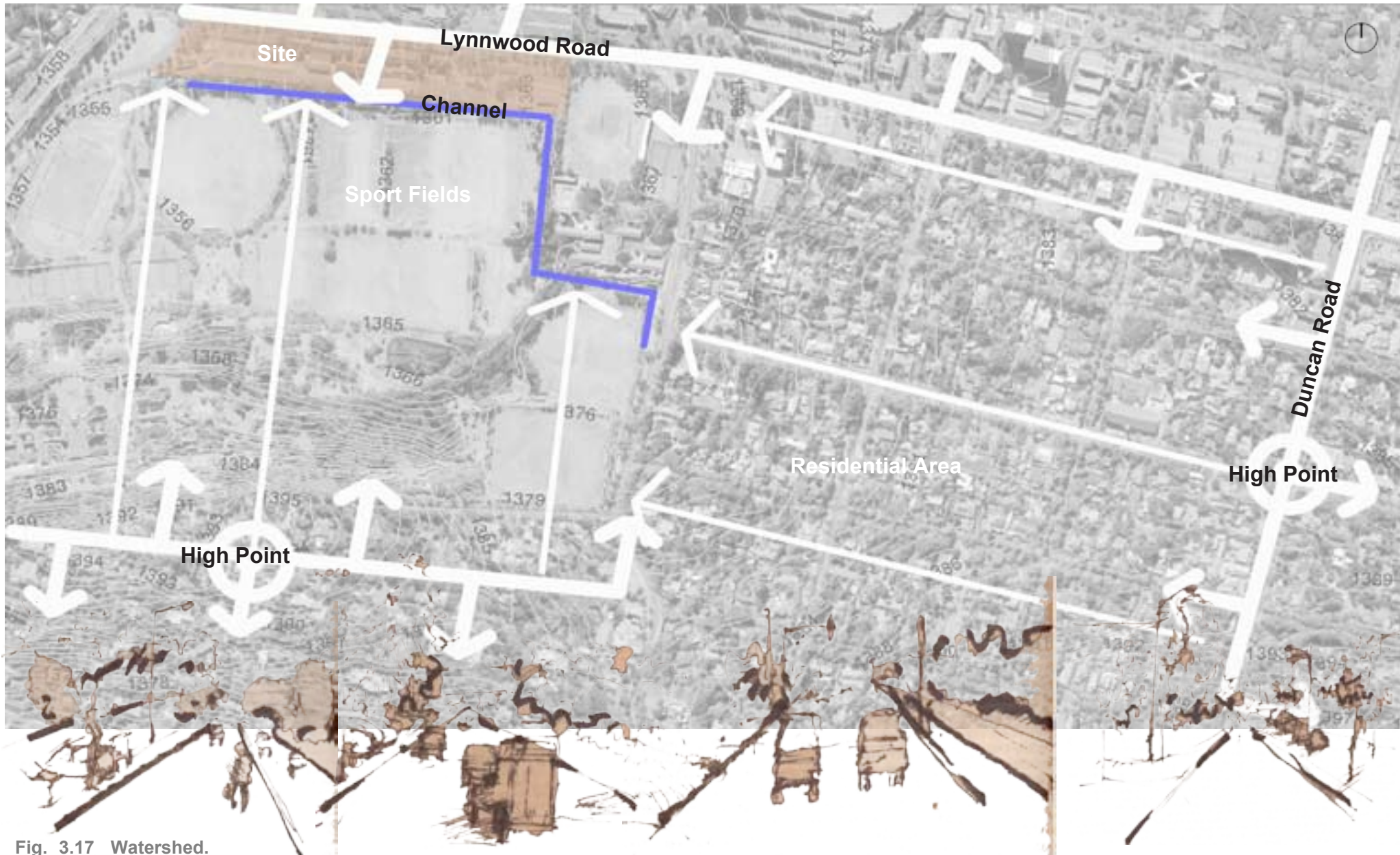

Fig. 3.17 Watershed.

Fig. 3.18 – 3.21 Vignettes along Lynnwood Road.

## Precinct scale

The systems operating on site level are generated by existing systems which operate on a bigger scale. Although the site has its own rhythm and character, the surrounding context plays a major role in the continuous flow of systems operating on the site. The precinct analysis is conducted to have an understanding of the area, its activities, functions and overall character.

Currently Holm and Jordaan Urban designers are formalising a framework for Main Campus. It is still just a proposal and has not yet been approved and published. As a student group, working on or near the borders of Main Campus we have proposed our own framework for the campus and its immediate context. The framework (refer to appendix 1) is based on The Tshwane Spatial Development Framework, the existing framework for Hatfield and the Tshwane Integrated Development Framework. I have also taken into account aspects which were raised during a class meeting with Mr. Jordaan and some proposed future development of South Campus which came under my attention through interviews with Mr. Potgieter from the Facilities and Services division of the University of Pretoria.

The area surrounding the University of Pretoria's Main Campus is changing from a sub urban to a more urban environment. Main Campus is continuously expanding to accommodate for the rapid student growth, walking distances on campus are getting too time consuming resulting in the need to cluster facilities. (Jordaan, G.2008.)

### Study Area

This study is focussed between the crossings of Lynnwood and Roper Street and Lynnwood and University Road. The area on Main Campus, along Lynnwood Road and the Sports fields towards the south and east is also included in this study.

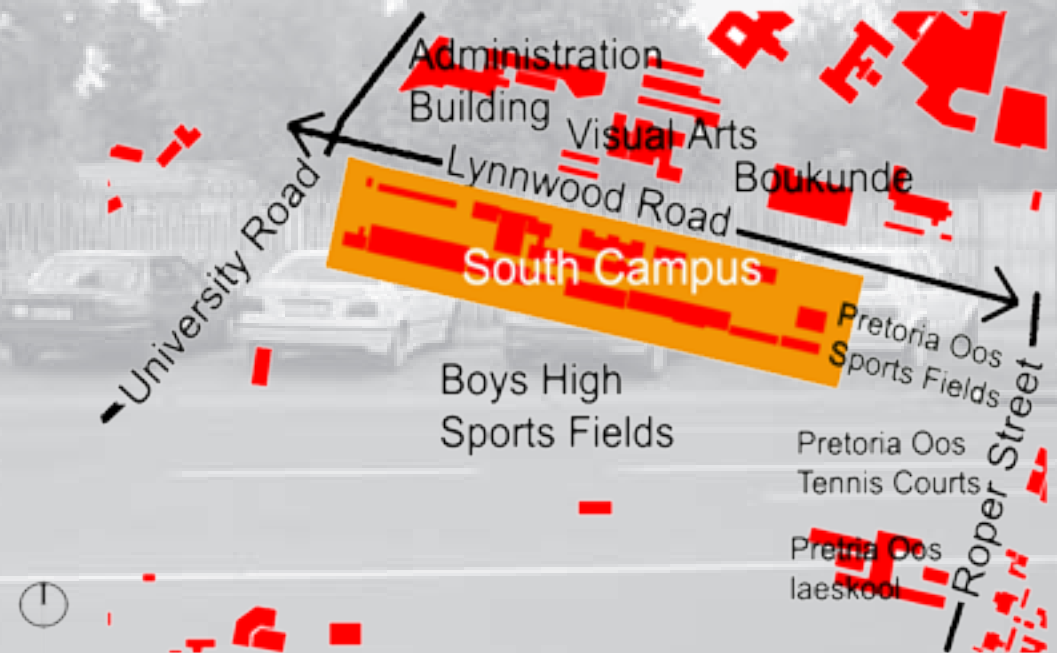

Fig. 3.22 Study Area.

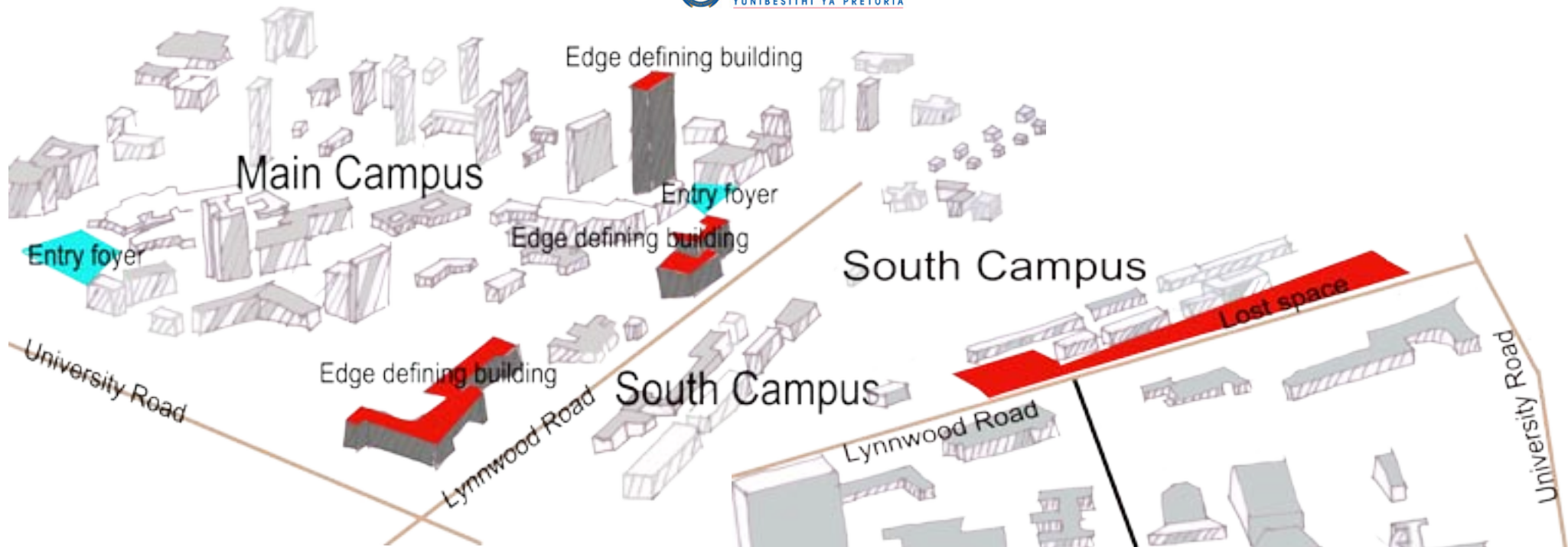

Fig.3.23 Types of urban solids and voids.

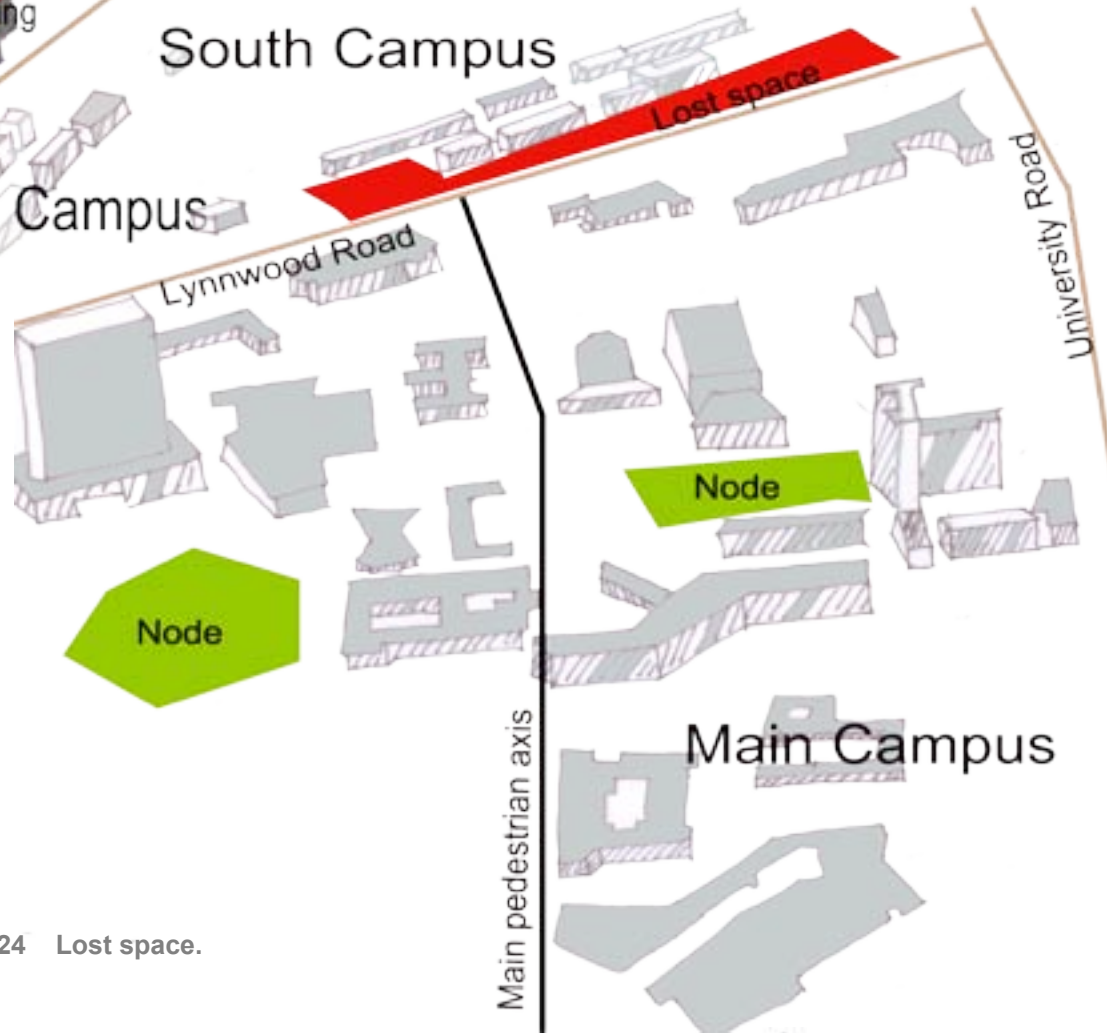
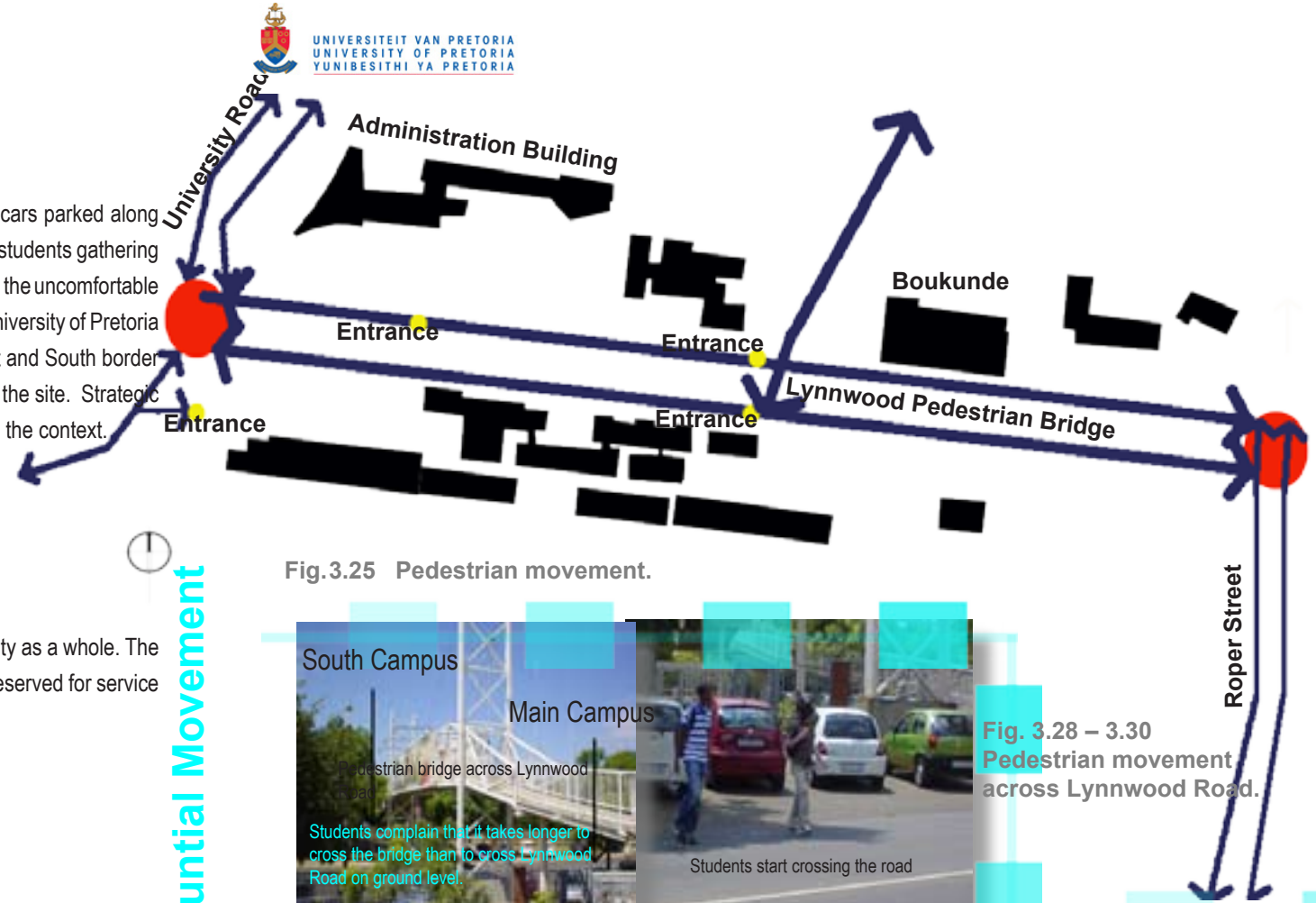

Fig. 3.24 Lost space.

Pedestrian movement

Pedestrian activity streams from the large amount of student cars parked along Lynnwood and University Road as well as school children and students gathering at bus stops. The fast vehicle movement on Lynnwood Road and the uncomfortable pedestrian bridge over it separates the South Campus of the University of Pretoria from the Main Campus. The school sport fields along the East and South border is fenced off and walled off therefore prohibiting infiltration into the site. Strategic planning with regard to movement is of extreme importance to the context.



Vehicular movement

Lynnwood Road

Lynnwood Road acts as a link which connects the site to the city as a whole. The vehicular access gate situated along Lynnwood Road is only reserved for service vehicles.

Sequential Movement

Fig.3.25 Pedestrian movement.

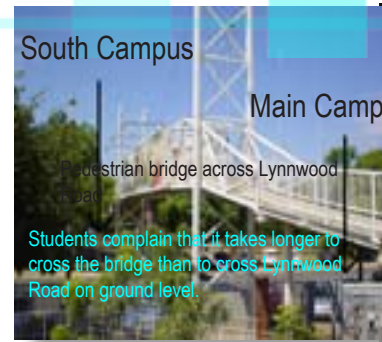

Fig. 3.27 View from Main Campus



Fig. 3.28 – 3.30 Pedestrian movement across Lynnwood Road.



Fig. 3.26 Existing section across Lynnwood Road.

University Road

University Road connects the site to its immediate surroundings. The only vehicle access on University Road, into and from the site, is not functioning. Vehicles entering and exiting the site and vehicles entering and exiting the informal parking results in traffic congestion, especially during peak traffic hours.

Visual Permeability

Visual permeability is prohibited as a result of the palisade fencing and dense plantings along Lynnwood Road. Medium density vegetation and fragmented pieces of solid wall minimize the visual permeability of the site. The edges around the site forms isolating barriers rather than uniting seams, it is turned upon itself and has little reference to the city outside



Fig. 3.37 Vehicular movement and bus stops.



Fig. 3.31 – 3.36 Sequential movement.

Hydrology

Storm water drainage

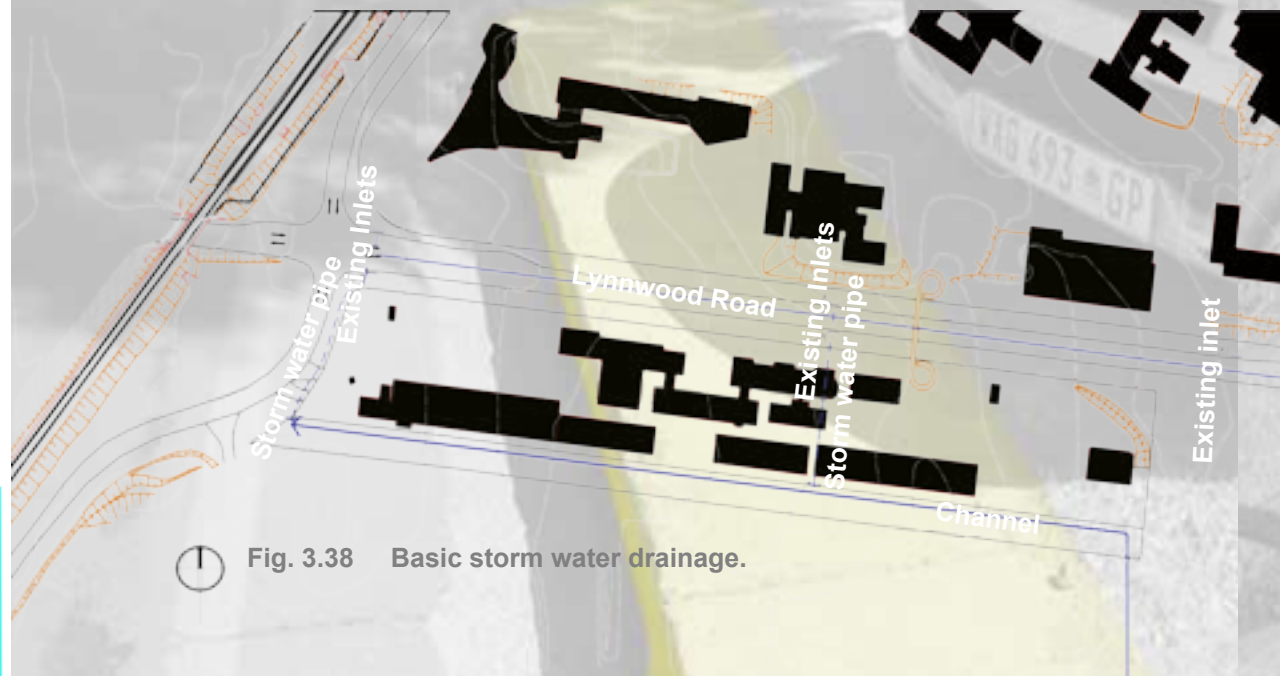

Fig. 3.38 Basic storm water drainage.

The Channel

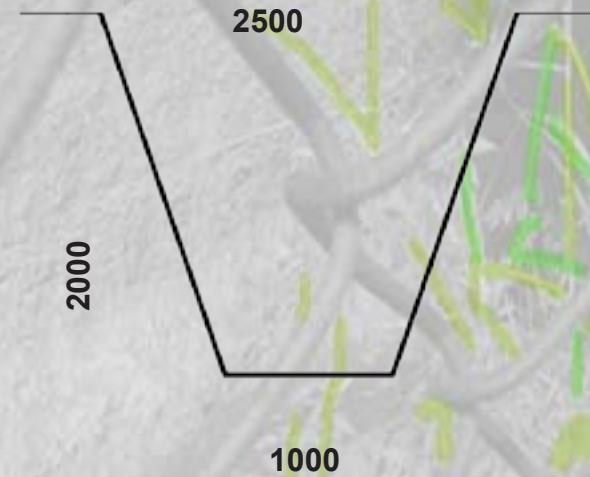

Fig. 3.39 Channel profile and dimensions.

The wetland system at Pretoria Boys High

The wetland system near the main entrance gate of Pretoria Boys High is man made wetland which functions as a natural system. The water depth is maintained from runoff and an overflow sewage pipe. During exceptional dry months water is pumped from a bore hole lying further south. The wetland supports a viable community of fish species and a healthy insect life. Water seeps down from the bottom of the wetland due to the porous nature of the soil found in the area. (Grobelaar, J. 2008.)

### Wildlife

Most wildlife occurs along the strip of trees planted along the channel. The wetland at Pretoria Boys High also acts as a stepping stone for various animal species inhabiting the urban environment.

### Future Developments

New pavilions are proposed on the western side of each sport field at Pretoria Boys High.



## Site scale

By analysing the site on plan it identifies boundaries and shapes, but the spatiality of trees is neither a solid nor a void and therefore and in addition to the two dimensional view, a three dimensional sequence explores the space making opportunities. (Hough, M.2004.)

Rather than reading a space as emptiness, defined by a series of surfaces, an in depth vision sees the open space as a habitat in which the sky and the ground surface engage in multiple relationships.

The ecosystem on the site is fragmented and reduced to mere shreds, buried under refuge, left in neglected corners. This analysis tries to capture the spirit of the site and its main focus is to understand the existing systems operating on a site specific scale. The study zooms in on different detailed areas two dimensionally on plan and three dimensionally, by moving through the site, experiencing it on a human scale.

## Study Area

The chosen site lays 25° south 28° east. It is situated directly south from Main Campus, consisting out of two parts, remainder of portion 332 of the farm Elandsport and portion 375.

## Cadastral information

The site's registered zoning is educational and building lines are 4.5 m from the sides and 3.5m from the street.

(City of Tshwane , City Planning and Regional Services Department.2008.)

## Physical Area of the site

The total site area is 35600m<sup>2</sup>

## Physical sequence

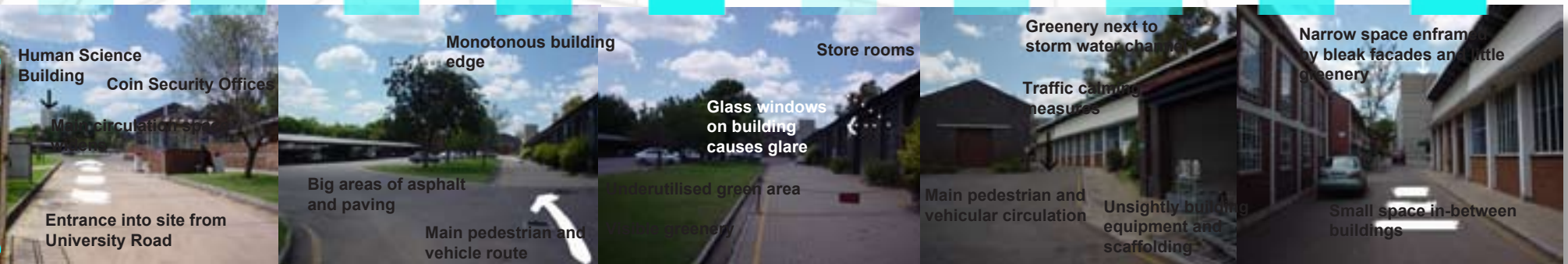

Fig. 3.40 – 3.45 Physical sequence.



Existing site activities

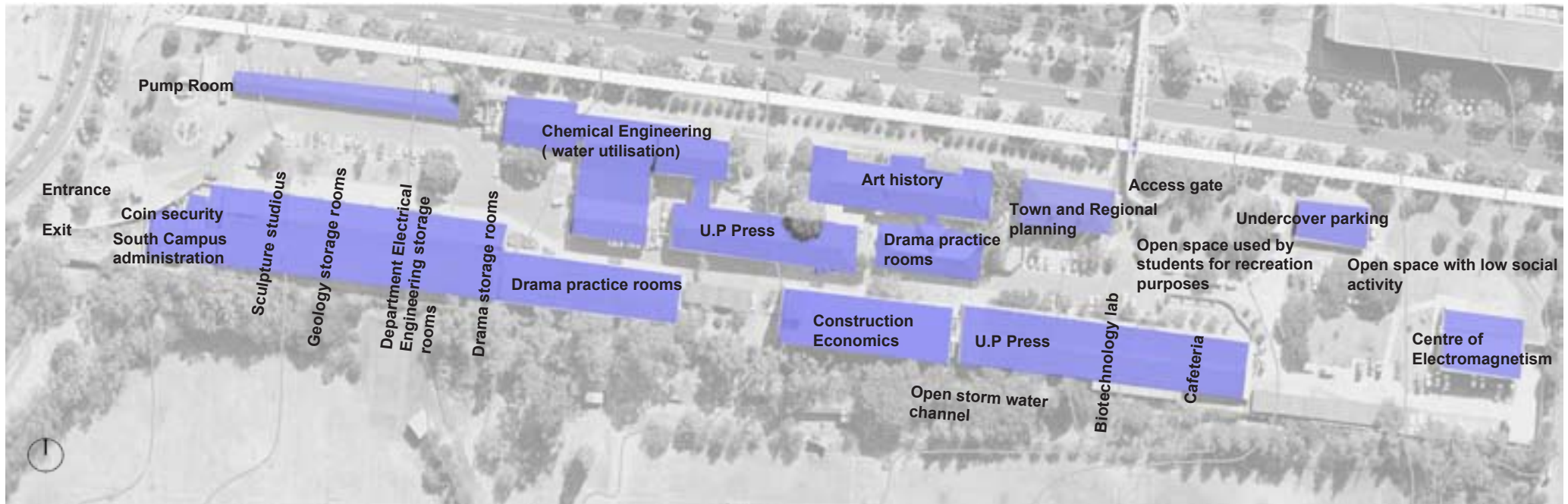

Fig. 3.51 Site activities.



Fig. 3.46 – 3.50 Physical sequence.

Main pedestrian movement and access

Pedestrians entering from outside university property use the gates which are situated west on University Road and north, on Lynnwood Road. Some students entering South Campus from the Main Campus use the pedestrian bridge over Lynnwood Road, others prefer crossing Lynnwood Road at street level. The access gate on Lynnwood Road functions as the main pedestrian entrance. The highest pedestrian activity is situated around this area because it is located close to an open area of grass and the cafeteria.



Fig. 3.52 Pedestrian dispersal and concentration.



Fig. 3.53 – 3.58 Physical sequence.

There is virtually no pedestrian movement towards the eastern side of the site and very little pedestrian movement towards the west. Pedestrians moving in an east west direction share the circulation route with vehicles, this sometimes lead to conflict between vehicles and pedestrians. Pedestrian movement in a north south direction is only short distances between buildings.



Fig. 3.65 On site circulation.



Fig. 3.59 – 3.64 Physical sequence.

Existing Structures

Buildings are seen as elements part of the landscape rather than discrete objects standing in isolation.



- Buildings with no significant value
- Building/Structures which can be removed
- Buildings structures to be upgraded
- Buildings with historical value

Fig. 3.66 Building grading.



Existing backs of buildings

Building access points

Fig. 3.67 Building access.



Social activities

The main entry onto South Campus from Lynnwood Road. It forms a gathering space as students wait for their turn through the access control gate.



"Most of the time the same people come here over and over again" (Cafeteria owner)

The front porch of the Town and Regional Planning building are very well utilised by students. Benches and low rise seating walls encourages social interaction.



"The campus is like a small community, everybody knows everybody" (Town and Regional planning student)

**"The distances from Main Campus is so far."  
(Fine Arts student)**

**"It's not so crowded here."  
(Fine Arts student)**

**"I come from Main Campus , the main attraction are the cheap food. "  
(Engineering student)**

**"Personnel , students and security workers buy from me."  
(Cafeteria owner)**

" We use the braai area sometimes on Friday afternoons " ( Town and Regional Planning Student)

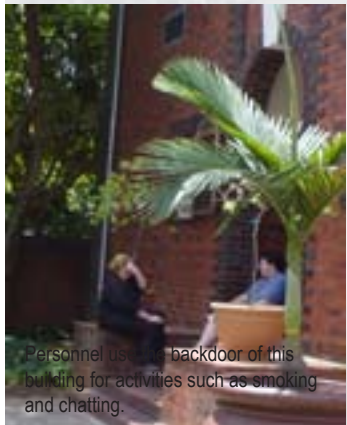

Personnel use the backdoor of this building for activities such as smoking and chatting.



Students prefer chatting and leaning against the edges of the building as it provides shade during the summer , they will rarely occupy this space during the winter.

Areas located away from pedestrian and vehicular movement are used for activities such as sleeping, studying and reading.

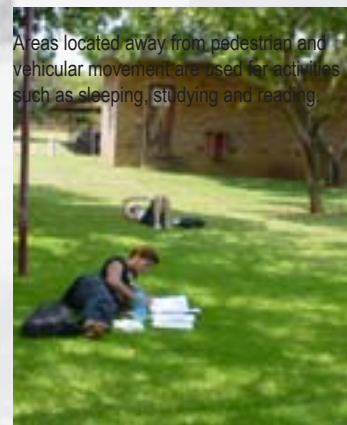

"The row of trees is significant for me." (U.P Press worker)

The space in front of the U.P Press building is usually occupied by staff which socialize under the trees when deliveries are received and collected.

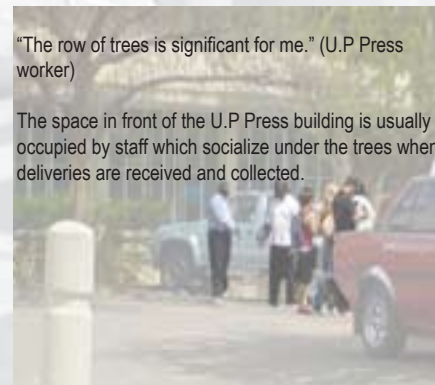

Students use this space in front of the cafeteria for eating lunch, reading, smoking, chatting and studying. There is a diverse range of seating provided, some are clustered together which are popular with groups of students. Other areas are used for one or two individuals.



Fig. 3.68 – 3.75 Social activity.



Urban Voids

Visual orientation

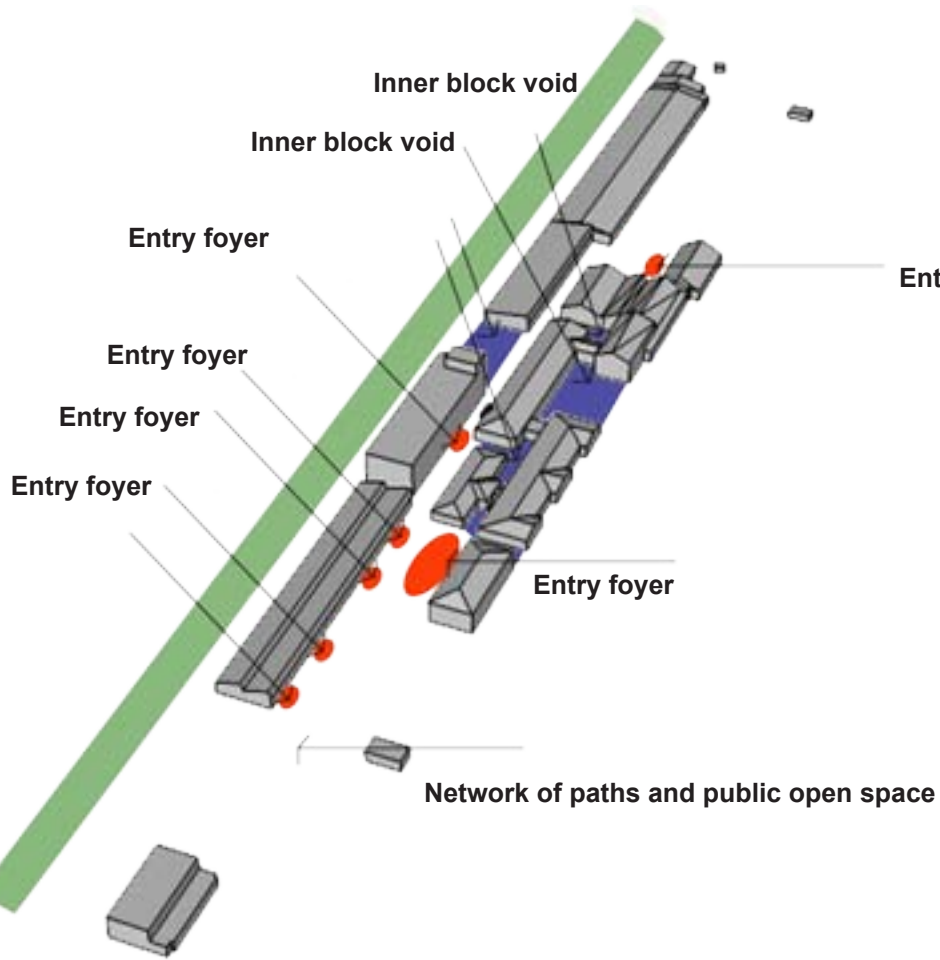

Fig. 3.76 Site voids.



Fig. 3.77 Visual orientation.

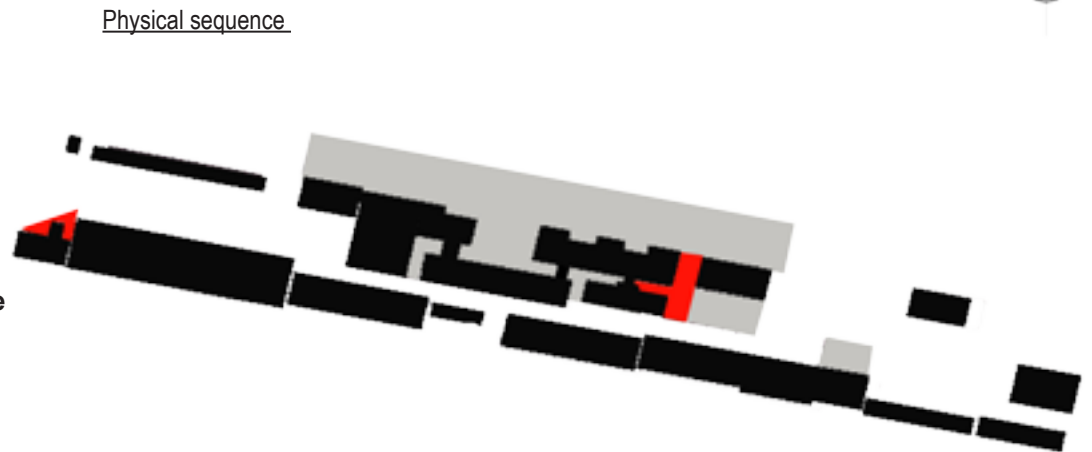

Fig. 3.78 Physical sequence.

-   Semi public
-  Semi private

Linkage

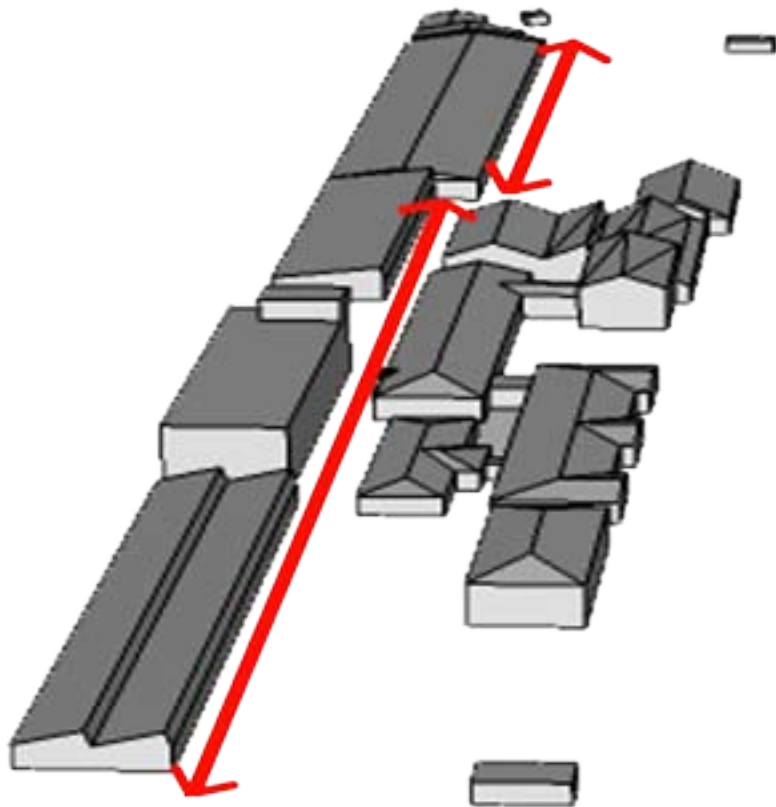

Fig. 3.79 Main linkage.

Lost space

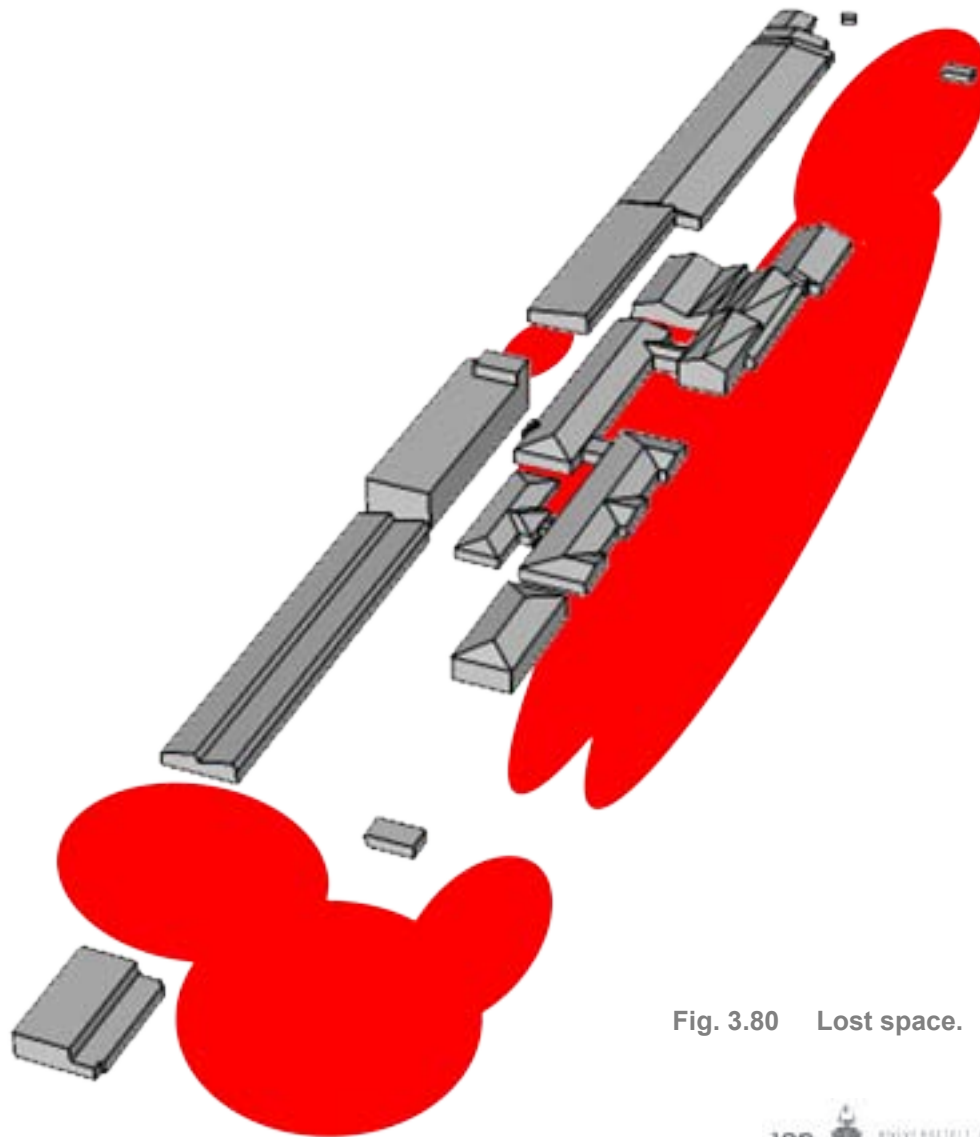

Fig. 3.80 Lost space.

## Physical Area Analysis

### Surface Geology

The area where the site falls has quite a unique geological appearance which consists out of mud stone, shale and sand stone which varies in depth in different areas.

### Topography

- Slope

1:56 from east to west.

### Drainage

- Soil drainage

Soil drainage is quite good as soils are porous which allows easy water drainage.

- Surface drainage

Gutters running along soft surfaces end, by spilling water onto hard impermeable surfaces. Precipitation falling on the hard impermeable surfaces are quickly carried away via storm water pipes, thus the water is contained and bypasses other landscape processes.

### Vegetation

The greater Tshwane falls within two South African biomes, the Grassveld and the Savannah biome; this has a result that the region is intermingled with species from both biomes, depending on site characteristics like slope water availability and soil type.

### Climate

The area has a warm and moderate climate; the mean daily sunshine factor is approximately 8.7 hours per day.

The average daily maximum temperatures are:

January 28.1°C  
(Max 37°C)

July 19.5°C  
(Max 25.9°C)



Fig. 3.81 Slope section.



The average daily minimum temperature:

January 16°C

July 3.6 °C

- Rainfall

The mean annual precipitation in Pretoria is:

494mm per year (min)

686mm per year (average)

1069mm per year (max)

The mean monthly precipitation in Pretoria is:

January – March 300mm

April – June 75mm

July – September 34mm

October – December 272mm

*(Carruthers, V.2000.)*

*(www.weathersa.co.za)*

- Wind

Prevailing, calm winds is mostly north - east and north - west, during summer, with an average speed of 2km /h. General prevailing wind direction in winter is from south east.

- Humidity

59%

*(AAL 310, class notes)*

Position of the sun

- Vertical sun angle

Summer solstice 21Mrt/23 Sept 64.24°

Winter solstice 22 June 40.73°

Solar incidence is high in the Pretoria region with a maximum of 67% sunshine in winter. The percentage translates into solar radiation energy as 8 Whr/m<sup>2</sup>/day in summer and 4.5Whr/m<sup>2</sup>/ day in winter.

*(AAL 310, class notes)*

## Legislation

National Water Act

National Heritage Act

Wetland Management

Storm water management – performance criteria

Disabled persons and the urban environment

Building codes regarding loading zones.

## Synthesis

### Historical synthesis

The South Campus was not a part of the initial planning of the university and is therefore disconnected from Main Campus. Buildings and their relationship with outdoor spaces were not designed to function as a campus. Over the years the site has changed from a place which hosted a specific use (administration offices and research laboratories) to a place which hosts a diversity of uses and a variety of people. There is a need to accommodate the different uses of the place. It can be concluded that the history of the site is one of the main reasons for its disconnection from Main Campus. The site edge can be made more legible by enhancing the historical buildings and relating the landscape to the existing elements on the site and its surroundings.

### Urban synthesis

The site is separated from the central area of activity due to the more residential area surrounding it. There is a need to promote the integration of public facilities with other activities. A primary use or anchor is necessary on South Campus to draw people into the site and strengthen the connection between the two campuses.

South Campus functions as a district separated from the Main Campus, these two districts should be connected. Thus, I support the general vision of transforming the social, physical and virtual fragmented image of the University of Pretoria into an inter related whole, which will function in a symbiotic relationship. (Refer to appendix 1)

Nutrients from the sport field fertilization can cause high concentrations of phosphorous and nitrogen in the water. This causes algae blooms which degrade the quality of fish habitats and other organisms which are vital for down

stream health. Due to the sandy conditions of the soil, the area is prone to contamination by nitrogen.

Lynnwood Road, which functions as an edge should be more defined. Both the connection of the two districts and the definition of Lynnwood Road can be achieved through appropriate streetscaping along both sides of Lynnwood Road. There lies an opportunity to create a strong landscape identity along Lynnwood which will visually connect South Campus to Main Campus.

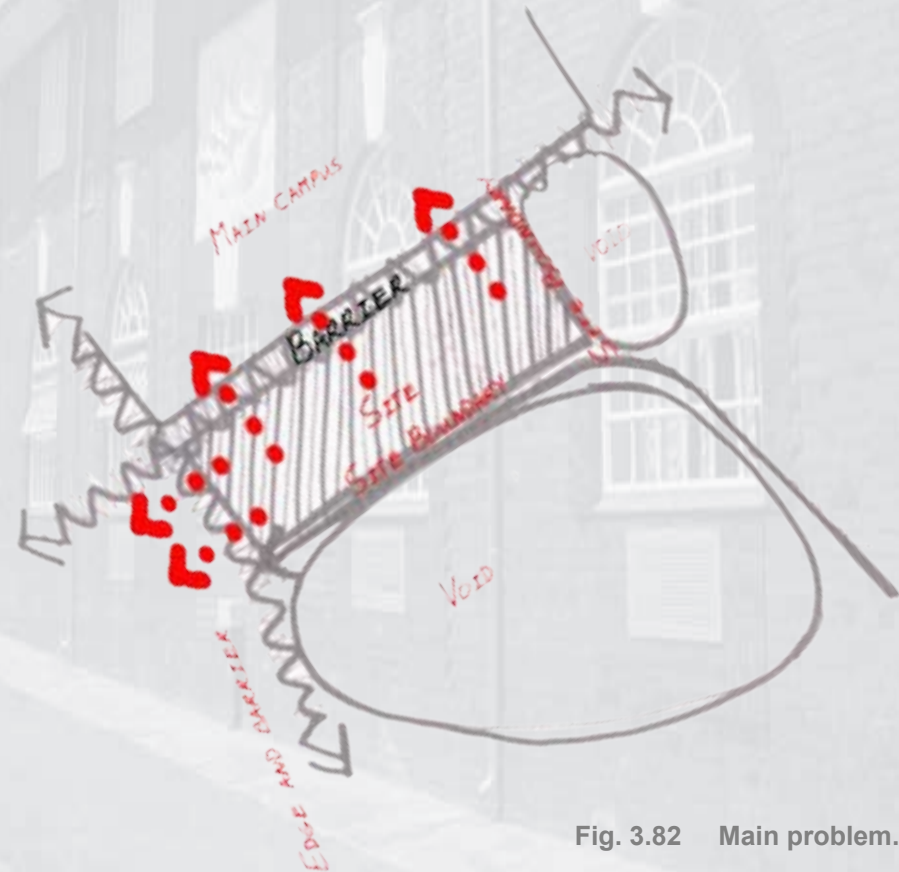

Fig. 3.82 Main problem.

### Precinct Synthesis

The dislocation of the site is a result of physical entities on the peripheries. Streets are the predominant urban elements and act as guidebooks to any city. Presently neither Lynnwood nor University Road has any prominent activity along its edge; the introduction of special landscape characteristics can enhance the prominence to the user.

The site is not responsive as it offers little choice of access and visual permeability is decreased by dense vegetation. Lynnwood Road has the potential to become more legible. Lynnwood Road edges should be more continuous and existing gaps in the urban fabric should be filled.

Piped drainage which has been designed to carry excess water away from urban surfaces has major effects causing flooding which impairs water quality. Storm water drainage must be designed to correspond as closely as possible to natural drainage patterns. Through the use of infiltration trenches it allows storm water to be treated at source.

Toxic materials from roads contribute materials such as zinc, lead, manganese and cadmium to waters. These elements also kill organisms by cutting off oxygen supplies. In order to minimize the problem, buffer zone needs to be considered early in the design process. These zones need to be populated by plants which have the ability to remove toxic as well as organic substances from the water. (Harris, C. & Dines, N. 1997)

### Site Synthesis

Courtyard spaces in between buildings, just of side the major pedestrian flow act as eddy spaces. These spaces are well located to function as quiet study areas, as the surrounding buildings block noises from Lynnwood Road.

Vehicles, trucks and service vehicles have the predominant right of way on the campus; this should be prohibited by redesigning vehicular access routes. To get concentrated pedestrian flows extra magnet facilities is necessary to attract a large number of pedestrians.

By analysing the current site figure ground the relationship between solids and voids is poorly balanced, this results in disjointed fragments which becomes lost space. The figure ground should be changed by the selective infill of buildings to establish definite edges and urban open spaces.

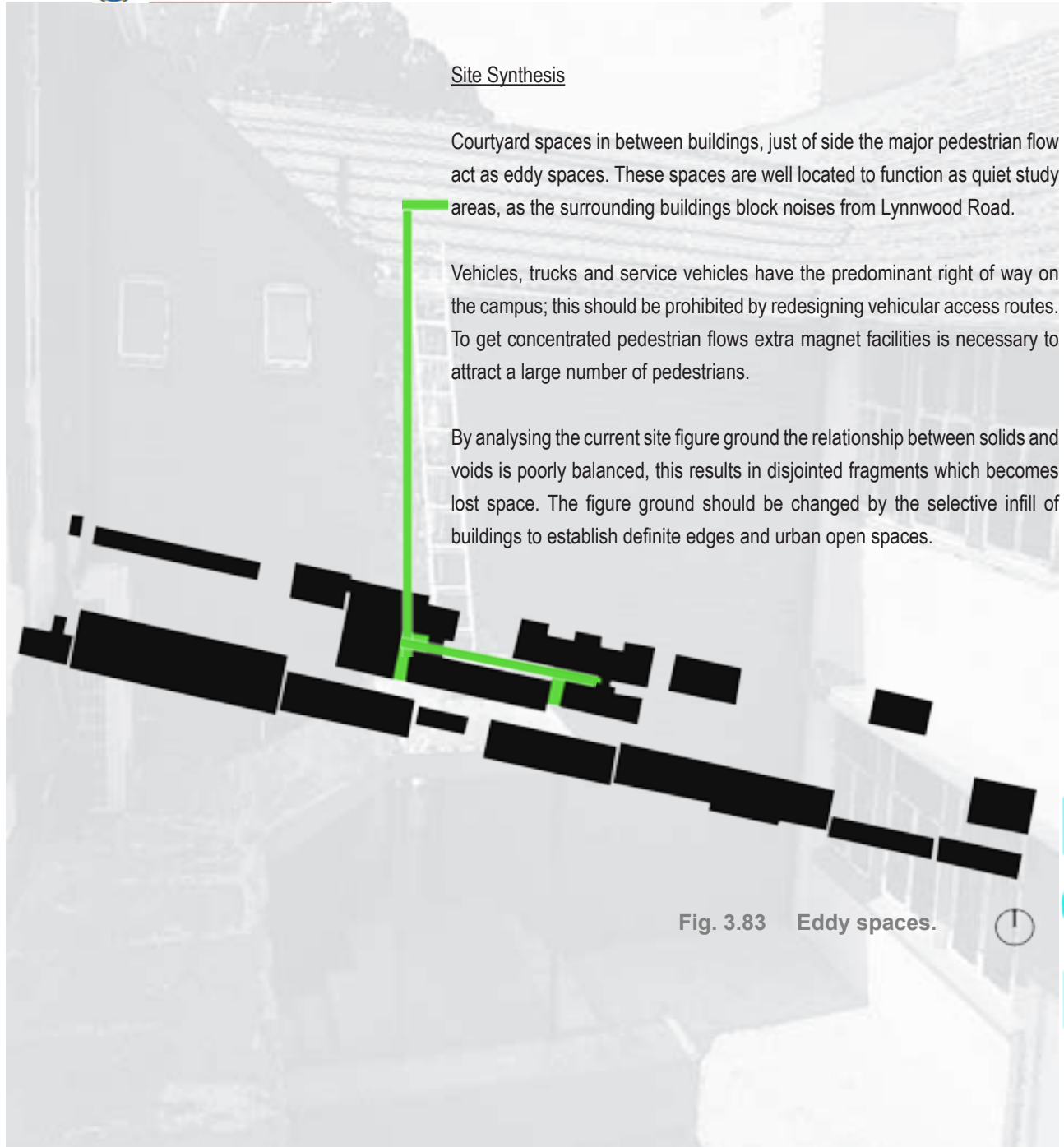

Fig. 3.83 Eddy spaces.



The existing strong circulation axis running in an east west direction should be accentuated and adjacent spaces should be designed in order to give the feeling of transition from one space to the next.

The gaps on the northern edge fronting on Lynnwood Road should be filled in to enhance the consistency of the urban edge. The articulation of this edge should respond to both the needs of the interior and the exterior. The existing main public space edges should be better defined by treating the edges and increasing the height of the building which contains the kiosk, the U.P Press and the biotechnical lab. Existing indoor activities should contribute, where possible to, outdoor activities. Visual contact contributes to animating the public edge.

### Physical Area Synthesis

A close study of the site's natural processes offers a possibility for new forms and arrangements to be revealed.

Topographically the site is ideal for making accessible open spaces. A gentle slope facilitates easy movement through the site. The gentle east west slope ensures good storm water drainage. Introduction of water features might be a possibility as it can be well maintained. There consist an opportunity in creating a new symbolism for water which reflects the hydrological processes of the urban environment.

As temperatures are mostly pleasant, and rain most often occurs during summer months in the form of thunderstorms, the site lends itself to intense outdoor use. The potential for wildlife to survive in the urban environment will depend on the complexity and the size and shape of habitat.

Soil toxicity can play a role in places, due to the deposits of toxic substances and substrates as a result of pollution from past site activities.





# CHAPTER 4

## PRECEDENT STUDIES

## CHAPTER 4 PRECEDENT STUDIES

### Introduction

"Precedent refers to what has preceded us or come before in time." (Righini, P. 2000.) The chosen precedent studies are concerned with the issue of form, structure, scale, spatial characteristics and context.

### Precedent 1

## Park Duisberg Nord, Emscher park, Germany

### Latz and Partners

### Duisberg

### Importance of study

The project illustrates how ecology and the existing infrastructure on the site can be harmoniously integrated so that it forms living structures and systems.

### Background

Similar to South Campus, Park Duisberg Nord also contains existing structures which were designed for industrial use. The structures were adopted, redeveloped and reinterpreted. The design aims to celebrate the areas industrial past by integrating vegetation and industry. ([arch.hku.hk](http://arch.hku.hk)) A specific element, the train tracks running through the site, forms the main components for linking the different spaces in the park. The various spaces are laid out based on the context, both spatially and conceptually, thus emphasising, through adaptation and reinterpretation, the transformation of the old industrial park.

(Baumeister, N & Pitz, H. 2007)

Fig. 4.1 The promenades of Duisberg Nord Landscape Park.

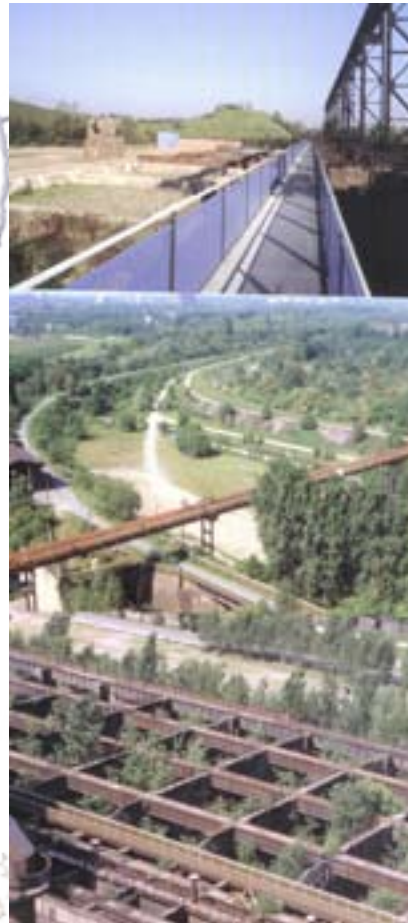

Main design objectives:

The power of ecology as an integrating concept

Adaptive reuse of industrial buildings

The use of art in the landscape

([www.georgewright.org](http://www.georgewright.org))

The approach to the designing of the park allows natural processes of growth and decay to take place with minimal intervention. ([www.cabe.org.uk](http://www.cabe.org.uk))

Duisberg Nord has set new platforms for reclamation. The design of the site was guided by existing infrastructure and social and environmental restoration. Ignoring the sites history and erasing its contradictions would have been less convincing. In such circumstance the role of the designer is to decide what to retain, what to transform and what to replace. ([www.gsd.harvard.edu](http://www.gsd.harvard.edu)) By ecological restoration, isolated spaces were successfully integrated. The incorporation of natural vegetation and the process of growth and decay reduce the cost of maintenance regimes. (Hough, M. 2004) The park challenges the way humans relate to the land, the landscape is in constant change, different seasons reveals different planting patterns. (Architecture, November 2000)

### Summary

It offers an integrated approach and acknowledges the relationships between the physical and the biological process. The project offers an environment where users have a "thought provoking" interaction with structures, green spaces and natural processes.

Fig. 4.2 A square of trees in the midst of steel giants.



## Precedent 2

### Parque Ecologico Xochimilco

Mario Schjetnan

Mexico City, Mexico

#### Importance of the study

The park is an illustration of sustainable management of a natural area, recovered in an urban area, the park functions as a model to other areas in the city and even to other cities. ([www.redscolar.icle.edu](http://www.redscolar.icle.edu))

#### Background

Xochimilco is a part of Mexico City which is a portion of a pre-conquest landscape. The landscape consists out of artificial garden islands, created in a lake that once filled a large valley of Mexico. The project addresses the challenges of urbanization in the most populous city in the world ([www.redscolar.icle.edu](http://www.redscolar.icle.edu)). The increasing pressure of environmental degradation and urban development increased the amount of storm water runoff and subjected the area to increased flooding. The whole Xochimilco was redesigned guided by hydrological strategies. At the end of Xochimilco lies the park, whose different zones accentuate natural, recreational and interpretive areas. The park articulates remediation as well as sustainability and achieves this in multiple scales. ([www.gsd.harvard.edu](http://www.gsd.harvard.edu))

#### Summary

The park, just as my view for South Campus, is a microcosm of the larger landscape, highlighting its ecological, historic, agricultural and recreational attributes. The park does not just engage the aesthetic, but it functions as a working landscape, recovering ecosystems without forcing nature.



Fig. 4.3 Parque Ecologico Xochimilco.



Fig. 4.4 Aerial representation of Parque Ecologico Xochimilco.

### Precedent 3

## 44 Stanley Avenue, Brian Green Braamfontein, Johannesburg

#### Importance of the study

This is a local example of how designers have dealt with the recovering of areas and spaces which were in the past used for other activities.

#### Background

This site falls within the Newtown precinct, an area which was previously known for its industrial activities. Presently lots of the old factory buildings in the area have been upgraded for commercial activities. A dilapidated cluster of workshops, consisting out of 1, 2 and 3 storey buildings has been transformed into a space filled with shops and restaurants. The initiative behind 44 Stanley Avenue was to create a centre driven by retailers and business people. The overall industrial character has been maintained and minimal changes have been made to the existing structures. The whole complex has a playful feel to it, with some passages leading to nowhere. ([www.44stanley.co.za](http://www.44stanley.co.za)) Green says he particularly wanted to include children *"Kids keep the atmosphere light."* ([www.joburgnews.co.za](http://www.joburgnews.co.za)). The site is situated in an immediate context which consists of several art galleries, as well as the film school Afda.

#### Summary

There is greater potential than to merely rehabilitate and give old industrial areas new activities like these. Correct methods of regenerative design should be applied, which not just include the social and economical but also the environmental. The site accommodates various activities which attracts a broad spectrum of people. This ensures that the site is always "alive" during night and day time.



Fig. 4.5 Alley between buildings.



Fig. 4.7 Enclosed space.

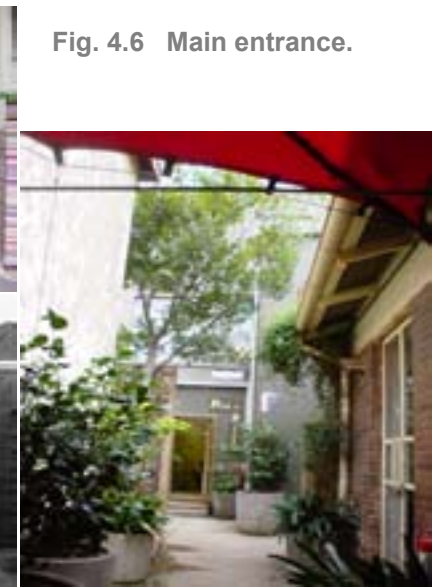

Fig. 4.8 Interior courtyard.



## Precedent 4

### Maurice Rose Airfield strip

#### GTL Gnuchtel Triebswetter Landscape Architects Frankfurt

##### Importance of the study

The project illustrates ecological succession, the reuse of surface materials and how the overall character of the site can be maintained.

##### Background

The site of the old airport, which was abandoned, forms part of a green belt and lies in a former floodplain. New user groups discovered the large space free of traffic and it is used for activities such as rollerblading and cycling.

There was an engagement by the nature protection council to decrease the amount of asphalt surface. Existing buildings were not demolished; the history of the military and the overall character of the landscape were maintained through its unique structure and materiality. At the same time the process of returning nature can be seen. Earth fields, modelled broken concrete and successive observation fields have been created.

*(Baumeister, N & Pitz, H.2007.)*

Concrete and asphalt relics will generate an interesting plant mosaic ([www.eurohypo.com](http://www.eurohypo.com)). The design was able to successfully mediate in strategic, yet simple ways to retain the feel of the old use. Left over rubble is contained in gabions to create seating. The asphalt expanses remain on the site in some



Fig. 4.9 The Nidda flood plains are coming into their own again.

locations, but have been broken up to create drainage. The image is a reminder that all is very close to a metropolitan area. *(green-journey.blogspot.)*

The underlying character and architectural structure of the ground remains legible. The unique feature in the new recreational open space is the way it deals with asphalt and concrete. More than half of the hard surfaces were broken up and shattered into grains of different sizes. This creates a mosaic with very different patterns in the course of the succession. The areas of poured in-place concrete appear as if floating in the fields of shredded concrete slabs. ([www.eurohypo.com/media/pdf](http://www.eurohypo.com/media/pdf).) The roughness of the redesigned site gives a new look of design possibilities in public green space. *(Baumeister, N & Pitz, H.2007.)*

##### Summary

The design visually illustrates and captures the juxtapose between ecology and the existing infrastructure into a unifying whole.



Fig. 4.10 Site plan.

## Precedent 5

### Goteborg , Sweden

#### Importance of the study

This framework design for the city of Goteborg, shows various methods of how lost spaces can be conceptually integrated back into the city structure. The city experienced, although in a much larger scale, the same problems as the site and its surrounding context.

#### Background

The centre of the city was intersected by canals with parallel streets on either sides of the canal. The pressure of increasing traffic jams resulted that the canals were filled which created wide streets, sometimes up to 34m in width. By the end of the 1950's serious problems faced the transport system. By the mid 1960's the average speed of cars were the same as horse drawn cars. This resulted that the public transport system became unreliable and pedestrians was in a constant struggle to cross streets. (*Organisation for Economic Co Operation and Development. 1974.*)

The City Planning and Development Office identified five major sites of lost space within central Goteborg. Most of these spaces were misguided or simply a result of historical transformation as previously mentioned. These spaces were identified at points of pedestrian transition between districts.

Recommendations for these areas included, infill, building of public spaces, arcades, bridges, platforms, plants and water.

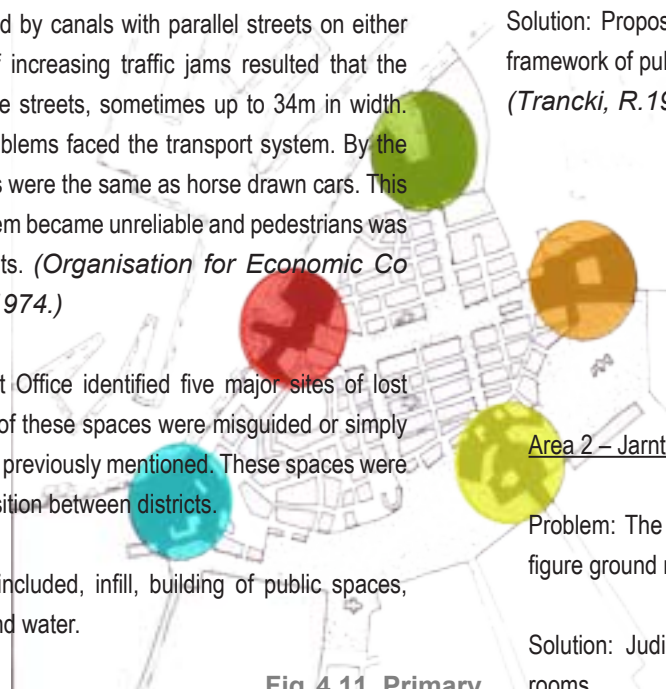

**Fig.4.11 Primary spatial structure of the city.**

#### Area 1 – Lilla Bommen

Problem: At the Lilla Bommen harbour the highway separates the formal connection to the waterfront.

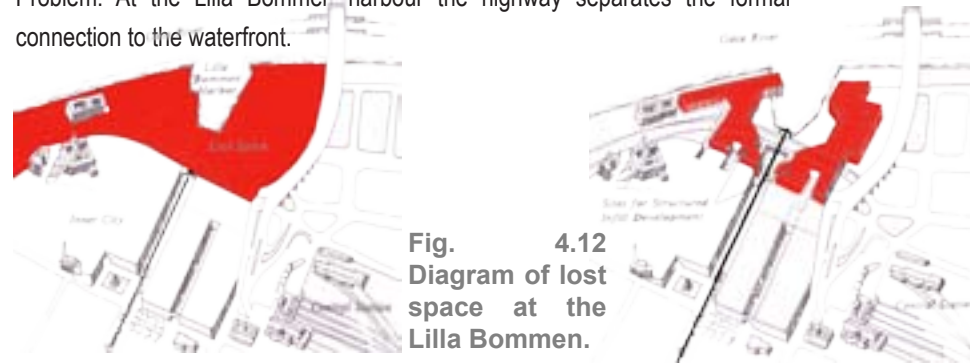

**Fig. 4.12 Diagram of lost space at the Lilla Bommen.**

Solution: Proposed infill development. The important concept is to impose a framework of public space into which individual buildings can be attached. (*Trancki, R.1986*)



**Fig.4.14 Diagram of lost space at the Jorntorget.**

#### Area 2 – Jarntorget

Problem: The new buildings fail to provide the enclosed structure and a new figure ground needs to hold the site together.

Solution: Judicious infill could restructure the spaces as a series of urban rooms.

(*Trancki, R.1986*)

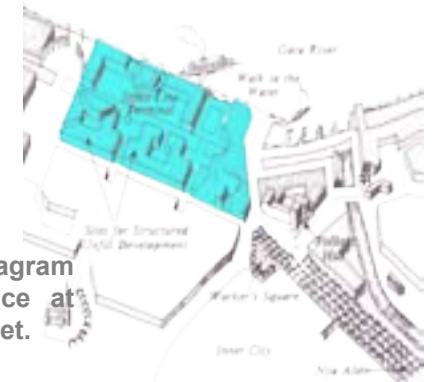

**Fig. 4.15 Proposed infill at the Jorntorget.**

Area 3 - Kingsportsplaten

Problem: This entry is a formless zone and the entry announcement is destroyed by vast expenses of paved surfaces and parking lots.

Solution: Proposed infill buildings create a strong defined entry.  
(Trancki, R.1986)



**Fig. 4.16** Diagram of lost space at the Kingsportsplaten.



**Fig. 4.17** Proposed infill at the Kingsportsplaten.

Area 4 – Stenpiren

Problem: Stenpiren is a gateway from the water as one enters the city from the water. Traffic is a major barrier between the site and the river.

Solution: The area could be incorporated into the city by bridge buildings across the roadway.  
(Trancki, R.1986)



**Fig. 4.18** Diagram of lost space at Stenpiren.



**Fig. 4.19** Proposed infill at Stenpiren.

Area 5 – Drottningtarget

Problem: The Square is ill formed with the central station in the centre a post office and dispersed retail buildings. Confused transportation systems and wind from all directions leaves the pedestrian at a complete loss.

Solution: The main concept is to carve a pedestrian sanctuary in the centre of the square. Additional buildings were added to close off the edges and corners. The proposed reconstruction creates an axial connection to tie the buildings into a coherent space and provide a strong central focus. (Trancki, R.1986)

Summary

These precedents shows broad scale integration, but they are also valuable for the integration of spaces on a smaller scale.



**Fig. 4.20** Proposed infill at Drottningtarget.

## Precedent 6

### Shenyang Architectural University

#### Turescape

#### Shenyang, China

##### Importance of the study

This precedent demonstrates the ability and the opportunity of a campus landscape to become a model of innovative ecological thinking for future students. The concept of agriculture as a non traditional campus form gives the university a progressive identity.

##### Background

The most important aspect of this non conventional campus design was the acknowledgment that an innovative university design affects the thinking of people at a critical point in personal development. This innovative design was aimed at raising awareness amongst students that productive landscapes can become useable spaces through careful design. The illustrated regenerative process becomes transparent and accessible to all students on the campus.

Not only were physical links achieved by designing paths through the rice fields, but also symbolic and functional links which are achieved through the design of a rice paddy which produce food consumed in the campus dining facilities.

Negative aspects of this design include the lack of visual variety in open spaces and physical links between buildings and the landscape were insufficient.

Courtyard spaces in between buildings became inaccessible; the design could have been more successful if the courtyards were designed for leisure and study. The level of environmental awareness, applied in the landscape, was not employed in the buildings.

*(Landscape Architecture, December 2006.)*

*([www.asla.org](http://www.asla.org).)*

##### Summary

Although this campus design is primarily focused on the regenerative aspects of food production it illustrates how physical links between students and the regenerative landscape can be achieved.



Fig. 4.21 Aerial view of Shenyang Architectural University.



# CHAPTER 5

## DESIGN PRINCIPLES

## CHAPTER 5 – DESIGN PRINCIPLES

### Introduction

The importance of the design principles is to form links between the theoretical framework, the problems identified in the site analysis, the issues addressed in the precedents and the driving force behind the design concept. As concluded the universal, grounded urban design principles are not exclusively appropriate for my design approach. I need to consider the regenerative aspect, which is lacking in contemporary urban design principles.

Thus the principles synthesise theory and practice by means of material technologies which are not considered as objects, but rather as processes which occur in varying scales. The terminology is composed of verbs and adjectives that allude to the human body and its complex life cycle. There are seven principles, each focusing on an operative aspect of landscape. (Margolis, L. & Robinson, A. 2007)



Fig. 5.1 Design principles.

Fig. 5.2 Vertical landscape.

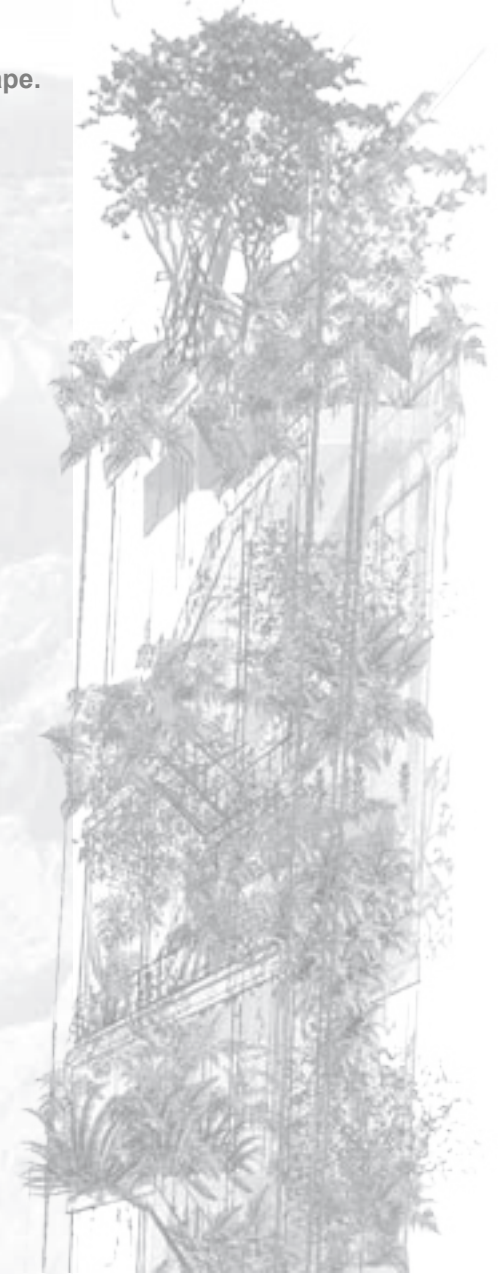

## Launch

Landscape - Architecture interface

Adaptable

Active responsive skin

*(Margolis, L. & Robinson, A. 2007)*

## Digestive

Metabolic system of ongoing processes

Self contained

In situ

*(Margolis, L. & Robinson, A. 2007)*

## Stratify

The ground as a 3D profile conceived as an epidermis like structure

Integrated into layers

Gradual variation between material compositions

*(Margolis, L. & Robinson, A. 2007)*

## Translate

Landscape as communication

Provide information through interactive and reactive operations

*(Margolis, L. & Robinson, A. 2007)*

## Fluid

Process of movement

Detention and conveyance of water

*(Margolis, L. & Robinson, A. 2007)*

## Volatile

Weather dynamics can be conceived as a tectonic landscape experience

*(Margolis, L. & Robinson, A. 2007)*

## Grooming

Continuum of action

Choreographed performances

*(Margolis, L. & Robinson, A. 2007)*



The background of the slide is a grayscale image of a building with a large arched window and a group of people sitting on a bench. Overlaid on the left side of the image are three overlapping rectangular boxes: a cyan box at the top left, a yellow box in the middle left, and a red box on the far left. The text 'CHAPTER 6' is written in a large, green, hand-drawn font, and 'DESIGN RESOLUTION' is written below it in a smaller, green, hand-drawn font.

# CHAPTER 6

## DESIGN RESOLUTION



## CHAPTER 6

# DESIGN RESOLUTION

### Program

A program involves organizing a precise and detailed listing of requirements, both human and environmental.

The program includes:

Restoring ecological systems and cultivating a sustainable landscape

Environmental education

Environmental education must be in places where people live and work. This can be achieved by making ecological processes visible in the landscape.

Environmental education includes the following:

- Illustrating techniques of water conservation by reducing storm water runoff from the site
- Habitat creation
- Illustrating methods of recycling materials on site.
- Social gathering areas in a variety of places.

More secluded spaces for people to study and read

A public square with outside seating at the newly proposed School of Motion Picture Production

A suitable open space to be used by art students for drying sculptures.

Upgrading the streetscape in Lynnwood Road

A service road accessible to the majority of buildings

Pocket parks in existing open land around the site.

Open green space within the site boundaries

Centre of Earth Studies which includes a nursery and laboratories for the study of the succession of vegetation within the regional biome.

## Users

### Primary Users

- U.P Students
- U.P Lecturers
- U.P Press personnel

### Secondary Users

The public which will visit the School of Motion Picture Production , which will include the general public as well as school groups from Pretoria Boys High, Pretoria Girls High and Afrikaans Hoër Meisies and Afrikaans Hoër Seuns.



Fig. 6.1 Group of people.

# URBAN FRAMEWORK

## Urban Framework

### Introduction

The urban development framework supports the philosophy and vision statement of “Transforming the University of Pretoria from an isolated fragmented knowledge production institution, to a University City, a city of innovation. “ By referring to the framework (appendix 1) it will specifically focus on:

- The removal of physical, social and virtual boundaries which are constraining the University’s growth.
- The university as a village where the exterior spaces act as outdoor rooms for academic discourse and social play.
- The functioning of the university village as a community, working as an inter related whole, a symbiotic relationship of allied unions.

### Urban Problems

After a thorough study of the site analysis the main urban problems were identified

- South Campus is not integrated into Main Campus
- Due to the site’s history South Campus is not designed for educational programmes and activities.

### Resolutions

- Integrate South Campus back into the urban realm.
- Establish a vision for South Campus where both buildings and landscape can relate to.

### Vision for South Campus

Existing locations of art related faculties justify the establishment of an art and culture precinct to generate ease of access between creative departments. Ecology and Technology forms the basis of all educational programmes, enabling the site to become a living laboratory. All academic programmes featured on South Campus by various faculties should include subjects in their curriculum which focus on ecological sustainability within their specific field.

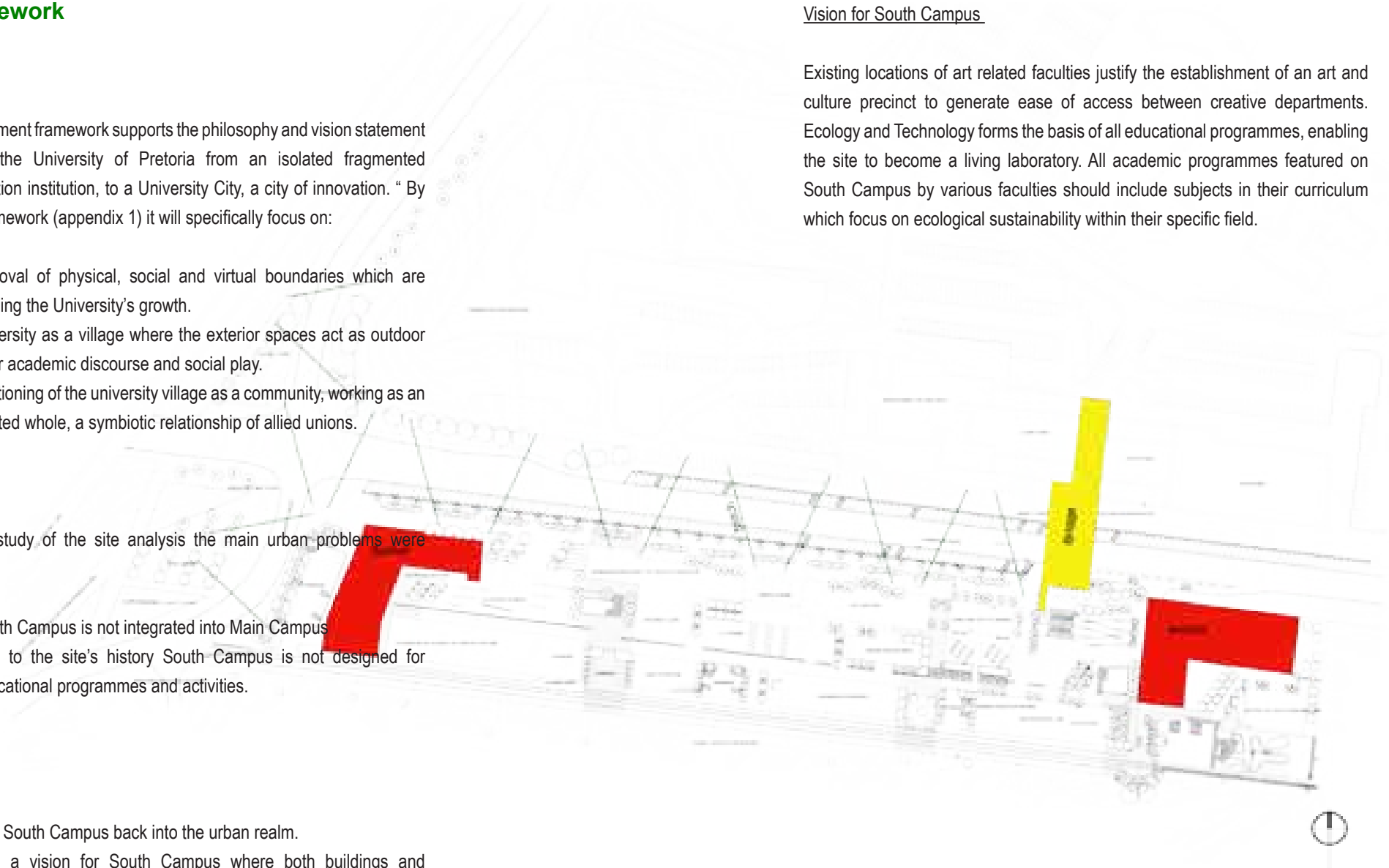

Fig. 6.2 Urban concept.

Campus Design Guidelines

- Common and customary setback lines.
- Visual unity between old and new.
- Design according to human scale.
- Campus buildings should pose a transparency which helps to increase a feeling of involvement.
- Campus should offer a variety of spaces with a variety of activities
- Quality interface between town and campus.
- Landscape should respond to existing buildings.
- Clear and convenient circulation routes.

([www.pp.okstate.edu](http://www.pp.okstate.edu))

Fig. 6.3 – 6.8 Campus design guidelines.

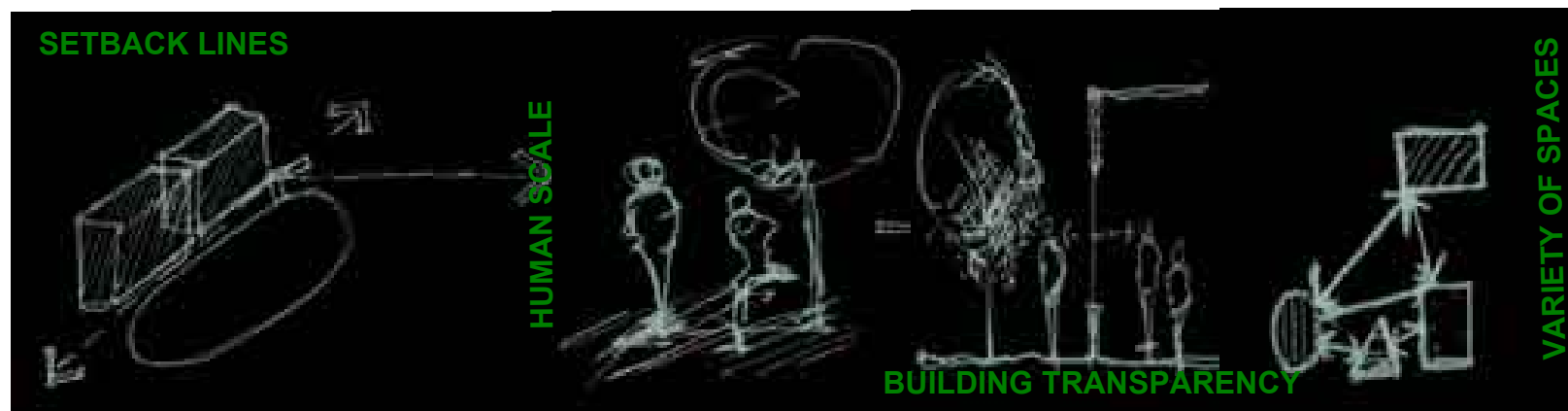
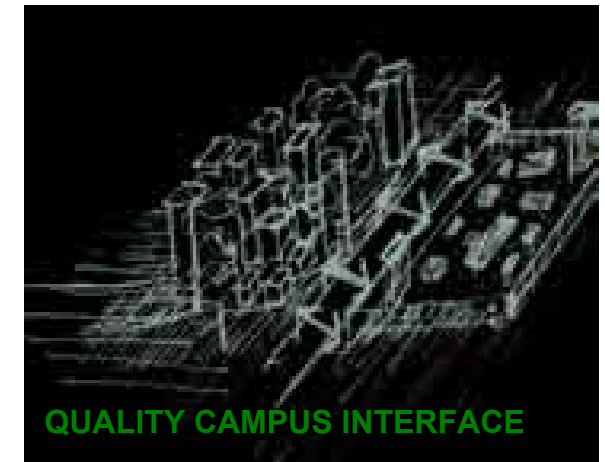
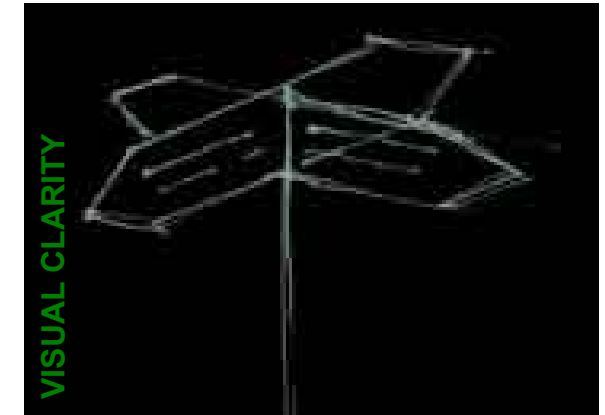

New Functions and footprints

The open pieces of land lying towards the west of the site should be an extension of the site and its activities. This urban gateway is also an introduction to the University precinct.



Fig. 6.9 Urban gateway.



1. Parkade
2. Centre of Electromagnetism
3. Cafeteria
4. Drama Studios
5. Biotechnical lab
6. U.P Press
7. Business Economics
8. Earth Centre
9. Art sculpture studios
10. Motion Picture Academy
11. Water Utilisation
12. Computer and Internet Centre
13. U.P Press
14. Art History
15. Town and City Planning
16. Art and Architecture intervention
17. Outdoor screen

Fig. 6.10 New site activities.



Building design guidelines for newly proposed buildings

(Refer to figure 3.66 in analysis)

All buildings which are demolished should be demolished in a manner which allows the different building parts to be erected elsewhere.

Building Envelopes

- Building envelopes should where possible consist of prefabricated units and should provide thermal comfort and generally energy efficiency.

Lighting

- There should be controlled distribution of daylight in buildings, using the daylight factor, as a design target.
- Indoor spaces should be grouped with similar luminous requirements
- Reduce consumption of electricity
- Optimize lighting effectiveness
- Visual comfort
- Energy efficiency through appropriate shading devices

Heating

- The use of passive solar heating to control climate and thermal comfort.

Cooling

- Effective cross ventilation for climate control and thermal comfort.
- Night ventilation of thermal mass

Energy production

- The installation of plug loads which represents the electrical consumption potential of all appliances

Water and waste

- Water re use and recycling
- Water catchment systems

(Kwok, G et al. 2007)

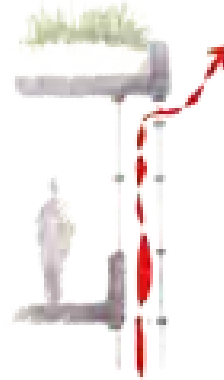

Fig. 6.11 Building envelope.



Fig. 6.12 Lighting.



Fig. 6.13 Cooling.



Fig. 6.14 Energy.

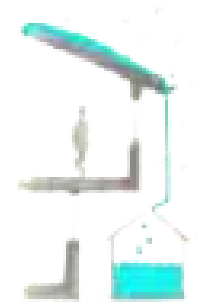

Fig. 6.15 Water and Waste.



Circulation and building access points

Pedestrian movement patterns on the site are determined by primary uses. A parkade on the east and a primary function on the west side will create a vibrant movement of pedestrians east – west across the site. Open areas adjacent to both these structures will allow for public squares. By further accentuating this particular axis the two big open squares on the western and eastern side of the site will be coordinated and better visual orientation is achieved.

The newly proposed bridge across Lynnwood Road will retain spatial continuity; the habitable bridge will become a pedestrian system onto which buildings can be glued.

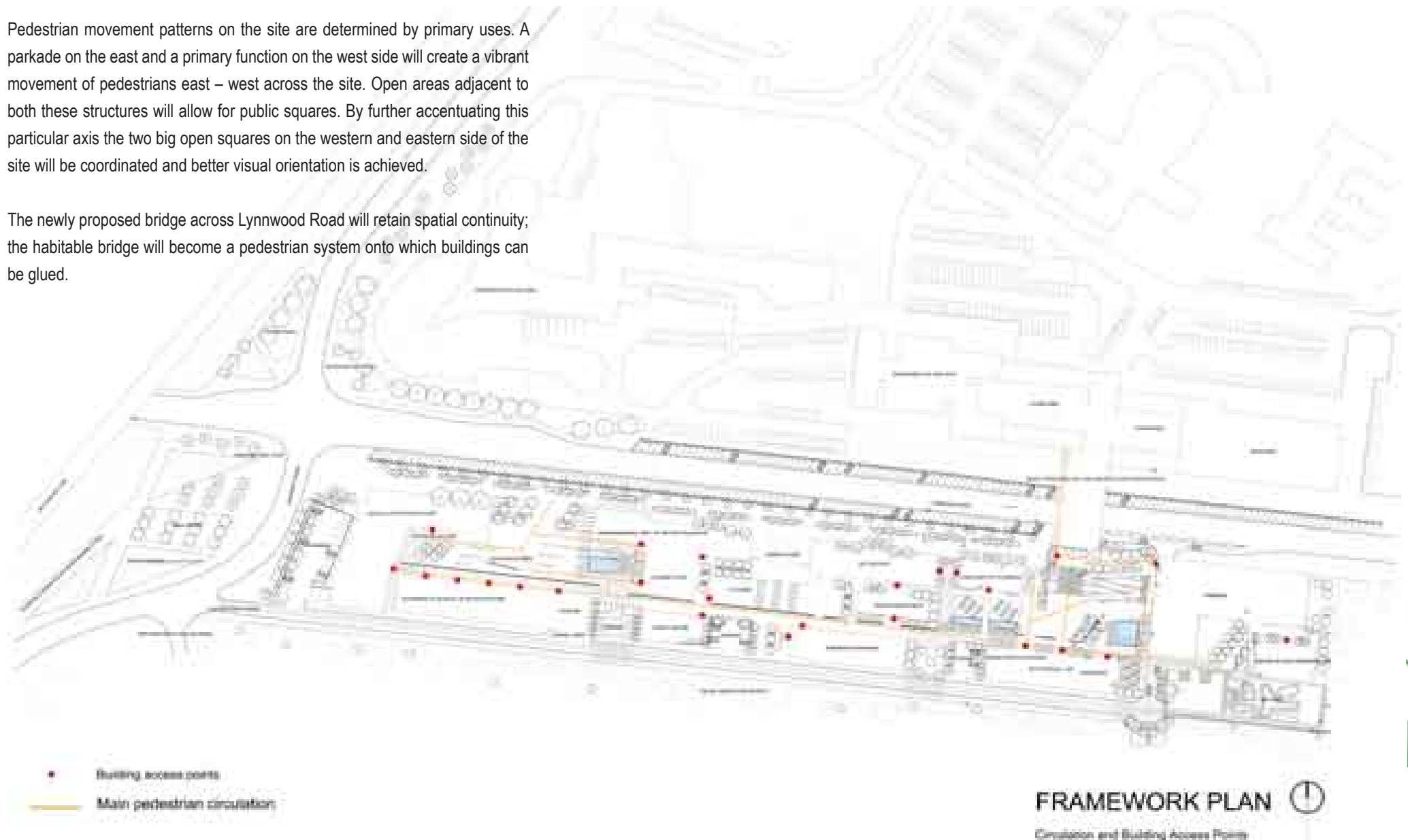

Fig. 6.16 Circulation and Building access.

Outdoor spaces

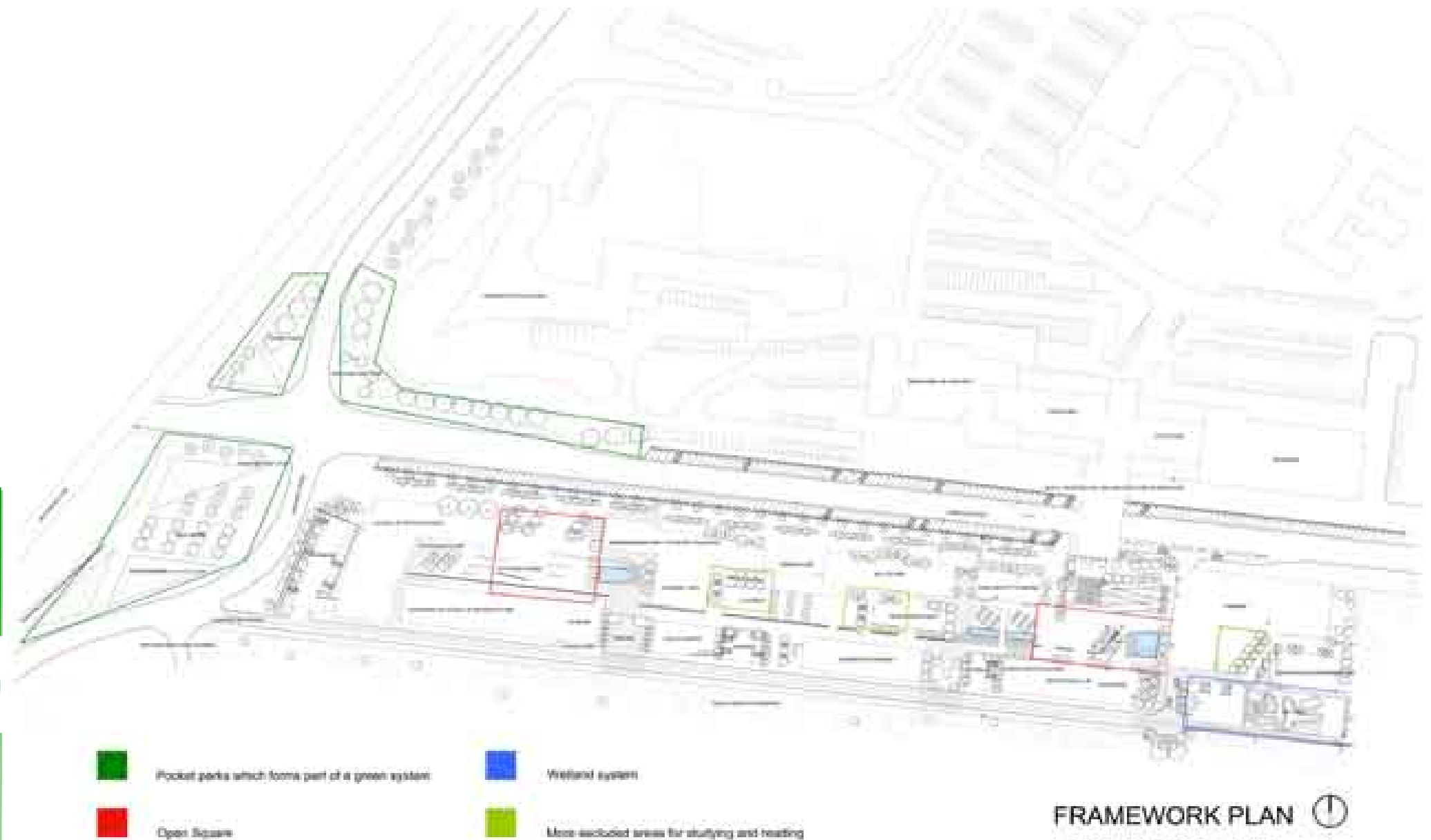

Fig. 6.17 Outdoor Spaces.

CONCEPT

## Concept

### Touchstone project

- Landscape as a stitch

The touch stone project image is an abstract and strong representation of what the project wants to be. The inspiration lies in the simplicity of the design, but the complexity of the detail, networks, transitions and stitches.

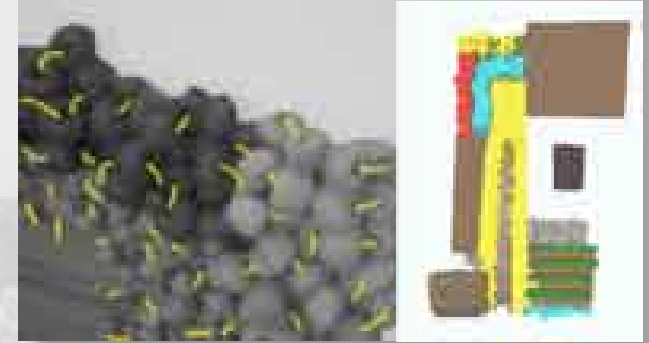
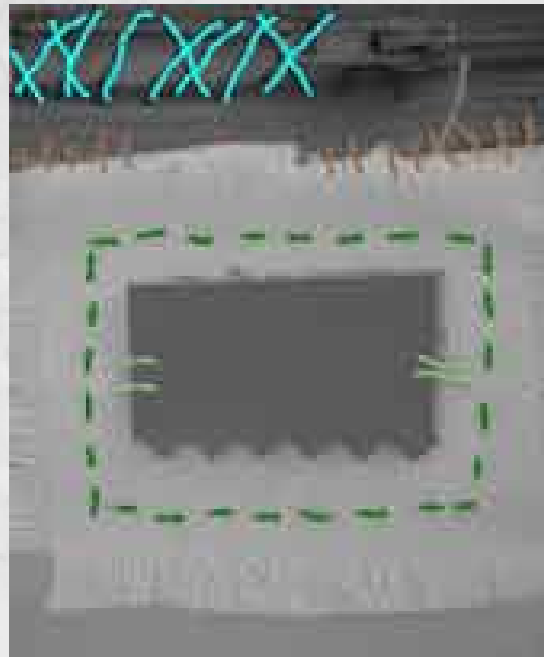

### Concept statement

From the theoretical review, site analysis, precedents, design principles and the touch stone project the following concept can be formulated:

**The links, which forms networks, are more important than the elements themselves.** The site's rich complex system of patterns and patterns within patterns offer a foundation for equally rich patterns of development. Here lie the means for establishing a living environment which will connect human and natural processes.

Fig. 6.18 – 6.21 Material stitched onto canvas.

## PHASE 1

SET UP INFRASTRUCTURE FOR WETLAND (SEEDS CAN BE HARVESTED FROM PRETORIA BOYS HIGH WETLAND)

ESTABLISH EARTH CENTRE

ASSEMBLE GREEN HOUSES

START WITH VERMI CULTURE

## PHASE 2

BUY SEEDS FOR THE THE GERMINATION OF THE FIRST PLANTING MATERIAL ON SITE

MULCH GROUND WITH EXTRACTS FROM VERMI CULTURE

GERMINATION OF SEEDS IN THE GREEN HOUSES

1. STRATIFICATION
2. FROM SEED TO SEEDLING
3. HARDENING OFF PHASE
4. ESTABLISH IN THE LANDSCAPE

PUMP WATER FROM THE NATURAL STREAM TO BE USED IN THE GREEN HOUSES AND THE LANDSCAPE

## PHASE 3

PLANT THE FIRST BATCH OF SEEDLINGS ON THE SITE AND ESTABLISH GROWING GUIDES WHERE APPLICABLE

THERE AFTER THE SITE WILL BE A HOST TO THE CONTINUOUS PROCESSES OF SEED HARVESTING, PROPAGATION, PLANTING AND MULCHING WHILE SUCCESSION IS REACHED

SYSTEM OF ONGOING PROCESSES WILL BE ABLE TO PROVIDE FOR EXTERNAL SOURCES

Concept development

Through the application and networking of the living systems building blocks the site will have the possibility to change from an open to a closed system sustaining itself.

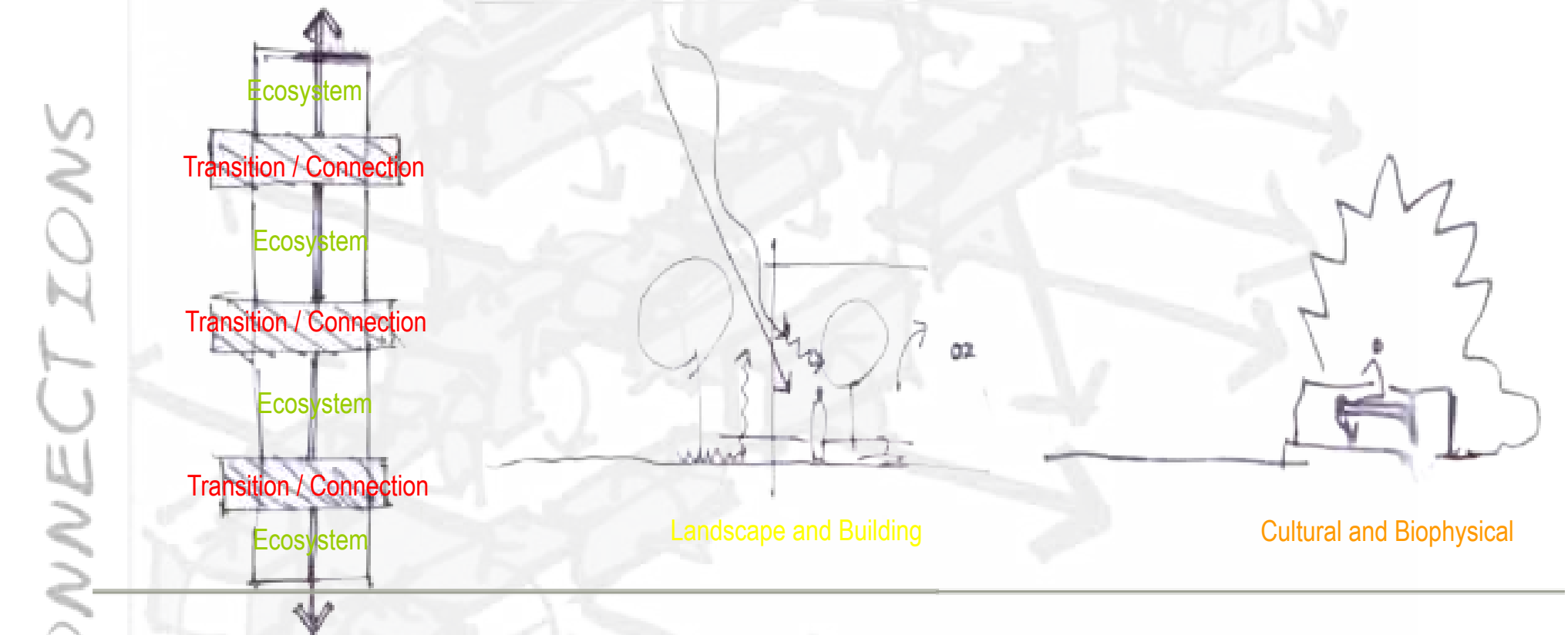

Fig. 6.22 – 6.24 Conceptual illustrations of different connections.

# LANDSCAPE FRAMEWORK

## Landscape Framework

### Introduction

The landscape development framework is necessary as it construes landscape as a process, rather than a product. As a result any project must assume the role of an open ended strategy for setting up future conditions. Thus, by reading the site as a living and dynamic micro organism it enables the designer to incorporate it into the larger field of effects.

### Important Edges and Connections

- Northern Edge towards Lynnwood Road

### On street parking

The existing on street parking on Lynnwood Road will remain as it is; this greatly minimizes the average speed of driving along Lynnwood Road. The existing Jacaranda trees will remain in place.

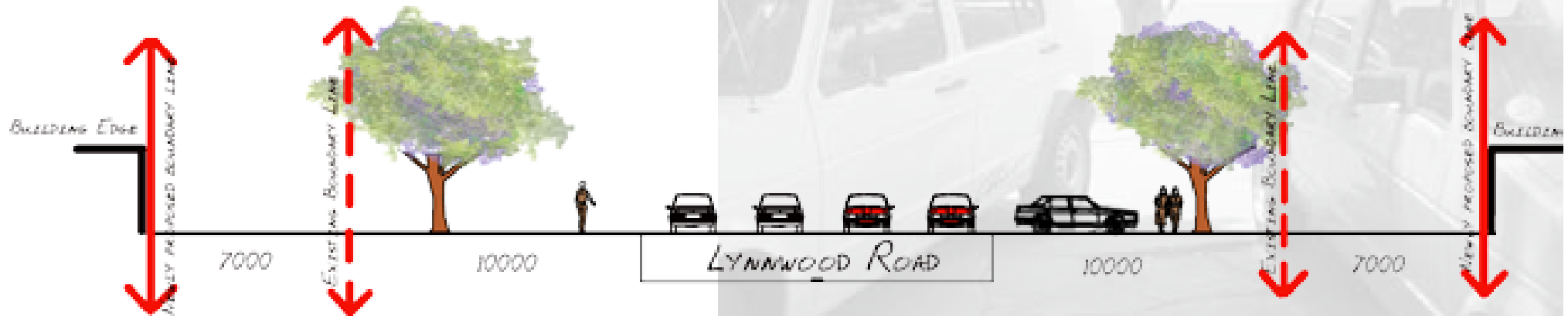

Fig. 6.25 Modification of boundary lines along Lynnwood Road.





## The Stramp

A stramp will form the northern edge of the square. The main purpose of the stramp is to ease the flow of circulation into and from South Campus. The newly proposed parkade and art and architecture intervention will have access from the stramp.

- Corners of University and Lynnwood Road

As the new BRT stops will be situated on these edges a proposal has been made for a series of **earth mounds** which will form part of the green corridor extending from Magnolia Dell. This has led to the decision to close the vehicular service gate along Lynnwood Road. This will have no influence on the traffic circulation on Main Campus as this gate is presently permanently locked.

- The service road

A service road will be built over the existing channel. The road will be accessible from University Road, it will provide a secondary entrance and primary exit to and from the parkade. This road will also be used by delivery trucks to service buildings.

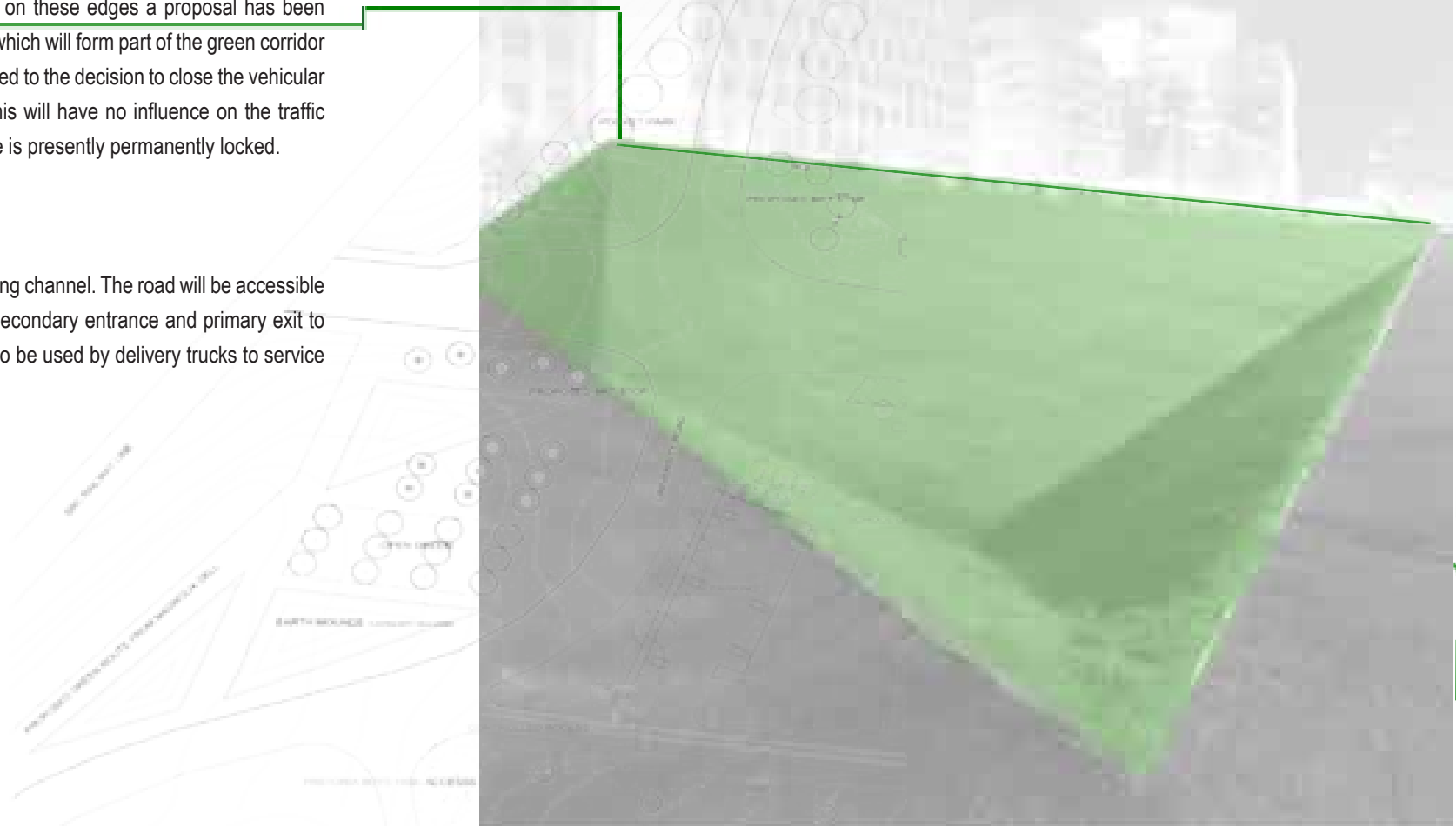

Fig. 6.26 Earth mound.

## Materials

- Timber decking

Timber decking material is used in close proximity of open water or it serves as an edge between water and hard surfaces. It was also considered as a favourable material as it has a low embodied energy.

- Cobble stones
- Permeable concrete paving

The in situ laid permeable concrete paving will cover most of the hard surfaces; this offers a method for on site infiltration and combines surface stability with permeability. The series of voids helps to reduce both runoff volume, the concentration of overland flow and allows air to filter through, thus water is directed into the groundwater recharge.

The light colour of the concrete increases the material's albedo performance and reduces its heat absorption capacity, thus creating a more favourable micro climate and reducing heat islands effects, especially during summer months.

Pervious concrete help protect the trees in paved areas as air and water are able to get to tree roots.

(Thompson, J.W. & Sorvig, K. 2000)  
([www.perviuospavement.org](http://www.perviuospavement.org))

- Natural stone finishes.

The vertical edges of all steps, retaining walls and free standing walls will be consist of natural stone finish. The stone, if possible, should be salvaged from a source close to the site.

- Existing concrete

Large parts of the site consist of in situ concrete and precast concrete blocks. Some of the existing concrete is arranged into a new pattern of paving, interspersed with planting. This technique reduces the demolition debris which would end up on landfills.

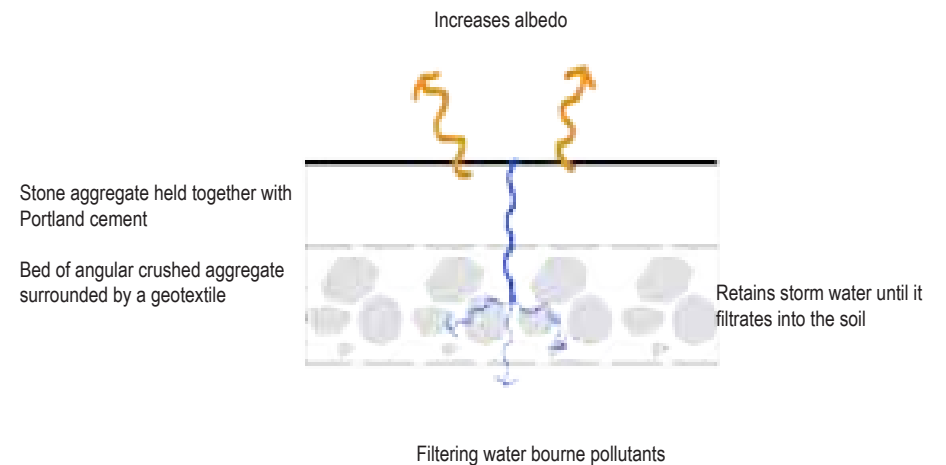

Fig. 6.27 Functioning of pervious concrete.

Concrete's extensive use as a building material means that it is a good candidate for reuse. The only potential for in situ concrete is to crush it and to use it directly for either fill or landscaping.

Existing pre cast concrete blocks can be used in the construction of new buildings including roof tiles, concrete lintels and kerb edgings.

(Addis, B.2007.)



Fig. 6.28 Combination of materials used on site.

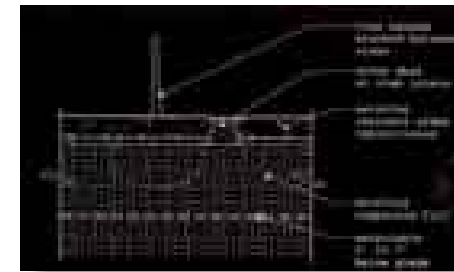
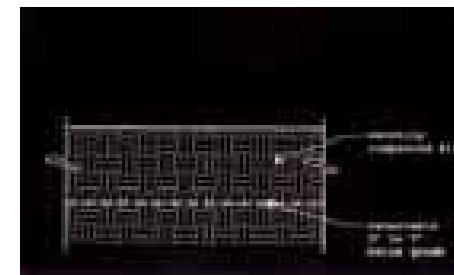
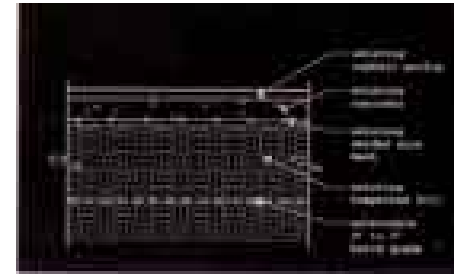

Fig. 6.29 – 6.31 Sections showing the sequence of the construction in process.



SYSTEMS

# VEGETATION

LOW MAINTENANCE PERENNIAL PLANTING  
LUZ LANDSCHAFTSARCHITEKTEN  
RIEM LANDSCAPE PARK

The principle of “leading aspect” provides the main foundation for successful design with plantings.

The leading aspect occurs 2- 4 times/ m<sup>2</sup>

A few species dominate in every plant grouping

Dominant establishment and self propagation maintain a design vision over time

The planting effect is exhibiting a dynamic character

*(Margolis, L & Robinson, A.2007.)*



Fig. 6.34 Mulching of plantings.



Fig. 6.32 Shrub meadow.



Fig.6.33 Distribution of topsoil.

## Systems

### Vegetation

The site vegetation will be a representation of the four, most diverse vegetation types found in the Bankenveld biome. (Bredenkamp, G.J. 2003). Each vegetation type will form its own ecosystem.

The aim of the site's vegetation is to illustrate the temporal quality of landscape, making visible the change and movement inherent in the medium.

Vegetation, where possible, will be established through self propagation and succession. This will be managed by the newly propose Earth Centre and the Green House on the façade of Lynnwood Road. Plants species will be selected for their attractions to wildlife and physical form.

Each vegetation type should be perceived to be uniform on a large scale with variety on a small scale. The principle dictates dominant species in each plant grouping which creates the "leading aspect" of the vegetation image. The dominant species should occur 2 – 4 times per square meter with companions every square metre or even every 2- 4 square meters.

The vegetation types:

- River Drainage
- Grassland
- Rocky dry exposed slope
- Mountain kloof

### Managed succession

Stage 1: Establishment pioneer and climax species (mixed)



Stage 2: Canopy closure and thinning

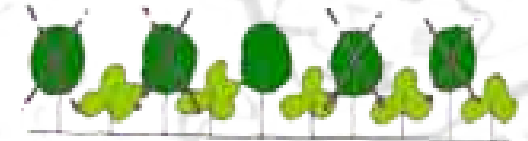

Stage 3: Onward mature climax



Fig. 6.36 Managed succession.

Fig. 6.35 Topographical section.

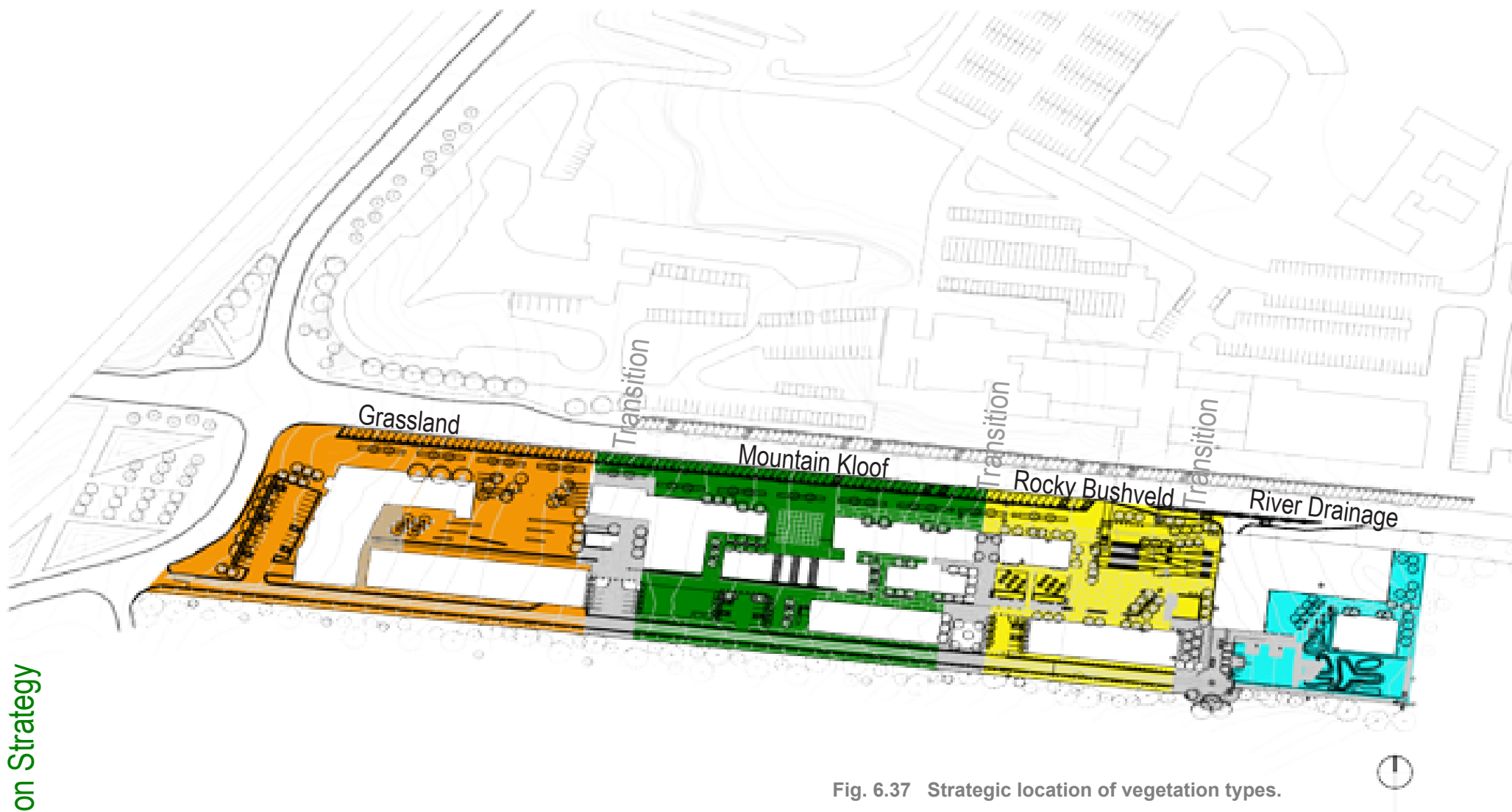

Fig. 6.37 Strategic location of vegetation types.





## GRASSLAND

Grasses	Botanical name	Common name	Height (m)	Links with animals and insects
	<i>Themeda triandra</i>	Red grass	0.3 - 1	Birds use grass to make their nests.
	<i>Cymbopogon plurinodis</i>	Narrow leaf turpentine grass	0.5 - 1.7	Seed eating birds play an important role in the dispersal of these seeds.
	<i>Eragrostis curvula</i>	Weeping love grass	0.3 - 1.2	Many insect species use grasses for food as well as shelter.
	<i>Heteropogon contortus</i>	Spear Grass	0.2 - 1	
	<i>Aristida congesta</i>	Tassel three – awn	0.3 - 0.9	
	<i>Hyperhemia hirta</i>	Common thatch grass	0.3 - 1.5	
	<i>(van Oudtshoorn, F. 2006.)</i>			

Shrubs	Botanical name	Common name	Height (m)	Links with animals and insects
	<i>Mundulea sericea</i>	Cork bush	2 - 5	Two specie of butterfly (Natal Barred Blue, Common Blue) breed on this tree.
	<i>Vungueria infausta</i>	Velvet wild meddler	2 - 8	The leaves are eaten by bush babies and squirrels. The flowers are visited by butterflies.
	<i>Zanthoxylum capense</i>	Small knobwood	4 - 7	Mouse birds and barbets eat the fruit.
	<i>Ehretia rigida</i>	Puzzle bush	2 - 4	Fruit are favoured by most birds
	<i>Grewia flava</i>	Velvet raisin	1 - 4	

Trees	Botanical name	Common name	Height (m)	Links with animals
	<i>Ziziphus mucronata</i>	Buffalo thorn	3 - 10	The larvae of many butterfly feed on this tree. The fruit are eaten by the Green Pigeon.
	<i>Acacia karroo</i>	Sweet thorn acacia	4 - 15	Many bird and insects are attracted to the flowers. Roots increase the fertility of the soil.
	<i>Rhus pyroides</i>	Fire – thorn karee	2 - 9	Fruit is eaten by birds such as starlings.
	<i>Acacia robusta</i>	Brack thorn acacia	8 - 15	Flowers attract bees and butterflies.

Flowering Time

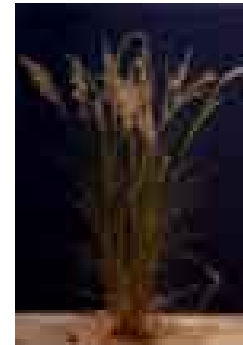
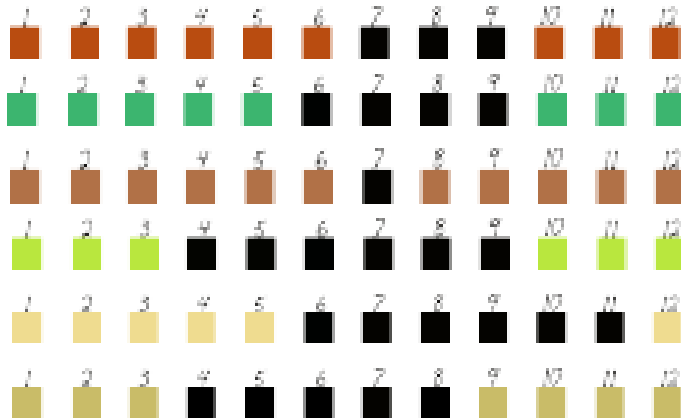

Fig. 6.38 Tassel Three awn (*Aristida congesta*).

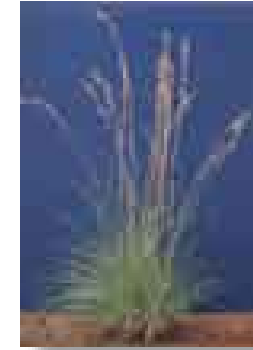

Fig. 6.39 Narrow leaved turpentine grass.



Fig. 6.40 Spear grass (*Heteropogon contortus*).

Flowering Time

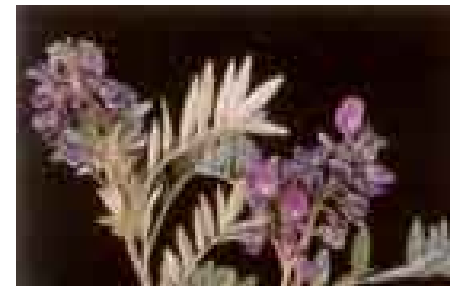
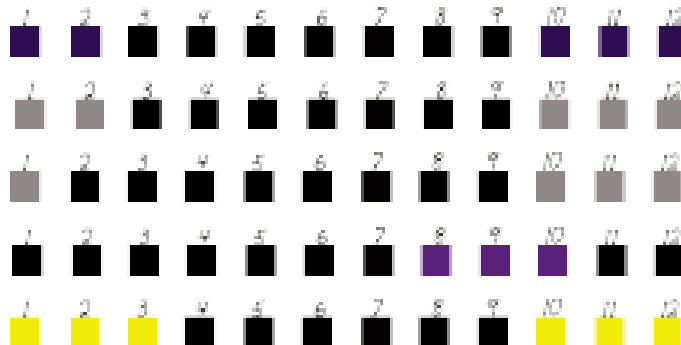

Fig. 6.41 Cork bush (*Mundulea sericea*)

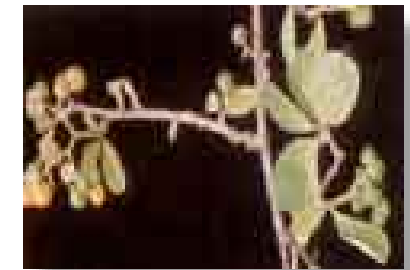

Fig. 6.42 Puzzle bush (*Ehretia rigida*) fruit.

Flowering Time



Fig. 6.43 Brack thorn (*Acacia robusta*) flowers.



Fig. 6.44 Buffalo thorn (*Ziziphus mucronata*) fruit.

(Thomas, V. & Grant, R. 2002.)

## MOUNTAIN KLOOF

Shrubs	Botanical name	Common name	Height (m)	Links with animals
	<i>Dodonea angustifolia</i>	Sand olive	2 – 4	Birds such as bulbuls and mousebirds eat the fruit. Fruit are eaten by the speckled mousebird.
	<i>Carissa bispinosa</i>	Forest num – num	1 – 4	
	<i>Grewia oxidentalis</i>	Crossberry raisin	2 - 6	
Trees	Botanical name	Common name	Height (m)	Links with animals
	<i>Podocarpus falcatus</i>	Small – leaved yellowwood	10 - 30	The female cones are eaten by pigeons and bats.
	<i>Olea europaea</i>	African olive	2 - 10	The fruit is eaten by birds such as Pied starlings and Rameron Pigeons.
	<i>Pappea capensis</i>	Jacket – plum	4 - 10	Fruit is eaten by a wide variety of birds particularly Green Pigeons



Fig. 6.45 Small leaved yellowwood (*Podocarpus falcatus*) fruit.

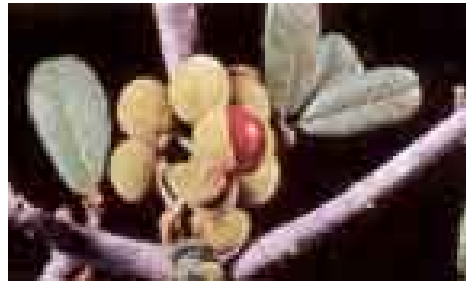

Fig. 6.46 Jacket plum (*Pappea capensis*) fruit.

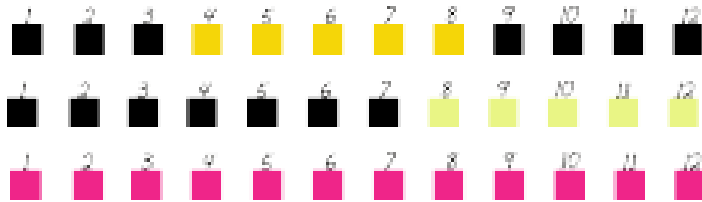

Fig. 6.47 Jacket plum (*Pappea capensis*) flowers.



Fig. 6.48 African olive (*Olea europaea*) flowers.

Flowering Time



Flowering Time

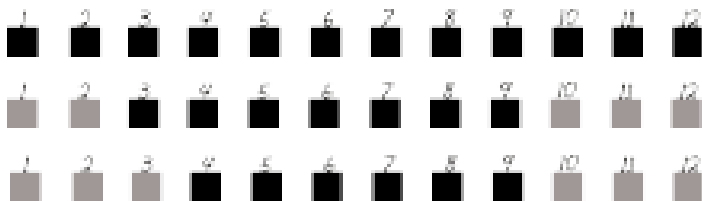

Fig. 6.52 Cross berry raisin (*Grewia occidentalis*) flowers.

(van Wyk, P & van Wyk, B.1997.)

(Thomas, V. & Grant, R. 2002.)



Fig. 6.49 Forest num – num (*Carissa bispinosa*) flowers.

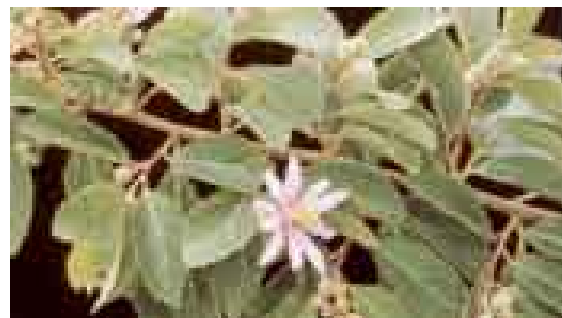

Fig. 6.50 Cross berry raisin (*Grewia occidentalis*) flowers.



Fig. 6.51 Forest num – num (*Carissa bispinosa*) fruit.

## ROCKY BUSHVELD

### Grasses

Botanical name	Common name	Height (m)	Links with animals
<i>Aristida Stipitata</i>	Long awned grass	0.2 – 1.5	Birds use grass to make their nests. Seed eating birds play an important role in the dispersal of these seeds. Many insect species use grasses for food as well as shelter.

### Shrubs

Botanical name	Common name	Height (m)	Links with animals
<i>Rhamnus prinoides</i>	Dogwood	2 - 7	The flowers attract bees while the fruit is eaten by fruit eating birds such as mousebirds.
<i>Diospyros lycioides</i>	Bluebush	2 - 7	The hanging growth of the tree makes it a good hiding place for animals

### Trees

Botanical name	Common name	Height (m)	Links with animals
<i>Acacia caffra</i>	Common hook thorn acacia	5 – 10	Good fodder tree
<i>Rhus lancea</i>	Karree	4 - 9	Bulbuls and francolins eat the ripe fruit
<i>Rhus dentate</i>	Nana – berry	1 - 6	Fruit is eaten by bulbuls and guineafowl
<i>Aloe marlothii</i>	Mountain aloe	2 - 6	Sunbirds and weavers feed on the nectar rich flowers
<i>Leucosidea sericea</i>	Oldwood	1 - 9	Not applicable in urban areas
<i>Diospyros whyteana</i>	Bladdernut	2 - 5	Not applicable in urban areas
<i>Celtis Africana</i>	White stinkwood	7 - 12	Not applicable in urban areas
<i>Olea europaea</i>	African olive	2 - 10	The fruit is eaten by pied starlings and Green pigeons
<i>Acacia xanthophloea</i>	Fever tree	5 - 12	Not applicable in urban areas
<i>Cussonia paniculata</i>	Highveld cabbage tree	4 - 6	Good fodder tree

(van Wyk, P & van Wyk, B.1997.)

(Thomas, V. & Grant, R. 2002.)

Flowering time



Fig. 6.56 Long awned grass. (*Aristida stipulate*)



Flowering time

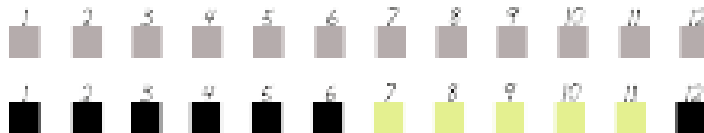

Fig. 6.55 Fever tree (*Acacia xanthophloea*) fruit.



Flowering time

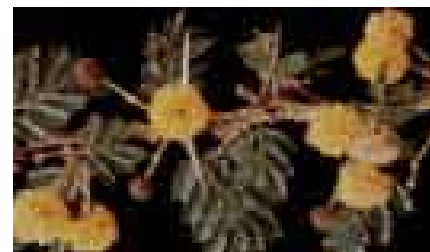
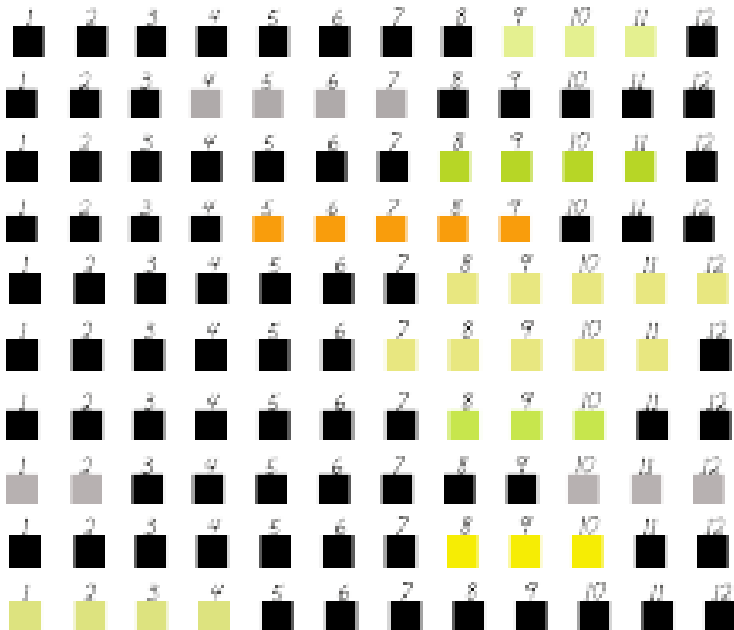

Fig. 6.53 Fever tree (*Acacia xanthophloea*) flowers.

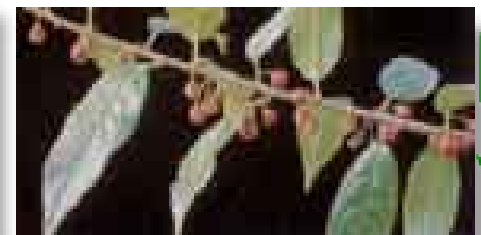

Fig. 6.54 Dogwood (*Rhamnus prinoides*) fruit.

## RIVER DRAINAGE

### Shrubs

Botanical name	Common name	Height (m)	Links with animals
<i>Rhoicissus tridentata</i>	Cape Bushmen's grape	Creeper	The fruit is eaten by birds.
<i>Grewia occidentalis</i>	Crossberry raisin	2 - 6	The fruit is eaten by the speckled mousebird.

### Trees

Botanical name	Common name	Height (m)	Links with animals
<i>Celtis africana</i>	White stinkwood	7 - 12	Not applicable in urban areas
<i>Combretum erythrophyllum</i>	River bushwillow	5 - 15	Fruit is eaten by pied barbets

### Wetland species

Botanical name	Common name
<i>Berula erecta</i>	Taro
<i>Colocasia esculanta</i>	Papyrus
<i>Cyperus papyrus</i>	Dwarf papyrus
<i>Cyperus prolifer</i>	
<i>Cyperus textilis</i>	Red hot poker
<i>Kniphofia sp.</i>	Waterweed
<i>Lagarosiphon major</i>	
<i>Ludwigia adscandens</i>	Blue lotus
<i>Nymphaea caerulea</i>	
<i>Nymphoides indica</i>	
<i>Nymphoides thunburgiana</i>	Common reed
<i>Phragmites australis</i>	
<i>Potamogeton pectinatus</i>	
<i>Schoenoplectus corymbosus</i>	Bullrush
<i>Typha capensis</i>	Cape Reedmace
<i>Aponogeton distachyos</i>	Water hawthorn

Flowering time

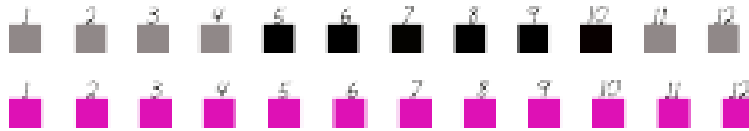

Flowering time

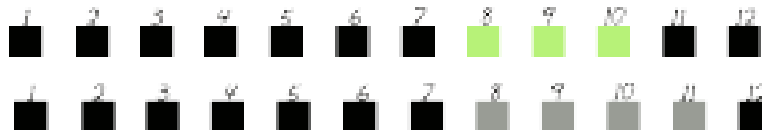

Fig. 6.60 Cross berry raisin (*Grewia occidentalis*) flowers.

(Thomas, V. & Grant, R. 2002.)



Fig. 6.57 River bushwillow (*Combretum erythrophyllum*)



Fig. 6.58 Cross berry raisin (*Grewia occidentalis*) fruit.

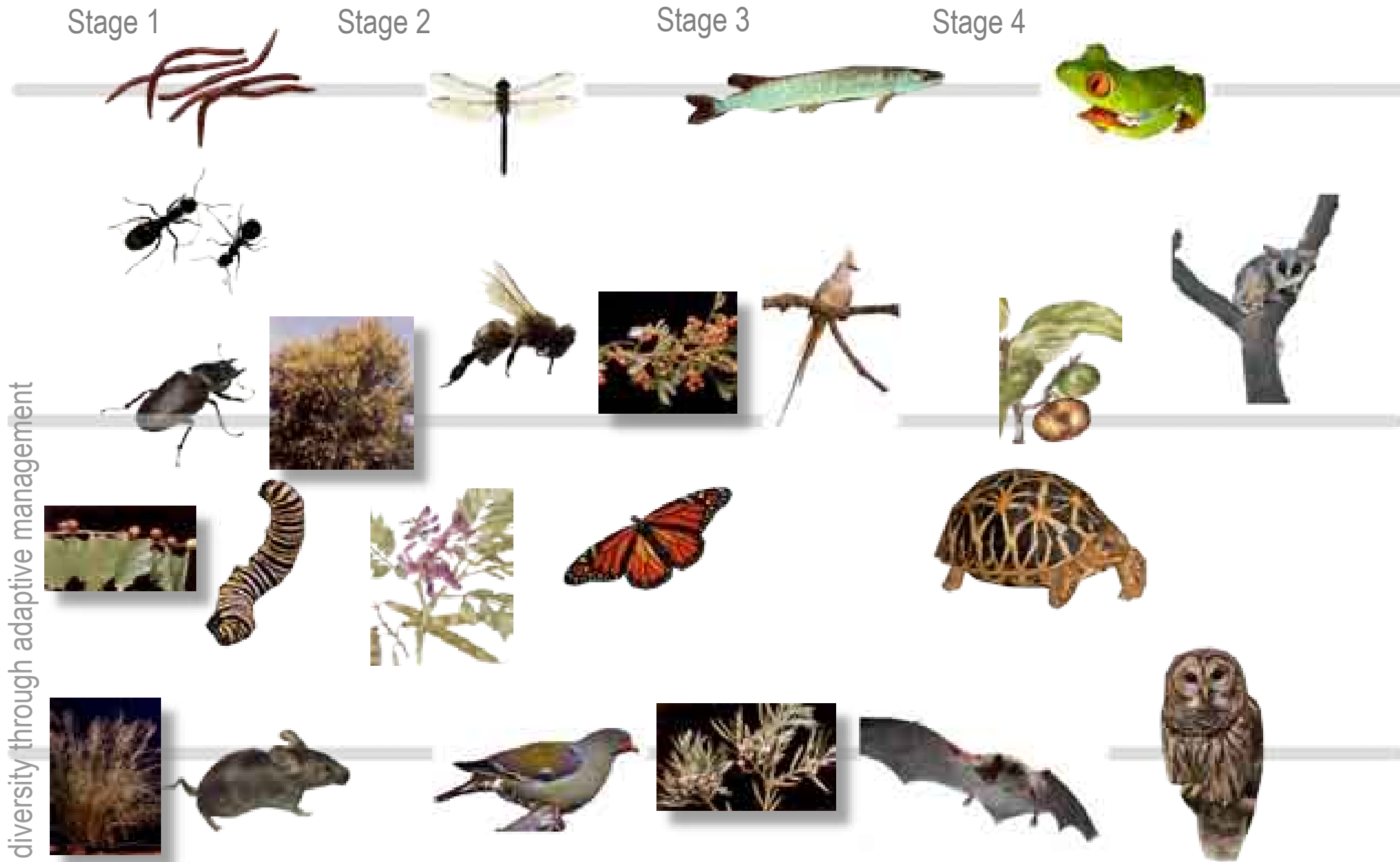

Fig. 6.59 Bushman's grape (*Rhoicissus tridentate*) fruit.



6

WILDLIFE



Specie diversity through adaptive management

Fig. 6.61 Specie Diversity





SOIL

## Soil

Decomposers and detritivores are important in the formation of soils, especially in urban environments. Earthworms aerate, till and fertilize the soil, breaking down organic waste into plant available forms. This improves the soil structure and nutrient and water holding qualities of soil. Organic waste, produced by humans, can to some extent be used in the process of soil restoration. The goal of soil restoration is to produce a soil with chemistry and fertility similar to those found in healthy regional soils.

([www.globalwarming.co.za](http://www.globalwarming.co.za).)

([www.earth911.org](http://www.earth911.org).)

Soil on the site will be fertilized by earth worms, also known as vermicompost. The worm castings produce odourless compost and help plants to thrive. Worm compost can be harvested within three months.

([www.fullcycle.co.za](http://www.fullcycle.co.za))

Soil enrichment

Organic waste from cafeterias and unused paper from the U.P Press  
(Stale bread, apple cores, orange peels, lettuce trimmings, coffee grounds)



Produces

Placed into worm bins

Vermi compost and liquid organic fertilizer

Fig. 6.62 Phases in vermiculture.

6

HYDROLOGY AND AIR

Hydrology

The hydrological system on the site is not going to significantly enhance the water quality of the hydrological system on a large scale but should rather be seen as an example of how water can be handled on an urban site.

Air

A tree buffer will be planted along the northern edge of the site to decrease air pollution from heavy traffic along Lynnwood Road.



Fig. 6.63 Systemic section through hydrology.

# DESIGN DEVELOPMENT

## Design Development

### Initial design concepts

- Squares

From an urban point of view, the spaces in front of the proposed anchors (refer to figure 6.2) should become public (west) and semi public (east) squares. Due to the positioning of the existing buildings and the newly proposed School of Motion Picture, the northern edge of the western square should form an open window from Lynnwood Road.

The northern edge of the eastern square connects the pedestrian bridge and South Campus. This gave me the opportunity to design a living edge which will also facilitate the physical movement of pedestrians.

- Axis

The axis was important to maintain as this lends the site its distinct character it also physically connects the two squares. As one moves along the axis it becomes an intricate display of daily shadows and yearly seasons.

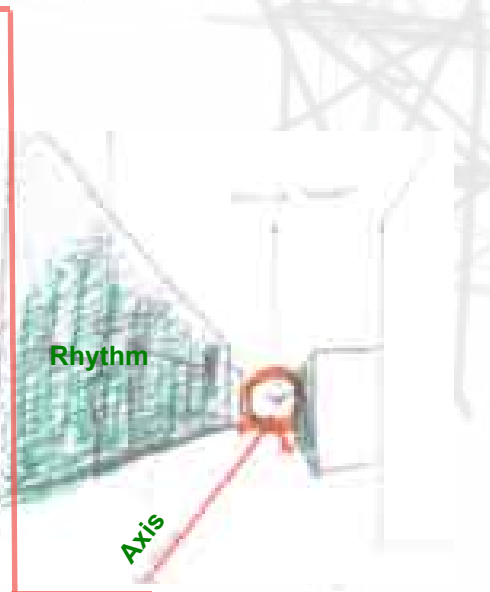
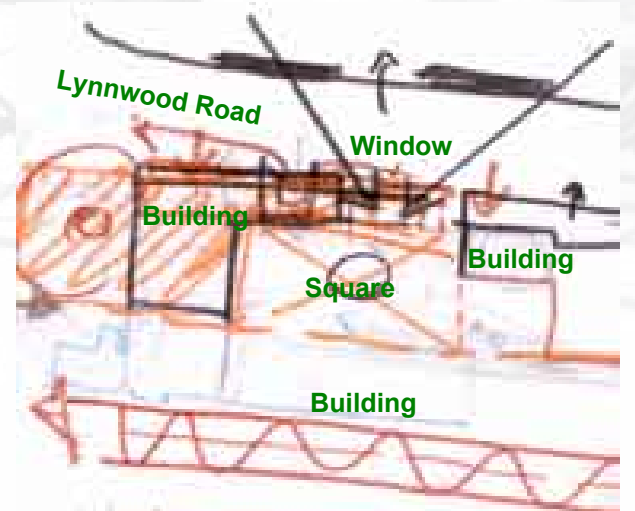
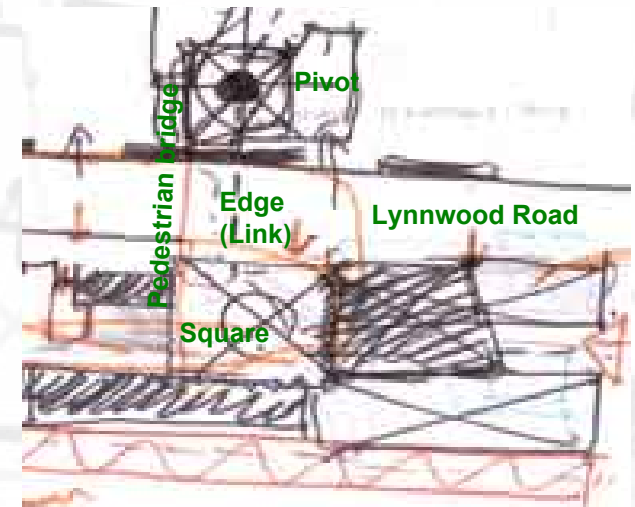

Fig. 6.64 – 6.66 Conceptual diagrams.



- Buildings

Buildings are not seen as barriers but connecting tissue, this enhances the concept of vertical landscapes.

- Linking the biophysical and cultural environment

The visual link between the biophysical and cultural environment are facilitated through the movement of water. The physical transition space between these two environments become important.

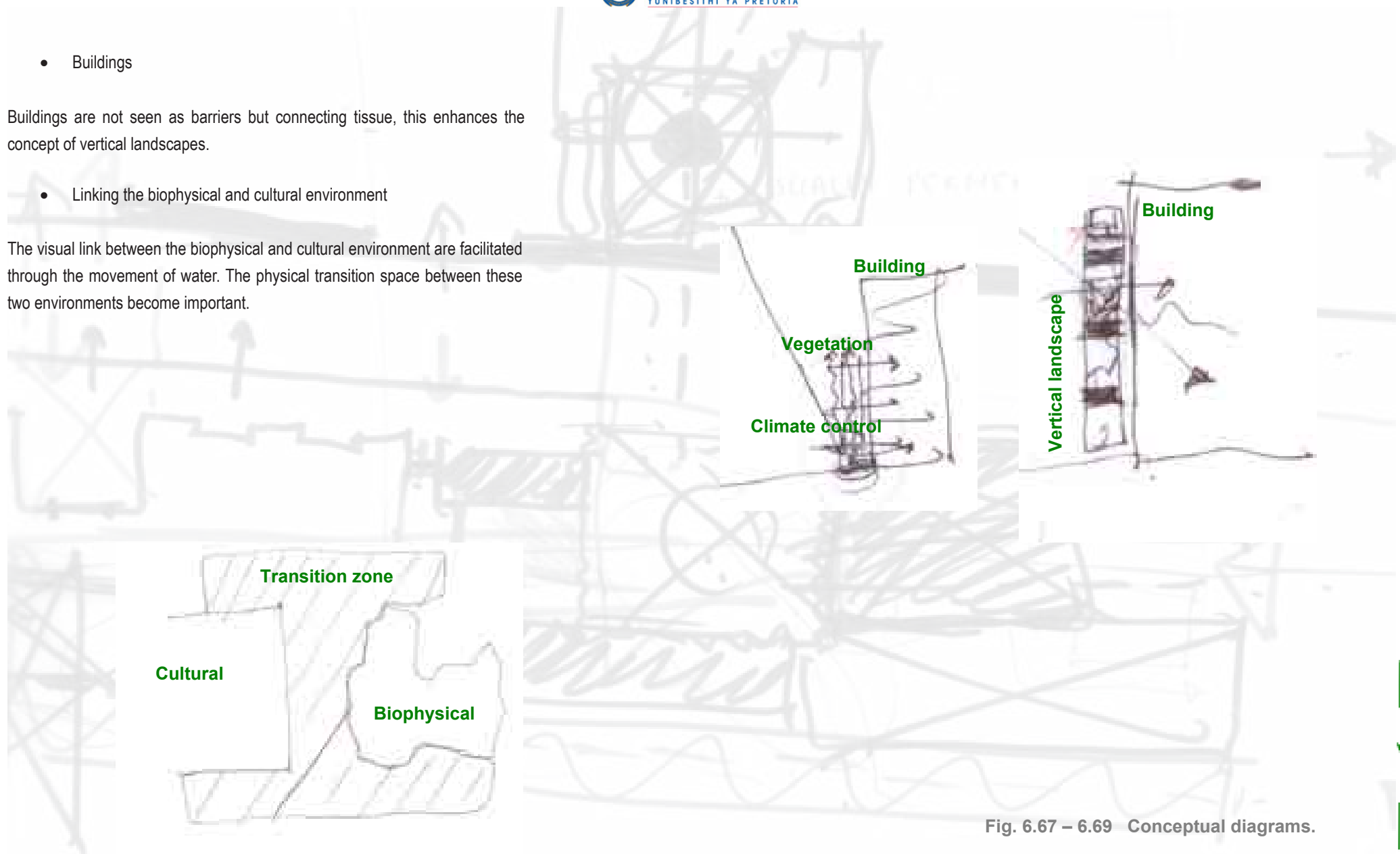

Fig. 6.67 – 6.69 Conceptual diagrams.



SKETCH PLAN

My strategy for the sketch plan was to divide it into layers showing the following:

- Vegetation and soft surfaces
- Hydrology
- Paving and hard surfaces
- Spatial rooms
- Lighting

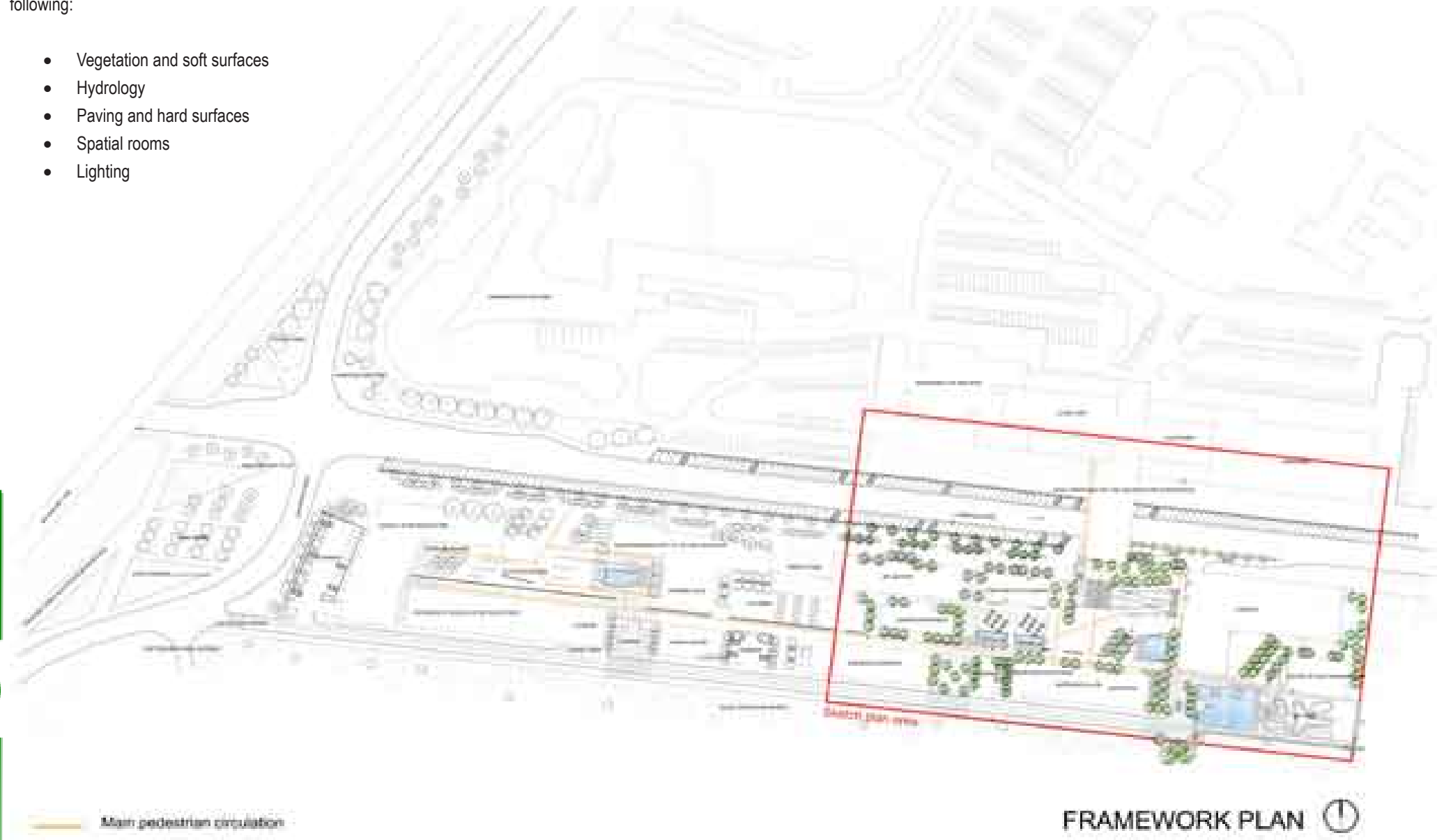

FRAMEWORK PLAN 

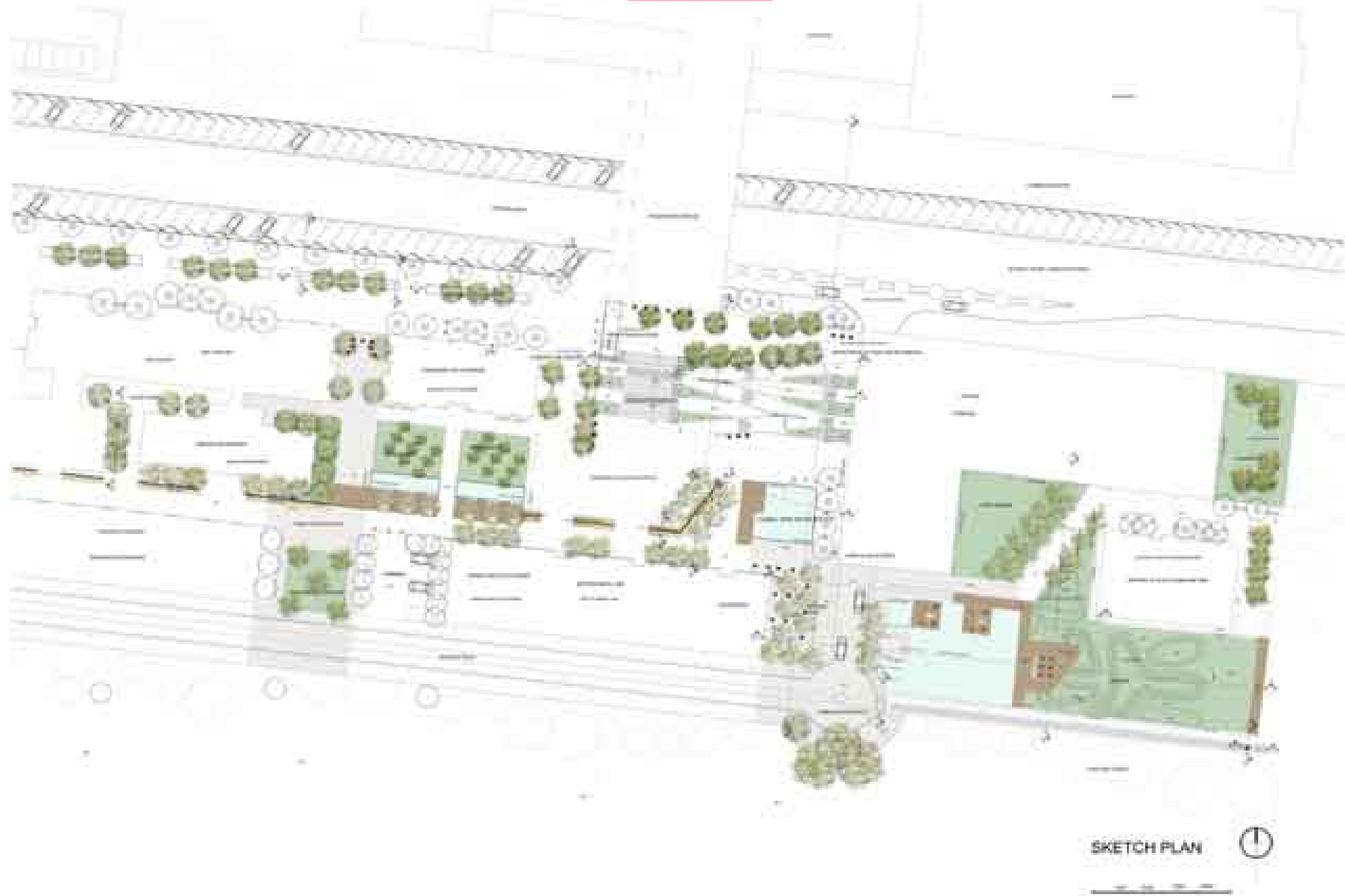

6

LAYERS



**SKETCH PLAN**  
soft surfaces and vegetation

0m 1000m 2000m 3000m



Soft surfaces and vegetation

The largest areas of soft surfaces are located along the eastern and southern side of the parkade. These areas will mainly consist out of lawn with trees. The soft surface on the southern side of the parkade stretches through to the wetland area. The vegetation in the square itself will only consist out of a variety of tree species. The two large soft surfaces in front of the Town and City planning department forms a "front yard" to the building. The physical design of this space has been determined by the symmetrical façade of the building. The soft surfaces on the southern side, (which borders the service road), the green space next to the Drama practice rooms will be an area and the soft areas on the stramp will consist out of rocks at ground level and a variety of shrub and tree species.

12 AM MARCH AFTERNOON

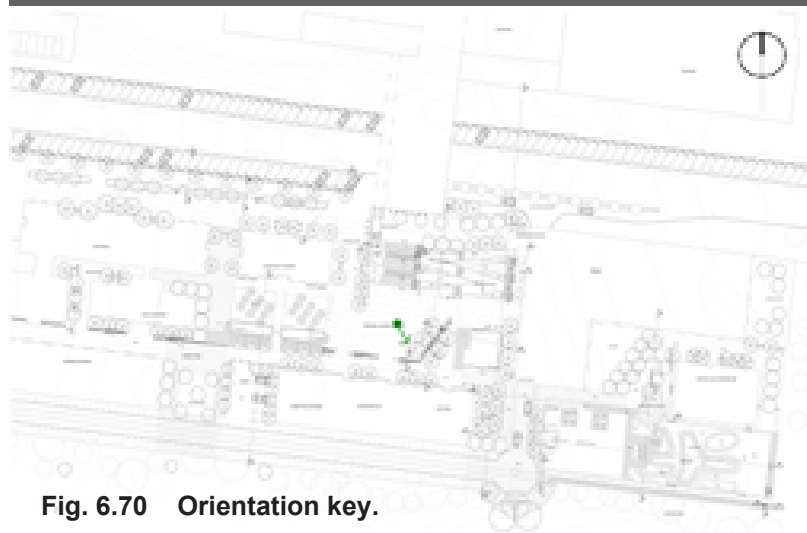

Fig. 6.70 Orientation key.



Fig. 6.71 Space in front of the Drama practice rooms.



12AM JUNE AFTERNOON

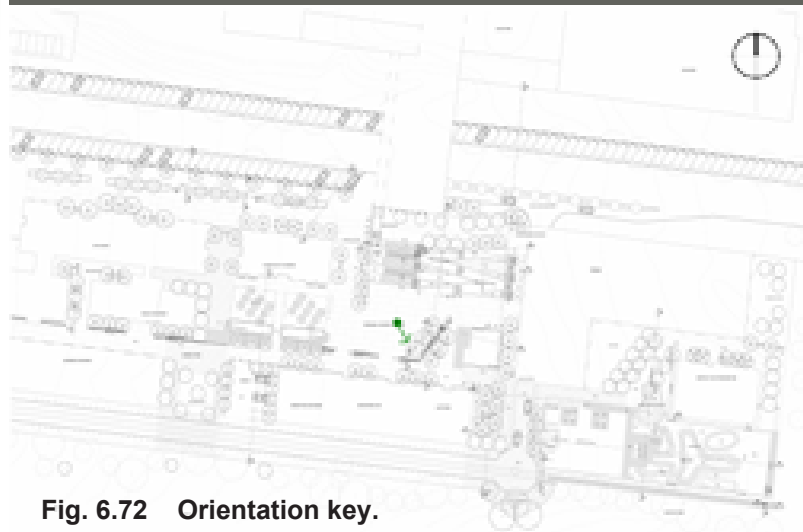

Fig. 6.72 Orientation key.



Fig. 6.73 Boulders.

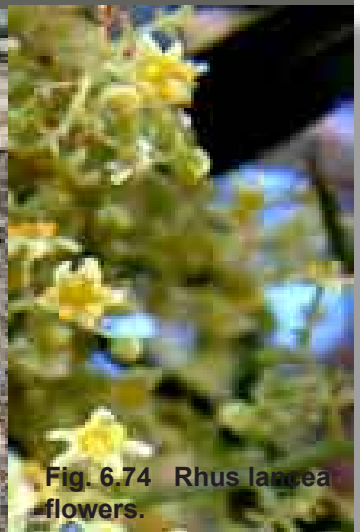

Fig. 6.74 *Rhus lancea* flowers.



Fig. 6.75 Space in front of the Drama practice rooms.

12AM OCTOBER AFTERNOON

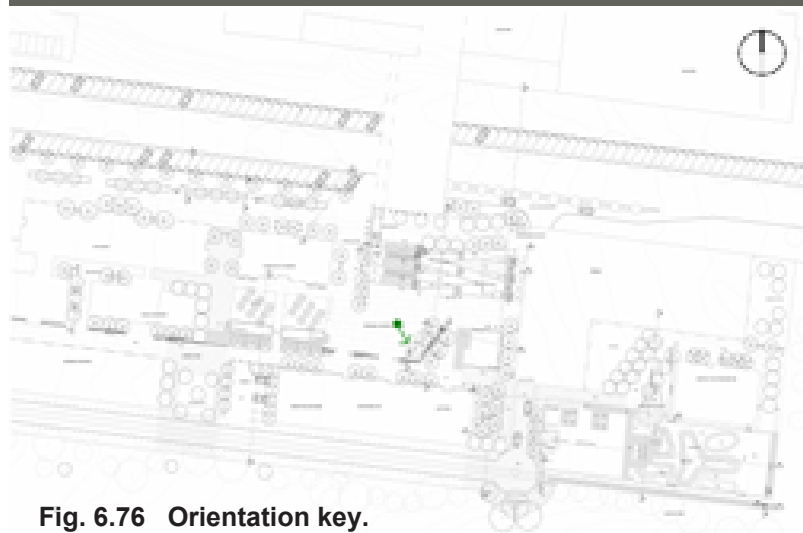

Fig. 6.76 Orientation key.



Fig. 6.77 Water channel.



Fig. 6.78 Water channel.



Fig. 6.79 Space in front of the Drama practice rooms.

## Hydrology

The wetland on the southern side of the site is constructed to cleanse water which is pumped from the channel. (Refer to *Technical Resolution, Wetland system and existing channel*) from there on it flows to the square in more formal shapes. Water ponds are designed in spaces where people will sit, congregate and meet; this allows water to “pause” before being carried away in an open channel until it reaches the end of the system.

# SUMMER MORNING



Fig. 6.80 Orientation key.

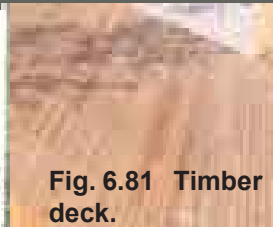

Fig. 6.81 Timber deck.



Fig. 6.82 Wetland species.



Fig. 6.83 Tree top view.

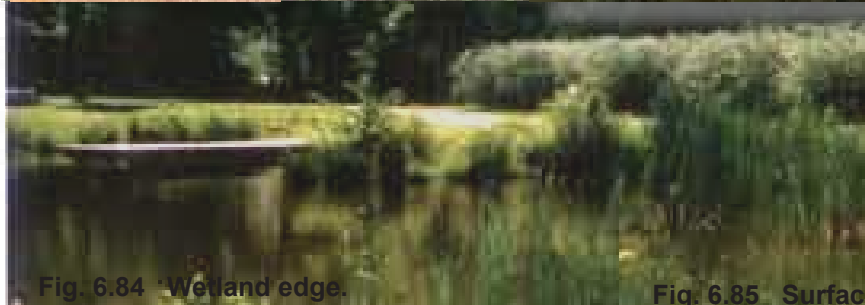

Fig. 6.84 Wetland edge.

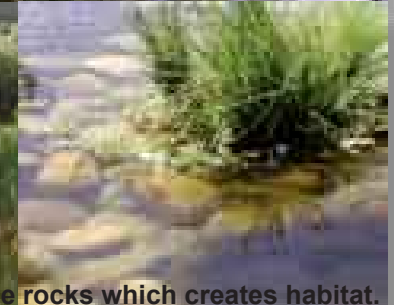
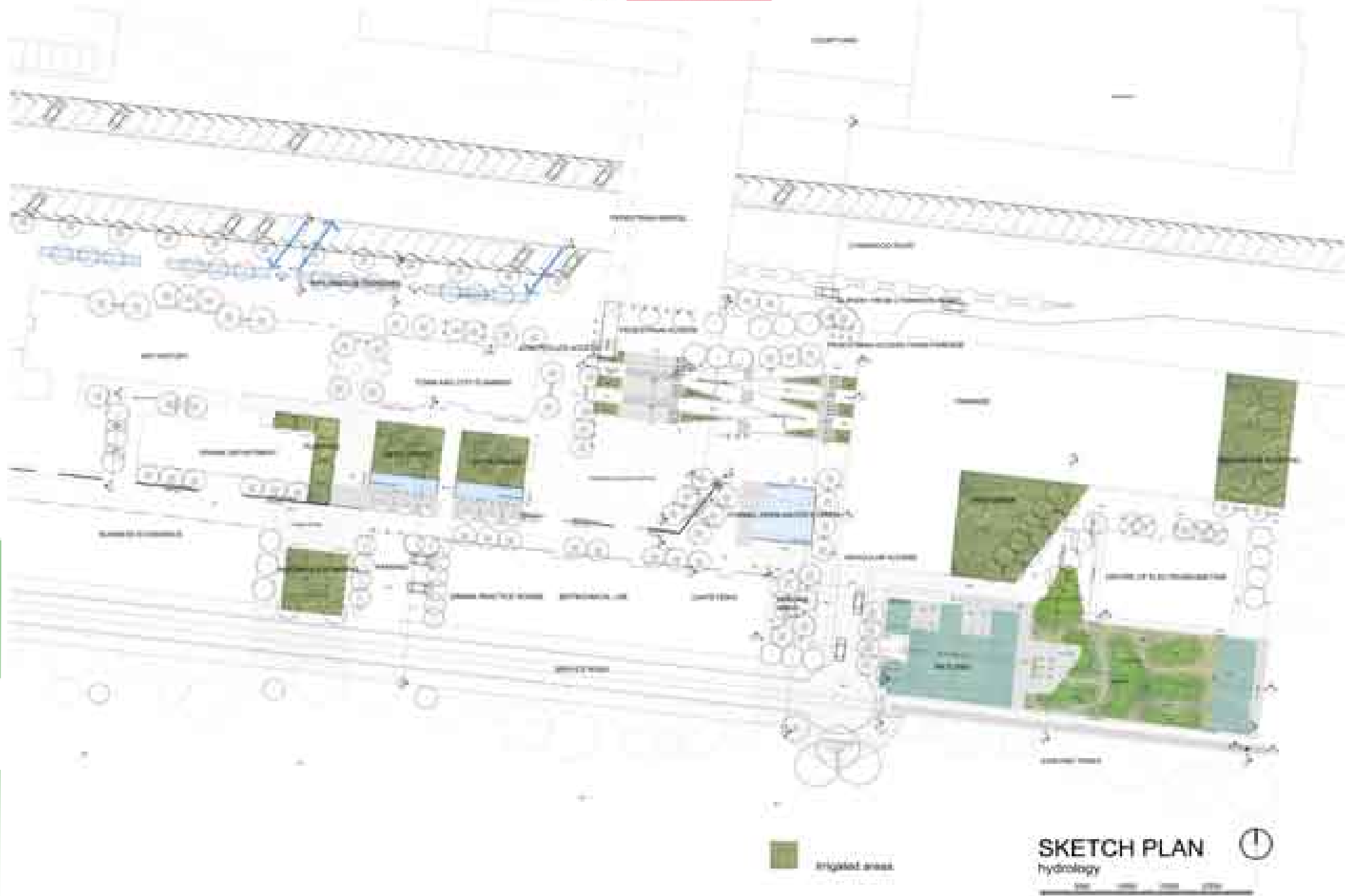

Fig. 6.85 Surface rocks which creates habitat.



Fig. 6.86 Western view from the wetland.





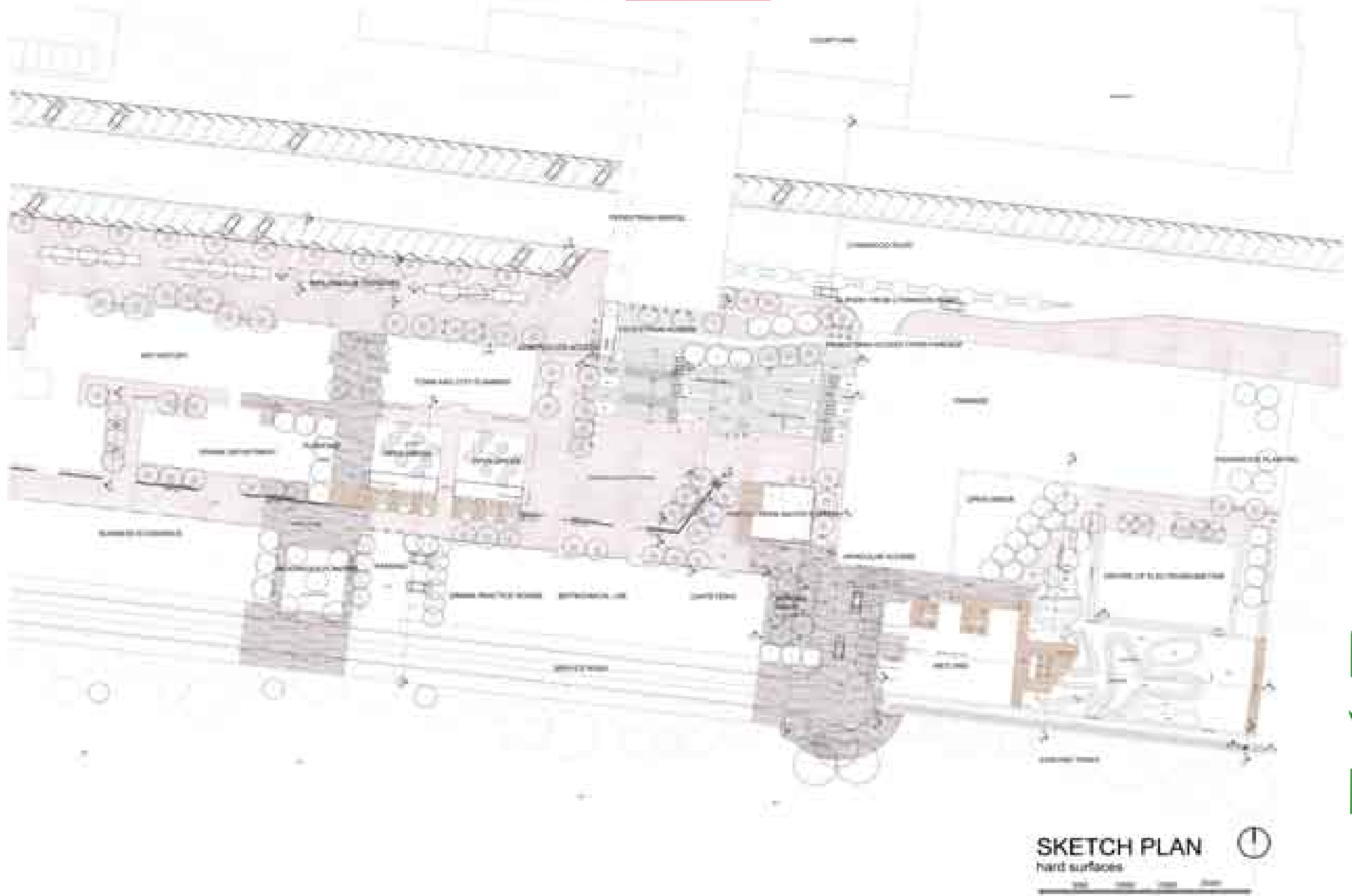



### Paving and hard surfaces

The largest areas on the site will consist out of permeable concrete. Cobble stones will form the surface treatment at transition areas, these transition spaces are identified through a physical change in level or a change in vegetation type. Timber decking is used as it defines the space and forms a strong contrast between the concrete and cobble stone surface material.

9 AM FEBRUARY MORNING

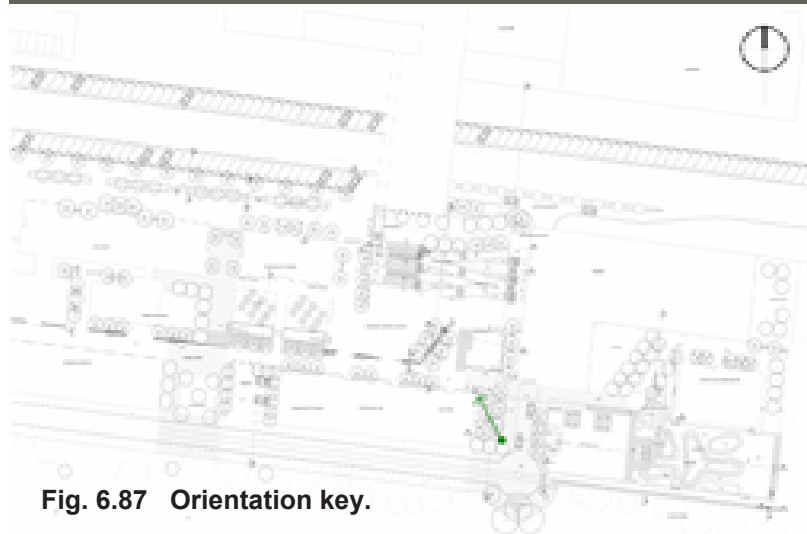

Fig. 6.87 Orientation key.



Fig. 6.88 Seating blocks.

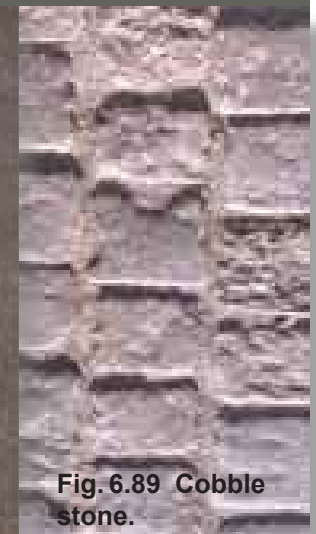

Fig. 6.89 Cobble stone.



Fig. 6.90 Space next to the cafeteria.

1 PM FEBRUARY AFTERNOON

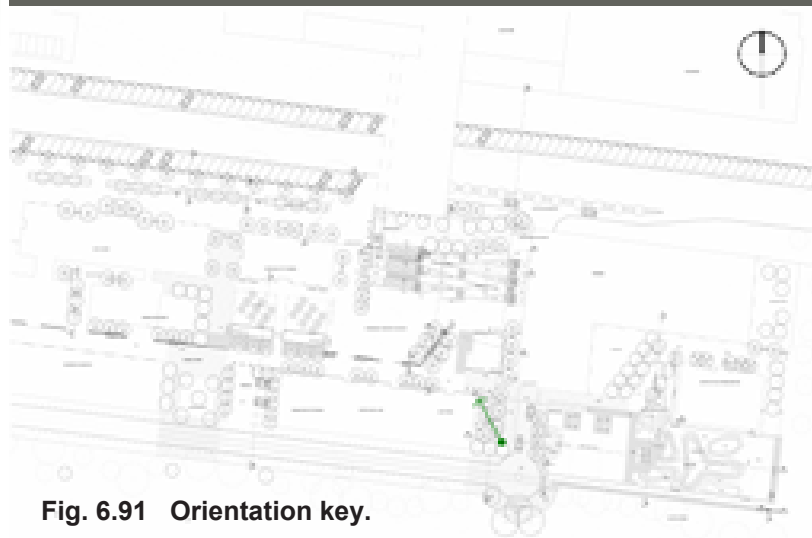

Fig. 6.91 Orientation key.

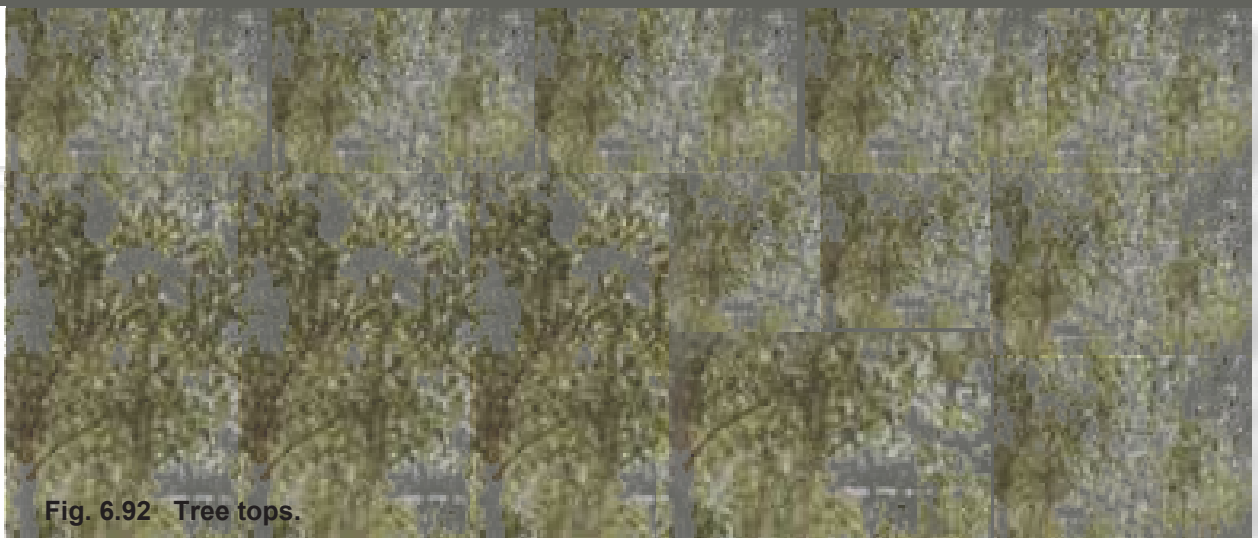

Fig. 6.92 Tree tops.



Fig. 6.93 Space next to cafeteria.



5 PM FEBRUARY AFTERNOON

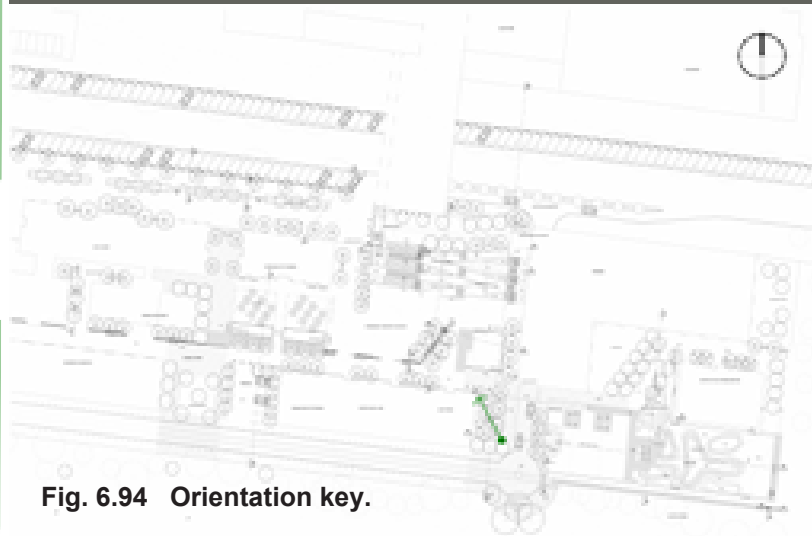

Fig. 6.94 Orientation key.

Fig. 6.95 Tree shadows.

Fig. 6.96 Bollards.





Fig. 6.97 Space next to the cafeteria.



### Spatial rooms

Different spatial rooms were allocated in conjunction with the main site circulation and site activities. Each room will have a specific spatial quality and character which is made up out of the tree canopy, surface material, physical form and adjacent activities.

1 PM SUMMER AFTERNOON



Fig. 6.98 Orientation key.



Fig. 6.99 View through tree canopies.



Fig. 6.100 View towards Town and City Planning.





1 PM WINTER AFTERNOON

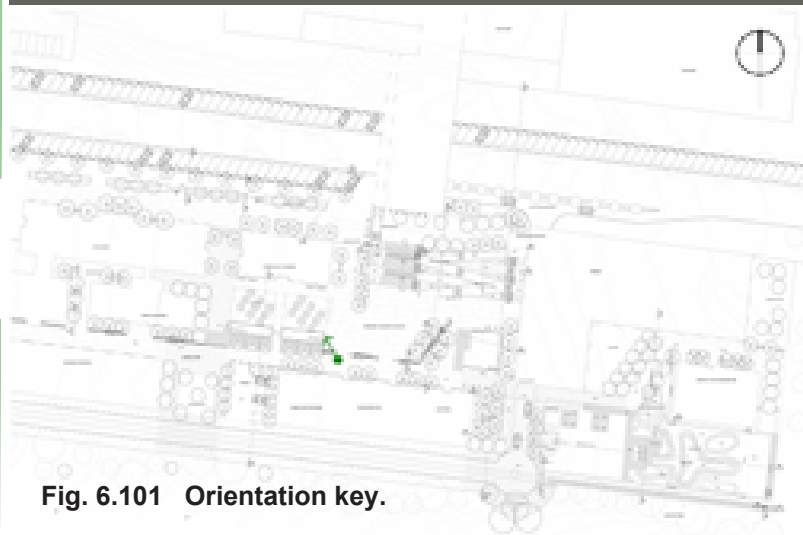

Fig. 6.101 Orientation key.

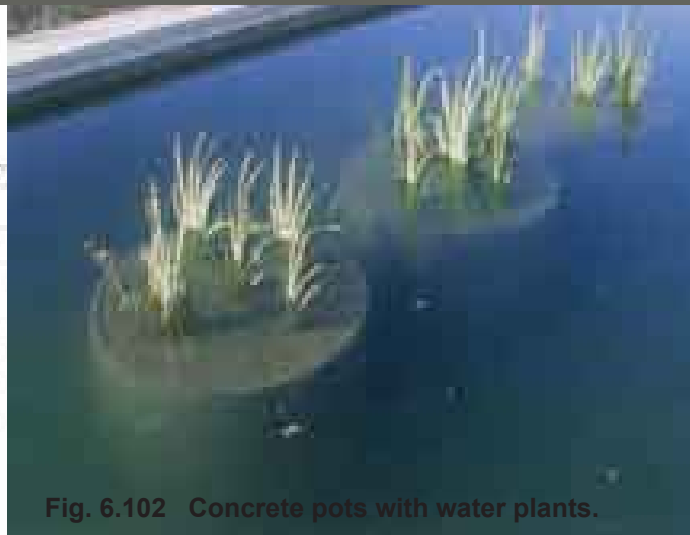

Fig. 6.102 Concrete pots with water plants.



Fig. 6.103 Concrete seating rings.

Fig. 6.104 Grass and water interface.



Fig. 6.105 View towards Town and City Planning.



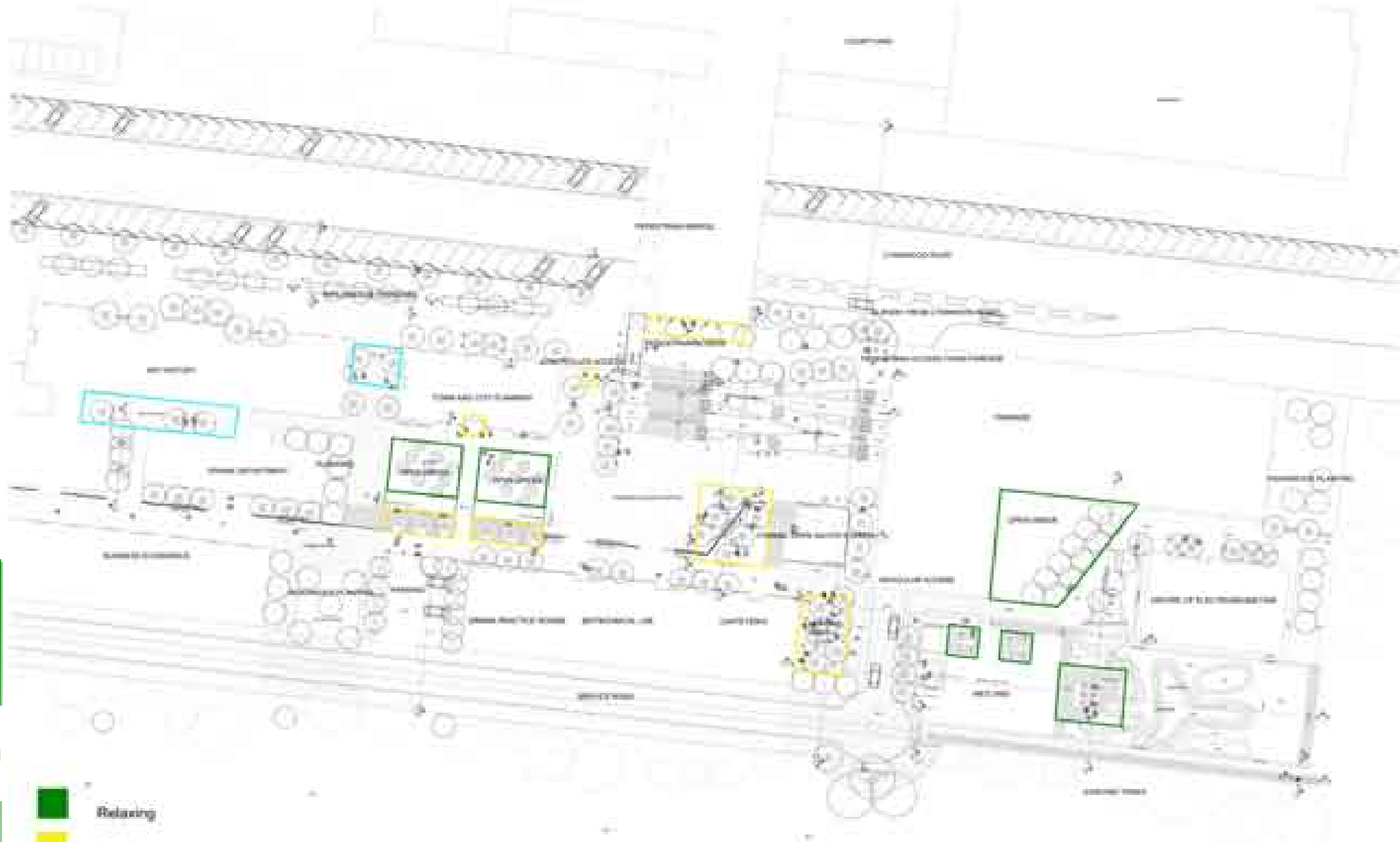

- Relaxing
- Gathering
- Studying and Reading

SKETCH PLAN  
spatial rooms

6

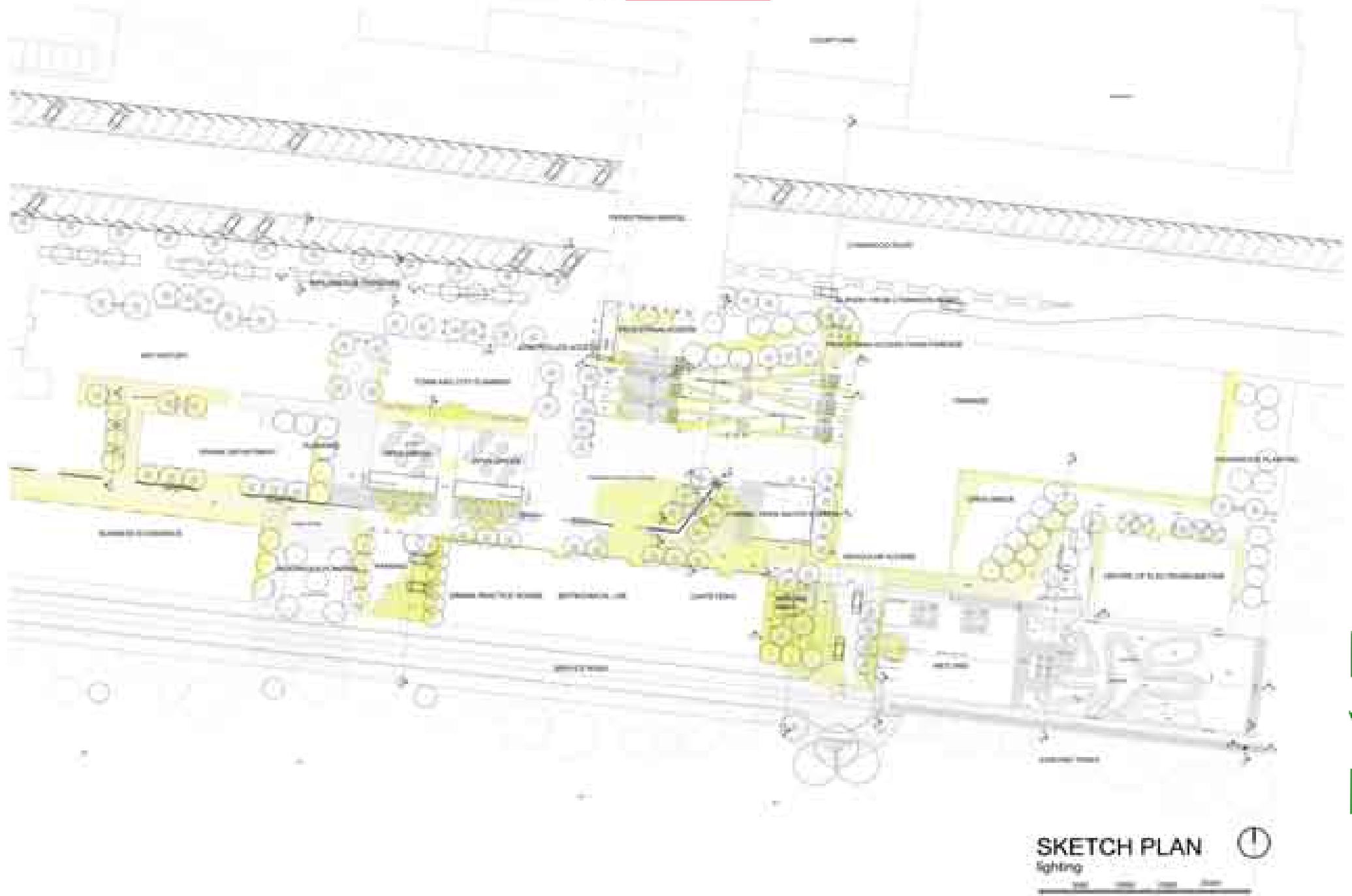

Lighting

Lighting during the night is mainly concentrated around major spaces, the stramp and axis running through the site.

DAY

Fig. 6.106 Aloe marlothii.

Fig. 6.107 Stone wall.

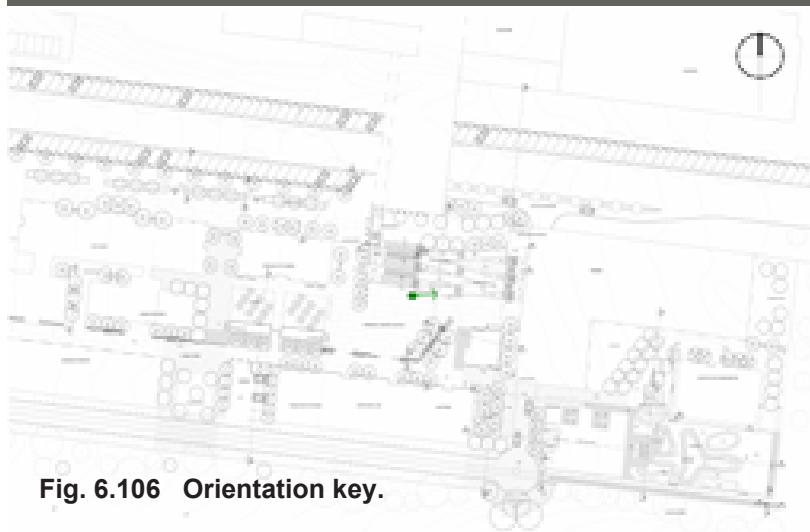

Fig. 6.106 Orientation key.





Fig. 6.109 Ramp access.

NIGHT

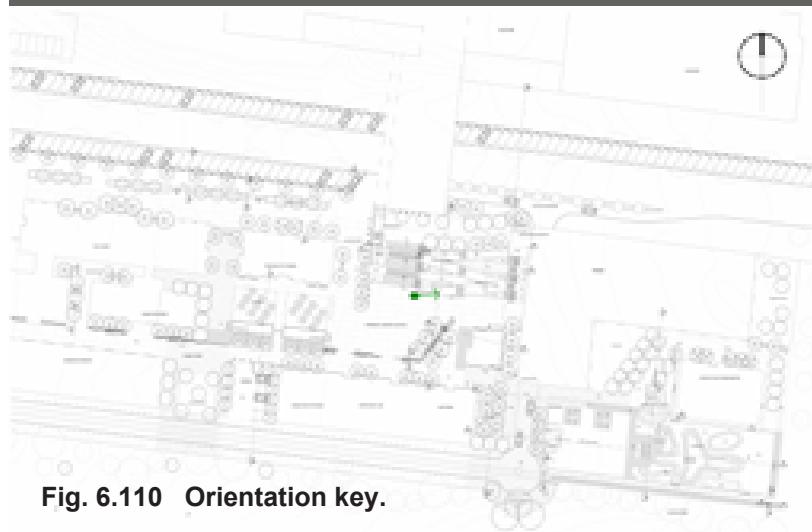

Fig. 6.110 Orientation key.

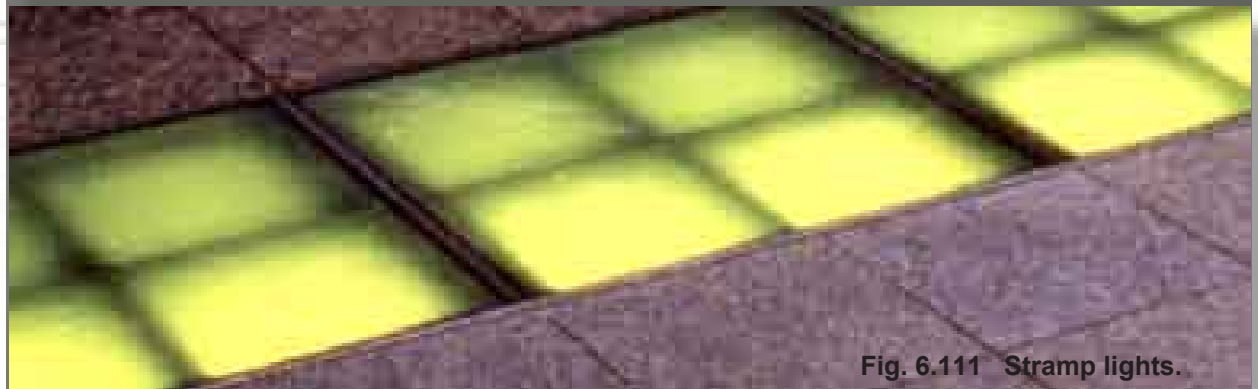

Fig. 6.111 Stramp lights.

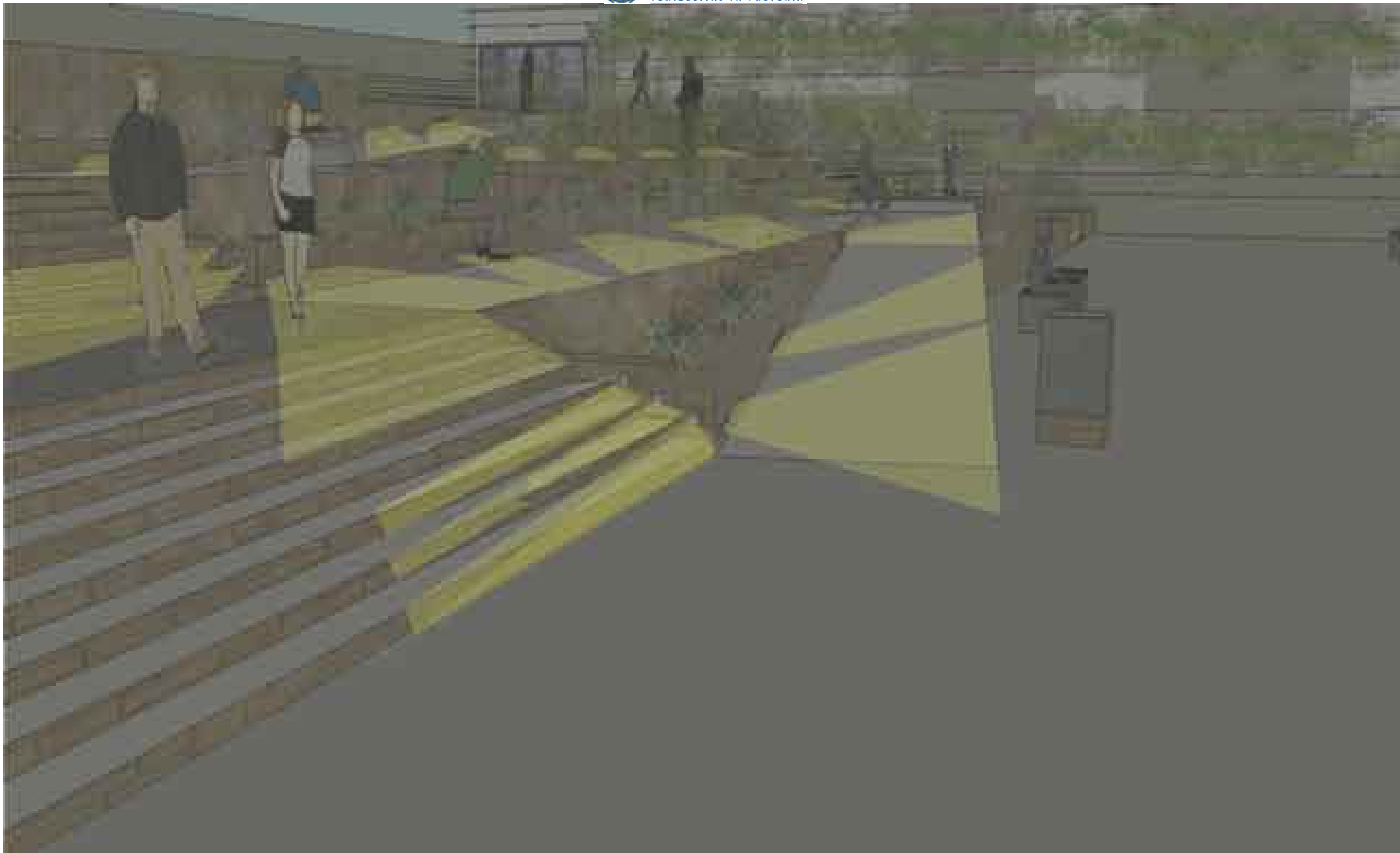

Fig. 6.112 Ramp access.



# JANUARY AFTERNOON

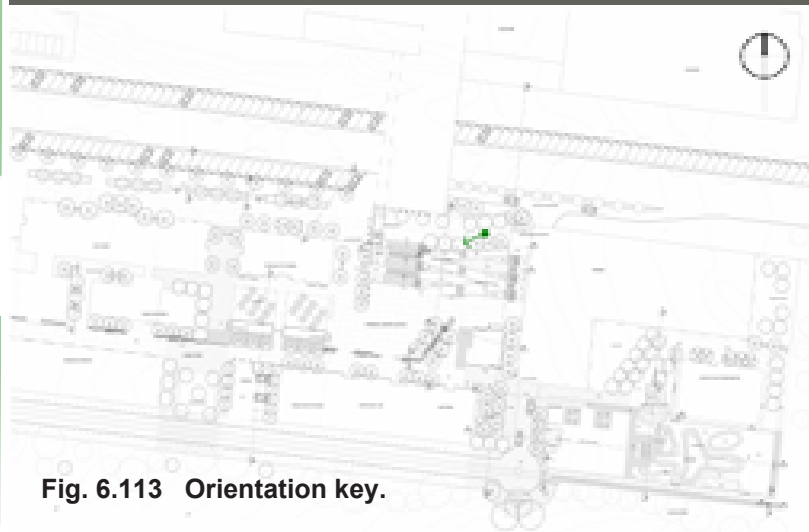

Fig. 6.113 Orientation key.



Fig. 6.114 Concrete surface.



Fig. 6.115 Glass panels.



Fig. 6.116 View from parkade access.

# JUNE AFTERNOON

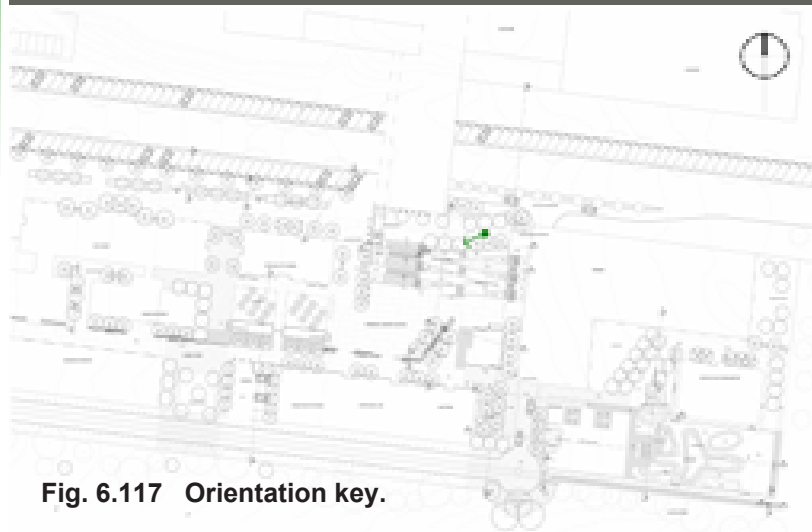

Fig. 6.117 Orientation key.



Fig. 6.118 Boulevard of trees.



Fig. 6.119 View from parkade access.



# TECHNICAL RESOLUTION

6

WETLAND

## Technical Resolution

The hydrological system on the site will consist of 3 parts:

- The wetland at the eastern corner of the site.
- The formal open water system running through the length of the site in an east west direction.
- The infiltration trenches in Lynnwood Road.

## Wetland system and existing channel

New approaches to wastewater treatment are a result in a change of perspective, a perspective based on a total ecosystem approach. Water is a valuable source of nutrients on which ecologically wetlands can subsist. The only treatment which occurs in natural systems is biological treatment.

### Design intend

The surface wetland is designed primarily to illustrate the cleaning of storm water runoff in an urban environment. A secondary objective include the creation of habitat and on a tertiary level the wetland system also poses to have educational value as interpretive signage will be erected to explain its role in the treatment of storm water.

There were two options available for intercepting and transporting water from a lower to a higher level. The first option was either to build a weir further upstream. The second option was to place a sump with a pump (which will be operated by solar panel batteries) in the existing base of the channel. The second option was considered as it drastically minimises the potential for flooding and does not decrease the area of the existing channel. Water pumping also offers one of the most efficient uses for solar electricity. The final aim is for the wetland system to function as a self sustaining ecosystem, supported by and supporting other ecosystems.

### Water quantities

Due to the urban nature of the site the water quantities are controlled through a solar pump which will pump a maximum volume of 110 m<sup>3</sup> water per day.

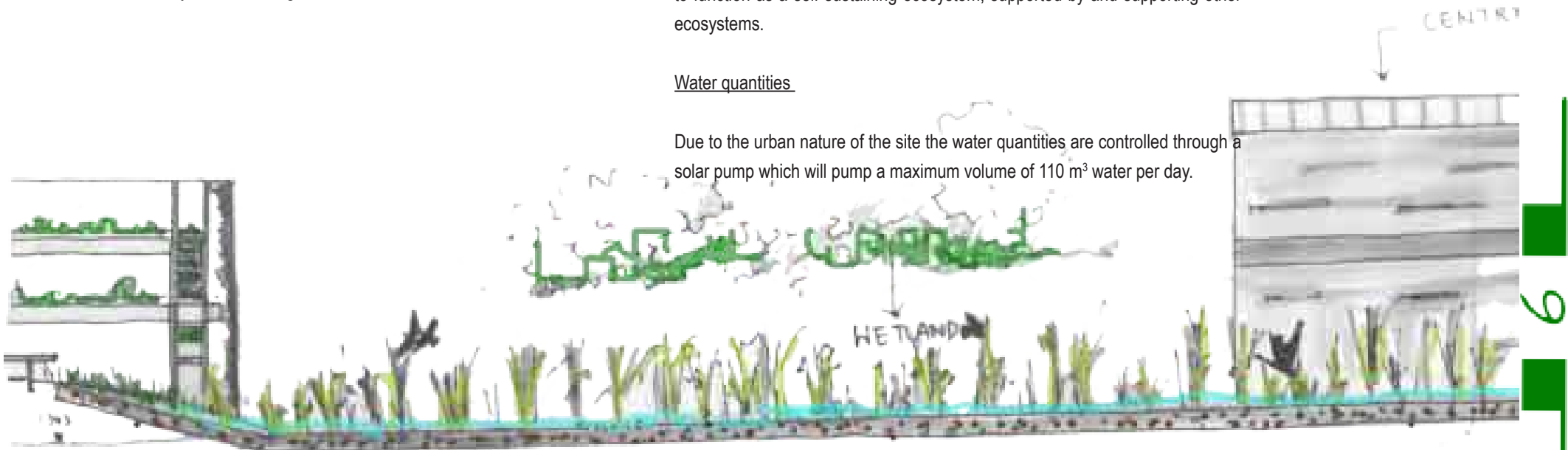

Fig. 6.120 Concept section.

Existing Channel

Total Area 3.58 m<sup>2</sup>

Catchment Area 160 ha (Refer to Chapter 3, figure 3.17)

Average speed of natural stream flow in channel 0.2m/s

Time of concentration 37 minutes

Q values

Base flow from natural stream 0.002 m<sup>3</sup> / s

Q2: 0.0053 m<sup>3</sup> / s

Q10: 0.008 m<sup>3</sup> / s

Q20: 0.097 m<sup>3</sup> / s

Q50: 0.014 m<sup>3</sup> / s

Q 100: 0.016 m<sup>3</sup> / s

Average flow from natural stream during summer months (0.002 m<sup>3</sup> / s)

2 litres/ second x 86400 s (24h) = 172 m<sup>3</sup> / day

172 m<sup>3</sup> / 2 (12 solar hours)

= 86.4 m<sup>3</sup> water / day (Average during summer months)

Average flow from natural stream during winter months (0.0004 m<sup>3</sup> / s)

0.4 litres/second x 86400 s (24h) = 34.56 m<sup>3</sup> / day

34.56 m<sup>3</sup> / 2 (12 solar hours)

= 17.28 m<sup>3</sup> water / day (Average during winter months)

For Q2 (0.0053 m<sup>3</sup> / s)

5.3 litres/ second x storm duration (Avg 30 min)

= 5.3 litres x 9540 seconds

= 50562 litres in total

**The conclusion can be made that the maximum volume of water the wetland will be able to treat will be 100 % from the natural stream flow and 50 % of rainfall for a storm which have a 50% chance of occurring in the given catchment area. The rest of the water will be channelled to Walkerspruit in a culvert underneath the service road.**

Amount of water effectively treated through wetland

L x W x D x 0.2

Length x Width x Depth x 0.2

65 x 17.3 x 0.5 = 552.5 m<sup>3</sup>

552.5 m<sup>3</sup> x 0.2 = 110.5 m<sup>3</sup> water effectively treated per day (Maximum during summer months)

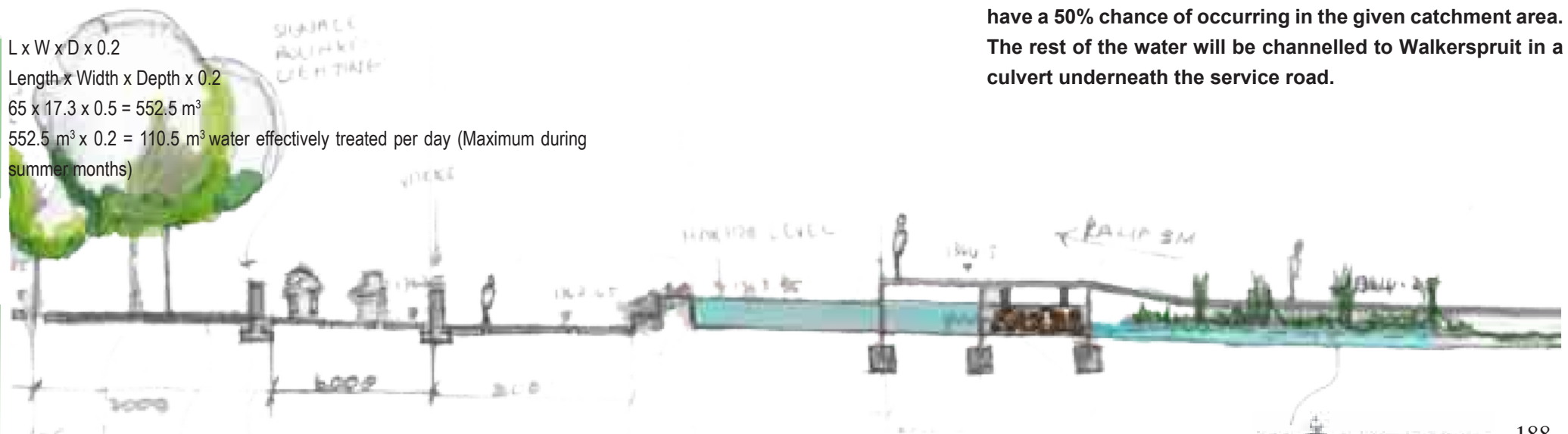
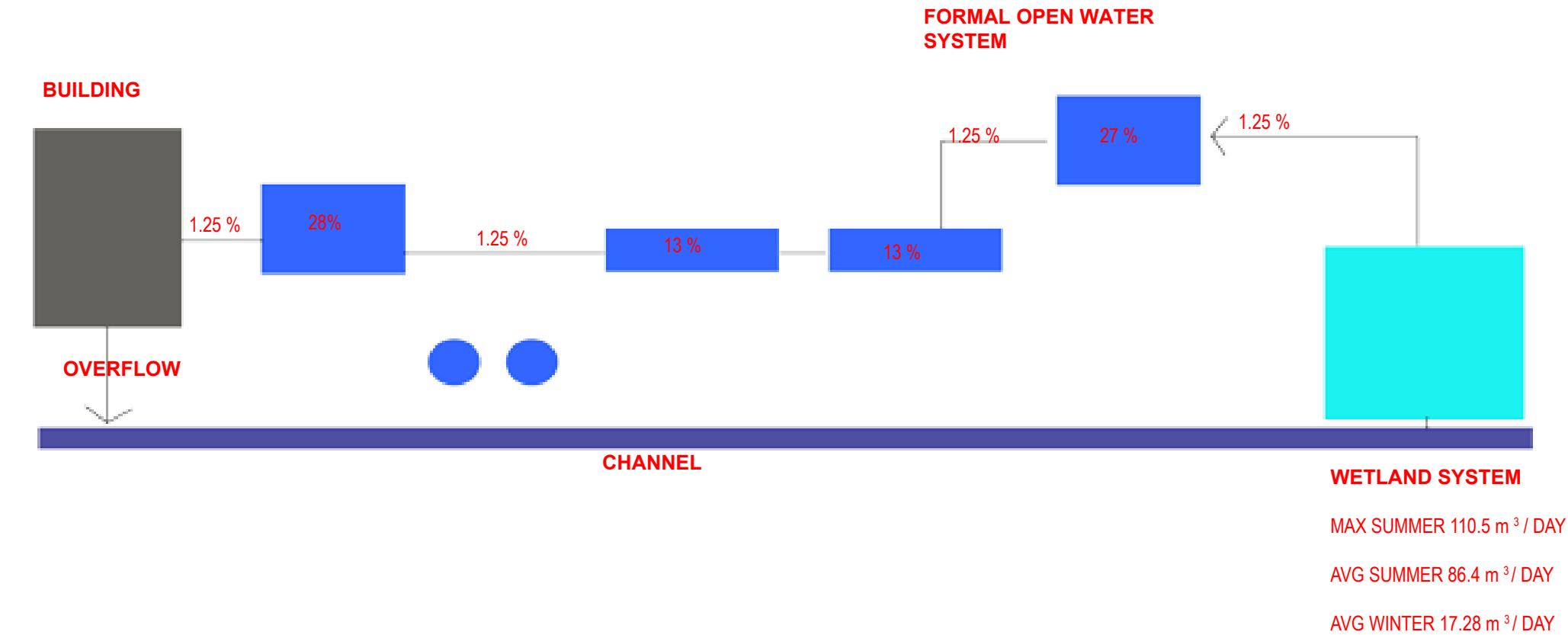

Fig. 6.121 Concept section.





Hydrology system

Fig. 6.122 Flow diagram.



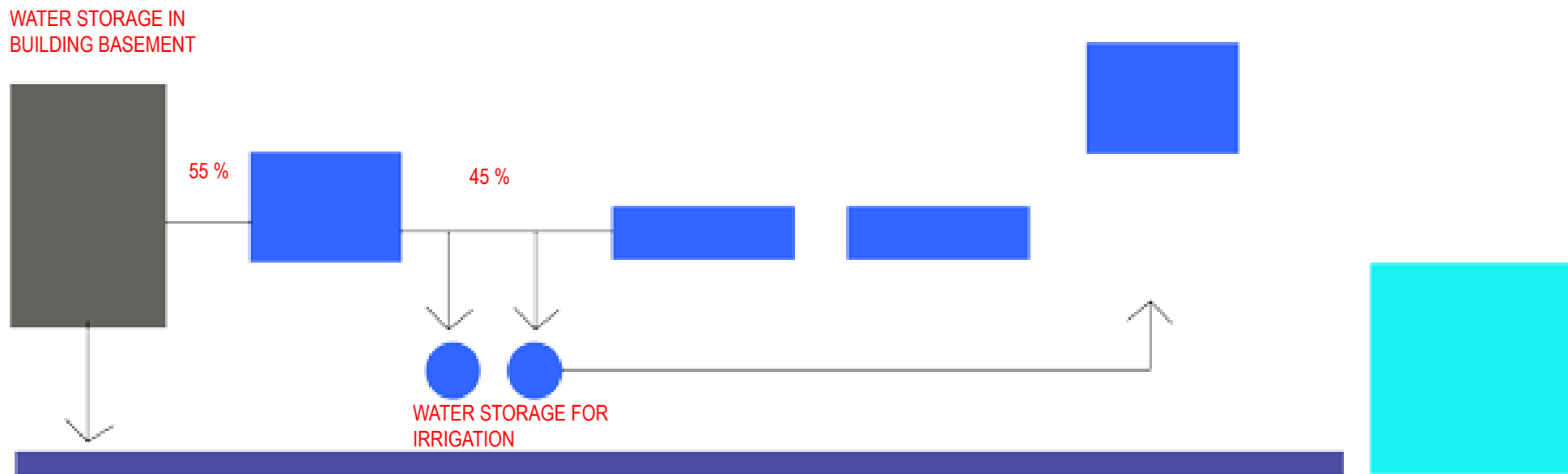

Fig. 6.123 Flow diagram.

### Water quality

The storm water entering the constructed wetland system will have a very low level of pathogens as this water mainly consists of runoff from the street and the nearby sport fields. As water moves through the system the biological oxygen demand will be reduced, particles will be filtered out and the roots of aquatic plants will help reduce nitrogen and phosphorous levels. (*Landscape Architecture, January 2004.*)

### Estimated pollutant removal capability

Nitrogen 50%

Heavy metals: 40 – 70%

([www.mckenziewaterquality.org](http://www.mckenziewaterquality.org))

### Plant species

Local indigenous planting ensures that plants are adapted to local environmental conditions.

When plants are established, their roots provide a habitat for beneficial bacteria to transform effluent. The substrate and roots act as reactors, which support microbes which prey on nutrients, and converting them into a form which plants can use. Plants also add air to the system through capillary action. The whole system forms a commensal relationship.

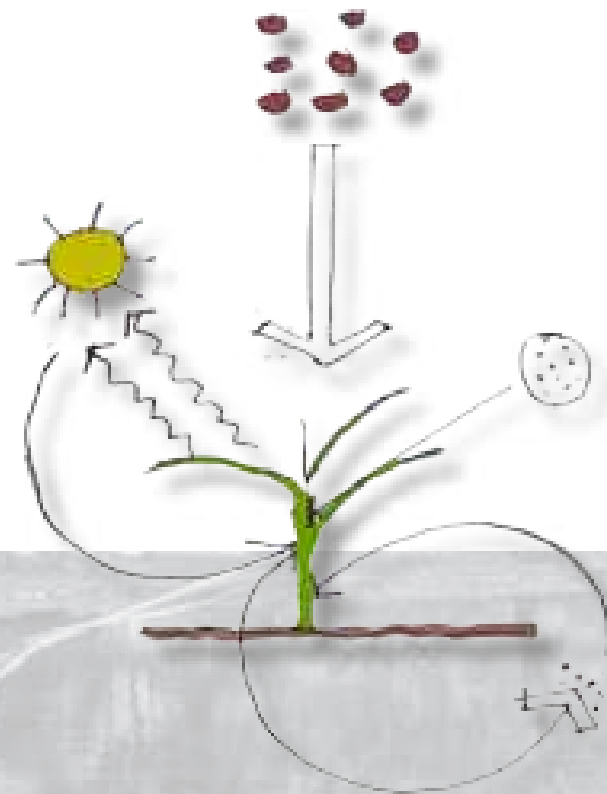

Fig. 6.124 Commensal relationship of wetland species.



## Materials

- Bentonite clay

The wetland's bottom lining will be constructed with Bentonite which is natural clay. When it is mixed with soil, compacted and placed in water it swells more than five times its volume. As a result of this it forms a sealant greatly reducing the water's ability to pass through. The clay is not harmful to fish and birds. ([www.clay.co.za](http://www.clay.co.za))

- Reno mattress and Gabions

The existing channel's bottom surface will be lined with Reno mattresses and its edges will be slightly widened to accommodate a gabion structure. The Reno mattresses will be filled with a silt substratum favourable to moisture loving plants. This is the most suitable material as the permeability of both these structures allows for natural vegetation growth and maximizes biological growth and biomass. This process favours the formation of micro organisms.

## Wetland establishment sequence

For the system to start operating sufficiently an initial amount of municipal water needs to be added into the wetland. This will only be necessary until the water has reached a certain level, after this the system will be able to support itself.

6 The area should be cleared and contoured to its final shape. The top layer is loosened and water is added to the required moisture level and Bentonite is spread over the top surface in 1m x 1m blocks and mixed into the soil.

The area is further hydrated by wetting the surface thoroughly; this allows the clay to swell between the open soil particles. ([www.clay.co.za](http://www.clay.co.za))



Fig. 6.125 Bentonite clay.

Fig. 6.126 Bentonite clay.

Nursery stock is transplanted or seeds from the Pretoria Boys High wetland can be harvested.

Subdivide no more than half of the wetland area into separate planting zones. The entire wetland should be covered within a period of 3 years.

A hydroseed mix should be used to establish permanent vegetative cover around the buffer area of the wetland. ([www.stormwatercenter.net](http://www.stormwatercenter.net))

Flow paths from the inlet to the outlet of the reed bed area are maximized. This is done by creating islands which enhances the micro topography and provides for ecological diversity as well as visual amenity.

To promote greater nitrogen removal a rock bed are used as a permeable membrane between the forebay and the reed bed area. ([www.stormwatercenter.net](http://www.stormwatercenter.net))

To reduce the levels of phosphorous wetlands require periodic harvesting, before the onset of summer. (*Landscape Architecture, January 2004.*)

#### Maintenance

Consideration has been given to the ease of maintenance. The intention of the grid is to act as a litter trap for coarse organic matter, allowing simple collection by maintenance staff. The pump in the channel will also be accessible through this grid in the base of the channel. (Refer to section E-E.) An access ramp on the eastern side of the wetland will allow for easy maintenance to pipes.

Reno mattress will be placed in the base of the channel; this will allow for excess soil and organic matter to be captured before entering the system. The pump can be switched off when it's necessary for critical maintenance to the wetland.

Fringe vegetation needs to be harvested and discarded periodically in order to expose of excess nutrients taken up by vegetation.

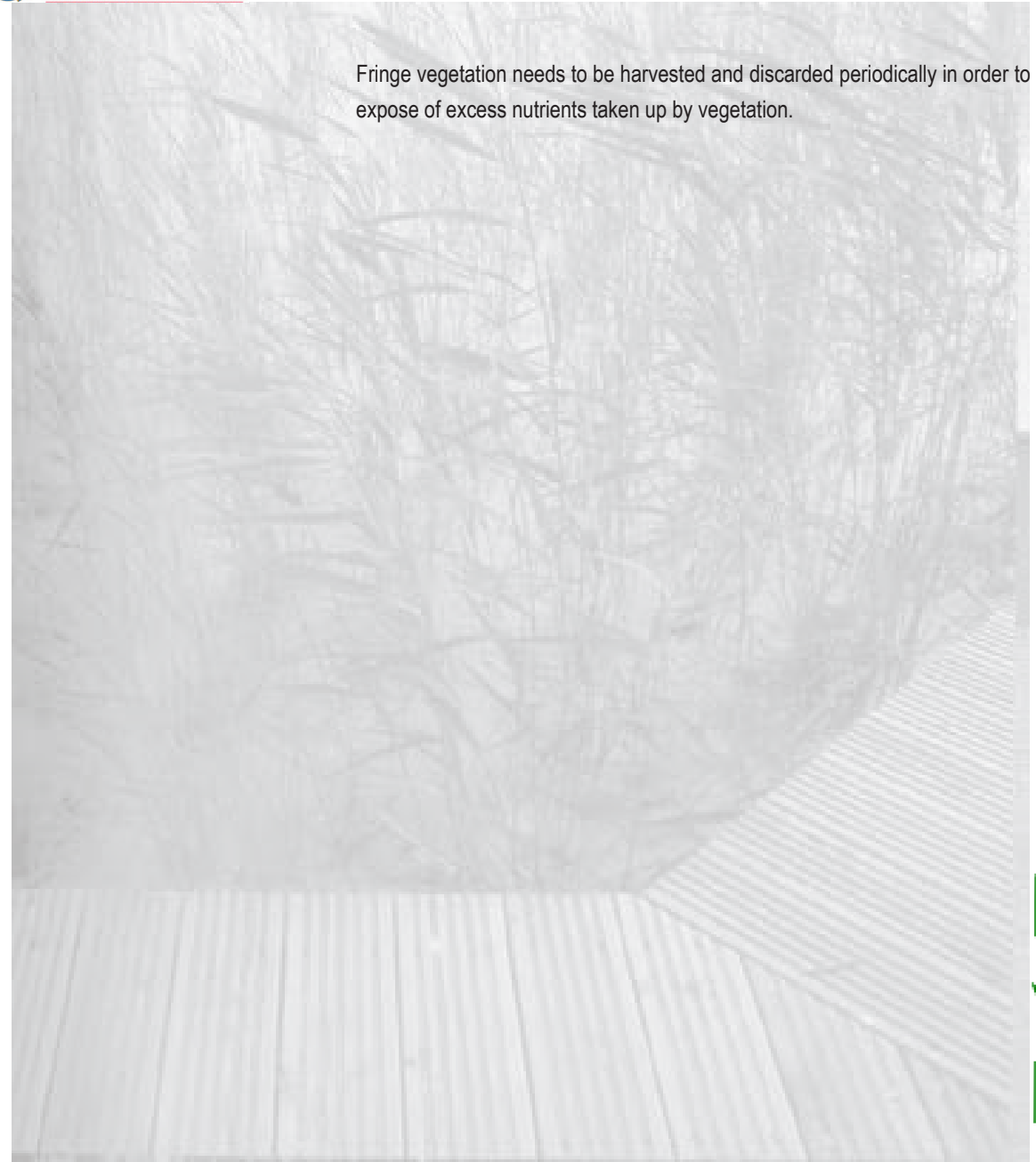

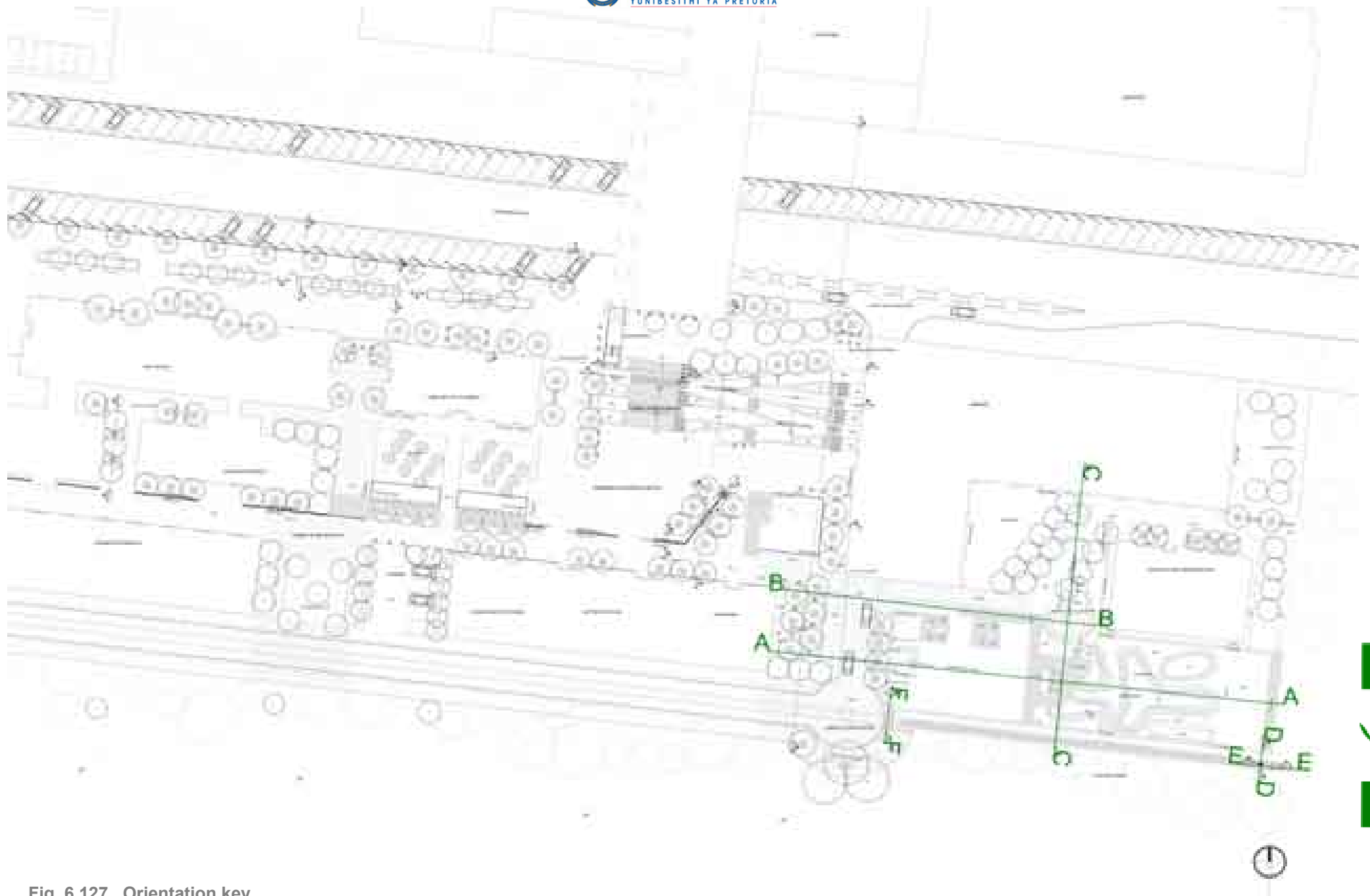

Fig. 6.127 Orientation key.

# FORMAL OPEN WATER SYSTEM

## Formal open water system

The controlled amount of water, pumped from the existing channel into the wetland system and is then gravity fed to an open body of water situated at the eastern side of the square. 45 % amount of the water will then be channelled to tanks and 55% amount of the water will be channelled to another body of open water situated on the western side of the site. Water leaving this open body of water will then flow into the basement of the School of Motion Picture. (Refer to figure 6.121)

### Small channel running through the site

- Flow speed

Total Area:  $0.15 \times 0.3 = 0.0045 \text{ m}^2$

Q value  $0.002 \text{ m}^3 / \text{s}$

$Q = V \times A$

$= 0.44 \text{ m/s}$

### Water quantities

- Maximum total volume of water in the channel  
 $274.3 \text{ m} \times 0.0045 \text{ m}^2 = 1.234 \text{ m}^3$
- Maximum total volume of water in the open formal bodies of water  
 $24 \text{ m}^3 + 22.94 \text{ m}^3 + 24.96 \text{ m}^3 = 71.9 \text{ m}^3$

## Total maximum volume of water in system 73.134 m<sup>3</sup>

During summer months the volume of water in the wetland is 15 – 33% higher than the volume of water in the formal open water system. This excess amount of water compensate for evaporation.

- Percentage of total volume of water which should be diverted to the tank system for landscape irrigation.

$0.03 \text{ m} \times 1270 \text{ m}^2 \text{ of soft planting} = 38.09 \text{ m}^3$

### Water quality

The water entering the system from the wetland will be “tertiary treated effluent” this means that the water will be clean enough for human contact or can be used for landscape irrigation, thus holding no danger for humans and wildlife.

### Materials

- Enviromat

The surface of the open water system will consist of enviromat topped with two layers of gravel. Enviromat is the most suitable material as aquatic plant roots are able to penetrate through the material. The plant roots serve as a food source, habitat and nesting material for various birds and animals. Thus it helps to increase biodiversity.

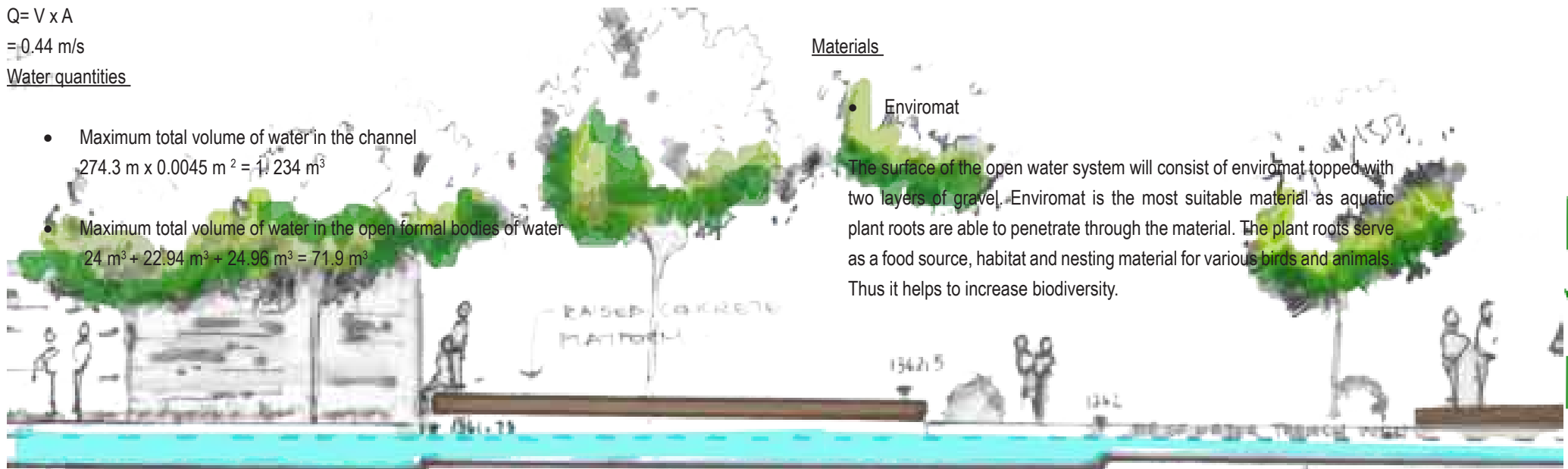

Fig. 6.128 Concept section.



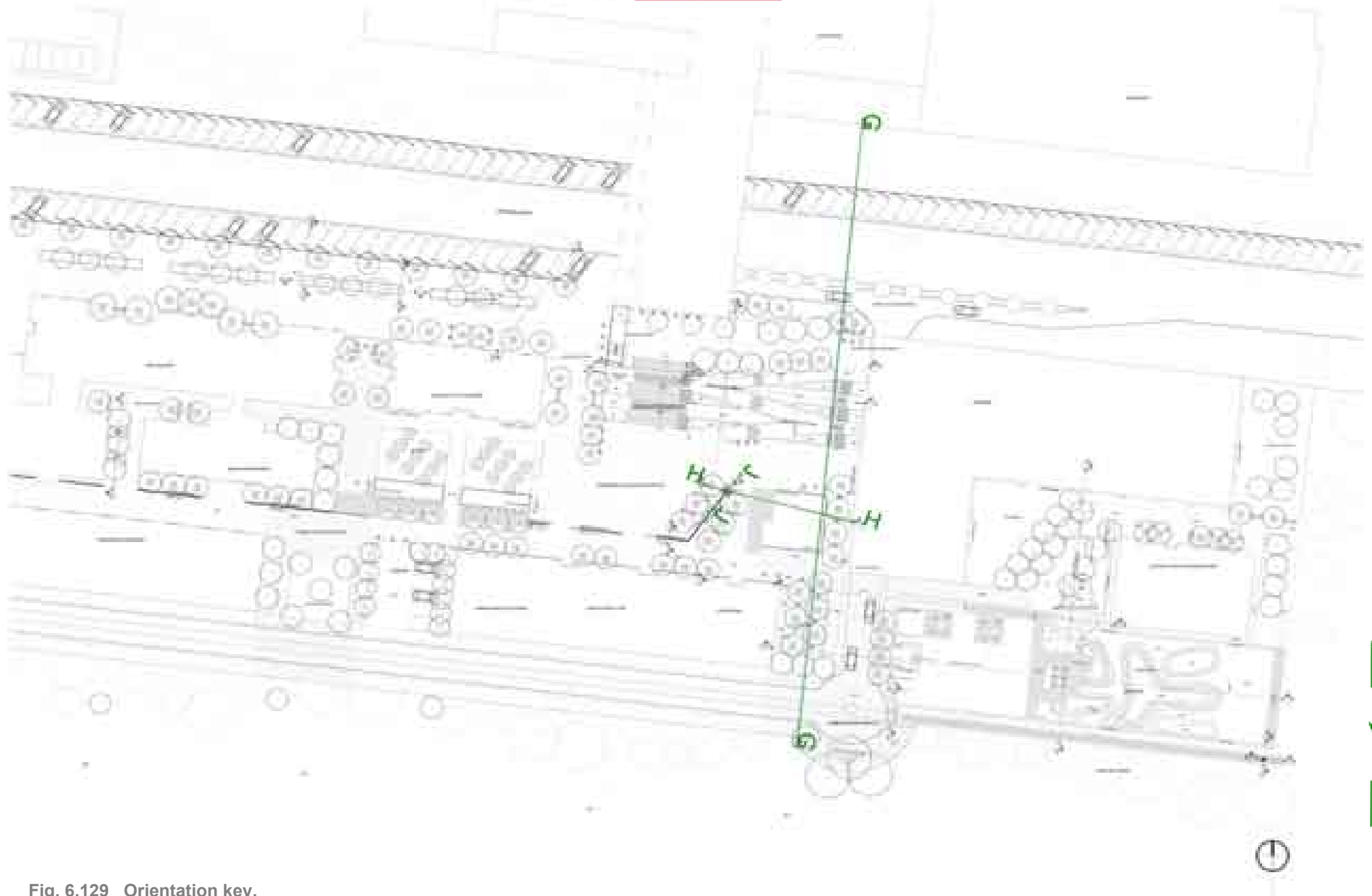

Fig. 6.129 Orientation key.

6

STRAMP

## Stramp

### Edges

- Materials

#### Concrete Retaining Blocks L13

The edges of the stramp are important as it is also viewed as a system, around and through which plants can grow. The vertical green wall cuts heat and glare, traps air pollutants, hold or slow rainwater and process CO<sup>2</sup> while providing food and shelter for wildlife. The green wall also ensures a comfortable micro climate which creates opportunity for informal seating spaces and lingering points.

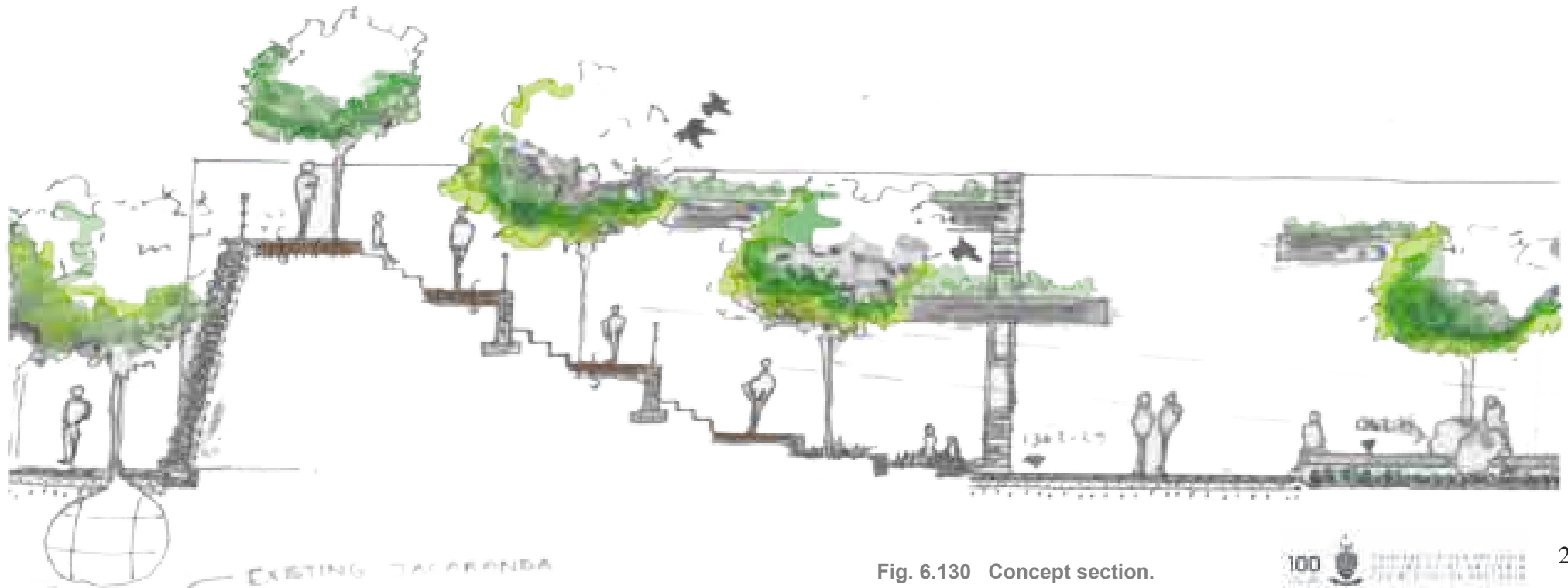

## Geotextile

Geotextile made of natural fibre is used as a transitional stabilization system. This material prevents erosion from flowing water, while trapping sediment, creating a protected and well aerated and hydrated growing zone for plants.

The material has a high water holding capacity, releasing moisture slowly back into the ground. It reduces the amount of root pathogens, while promoting strong root systems.

Fig. 6.130 Concept section.

- Vertical landscape

A vertical landscape is proposed on the façade of the parkade. A scaffolding framework enables a modular planting strategy. All plants will be watered by means of a simple drip irrigation system. The porosity of the scaffolding structure allows water and wind to assist the migration of flora and fauna between the levels.

#### Terraces

The plants in the terraced areas of the stramp will have an adequate irrigation system; drainage will be provided at the lowest points.

Fig. 6.131 Spatial view of stramp.

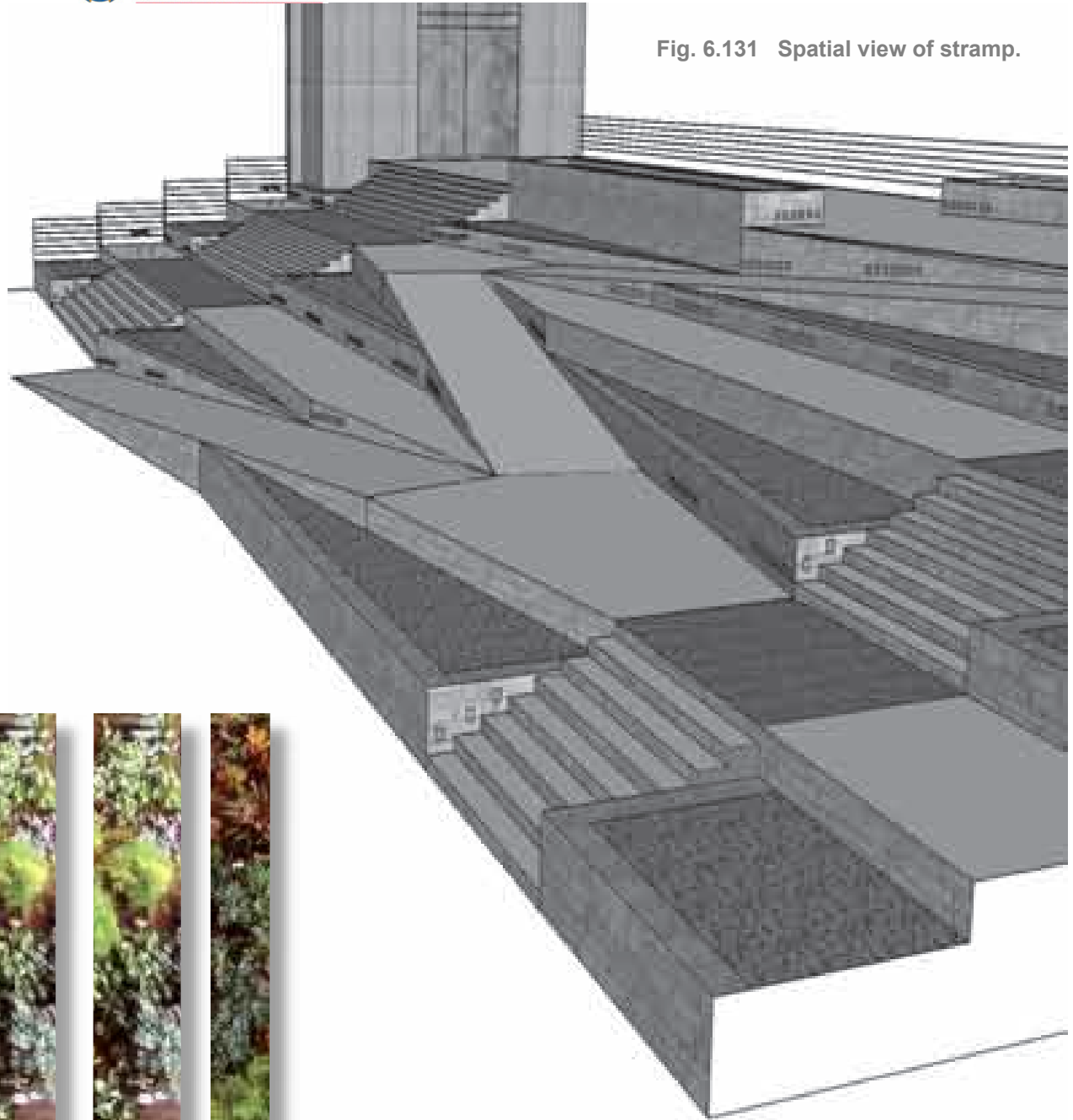

Fig. 6.132 Concept of vertical landscape. 100

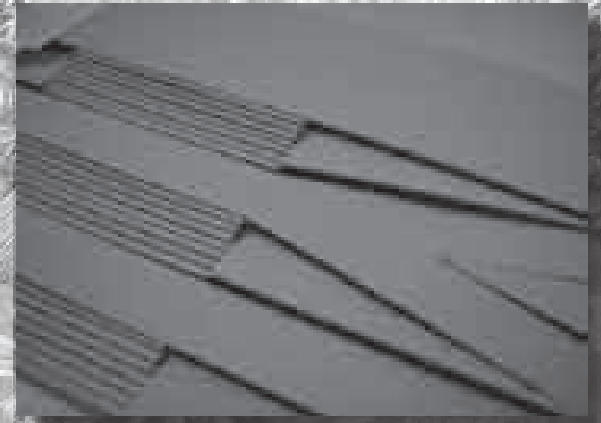
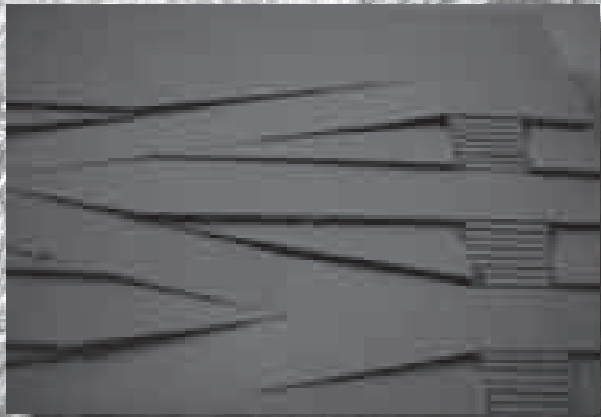

Fig. 6.133 – 6.135 Stramp model.

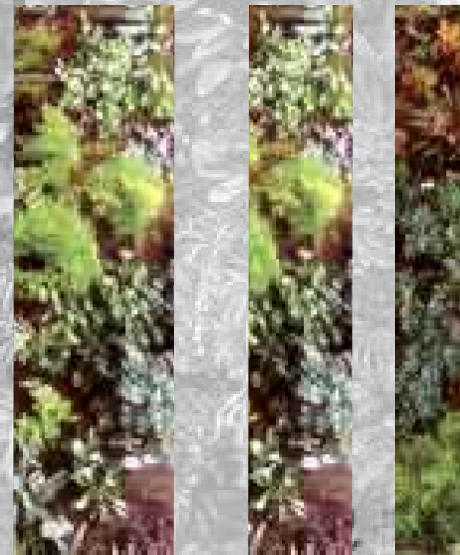

Fig. 6.136 Concept of vertical garden.

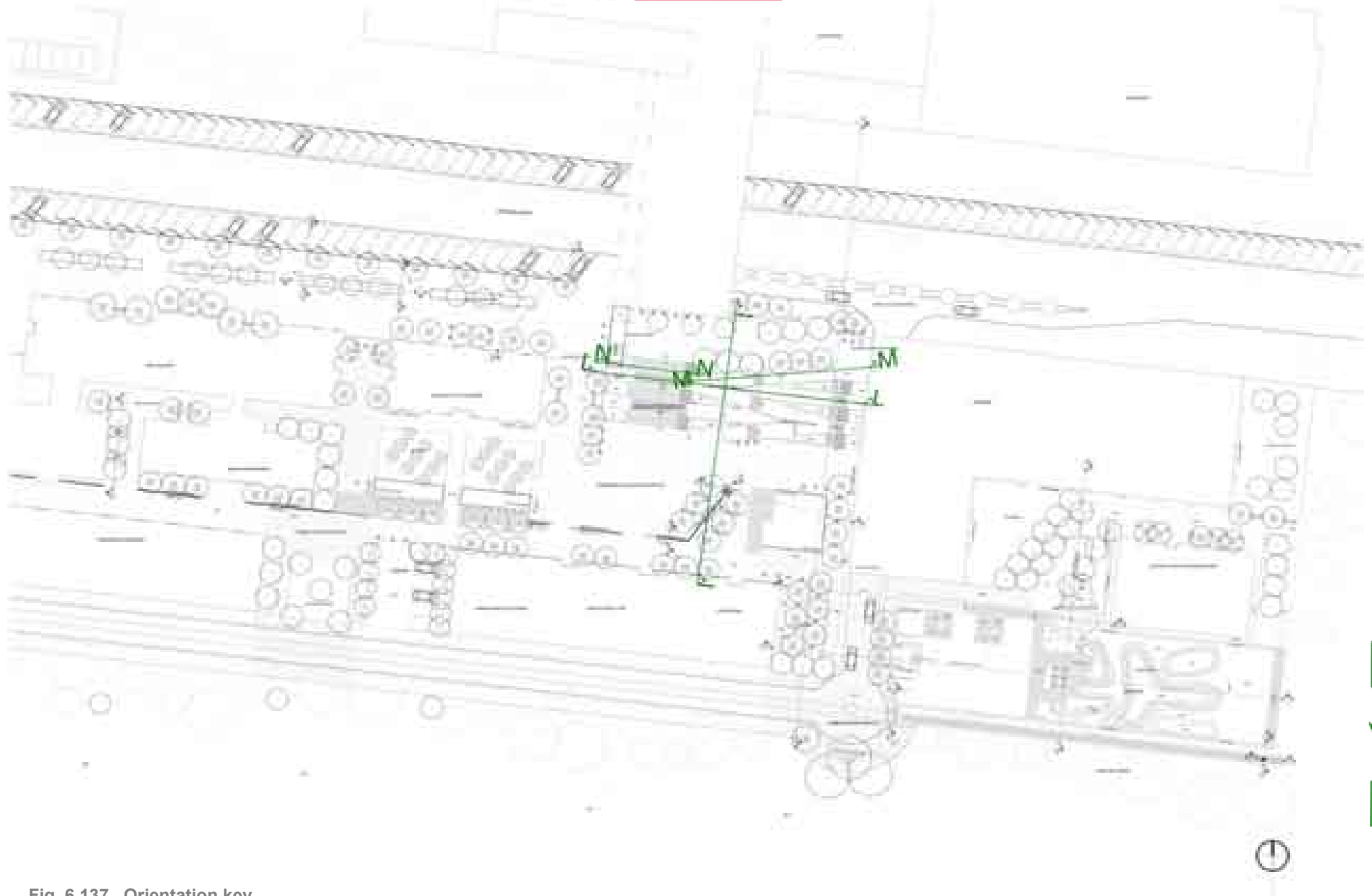

Fig. 6.137 Orientation key.

# INFILTRATION TRENCHES

## NETWORKED SIDEWALK STORM WATER SYSTEM PORTLAND BUREAU OF ENVIRONMENTAL SERVICES

Storm water runoff from the street are distributed through a sequence of infiltration trenches

The planters are designed to handle 60% of the street's runoff.

Planters are filled with an equal mix of sand, compost and loam.

The infiltration basins are cleaned from sediments periodically

The project compresses hydrological performance through a network and the system forms part of the streetscape.

*(Margolis, L & Robinson, A.2007.)*



**Fig. 6.138** Cut in the curb channel.



**Fig. 6.139** A wide street section accommodates stormwater treatment.

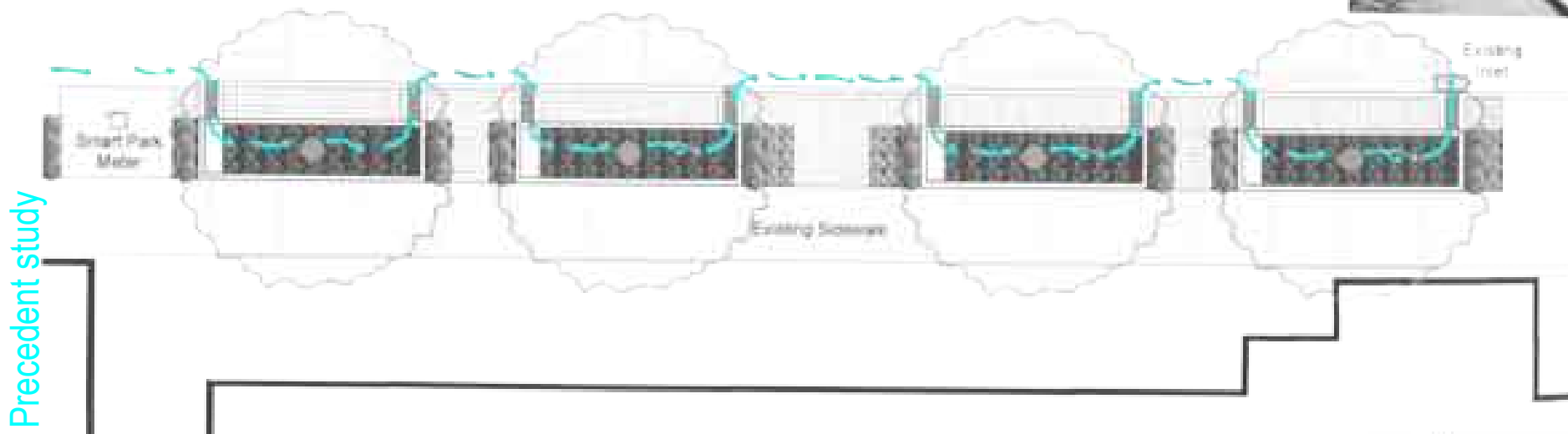

**Fig. 6.140** Storm water flow.



## Storm water infiltration trenches in Lynnwood Road

### Design intend

Storm water runoff from Lynnwood Road is distributed between a series of infiltration planters.

The infiltration trenches in Lynnwood Road will not significantly enhance the quality of water on a macro scale, but this will serve as a model for how storm water can be treated in urban areas.

The runoff from catchment area 2 ( refer to figure below) flows along the existing kerb until it reaches the first planter which collects runoff up to a 150 mm and infiltrates this at a rate of 10.16 cm/hr . If this height is reached, water then exits into the existing storm water inlet.

Runoff from catchment area 3 also flows along the existing curb until it reaches filtration trench 2 and once maximum capacity is reached it flows through the rest of the trenches until it reaches the existing storm water inlet at the corner of University and Lynnwood Road.

Time of concentration 22.6 min

- Q values

Q2 ( 25mm/h) = 0.01 m<sup>3</sup>/ s

Q10 ( 50mm/h) = 0.02 m<sup>3</sup>/ s

Q 20 ( 65mm/h) = 0.029 m<sup>3</sup>/ s

Q 50 ( 85mm/h) = 0.038 m<sup>3</sup>/ s

Q100 ( 100mm/h) = 0.045 m<sup>3</sup>/ s

Catchment Area 3

Total Area 0.32 ha / 2 = 0.16 ha

Roughness coefficient 0.02

Flow path 236 m

Average slope: 1:44

Time of concentration 19.8 min

- Q values

Q2 ( 25mm/h) = 0.011 m<sup>3</sup>/ s

Q10 ( 50mm/h) = 0.022 m<sup>3</sup>/ s

Q 20 ( 65mm/h) = 0.028 m<sup>3</sup>/ s

Q 50 ( 85mm/h) = 0.037 m<sup>3</sup>/ s

Q100 ( 100mm/h) = 0.044 m<sup>3</sup>/ s

### Water quantities

- Catchment Area 2

Total Area: 0.326 ha / 2 = 0.163 ha

Roughness coefficient: 0.02

Flow path: 315m

Average slope: 1:44

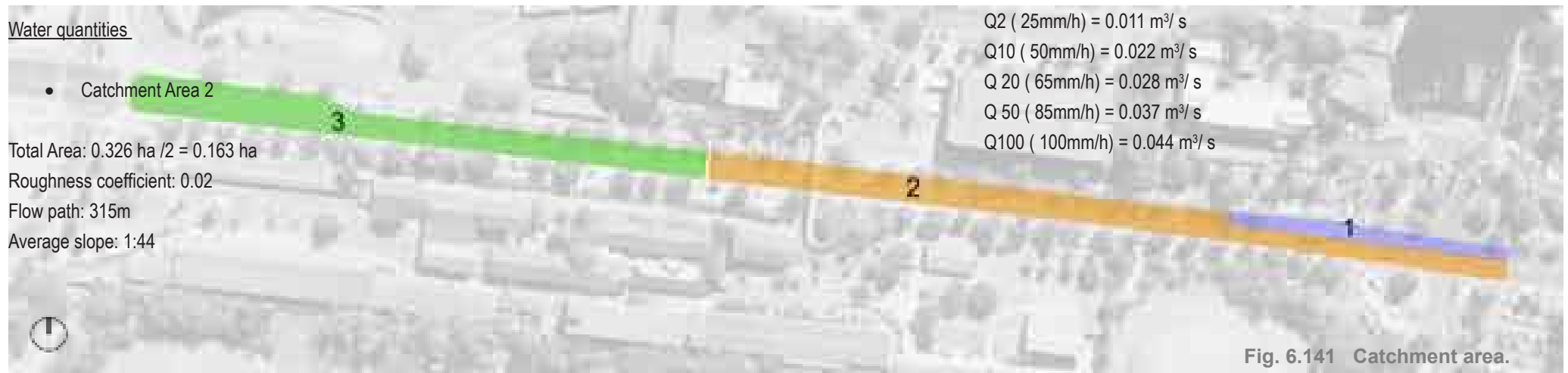

Fig. 6.141 Catchment area.

- Percentage of water treated

Maximum allowable water volume per trench:  $0.15 \times 18.26 \times 1.5 = 4.1 \text{ m}^3$

For catchment area 2

Infiltration trench 1 and 2

Total volume  $8.2 \text{ m}^3$

For Q2:

$10 \text{ litres / s} \times 1356 \text{ s}$

$= 13560 \text{ litres}$

$= 13.56 \text{ m}^3 \times 2$

$= 27.12 \text{ m}^3$

Thus the conclusion can be made that Infiltration trench 1 and 2 will be able to handle 66 % of rainfall for a storm which have a 50% chance of occurring.

For catchment area 3

Infiltration trench 3– 11

Total volume  $36.9 \text{ m}^3$

For Q2:

$11 \text{ litres/ s} \times 1188 \text{ s}$

$= 13068 \text{ litres}$

For Q10:

$22 \text{ litres /s} \times 1188\text{s}$

$= 26136 \text{ litres}$

For Q 20:

$28 \text{ litres/s} \times 1188\text{s}$

$= 33264 \text{ litres}$

For Q 50;

$37 \text{ litres/s} \times 1188 \text{ s}$

$= 43956 \text{ litres}$

Infiltration trench 3-11 will be able to handle an estimated 80 % of the rainfall for a storm which have a 2 % of occurring.

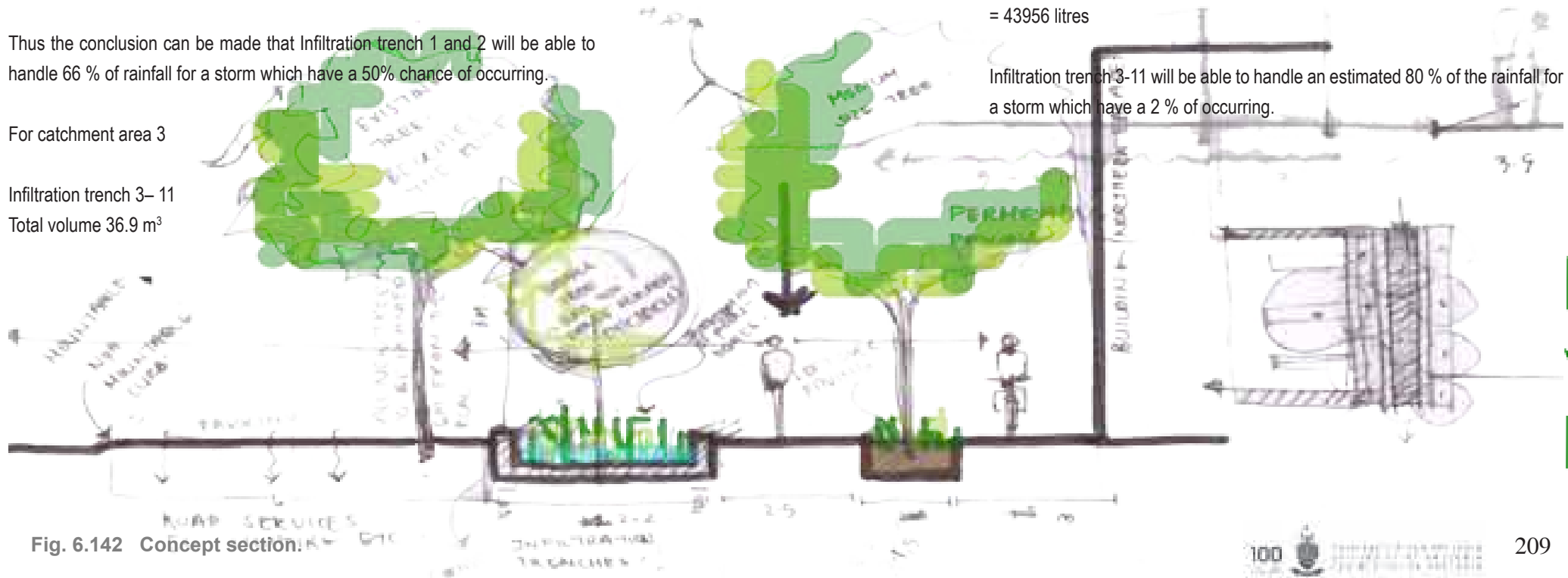

Fig. 6.142 Concept section: 1:10

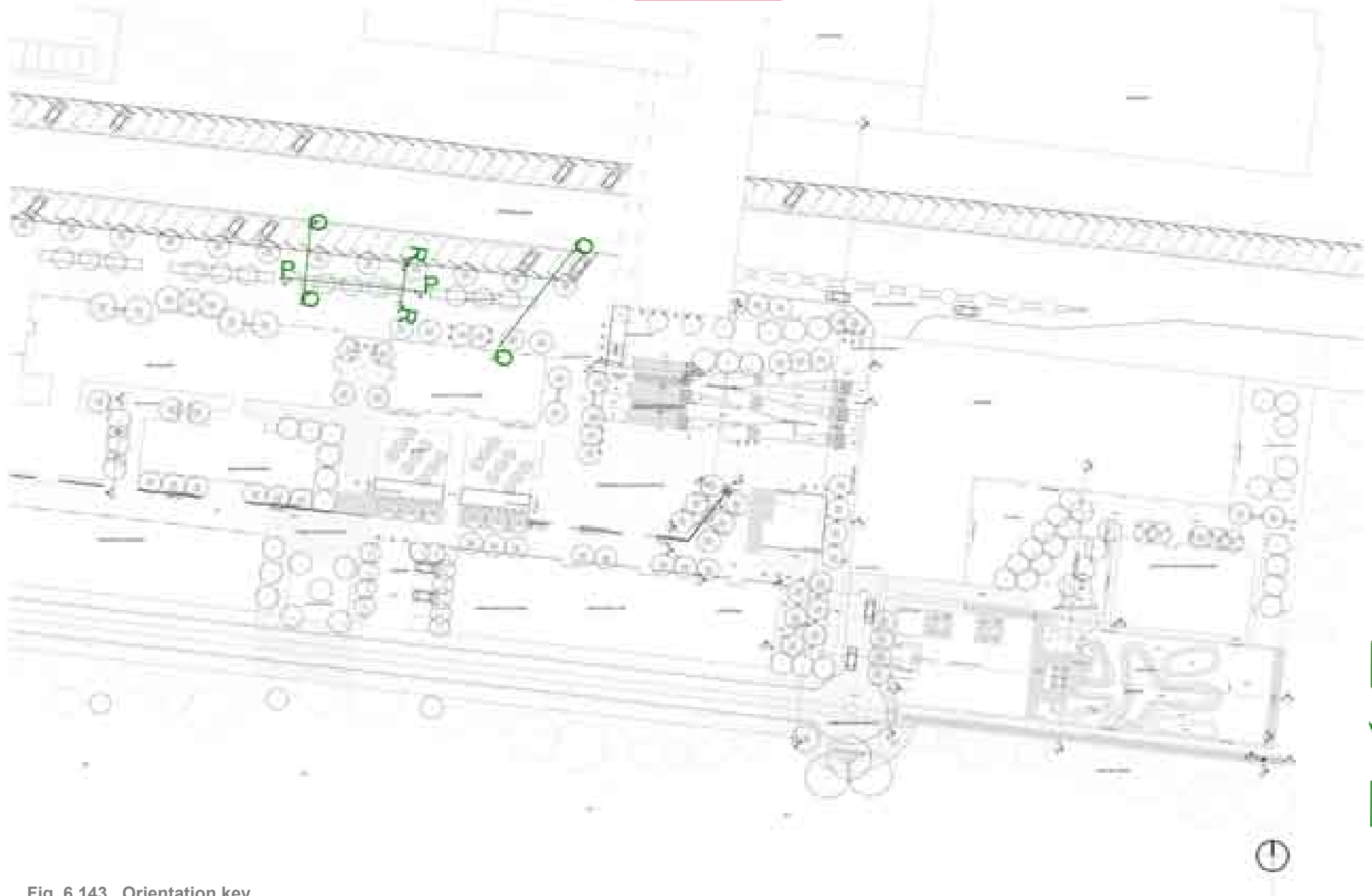

Fig. 6.143 Orientation key.



# CHAPTER 7

## CONCLUSION

## CHAPTER 7 CONCLUSION

Designing for living systems on a local, as well as on a district scale, is an essential component which will contribute to a sustainable future in the 21<sup>st</sup> Century. By combining urban and natural processes at local level, a new integrated design language emerges. This integrated design is of great value to the evolving form of the city. Borrowing from the bio physical environment involves practicing adaptive management, a process of learning by doing.

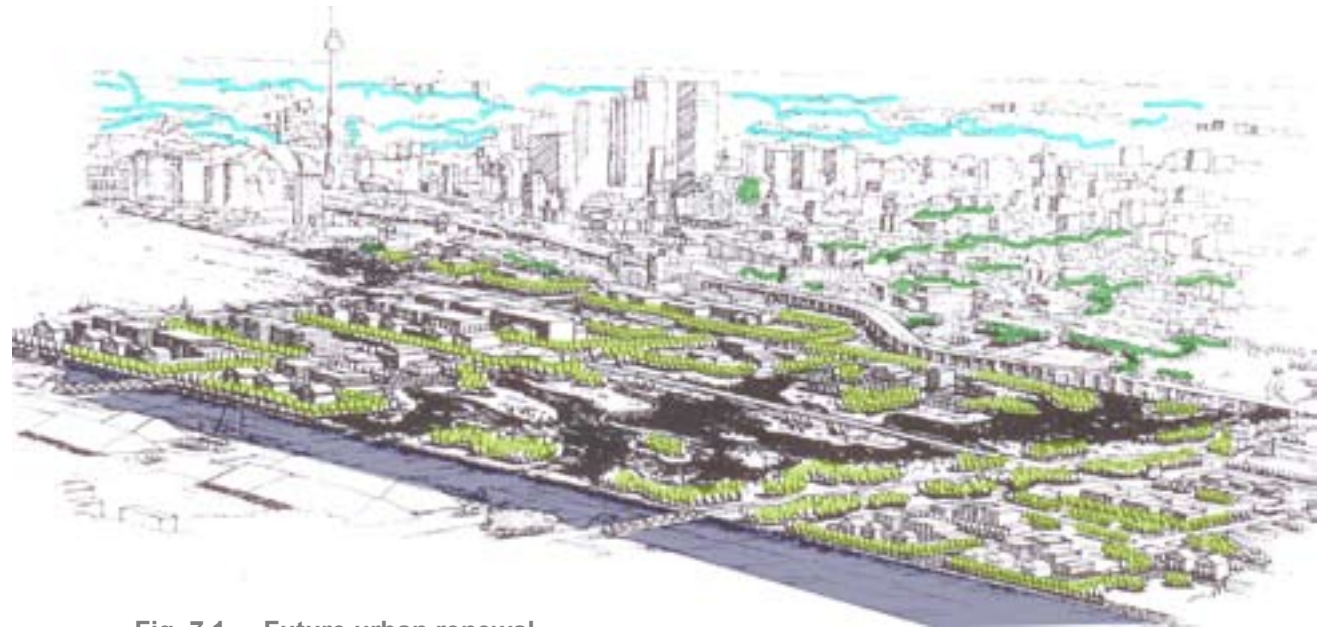

Fig. 7.1 Future urban renewal.



# CHAPTER 8

## REFERENCES

## Books

ADDIS, B.2007. *Building with reclaimed components and materials, a design handbook for re use and recycling*. London: Earthscan.

BAUMEISTER, N & PITZ, H.2007.*New Landscape Architecture*, Berlin: Verlaghaus Braun.

BERGER, A.2006. *Drosscape, Wasting Land in Urban America*, New York: Princeton Architectural Press.

BYBELGENOOTSKAP VAN SUID - AFRIKA.1991. *Die Bybel, Nuwe Vertaling*, Kaapstad: Nasionale Boekdrukkery.

CARSON, R.1962. *The Silent Spring*, Boston: Mifflin Company.

CERVER, F.A.1996? *Environmental Restoration – Landscape*, New York: Arco Editorial.

COMMONER, B.1990. *Making peace with the planet*, New York: Dantheon Books.

CORNER, J. 1999. *Recovering Landscapes; Essays in Contemporary Landscape Architecture*, New York: Princeton Architectural Press.

## Articles from Recovering Landscapes:

WALDHEIM, C. Aerial Representation and the Recovery of Landscape  
MAROT, S. The Reclaiming of Sites

CONAN, M. 2000. *Environmentalism in Landscape Architecture*, Washington D.C: Dumbarton Oaks.

## Articles from Environmentalism in Landscape Architecture:

MEYER.E.K. The Post Earth Day Conundrum: Translating Environmental Values into Landscape Design.

EHRlich, P.R.1987. *The science of ecology*, New York: Macmillan Publishing Company.

HARRIS, C. & DINES, N. 1997. *Time – Saver Standards for Landscape Architecture*. New York: McGraw – Hill.

HOUGH, M.2004. *Cities and Natural Processes: A Basis for Sustainability*. London: Taylor and Francis Ltd.

KWOK, G et al.2007. *The Green Studio Handbook, Environmental Strategies for Schematic Design*, San Diego: Architectural Press.

LEEDY, P.D. & ORMROD, J.E. 2005. *Practical Research, Planning and Design* 8<sup>th</sup> Edition. New Jersey; Pearson Education.

LOVELOCK, J.1988. *The ages of Gaia*, Oxford: Oxford University Press.

LYLE, J.T. 1994. *Regenerative design for Sustainable Development*. United States of America: John Wiley and Sons, Inc.

# REFERENCES

MARGOLIS, L. & ROBINSON, A.2007.*Living Systems: Innovative materials and technologies*, Boston: Birkhauser Verlag AG.

ODUM, E.1993. *Ecology and our Endangered life support systems*, Philadelphia: Sinauer Associates.

Organisation for Economic Co Operation and Development .1974. *Streets for People*, Paris: OECD Publications.

PEARSALL, J. 2002. *The Concise Oxford English Dictionary*, Oxford: Oxford University Press.

PRETORIA BOYS HIGH.2000. *The Story of a South African School 1901 – 2001*. Pretoria: ABC Pers.

Royal Commission on the Future of the Waterfront.1992.Regeneration: *Toronto's waterfront and sustainable city*: final report. Toronto, Canada: Queens Printer of Ontario.

SWAFFIELD, S.2002. *Theory in Landscape Architecture, a Reader*, Philadelphia: University of Pennsylvania Press.

Articles from Theory in Landscape Architecture:

SPIRN, A.W. 1984. The Granite Garden

RUFF, A.1982. An ecological approach.

LYLE, J.T.1991. Can floating seeds make deep forms?

NASSAUER, J. 1995. Messy Ecosystems, Orderly Frames

LYLE, J.T.1985. Designing for Human Ecosystems

THOMAS, V. & GRANT, R. 2002. *Sappi Tree Spotting, Highveld and the Drakensberg*. Johannesburg: Jacana.

THOMPSON, F.G. & STEINER, F.R. 1997.*Ecological Design and Planning*, New York:

John Wiley and Sons, Inc.

Articles from Ecological design and Planning

WOODWARD, J. Signature- Based Landscape Design

MEYER, E.K. The expanded field of Landscape Architecture

THOMPSON, J.W. & SORVIG, K.2000. *Sustainable Landscape Construction, a Guide to Green Buildings Outdoors*, Washington, D.C: Island Press.

TRANCKI, R.1986. *Finding Lost Space*, New York: Van Nostrand Reinhold Company Inc.

Universiteit van Pretoria.1996.1982 – 1992. *AD Destinatum III, n Geskiedenis van die Universiteit van Pretoria*, Pretoria. Universiteit van Pretoria.

VAN OUDTSHOORN, F.2006. *Guide to Grasses of Southern Africa*. Pretoria: Briza Publications.

VAN WYK, P. & VAN WYK, B. 1997. *Field Guide to Trees of Southern Africa*. Cape Town: Struik.

# REFERENCES



WALDHEIM, C.2003. *The Landscape Urbanism Reader*, New York: Princeton Architectural Press.

CARRATHERS, V.2000. *The Magaliesberg*, Pretoria: Protea Book House.

### Electronic articles

City of Tshwane Metropolitan Municipality. 2006. *Tshwane Regional Spatial development Framework Central Western Region*.

<http://www.tshwane.gov.za/documents/cityplanning/rsdf/CentralWesternRegion.pdf> (Accessed: 19 March 2008)

South African weather service. <http://www.weathersa.co.za>. (Accessed 29 March 2008)

Duisberg Nord Landscape Park, *Sustainable Architecture*, case studies. <http://arch.hku.hk>. (Accessed 8 March 2008)

LA BELLE, J.M.2001. *Emscher Park, Germany – Expanding the definition of a park*. <http://georgewright.org>. (Accessed 08 March 2008)

BEARDSLEY, J. 2000. A word for Landscape Architecture, *Harvard Design Magazine*, Number 12. <http://www.gsd.harvard.edu> (Accessed 08 March 2008)

TOPFER, K. *Maurice Rose Airfield, Frankfurt am Main International Urban Landscape award* 2006. Topos nr 56. <http://www.eurohypo.com/media/pdf>. (Accessed 29 March 2008)

Xochimilco Ecological Park. <http://redscolor.icle.edu> (Accessed 3 April 2008)

American Society of Professional Awards, *General Design of Honor*. <http://www.asla.org>. (Accessed 8 April 2008)

Organic Solutions. <http://www.globalworming.co.za>. (Accessed 7 May 2008)

CLAYTOR, R.A. & SCHEULER, T, R. *Design of Storm Water Filtering Systems*, Chesapeake Research Consortium. 1996. <http://www.mckenziewaterquality.org> (Accessed 22 June 2008)

Performance Criteria: *Wetlands*. <http://www.stormwatercenter.net> (Accessed 30 June 2008)

*Bentonite*. <http://www.clay.co.za> (Accessed 3 August 2008)

*Pervious Concrete, when it rains it drains*. <http://www.perviouspavement.org>. (Accessed 3 August 2008)

*Campus Design Principles*. <http://www.pp.okstate.edu>. (Accessed 14 April 2008)

EARTH 911 STAFF. *Composting with worms*. <http://www.eart911.org>. (Accessed 7 May 2008)

Full Cycle, *Vermiculture*. <http://www.fullcycle.co.za>. (Accessed 7 May 2008)



# REFERENCES

44 Stanley Avenue. <http://www.44stanley.co.za>. (Accessed 8 March 2008)

<http://www.joburgnews.co.za>. (Accessed 8 March 2008)

*An old American army base reclaimed.* 2 July 2007. <http://green-blogspot> (Accessed 3 April 2008)

## Journals

PADUA, M.G. 2006. Touching the Good Earth, An innovative campus design reconnects students to China's agricultural landscapes. *Landscape Architecture*. December 2006, volume 96, no 12, p 100 – 107.

BREDENKAMP, G.J. 2003. *The South African Journal of Botany*, March 2003, volume 69, pp 7 – 26.

REBELE, F. 1994. Urban ecology and Special Features of Urban Ecosystems, *Global Ecology and Biogeography Letters*, November 1994, volume 4, no. 6, pp 173 – 187.

STEINFELD, C. & DEL PORTO, D. 2004. Growing Away Wastewater, *Landscape Architecture*, January 2004, volume 94, no. 1, pp 44-53.

## Other information

Storm water information:

[http://mntnetmis002/servlet/com.esri.esrimap.Esrimap?ServiceName=Tswane\\_Overview](http://mntnetmis002/servlet/com.esri.esrimap.Esrimap?ServiceName=Tswane_Overview) (12 February 2008).

Sewage information:

[http://mntnetmis002/servlet/com.esri.esrimap.Esrimap?ServiceName=Tswane\\_Overview](http://mntnetmis002/servlet/com.esri.esrimap.Esrimap?ServiceName=Tswane_Overview) (12 February 2008).

City of Tswane: City Planning and Regional Services Department.2008. *Zoning Certificate for the remainder of portion 332 and portion 468 of the farm Elandspoort 357- JR*, Pretoria Town planning scheme, 1974.

ZANZOT, J.2007 Class notes: *The RE Generation & Living Systems Design*, University of Pretoria.

CSIR.1980.*Fuel Research Institute of South Africa Brochure 1930-1980*.Pretoria: CSIR Graphic Arts Division.

AAL 310.2005.*Class notes*.

JORDAAN, G.2008. *Proposed framework for the University of Pretoria*.

HINDES, C.2003. *Class lecture OML 110*, University of Pretoria.

CLAASSEN, C. 2008. *Dis buslis nodig vir 2010*, Beeld, 1 Maart.

Census statistics 2003

POTGIETER, D.2008. *Personal interview*.

# REFERENCES

# CHAPTER 9

## APPENDICES





APPENDIX 1 : U.P FRAMEWORK

## VISION STATEMENT

“TRANSFORMING THE UNIVERSITY OF PRETORIA FROM AN ISOLATED FRAGMENTED KNOWLEDGE PRODUCTION INSTITUTION, TO A **UNIVERSITY CITY, A CITY OF INNOVATION.**”

Transforming the University and the Hatfield precinct in to a **UNIVERSITY CITY**, an integrated networked city of innovation and social cohesion, where public sector interfaces with the private sector, interfaces with the academic sector. Removing physical, social and virtual boundaries that are constraining both the University and Hatfield precincts growth, creating social amalgam that celebrates and empowers the uniqueness, vitality, potential and culture of South Africa’s premiere Academic community.

The transformation is a two phased proposal with a single vision as driving force; it consists of the transformation of the University into a “University City” and concurrently the transformation of Hatfield into a diverse, vibrant and regenerative social hub that enables the conception of a University City.

### University Village

The University of the Future is the University of Pretoria, is a city of knowledge. The UP as a village is the first step in achieving the vision of the university as a city. A village that is the “brain” of the “ University City” a village where the urban fabric is design at a human scale, where the buildings become nodes of human and social interaction, and exterior spaces act as outdoor rooms for academic discourse and social play; A village that has its own tangible and definable character , identity and vitality , a village that has clarity of circulation that is dominated by pedestrians; A village that is designed for the night time , which has a vibrant and cultural night life. The

university village will function as a community, working as an inter – related whole a symbolic relationship of allied units. The transformation of the university into a village will prepare it to continue functioning as a holistic entity when integrated with the “University City” precinct.

### Social Hub

Hatfield precinct is to be developed to create a destination place. A place of continual social , cultural and civic regeneration; a place that defines its self as the vibrant , multifunctional “ body” of the “ University City” , Hatfield is to be the gateway of the “ University City” precinct . Hatfield’s continual transformation will be driven by the creation of interdependent nodes including, transport, mixed use, culture, commerce and political , allowing a dynamic interface for social expression. Hatfield must become a place for the people, for businessman, academics, students, professionals, politicians, workers; Hatfield must be a place for all.

### The University City

To achieve the University of Pretoria’s strategic objective of becoming a world class research institute, the Hatfield “social hub” and the “university village” need to merge from two vibrant successful independent isolated entities to a coherent spatially integrated community, without boundaries and borders. The future is now and that brings with it the world of virtual places, virtual lectures, virtual libraries and virtual paths, thus there is an intense need to allow the community to enter upon campus grounds to fully utilise all facilities that will become obsolete in the virtual age. The unification of these two distinct identities must not allow the dissolution of either’s unique identity but rather reinforce each other’s key strengths and opportunities to allow a true city of knowledge to be born, a “UNIVERSITY CITY”

KEY INDICATORS

- VITALITY
- ACCESSIBILITY
- DIVERSITY
- EQUITY
- CONTROL



## APPENDIX 2 : BRT ROUTE

## Fase 1 van die Bus Rapid Transport se roete

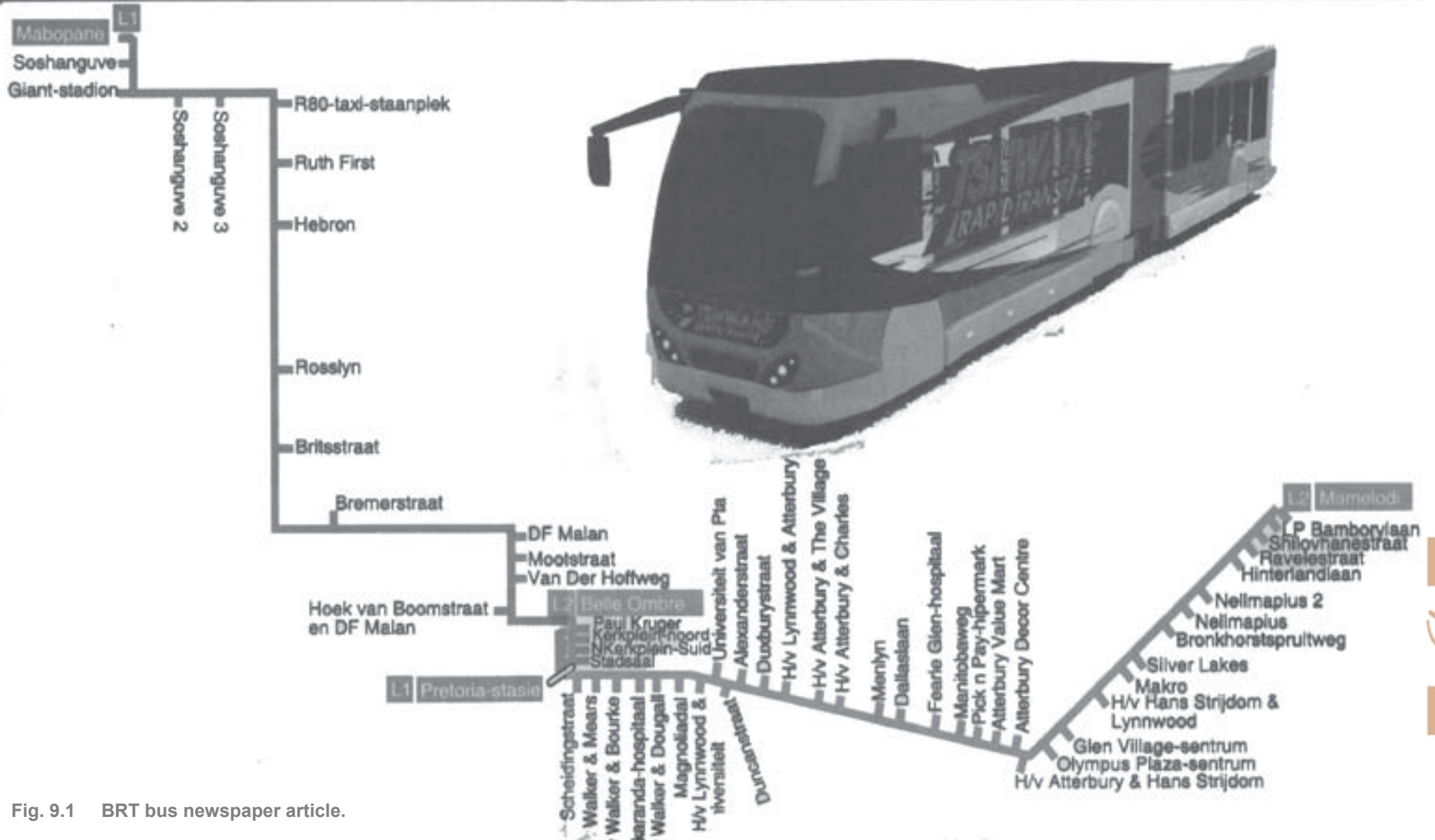
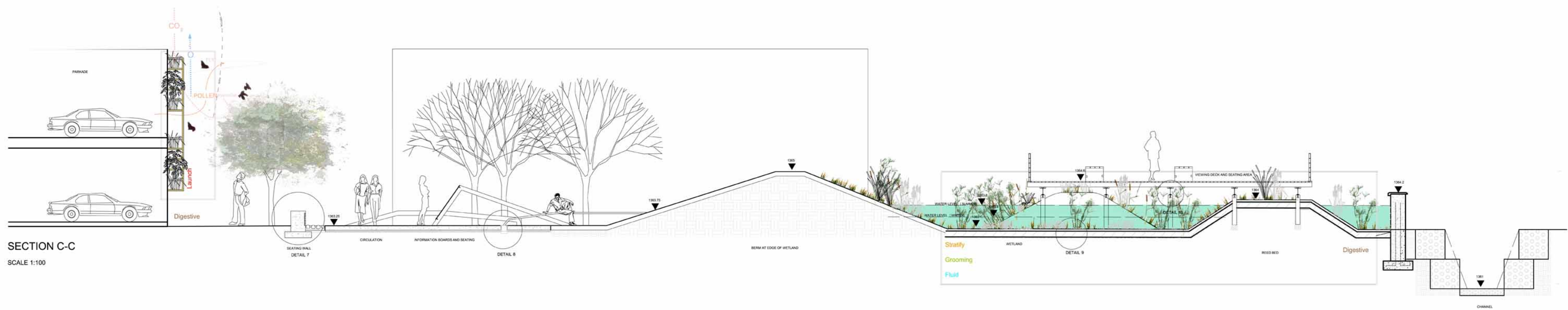
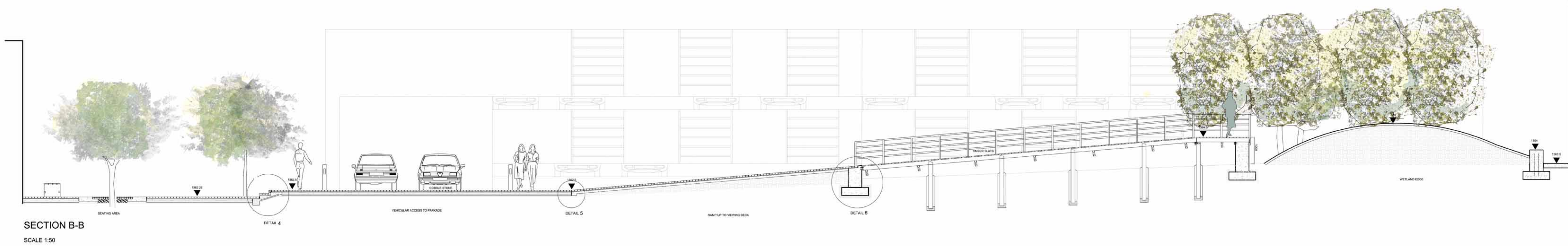
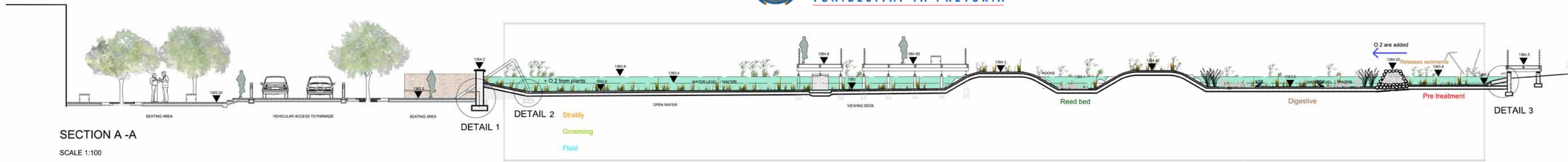
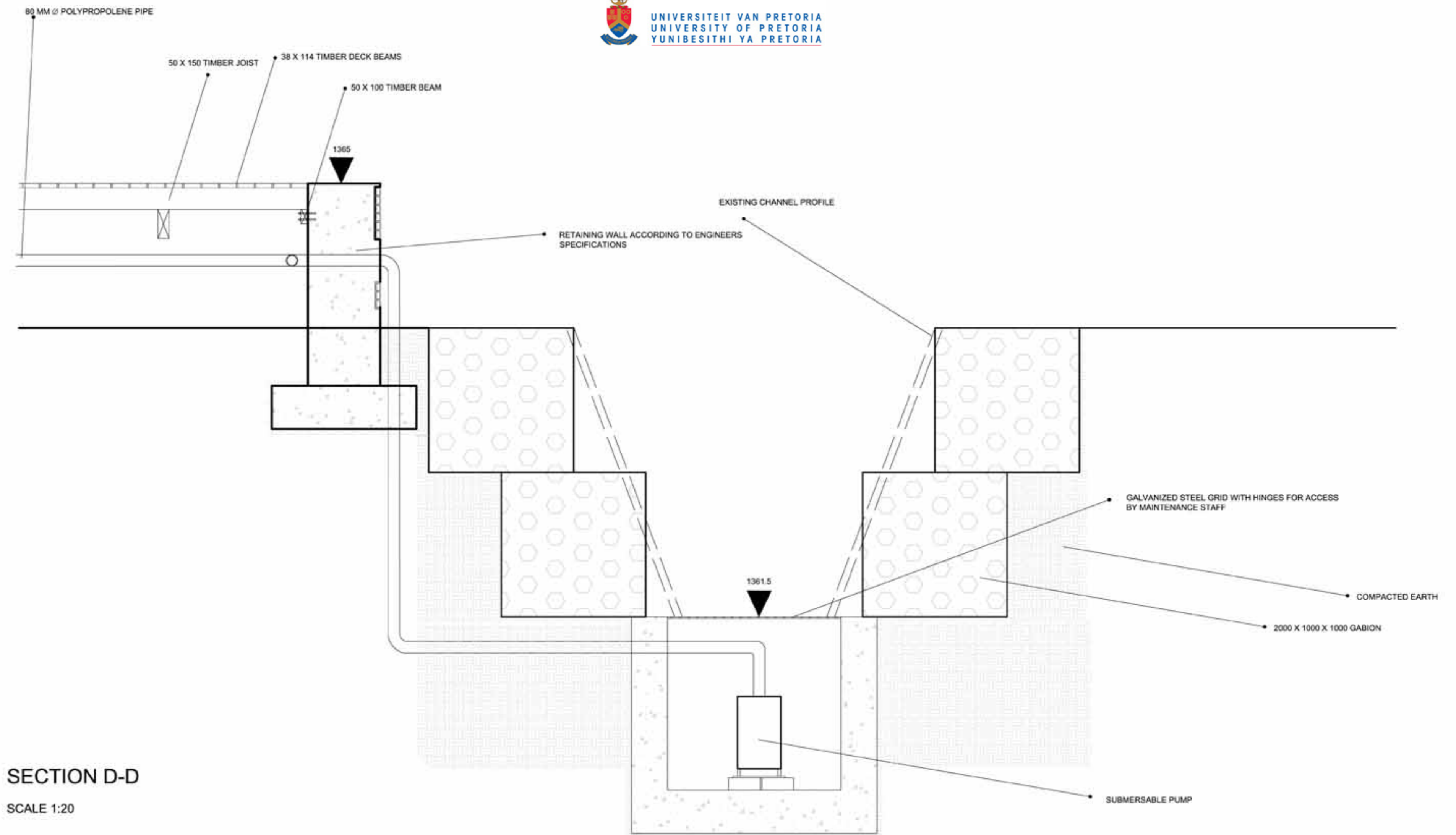

Fig. 9.1 BRT bus newspaper article.







SECTION D-D

SCALE 1:20

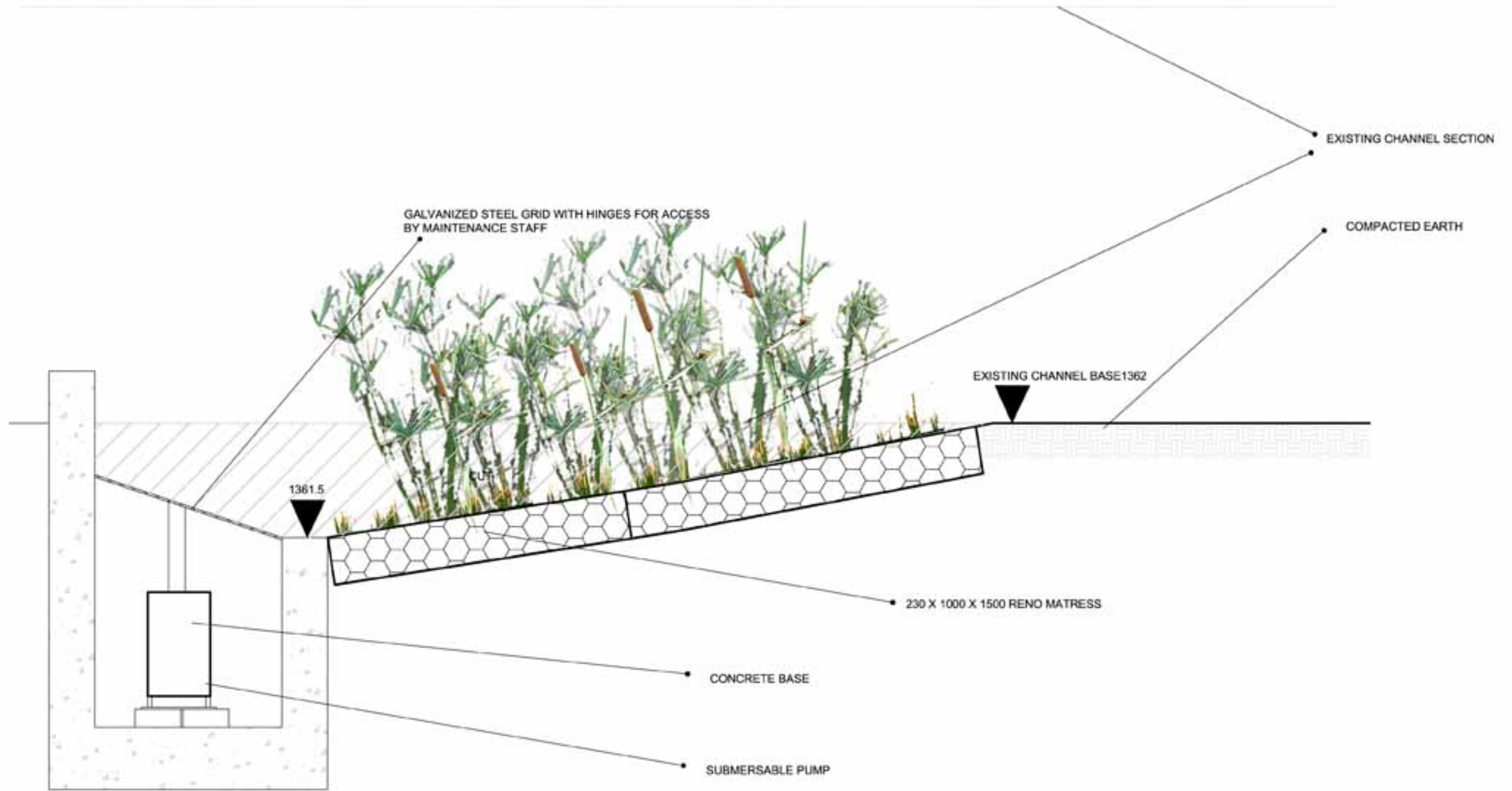

SECTION E-E

SCALE 1:20

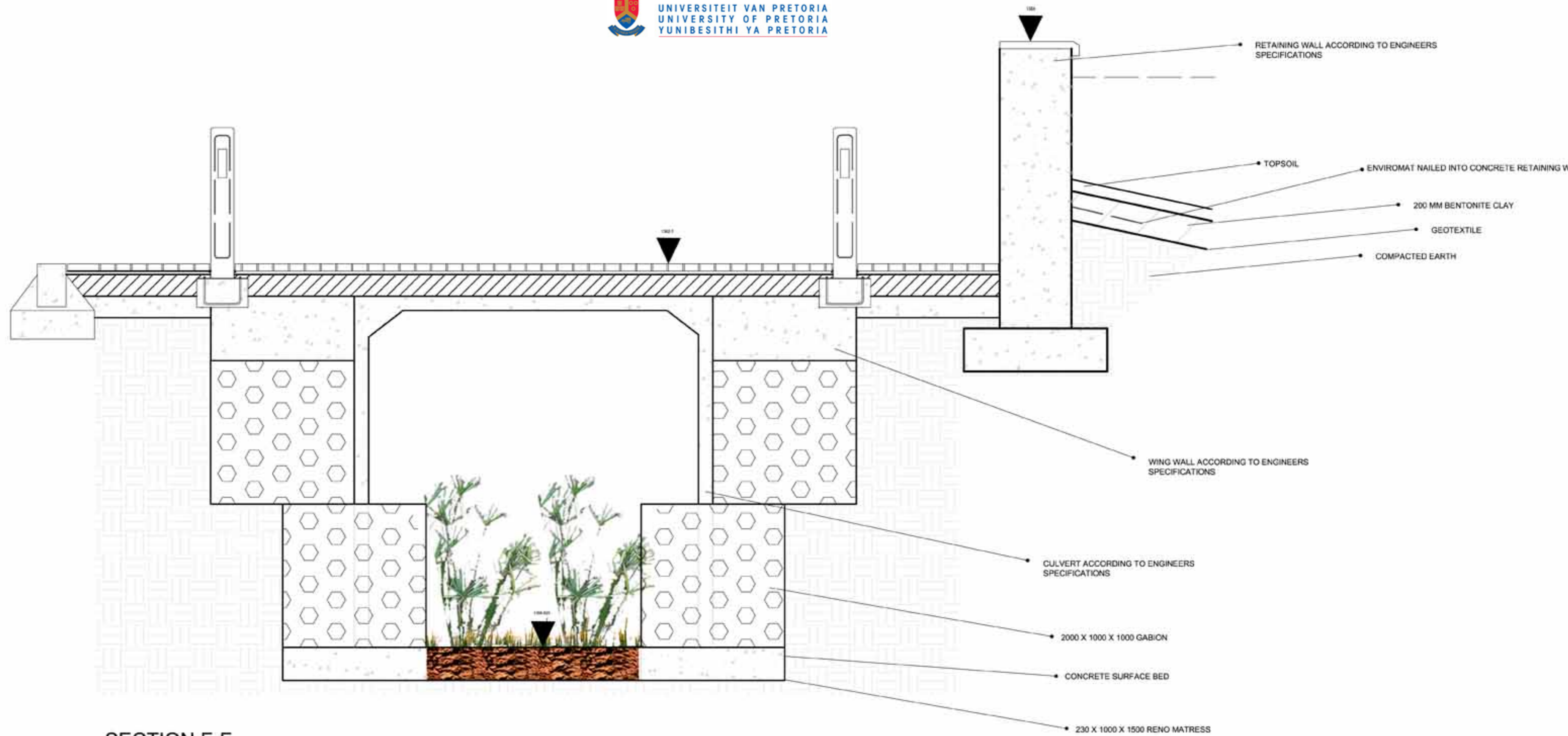

SECTION F-F

SCALE 1: 20

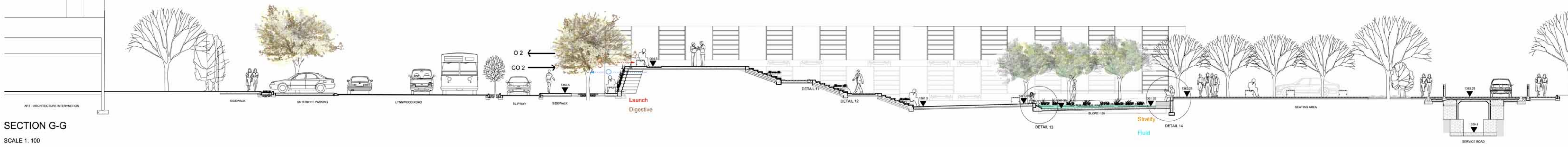

SECTION G-G  
SCALE 1: 100

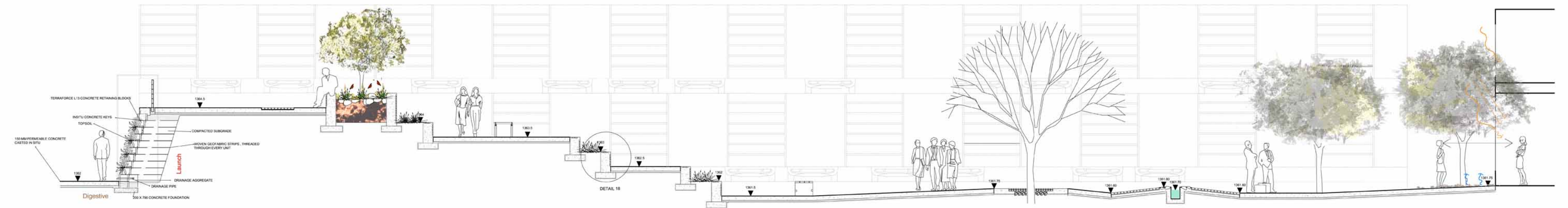

SECTION I-I



SECTION L-L  
SCALE 1:50

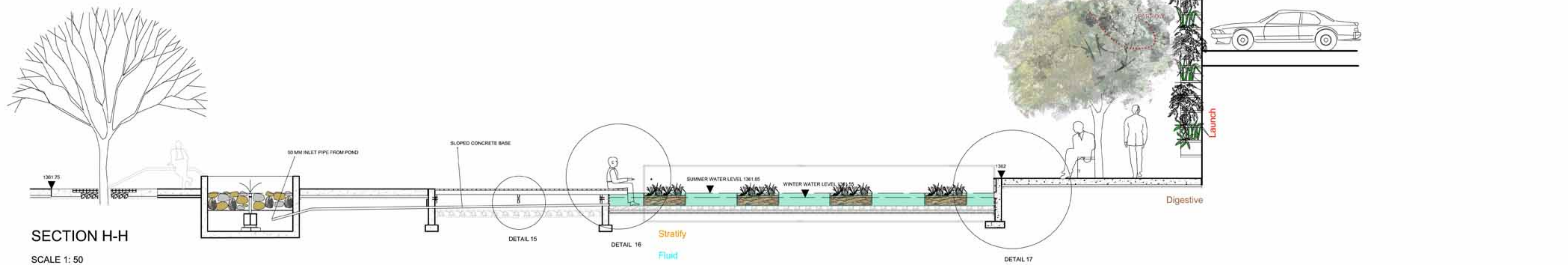

SECTION H-H  
SCALE 1: 50

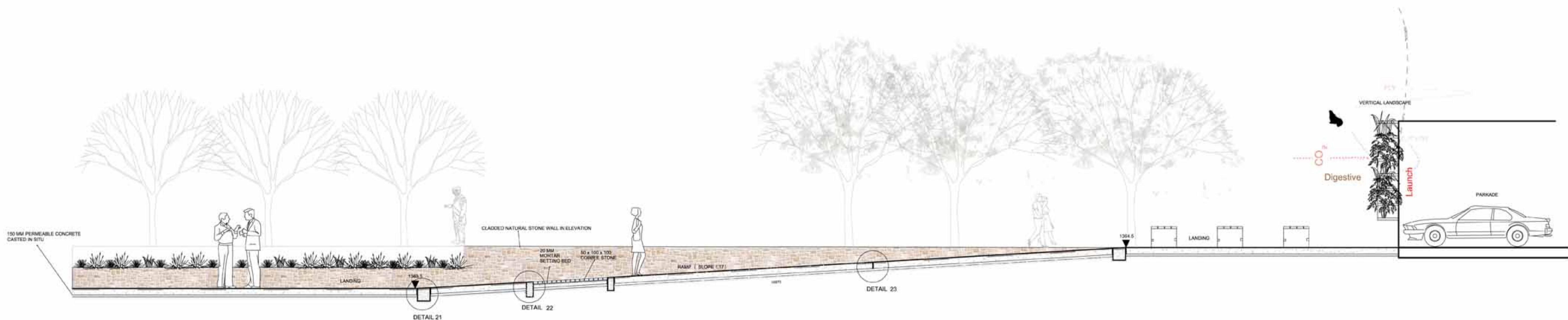

SECTION M-M  
SCALE 1: 50

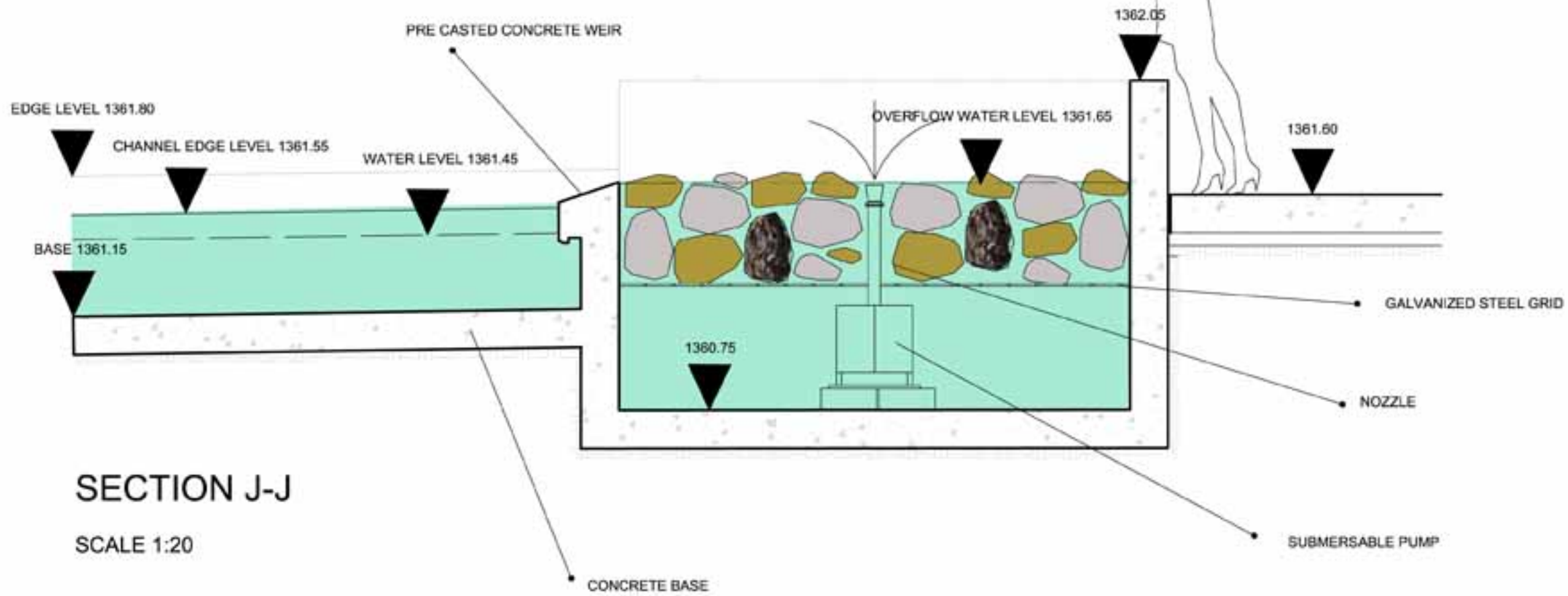

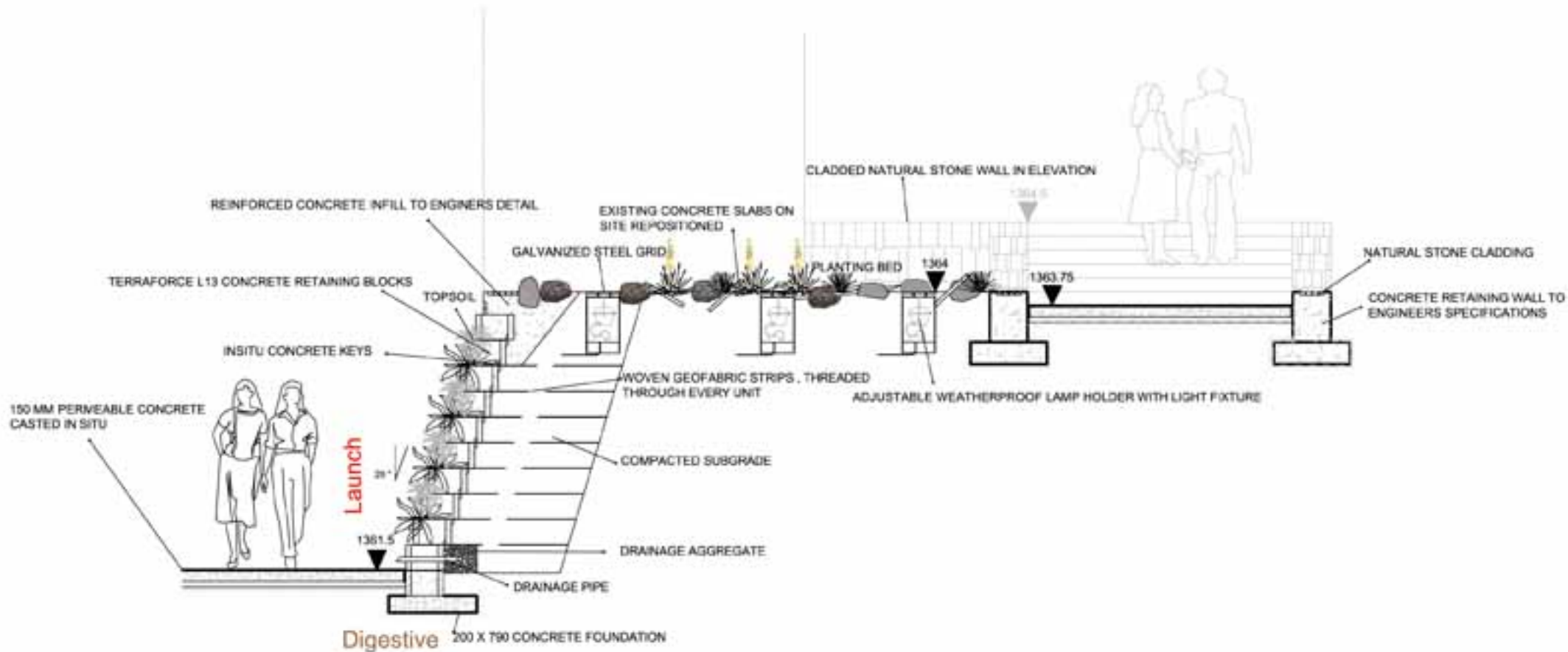

## SECTION N - N

SCALE 1: 50



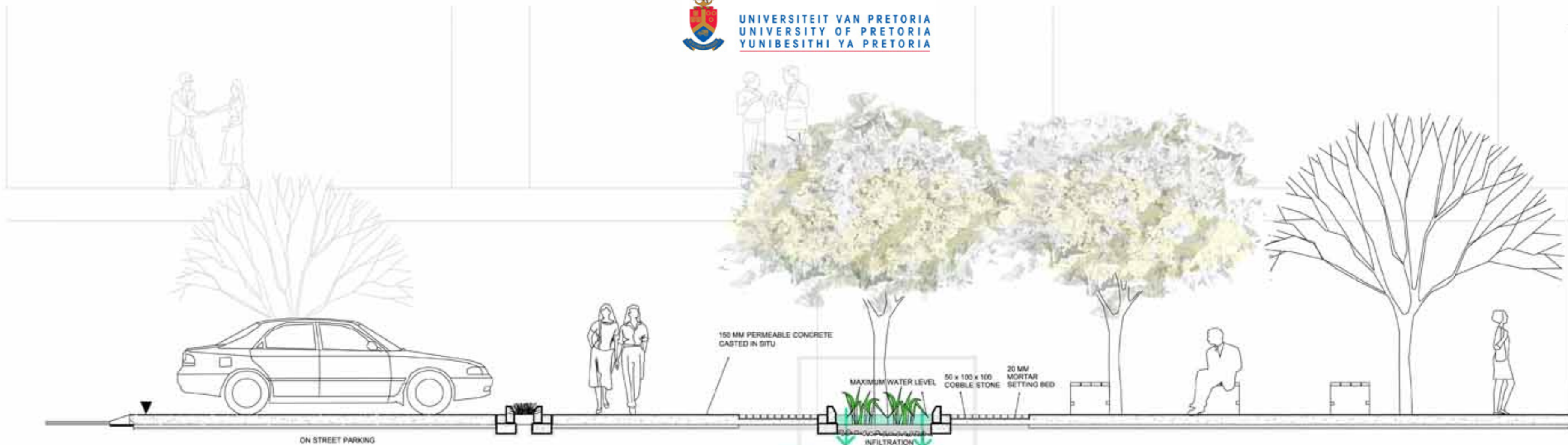

SECTION O-O

SCALE 1: 50

Stratify  
Fluid  
Digestive

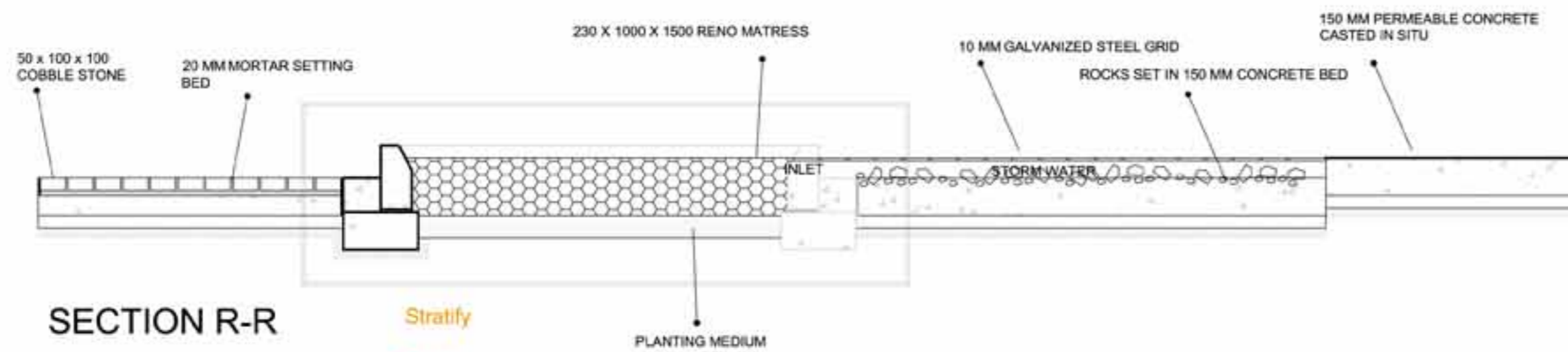

SECTION R-R

SCALE 1: 20

Stratify  
Fluid

TOWN AND CITY PLANNING DEPARTMENT

ART HISTORY

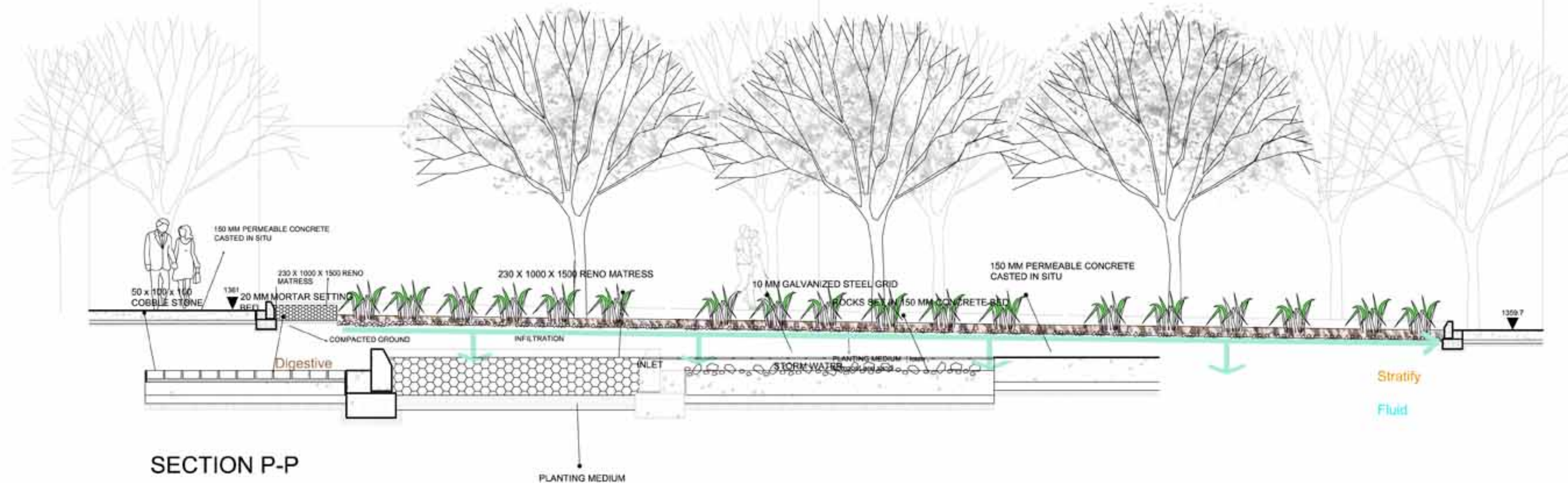

SECTION P-P

SCALE 1: 50

PLANTING MEDIUM

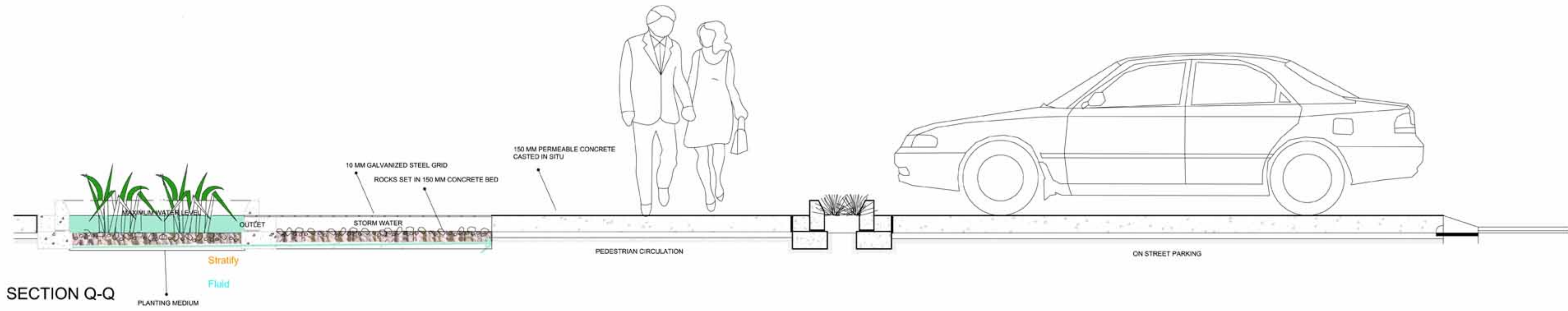

SECTION Q-Q

SCALE 1: 20

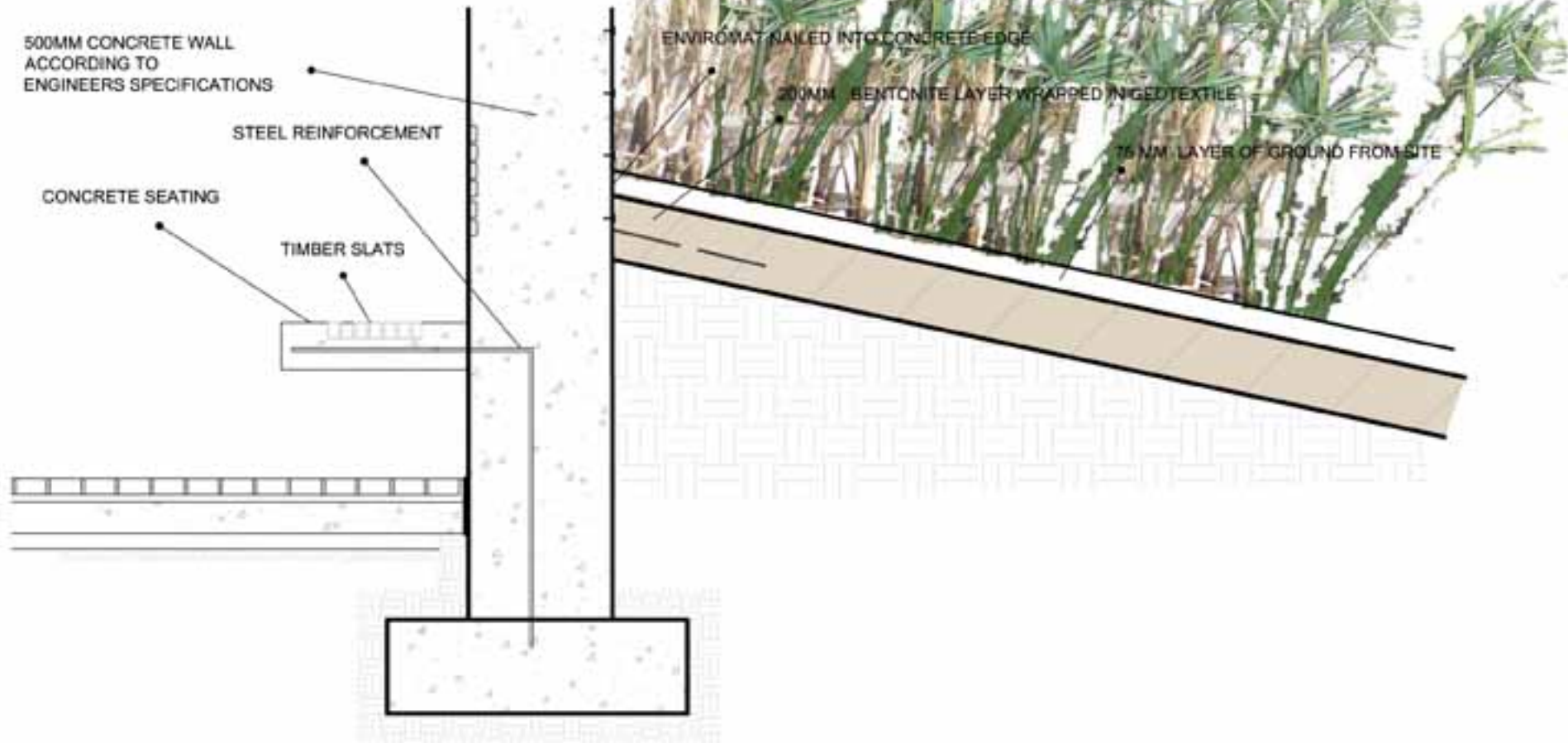

## DETAIL 1

SCALE 1:20

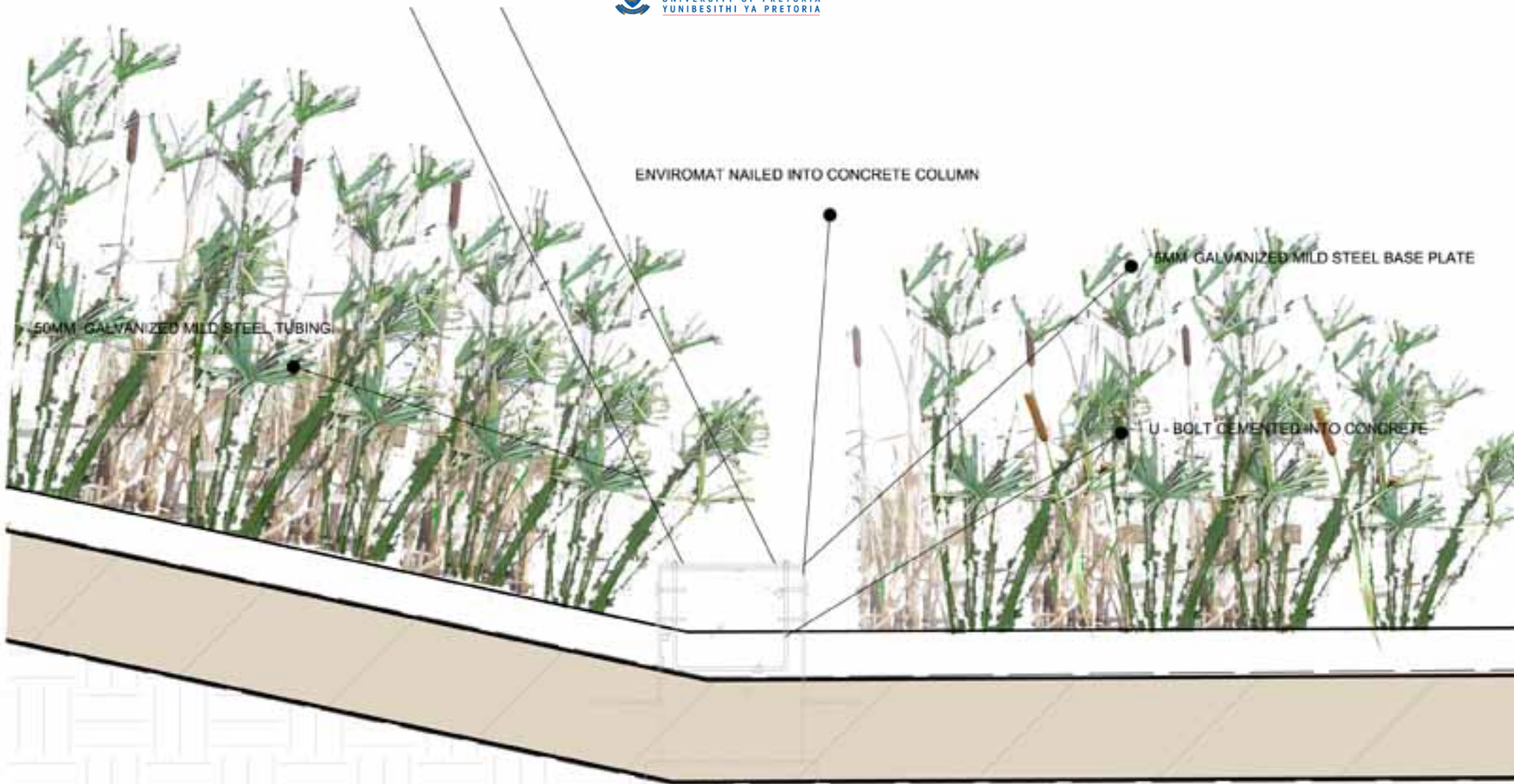

## DETAIL 2

SCALE 1:10



80 MM Ø POLYPROPYLENE PIPE



UNIVERSITEIT VAN PRETORIA  
UNIVERSITY OF PRETORIA  
YUNIBESITHI YA PRETORIA

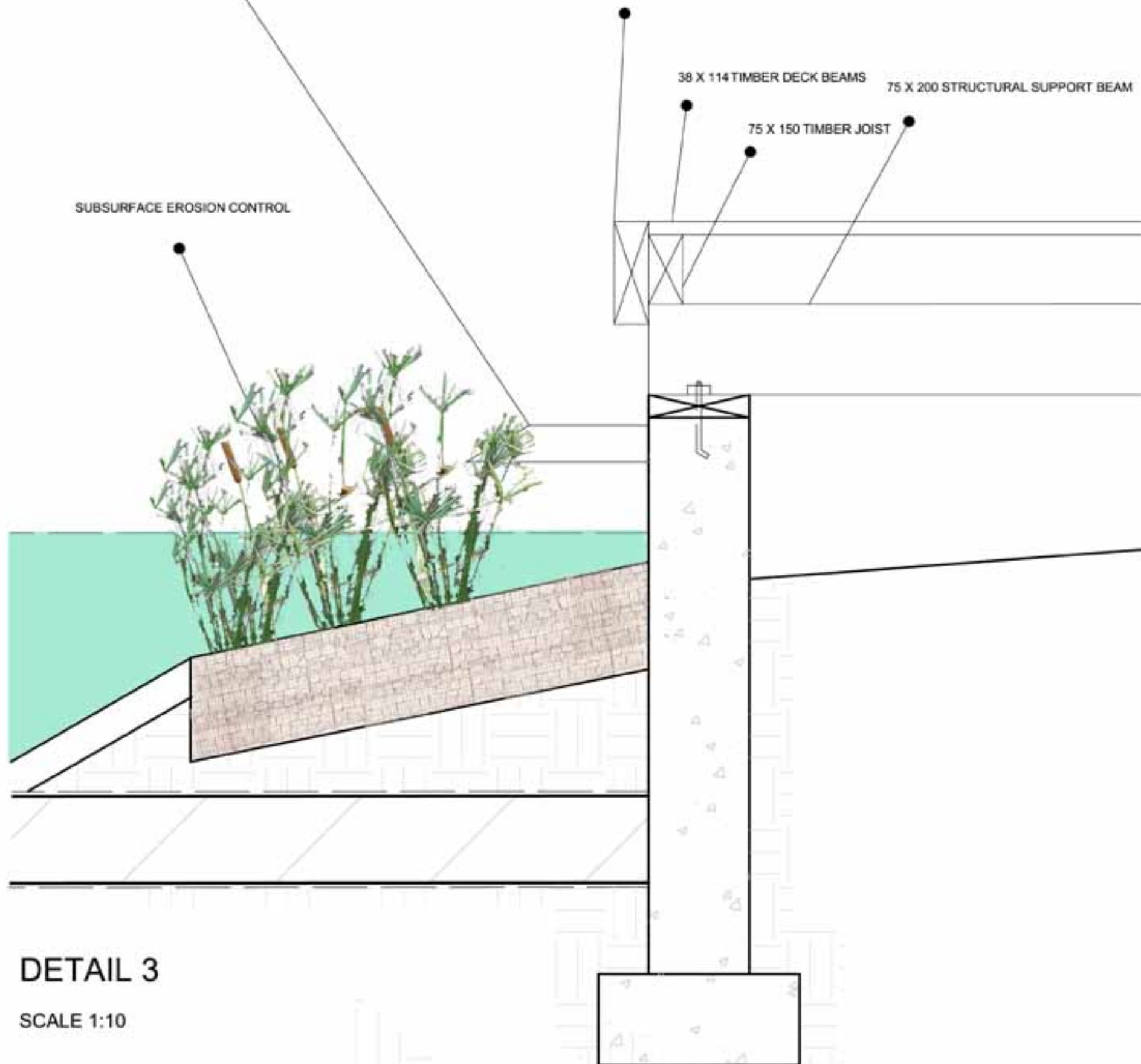

DETAIL 3

SCALE 1:10

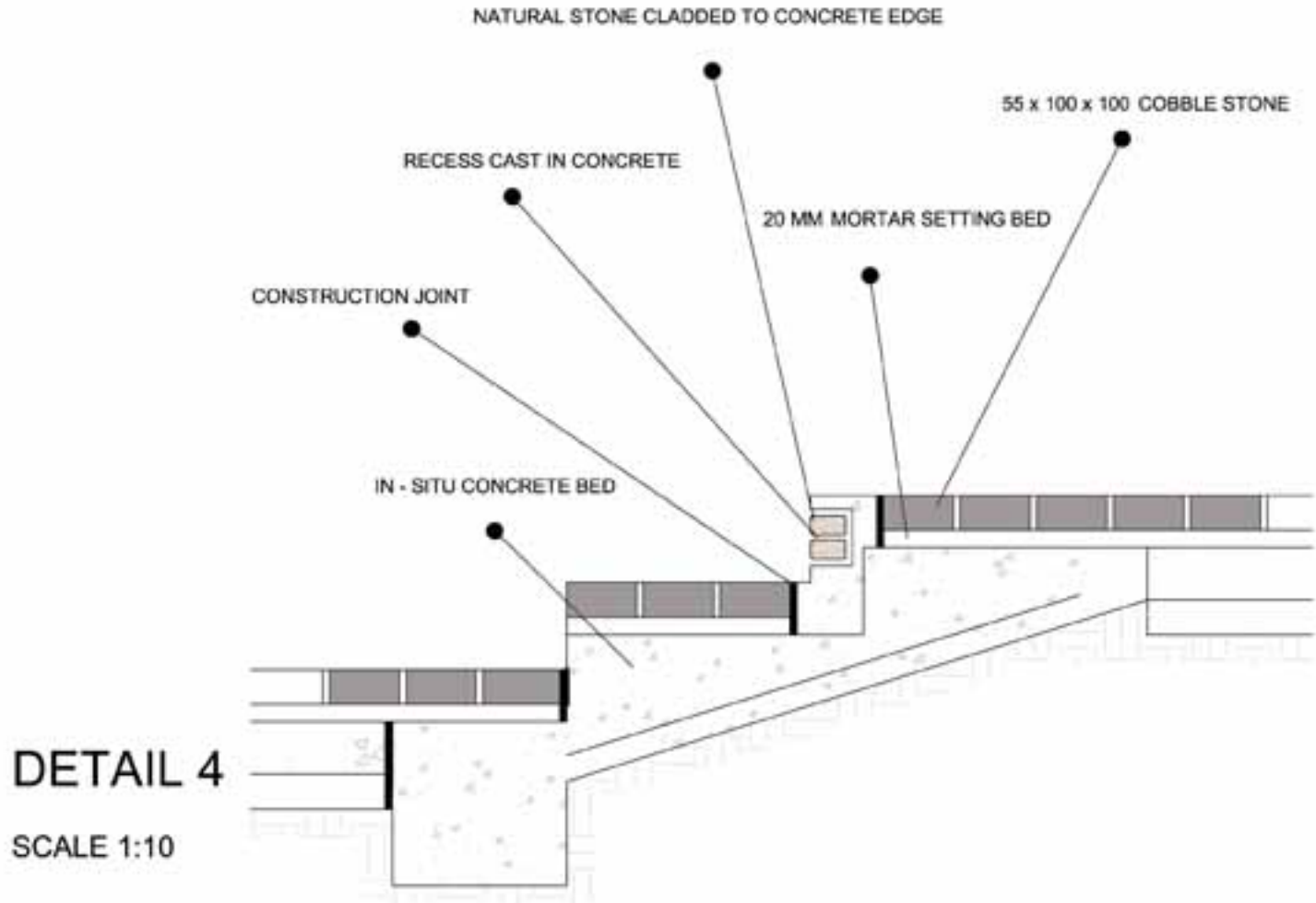

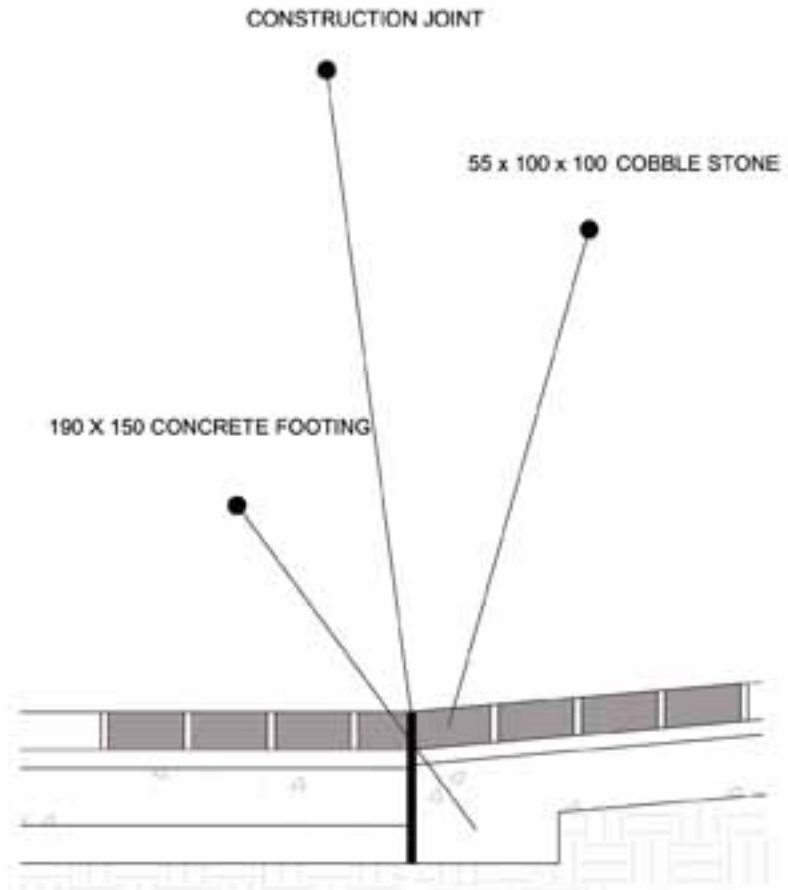

DETAIL 5

SCALE 1:10



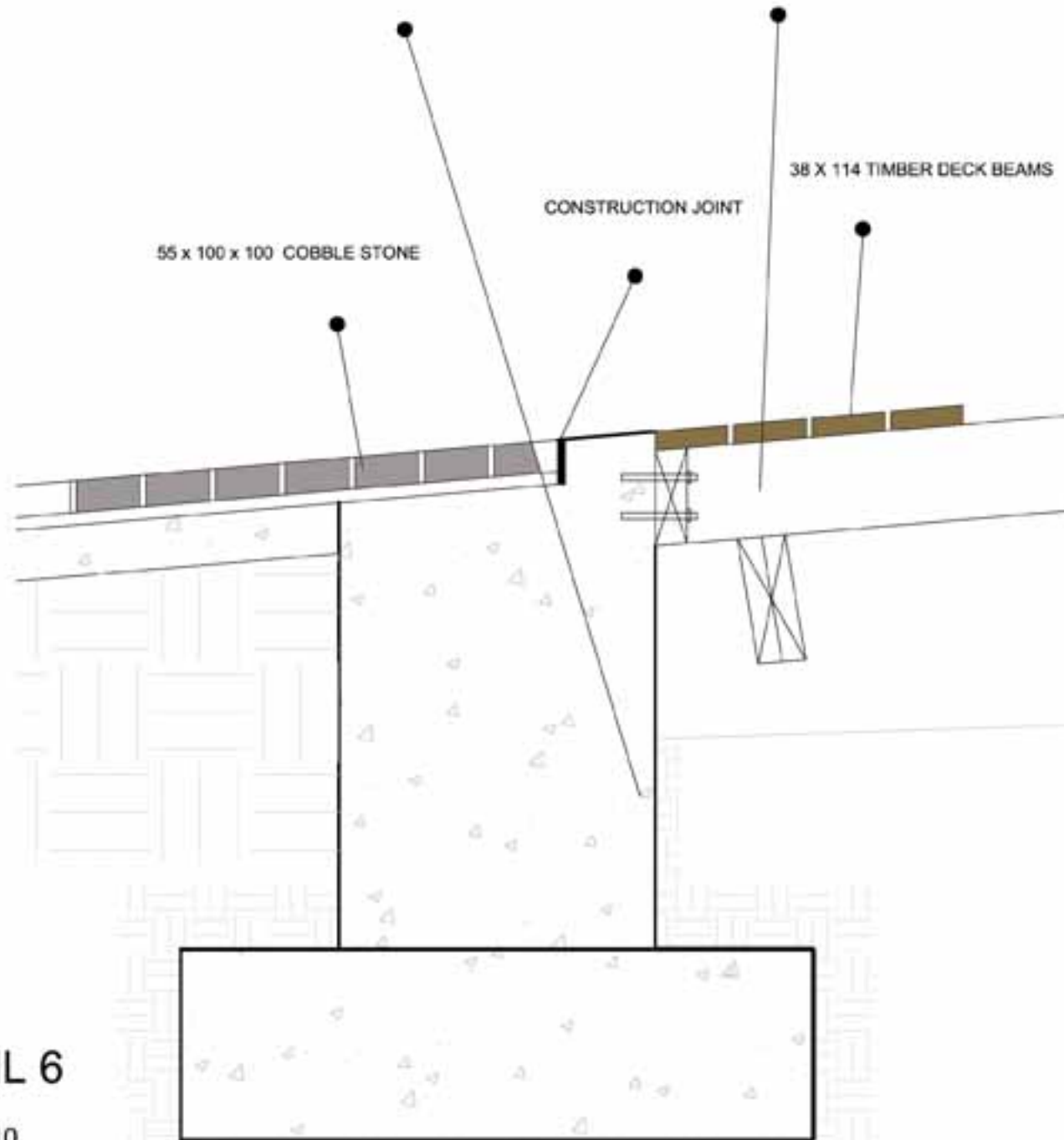

DETAIL 6

SCALE 1:10

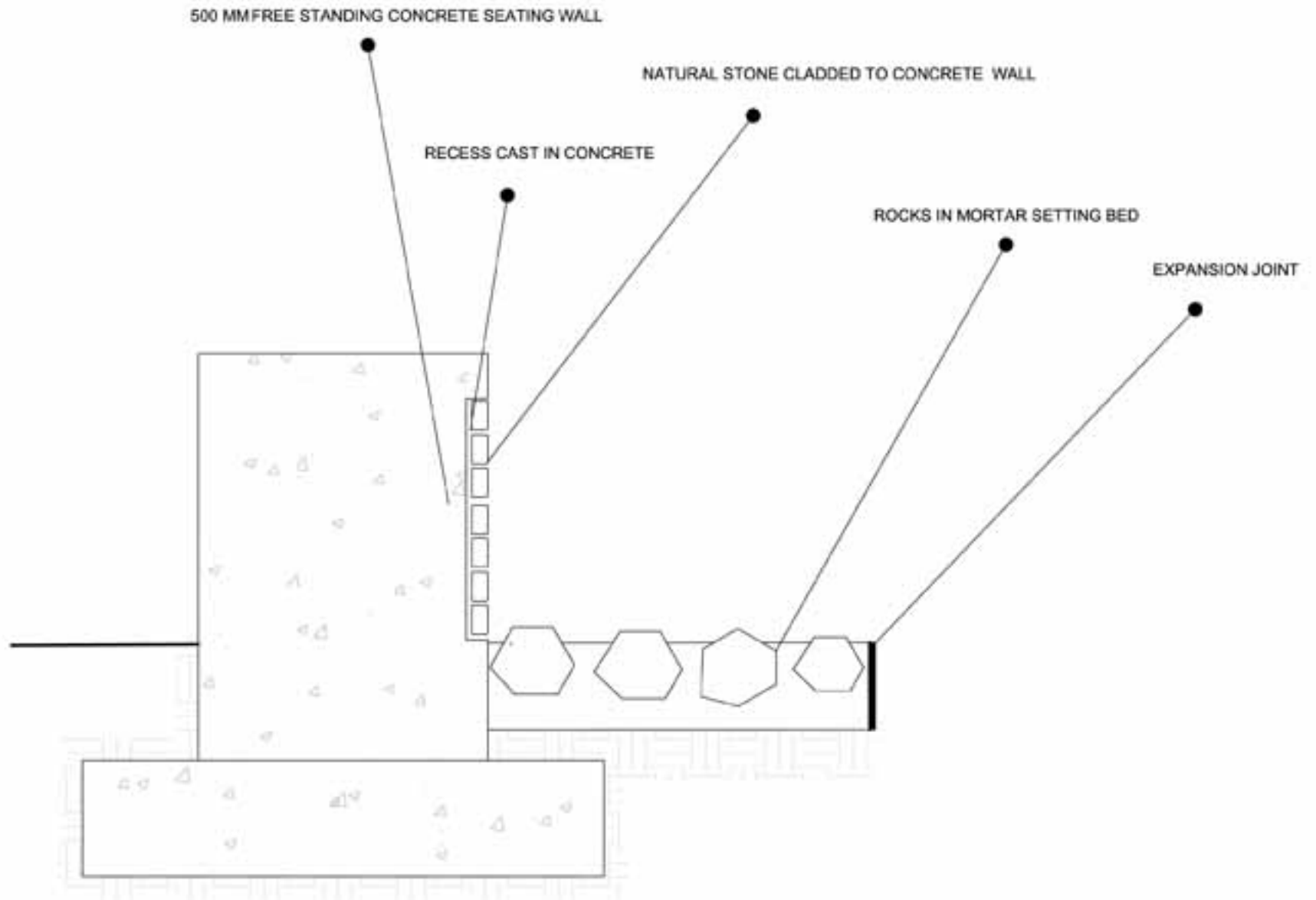

DETAIL 7

SCALE 1:10

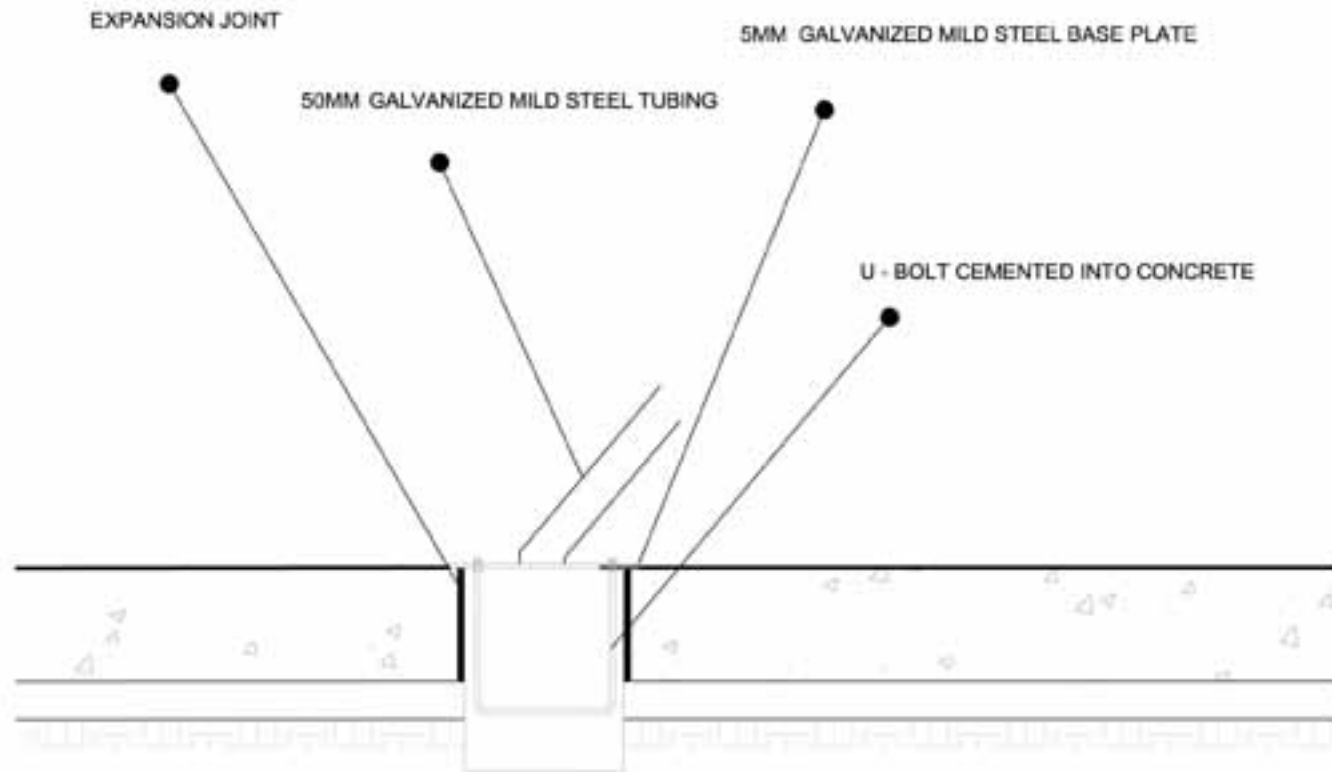

## DETAIL 8

SCALE 1:10

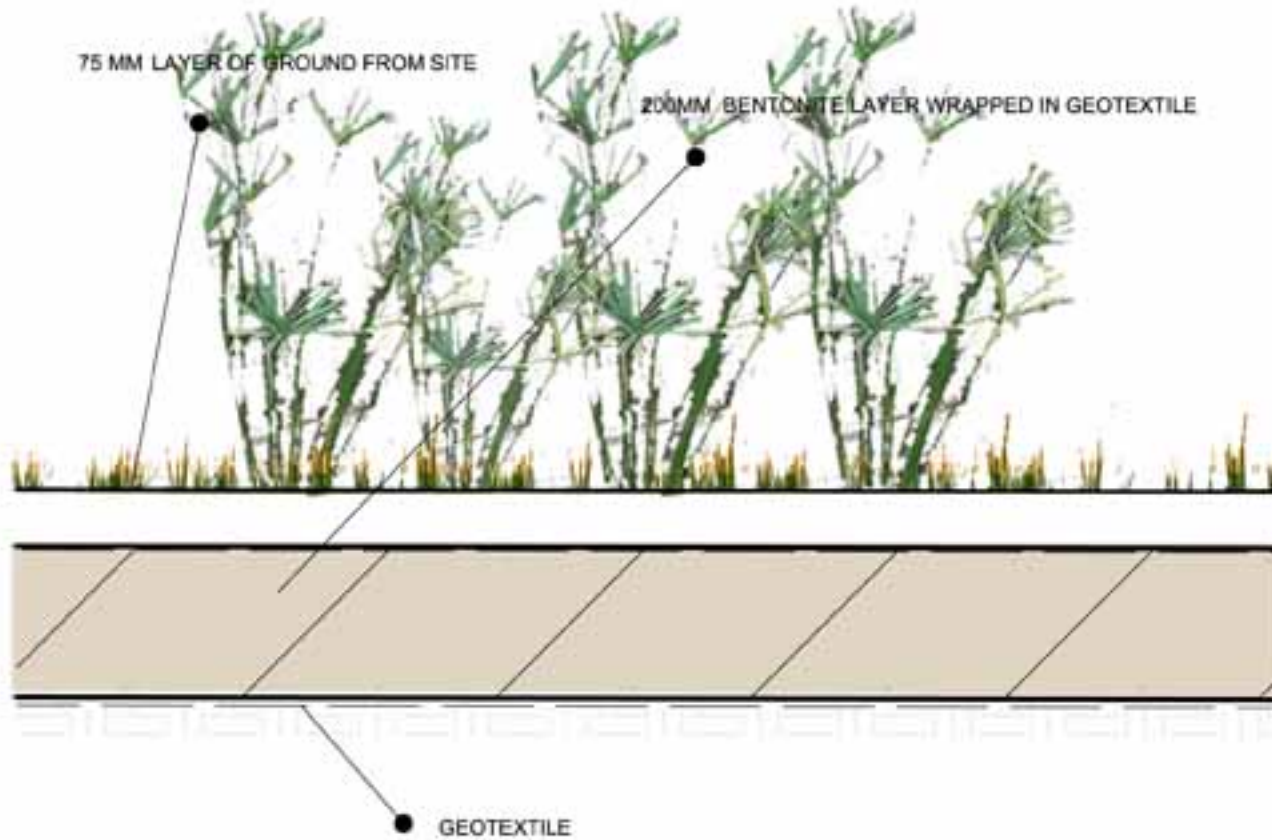

## DETAIL 9

SCALE 1:10

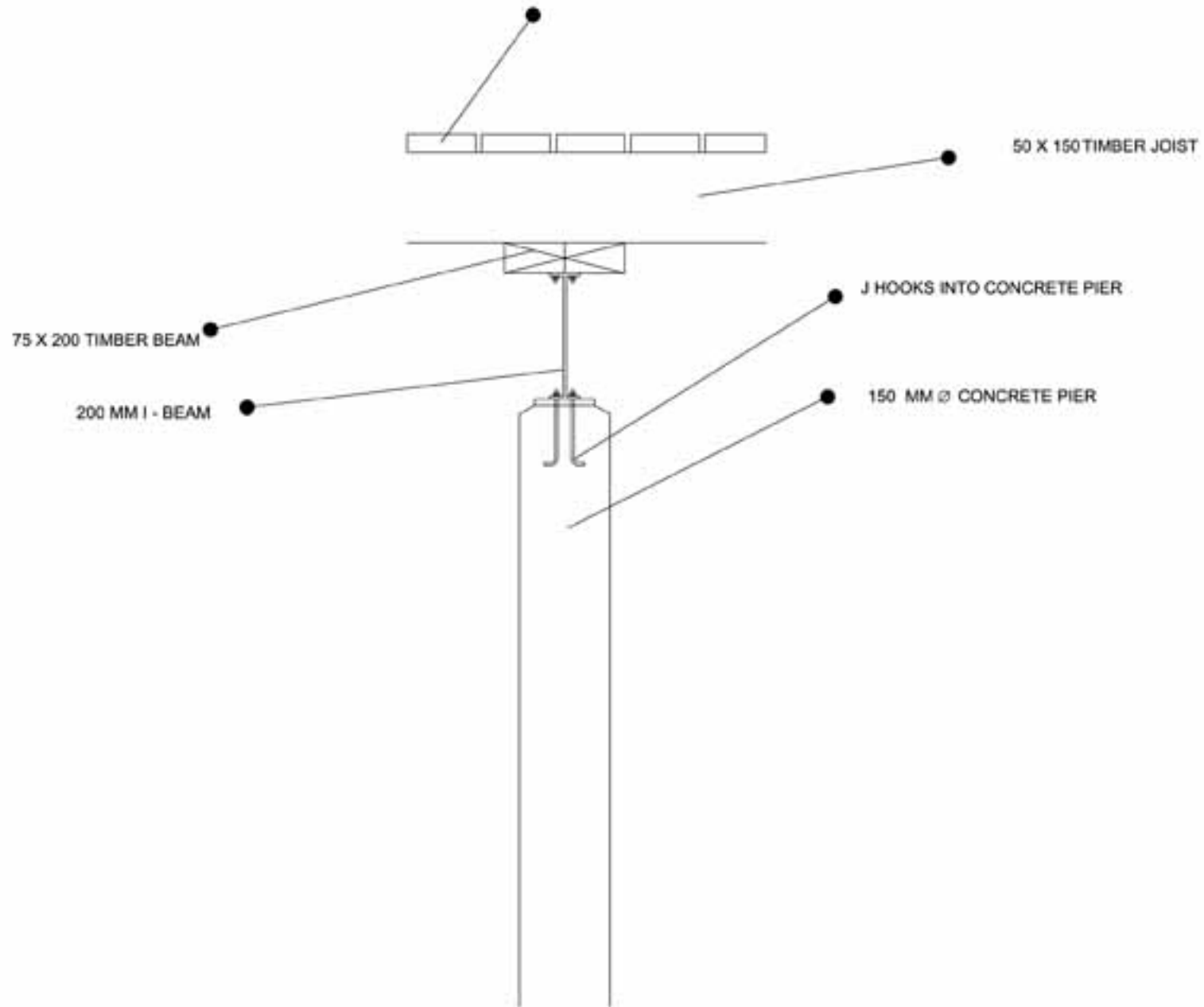

**DETAIL 10**

SCALE 1:10

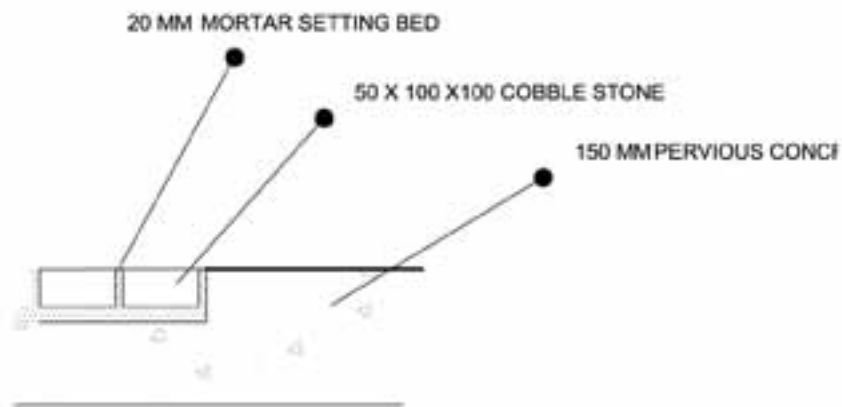

DETAIL 11

SCALE 1:10

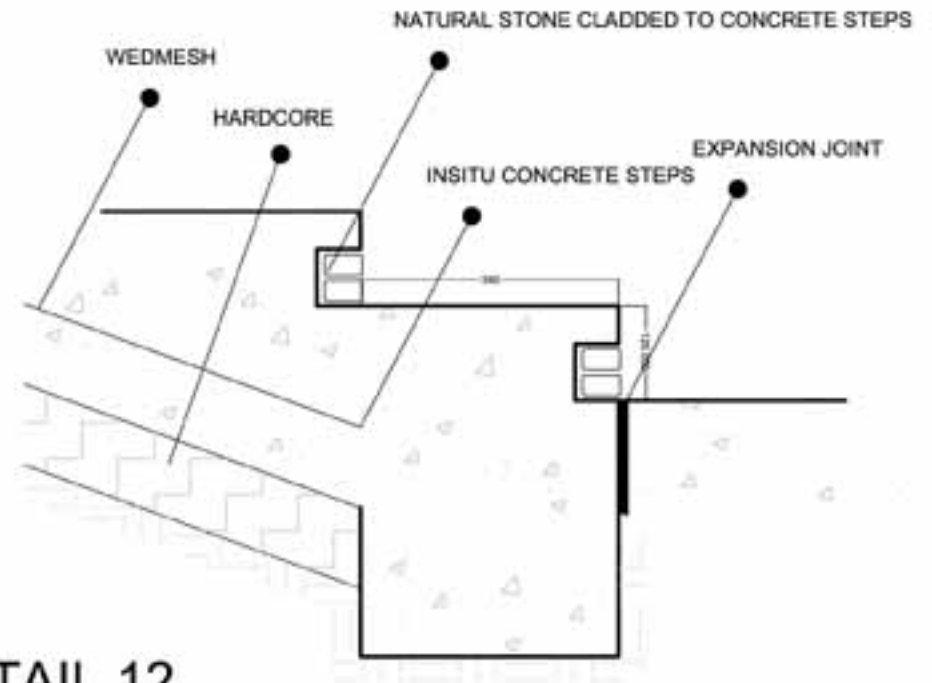

DETAIL 12

SCALE 1:10

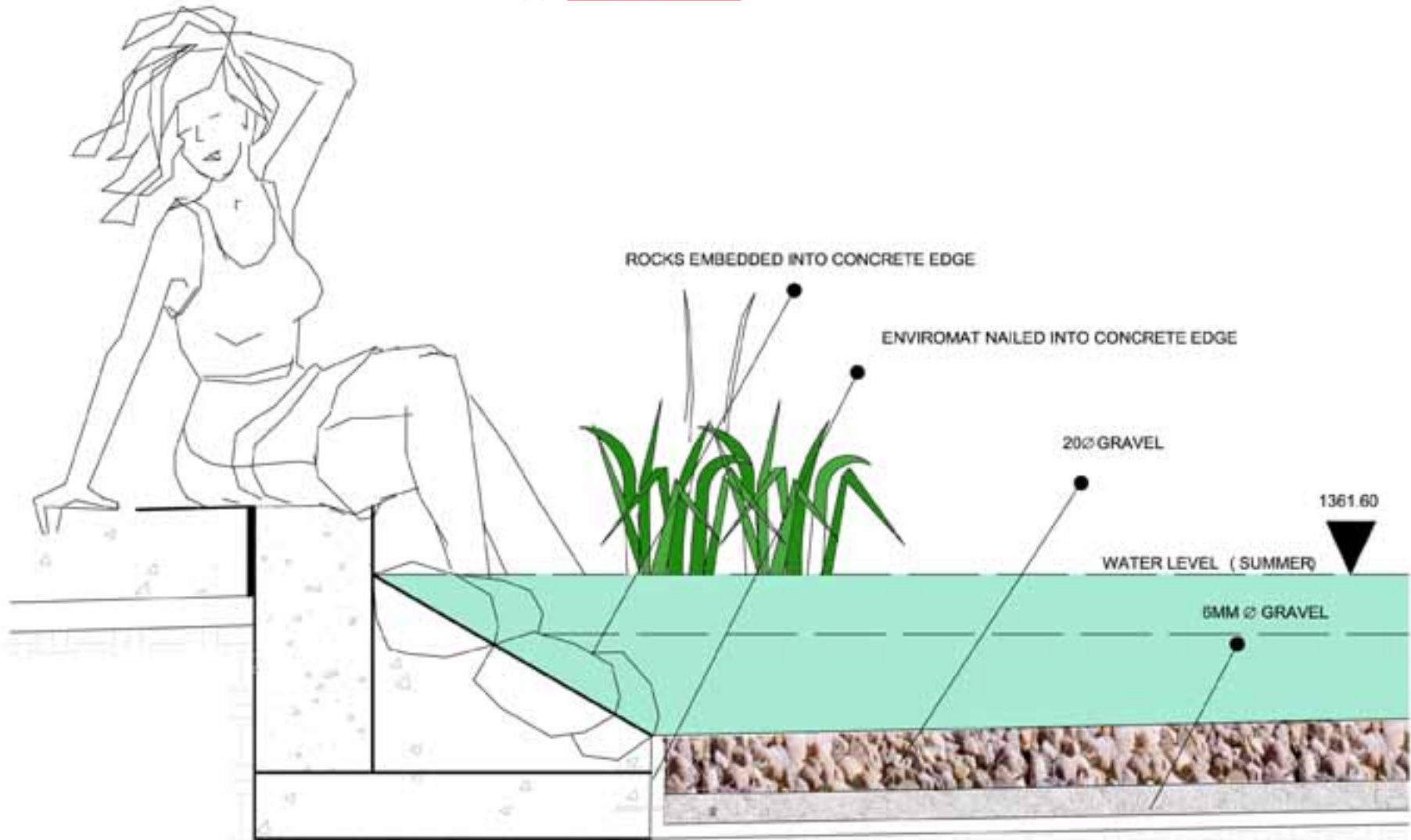

## DETAIL 13

SCALE 1:10

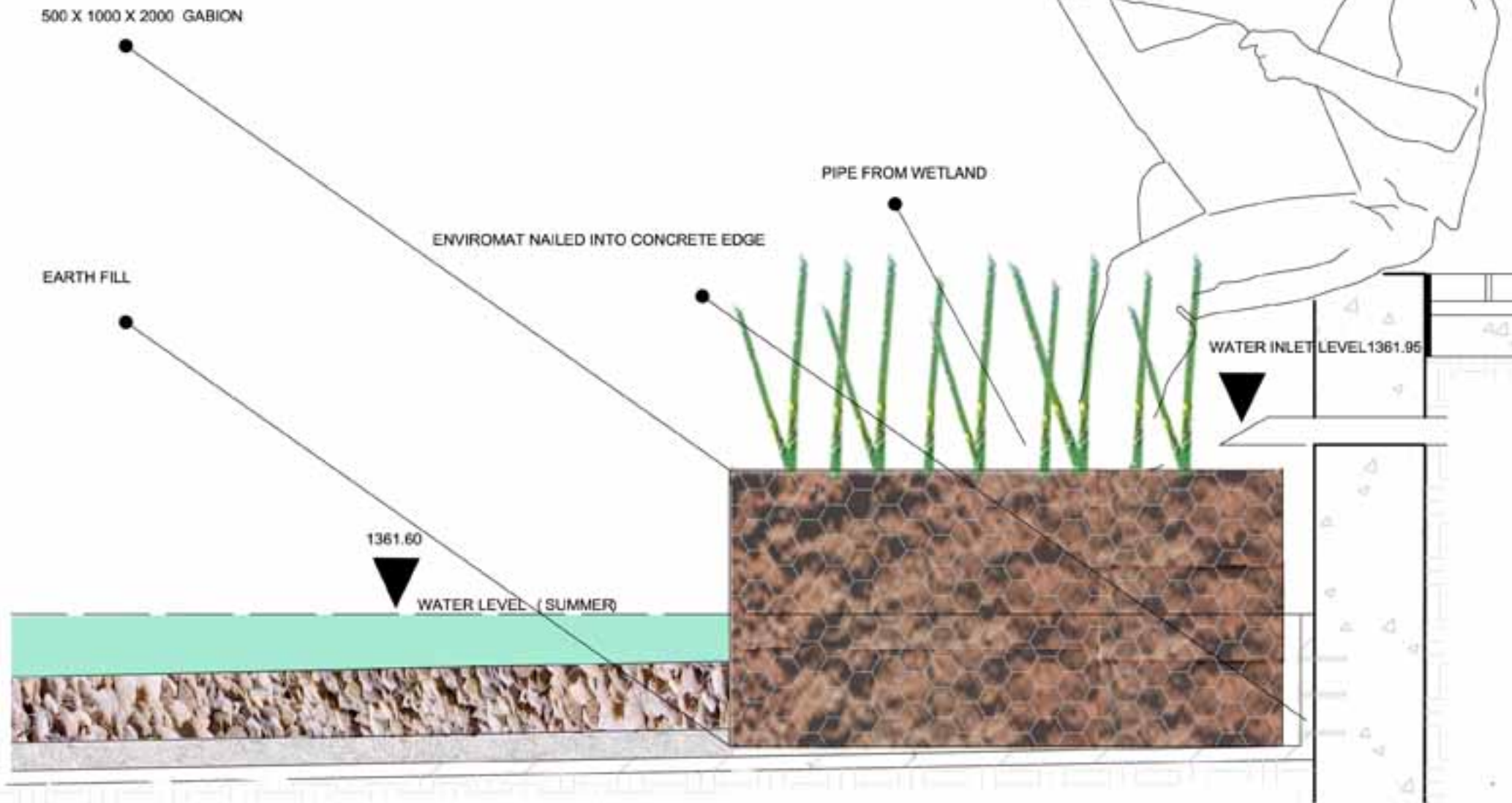

DETAIL 14

SCALE 1:10



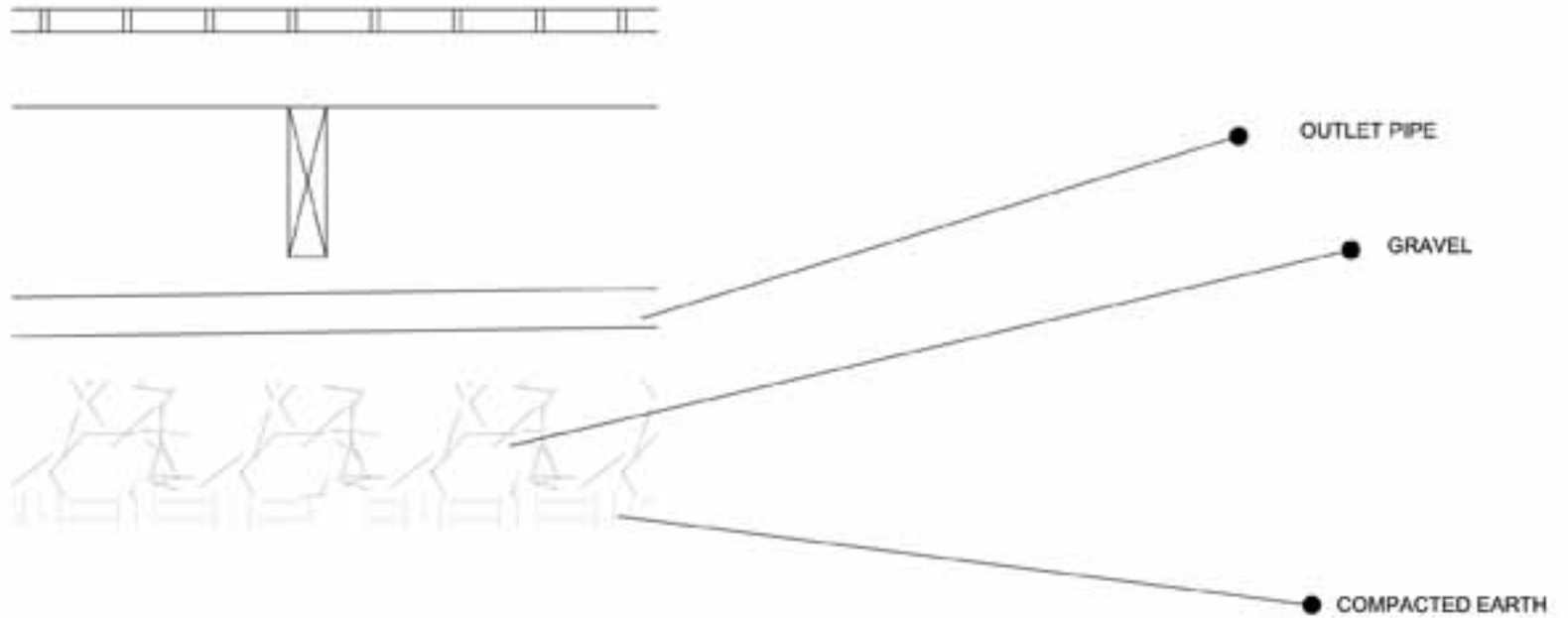

## DETAIL 15

SCALE 1:10

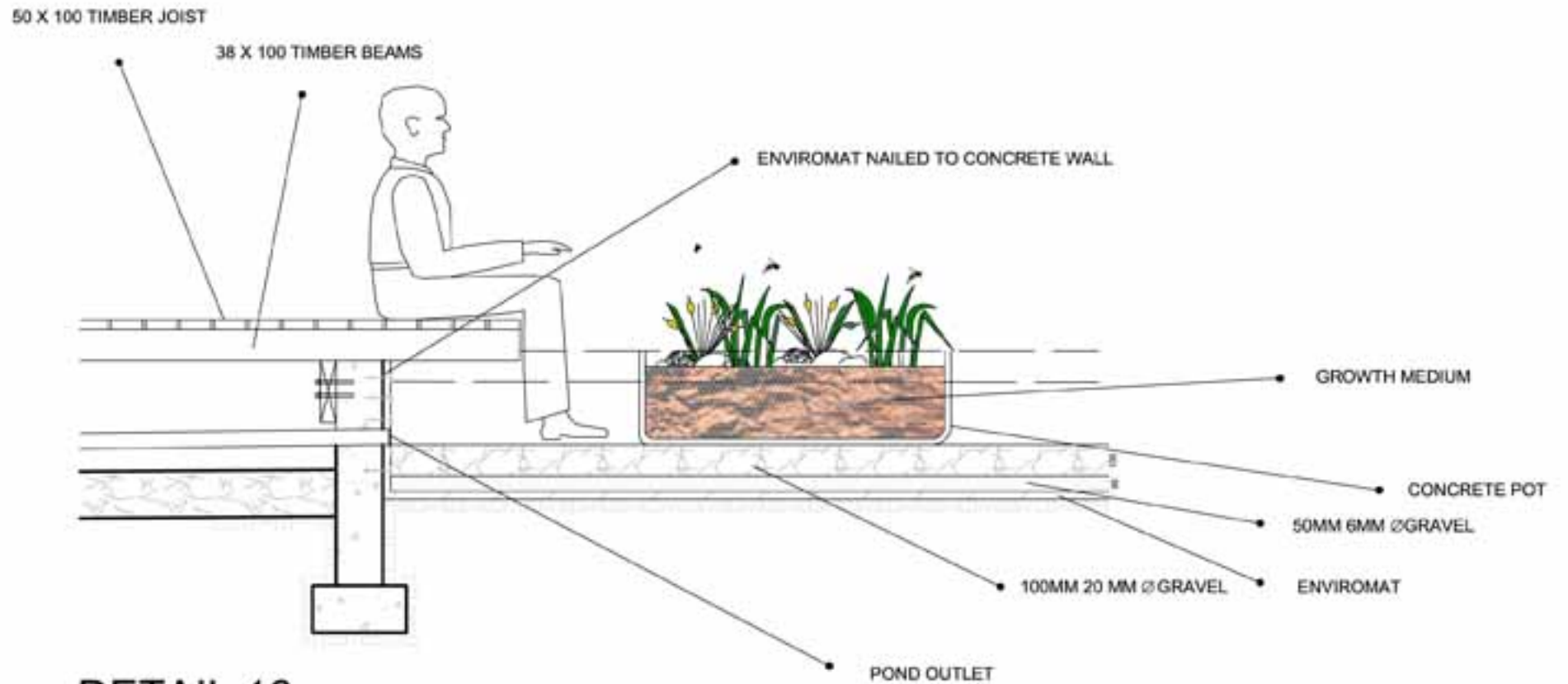

## DETAIL 16

SCALE 1:20

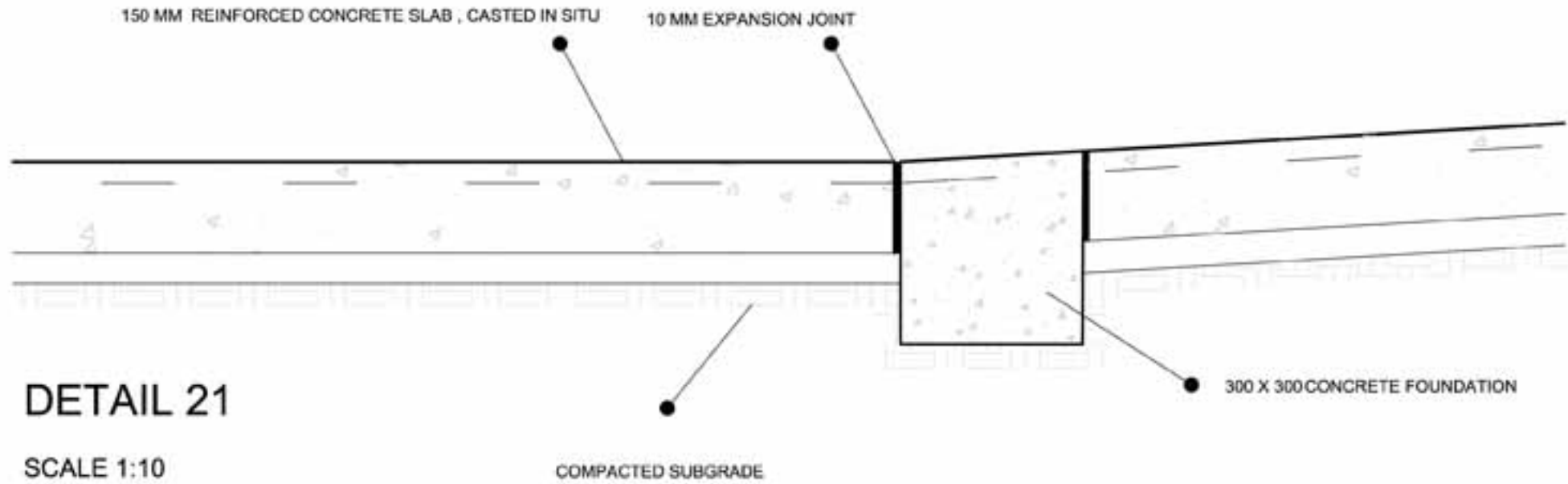

DETAIL 21

SCALE 1:10

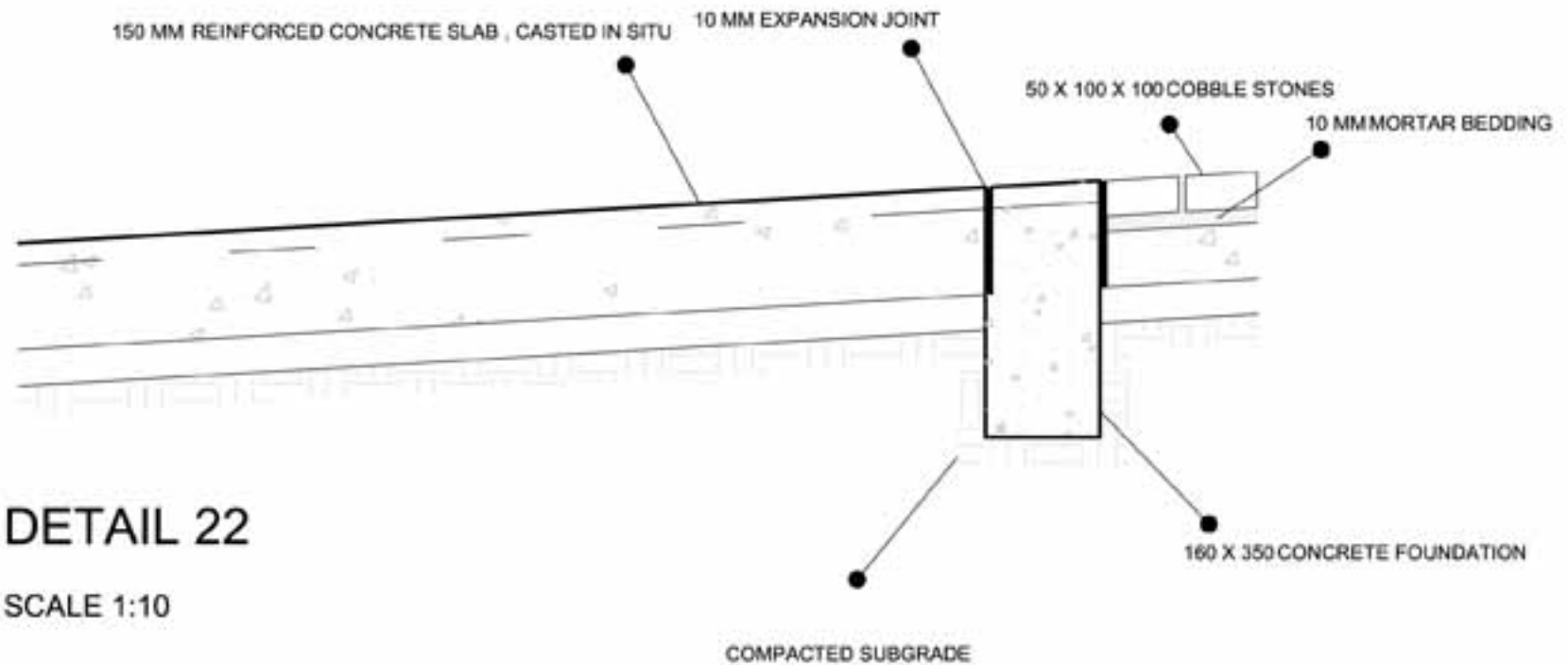

## DETAIL 22

SCALE 1:10

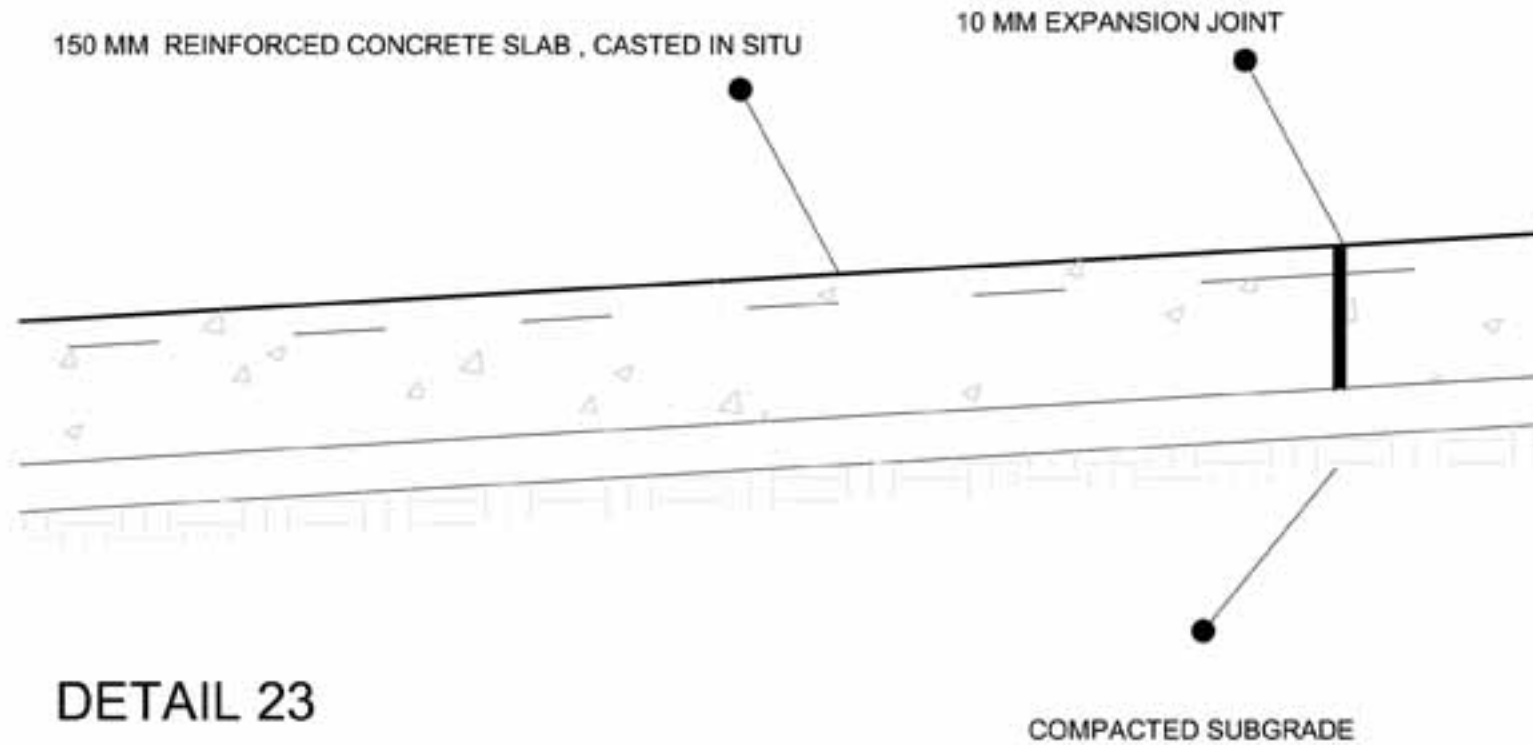

DETAIL 23

SCALE 1:10

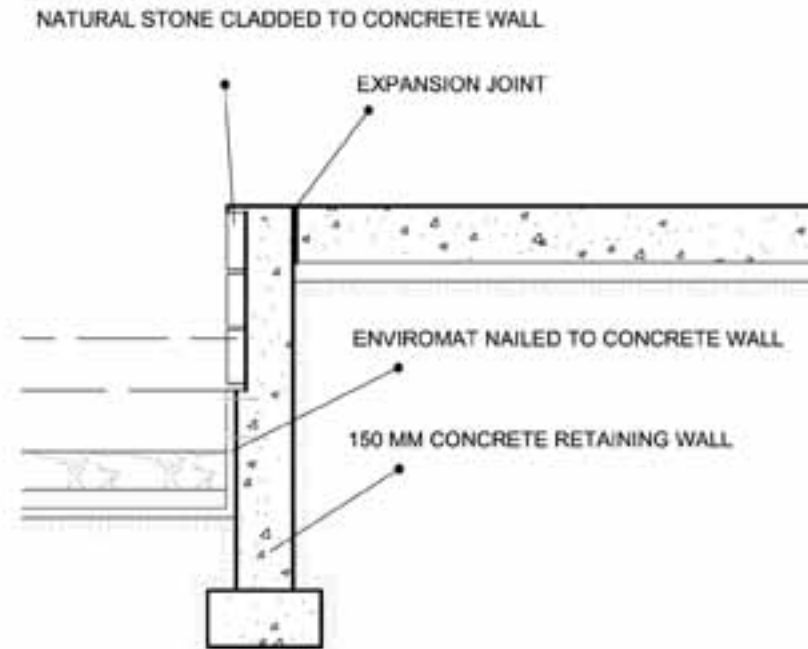

## DETAIL 17

SCALE 1:20

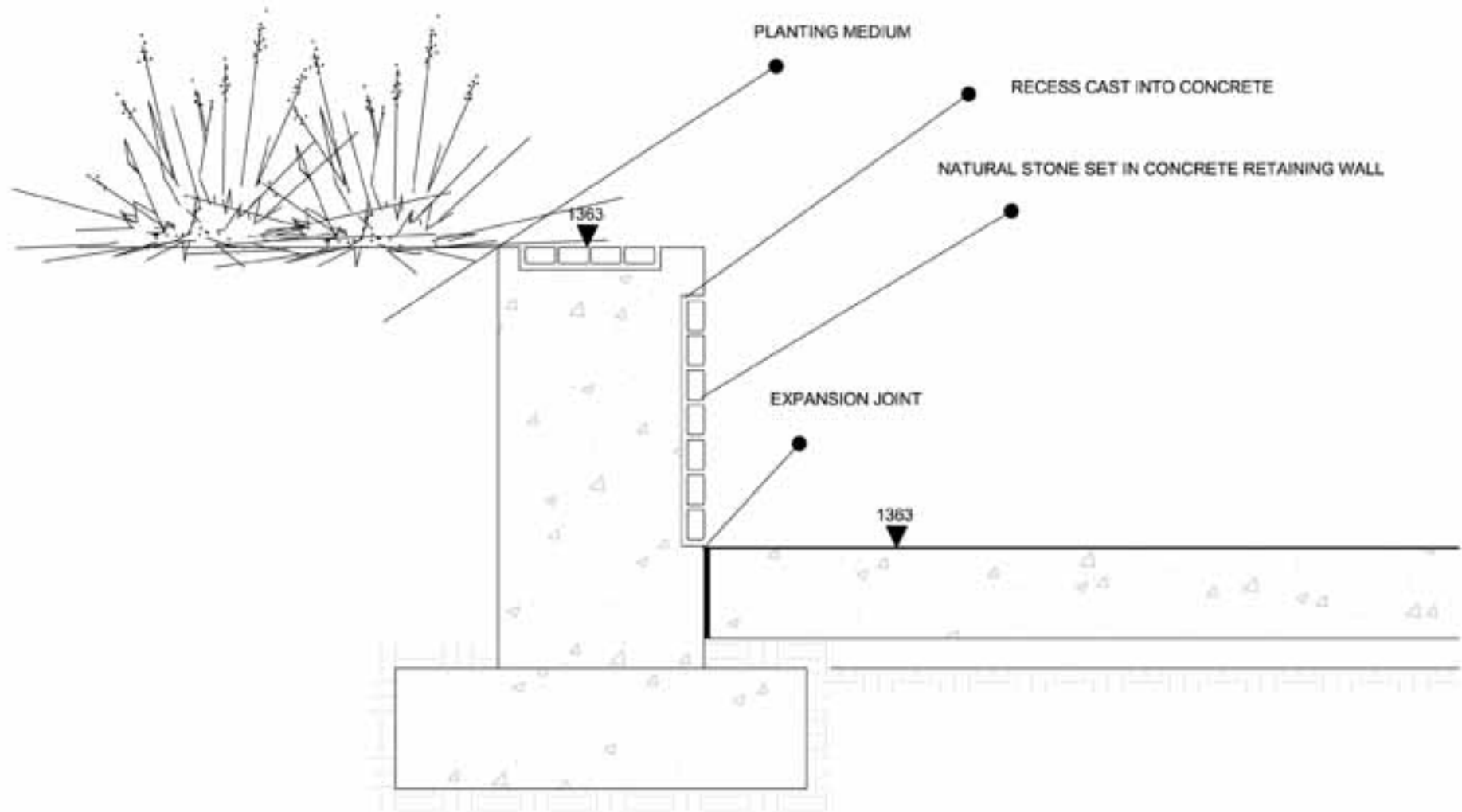

## DETAIL 18

SCALE 1:10

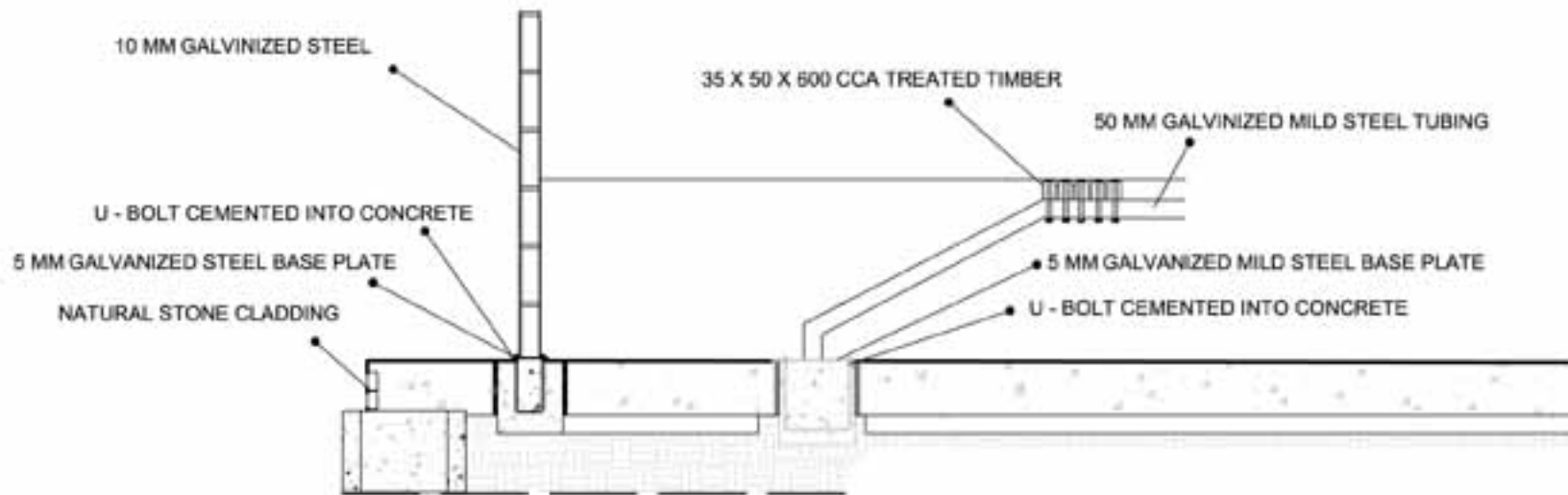

## DETAIL 19

SCALE 1:10



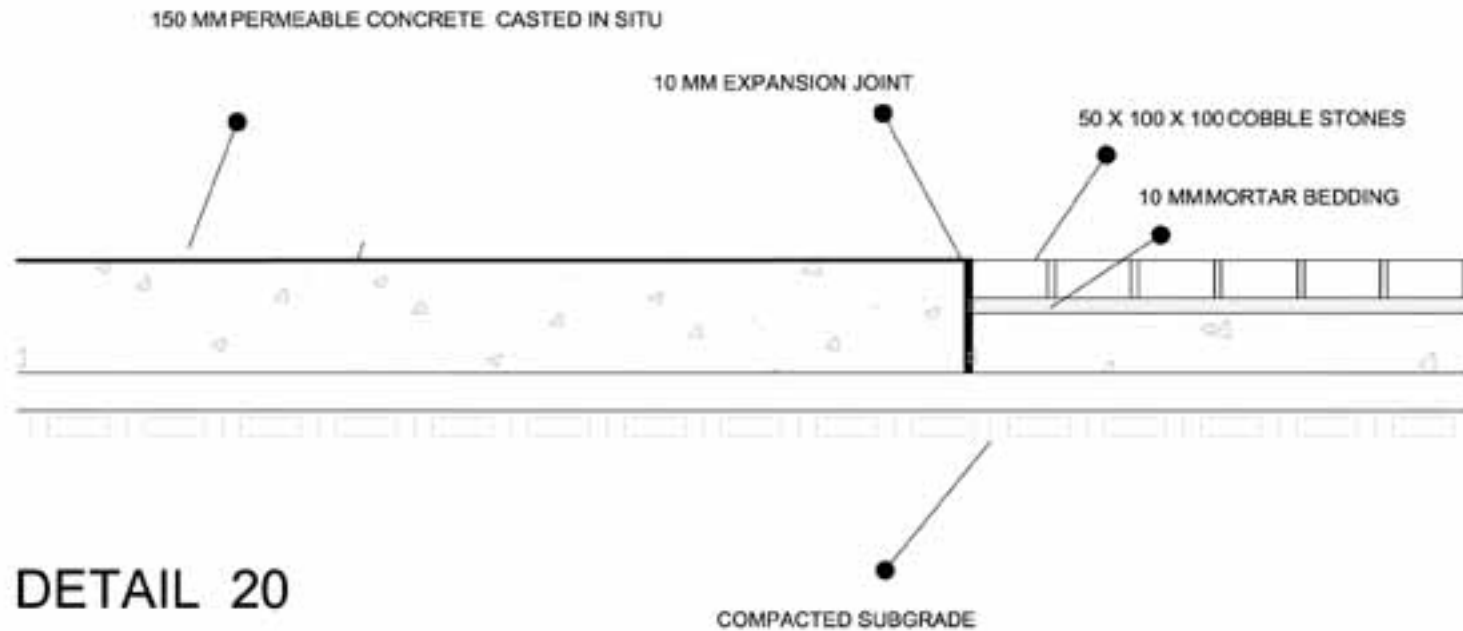

## DETAIL 20

SCALE 1:10