



UNIVERSITEIT VAN PRETORIA
UNIVERSITY OF PRETORIA
YUNIBESITHI YA PRETORIA

T . I . R . F

TUHS INTERACTIONAL RESEARCH FACILITY

Tuks Interactional Research Facility (T.I.R.F)

Growing a university and nations research capacity

W.J.Naude 21012832

Study Leader : R. van Rensburg

Submitted in fulfilment of part of the requirements for the degree Magister in Architecture (Professional) in the faculty of Engineering, Built Environment and Information Technology, University of Pretoria, South Africa

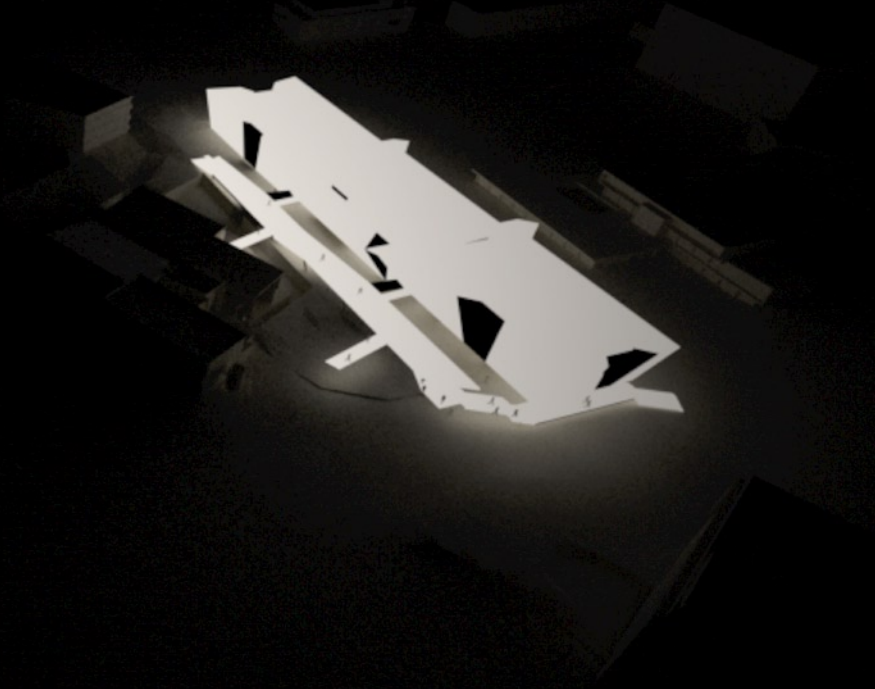

Thank You To:

My wonderful wife Carina, for all her love, patience, support and understanding.

My Parents Johan and Linda, for always being there

My study leader Rudolph van Rensburg

Arthur , Jacque and Edward.

+1 BRIEF

| | |
|---|------------------------|
| 3 | 1.1 Introduction |
| 4 | 1.2 Goal Statement |
| 5 | 1.3 Sub Problems |
| 5 | 1.4 Project Objectives |
| 7 | 1.5 The Client |
| 7 | 1.6 Delimitations |
| 8 | 1.7 Assumptions |

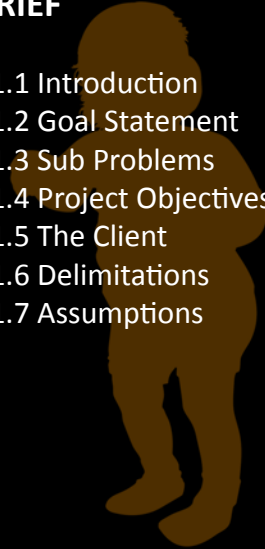

+2 CONTEXT

| | |
|----|---------------------------------|
| 11 | 2.1 Study Area |
| 13 | 2.2 Historic Campus Development |
| 17 | 2.3 Site Selection |
| 21 | 2.4 Site Analysis |
| 31 | 2.5 Research Context |



+3 URBAN DESIGN

| | |
|----|------------------|
| 37 | 3.1 Introduction |
| 38 | 3.2 Vision |
| 40 | 3.3 Theory |
| 43 | 3.4 Analysis |
| 45 | 3.6 Intervention |

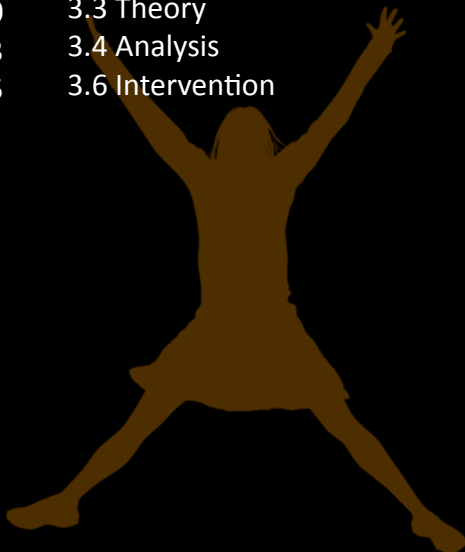

+4 THEORETICAL INVESTIGATION

| | |
|----|---------------------------------|
| 55 | 4.1 Introduction |
| 56 | 4.2 Historic Context |
| 58 | 4.3 Surface in the Public Realm |
| 59 | 4.4 Surface Appearance |
| 59 | 4.5 Exploring Surface |
| 60 | 4.6 Deep Surface |





+5 PRECEDENT STUDIES

- 63 5.1 Laboratory Precedents
- 69 5.2 Surface Precedents



+6 DESIGN INVESTIGATION

- 79 6.1 Introduction
- 81 6.2 Surface
- 95 6.3 Form
- 102 6.4 Intervention



+7 TECHNICAL INVESTIGATION

- 137 7.1 Introduction
- 137 7.2 Structure
- 145 7.3 Planning
- 149 7.4 Climate Control
- 157 7.5 Storm Water
- 158 7.6 Materials
- 162 7.7 Services Design
- 163 7.8 Codes and Standards
- 163 7.9 Sustainable Parameters



+8 APPENDICES

- 167 8.1 Urban Analysis
- 169 8.2 List of Figures
- 175 8.3 References





UNIVERSITEIT VAN PRETORIA
UNIVERSITY OF PRETORIA
YUNIBESITHI YA PRETORIA



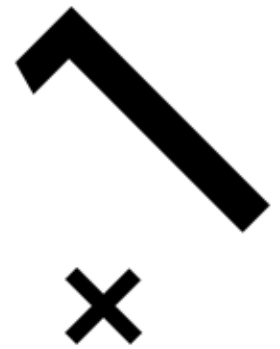

| | | |
|--|---|------------------------|
| | | BRIEF |
| | + | + |
| | | INTRODUCTION 1.1 |
| | | GOAL STATEMENT 1.2 |
| | | SUB PROBLEMS 1.3 |
| | | PROJECT OBJECTIVES 1.4 |
| | | THE CLIENT 1.5 |
| | | DELIMITATION 1.6 |
| | | ASSUMPTIONS 1.7 |



1.1 Introduction

The year 2008 could be the beginning of a defining epoch in the University of Pretoria's history. The university is celebrating its centenary, this year (1908-2008). To build upon the universities standing and history as a leader in the tertiary education and research fields in South Africa it has developed and implemented a strategic development framework, Innovation Generation: Creating the Future, 2007–2011(<http://web.up.ac.za>, 05/03/2008).

The Innovation Generation framework has a number of key objectives to propel its advance towards achieving its main objective:

“Our University is about the future. And how we view the future is directly influenced by the concepts of `quality` and `academic excellence` embedded in our vision. Our University must view itself as the trustee of a quality future. The future is not a predetermined place. We must – as our mission mandates – contribute actively towards shaping that future. This is the essence of our new strategic plan. Its central theme is that of positioning the University of Pretoria as an internationally recognized research university in South Africa.” (<http://web.up.ac.za>, 05/03/2008).

The above statement as taken from the strategic framework clearly shows that the driving core of the “Innovation Generation” is to position the university as an internationally recognized research university. To strengthen this objective, the university aims to develop this field within four guiding principles:

- Research will make a positive contribution to local, national and international needs aligned with the National R&D strategy as well as International trends (<http://web.up.ac.za>, 05/03/2008).;
- Research will be based on the proven capacity that exists within the University and will be built on work of excellent researchers and research leaders (<http://web.up.ac.za>, 05/03/2008).;
- Research themes will not only be defined on

short-term needs, but also be visionary in that they will identify areas of future potential that will require the University to build competencies in order to remain a premier research institution (<http://web.up.ac.za>, 05/03/2008).

- The University research agenda should also take cognisance of unique competencies that exist within the University (<http://web.up.ac.za>, 05/03/2008)..

The Universities Strategic development framework has not been developed in isolation; it has been developed to tie into the greater SA R&D context. “SOUTH AFRICA’S NATIONAL RESEARCH AND DEVELOPMENT STRATEGY” as published in August 2008 by the Government of South Africa, defines the greater context into which the universities development framework fits.

The national R&D strategy identified certain detrimental trends in the national R&D sectors, including; private, governmental and academic that are impeding the growth of the countries R&D sectors.

The most worrying of these issues include:

- The fragmentation of government Science and Technology Sectors. (This is seen as a key weakness, and encompasses all of the National R&D sectors).
- The innovation Chasm that persists in the country; the lack of connection of human capital to the appropriate markets.
- The lack of interest in R&D(S&T) from baseline sectors, school children are not interested in studying sciences.

As stated in the UP's strategic development framework, the university strives to become an internationally recognized academic research institution. Thus to bridge the national and universities contextual barriers in R&D development barriers in order to achieve its central goal, the university requires a research facility that:





1. Unites the fragmented, isolated nature of research on the campus.
2. Implements industry leading methodologies, technological applications and innovative techniques.
3. Builds upon the current capacity of the university, exploiting current fields of expertise as well as providing opportunities for the development of future innovative research areas.
4. Provides for and fosters a climate of networking nationally and internationally with special cognisance being given to “Human Capital” connection, and collaborations. Both with private sector and academic institutions.
5. Generates a Knowledge Base for the Institution.

1.2 Goal Statement

To design a world class research facility that supports the University of Pretoria’s strategic objective of becoming an internationally recognized research institution, a collaborative research environment that promotes networked interaction between researchers, students, the public and private sectors.

A technologically enabled research facility that promotes and facilitates collaborative and innovative, interdisciplinary research, in a building that is flexible and adaptable.

Concurrently the development of an architectural surface that serves to enhance the research environment and all of its complex requirements.

Figure 1.1: Design development section through facility, landscape and circulation

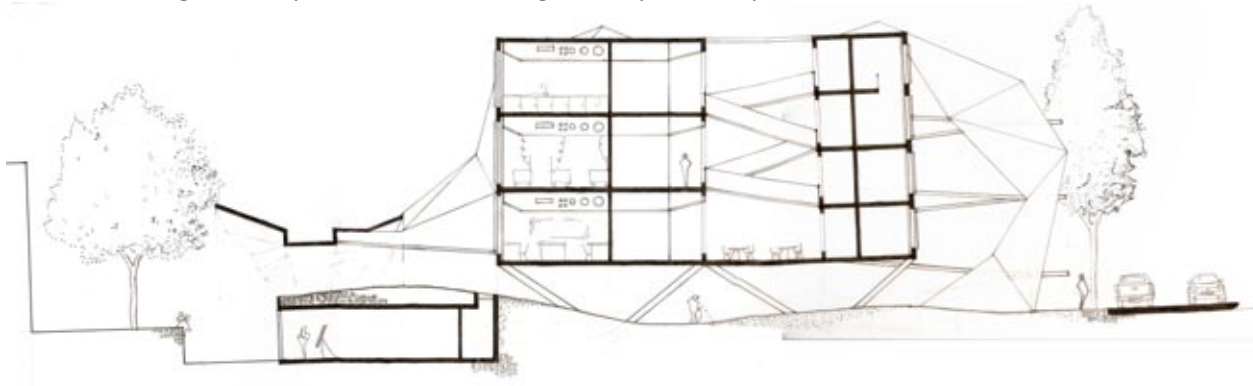

1.3 Sub Problems

1.3.1 How can this building be designed to promote flexible, innovative and collaborative research between students, academics, public and private sectors on a local, national and international level?

1.3.2 How can this building be designed to be flexible and adaptable to fully satisfy the research requirements at the university now and in the future?

1.3.3 Can architectural surface act as; become a representation for “network” that is an inherent part of contemporary architecture. In fact can surface become a point of “network” interaction, connection and communication?

1.3.4 Can architectural surface as a sensory tool be used to define and establish an identity of a building or field of study?

1.3.5 How can this architectural surface be developed to lend its self to an enhanced research environment , with greater sustainable functioning ?

1.4 Project Objectives

A multidisciplinary research facility that promotes interaction and collaborative research, that unites the fragmented nature of research on the University of Pretoria’s main campus and opens possibilities of new explorations by facilitating new inter-faculty collaborations. A research facility that is highly technologically enabled, flexible and adaptable to all research opportunities and requirements of the university both now and in the future. A research building with a sensorial architectural surface, a surface that embodies and gives identity to the research faculties on campus. A building with surfaces that delight the senses and stimulate creativity.

1.4.1 Unification

One of the Universities greatest obstacles in becoming an internationally recognized research institute is that its various research units function as isolated fragments units, which inescapably leads to what is commonly referred to as the “innovation redundancy loop”, this is defined as: “Many organizations are grappling with the problem of repeatedly generating the same ideas, solving the same problems, and creating the same knowledge over and over again, This tends to happen when those doing the knowledge creating, or what we call the pattern creating work are unconnected to the organization’s knowledge base, when the knowledge base is unconnected to the real world outside the organization or when there is no detectable knowledge base in the organization” (VanPatter,2004:11)s.

The proposed new research facility should propagate intelligent research and collaboration. This process should lead to the creation of a Knowledge Base for the university, avoiding the dreaded loop as well as opening up new areas of interest.

“In research, crucial `aha!` moments are often the result of chance meetings between scientists outside the laboratory space, wherever they encounter each other in the course of their movement between the lab, shared equipment rooms, and common areas.

Figure 1.2: Concept sketch of lab, surface interface

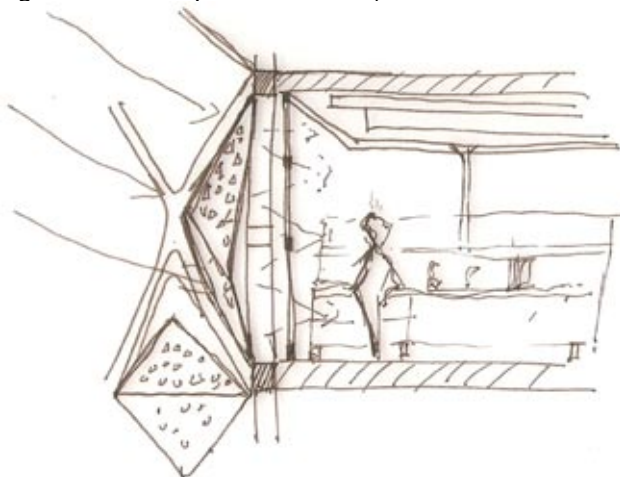



Over the past four decades, laboratory design has seen incremental improvements. In reviewing these developments, one can see that a common theme has begun to emerge: Lab design must facilitate interaction, both within a research group and between research groups. Architects who design research labs know from observation and experience that successful research facilities offer environments that combine rigorous technical sophistication and flexibility with comfort, visual delight, and inspiration—`high tech plus high touch`—thereby setting the stage for constructive interactions”

This objective can be achieved by applying the following strategies:

- Providing an appropriate research facility that caters for team based research,
- That encourages and fosters a climate of interdisciplinary research and collaboration,
- And changes the focus from “Knowledge Production” (Research Volume) to Innovation (Reach Value).

1.4.2 Future LAB Design

The proposed new research facility should be a living Lab that advertises, enables, excites and informs everyone within range.

“A new model of laboratory design is emerging, one that creates lab environments that are responsive to present needs and capable of accommodating future demands. Several key needs are driving the Development of this model: (Watch, 2007)”

- The need to create “*social buildings*” that foster interaction and *team-based research*;
- The need to achieve an *appropriate balance between “open” and “closed” labs*;
- The need for *flexibility* to accommodate change;
- The need to *design for technology* to provide

access to electronic communications systems throughout the building, this has immense implications on lab design;

- The need for *environmental sustainability* (Watch, 2007).

1.4.3 Research Capacity Development

“The modern organization must be competent across the total innovation landscape. This demands an understanding of the different innovation vectors and how the science of innovation intersects with the art of innovation. It is the intersection of these competencies that will provide the appropriate methodological response given a specific need.” (Michael S. Slocum)

By focusing on the universities key strengths as set out in the development framework: “In the South African higher education sector it is distinguished by its internationally recognized strengths in natural and agricultural sciences, engineering and technology, fields...” as well as providing opportunities for new collaboration by integrating the fields of art and design that are traditionally seen as being at variance with R&D/S&T, the universities capacity for developing new and innovative fields of research would be greatly enhanced. This trend can be seen in most of the world’s top research universities.

There is another possibility for investigative research to take place, taking into account the fragmented nature of the universities research units. When the integration of the various research fields take place the exposed fragments (edges) of each of them will come in to contact with raw edges of the others, thus creating the opportunity of interconnection of exposed edges and the discovery of unexpected fields to investigate.

1.5 The Client

The University of Pretoria's Research Support Department is the principle client.

1.5.1 The Client Needs

The university requires additional academic and teaching research facilities for its three foremost research units, including the departments of Natural Sciences, Engineering and Agriculture.

The University has been mandated by government to expand the above fields of study by 50 students per specialty per faculty at undergraduate level. The university thus estimates required research space for an additional 150 post graduate researchers for a period of two years per researcher. The university also requires spaces for interdisciplinary research, and visiting national and international researchers.

1.6 Delimitations

1.6.1. The research facility will be designed to accommodate various types of research; it will thus be a flexible and multi use facility that will not cater for any specific research field or faculty.

1.6.2. The study into architectural surface as a sensory tool will focus on visual perception and the translation of the findings into an appropriate surface for a research facility within the contextual response.

1.6.3. Research facilities are very high energy users because of the energy intensive functions as well as strict environmental regulations for laboratories in terms of air quality and other prerequisites for accurate research. Thus the research in to an energy efficient facility will focus on the study of Daylighting systems, appropriate efficient services and passive climate control.



Figure 1.3: Design development section through central connective atrium

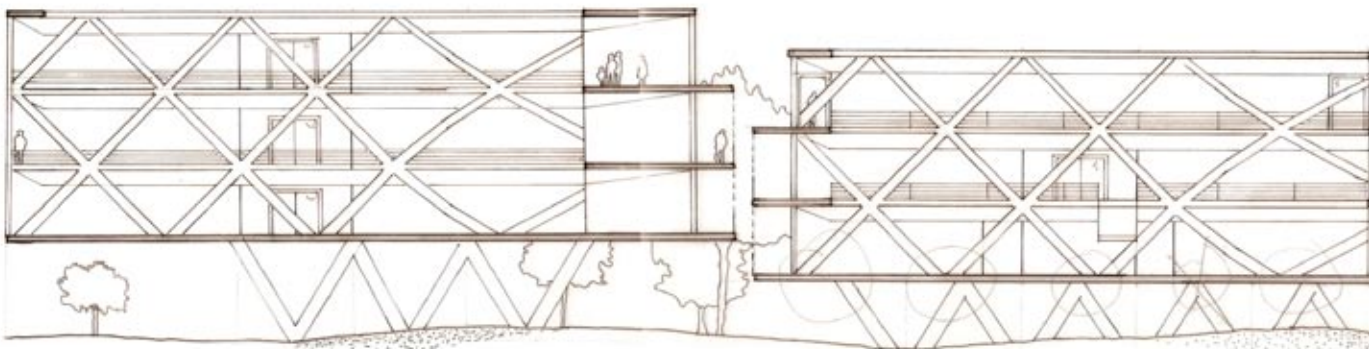

1.7 Assumptions

1.6.1. The University vehicle access and parking is to be Universiteids Weg closed, and a new entrance to the proposed basement parking structure moved to the parking area adjacent to the Nano Electronics building.

1.6.2. The University of Pretoria will (according to the strategic development framework as set out in the campus "Vision") be integrated in to the Hatfield precinct of Tshwane sometime in the foreseeable future.

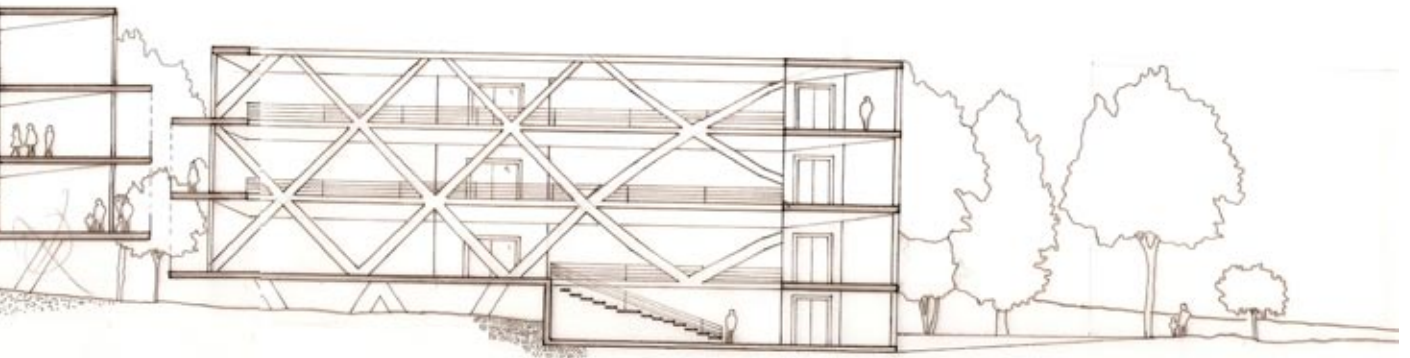



UNIVERSITEIT VAN PRETORIA
UNIVERSITY OF PRETORIA
YUNIBESITHI YA PRETORIA





CONTEXT

+

+

STUDY AREA 2.1

HISTORIC CAMPUS DEVELOPMENT 2.2

SITE SELECTION 2.3

SITE ANALYSIS 2.4

RESEARCH CONTEXT 2.5

2.1 Study Area

The area that this study covers on a local scale includes the Universities properties west of the N1 highway and east of the railway in Hatfield. In a broader context, the universities location and functions within a metropolitan context and with regards to other institutions of note is also studied.

2.1.1 Location

The university is strategically located in relation to both the national N1 and N4 highway routes; these routes provide good access to the campus at national, provincial and local scales.

On a metropolitan scale the university is located approximately 4 kilometres east of the historic core of the city of Tshwane. The University is also located within the important activity nodes of Hatfield/Arcadia and Brooklyn. This positions the University favourably in terms of being located centrally in an 'activity triangle'. The university is located close the

CSIR, Innovation Hub and Human Sciences Council on the metropolitan scale and close to University Of Johannesburg and the Tshwane University of Technology of note on a regional scale. This fortuitous positioning, opens great possibilities to the University in terms of research collaborations and commercial partnerships.

Figure 2.1: Regional scale location diagram

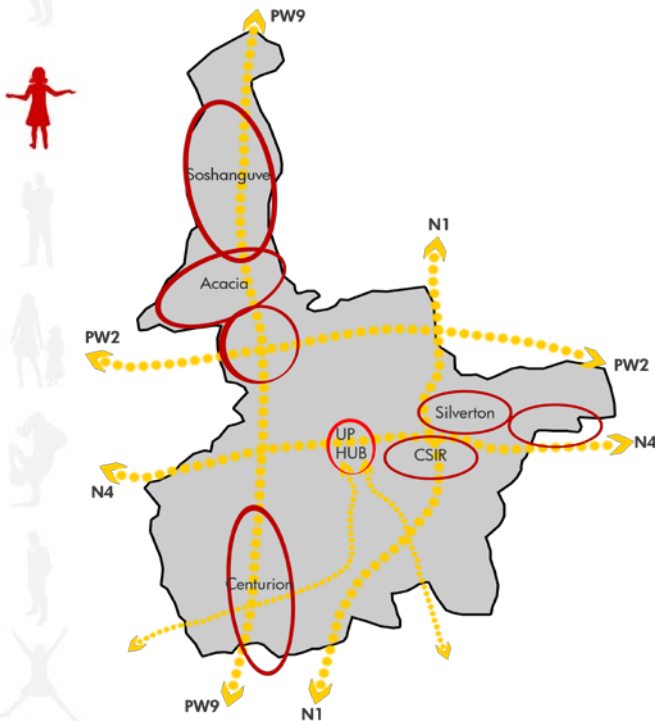

Figure 2.2: Regional scale aerial photograph



Figure 2.3: Metropolitan scale aerial photograph



Figure 2.4: Precinct scale aerial scale photograph



Local (Hatfield)

At precinct scale, the University is located in an area that has undergone tremendous character shift and development in the recent past. Commercial pressure has changed the character of the Hatfield area from a calm student village to a vibrant busy mixed use business zone.

cadia and Sunnyside by the railway line that passes next to the western boundary of the campus. There is thus potential to integrated pedestrians flow from the west to the main campus, making these areas more accessible.

The university is bordered on the northern side by Burnett Street, which is arguably the main activity street of Hatfield, this in its self presents the university with many options in terms of access to the campus and integration with the Hatfield urban fabric.

To the South of the University lies the residential areas of Brooklyn, Menlo Park and Lynnwood, these areas consist mostly of good quality residential stock with big plots and well developed gardens, it is also interspersed with small business mixed in along main routes through the above areas.

To the west of the main campus the university is isolated from the higher density residential areas of Ar-

Figure 2.5: Metropolitan scale location diagram

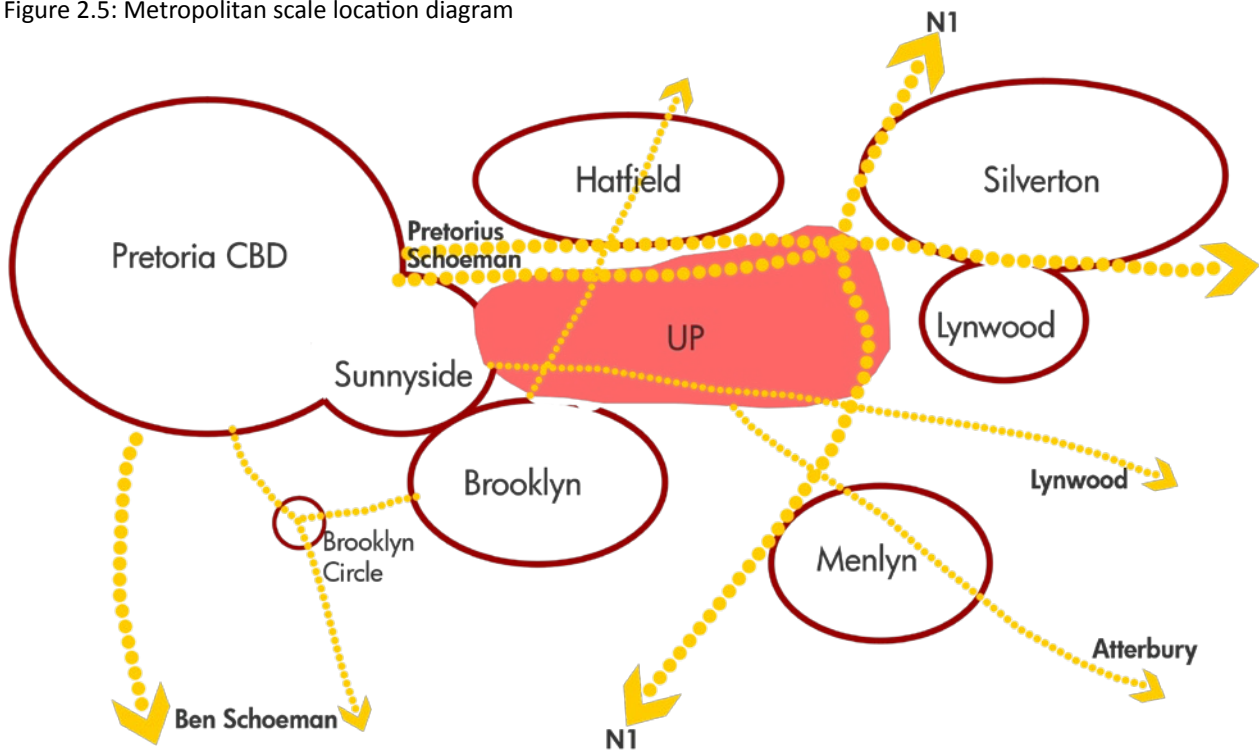



2.2 Historic Campus Development

“From humble beginnings in 1908 when 32 students enrolled for courses at the Pretoria branch of the Transvaal University College, the forerunner of the present University of Pretoria, the institution has grown into a leader in tertiary education. Today more than 50 000 students study in the nine faculties and a business school for the 371 undergraduate and 1 522 postgraduate study programmes on offer.” (<http://web.up.ac.za/default.asp?ipkCategoryID=5035>, 26/09/08)

2.2.1 Building Typologies

The campus building structure is defined by a number of building typologies that represent most buildings on the campus. These building typologies include: (G.P Greef and associates, 2000: 18-19)

Courtyard Buildings

This building type occurs on the older western part of the campus and is between two to three stories high and positioned around a central courtyard and is designed for natural lighting and ventilation. The building uses vary from laboratories, offices and lecture halls. (G.P Greef and associates, 2000: 18-19)

Lecture Halls

These building types occur dispersed across the campus and are typically two to three stories high, they are usually designed with a single function in mind. The buildings are mostly withdrawn in relation to their site positioning, except for their entrances. (G.P Greef and associates, 2000: 18-19)

Office Blocks

Office blocks appear on campus as three to six story high rectangular buildings. They include the academic functions of small lecture halls, academic supportive and administrative. (G.P Greef and associates,

2000: 18-19)

Tower Blocks

This building typology is very similar in terms of function to office blocks, there were however only three of them built on the campus, and this is due to the inflexible nature of this building typology. (G.P Greef and associates, 2000: 18-19)

Figure 2.6: 1921 Campus Development

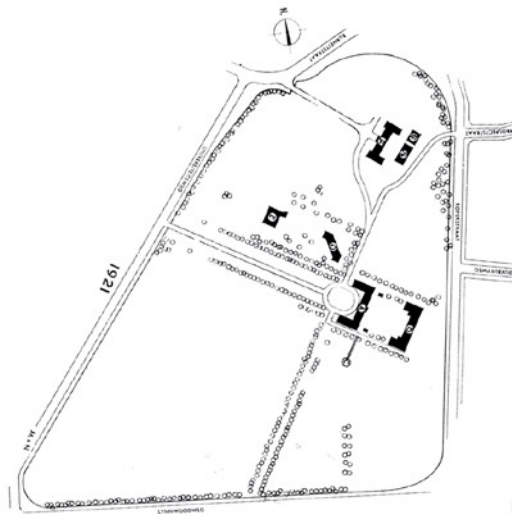
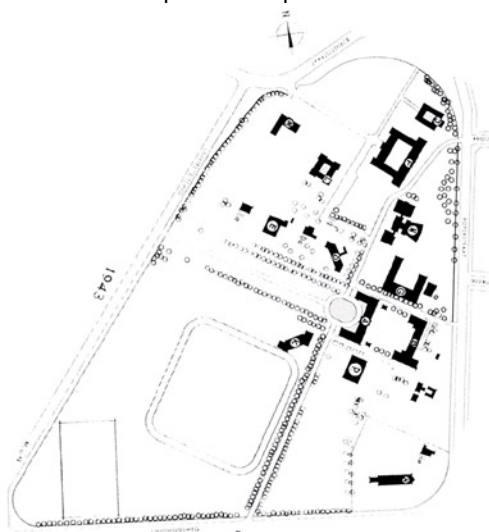

Figure 2.7: 1943 Campus Development





UNIVERSITEIT VAN PRETORIA
GEBOU — 1960



Workshops and Labs

Are mostly positioned on the periphery of the universities boundaries, they are typically between two to four stories and have great potential for refurbishment due to the robust nature of their structures and well dispersed services.

Special Structures

These include the Library, cafeteria, study areas, Aula that are required for the effective functioning of the campus. Due to their specific functions, they require specific structures that are costly to maintain and change.

Figure 2.8: 1960 Campus Development

UNIVERSITEIT VAN PRETORIA
GEBOU — 1970

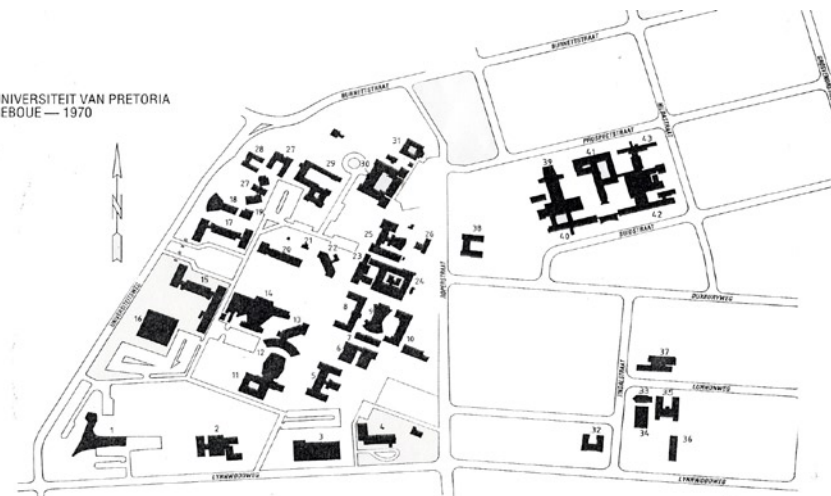
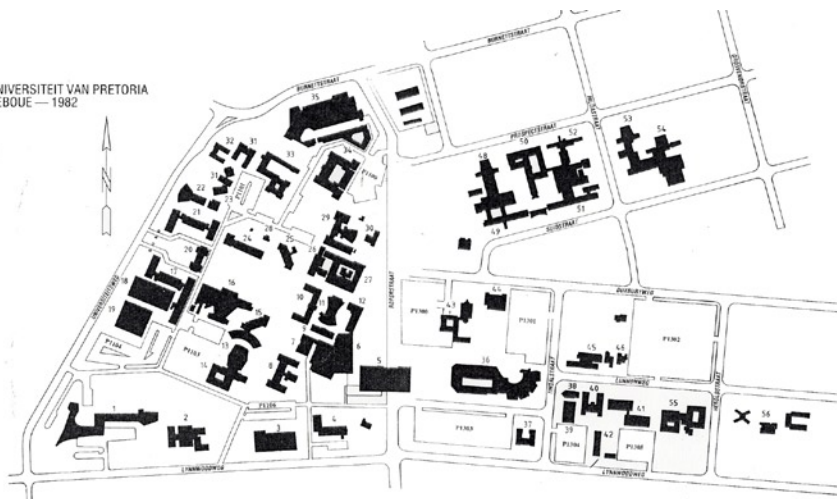

Figure 2.9: 1970 Campus Development

Figure 2.10: 1982 Campus Development

UNIVERSITEIT VAN PRETORIA
GEBOU — 1982



2.2.2 Open Space Structure

The University of Pretoria's main campus is characterised by a good open space structure that is pedestrian oriented. The open space structure on campus can be divided into three categories, Soft Open space, and Hard Open Spaces, axis and circulation spaces. (G.P Greef and associates, 2000: 21)

Soft Open Spaces

Soft open spaces on the campus can be defined in three purposeful categories; Functional Social Spaces, Educational Spaces and Landscape buffer zones.

Functional social open spaces (Figure 2.12) refer to large scale open spaces which contribute greatly to the structure and functioning of the campus. These spaces have a strong social character and function as the heart of the campus as well orientation spaces. The major spaces identified as such include the lawns in front of the Aula, Merenski Library and the student centre.

Educational soft open spaces (Figure 2.11) also occur on the campus; they are located on the western border of the campus and occur as spaces between buildings with an intimate scale. These spaces are the botanical gardens surrounding the botany faculty.

Buffer Landscape zones (Figure 2.13) occur all over the campus and are space that have no specific function, however they serve as buffer zones between buildings, roads and structures and form part of the greater campus open space structure.

Hard Open Spaces

The hard open space structure (Figure 2.14) of the campus is a complex network of pedestrian activity spaces, circulation routes, parking areas and service areas.

2.2.3 Axis and Circulation:

The campus has traditionally evolved around certain visual and circulation axis. These historic axis play an important role in the design and development of the Campus, as well as the functioning of it. G.P Greef and associates, 2000: 22)

The axis provides structure and form to the Campus and integrates various components with each other. Essentially it forms the movement framework that connects all Campus facilities and makes building and facilities accessible.

The main axis identified on campus include; The North-South axis from the Lynnwood pedestrian entrance to the Burnett street pedestrian entrance, The West-East axis from the Universityds weg entrance

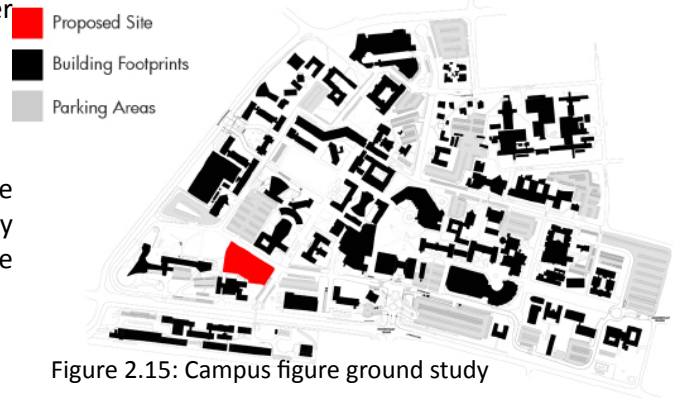

Figure 2.15: Campus figure ground study

past the lawns in front of the Aula to the student centre and the East-West axis from road entrance to the Library

2.2.4 Constrains and Problems:

Figure 2.16: Campus soft open space structure



Figure 2.17: Campus building use study



Figure 2.18: Campus possible development sites



The campus has a number of historic problems that can be clearly identified and contribute to the overall Campus spatial structure problems, they are:

1.The large amount of traffic routes through and around the campus, which contribute to a pedestrian environment that is dangerous and uninviting.

2.The perimeter security fencing creates an environment that has restricted access and uncomfortable movement patterns.

3.Access to the main Campus has poorly defined gateways, which contribute to a negative pedestrian environment and campus image.

4.Historic movement axis are terminated inappropriately and are poorly defined

5.Parking facilities on campus are placed insensitively to the campus landscape and inefficiently use valuable campus land.

6.There are many under utilised spaces on the Campus that require higher development densities to reach their full potential.

7.The traditional Hart of the Campus has shifted from the Lawn in front of the Aula to the Lawn in front of the Student Centre has lead to this space losing

Figure 2.19: Campus circulation and axis study



2.3 Site Selection

Choosing a site for the development of a new research facility for the University of Pretoria was a difficult task due to the numerous performance criteria the site had to adhere to. The performance criteria were implemented to choose and develop a site that would be the most appropriate for the chosen function of the facility and its intended urban effect.

2.3.1 Performance criteria

A. Accessibility & Legibility - The site has to be located in a area that is easily accessible by pedestrians and vehicles, preferably on main axis. Further the site has to be located in a area that has good access to public transport facilities. The site also has to be located where it can be come a recognised icon on the campus, to act as the flagship unit for research on the University's campus, to give research prominence and identity

B. Size - A rather big site is required in campus terms to accommodate a facility that would require a large footprint area to function properly.

C. Research Location - As the facility is being developed to develop all research on campus it focuses on the top three research field at the university, agriculture, engineering and natural sciences. The optimal site solution would be located centrally between these 3 research facilities.

Figure 2.20: Site location diagram



D. Urban Location - As part of the project development an urban design strategy will be developed to facilitate the creation of a research precinct on the campus. Further to this the site has to be located in an area that has surrounding potential for further research developments. Part of the urban strategy will mandate that the site be located as close to the current arts precinct as established on campus to facilitate interdisciplinary research to take place.

Figure 2.21: Site and Precinct location

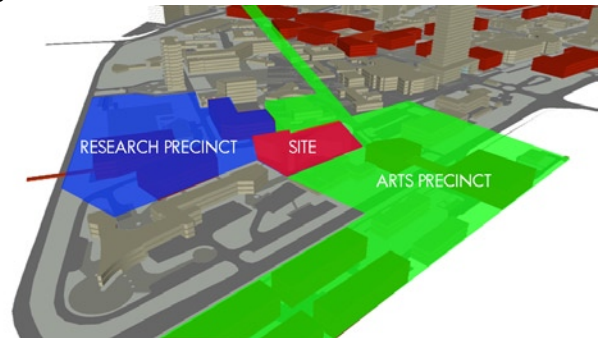

E. Densification - The selection of a site that is currently used for low density development or is under developed is of critical importance. It is also of critical importance to avoid greenfield sites. This is due to the diminishing scale of green open space, and to preserve the communit(village) atmosphere of the campus.

2.3.2 Chosen Site

The site that is deemed most appropriate and satisfies the performance criteria best is the current parking area located at the northern boundary of the visual arts department and southern boundary of the music department.

With reference to the performance criteria the site was chosen for the following reasons.

A. Accessibility & Legibility - The campus internal ring road and Tukkie laan pedestrian entrance form the eastern boundary to the site, these are to main cir-

culuation axis on the campus. It is also a site with great visibility from the main Roper street entrance to the campus and is visible from various vantage points off campus.

B. Size - The site is deemed to be big enough to facilitate any developmental need that the research facility would require.

Figure 2.22: Site surround development potential



C. Research Location - The site is almost triangulated with the top three research facilities and fields on the campus.

D. Urban Location - Open space is for future development is abundant around the site, the open space available consists of buffer green spaces and low intensity parking areas. Secondly the site is sandwiched between two of the prominent facilities in the art precinct, thus providing a vital precinct connection.

Figure 2.23: Current site use aerial photograph



A number of possible sites were evaluated before the final site selection was made. Figure * illustrates the four possible sites.

No1. is a low density parking lot located next to the Nano-Electronics facility. Its location was good, however its shape and size were considered unfavourable.

Figure 2.24: Site surround development potential



No2. As with site 1, site and all the other sites considered are low density parking areas. Site number two was not considered for the development due to the fact that it was already selected for another thesis project.

No.3 Is the final project site.

No.4 Was investigated however it did not meet any of the performance criteria, hence it was also not deemed suitable.



Figure 2.25: Public transport surrounding campus

2.4 Site Analysis

2.4.1 Geographical Data

Pretoria is situated at 1370m above sea level at 25°45`S, 28°12`E. (Napier, A.2000: 9.8)

Macro Climate

Pretoria is located in the Northern Steppe Climatic zone. (Napier, A.2000: 9.8)

Meso Climate

Pretoria has a diurnal temperature range in the summer from 28.8° to 12,2°C in the summer and 25,7° to 2,6°C in the winter. Extreme heat in the summer and frost in the winter is not uncommon. The average monthly humidity is 59%. (Napier, A.2000: 9.8)

Rainfall

The mean annual rainfall of Pretoria is 700mm of which 88% falls in the summer months. (Napier, A.2000: 9.8)

Wind

In the summer 41% of the days receive light breezes to no wind, this amount increases to 60% during the winter. Summer wind direction is east-north-east, winter wind directions are north-west and north east. (Napier, A.2000: 9.8)

Sun Angles

Solar incidence in Pretoria is high with a maximum of 80% sunshine in the summer and a minimum of 67% in the winter. The percentages translate into solar radiation energy of 8W/hr/m²/day in the summer and 4.5W/hr/m²/day in winter.

Summer Solstice is on 21 March and 23 September at 64.24°, winter solstice is on 22 June at 40.73°. (Napier, A.2000: 9.8)

Geology

The area surrounding the site consists of three distinct layers:

1. 0-5.5m Locally eroded andesitic lava containing agglomerate.
2. 5.5-6.1m Blue-green Andesitic lava enmeshed with thermally altered sediments
3. 6.1-120m Solid Andesitic lava, containing agglomerate.

The water table is located at approximately 18m deep during summer months. The soil has high bearing capacity with negligible swelling capacity.

All of the previously listed geographical and climate data play an important roll in the design and technical development of the facility. In chapters five and six the design response to these parameters will be investigated.

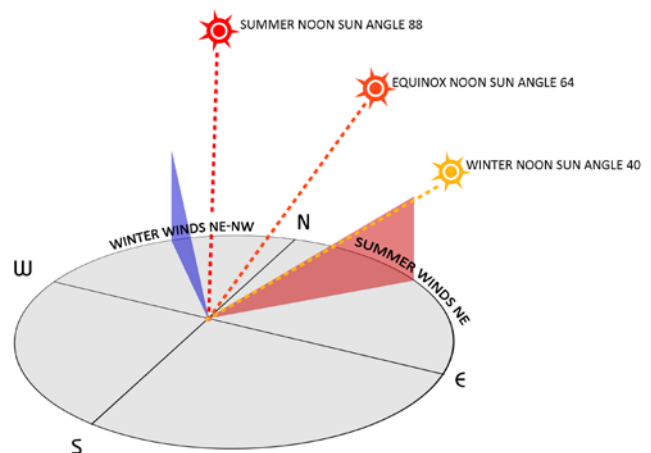

Figure 2.26: Site climate analysis diagram



Figure 2.27: Panorama of Southern neighbour (Visual Arts)



Figure 2.28: Panorama of eastern neighbour (Boukunde)



Figure 2.29: Panorama of Northern neighbour (Music Department)

2.4.2 Existing Site Features

The chosen site is located on one of the many Parking lots that are strewn across the University grounds; it is a low density usage for such a valuable piece of land. The Site is located at the junctions of the inner ring road transport system and the Lynwood road pedestrian entrance, thus it is a prominent site. The site is surrounded by trees and vegetation making it a sensitive site to work on. The site is bordered on its northern side by Fever trees, the ring road and the Music Department. Boukunde and the Tukkies Lane pedestrian axis dominate the eastern border, on the southern side it is linked directly with the Visual Arts Building and the western border is occupied by a buffer green open space and the main administration building.



Figure 2.31: Panorama of Fever tree lane

2.4.3 Neighbouring Features

The four buildings that border the site are all important buildings in their own right both in terms of architectural quality and in terms of campus function. Boukunde and the Administration building are iconic buildings with the Visual Arts and Music department buildings being more understated. These four buildings accommodate a range of functions from academic, performance to administration.

Boukunde, Visual Arts and the Musaeon are all part of the greater arts faculty and form the cornerstone of the arts precinct on campus.

Figure 2.32: Diagram showing neighbouring site features

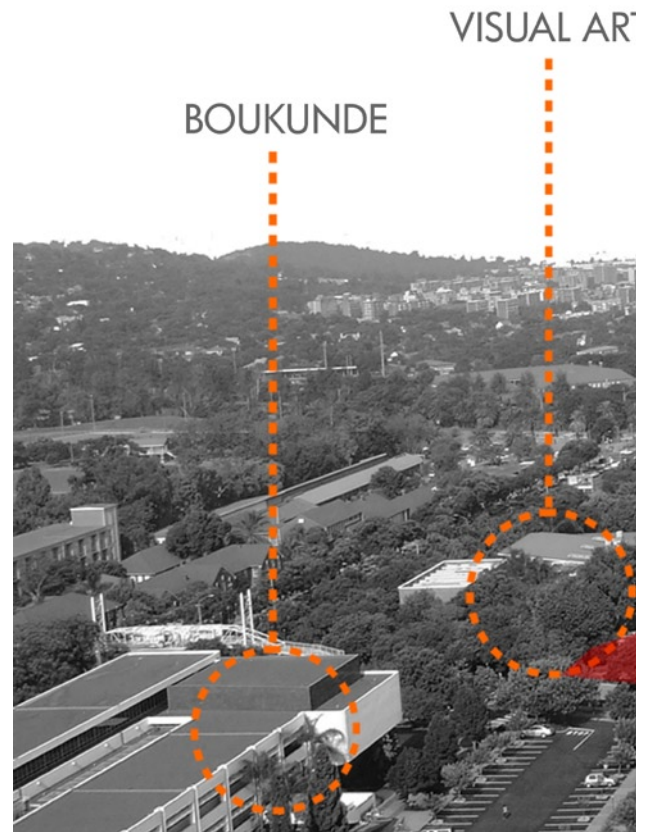

- Proposed Site
- Building Footprints
- Parking Areas

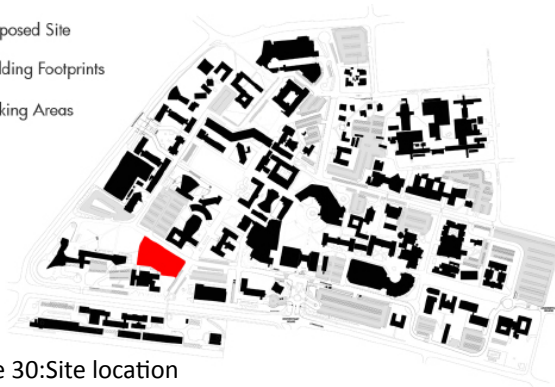

Figure 30: Site location

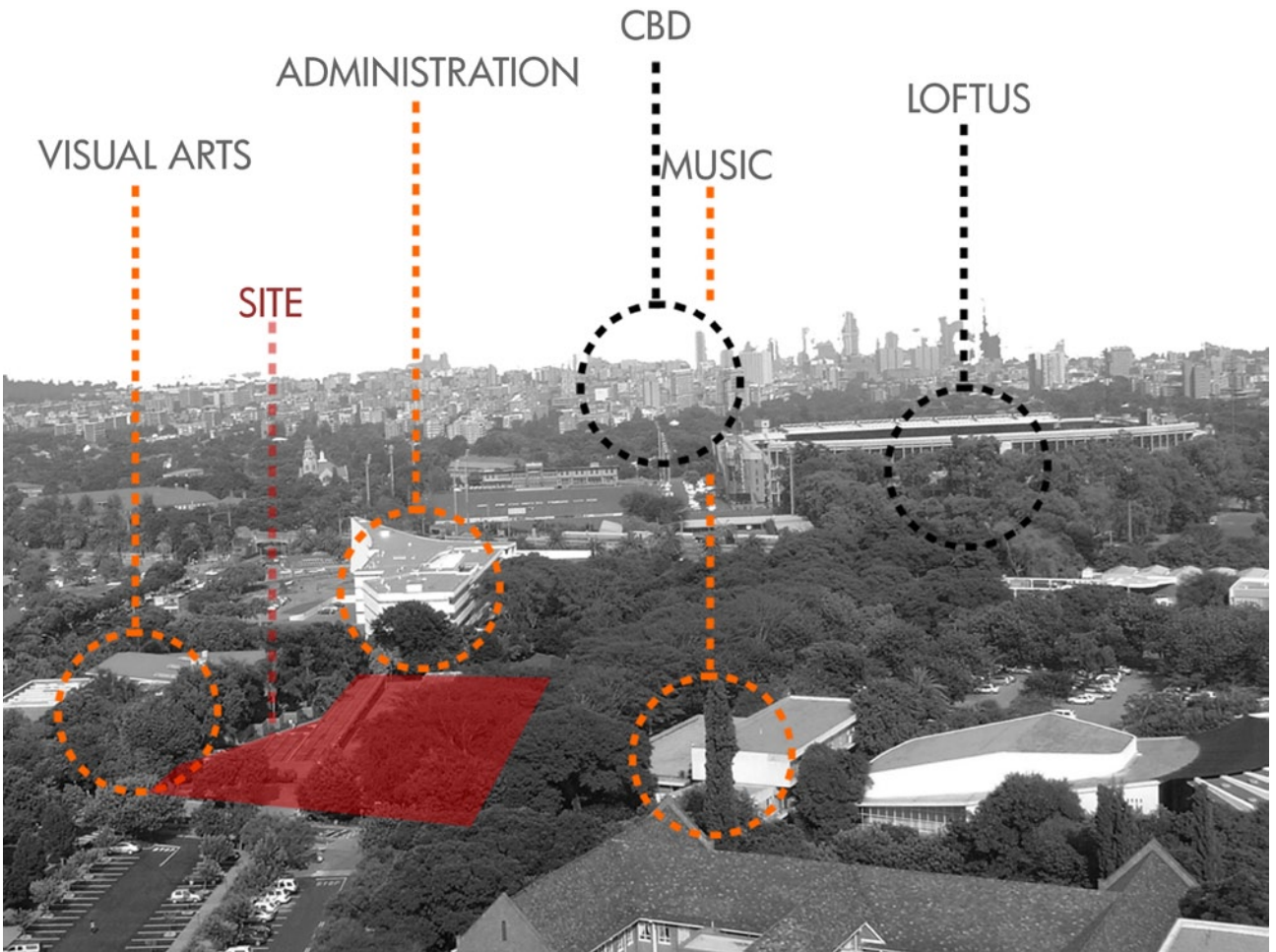



Figure 2.33: Photograph of Boukunde's Western facade



Figure 2.35: Boukunde location diagram

Boukunde

Architect

The original building was design by the resident lecturers of the time.

Date

The building was opened in 1960

Style

The building was designed in a formalist modern style

Importance

The building is representative of period architecture on campus and represents the heart of architecture and construction on campus. It is a striking iconic fair faced concrete building.

Figure 2.34: Photograph of Boukunde's Northern facade





Figure 2.36: Visual arts location diagram

Visual Arts

Architect

Meiring and Naude, Burg & Lodge and Burg

Date

8 October 1948

Style

The building was designed in very reserved modernist style as result of the materials restrictions enforced during WWII

Importance

The building was originally design as teachers life sciences training facility, later it was adapted to house the Visual Arts department, which to this day functions as the Anchor of the arts on campus.



Figure 2.37: Photograph of Visual Arts main entrance

Figure 2.38: Photograph of Visual Arts` NE corner





Figure 2.39: Photograph of Administration Northern fa-



Figure 2.41: Administration location diagram

Administration

Architect

Brian Sandrock

Date

The building was opened in 1969

Style

The building was designed in the `new Brutalist Style`

Importance

The building is an iconic part of the campus history, it is closely associated with the University and lends identity to the campus, it also forms part of the Brian Sandrock Brutalist stock on the campus grounds



Figure 2.40: Aerial photograph of the Administration





Figure 2.42: Musaion location diagram

Musaion

Architect
Brian Sandrock

Date
1964

Style

The building was designed in very reserved modernist style as result of the materials restrictions enforced during WWII

Importance

The building forms part of the Brian Sandrock Brutalist stock on the campus grounds, it was and is also the first formal home for the Music department on the campus and has served the University and its students well for education and performance purposes.



Figure 2.43: Photograph of Musaion main entrance

Figure 2.44: Photograph of Musaion Western facade



2.4.4 Views

At ground floor level the site is bisected by numerous views of neighbouring sites and axis. These will become important formal determining factors as can be seen in the design development chapter. There are two major axial views bordering the site on its eastern and northern borders with the pedestrian dominated Tukkies Lane and the vehicle dominated ring road.

Moving up two a second story level, there are fine views to appreciate to the south and west, views that encompass parts of the residential areas of Brooklyn, Waterkloof and the CBD of Tswane.

2.4.5 Orientation

The site is irregularly shaped and its predominant edge runs roughly east to west; it has good northern sun exposure in the winter and also problematic western sun exposure in the summer.

2.4.6 Circulation

The site is bordered on its northern side by the main campus ring road transport system and on its eastern side by the main Pedestrian entrance from Lynwood road which connects to Tukkies Lane a major pedestrian artery on campus. These two factors combine to make the site very well placed and under utilized for its strategic location. The site also acts as a pedestrian gateway from the eastern and northern side to and from the administration building as well as to and from the music and engineering departments. However these two routes are informal and unstructured, they result in the termination of three pedestrian routes when they meet the borders of the site, and require urgent attention.

2.4.7 Site Constraints and Opportunities

The site as it is currently found has a number of constraints and opportunities. The following is a summary of the major influencing factors.

The site's main strengths include its accessibility and location in relation to main pedestrian and vehicular circulation routes, its location at the heart of the art precinct, its landscaping and natural setting and the possible views that are accessible from the site.

The site's main perceived weaknesses include its exposure to westerly sun in the summer, the isolation and noise generated by the internal campus ring road, possible lack of adequate natural ventilation in the summer and winter, and its undefined edges, low density and irregular shape.

Possible constraints on the site that might influence any development include, the Visual Arts Building that requires Northern winter sun that cannot be blocked, the pedestrian routes that have been established across the site and the amount of vegetation and trees around the site.

Figure 2.45: Site access and movement analysis diagram

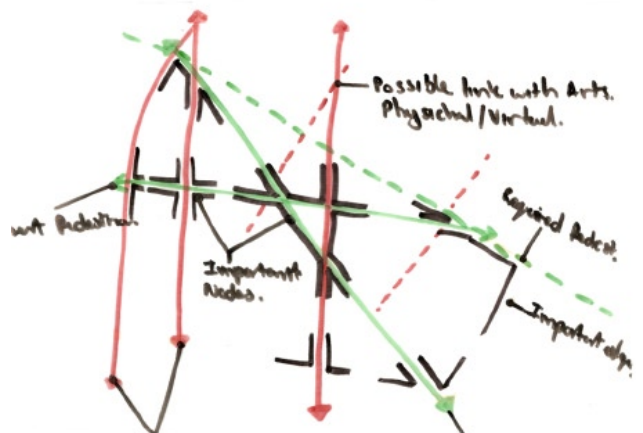



Figure 2.46: Site views diagram

Figure 2.47: Panorama of main Tukkies laan and ring road intersection



2.5 Research Context

“Being an internationally recognised South African teaching and research intensive university is central to the University of Pretoria’s new strategic plan.

Since its humble beginnings in 1908, the University has gone a long way to achieving this goal and is currently considered to be one of the leading institutions of higher education in the country.” (<http://web.up.ac.za/default.asp?ipkCategoryID=5035,26/09/2008>)

As stated on the research department web site, the University of Pretoria has made great advances towards achieving its goals. The following figures published in 2007 show the current standing of the university in the national and international context.

The University of Pretoria currently ranked the 4th best research university in South Africa, it is out ranked by the Universities of Stellenbosch, Rhodes and Cape Town. (http://www.webometrics.info/rank_by_country.asp?country=za,07/03/2008). Internationally the University of Pretoria is ranked as

no 686 of 1000 ranked world universities, the highest ranked occur in the Americas (1-8) Europe (10, 23,25) Asia (20,22,76) Australia (79). (Available: http://www.webometrics.info/top1000_r&d.asp?offset=400,07/03/2008)

It is evident from these figures published in 2008, that the University of Pretoria requires drastic improvements to become an internationally recognised research university. Contemporary performance criteria are of vital importance to achieve this goal, these criteria will be discussed further in the Technical development chapter.



Figure 2.48: National Research context diagram

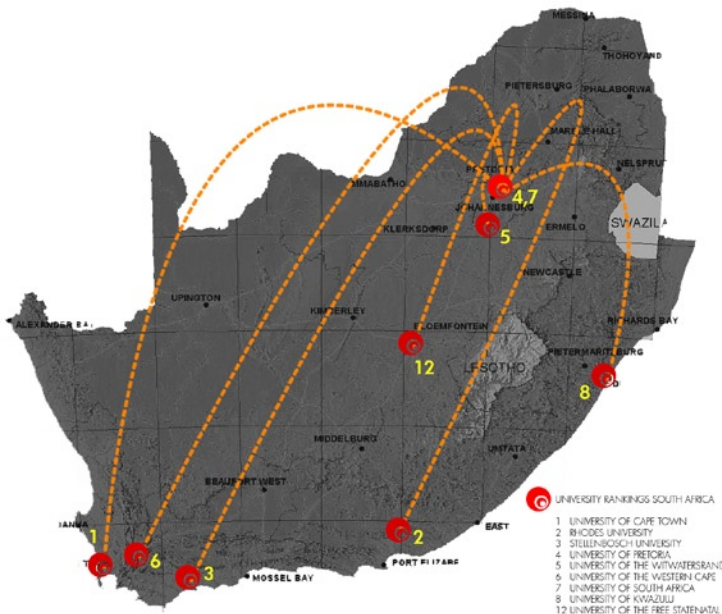

Figure 2.49: Regional Research context diagram

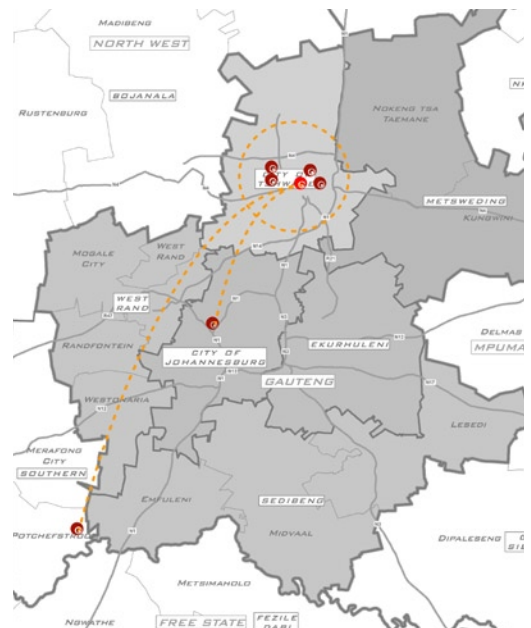
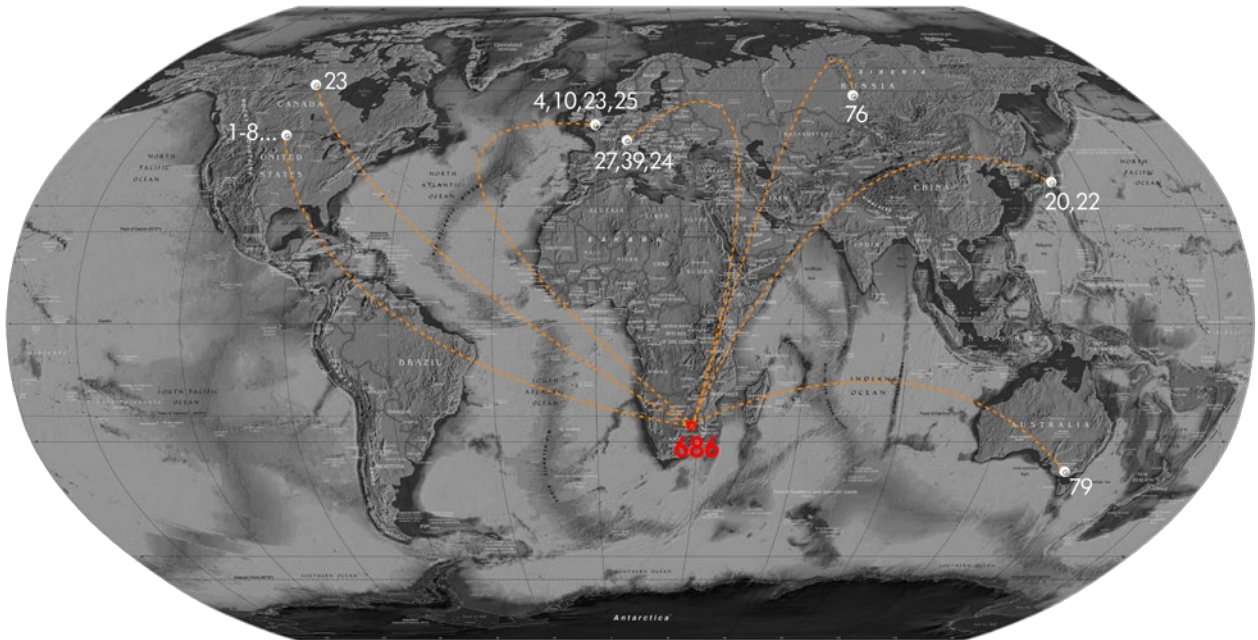

Figure 2.50: Internaltional Research context diagram



2.5.1 TUKS Research Environment

“In the post-war building boom of the 1950s and 1960s, American colleges, universities, and corporations built tens of millions of square feet of laboratory space for the sciences. Many of those buildings have proven inflexible in design, preventing their easy adaptation to evolving research needs and the accompanying expansion of building systems.” (Goldstein. R. N.2006, 243)

As stated above most of the research facilities on the University of Pretoria’s campus are old, inflexible and outdated. As can be seen in images 46-50 the research facilities are bound by the same constraints as most of the research stock of the same era.

Older buildings are designed on inflexible principles, the common problems among labs studied include:

1. Too Narrow (Floor Plan depth)
 2. Floor to ceiling height insufficient
 3. Structural bays to small
 4. To little space for services and utility shafts
 5. Not design for interaction (isolation)
- (Goldstein. R. N.2006, 243)



FABI (Forestry, Agriculture and Bio Industries) is the newest research facility on the campus, as shown in figure 48. Even this new research facility avoids away from the contemporary performance criteria for the development of successful slabs. It is an introverted building, isolating its self completely from the campus community, it also make no attempt to communicate or facilitate interaction. It also does not allow any room for future expansion and development due to its site use.

“If one accepts the premise that improved collaboration between researchers will more effectively lead to scientific breakthroughs and ultimately benefit humankind, then a logical implication would be that lab design should be optimised to enhance such collaboration.” (Goldstein. R. N.2006, 246)

The above quote reinforces the concepts to be employed in the development of a new research facility on campus, not to replace existing stock, rather to collaborate and support. To provide a new research base from where the university can launch its aspirations of becoming an internationally recognised research facility.

Figure 2.51: Agriculture research storage and wash area



Figure 2.52: Natural sciences research lab



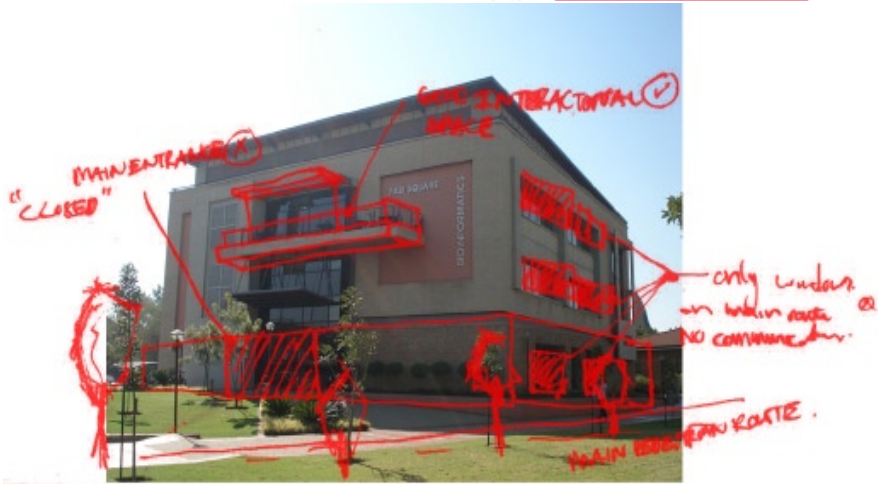

Figure 2.53: New Fabi research Lab

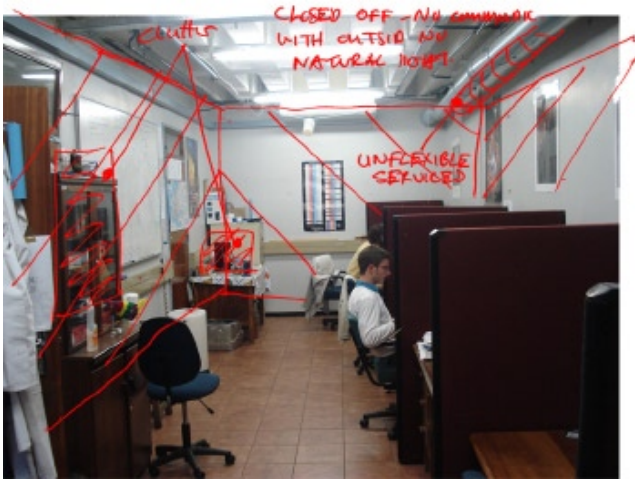

Figure 2.54: Engineering research lab write up area

Figure 2.55: Engineering research lab





UNIVERSITEIT VAN PRETORIA
UNIVERSITY OF PRETORIA
YUNIBESITHI YA PRETORIA



WALDRAND



UNIVERSITEIT VAN PRETORIA
UNIVERSITY OF PRETORIA
YUNIBESITHI YA PRETORIA



URBAN DESIGN

+

+

INTRODUCTION 3.1

VISION 3.2

THEORY 3.3

ANALYSIS 3.4

INTERVENTIONS 3.5

3.1 Urban Design

“Urban design is the process of shaping the physical setting for life in cities, towns and villages. It is the art of making places. It involves the design of buildings, groups of buildings, spaces and landscapes, and establishing the processes that make successful development possible (http://www.udg.org.uk/?document_id=468 ,29/09/2008).”

“ The attempt to give form, in terms of both beauty and function, to entire areas or to whole cities. The focus is on the massing and organization of buildings and on the spaces between them, rather than on the design of individual structures (<http://students.ou.edu/H/Antonia.G.Hoberecht-1/IntroToUrbanDesign.html> ,29/09/2008).”

The University of Pretoria lies within the greater Tshwane Metropolitan council, at a smaller scale it is part of the Hatfield local precinct. However the University functions as an isolated entity due to its enclosed nature. The study of urban design theories and performance criteria that are to be implemented in conjunction with the `Campus Development Vision` to create a better campus environment for all. This study will focus on the urban analysis and design at a campus scale and then again within a smaller precinct level within the campus structure. Urban design takes place at multiple levels and scales from; Identifying large scale ordering structures as well as proposing new elements that define the urban fabric, in which smaller scale place making and public space design takes place.



3.2 Campus Urban Design

VISION STATEMENT

“TRANSFORMING THE UNIVERSITY OF PRETORIA FROM AN ISOLATED FRAGMENTED KNOWLEDGE PRODUCTION INSTITUTION, TO A **UNIVERSITY CITY**, A CITY OF **INNOVATION**.”

Transforming the University and the Hatfield precinct into a **UNIVERSITY CITY**, an integrated networked city of innovation and social cohesion, where public sector interfaces with the private sector, interfaces with the academic sector. Removing physical, social and virtual boundaries that are constraining both the University’s and Hatfield precincts growth, creating a social amalgam that celebrates and empowers the uniqueness, vitality, potential and culture of South Africa’s premiere Academic community.

The transformation is a two phased proposal with a single vision as driving force; it consists of the transformation of the University into a “University City” and concurrently the transformation of Hatfield into a diverse, vibrant and regenerative social hub that enables the conception of a University City.

University Village

The University of the Future is the University of Pretoria is a city of knowledge. The UP as a village is the first step in achieving the vision of the university as a city. A village that is the “brain” of the “University City” a village where the urban fabric is design at a human scale, where the buildings become nodes of social and academic interaction, and the exterior spaces act as outdoor rooms for academic discourse and social play; A village that has its own tangible and definable character, identity and vitality, a village that has clarity of circulation that is dominated by pedestrians; A village that is designed for the night time, which has a vibrant and cultural night life. The university village will function as community, working as an inter-related whole a symbiotic relationship of allied units. The transformation of the university into a village will prepare it to continue functioning as a holistic entity when integrated with the “University City” precinct.

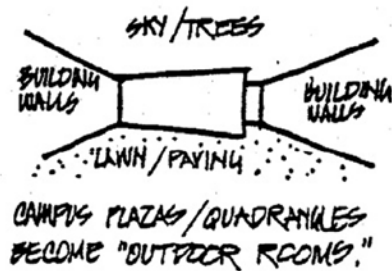

Figure 3.1: Campus outdoor rooms



Figure 3.2: Campus architectural character

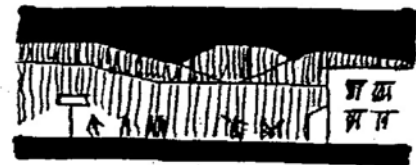
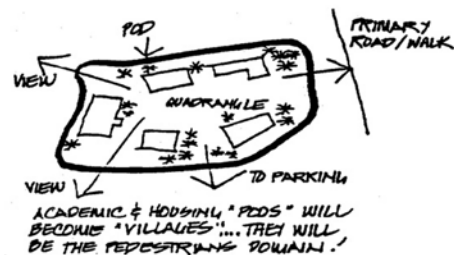

Figure 3.3: Nighttime campus lighting

Figure 3.4: Campus as a village



Social Hub

Hatfield precinct is to be developed to create destination place. A place of continual social, cultural and civic regeneration; a place that defines its self as the vibrant, multifunctional “body” of the “University City”, Hatfield is to be the gateway of the “University City” precinct. Hatfield’s continual transformation will be driven by the creation of interdependent nodes including, transport, mixed use, culture, commerce and political, allowing a dynamic interface for social expression. Hatfield must become a place for the people, for businessmen, academics, students, professionals, politicians, workers; Hatfield must be a place for all.

The University City

To achieve the University of Pretoria’s strategic objective of becoming a world class research institute, the Hatfield “social hub” and the “university village” need to merge from two vibrant successful independent isolated entities to a coherent spatially integrated community, without boundaries and borders. The future is now and that brings with it the world of Virtual spaces, virtual lectures, virtual libraries and virtual paths, thus there is an intense need to allow the community to enter upon campus grounds to fully utilise all facilities that will become obsolete in the virtual age. The unification of these two distinct identities must not allow the dissolution of either’s unique identity but rather reinforce each other key strengths and opportunities to allow a true city of knowledge to be born, a “UNIVERSITY CITY”.

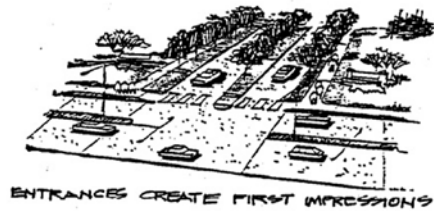

Figure 3.5: Campus main entrances



Figure 3.6: Campus must be a safe environment

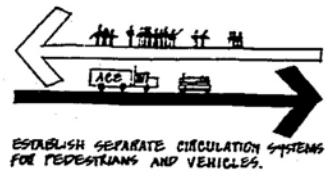

Figure 3.7: Campus circulation to separate cars and pedestrians



3.3 Theory and Performance Criteria

Developing an urban design strategy for the University of Pretoria required the use of various urban design theories and performance criteria. The theoretical approach that was used is that of Kevin Lynch, his 5 elements of urban design. The theory centers on the image of the city and creating understandable and readable environments. This theory was used and applied at the larger precinct scale of the university to identify the elements that define the larger urban fabric.

Kevin Lynch (Lynch: 1982, 46-48) classifies the five physical elements which contribute to the environmental image. In order for a clear city image to be established, these elements are to be strengthened. The manner in which they are patterned together produces a rich urban environment. Each element can contribute to identify and enhance one another.

The five elements consist of:

Paths - Paths are the channels along which the observer customarily, occasionally, or potentially moves. They can consist of streets, paths, railroads or walkways and can be defined as major or minor. (An example is the Tukkies laan pedestrian entrance from Lynnwood road)



Figure 3.8: Paths

Nodes - Definitive points, the strategic spots in a city into which an observer can enter, and which are the intensive foci to and from which people travel with high intensity of use and energy. (An example is the University's main entrance)



Figure 3.9: Node

Edges - Edges are boundaries like shores, railroad cuts, edges of development, walls, etc. There are major prominent edges such as the shorelines, or a series of mountains. There are also minor edges such as a street that separates two neighborhoods. An edge could be a collection of physical elements that form a district. (An example is Lynnwood road that runs parallel to the University's grounds)



Figure 3.10: Edges

Districts - Districts are the medium to large sections of the city, conceived of as having an area, which the observer mentally enters into, and which is recognizable as having some common or identifying characteristics. (An example is the University's grounds)

Landmarks - Landmarks are another type of point-reference, however they are external. They are simply physical elements. The key physical characteristic of a landmark is its singularity, some aspect that is unique and memorable in its context. (An example is the Human Sciences tower on the campus)



Figure 3.11: Districts

Figure 3.12: Landmarks



Secondly we looked at the implementation and use of some of the objectives of urban design as set out by the; By Design, Urban Design in the planning system: Towards Better Practice as published by the United Kingdom planning department. These objectives focus on the design and the form aspects of the built environment that can be used for successful place making.

“Successful streets, spaces, villages, towns and cities tend to have characteristics in common. These factors have been analysed to produce principles or objectives of good urban design. They help to remind us what should be sought to create a successful place. There is considerable overlap between the objectives and they are mutually re-enforcing.”

The Objectives of good place making is defined in By Design as:

- A. **Character** - A place with its own identity
- B. **Continuity and enclosure** - A place where public and private spaces are clearly distinguished.
- C. **Quality of the public realm** - A place with attractive and successful outdoor areas
- D. **Ease of movement** - A place that is easy to get to and move through
- E. **Legibility** - A place that has a clear image and is easy to understand

F. **Adaptability** - A place that can change easily

G. **Diversity** - A place with variety and choice

Secondary to the urban design objectives as stated in `By Design` the following aspects of the built environment play an immense role in the development of successful places:

1. **Urban structure** - The essential diagram of a place
2. **Urban grain** - The nature and extent of the subdivision of the area into smaller development parcels
3. **Density and mix** - The amount of development and the range of uses this influences
4. **Height and massing** - The scale of a building
5. **Building type** - The shape, size and use of a building
6. **Facade and interface** - The relationship of the building to the street





7. **Details and materials** - The appearance of the building

8. **Streetscape and landscape** - The design of route and spaces, their micro climate, ecology and biodiversity



Figure 3.13: Overview of campus districts

Figure 3.14: Campus image and opportunities analysis



3.4 Campus Urban Analysis

To enable the design of an appropriate campus precinct development framework, we as a group had to conduct a thorough urban landscape analysis on the proposed redevelopment zone. To develop performance criteria we used the previously mentioned urban design objects and built environment aspects of form, using these we developed a set of questionnaires and a rating system. The questions are based on the aforementioned criteria and rated on a three level scale Good to Average and Bad. (Appendix A). With these tools in hand we evaluated each area within our proposed precinct development.

This evaluation system enabled us to get a clear picture of what the urban design performance of the area was and where initial and major interventions where required. Further to finding the danger zones it also highlighted the key performance areas to build from.



Figure 3.15: Campus development potential analysis



Figure 3.16: Analysis area



Figure 3.17: Campus urban performance analysis averages





Figure 3.18: Character analysis

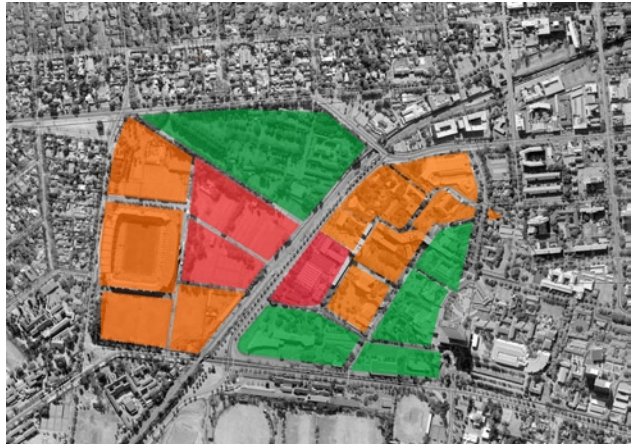

Figure 3.19: Details and Materials analysis



Figure 3.20: Continuity and Enclosure analysis



Figure 3.21: Diversity analysis

Figure 3.22: Density and Mix analysis

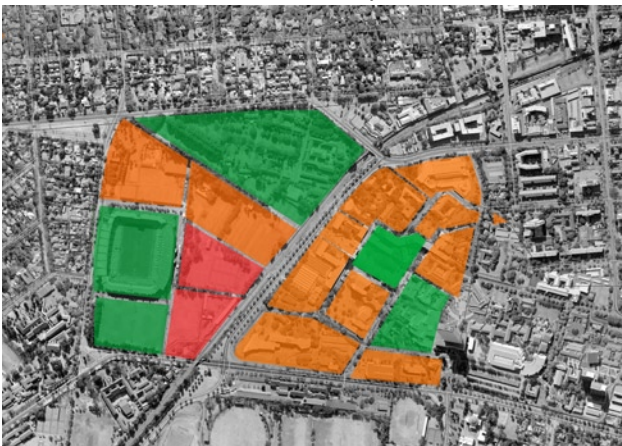

Figure 3.23: Ease of Movement analysis



3.5 Interventions

Phase 1 Initial Intervention:

“...the relationship between different buildings; the relationship between buildings and streets, squares, parks and waterways and other spaces which make up the public domain; the nature and quality of the public domain itself; the relationship of one part of a village, town or city, with other parts; and the patterns of movements and activity which are thereby established: in short, the complex relationships between all the elements of built and un-built space (CABE, 2006).”

The Initial interventions (Phase 1) comprise the implementation of various urban design strategies and protocols. The guiding objectives behind these principles are as set out in the `Vision Statement` for the University`s proposed future development strategy.

The interventions at the urban level on the campus include the implementation of pedestrian network development guidelines, proposal and guidelines for densification and development as well as the reuse of under utilized threshold green spaces.

Pedestrian streets

“Streets are the arteries of our communities – a community’s success can depend on how well it is connected to local services and the wider world. However, it is all too easy to forget that streets are not just there to get people from A to B. In reality they are the tissue that connects and keeps alive the urban body of the campus. They form vital components of residential areas and greatly affect the overall quality of life for local people (Department of Transport, 2007).”

As stated in the UK`s department of transport manual for street design, streets are more than just routes from a to b, and nowhere is this more true than on a campus.

We have proposed three scales of intervention at a street level, each of them suited to a different pedestrian environment. One at a main artery scale,

to accommodate pedestrians comfortably with high speed traffic, secondly at campus ring road scale to accommodate both intercampus vehicle and pedestrian traffic with prominence being given to pedestrians and thirdly at a pedestrian only scale.

Densification

The University of Pretoria’s main campus is riddled with low density low efficiency land use in the form of parking areas and unused threshold green spaces. These areas have been identified as areas that are under utilized and have good development potential without impacting on the community environment that is being developed on campus. The Proposed development of these areas is highlighted in phase two of this framework.

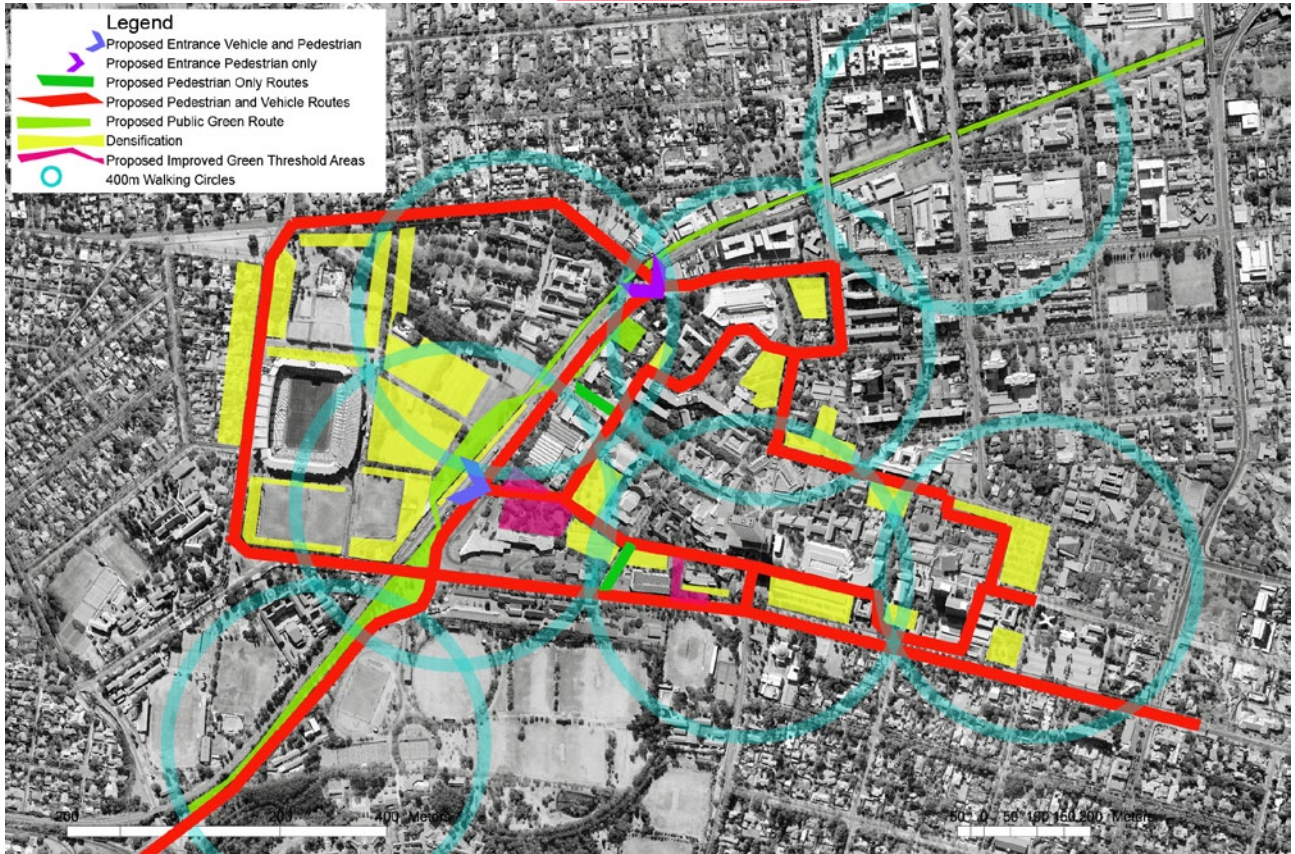

Figure 3.24: Initial Interventions map

Figure 3.25: Urban fabric deviation process

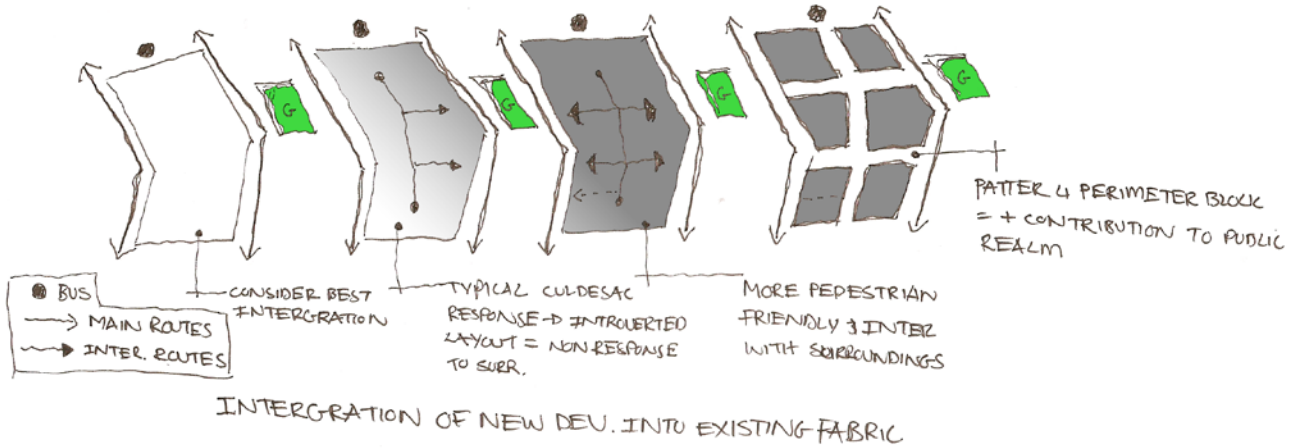
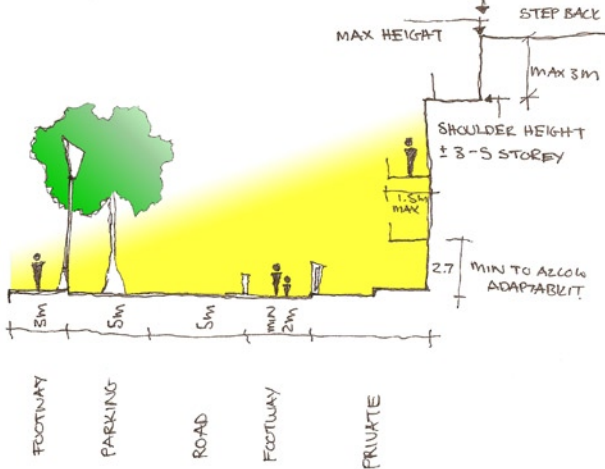



Figure 3.26: Pedestrian friendly sidewalk set out



PEDESTRIAN SPACE NEEDS

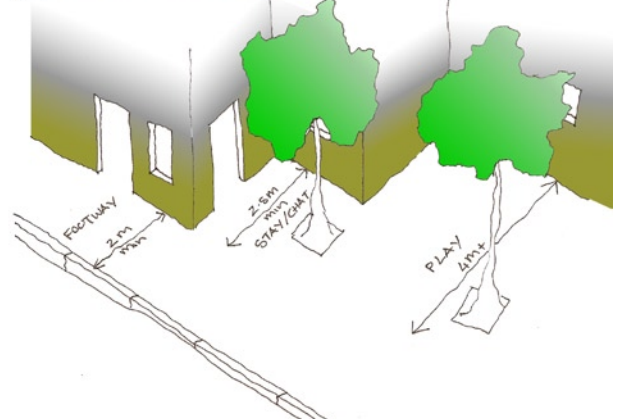

Figure 3.27: Pedestrian spatial requirements

Figure 3.28: Pedestrian sidewalk boundary scale

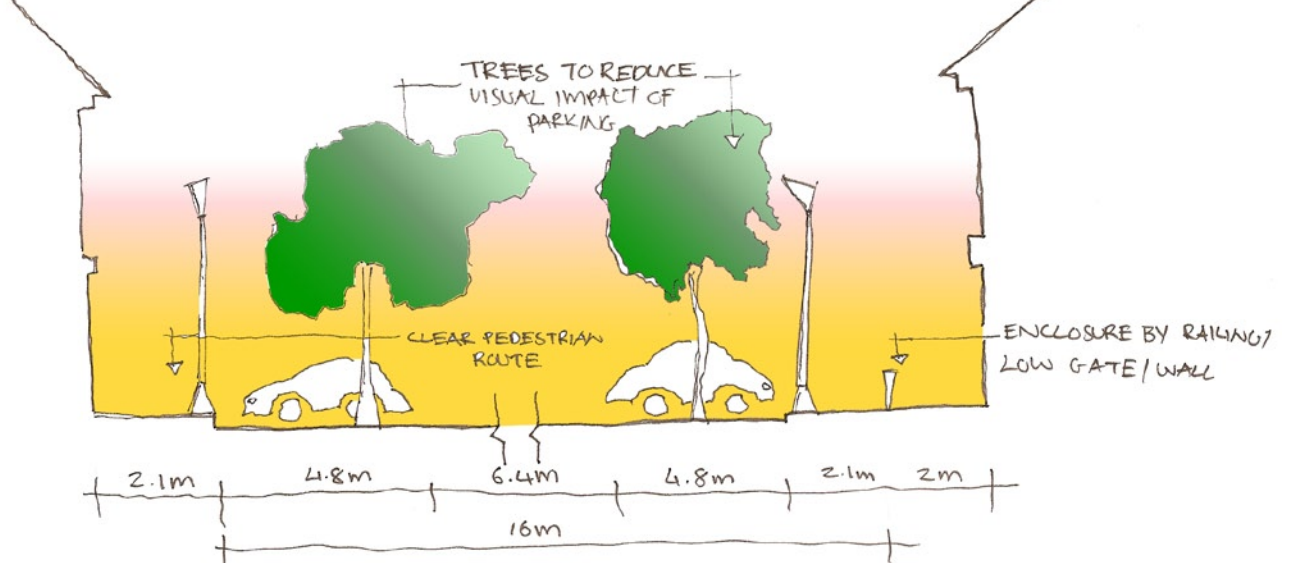
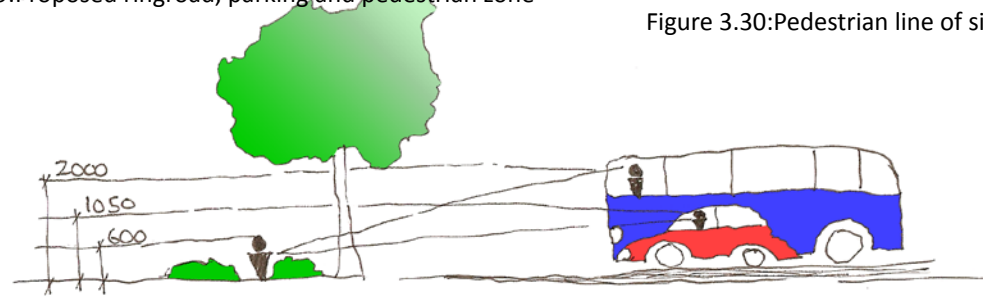

Figure 3.29: Proposed ringroad, parking and pedestrian zone

Figure 3.30: Pedestrian line of sight requirements



CLEAR HORIZONTAL SIGHT LINES SHOULD TAKE INTO ACCOUNT BOTH WHAT THE DRIVER CAN SEE AND WHAT PEDESTRIANS (CHILDREN) CAN SEE. EYE HEIGHT = 1.05m - 2m, OBJECT HEIGHT = 0.6 - 2m



Figure 3.31: Basic street width to height ratios



Figure 3.32: Ringroad intersection proposed raised junction

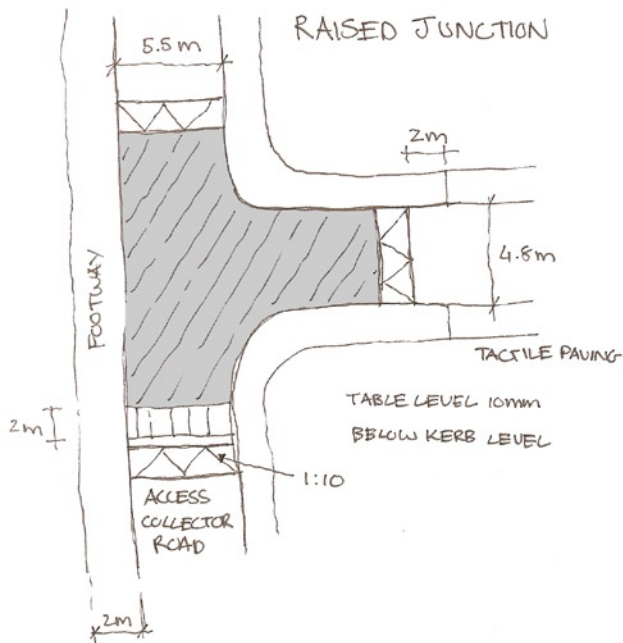

Phase 2 Strategic Interventions:

A

The proposed parking structure is to accommodate current and future campus parking requirements; it is to act as a base structure for future development on the site. The future development should conform to the requirements as set out in the research precinct and urban development frameworks. The parking structure will consist of one basement level and two semi – lower ground levels, it will serve as parking for students, faculty and visitors to the campus as well as the general public during sporting events. The structure should be designed as such to allow flexible planning parameters (structure, services and access) for the future proposed covering development.

B

A research facility that provides new up to date research amenities to the University of Pretoria's top three research fields (Agriculture, Engineering and Natural Sciences). It will service current research requirements as well as be able to adapt to future research demands and technological requirements. The building is situated at the integration boundary between the existing arts precinct on campus and the proposed new research precinct, it thus needs to facilitate the integration and encourage interaction between these diverse precincts.

C

Loftus Metrorail Station

The station is a flagship station, serving the Loftus Versfeld Stadium, the University and surrounding areas. The station has a shopping component and becomes a destination place instead of just a transition space.

Loftus Precinct:

New mixed use development with parking on ground floor level, open courtyard leading up to Loftus Versfeld Stadium (Pre- and Post game get together.)

The aim of the precinct is to create a continuous edge along/beside the sporting activities on Loftus after the divide of the enormous city block into smaller more humane city blocks with pedestrian friendly street interfaces.

D

Sustainability requires a new pathway and our industry must evolve to be a contributor to finding the right answer, rather than delivering the trusted solutions that have served us well in an industry of unconstrained resources.

Aspiration of initiating a dialogue about our professional responsibility. The dialogue must engage with matters beyond engineering and find relevance in the disparate academic research, to drive the pragmatic decision making required by industry.

This thesis is not intended to be the final word, but rather a contribution to the body of knowledge that can be used to focus dialogue in this important area.

Our current methods of evaluating design fall a long way short of meeting the needs of a sustainable future. We have an obligation to embrace the search for ways of quantifying the impacts of our design decisions.

The proposed facility explore, interacts and communicate the profession of architecture through the medium of green technology and at the same time offer entertainment value. Creating a platform for discussion among built-environment professionals to-be, contributing to inform the public and future clientele. Addressing the issues within an educational facility, ensuring skill empowerment within the profession.

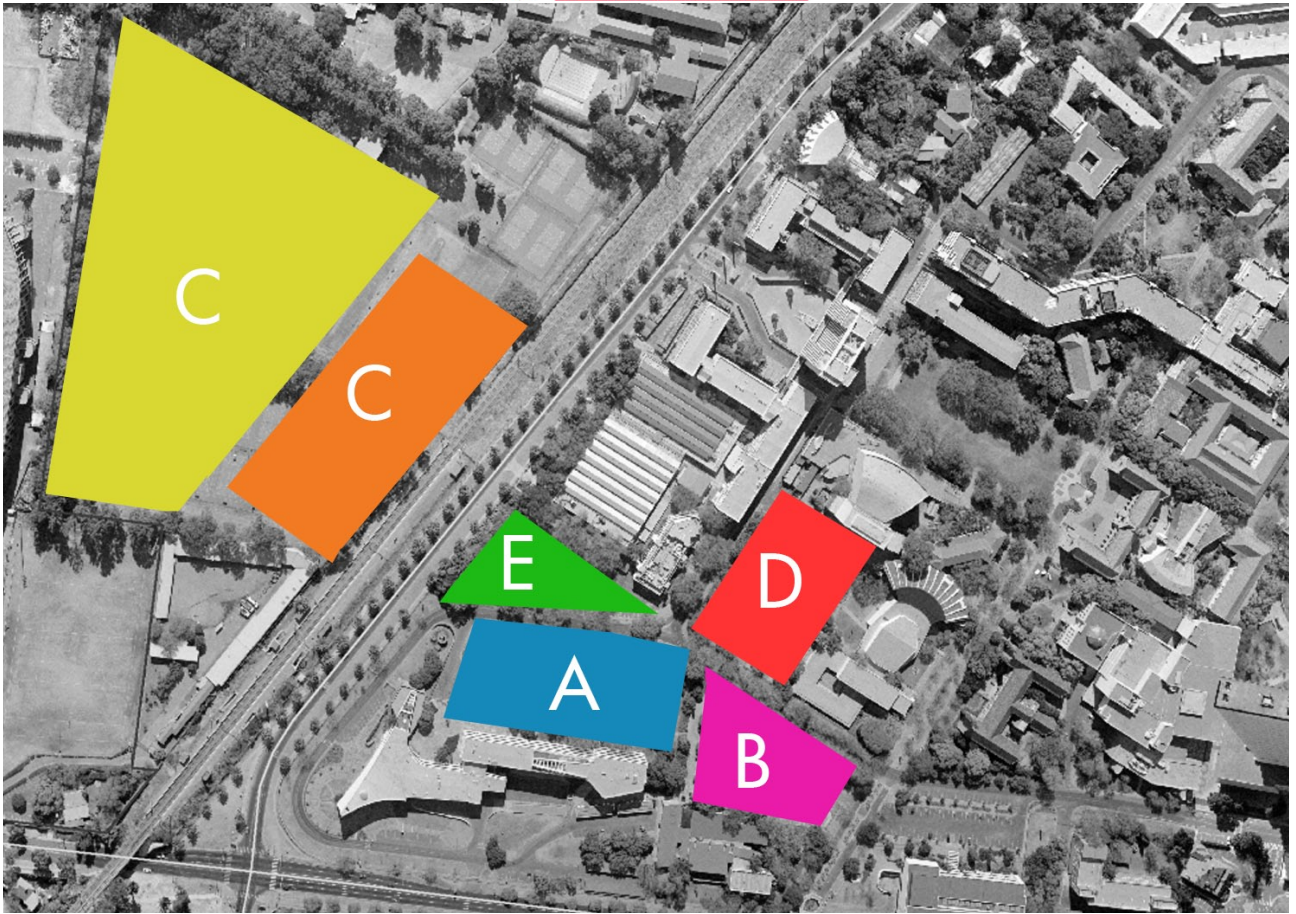

Figure 3.33: Strategic interventions diagram



Phase 3 Key Interventions:

The establishment of a research precinct on the Universities grounds is based on numerous positive objectives. The improvement of access and connection to enhance scientific and academic collaboration and interaction is the key driver to a successful precinct development. The new precinct will serve to develop and sustain a collegial research community where interaction and interdisciplinary research within the community is implied. The new precinct will help to streamline the research processes by, allowing for resource, facility allocation and sharing. The proposed research precinct is located in an area of the campus that has established research facilities in the Microelectronics research building, the Engineering research facility and heavy machinery laboratory, however it is located in an area of the campus that affords the precinct a large area of under utilized space for future developments. Lastly the research precinct is located adjacent to the established arts precinct on campus; the framework is to encourage design that facilitates interaction between these two diverse fields of study, opening up new avenues of study and collaboration.





PROPOSED SPORTS PRECINCT

EXISTING ARTS PRECINCT

PROPOSED EDUCATION PRECINCT

EXISTING NATURAL SCIENCES PRECINCT

PROPOSED RESEARCH PRECINCT

Figure 3.34:Key interventions diagram



UNIVERSITEIT VAN PRETORIA
UNIVERSITY OF PRETORIA
YUNIBESITHI YA PRETORIA





THEORETICAL INVESTIGATION

+

+

INTRODUCTION 4.1

HISTORIC CONTEXT 4.2

SURFACE IN THE PUBLIC REALM 4.3

SURFACE APPEARANCE 4.4

EXPLORING SURFACE 4.5

DEEP SURFACE 4.6



4 Theory Investigation

4.1 Introduction

“Does God judge us by appearances? I suspect he does.”

-W. H. Auden

Architecture appears to the world in the form of images: as our visual perceptions of the built environment, as the “after image” in our minds and as flashes of memory. An after image is defined as the lingering image that is left on the retina after looking at an object or the memory of such an object) The visual element of architecture is indisputable; architecture occupies a human world, a world which it defines and structures. This attribute of building, that is has the capacity, and the necessity to appear, is the one of the greatest powers of architecture. However, no image or appearance can truly be real, without an observant world, in whose perception it must ‘seem’ to exist. If buildings are to embody meaning in the societies which erect it, then its appearance, and therefore its existence must be guaranteed through its relationship with the public realm. (UN Studios, 2007. 370)

Therefore, what is the role of appearance and, with regard to being? Is it merely secondary? Can appearance be a primary effect and device rather than a secondary result? To what extent is appearance reserved to the world of the visual, of the sensual realm of perception, representation, and if so how may it move beyond the perception of the visual only?

Secondly, what defines the appearance of architecture, namely, its surfaces? How should these external membranes be treated, and regarded within the composition of a building, taking into account surfaces significant others; Structure, Interior, Space and Form?



Figure 4.1: Mies van der Rohe`s Farnsworth house



Figure 4.2: Mies van der Rohe`s Farnsworth house



Figure 4.3: Mies van der Rohe`s Farnsworth house



4.2 Historic Context



Figure 4.4: Hans Hollein's Abteiberg Museum

Through architectural history the idea of surface has been formed by two theories: That of Leon Battista Alberti and Gottfried Semper.

"Alberti's search for the authority of surface placed the origins of architecture as being constructed 'naked' and later dressed with ornament. Surface is seen as a resultant condition, one in which surface as an upper outer layer is able to be scraped back thereby revealing the true, inner architectural surface. Under this assumption surface is seen to have thickness that covers and masks".(Taylor, 2003. 32)

"For Semper architecture began with the placing of textile element followed by a solid supporting structure." In the case of the wall, Semper took this motive back to its origin as a hanging textile, a colorful weave providing vertical enclosure. In the case of the Assyrians, "Hanging carpets remained the true walls; they were the visible boundaries of a room. The often solid walls behind them were necessary for reasons that had nothing to do with the creation of space; they were needed for protection, for supporting a load, for their permanence." (Taylor, 2003. 35)

This is paradoxical to Alberti's conceptions. "Semper suggests that architecture turns out to be nothing more than texture. So irrespective of whether the argument concerns clothing or cladding, true or artificial surfaces, the discussion is primarily about 'texture' - a surface characteristic."



Figure 4.5: Michael Graves' Portland Public Service Building

"Semper also noted that the woven surface was first conceived as a method to separate inner life from outer life.", separating public from private. This puts surface as an abstract entity, the first depiction of surface as a non physical concept. (Taylor, 2003. 35)

By accepting these postulations of Semper, one can trace the development of architectural surface in to modernism. Modernism where surface was lost through spatial extension as well as the development of the free facade system that lead to the separation of structure and facade (surface).

It can be argued that Mies van der Rohe might be

Figure 4.6: Charles Willard Moore's Piazza d'Italia



the most prominent example of the development of architectural surface theory in the modern era. Mies treated the wall as an element which is hung free from all load bearing requirements save its own weight, similar to the textile theories of Semper. He used elements usually associated with tectonic performance, the roof and floors as elements used to dress the building and define space. A prime example of Mies's work and the influence of that on surface is the Farnsworth House completed in 1951 as a weekend retreat.



Figure 4.7: Kas Oosterhuis surface explorations

Postmodernism developed as a reactionary force to the accepted `rules` of modernism. Postmodernism in architecture is defined by Stern (1977:275) as having three main areas of definition.

Contextualism: As stated by Stern, the realization that the individual design object should be considered as part of a larger whole. Postmodernism recognizes that buildings, landscapes and objects that refer and defer to their context gain strength over a-contextual designs.

Allusionism: Stern here refers to the extensive quotation from past architectural styles. This practise is not to be confused with mere eclecticism, allusionism proposes that there is a lot to be learned from past styles in various disciplines.

Ornamentalism: Ornamentalism and Allusionism are often partners in post-modern design. However the decoration of surface need not be rooted in historical reference or context, rather it is employed as a tool to gauge human size against buildings.

During post modernism, architectural surface underwent a transformation, from being lost through spatial extension to a load bearing element that is decorated and ornamented superficially with unusually colored, patterned and textured surfaces.

Prime examples of this style of architectural surface include; Hans Hollein's Abteiberg Museum in figure 4.4 (1972-1982), Michael Graves' Portland Public Service Building in figure 4.5 (1980), Charles Willard Moore's Piazza d'Italia in figure 4.6 (1978).

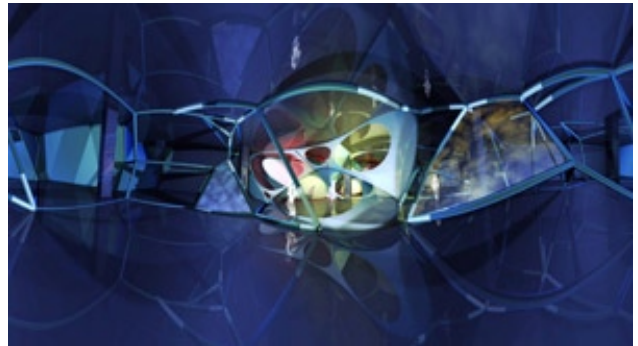
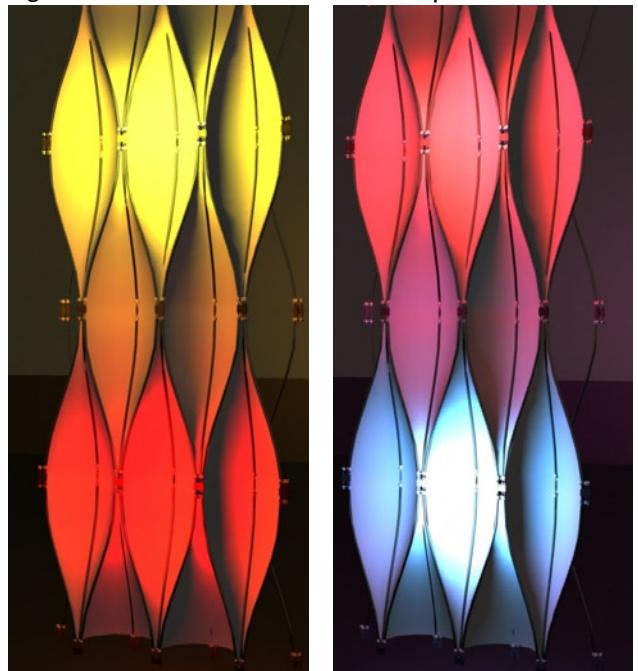

Figure 4.8: Kas Oosterhuis surface explorations

Figure 4.9: Kas Oosterhuis surface explorations



Contemporary architectural surface theory has developed new strands of investigation. Most of these new areas of surface investigation are driven by technological advancement the development of graphic, mathematical, architectural software and powerful computer hardware.

“As a rule technical innovations are nothing other than sophisticated variants of the game of concealing and revealing. However extreme they might be from a technical point of view they always follow the same principle of putting something to service. Thus the most intelligent facades, the most translucent veils and most interactive media facades are not fundamentally different from a classical façade. These filters, dividing de facto two sides from each other while simultaneously connecting them somehow on representational level – half showing their own constructedness and half what lies behind it.”

(Frei, 2003: 44-47)

The question posed here as set out by Hans Frei, is; has architectural surface evolved from the classical concepts of surface, or has new technology merely become yet another representational tool in aid of re-presenting what has gone before? Does technology possess the needed methodology and substance to provide us with new constructs of surface?

Some of the leading contemporary researchers include Deleuze with his investigations of architectural surface and folding and Kas Oosterhuis with his research in to hyper surfaces (living) interactional surfaces).

4.3 Surface in the public realm

For a definition of public and private realms I turn the philosopher Hannah Arendt, in her publication *The Human Condition*, she postulates that there a two main human activities; Work and Labour which take place in two distinct environments: “Labour is the activity which corresponds to the biological process of the human body ... The human condition of labour is life itself. Work is the activity which corresponds to the unnaturalness of human existence ... work provides an “artificial” world of things ...” (Arendt, 1958: 199)

The public realm, in contrast to the private, is a place in which humans appear. As Arendt states, labour a natural condition of human existence takes place in the private realms. Work takes place in public the “space of appearance”, architecture a product of unnatural work has a dual role in the public environment, firstly as a product it serves to stabilise the public realm and secondly it provides the space of appearance required by men to `work`.

Taken together, Arendt’s writings lead us to a conception of the role of architecture as an entity which, while it provides permanence and stability for the public realm, serves a greater value as a physical appearance within and of this realm.

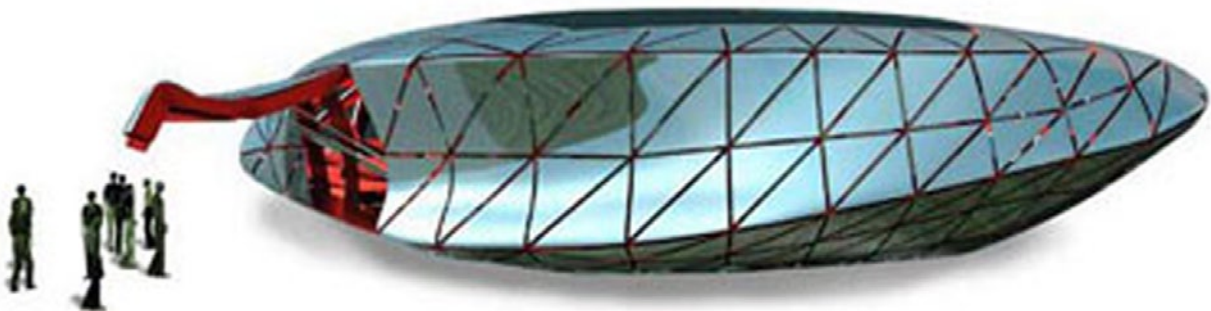

Figure 4.10: Kas Oosterhuis surface explorations

4.4 Surface Appearance

If we accept Arendt's theories, then we may apply this analogy to the building. In so doing, the façade (the external surface) becomes more than mere cladding, its role is far greater than that of protective envelope. Rather, it is the structure, the services, the interior spaces which serve the façade; all else exists so as to permit the surface to fulfil its role, and to appear. This analogy can be taken one step further: if architecture is at the service of certain functions (clients, institutions, users), and these functions are constantly in need of appearance to assert their being in the public realm, then architecture's highest aim must be to provide them with this public appearance for the human affairs which will transpire within the privacy of the physical container.

Surface appearance can be interpreted and investigated greater physical and tectonic depth. Surface appearance can be linked to the 'after image' as described by UN Studios, linked to this conception is the use of surface as camouflage, a surface that responds to and becomes part of its contextual reference frame work. Secondly, a surface that serves the purpose of creating identity and branding.

4.5 Exploring surface

The exploration, testing and evolution of architectural surface as 'Deep Surface' can be seen in chapter 6, design development. As discussed previously the aim of this study is to develop a deep surface in the context of a new research facility. This development will be done at the hand of numerous performance criteria, the 'Deep Surface' criteria as set out below. Environmental performance criteria, including ventilation, daylighting and energy efficiency. Structural requirements as set out in chapter 7, technical investigation. Functional performance criteria including spatial, views and interaction. The final performance criteria that are essential in the development of 'Deep Surface' is contextual, the surface needs to respond to its contextual requirements in an appropriate manner.

The study will aim to use the historic development of architectural surface as describe in section 4.2 as

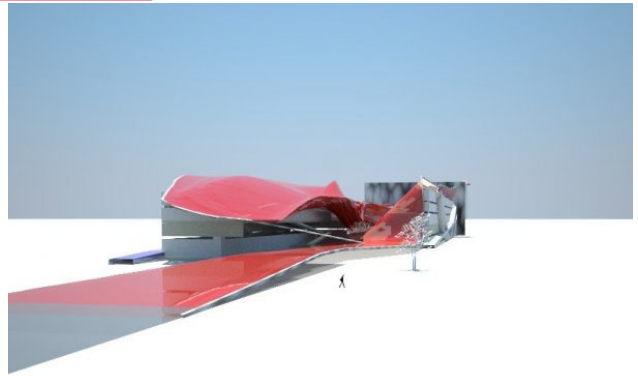

Figure 4.11: International student (Mustav Hamdy) surface exploration

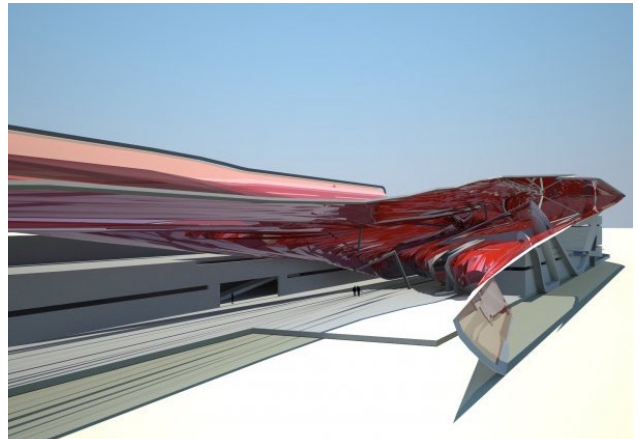
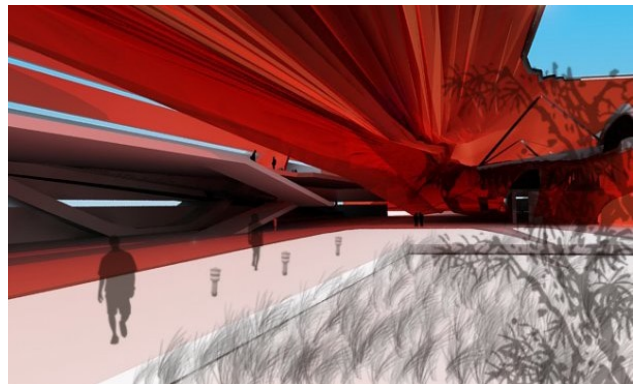

Figure 4.12: International student (Mustav Hamdy) surface exploration

Figure 4.13: International student (Mustav Hamdy) surface exploration



well as drawing from contemporary research as seen in figures 4.11-13, by Mustav Hamdy an architectural student from Israel. Taken together all of the above mentioned performance criteria and the study of past and contemporary theory should lead to the development of surface as a `Deep` construct.

4.6 Deep Surface

Architectural surfaces are and should not be considered as mere membranes restricted to applications of function and form. Surfaces serve a much greater role, that of medium through which architecture and people are able to appear in our world.

The question then is how to design surfaces in direct response to this human need for appearance; and how to create them as representational masks, carrying the memory of the collective public realm. Both Hannah Arendt and Gottfried Semper offer insights towards this question.

Modern building technology, coupled with the infinite possibilities of today's computerized design vehicles offers an incredible array of choices to the architect. However, our society, though extremely superficial in so many regards, seems to reduce perception to the fleeting glance, to the instantaneous image.

The challenge is now to realize a project through which these questions of surface and appearance can be explored; and in which the appearance of a building can be exploited to the highest possible degree as a deep element(in opposition to Semper's theories of surface) that is served by its significant others include services, structure and interior space and as a true embodiment of human intention (per Arendt).



UNIVERSITEIT VAN PRETORIA
UNIVERSITY OF PRETORIA
YUNIBESITHI YA PRETORIA





UNIVERSITEIT VAN PRETORIA
UNIVERSITY OF PRETORIA
YUNIBESITHI YA PRETORIA



PRECEDENTS STUDIES

+

+

LAB PRECEDENTS 5.1

SURFACE PRECEDENTS 5.2

5.1 Laboratory Precedents

5.1.1 Life Sciences Building, The University of Newcastle

Figure 5.1: Circulation Void



The building provides the physical link between the biological and Medical sciences faculties, in order to facilitate interdisciplinary research and communication.

Project: Life Sciences research facility

Location: Newcastle, New South Wales, Australia

Architects: Sutera architects with stutchbury and Pape

Completed : 2000

Introduction

The Life Sciences Building on the University of Newcastle campus has been constructed to house research and teaching laboratories together with lecture theatres and other specialist operations within the faculty schools of medical and biological sciences. The environmental demands required the natural landscape of a very steep site beneath the building to be retained. The design and construction of the building therefore necessitated innovative architecture. (Structural Concrete Industries, 2002)

The architectural concept provides for the building to cantilever over the site in two directions - twenty-one metres out to the north on the longitudinal axis and six metres to the west on the transverse axis. Two large inclined hinged struts support the main longitudinal cantilever. (Structural Concrete Industries, 2002)

Considerations

The facility is implemented to facilitate interaction between research disciplines in a physical and spatial sense. It accomplishes this by becoming the connecting bridge between two worlds. While achieving this most important of research facility design it also tackles the contemporary laboratory design issue in the following manner:

Accommodation - The facility provides for all of the possible occupants by providing teaching and research labs, staff offices, tutorial and post graduate student offices.

Programming - The programming is consciously designed with clustering of related function and the offset of open versus closed research labs. The design also employs a simple sectional design, moving from east to west the implementation of zones (Office - Circulation void - Lab Support - Lab - External Services) to structure the facility.

Sustainability - Further the architects employed a passive ventilation strategy in all non-controlled environments.

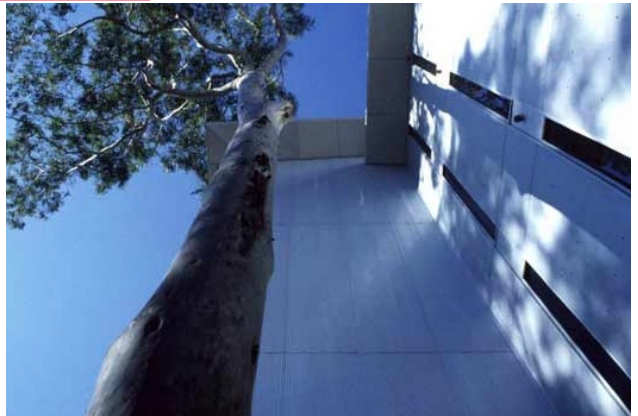
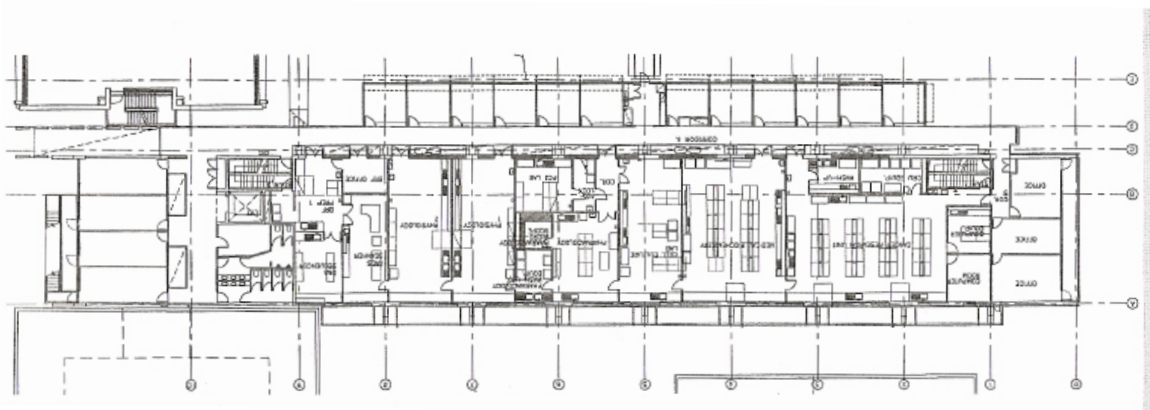

Figure 5.2,3: External views of facade

Figure 5.4-6: Interior and exterior views of building



Figure 5.7: Facilities plan



5.1.2 Boeringer Ingleheim Pharmasuetical Research Lab

Figure 5.8: Glass Louvre Facade



A long seven story exploits the predetermined building envelope to the full, facilitating a direct connection to the exiting adjacent building. Its spacious ground floor foyer provides the unifying element which focuses various views on the surrounding campus

Project: Boeringer Ingleheim Pharmasuetical Research Lab

Location: Biberach Germany

Architects: Sauerbruch Hutton Architects

Completed : 2002

Introduction

The building consists of two parts: A naturally ventilated office area to the west and a laboratory zone to the east. The atrium that lies in between allows the two parts to communicate, natural daylight to penetrate and passive ventilation to take place.

The colourful glass louver skin unites the various diverse parts in to a whole. It serves as a layer of adjustable sun shades and generates a striking and contemporary image which is intended to symbolize the world of research and to set off Bibreach as a research location.

Considerations

The design implementation of contemporary interactional and sustainable techniques is what truly sets this facility apart from its peers.

Programming - The separation of research laboratories, office and support zones afford flexibility to the building. The use of a linking atrium zone to facilitate orientation and interaction is us implemented successfully in this facility

Design - The unique coloured glass louver facade system affords the facility the development of a unique identity and character. Further it also allows the development of exiting and stimulating research spaces.

Sustainability - The central connective atrium plays a key role in the passive climate control strategy in this facility. The atrium allows natural daylight to penetrate deep in to the facility, it allows for passive buoyancy ventilation in the non controlled passive office spaces, as well as passive night time cooling.

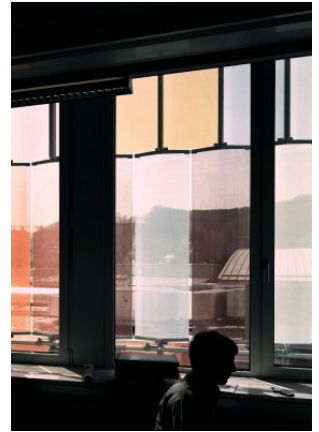
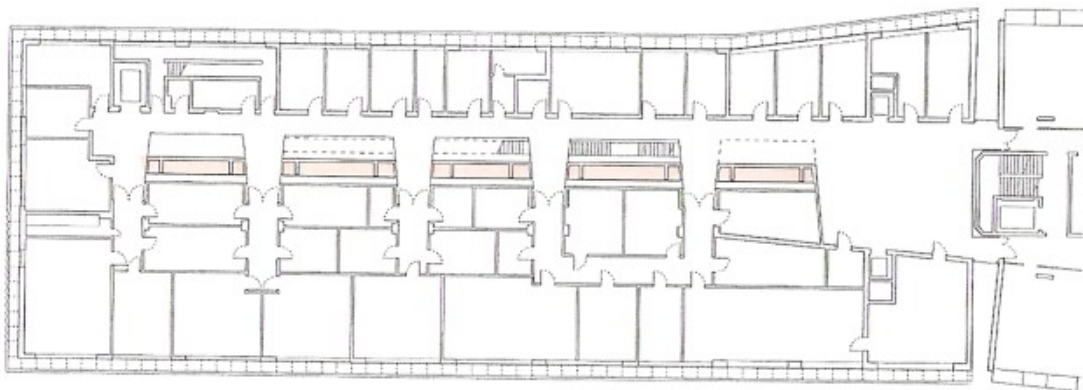

Figure 5.9-11: Exterior and interior views

Figure 5.12-14: Facade design



Figure 5.15: Plan Facilities



5.1.3 Clark Centre (Bio-X Research Centre)

Figure 5.16: Clark center central courtyard



“Providing laboratory, office and social spaces for 700 academics from the Schools of Humanities and Sciences, Engineering and Medicine, the Clarke Centre is strategically located at the heart of the campus, between the core science and engineering buildings and the medical centre. It acts as a social magnet for the University, encouraging students, lecturers and researchers from diverse disciplines to mix, (<http://www.fosterandpartners.com/Projects/1076/Default.aspx,02/10/2008>).”

Project: Bio-X Research Facility
Location: Stanford, USA
Architects: Foster and Partners
Completed : 2003

Introduction

“In striking contrast to the traditional laboratory facility with its closed rooms and corridors, the Clark Centre is open and flexible: external balconies replace internal corridors and laboratory layouts can be re configured at will. All benches and desks are on wheels and can be moved to allow ad hoc team formation that can respond easily to fast-evolving research needs. This versatility is further enabled by workstations that plug into an overhead unistrut system of exposed services and flexible connections.

Externally, the three-storey building takes the form of three wings of laboratories, clad in rust-red painted steel and limestone to echo the tiled roofs and stone facades of Stanfords architectural vernacular, that frame an open courtyard overlooked by balconies. A forum at the heart of the courtyard is used for exhibitions, concerts and other events, while a restaurant on the ground floor of the south wing offers a new social focus for the entire campus with tables spilling out into the courtyard (<http://www.fosterandpartners.com/Projects/1076/Default.aspx,02/10/2008>).”

Considerations

The Bio-X centre was designed to challenge the stigma of labs as closed, private sealed and dark places. The design focused on opening up research, flexibility and interaction.

Programming - Laboratories were designed as generic modules that can adapt to any research requirement. Further the labs were designed as open entities in a physical and abstract sense. To allow this flexibility and openness of space the facility was programmed in zones, with fixed core services and facilities zones.

Structure - The structure of the building allows clear structure free spans within the research environments, allowing a much greater flexibility of space

Services - Services in the research labs are distributed on a flexible hose system supplied on a unistrut ceiling grid system at 3m intervals. This allowed total flexibility and adaptability of space and lab layouts. Mobile case work further enhanced the research experience.

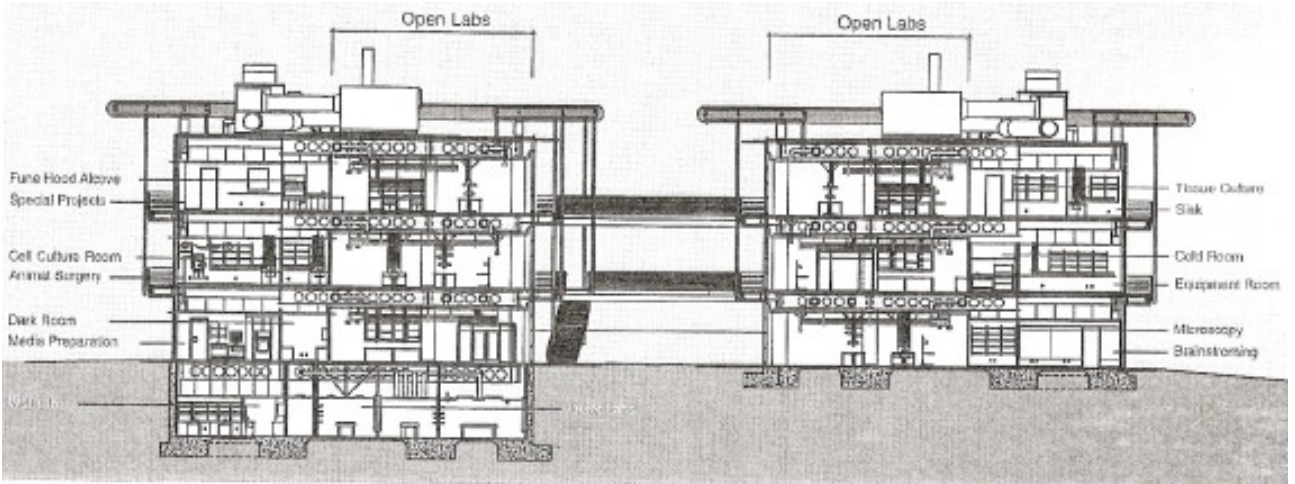

Figure 5.17-19: Internal courtyard views

Figure 5.20-22: Interior spaces



Figure 5.23: Facility Section



5.2 Surface Precedents

5.2.1 Blizzard Building



“Our aim has been to create a space that avoids the traditionally sanitised environment of laboratory research buildings - here the very fabric of the building speaks about science and is conducive to better science by bringing researchers together.”

Will Alsop

Project: Queen Mary Medical Sciences Research Institute

Location: Queen Mary University London, UK

Architects: Will Alsop

Completed : 2005

Figure 5.24: Atrium with pods

Introduction

“Aiming to create an outstanding new building for the College, plus a significant landmark and educational resource for the local community, the design team developed the building’s form around two primary concepts; firstly to foster better integration of the science disciplines through the provision of an open-plan environment; and secondly to create a building which broadcasts its purpose, achieved by the development of a seductively transparent building envelope.

400 scientists will, for the first time in the UK, work side by side in an open-plan work environment on a vast single research floor conducive to improved communication and the cross fertilisation of ideas. Supporting amenities are located in a series of pods suspended above the open-plan laboratory floor(Kiser, K. 2005).”

Considerations

Will Alsop architects designed this facility to completely break with the tradition of the stereotypical research laboratory. The creation of a truly unique and innovative research environment is what set this design apart from its peers.

Accommodation - Unusually for its type the research facility is clear and open. The great open plan research floor provides functionality to the research disciplines whilst allowing the flexibility necessary to accommodate their changing needs over time.

Transparency - The selectively transparent envelope permits the internal activities to be seen and so doing engages the surrounding community, however it maintains actual and visual security required.

Programming - The interior breaks with tradition in a number of ways, providing the ideal setting for collaboration as well as staging and inspiring research environment.





Figure 5.25: Interior of one pod



Figure 5.26: Facade of Building



Figure 5.27: Mezzanine level circulation

Figure 5.28: Connecting bridge of building



Figure 5.29: View of research floor and pods



Figure 5.30: View of research floor and pods

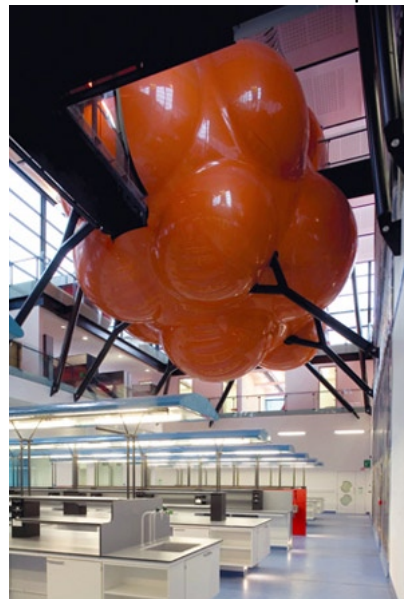

5.2.2 Prada Store

Figure 5.31: Exterior night time view of prada store



“The Tokyo store is a strikingly unconventional 6-story glass crystal that is soft despite its sharp angles – as a result of its five-sided shape, the smooth curves throughout its interior, and its signature diamond-shaped glass panes, which vary between flat, concave and convex ‘bubbles’ (Glynn, S. 2005).”

Project: Prada Flagship store
Location: Tokyo
Architects: Hertzog and de Meuron
Completed : 2003

Introduction

“Though it might appear capricious, the irregular geometry of the tower is in fact dictated by Tokyo’s complex zoning and planning laws that have shaped and eroded the basic six-storey block. Herzog & de Meuron’s early exploratory models resembled roughly carved pieces of ice, now evolved into a more streamlined and tautly chamfered form. This is wrapped in a rhomboidal grid, like a giant fishing net (or string vest), in filled with a mixture of flat, concave and convex panels of glass. Most are clear, some, where they enclose changing rooms, are translucent. The convex panels billow out gently through the grid like bubbles or puckered flesh. Cunningly, there is no single focal shop window; rather the entire building is a huge display case, generating faceted reflections and an array of changing, almost cinematic, views from both outside and inside. At night, light pulsates through the crystalline lattice, tantalizingly exposing floors of merchandise (Glynn, S. 2005).”

Structure - The use of a structural rhomboid lattice frees up the interior space of the facility from structural support constraints.

Surface - Here H&D explore surface as a transparent, translucent crystal like structure, giving character and identity to the building.

Tubes - The tubes act as the only private spaces within the facility and allow more personal spaces and activities to take place.

Considerations

Architectural surface exploration is always at the forefront of Hertzog & Demeurons designs. In the prada store the exploration continues with the use of a rhomboid lattice structure and tube structures, that define a new surface exploration and opens up new possibilities.



Figure 5.32-34: Spatial development of building

Figure 5.35- 39: Views of rhomboid lattice structure



Figure 5.40-43: Interior and exterior view of prada store



5.2.3 Seattle Library

Figure 5.44: Side walk view of library



“The stacks, arranged along a continuous spiral ramp contained within a four-story slab, reinforce a sense of a world organized with machine-like precision.”

Nicolai Ouroussoff - Los Angeles Times

Project: Seattle Public Library

Location: Seattle, USA

Architects: OMA (Rem Koolhaas)

Completed : 2003

Introduction

“Collection of books, government publications, periodicals, audio visual materials and the technology to access and distribute information from the physical collection online. The building is divided into eight horizontal layers, each varying in size to fit its function. A structural steel and glass skin unifies the multifaceted form and defines the public spaces in-between(Kiser, K. 2008).”

Considerations

In the new library the formal exploration is what intrigued me the most. The exploration of appropriate architectural form and space related to a specific function.

Form - The facility is developed in terms of five platforms, each platform is designed to meet the functional requirements for that space.

Surface - OMA chose to unite these five platforms using a lattice frame surface. The steel structure, wraps and covers the entire building, clothing all of the platforms and adapting in density and form to their requirements.

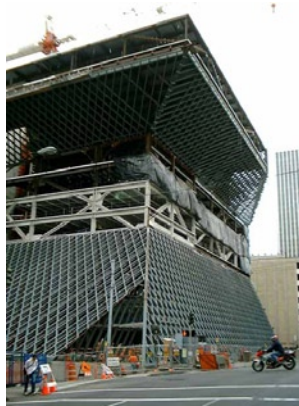

Figure 5.45-47: Facade lattice structure

Figure 5.48,49: Construction details

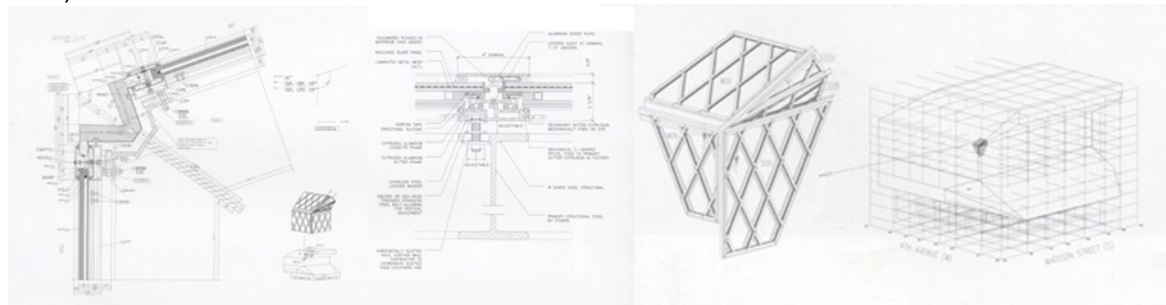
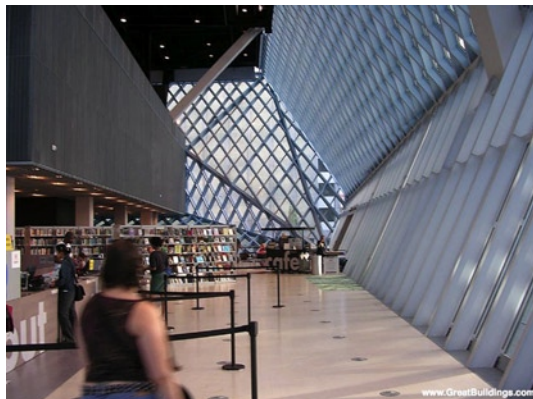
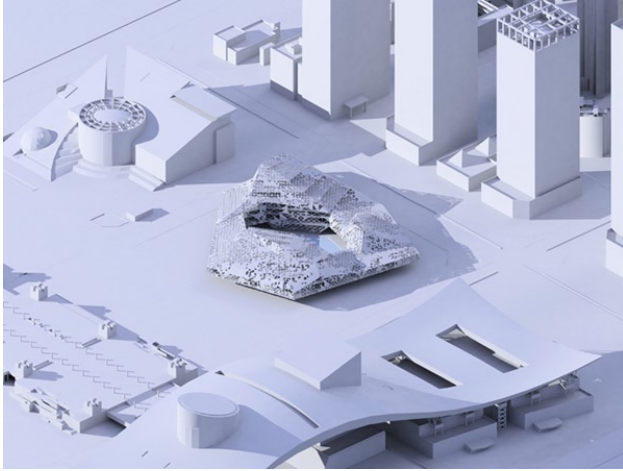

Figure 5.50-52: Construction, Interior and facade design views



5.2.4 AUTOLITH

Figure 5.53: Conceptual context rendering



Project: MOCAPÉ, museum of contemporary art & planning exhibition shenzhen
Location: City of Shenzhen, China
Architects: SERERO Architects
Completed : International Competition, Finalist 2007

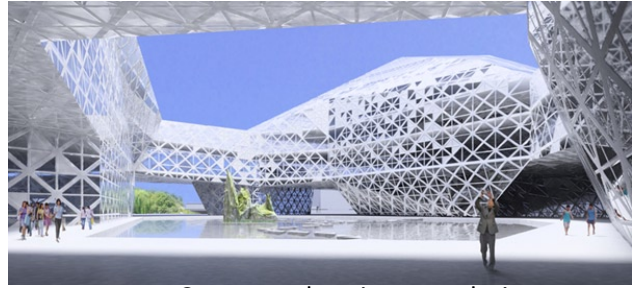

Figure 5.54-57: Conceptual projects renderings

Introduction

“The MOCAPÉ façade and rooftop system is a continuous surface with glass and steel cladding, which wraps around the whole building. Like the ancient Chinese puzzle, the Tangram, this surface is composed of triangular and square panels. They are creating at 3 different scale a set of figures (both abstract and figurative) which are endlessly changing the amount of light penetrating in the museum spaces and filtering the views to the surrounding buildings and to the museum interior courtyard.

The façade is a structural lattice, which operates at different scale. It combines photovoltaic panels to offset the building energy needs, as well as automatic solar shade systems included in the thickness of the glass to control the museum interior environment (Serero Architects. 2007)”

Considerations

I studied Serero`s competition entry to better understand the intricate detail that could be developed with the use of a lattice surface structure.

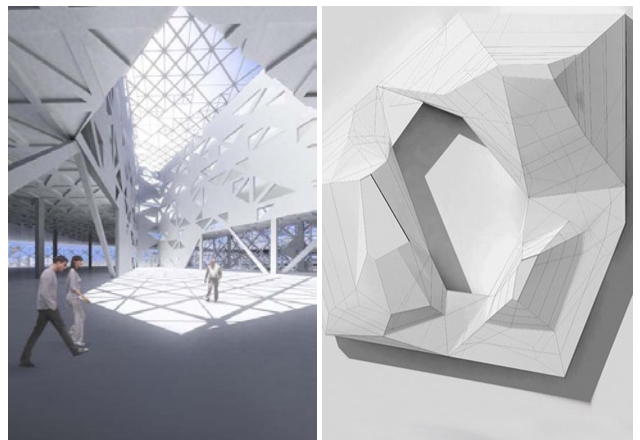
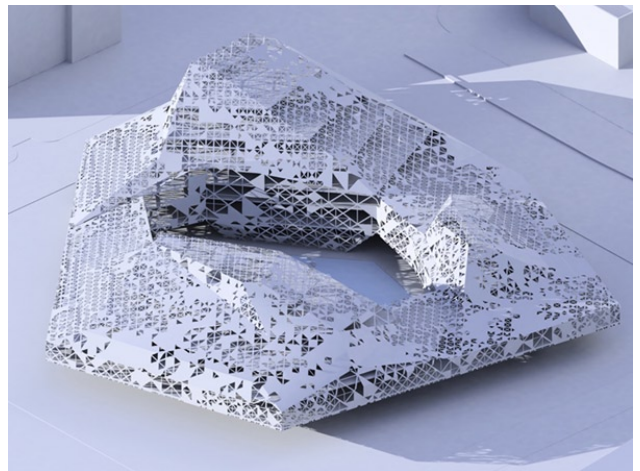



UNIVERSITEIT VAN PRETORIA
UNIVERSITY OF PRETORIA
YUNIBESITHI YA PRETORIA



UNIVERSITEIT VAN PRETORIA
UNIVERSITY OF PRETORIA
YUNIBESITHI YA PRETORIA





DESIGN INVESTIGATION

+

+

INTRODUCTION 6.1

SURFACE 6.2

FORM 6.3

INTERVENTION 6.4

6.1 Introduction

The theory chapter concluded with the discussion of deep surface, architectural surface as a representational and spatial tool. Deep surface is identified as an architectural element that is defined by its significant others and visa versa. This chapter seeks to show the development of architectural surface in the research facility and its significant others; Structure, Space and Services. Secondary to the development of and exploration of deep surface as a concept this chapter also tracks architectural surface as and element capable of camouflage and branding.

The design development of the research facility will be studied in three main sections including Surface, covering the conceptual, structural, skin and spatial design and development of the building surface. Secondly the chapter will look at the formal exploration and design covering key aspects including; views, circulation and orientation.



Figure 6.1: Study of people in landscape as source of light



6.2 Surface Development

To develop an appropriate architectural surface a dynamic contextual response was required. As indicated in chapter two there are a number of key defining characteristic dominating the site. `Surface` had to respond to, define and be defined by these key elements.

A. The first of the elements is the nature of the site. The site`s contextual feel is that of an intimate, small scale and isolated mini precinct.

B. Trees define the boundaries of the site, they enhance its natural character and provide excellent passive climate control on site.

C. Movement, as the site is located at a crucial intersection on campus where the main vehicle route (ring road) and one of the main pedestrian routes (Tukkie laan) cross. As well as being the gateway to the administrative heart of the campus, it is a site that is bordered by and shaped by movement.

D. Iconic buildings on the campus landscape border the site on all sides, from large impressive brutalist concrete buildings to more intimate facilities. Two of the site`s four neighbours are iconic in their own right and the other two understated yet important in their own right.

From these four key contextual indicators I developed certain performance criteria to help guide the surface development. Further to the contextual performance criteria the exploration also demanded the development of performance criteria for Structure, Space, and Services.

6.2.1 Performance Criteria

Context

1. Recreate or enhance the intimate feel of the site.

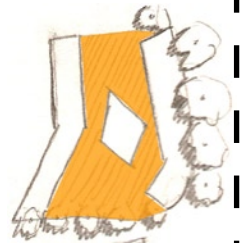

2. The trees on site should be used as generative image and texture

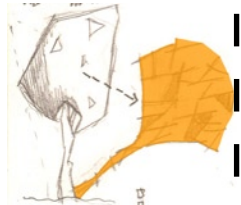

3. Enhance and streamline the movement on and next to the site

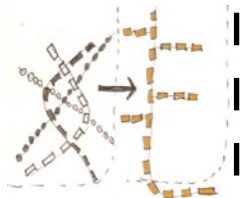

4. Respect iconic neighbour buildings and do not dominate





Structure

5. The surface structure must provide obstruction free interior space within the facility

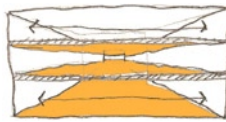

Image

9. The surface must create a unique identity for the research facility and discipline on campus.

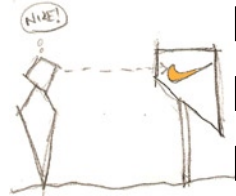

Space

6. Spatially the proposed surface must act as a defining element and enhance the deep surface concept.



Services

7. The surface element must provide for the functional requirements of a research facility by accommodating services.



Environment

8. Environmental requirements must play an active role in the shaping and design of the surface.





6.2.2 Conceptual 'Skin' Development

Taking in to account the above set out performance criteria, the surface that has to be developed is a complex entity, requiring the input of numerous indicators. From an analysis of the indicators a number of appropriate conceptual responses can be **'generated'** . In progressive practises like Serero from France and their peers, this would be a matter of introducing these parameters to generative design software coupled to a main frame hardware system, generating infinite solutions from the parameters.

However due to the constraints and lack of software, hardware and knowledge this was not an option that was available to me. Thus I set out to develop an analogue generative system that might give me glimpses of the possibilities inherent within these parameters. The analogue generative process considered the following elements; Structural grids, images, Structural requirements, Space and environmental influences.

Following are two of these analogue generative studies.

Generate A , shows the development of a surface with a structural and aesthetic quality that can be traced back, directly to the image that defines it.

Generate B shows how by varying the input in only a slight manner develops a completely different result. These studies were invaluable in terms of understanding the problem at hand and although they did not directly develop the final surface, they influenced the final surface development, and aided in its development.

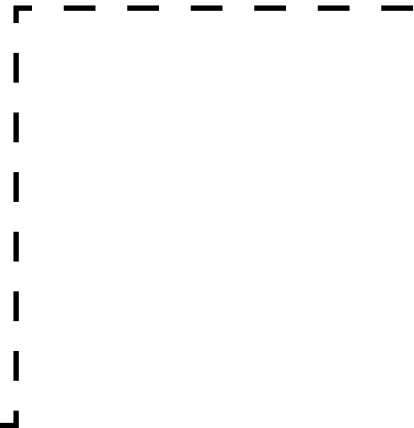

Generate A

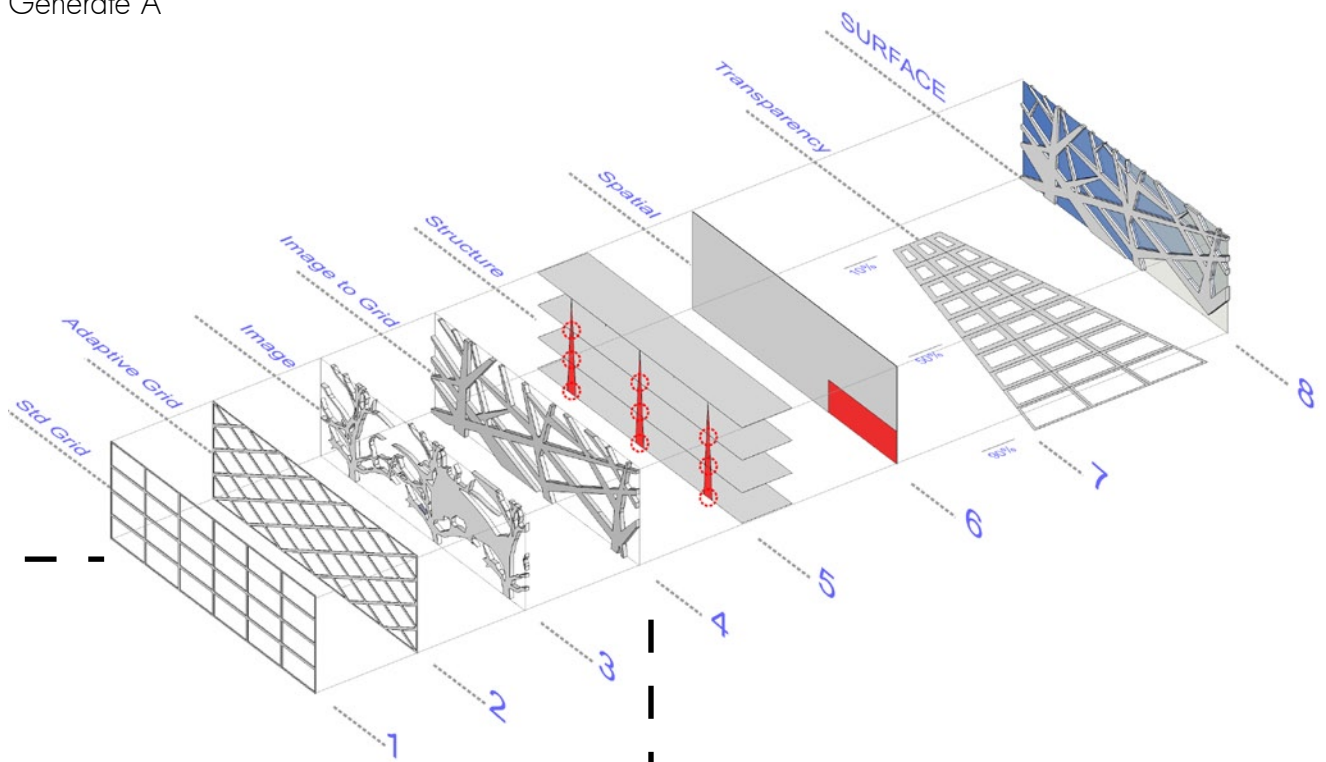
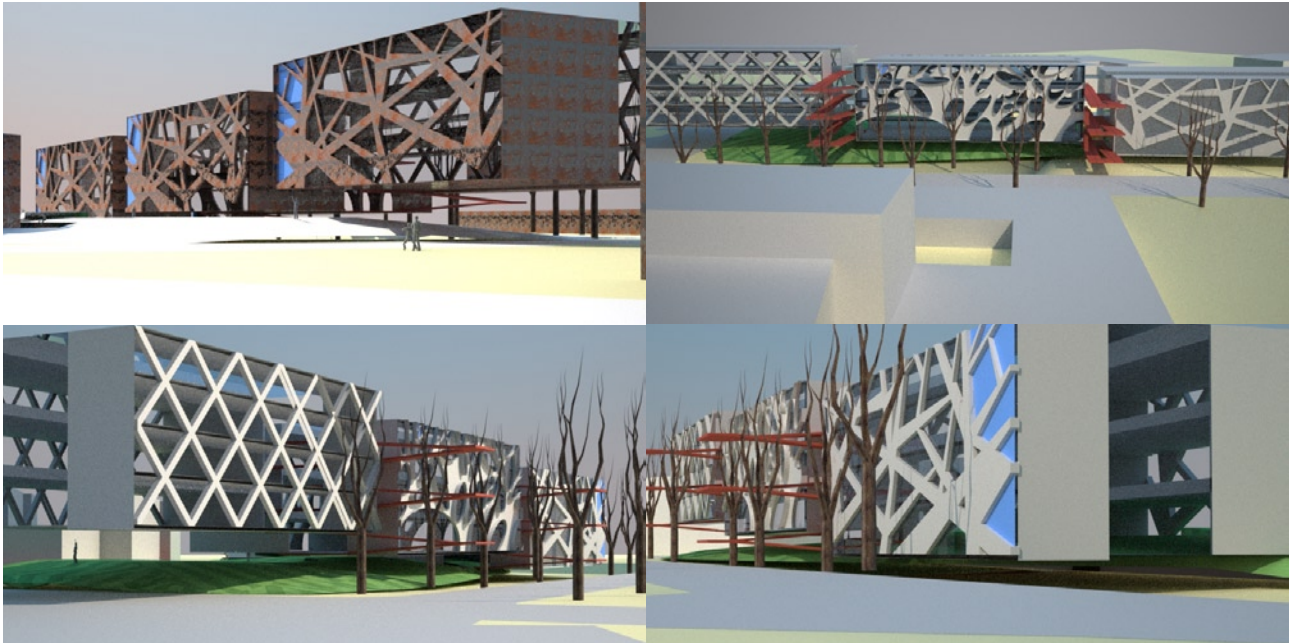

Figure 6.2: Analogue Generative process A

Figure 6.3-6: Conceptual facade studies from analogue generation process



Generate B

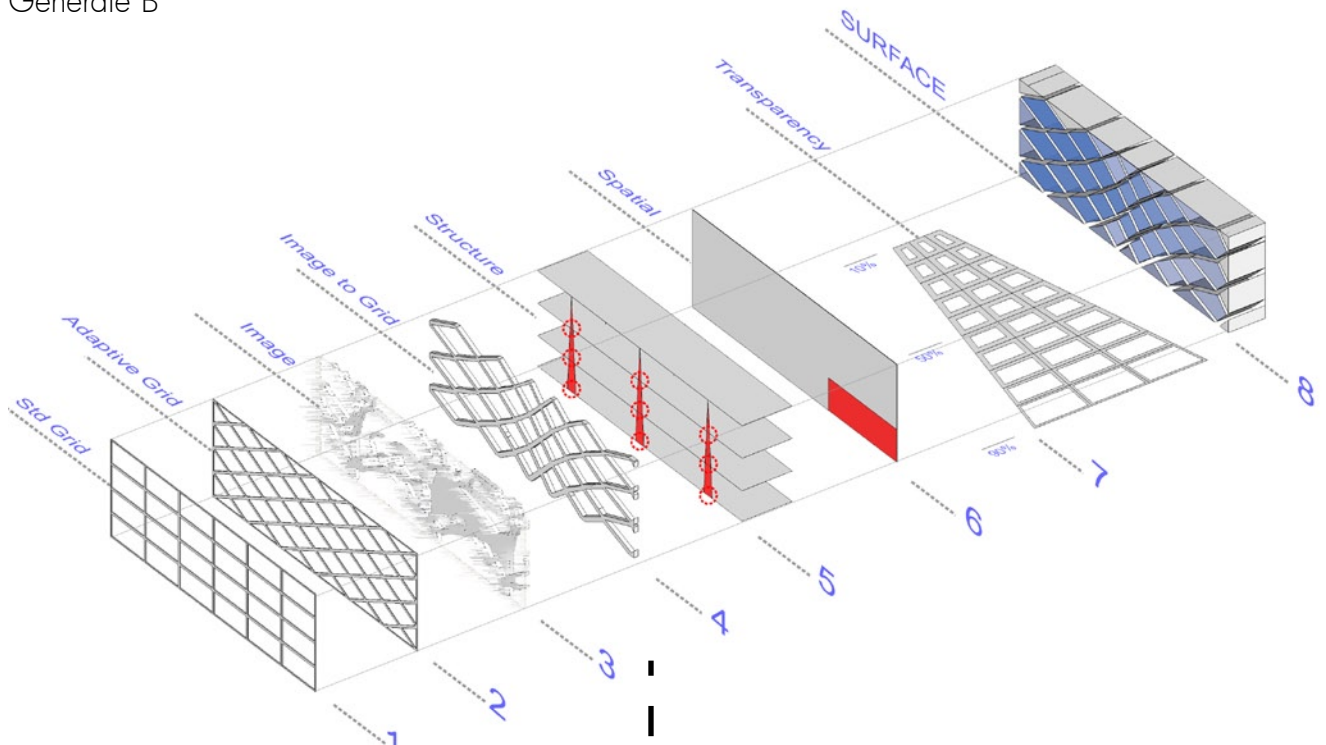
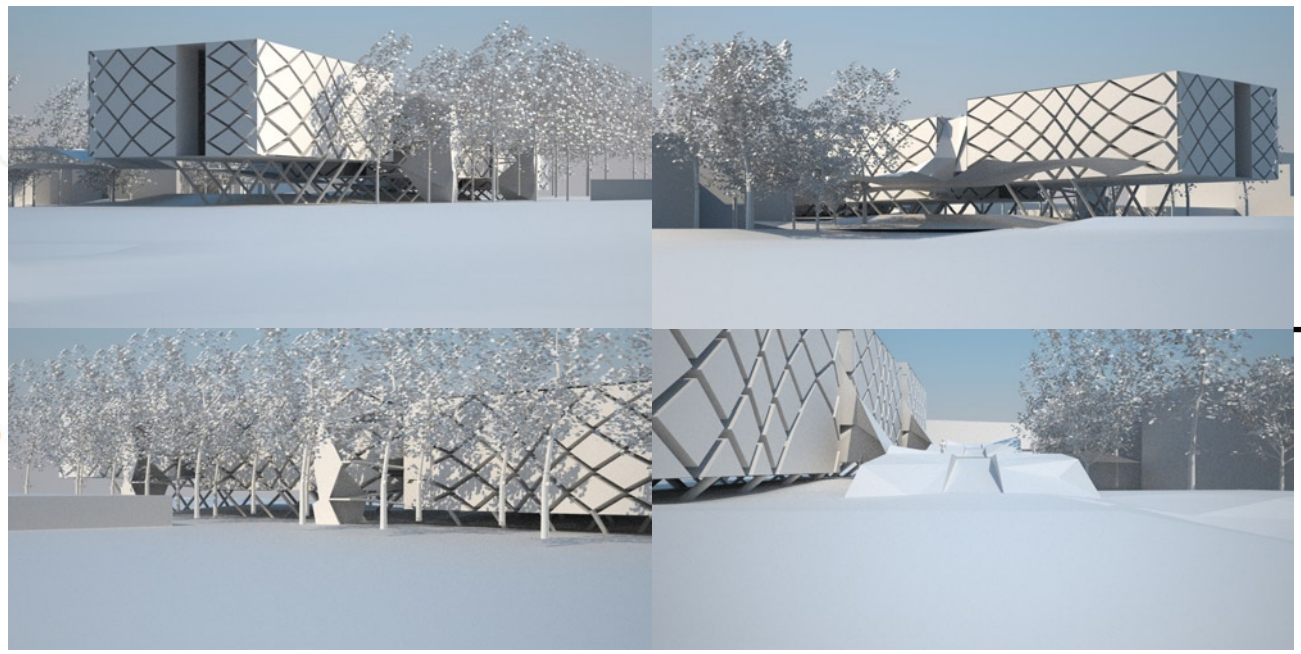

Figure 6.7: Analogue Generative process B

Figure 6.8-11: Contextual facade studies from analogue generation process B





Below follows a description of the generative system as developed during the generating process. It gives a brief description of each of each of the stages of the surface development.



Generate B : deep surface generative process

- 1 - Std. grid is seen as the optimum division of grid on 2d plane taken a contextually
- 2 - Consideration of 3d and structural requirements leads to the development of the adaptive grid
- 3 - The new cells formed by the adaptive can be considered at optimum performance level, which is then applied to a pattern generating image
- 4 - The application of the `image` transforms the adaptive grid from static to dynamic `undulating` grid
- 5&6 - From the development of the dynamic grid the generation process the application of structural and spatial requirements (load transfer, connection point ,openings ect.)
- 7 - To generate final layer of the deep surface requires he application of a transparency graph (i.e. Opacity)



6.2.3 Surface Structure development

“The architect who considers him or herself to be an artist, dealing through the medium of built form with the philosophical preoccupations of the age in which he or she lives, is surely engaged in a titanic struggle. One aspect of that struggle is the need to determine building forms which are structurally viable. All artists must acquire mastery of the technology of their chosen medium but few face difficulties which are as formidable as those who choose buildings as their means of expression. The sculptor has to contend with similar structural problems but his or her difficulties are trivial by comparison with those of the architect. The difference is one of scale the size of a building, compared to that of a work of sculpture, means that the technical hurdle which must be surmounted by the architect is of a different order of magnitude to those which are faced by most other artists. The structure of a building is the armature which preserves its integrity in response to load (Macdonald, J.)”

Figure 6.12-16: Structural development studies

Figures 6.12-16 show the development of a structural system that uses the image of the tree and its natural branching in a rigid triangulated grid, however this system was deemed unsuitable due to its restrictive and cluttered nature. However in this system the effective nature of the tree structure in terms of a solid to light structure is identified.

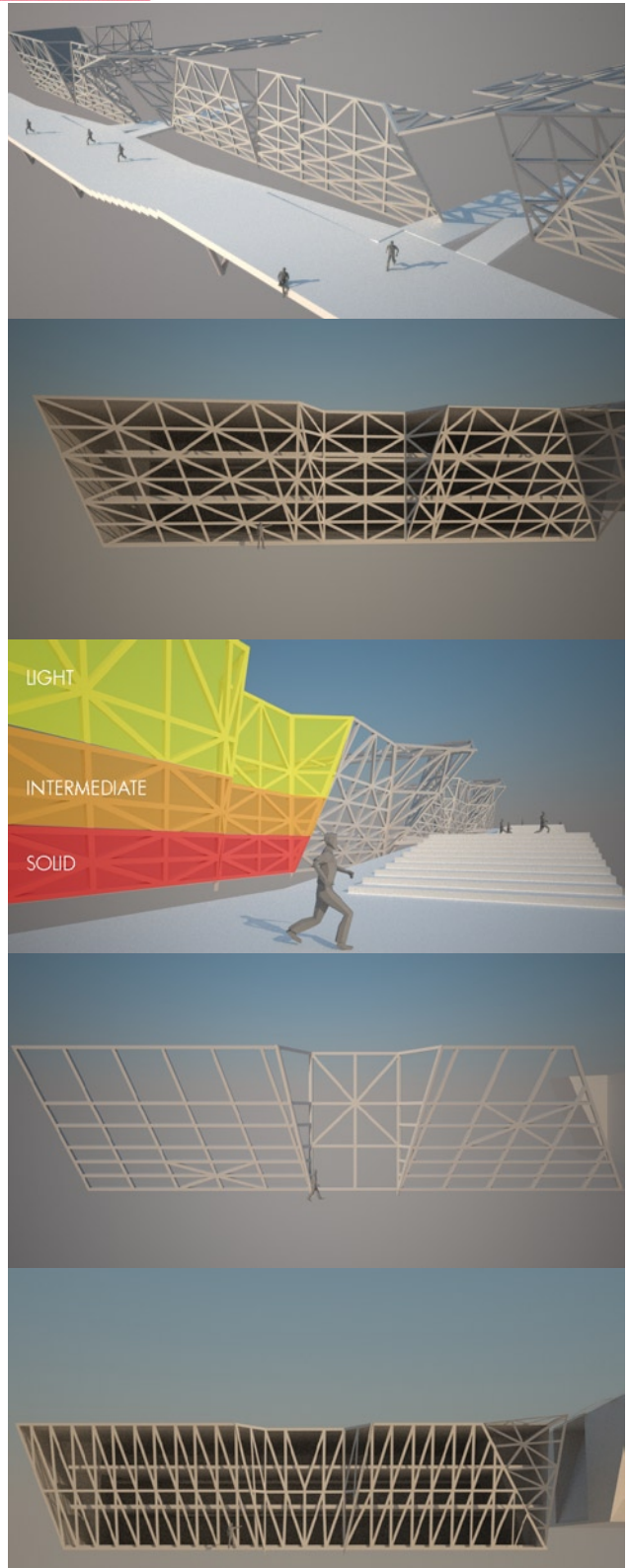

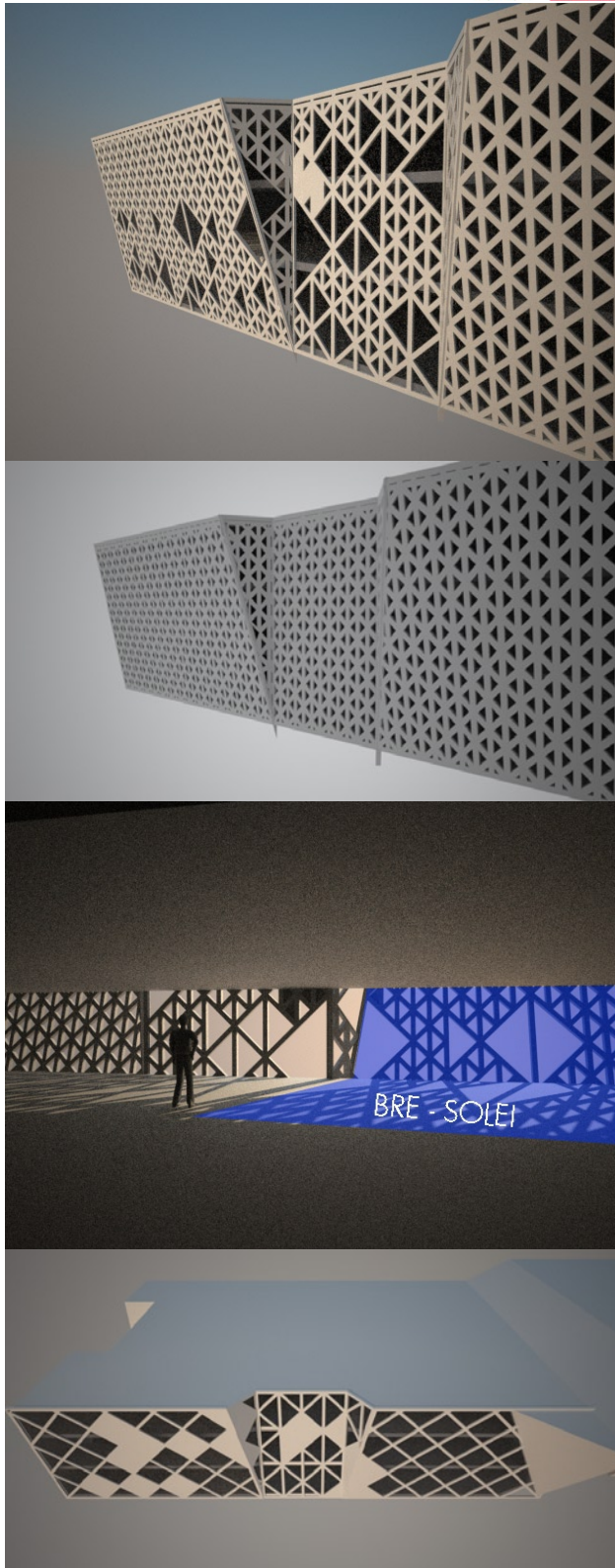

Figures 6.17-20 illustrates the development of a structural system, focussing on a part of the image of the tree, the triangulated structure. This structure was also deemed unsuitable. Another important component of the final structural design was identified. The fact that the structure could act as an environmental control element. Further was the appearance of the structure at human scale and eye level.

Figure 6.17-20: Structural development studies

I think that James Macdonald (Macdonald, J.) sums up the dilemma very eloquently of the architect, in his book 'Structural design for architects'. If this is the case when working with conventional construction and architectural design, many of the hurdles as stated get exponentially enhanced when working with the development of 'Deep Surface' as set out in chapter 3. Concurrently with the investigation of conceptual surface through the analogue generative process, the study of structure was engaged. Again the structural component of the deep surface entity had to be developed while conforming to the performance criteria as set out in section 5.2.1. Ideally the structure as with the surface would be a free form entity as generated in Generator B, however due to the constraints as set out in section 5.2.2, this was not feasible. Working with the restriction, flexibility and characteristics of structural steel, numerous structural systems were evaluated as part of the generative process. On the previous as well as this page the first attempts at the development of a suitable structure can be seen. On the following two pages the final conceptual development of the surface structure can be seen. In the technical chapter the structure is explained in greater depth.

Figures 6.22-25 Indicates the first experiments with a structural system composed of a diagrid lattice structure. The evaluation of a regular versus flattened grid.

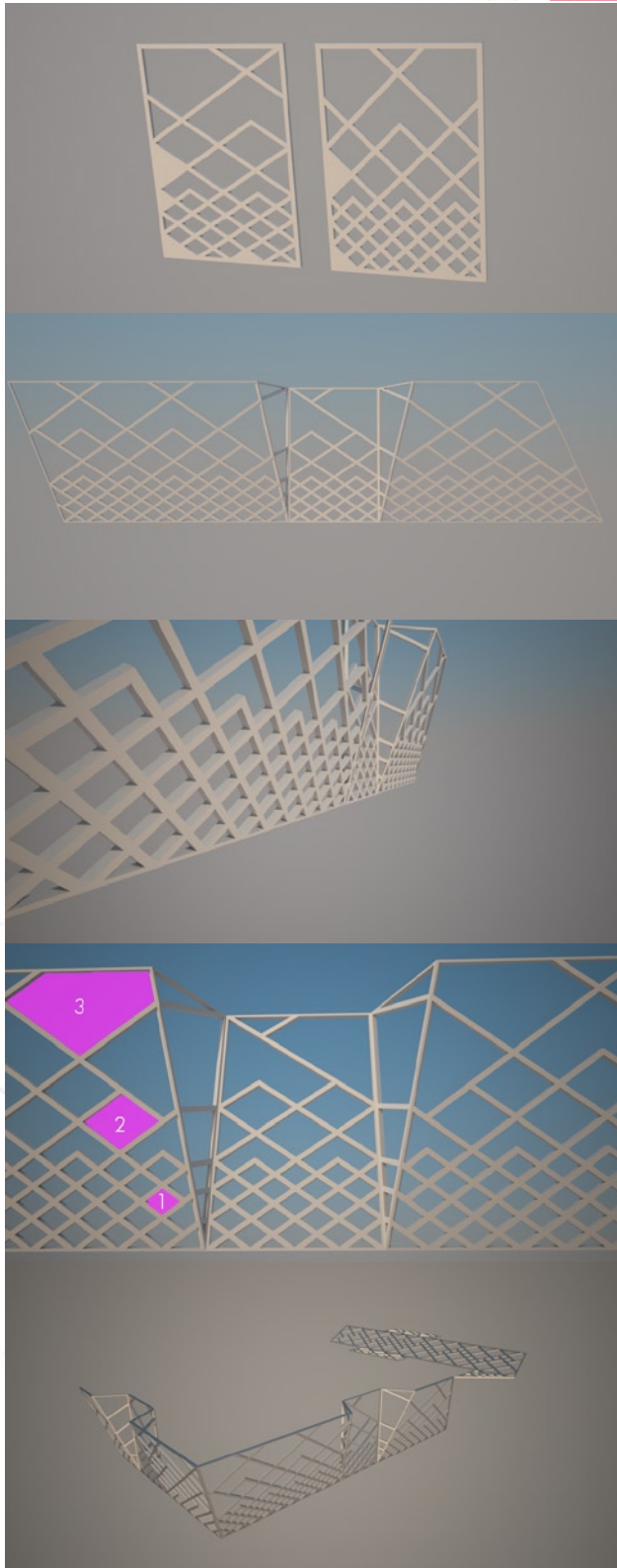

Figure 6.21-24: Structural development studies

The development of a three scale structural grid is evident from images 6.25 . This is yet another vital component in the final structural design of the surface.





The application of cladding elements in figures 6.26 - 28 shows an early developmental phase of what the final surface texture and pattern could become.

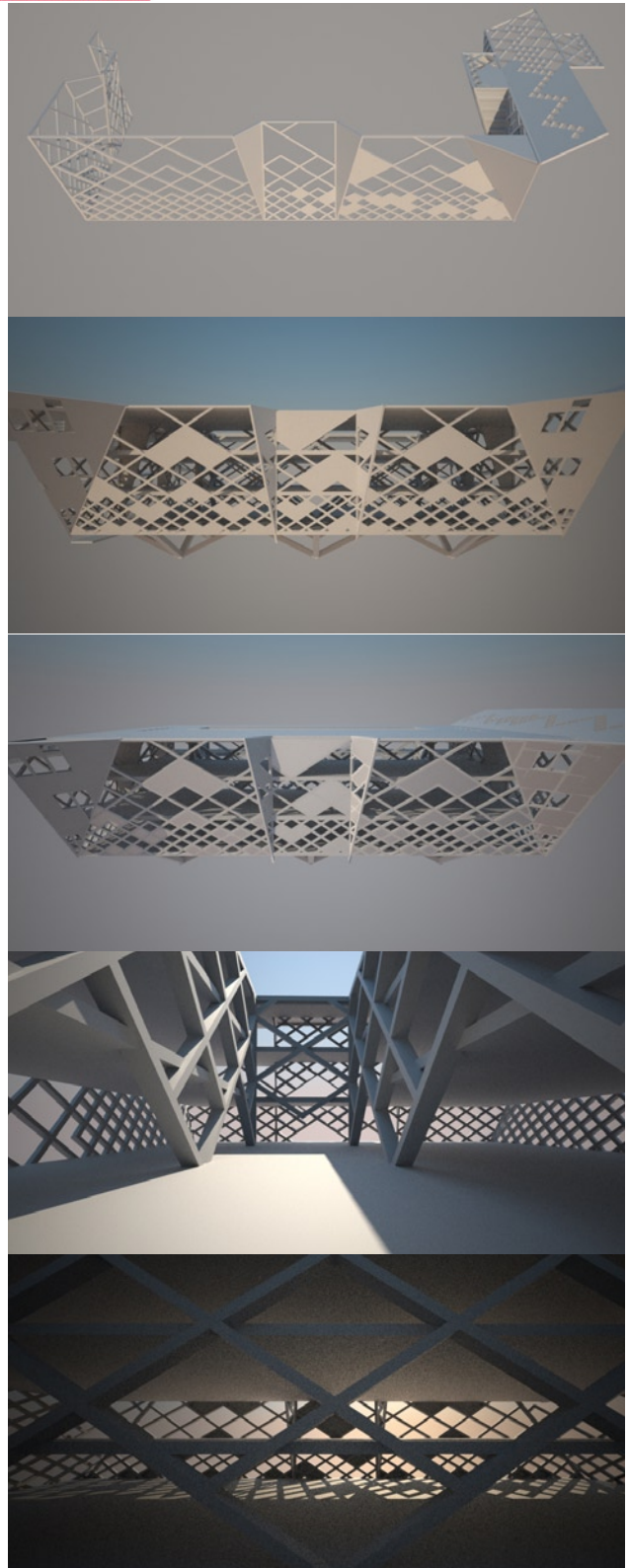

Figure 6.25-29: Structural development studies

The natural design development progression of a deep surface structural component can be seen in images 6.29 - 30 where the structure is folded inward to become the internal structural element.

6.2.4 Spatial Exploration

“Space constantly encompassing our being. Through the volume of space, we move see forms, hear sounds, feel breezes, smell the fragrances of a flower garden in bloom. Its visual form, its dimensions and scale, the quality of its light - all of these qualities depend on our perception of the spatial boundaries defined by elements of form. As space begins to be captured, enclosed, molded and organised by the elements of mass, architecture comes to being.”

The above quotation comes from Francis Ching’s `Form Space and Order and exploring spatial development in context of the `Deep Surface` theory was an interesting exploration of what is possible and achievable within the constraints of performance criteria. Figure 31 illustrates the first exploration in to the spatial aspect of deep surface, developing a contiguous entity that encompasses all the requirements of `Deep Surface`. Within the research facility certain specialised functional requirements for interaction and other technological requirements are needed. In the conceptual images below (32-41) the red cubes represent `Deep Surface` spatial elements and the yellow double volume break out spaces.

The conceptual development of the atrium and connection spaces focused on developing interesting, dynamic and exiting spaces. These spaces serve as the `community pubs`, places to meet and discuss, places of chance encounters, places where the occupants of the facility feel at home. In contrast to the `pub` analogy, these space also need to create exiting research spaces, hence they are all located in, above, across or linked to the central atrium structure and to all transition zone. The following images document the exploration of such spatial requirements.

Figure 6.30,31: Deep surface tubes spatial exploration

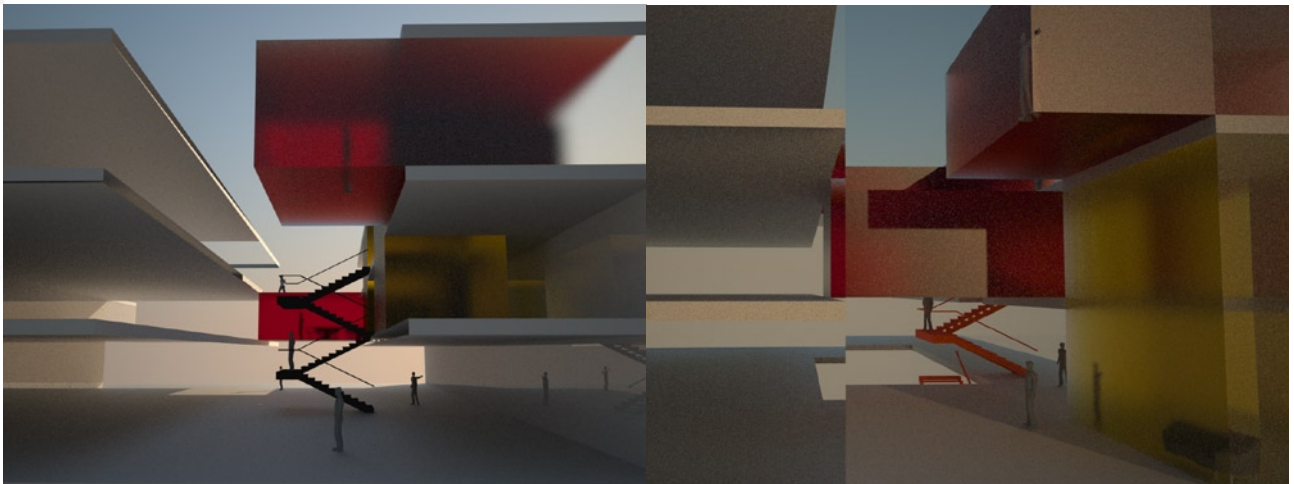

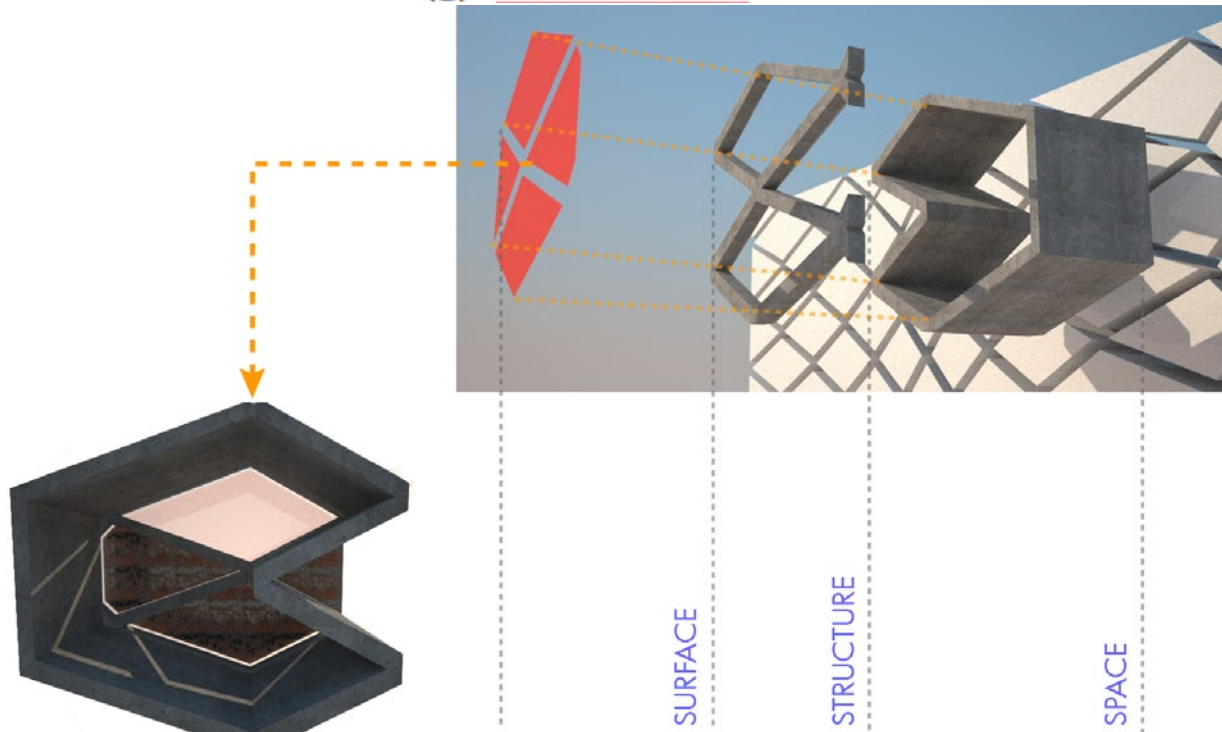
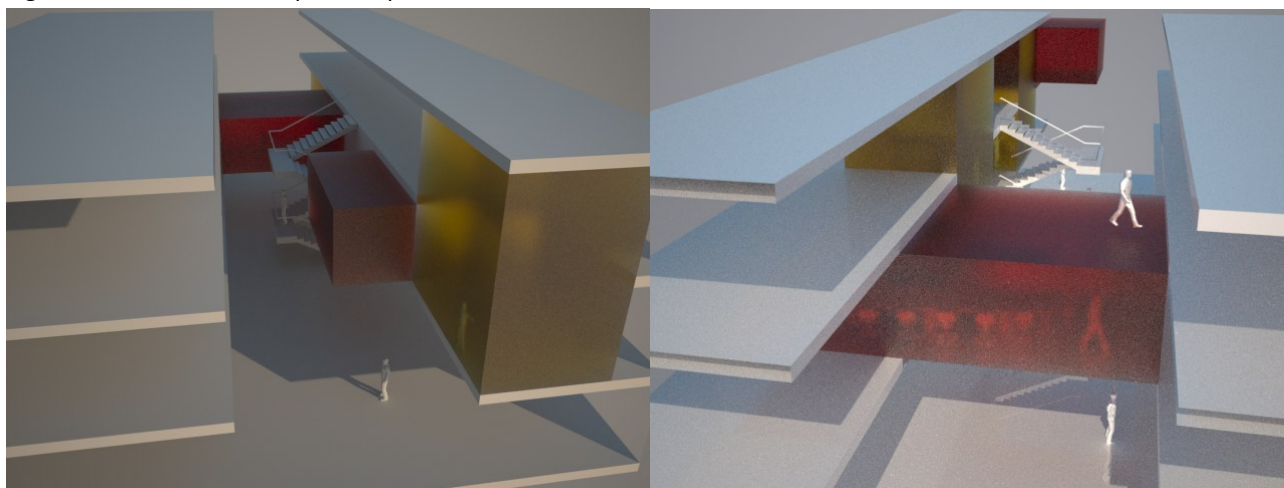

Figure 6.32: Initial conceptual rendering of Deep Surface

Figure 6.33,34: Break out spaces exploration



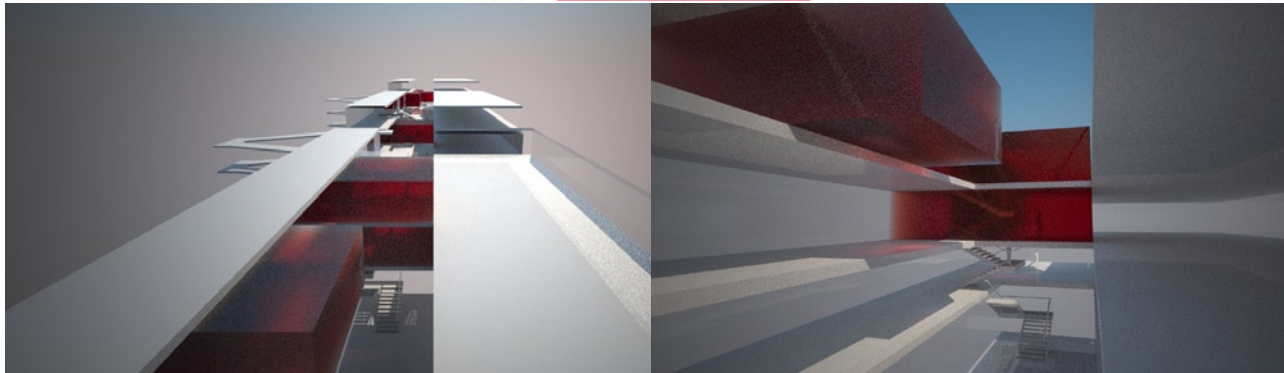
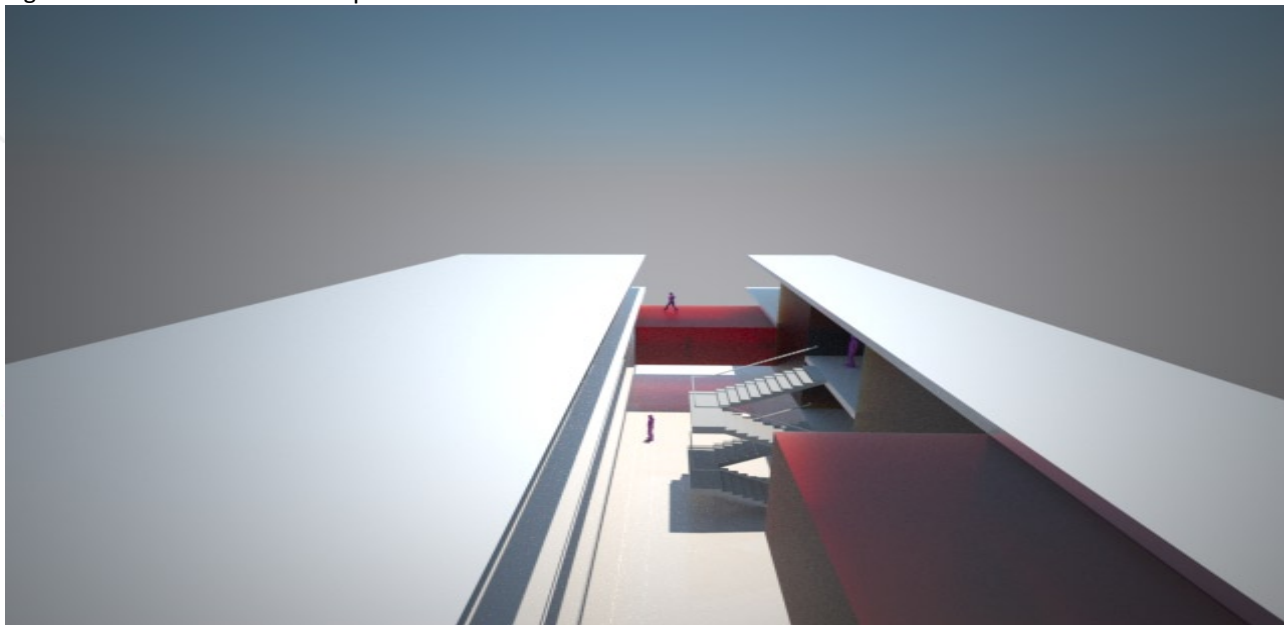

Figure 6.35,36: Conceptual spatial study of atrium



Figure 6.37: Aerial view of deep surface tubes



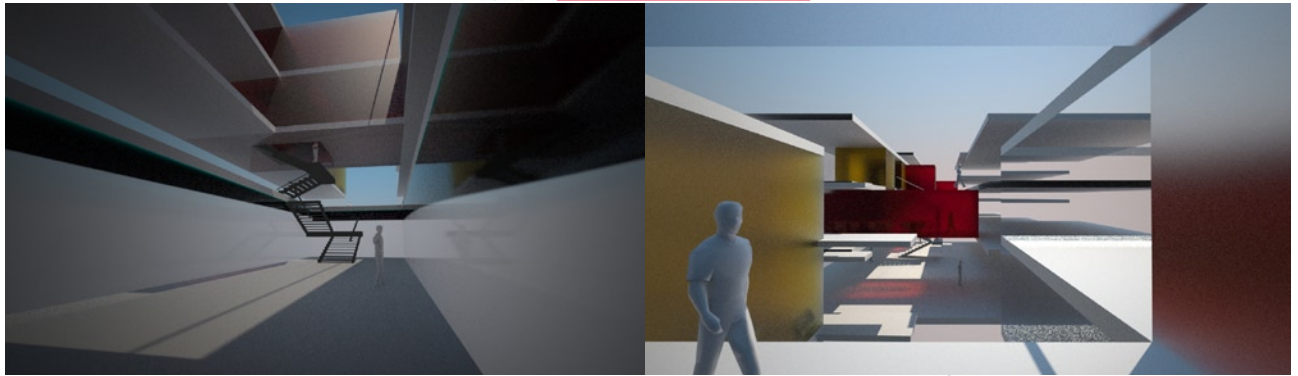

Figure 6.38,39: Deep Surface spatial study

Figure 6.40: View of quadruple volume atrium and spatial exploration



6.3 Form Development

“ Architectural form is the point of contact between mass and space ... Architectural forms, textures, materials, modulation of light and shade, colour all combined to inject a quality or spirit that articulates space. The quality of the architecture will be determined by the skill of the designer using and relating these elements, both in the interior spaces and in the spaces around buildings (Edmund N. Bacon, *The design of cities*, 1974).”

Francis Ching quotes Edmund Bacon in `Form Space and Order`, and as he notes; Form is a term that has several meanings....However it can roughly be defined by certain characteristics like shape, size, colour, texture, position, orientation and visual inertia.

Formal development in my research facility is informed by five main influencing factors; Views, Movement, Environmental restrictions, Theoretical approach and Facility planning. In this section I propose to cover only the first three indicators listed as the others are discussed in greater depth in other chapters.

6.3.1 Views

As one of the prominent contextual form development indicators views from and to the site building played a major part in its formal development. Views in and from a building defined the occupants spatial experience, they are tools that can be used as orientation devices, focal points or connections to the external environment.

Due to the traditional introverted nature of research and the contemporary performance criteria of providing external views to encourage innovative research, the facilities development focussed very strongly on external views, focal point and axis as a form giving indicator.

Figure 6.41: Conceptual view from deep surface

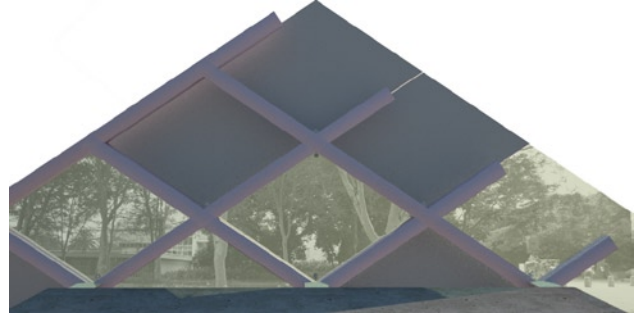

The formal exploration around views lead to the development of three distinct view orientated zones within the facility. Figure 6.50 - 53 shows the different zones. The zones can be identified as `Transitions Zones` where internal circulation, spatial and programmatic changes take place. Primary focal point views or `Atrium view Zones` that are also connected to transitions zone and the `Main Entrance` view point.

Figures 6.43 - 48 show main focal view points, transition zone views and possible entrance view frames.

In figure 6.49 the facilities massing in relation to its views indicators are show.

Another major influencing factor in the development of the facility was the connection between the Visual Arts building and the Music Department, in the original context, they are obscured from one another even though they belong to the same precinct. This led to a strategy of elevating the building in a terrace style, to clear all visual impediments and give these two iconic building the visual link and recognition that they deserve.

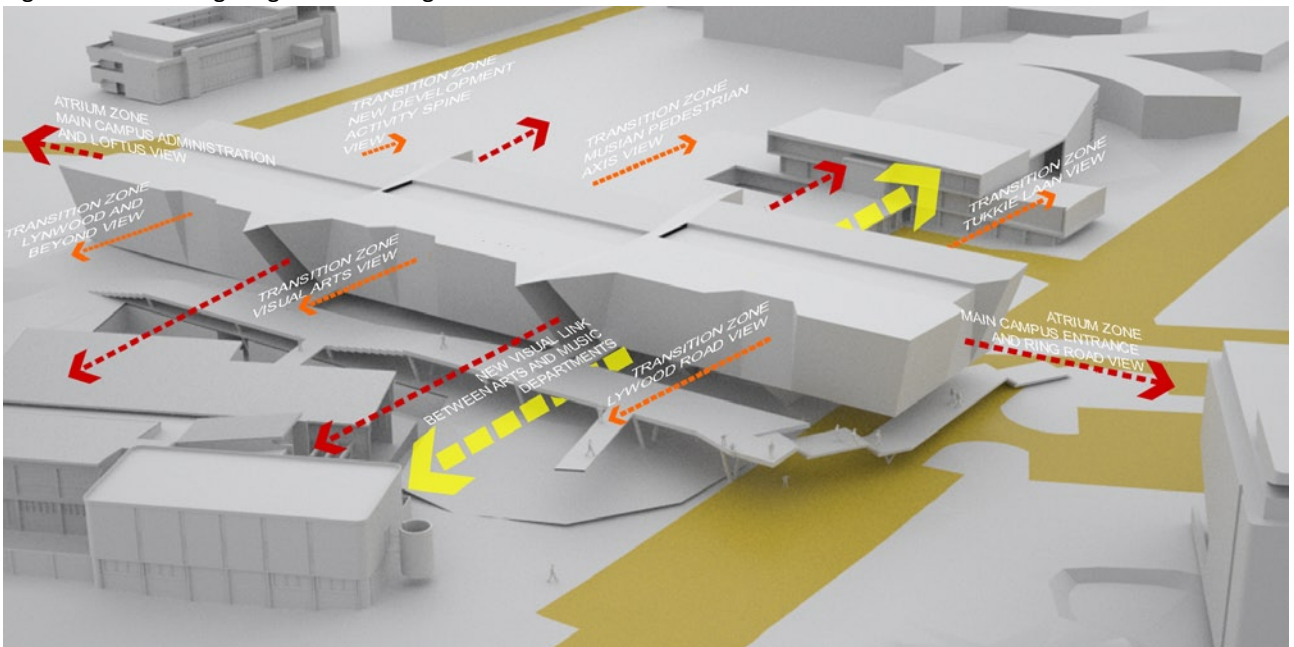

Figure 6.42-44: Focal point views as part of formal development

Figure 6.45-47: Focal point views as part of formal development



Figure 6.48: Massing Diagram Indicating main views and axis



FORM DEVELOPMENT

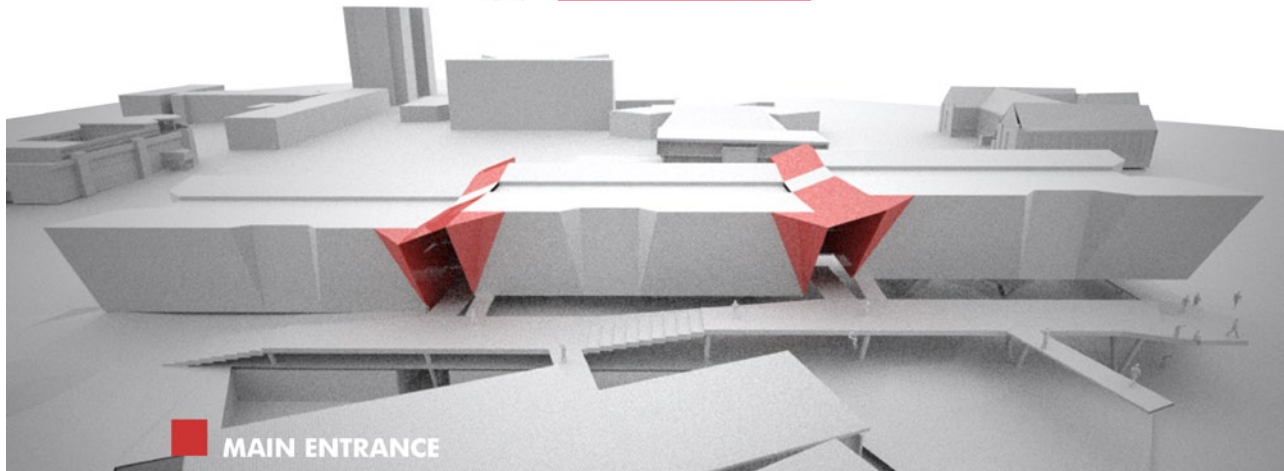

Figure 6.49: Conceptual massing diagram indicating main entrances

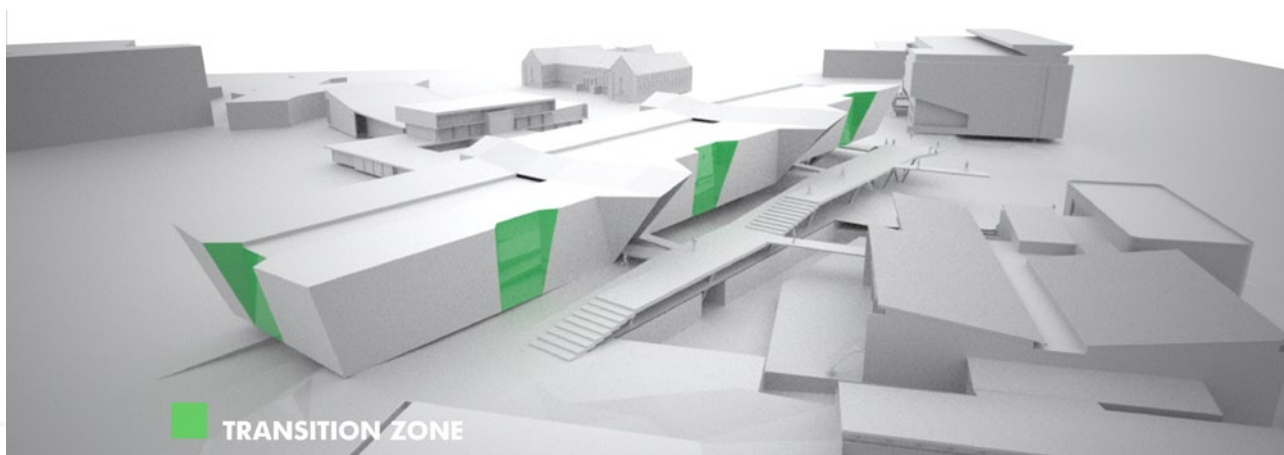
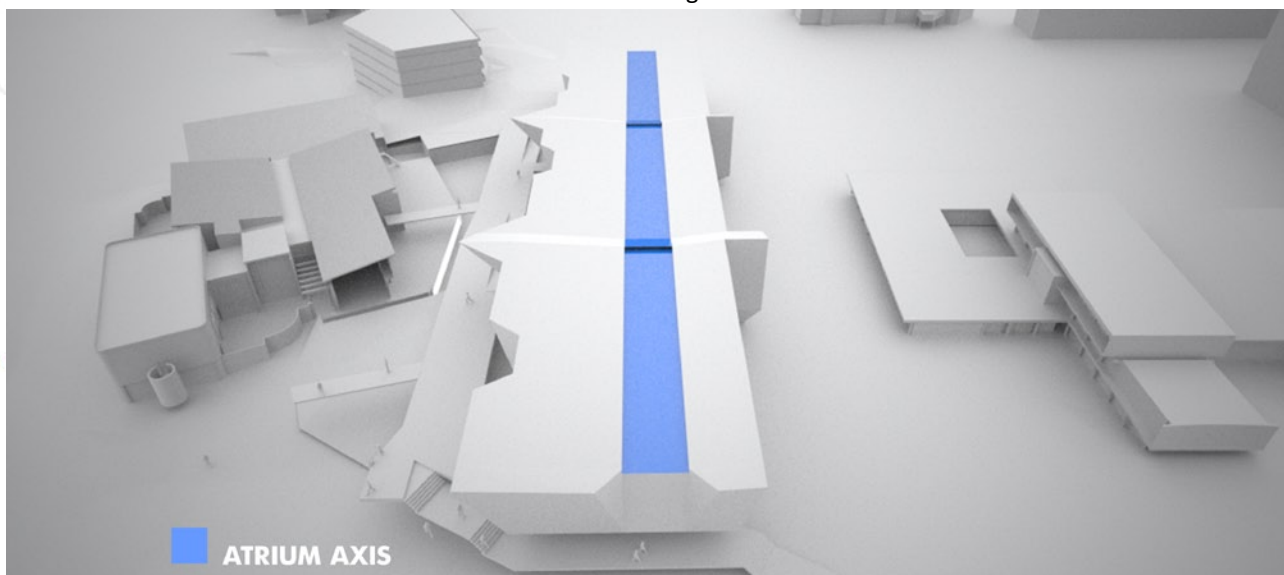

Figure 6.50: Transition Zones

Figure 6.51: Connective atrium axis



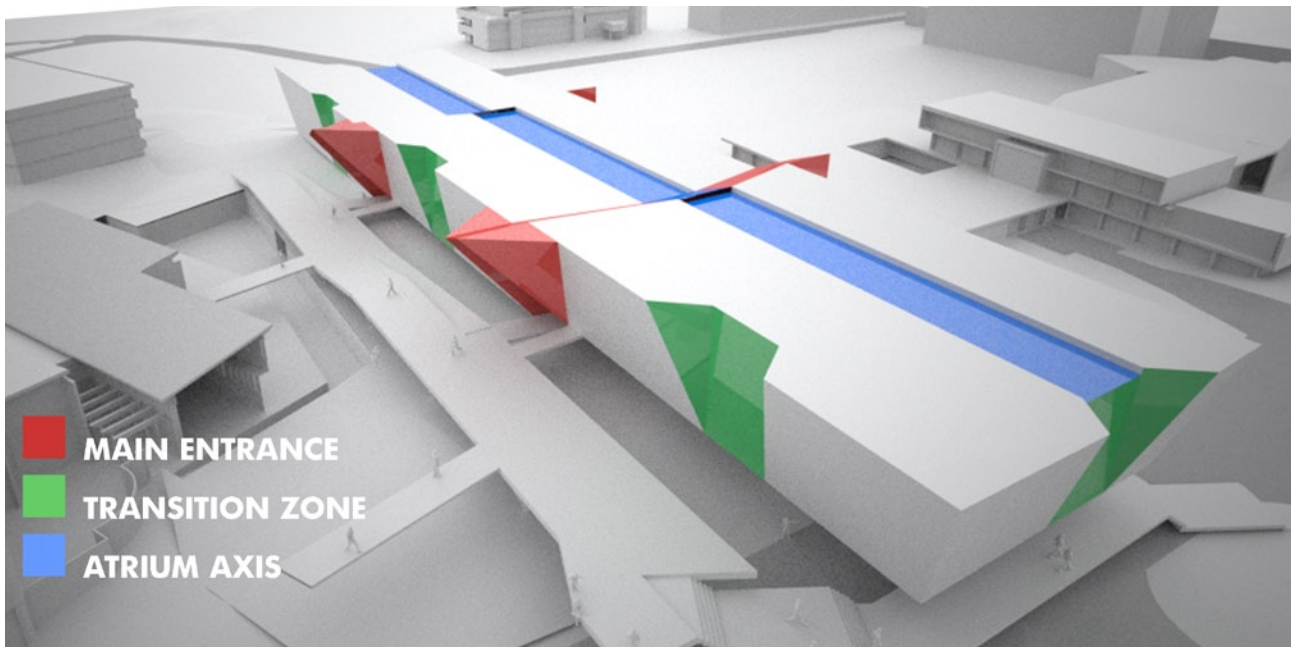

Figure 6.52: Combination of view determined formal development



6.3.2 Circulation

As one of the major form, activity and vitality defining indicators present on a site, the circulation needs to be considered very carefully. As stated by Ching, the path of our movement can be conceived as the perceptual threads that links the spaces of a building or any series of internal or exterior spaces together.

“ Since we move in **Time** through a **Sequence of Spaces...** “

A further study of Chings approach to circulation and movement one identifies the following key parameters involved when designing circulation through space.

- A. Approach
- B. Entrance
- C. Path-space relationships

A number of performance criteria were of critical importance parallel to Chings concern when looking at the development of the external spatial circulation system.

1. The establishment of a new precinct connection between arts and research
2. The locality of the major ringroad and tukkies laan intersection
3. Dealing with a corner site appropriately
4. Forming the circulation as part of a spatial extension of the surface of the facility.

In figures 6.54 - 58 the development of the external circulation system can be seen. From initial conception to final design the system made use of the design indicators as listed above, thus the evolution of the design to the most appropriate solution as shown in figure 6.59 .

Facilitating inter precinct, inter disciplinary and inter-ractional circulation, communication and connection is the main aim of the raised circulation walkway.

Due to the corner nature of the site it was difficult to determine a suitable main entrance for such a large facility. Together with the parameters of focal view points, creating three independent yet integrated research units, facilitating environmental awareness the development of two main entrances as is seen in figure 50 was inevitable. Figure 6.60 shows the sketch exploration of the above mentioned concept. In these two main entrances the walkway enter in to the main entrances and pass through the facility in to the horizontal/awareness circulation zone.

The walkway also proposes to connect on the first floor level to the Visual Arts department and the proposed new addition to the visual arts facility. This will facilitate the walkway as being the connective tissue between the arts and research precincts.

The last important factor is the walkway is designed path-space specific interaction zones, allowing the walkway to become an outdoor extension of the research environment, with spaces and places to pause, discuss and interact. In fact becoming a social space in its own right, a mirror of the internal atrium street connecting the research facilities, the walkway is the exterior communal connective street.





First conceptual exploration of circulation system as free form connective tissue like substance, morphing and adapting to its functional and spatial requirements.

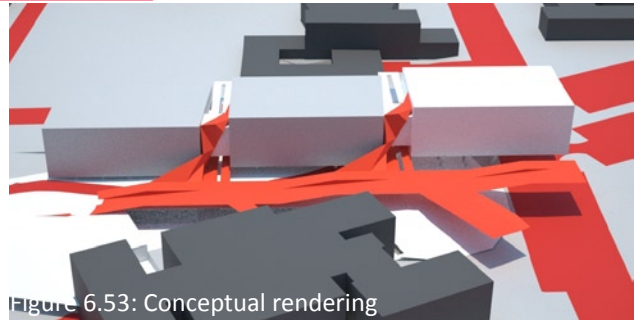

Figure 6.53: Conceptual rendering

First conceptual exploration viewing the walkway as light emitting entity.

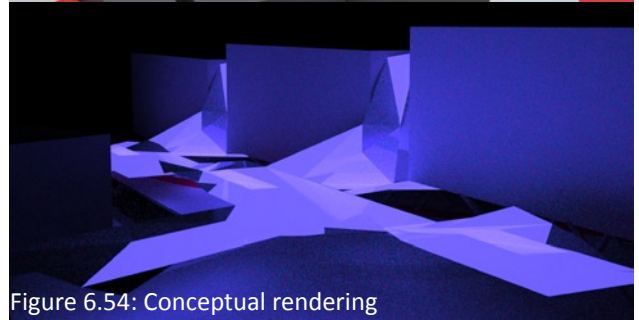

Figure 6.54: Conceptual rendering

Further exploration of walkway surface connecting from main boukunde entrance and spanning across the tukkie laan pedestrian entrance.



Figure 6.55: Walkway from boukunde

Exploration of circulation surface in recognition of the major movement intersection at the main campus ringroad.

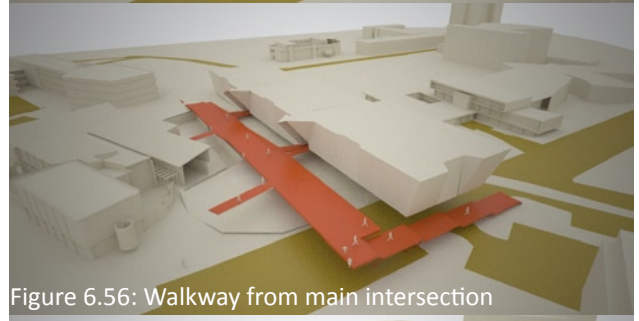

Figure 6.56: Walkway from main intersection

Development of circulation taking in to account the path-space relationship of Ching, the experience of pedestrians while moving from open space to below the facility and open space again, while moving parallel to the main ground level pedestrian network. The development strives to create and facilitate environmental and spatial awareness.

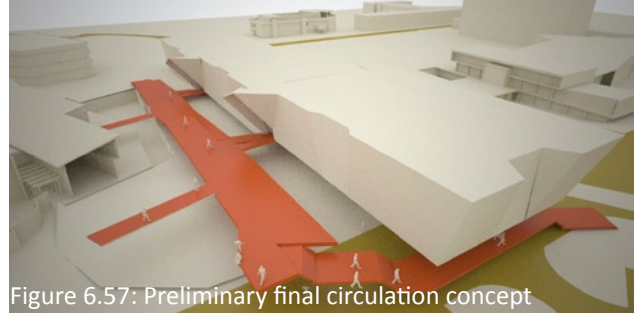

Figure 6.57: Preliminary final circulation concept

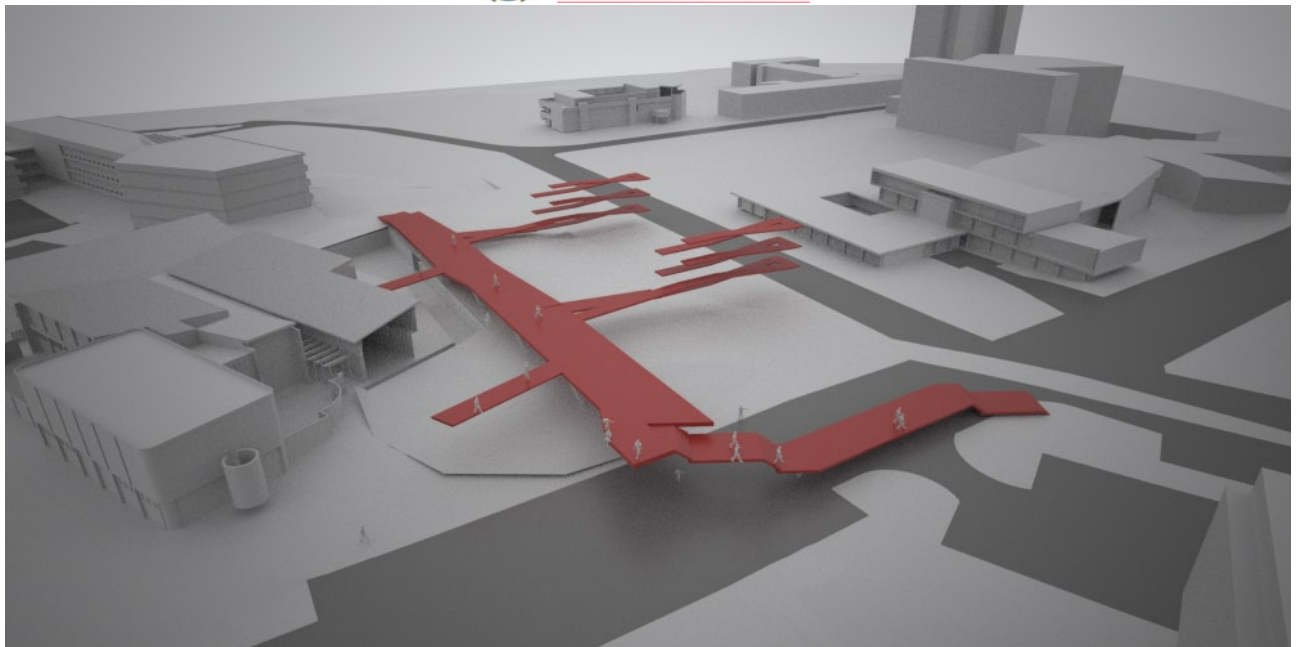
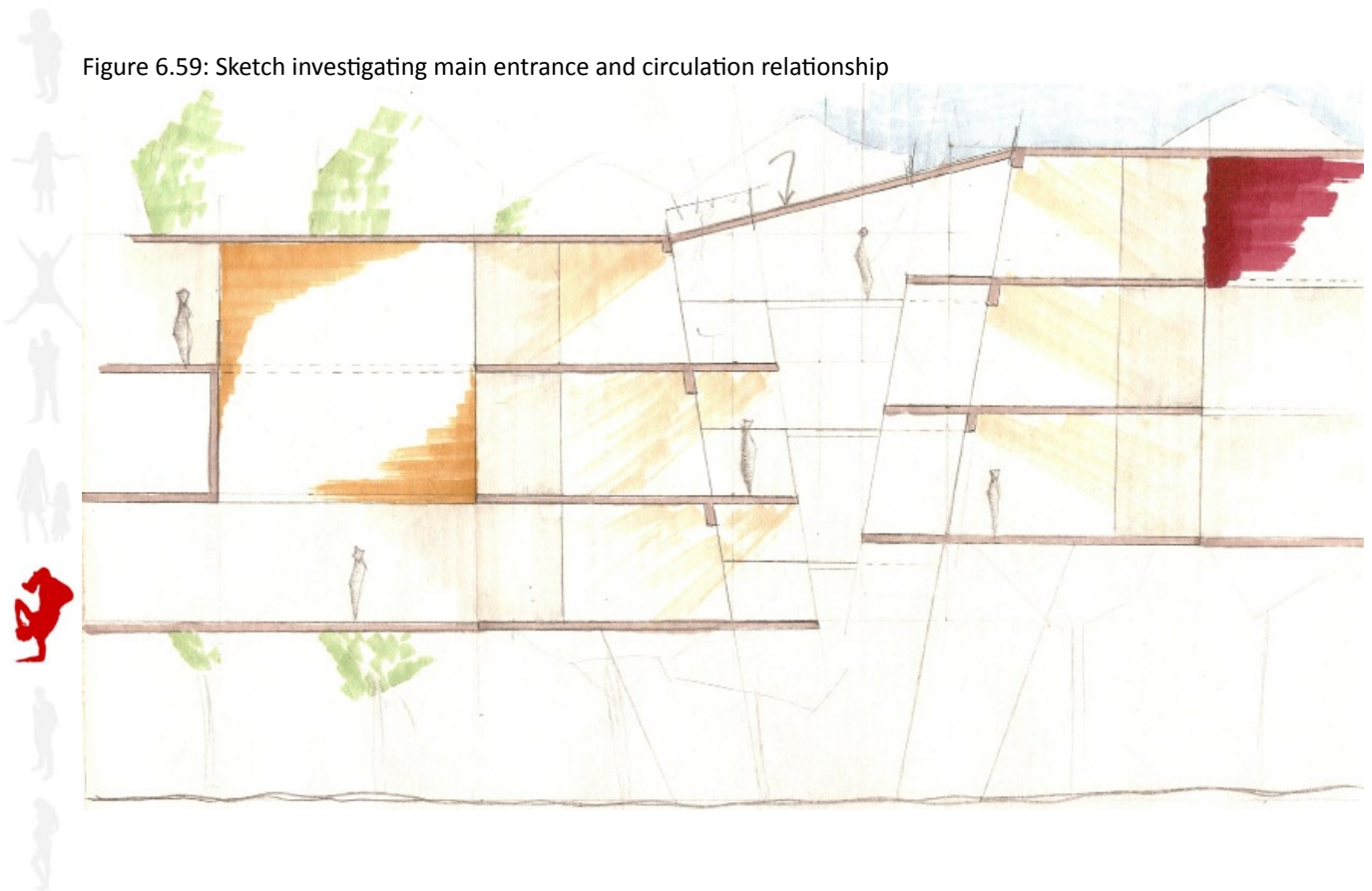

Figure 6.58: Final Conceptual model of circulation system

Figure 6.59: Sketch investigating main entrance and circulation relationship





6.4 Intervention

The following section contains numerous parts that represent the proposed research facility for the University of Pretoria.

Artistic impressionis of one of the proposed connective atrium spaces are represented in section 6.4.1.

Section 6.4.2 contains the technical drawings that define the detailing construction and planning of the facility

The final contextual three dimensional representation of the facility are contained in section 6.4.3.

6.4.1 3D Atrium Views

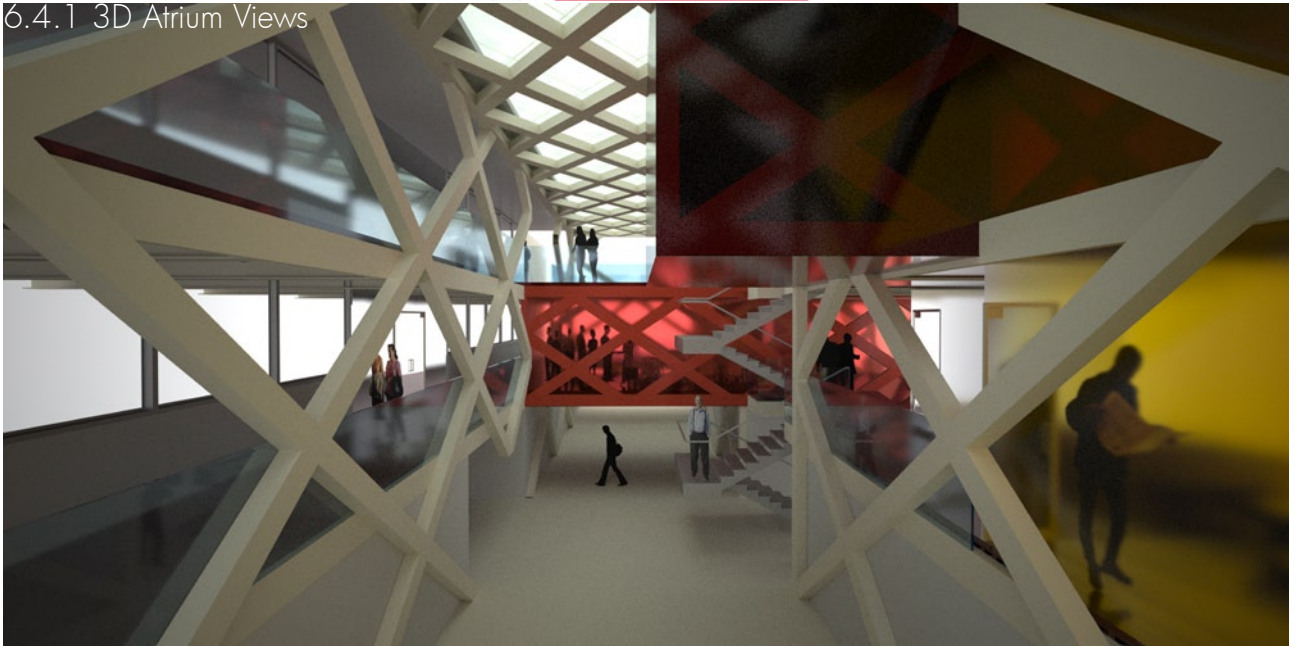
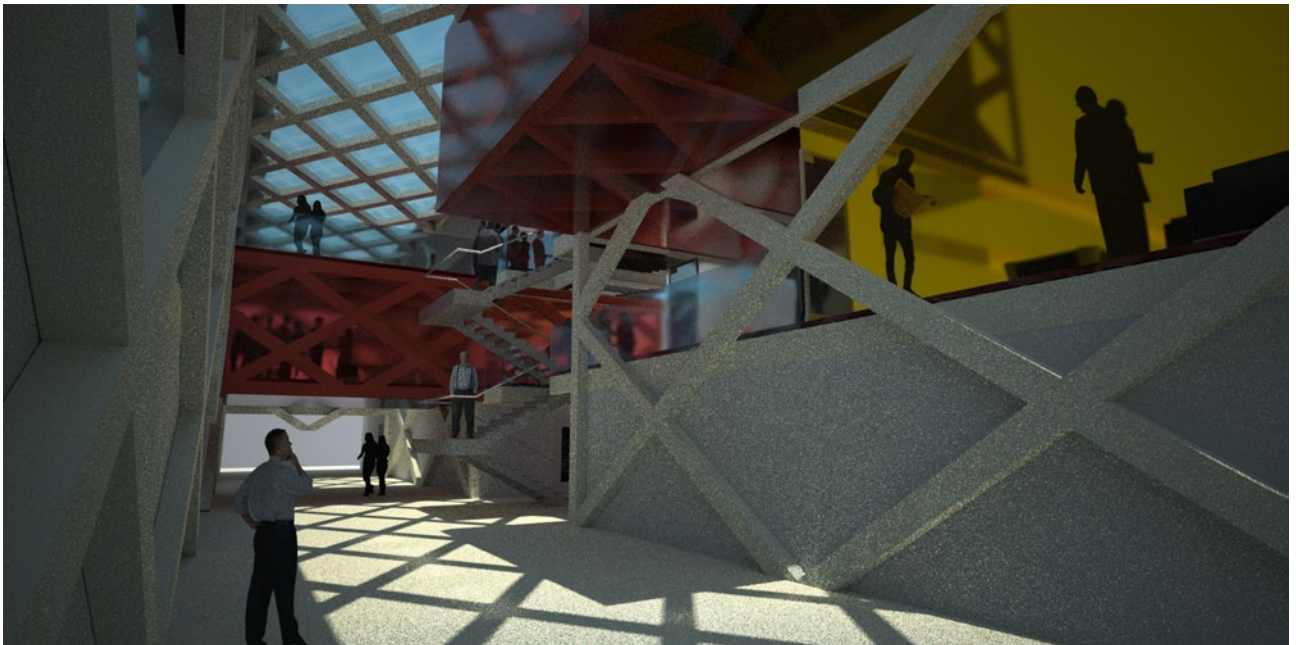

Figure 6.60: Perspective artistic impression of one of the proposed atrium zone with all its connective and interactional devices. The proposed tubes (red) and break out space (double volume, yellow) can be clearly seen.

Figure 6.61: Perspective artistic impression of one the proposed atrium zone showing the vertical link between structure and space in the atrium zones, as well as daylight penetration at midday in the summer.



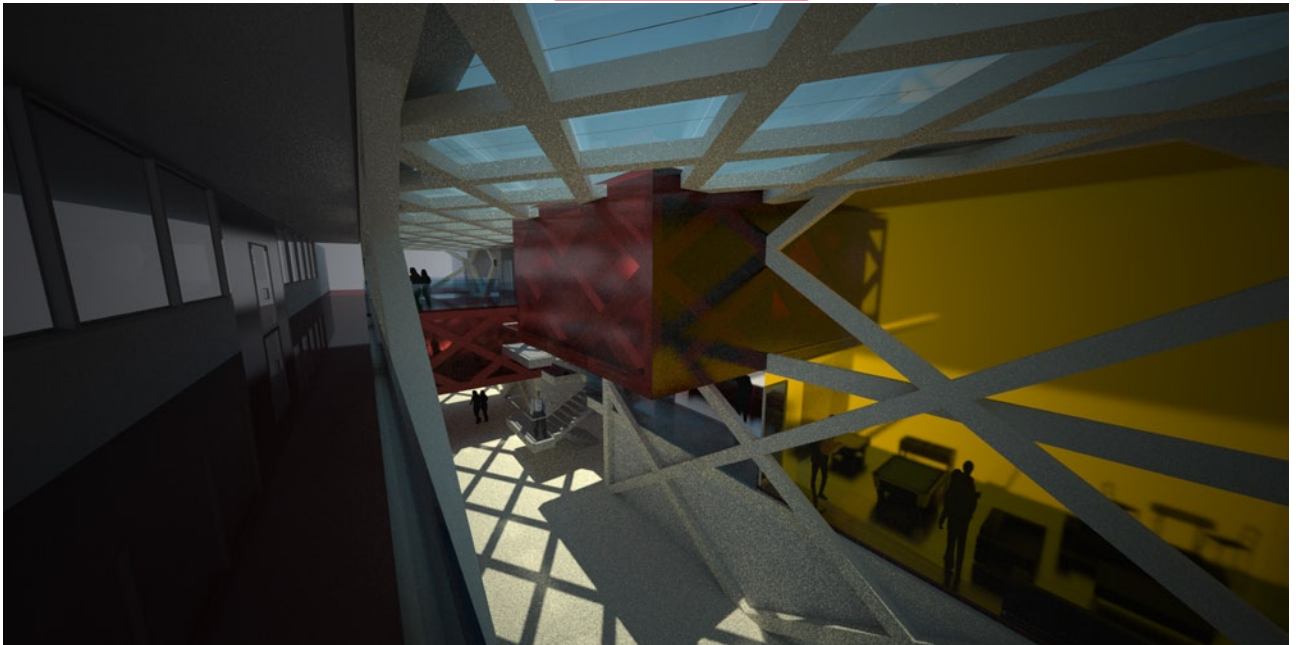
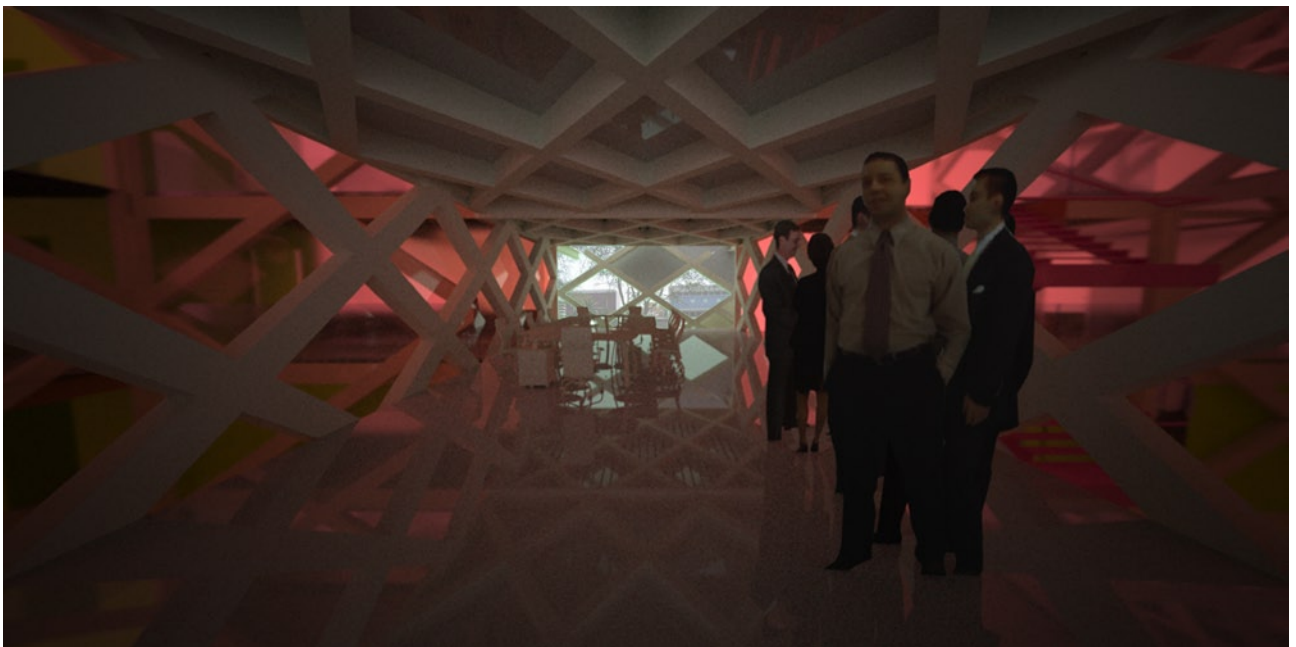

Figure 6.62: Perspective artistic impression of one of the proposed atrium zones from the upper laboratory circulations space. The full extent of the double volume break out spaces can be seen from this vantage point.

Figure 6.63: Perspective artistic impression illustrating the interior of the long connective tube, the flexible interior can be subdivided in to small conference facilities or used as a big open exhibition or conference space.



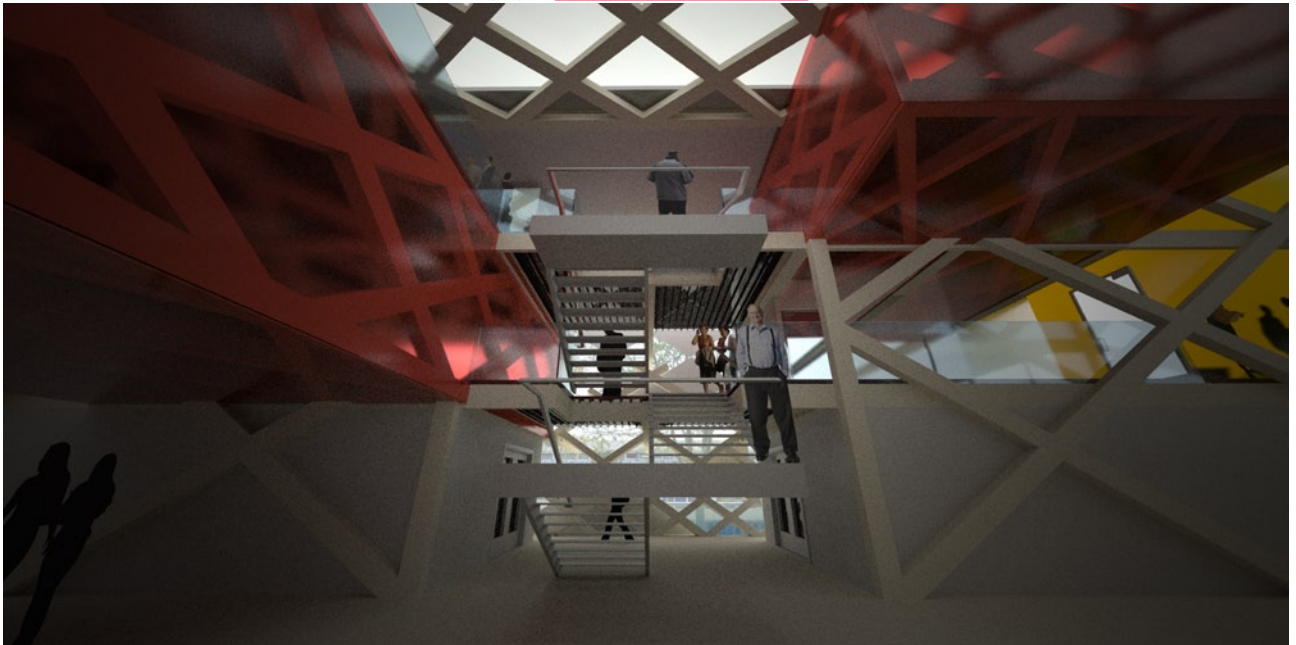
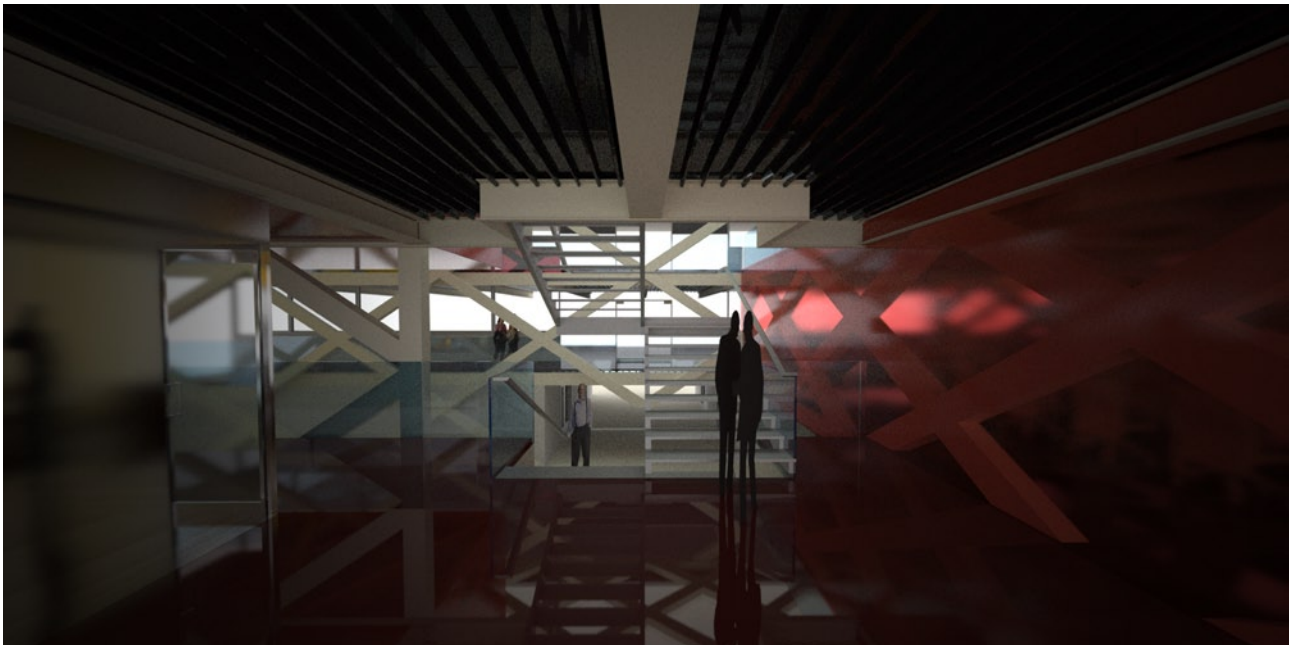

Figure 6.64: Perspective artistic impression illustrating the view of the transitions zone with vertical circulation in the atrium.

Figure 6.65: Perspective artistic impression from the proposed transition zone at second floor level in to the atrium.



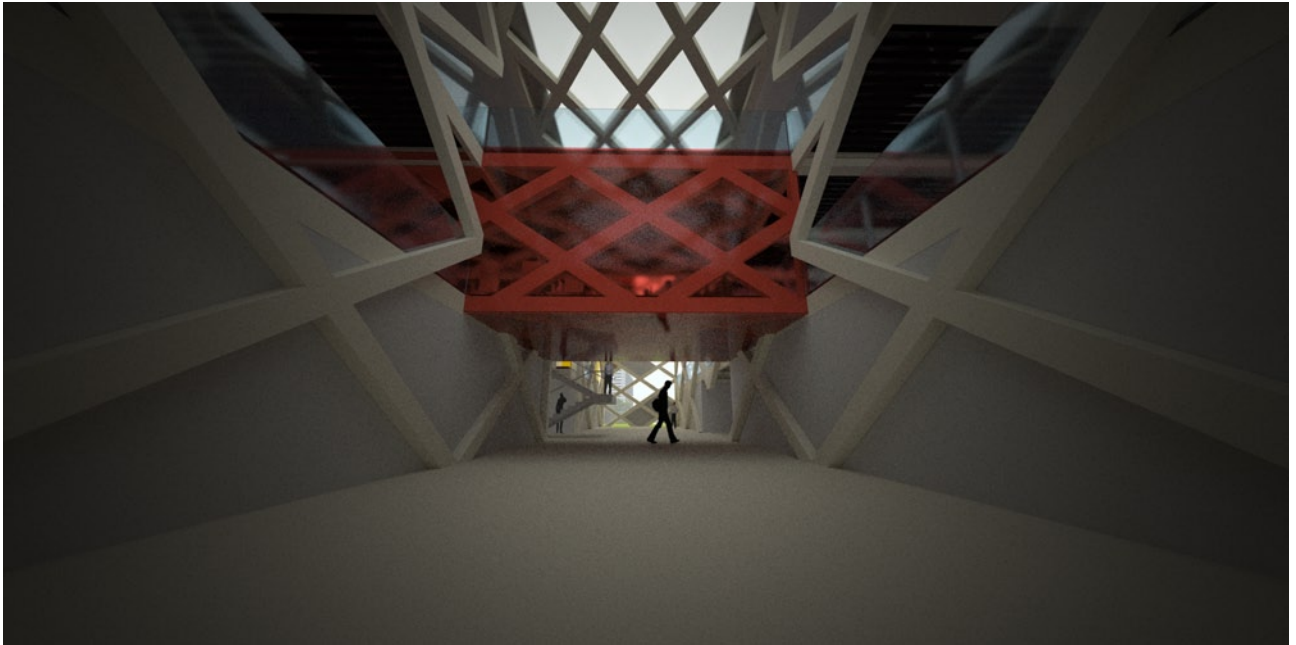
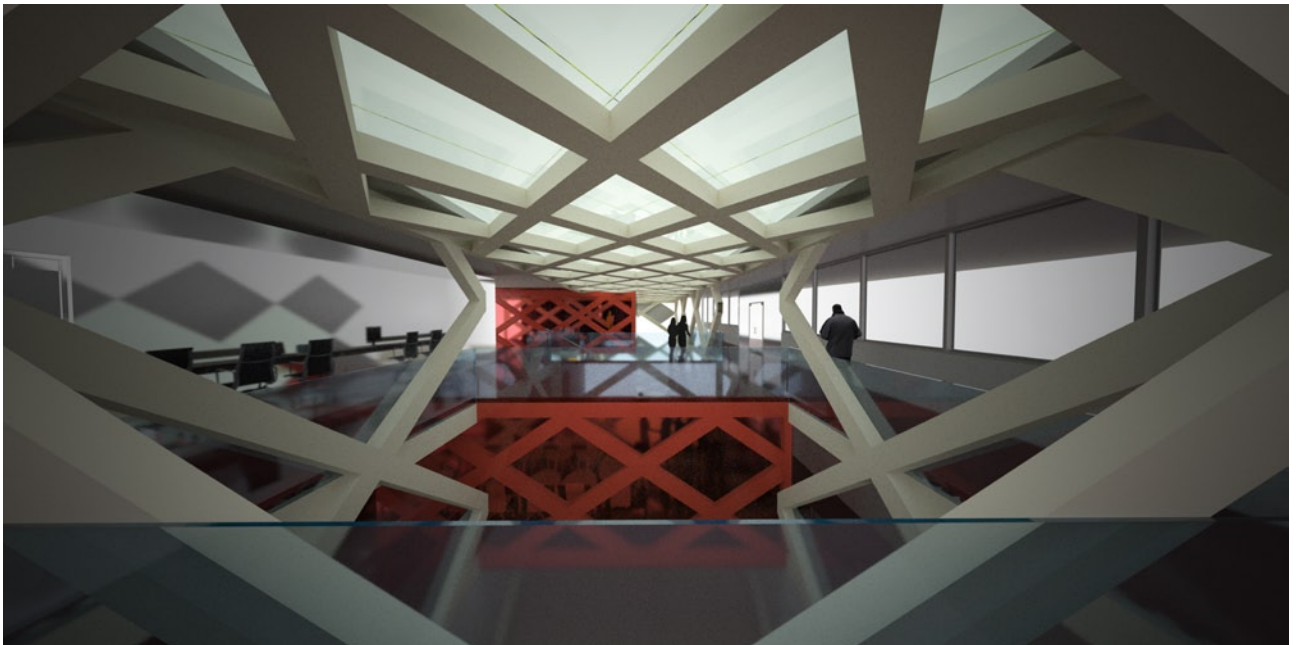

Figure 6.66: Perspective artistic impression illustrating the view of the atrium as it will be experienced when entering the research unit at first floor level.

Figure 6.67: Perspective artistic impression illustrating the view of the atrium as it will be experienced when entering the research unit at third floor level. One post graduate research units can be seen to the left as well as the penetrating tube acting as horizontal circulation.





6.4.2 Technical Drawings

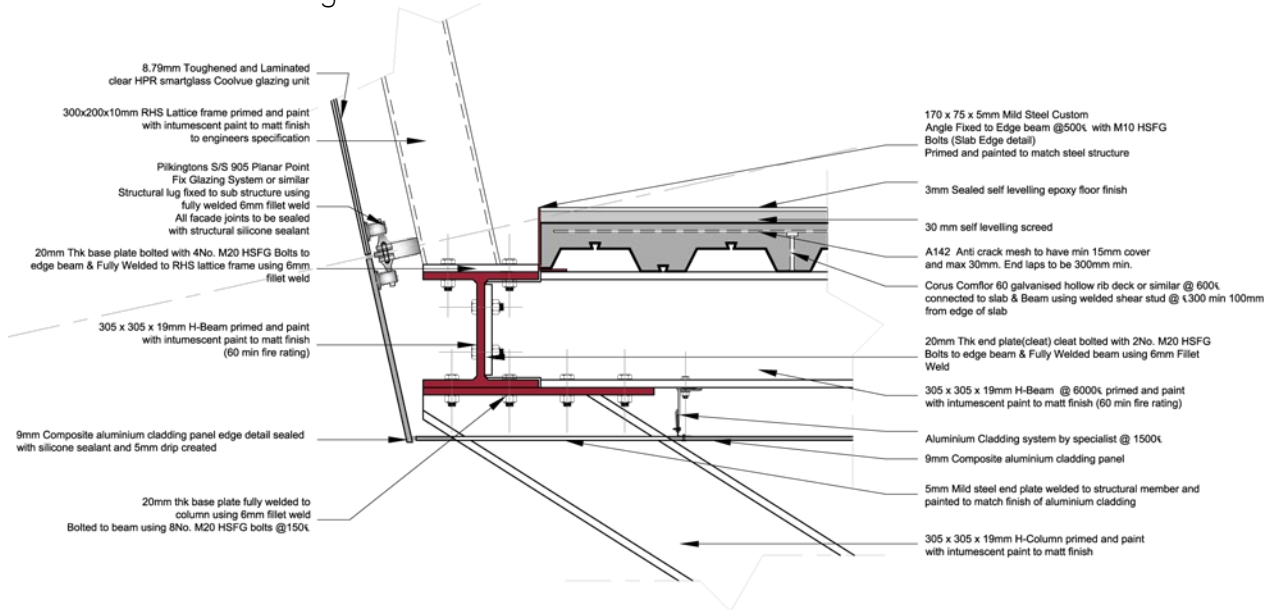

Detail A - 1:20 - Primary base support structure

Detail B - 1:20 - Floor and surface intersection

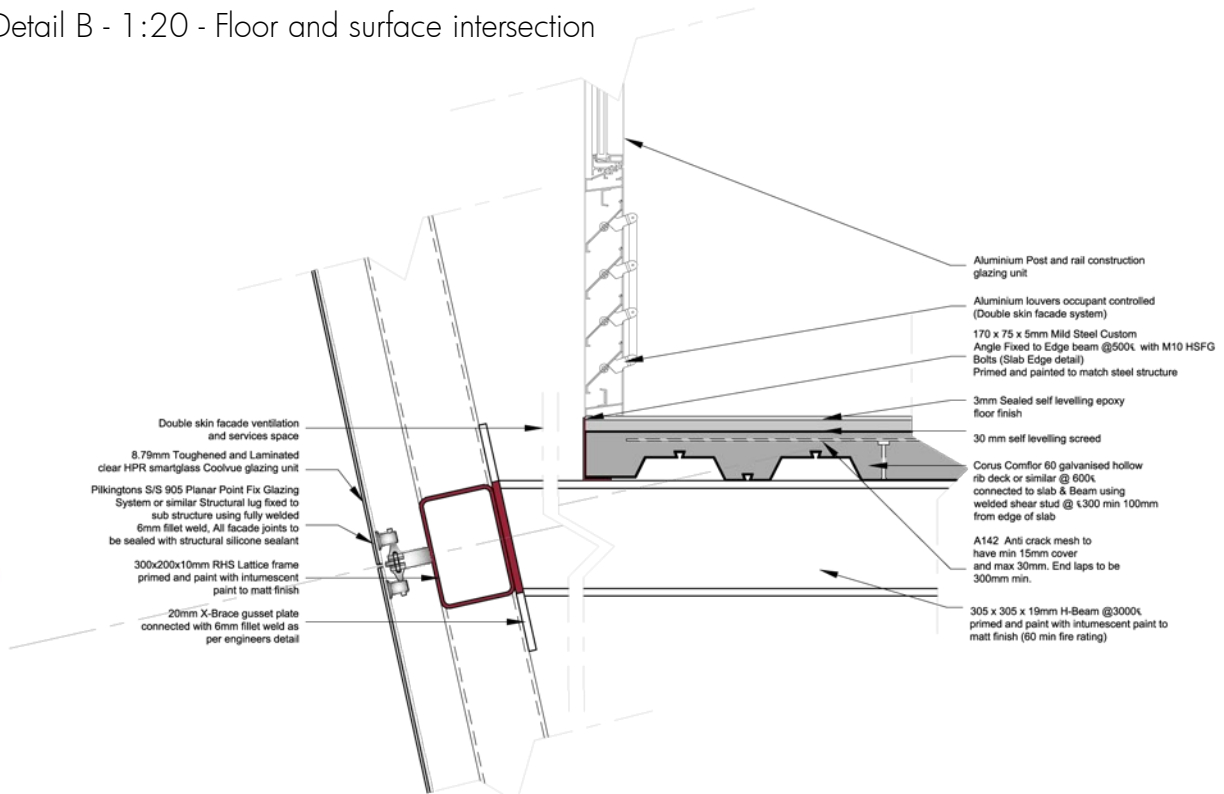

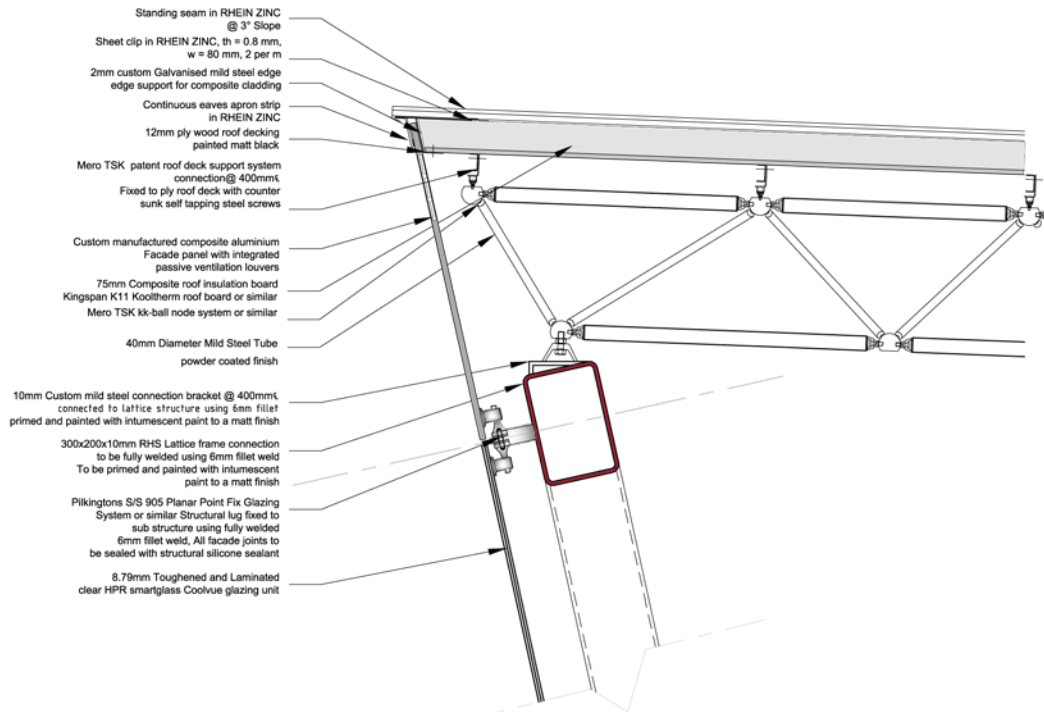

Detail C - 1:20 - Roof and envelope intersection

Detail D - 1:20 - Atrium glazing and drainage

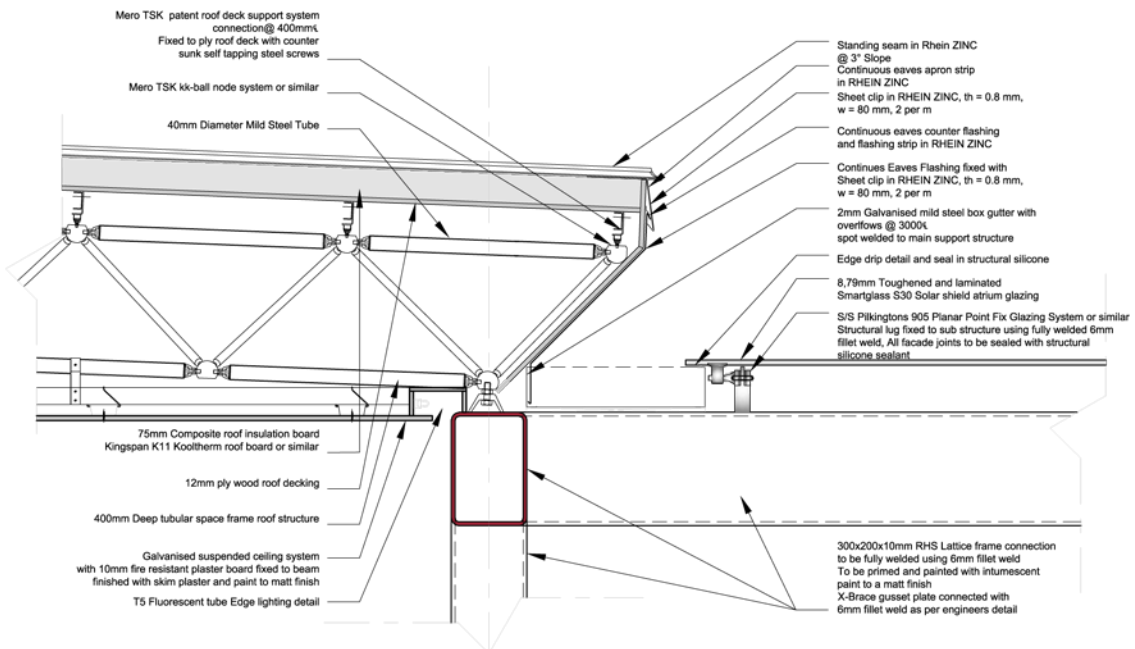

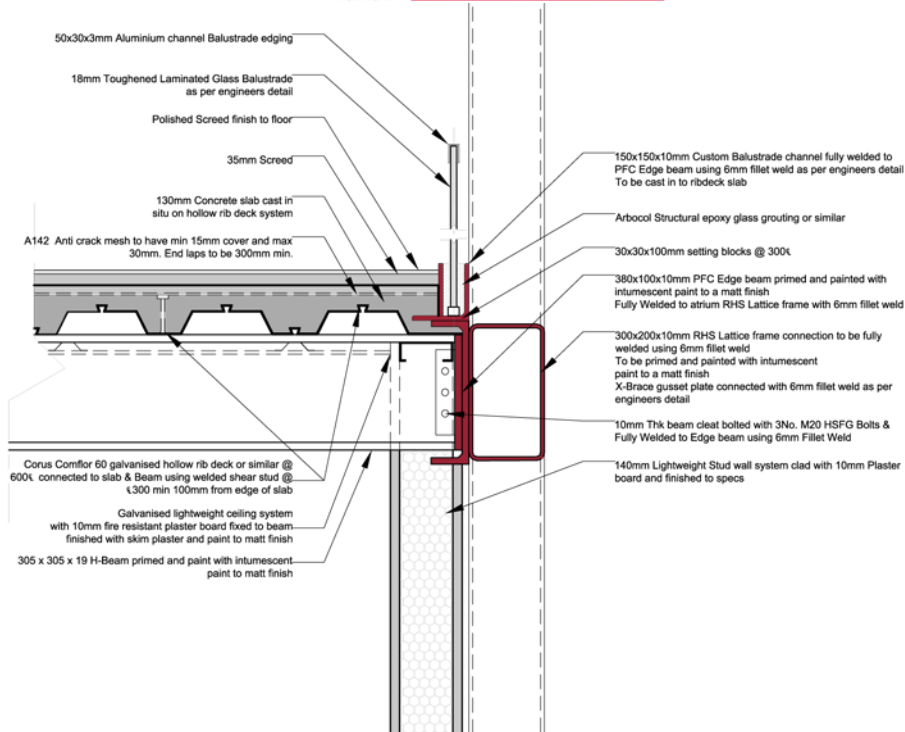

Detail E - 1:20 - Atrium lattice floor intersection

Detail G - 1:20 - Green roof parapet and balustrade detail

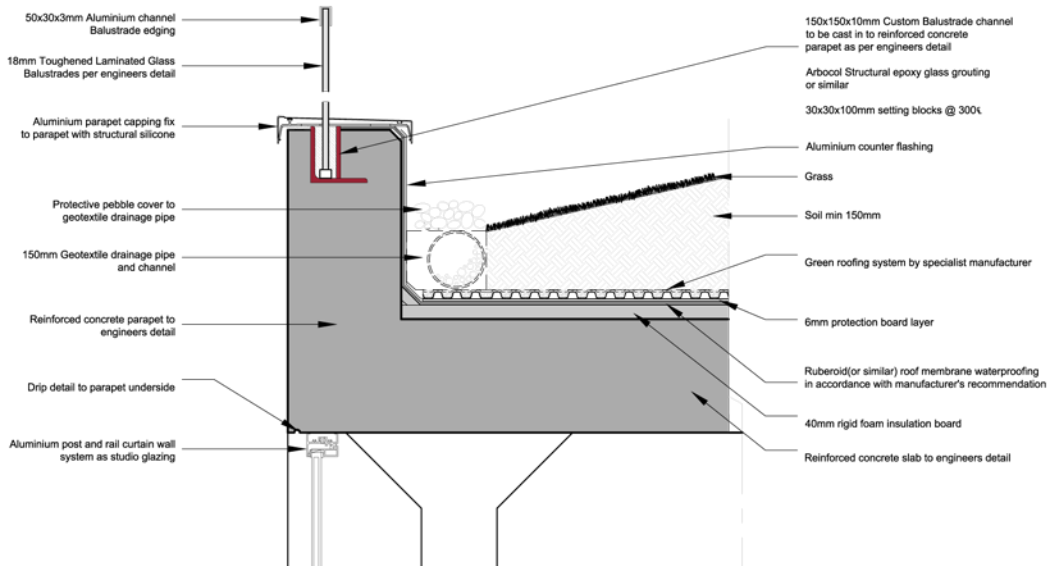

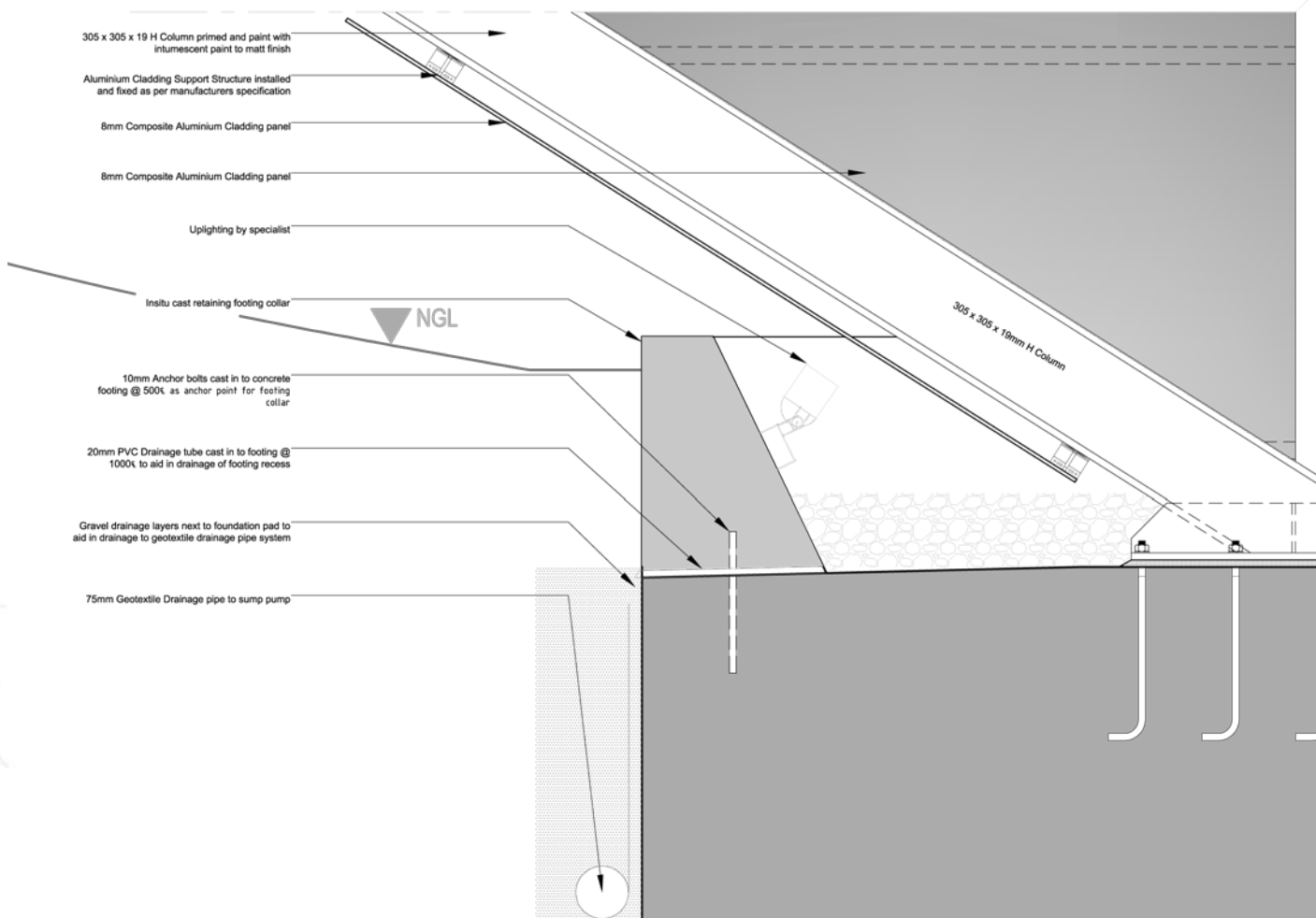

Detail F - 1:20 - Foundation assembly and connections

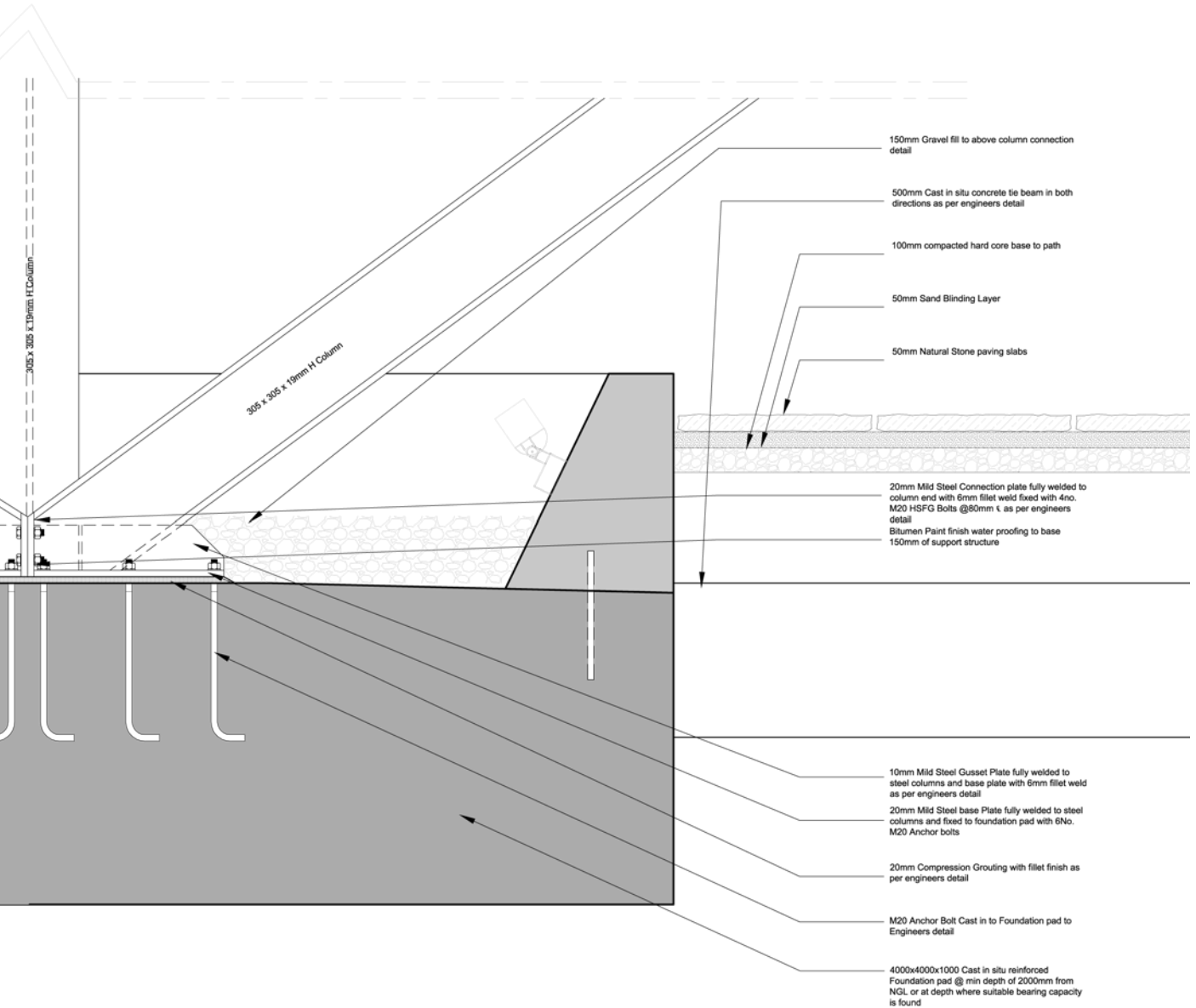

6.4.3 3D Contextual Renderings

Isometric Context Rendering

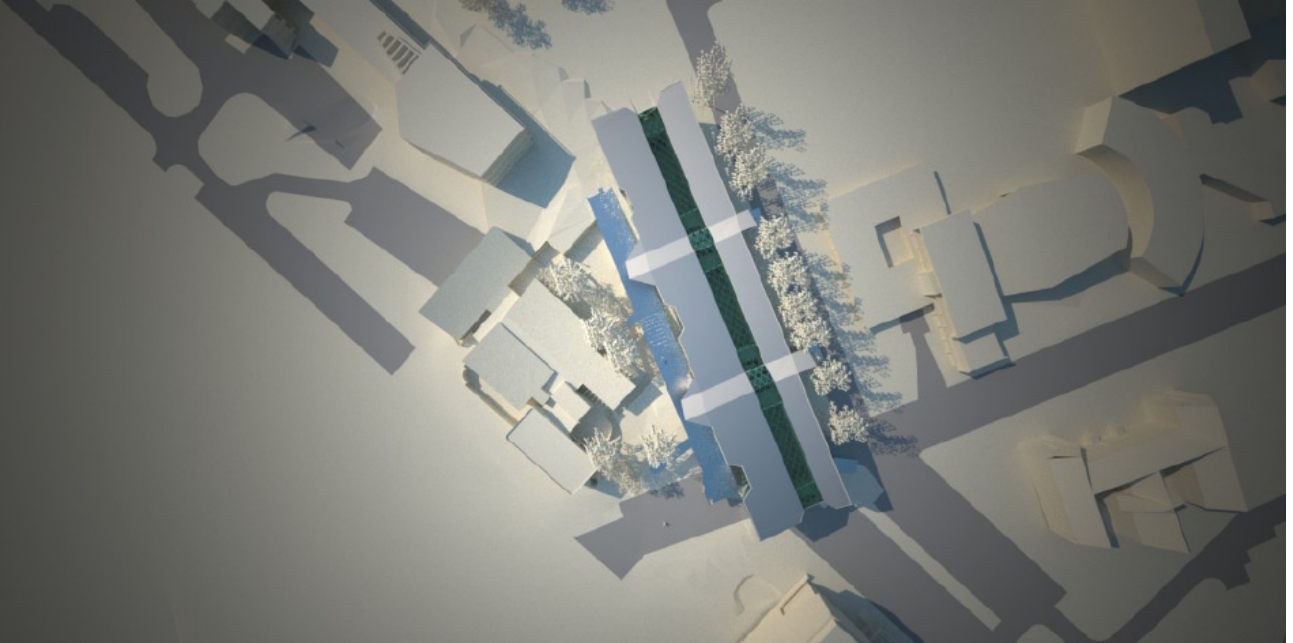
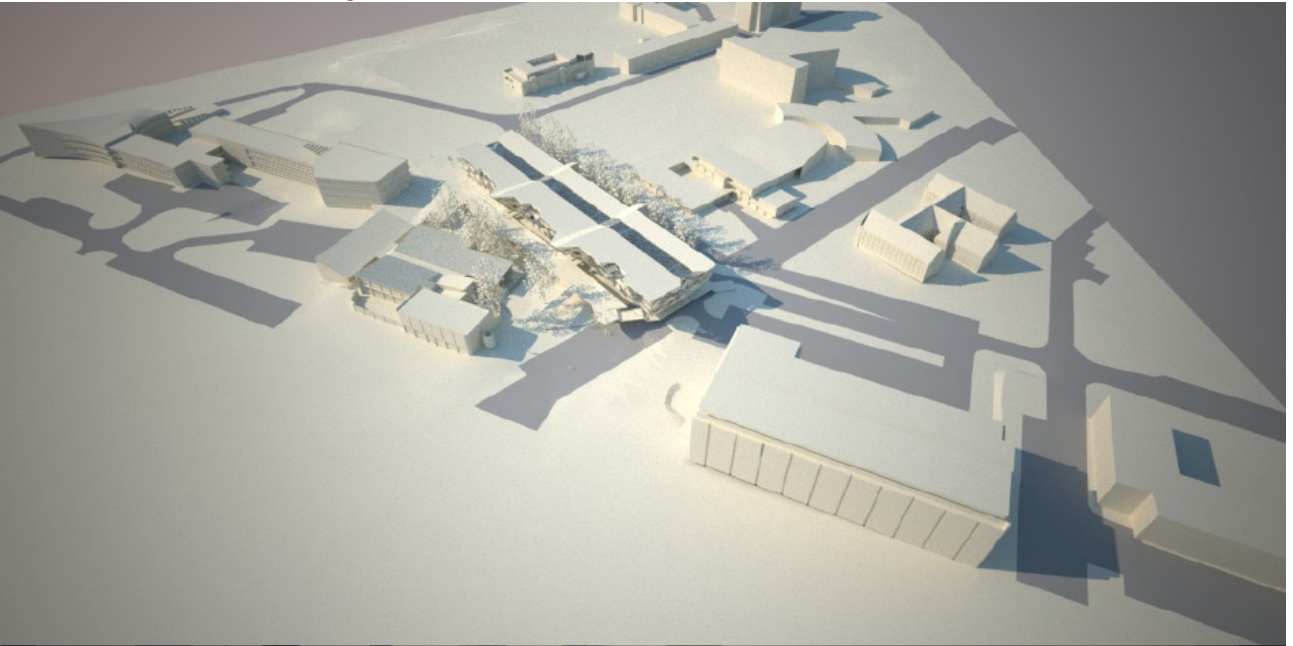

Birds Eye View Rendering



Tukkie Laan Entrance Isometric View

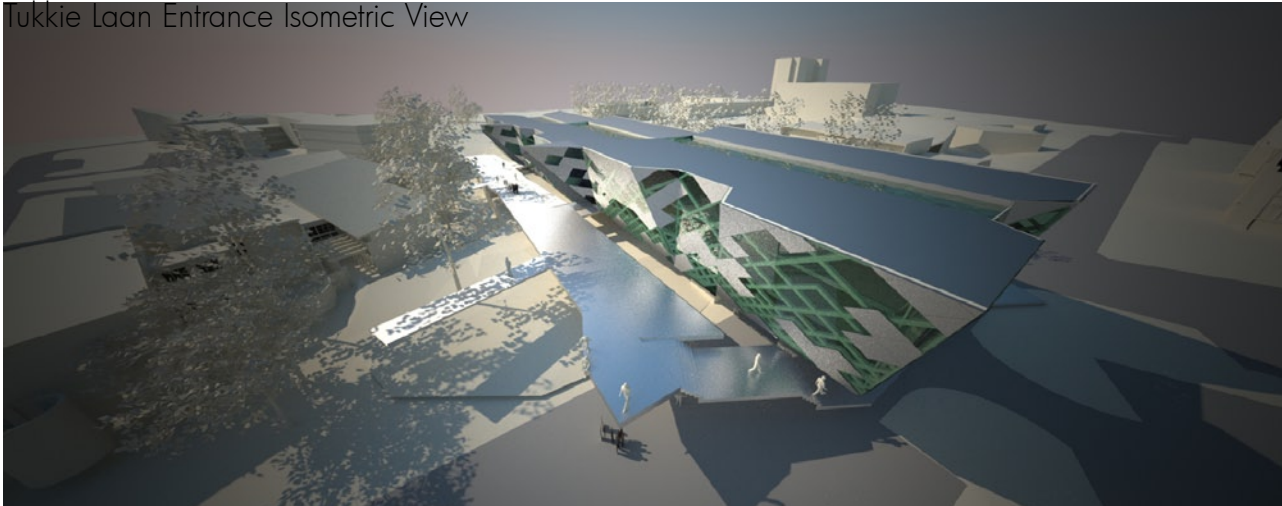

Tukkie Laan Entrance Isometric View

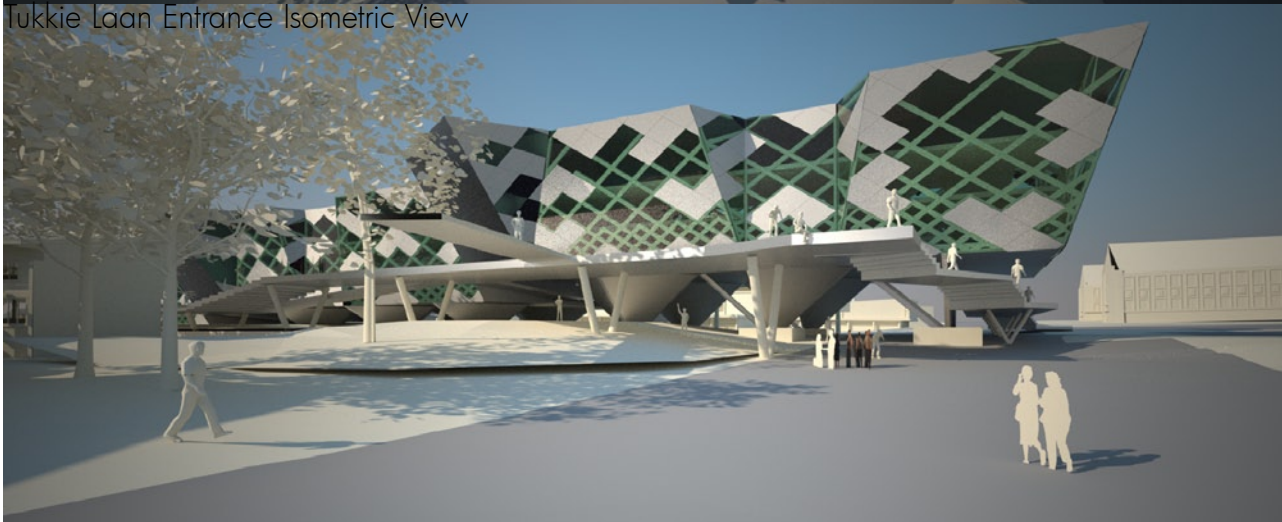

South Western Isometric View

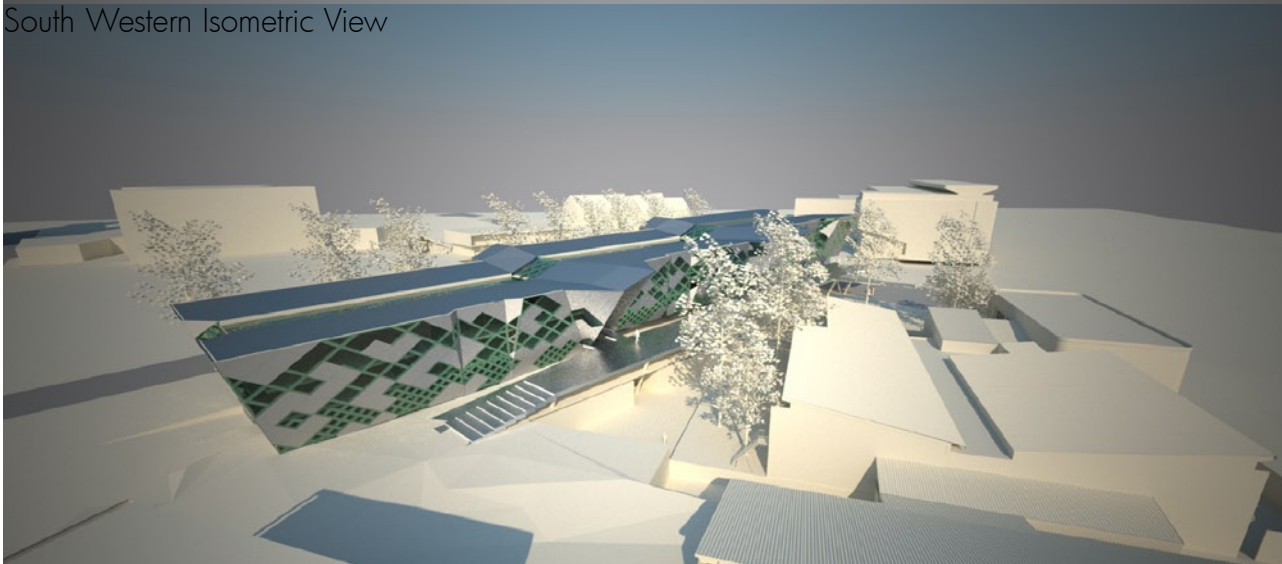



Tukkie Laan And Ring Road Intersection View

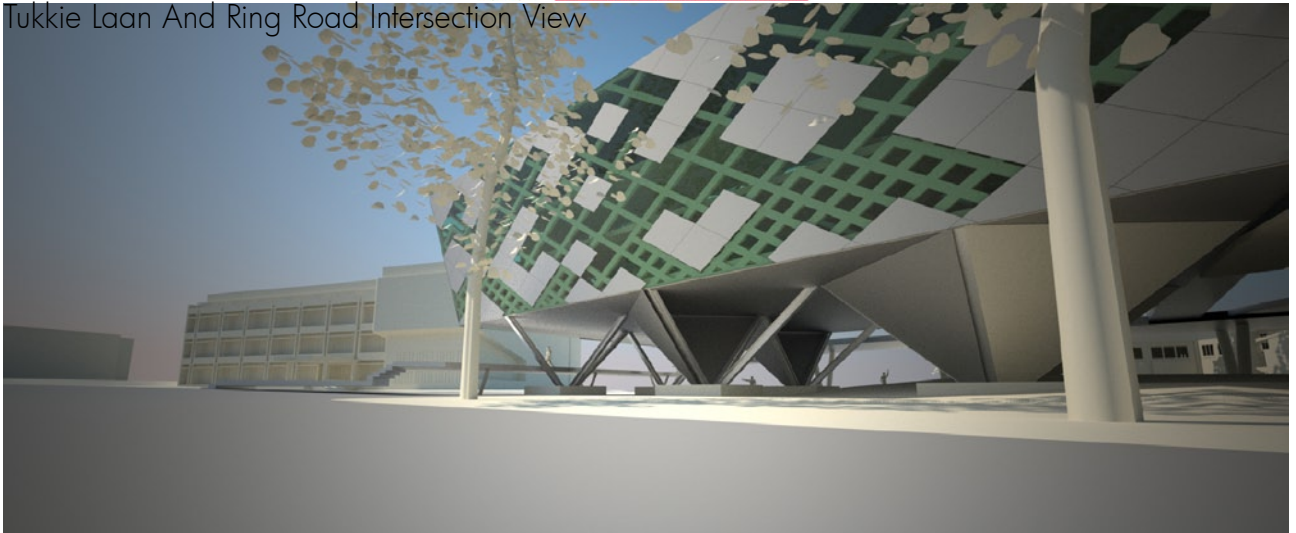

Western Elevation

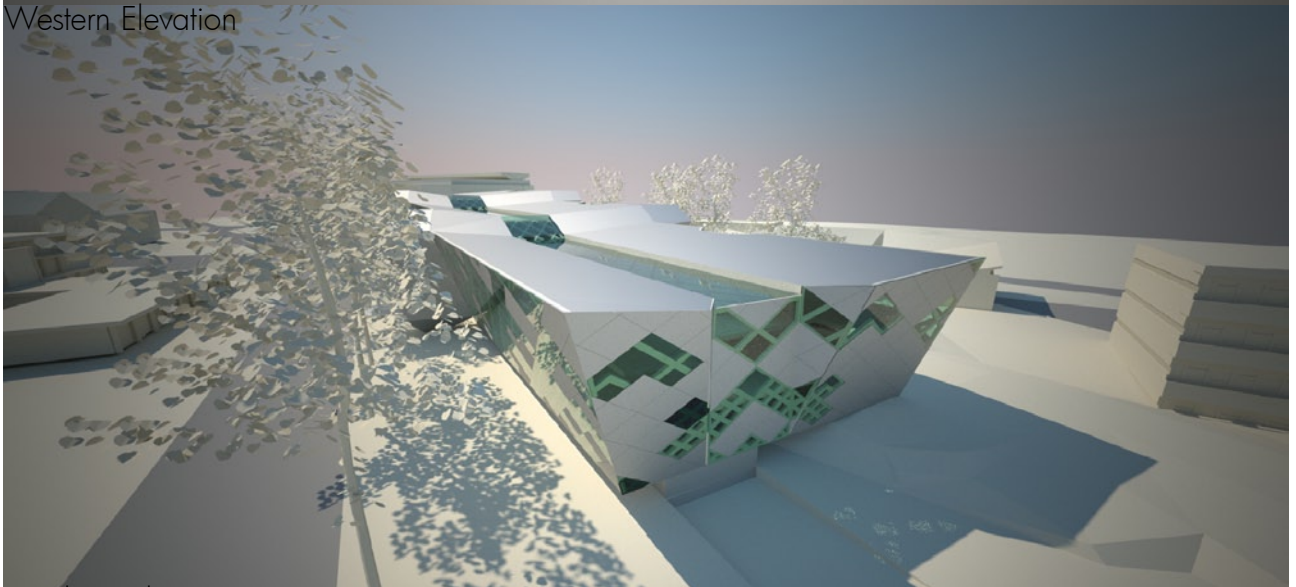

Northern Elevation

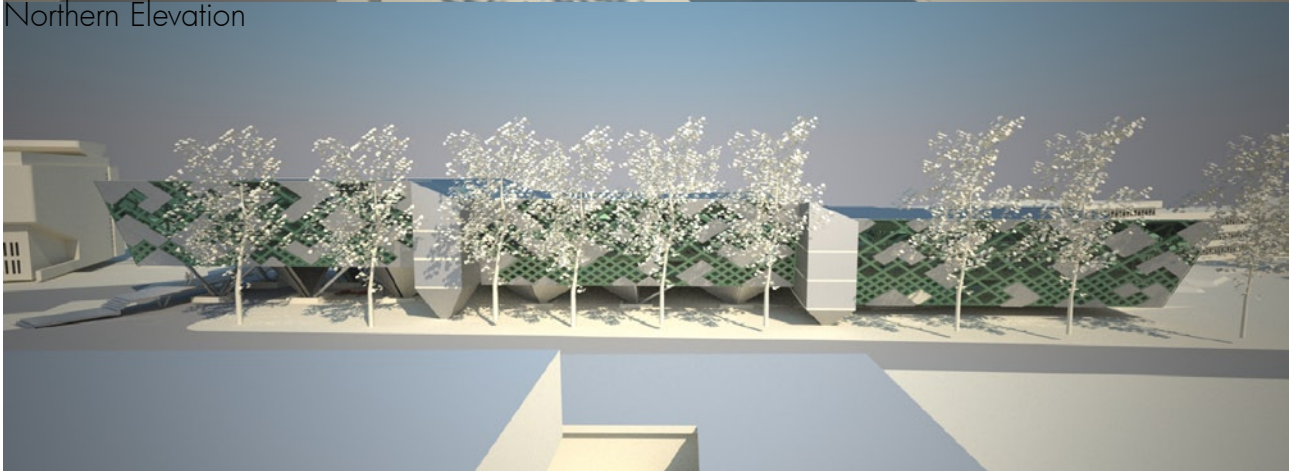



Main Walkway And Entrances View

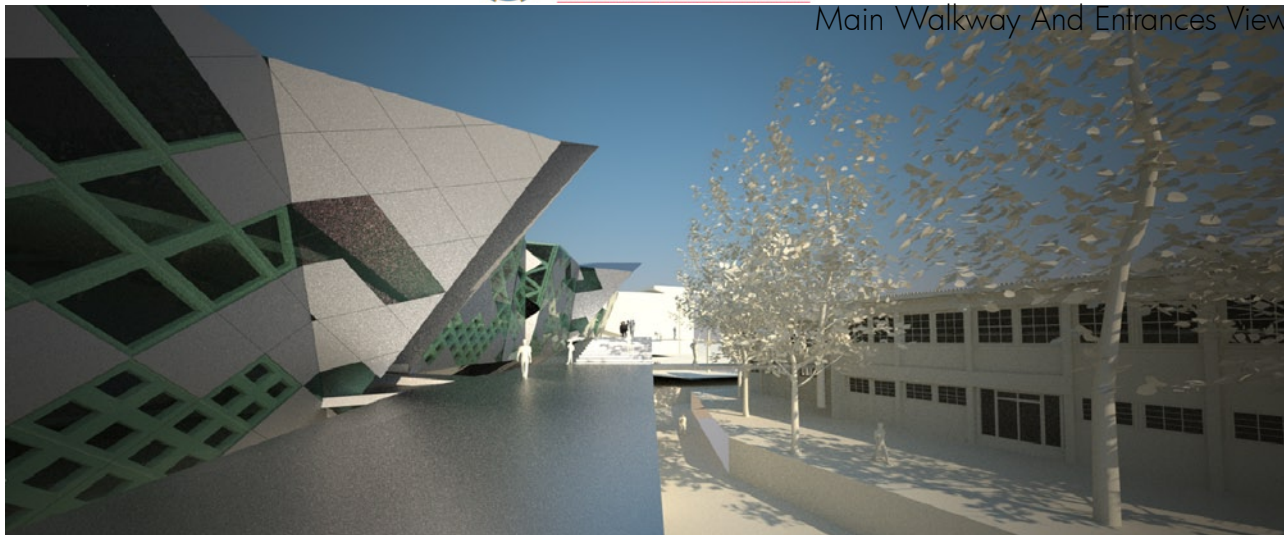

Main Walkway Detail View

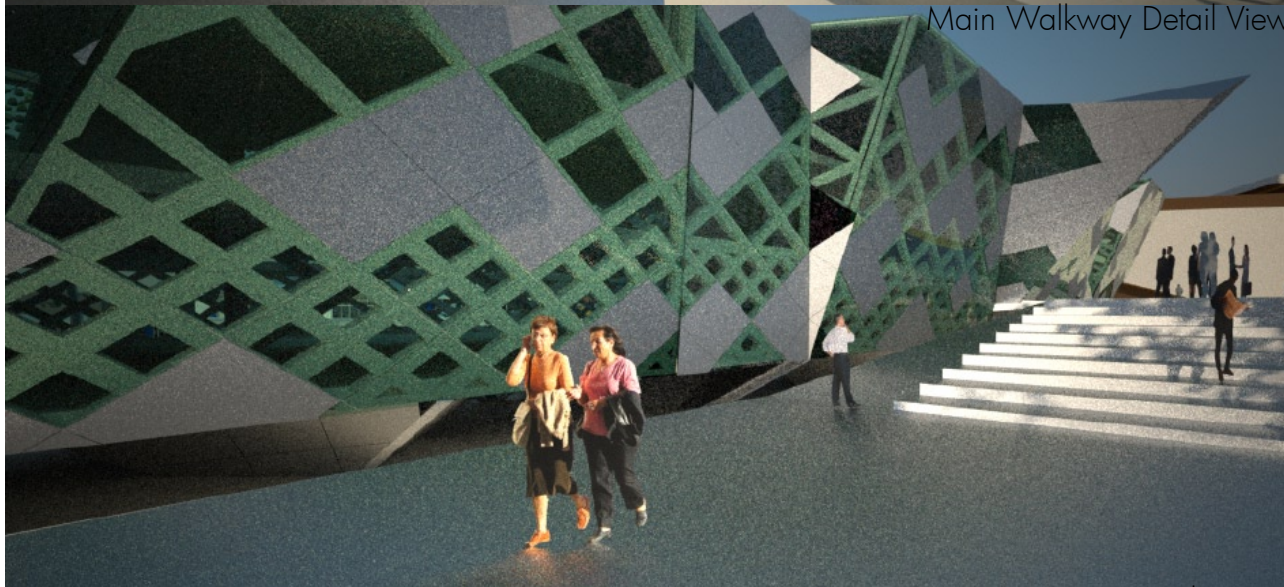

Eastern Elevation

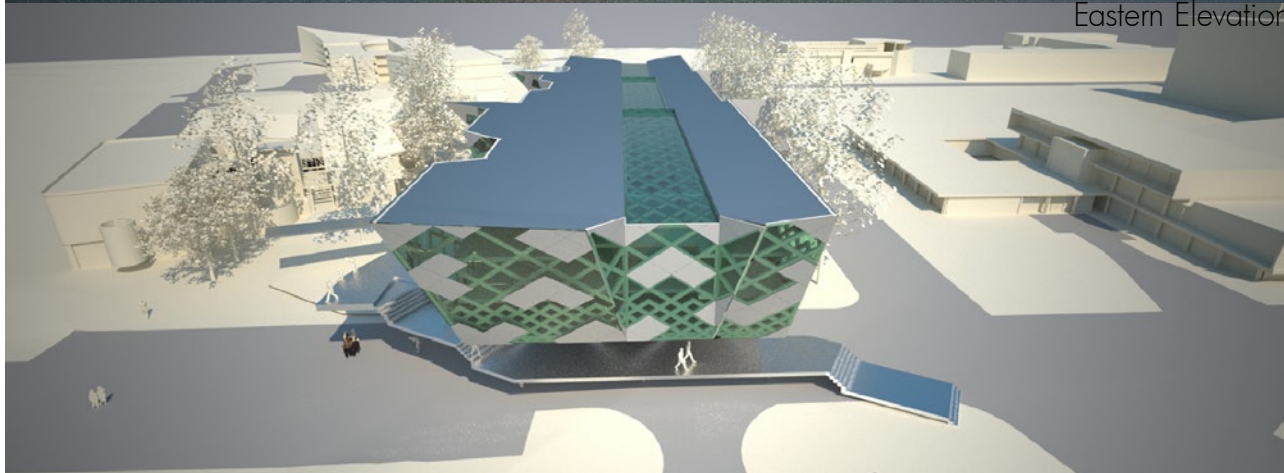



UNIVERSITEIT VAN PRETORIA
UNIVERSITY OF PRETORIA
YUNIBESITHI YA PRETORIA





TECHNICAL INVESTIGATION

+

+

INTRODUCTION 7.1

STRUCTURE 7.2

PLANNING 7.3

CLIMATE CONTROL 7.4

STORM WATER 7.5

MATERIALS 7.6

SERVICES DESIGN 7.7

CODES AND STANDARDS 7.8

SUSTAINABLE PARAMETERS 7.9

7.1 Introduction

The technical investigation and resolution in the students research facility is driven by the theories of architectural surface. Thus the investigation in to structure, systems and the rest of the technical components investigated in this chapter have focused on the design and development of an architectural surface as described in chapter 3.

7.2 Structure

The flexibility and adaptability that is required in today's research facility required the development of a bespoke structural system that could deliver these two important requirements. The provision of free space, without the impediment of structural elements is the main aim of the structural system.

The structural system comprises 5 main components including; foundation pads, main support columns, diagrid lattice frame, floor slabs and the space frame roof structure. (See figures 4,5 and 14-21)



Figure 7.1: Main structural components

7.2.1 Foundations

The entire structure is supported on eighteen foundation pads, six pads per research unit. The foundation pads are each 4x4x1m in size, they need to be constructed at a minimum base depth of 1.5m from natural ground level or where suitable bearing capacity is found. The foundation pads should be constructed of reinforced insitu cast concrete as per engineer's details.

The foundation pads act as `growth pods` for the rest of the structure to grow from. Due to this requirement they are recessed and need to be drained to a suitable geotextile ground drainage system and pump away, this is to prevent to contact of the structural steel system with water. (See Figures 4,5)

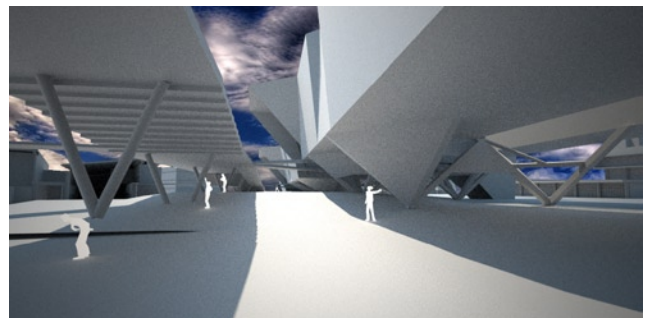
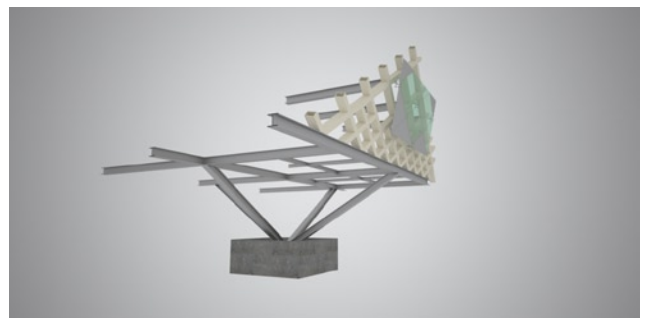

Figure 7.2: Conceptual rendering of main support Structures

Figure 7.3: Conceptual view of support structures



7.2.2 Main Support columns

The main support columns or pyramids are constructed using 305x305x20mm mild steel H-profiles. The columns are fixed to the base support structure and foundation pads as shown in details Section A-A and F, they are painted to a matt finish in in-tumescent paint to attain a fire rating of 120 minutes.

Figure 7.4: Conceptual view of support structure and weather screen to form epi surface structure

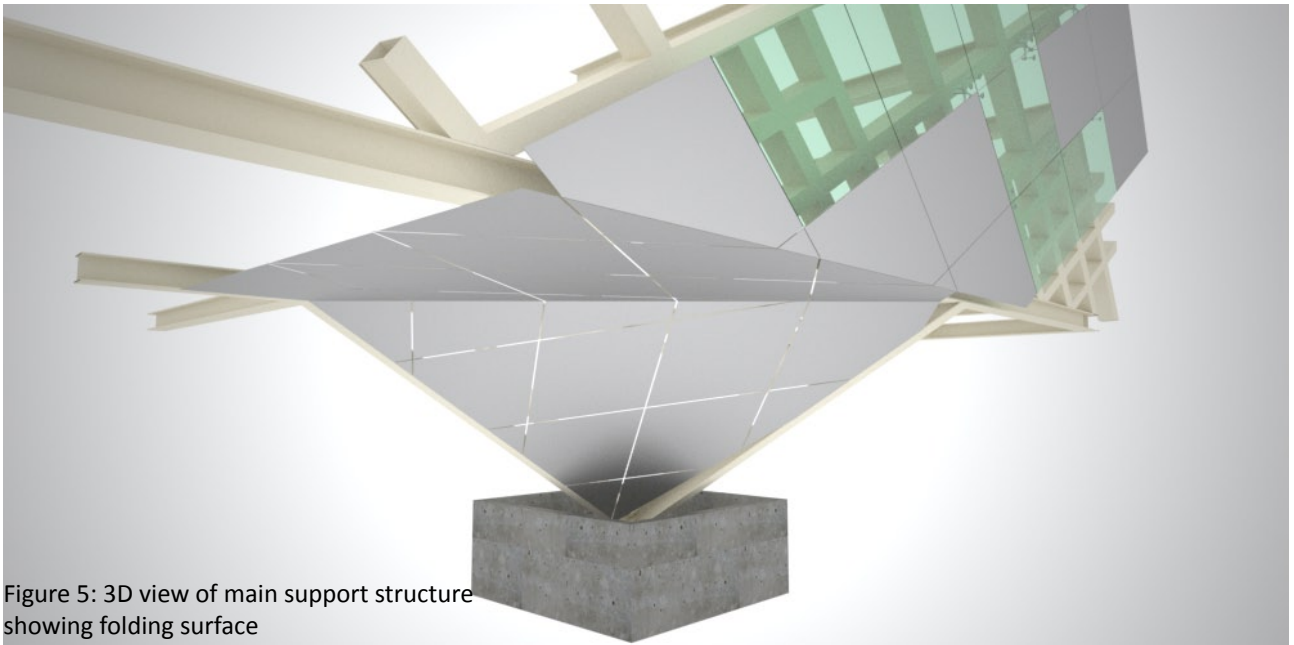
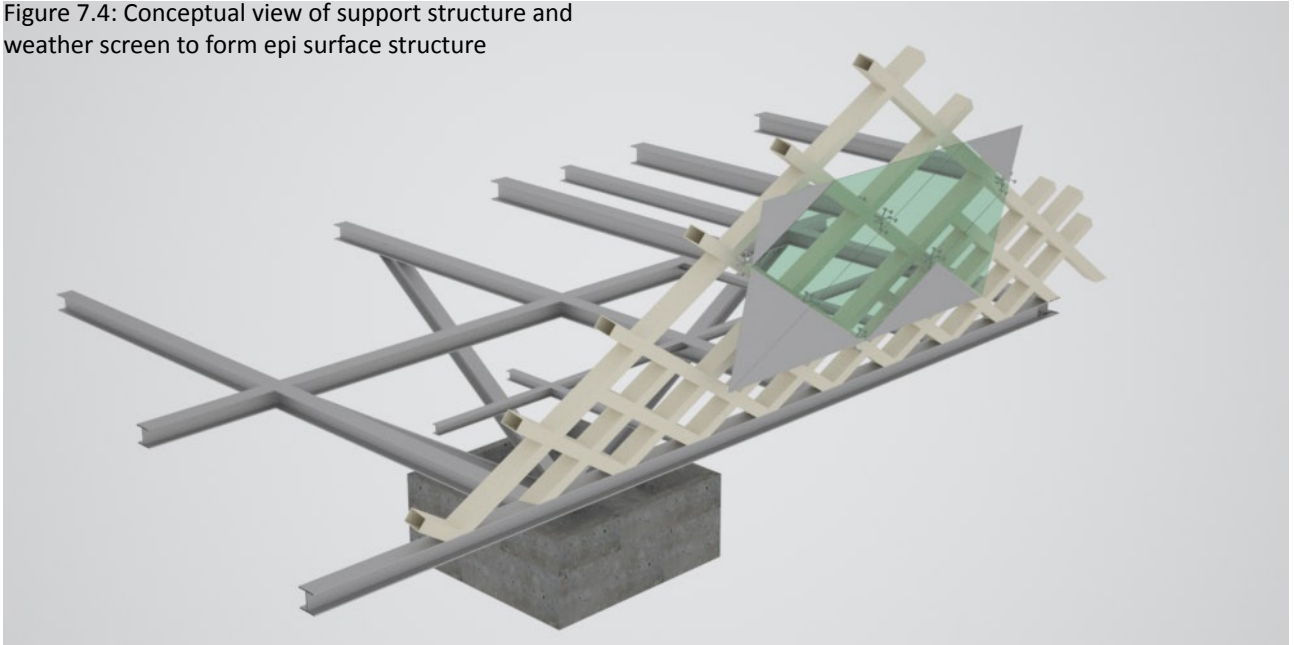

Figure 5: 3D view of main support structure showing folding surface

7.2.3 Lattice diagrid frame

The lattice diagrid structure is employed to transfer slab loads from envelope (surface) and atrium to the foundation pads. The surface structure thus liberates internal space from the imposed constraints of structure.

200x300x10mm Mild steel rectangular hollow sections are the structural components that are used in the lattice frame assembly. The diagrid lattice structure forms the surface structure of the facility that folds, wraps, encloses and supports the spatial requirements of the research facility.

The frame assembly is developed in a three tier hierarchy comprising primary, secondary and tertiary structural elements. The primary structural elements are designed to be contiguous and transfer most of the gravity loads. They are fully welded with 6mm fillet weld at their intersection, braced and joined where they intersect with custom manufactured X-brace plates. The brace plates are manufactured from 10mm mild steel sheets and are fully welded to the connections using 6mm fillet welds. In the hierarchy of elements the secondary structural elements provide a support service to the primary elements as well as a stiffening service to the entire structure. Lastly the tertiary elements serve as stiffening in fill panels as well as solar shading devices where required due to their dense nature. (See figures 9,10,13 and 14 - 21)

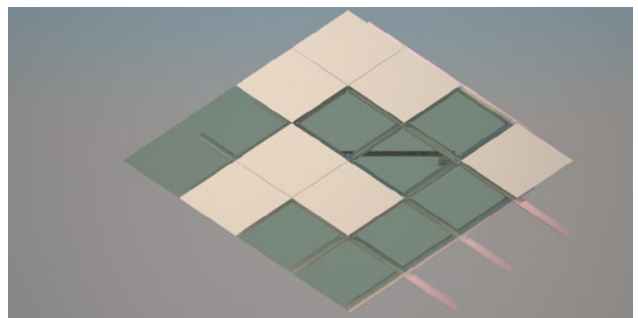
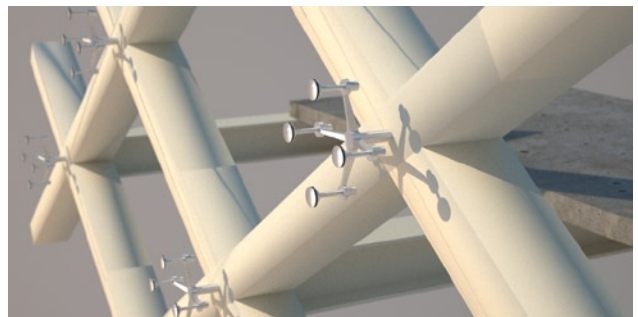

Figure 7.6-8: Conceptual structural renderings

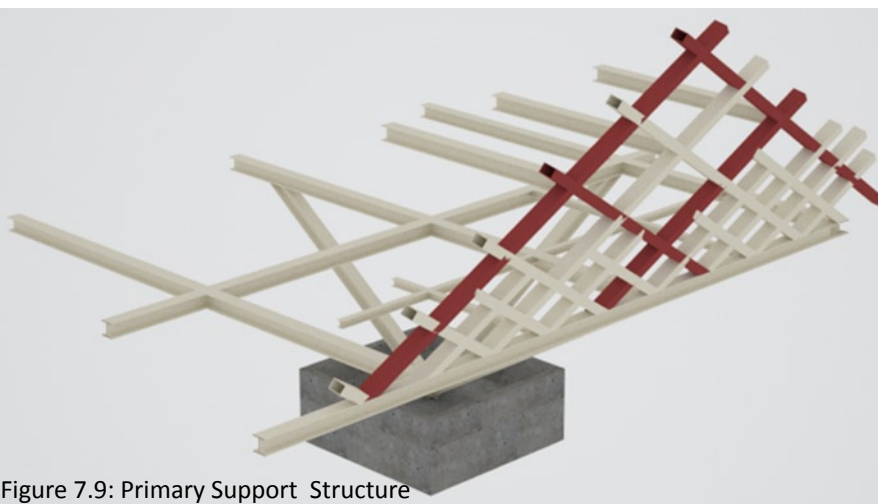

Figure 7.9: Primary Support Structure

Figure 7.10: Secondary Support Structure



7.2.4 Floor Slabs

Due to the spatial and structural requirements of the research facility it required a floor slab system that is lightweight, slim, provides long enough single spans and structural stiffness to the facility. The system that is employed throughout the facility is that of composite floor deck system.

Composite floor deck systems as employed in the research facility comprise a number of components. These components include a structural 1mm gauge galvanized mild steel deck, A142 anti crack mesh, cast insitu concrete and shear studs. The total slab depth is 130mm over a 3m single span. Connection between composite floor slabs and supporting beams is achieved thru the welding of shear studs to the structure at 300mm centres and a minimum of 100mm from the slabs edge. A maximum coverage of 30mm and minimum 15mm is to be achieved over the applied anti-crack mesh, with a minimum end lap of 300mm

Supporting and transferring loads from the composite floor slabs are 305x305x10mm H-profile beams @ 3000mm centres, these beams are fully connected to the facade and atrium lattice frames using 6mm fillet welds and connection plates where required. (See figures 11,12)

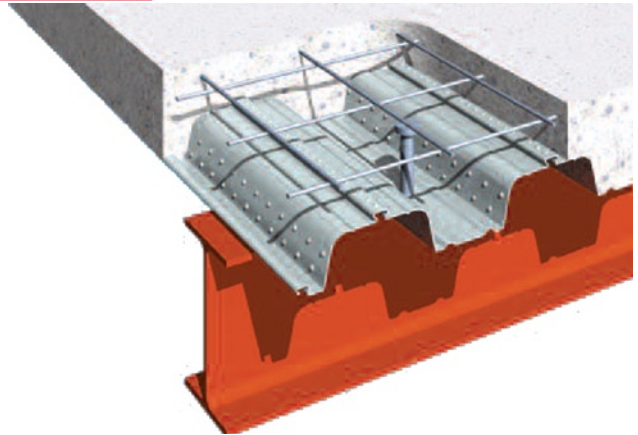

Figure 7.11: Composite floor deck components



Figure 7.12: Photograph of floor before finish

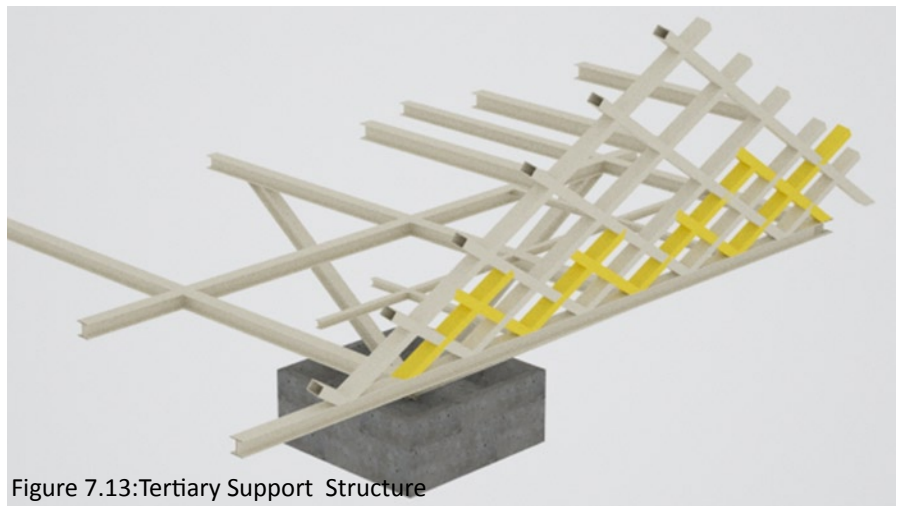

Figure 7.13:Tertiary Support Structure



Structural assembly diagrams

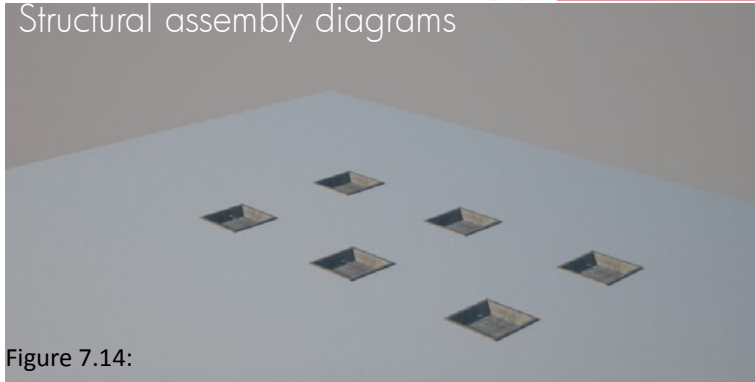

Figure 7.14:

1 FOUNDATION PADS

- 4000x4000x1000mm Reinforced concrete foundation as per engineers specifications

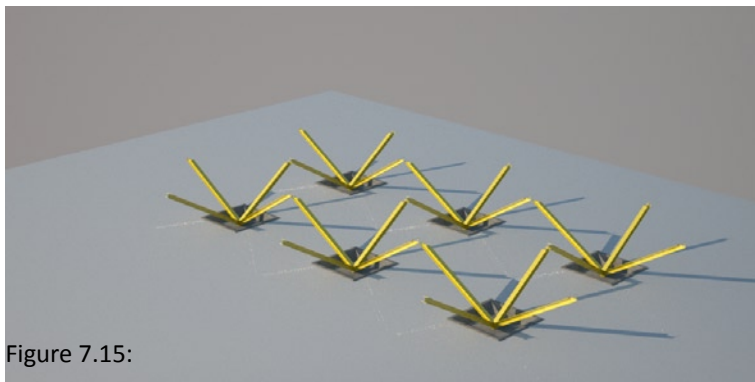

Figure 7.15:

2 MAIN SUPPORT COLUMNS

- 305x305mm H-profile main support columns primed and painted with intumescent paint to a mat finish, connected to pads as per detail F. Bottom 150mm of columns and gusset plate connections to be painted with bitumen based paint as water proofing

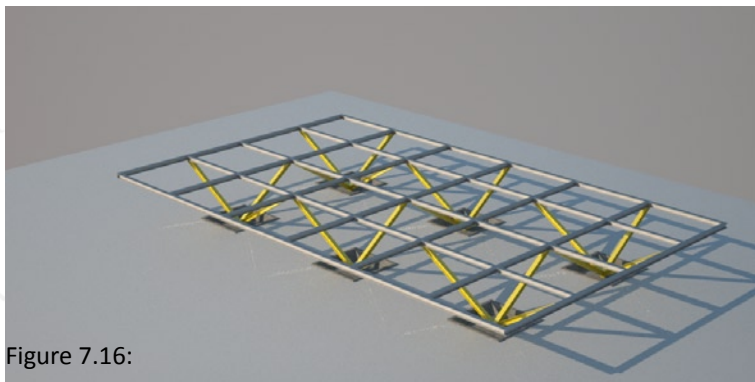

Figure 7.16:

3 PRIMARY BASE BEAM

- 305x305mm H-profile primary base beams form the main platform that supports the upper structure and transfers all loads to the support columns and foundations. Set out to main structural grid

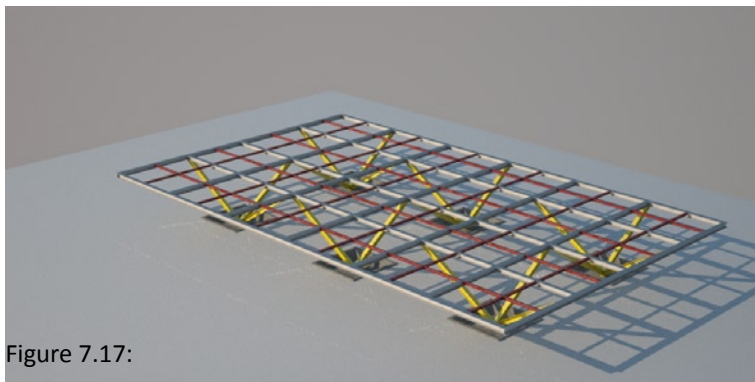

Figure 7.17:

4 SECONDARY BASE BEAMS

- 152x152mm H-profile secondary base beams



5 ATRIUM LATTICE FRAME

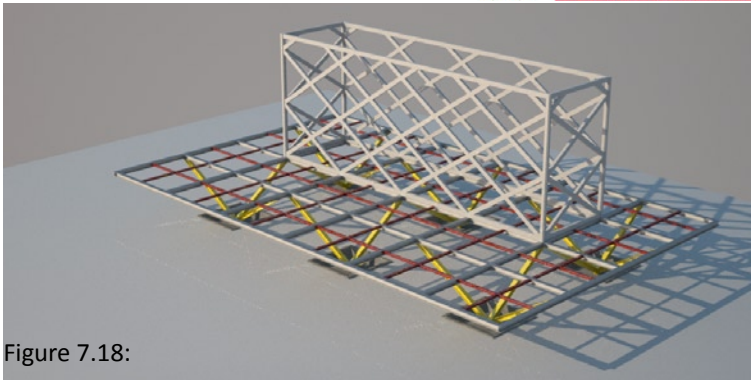

Figure 7.18:

- 300x200x10mm mild steel RHS atrium lattice frame is the only internal support structure within the spatial confines of the facility

6 FLOOR BEAMS

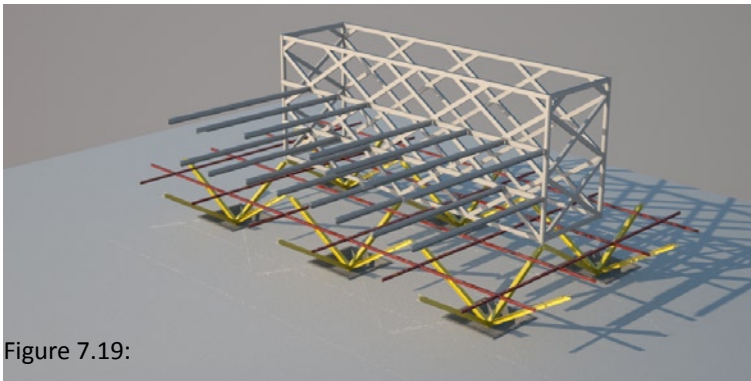

Figure 7.19:

- 305x305mm H-profile beams act as main floor slab support structure and connect external surface lattice frame to the atrium lattice frame

7 MAIN FACADE LATTICE FRAME

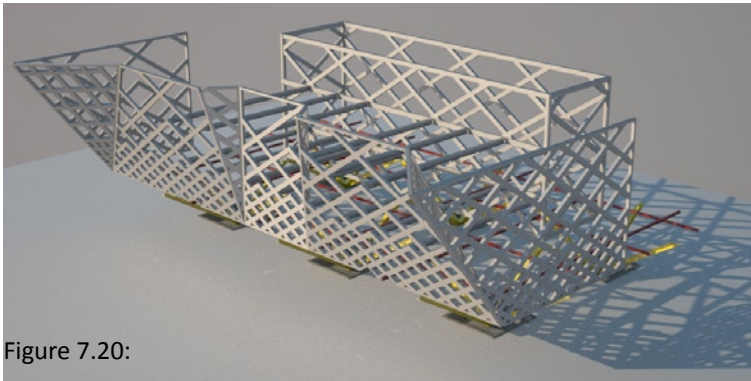

Figure 7.20:

- 300x200x10mm mild steel RHS atrium lattice frame serves as the main structural component in the facility

8 FLOOR SLABS

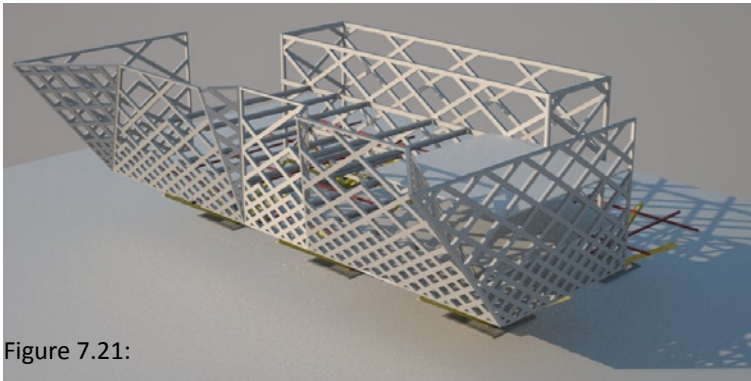

Figure 7.21:

- 130mm Composite cast insitu concrete floor slabs .

7.2.5 Roof Structure

A space frame roof structure presented to be the most suitable structural solution to the requirements of the facility. The space frame has numerous qualities that make it an appropriate structural selection including long spans with relative small depth, light weight, easy construction, materials efficiency and space for services accommodation. The only negative consideration when using a space frame is the fact that they are difficult to design.

I chose to use the diagrid space frame structure; it seamlessly integrates with the diagrid lattice frame of the architectural surface as well as providing the most efficient span to depth ratio for a space frame structure.

Mero-TSK is the proposed node system for the space frame construction, it is modular and the system comprising 40mm mild steel tube as cord and bracing members with cast round node points. The proposed finish to the space frame is a powder coat finish.

The total roof deck structure is made up out of:

- 1 - Space Frame
- 2- 12mm Plywood decking
- 3 - 100mm Kingspan K11 Insulating roof board
- 4 - Breather membrane
- 5 - Zinc Standing seam roof cladding

Figure 7.25: 3D view of proposed Roof structure make up, see sections.

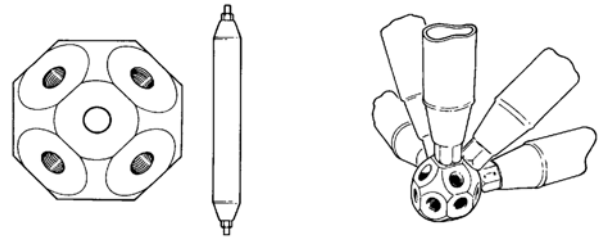
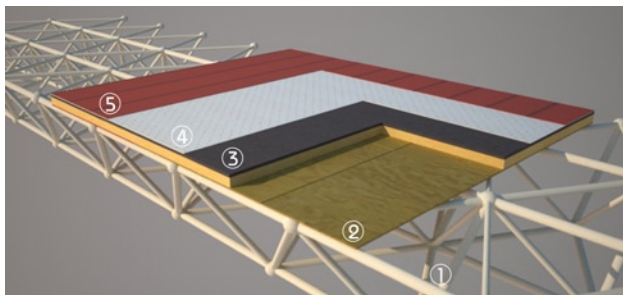

Figure 7.22: Mero TSk node system

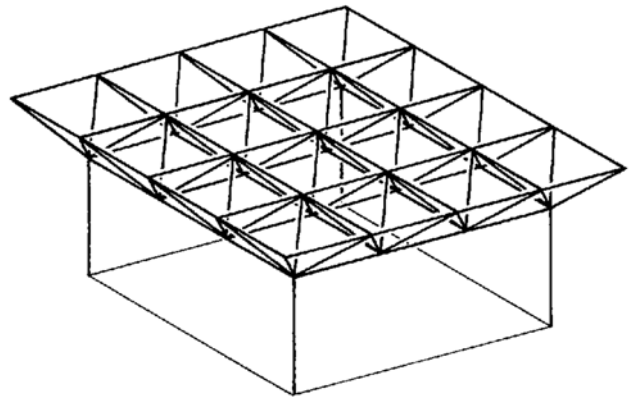
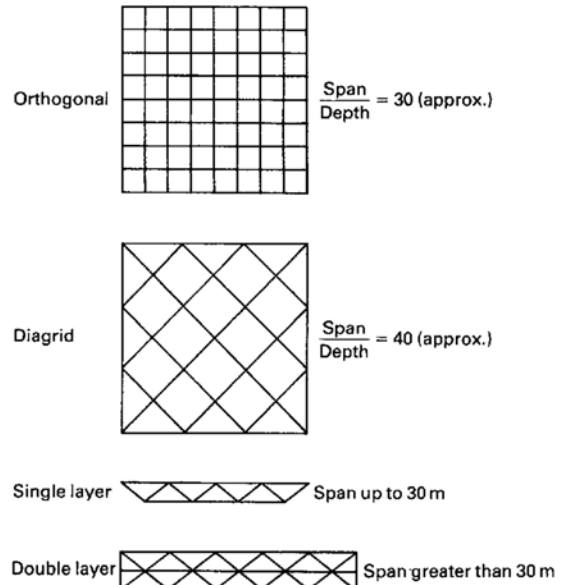

Figure 7.23: Diagrid space frame structure

Figure 7.24: Common space frame span to depth ratios



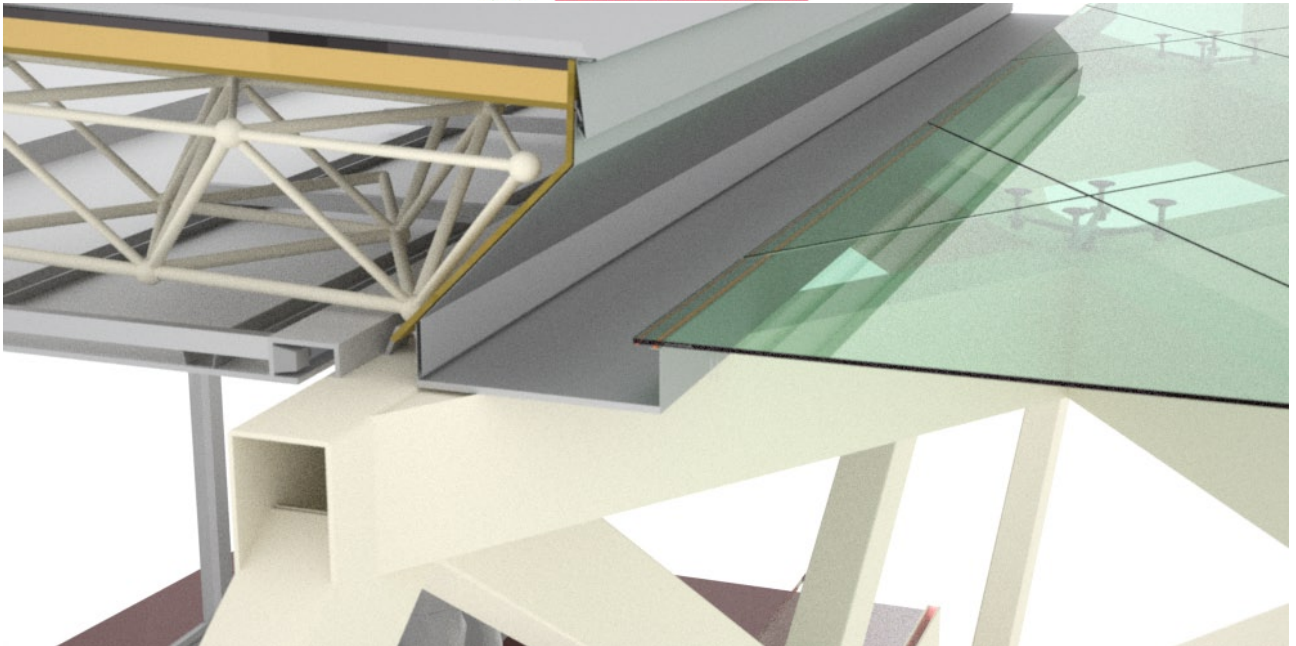

Figure 7.26: 3D rendering of roof construction at atrium junction

Figure 7.27: View of atrium structure and glazing

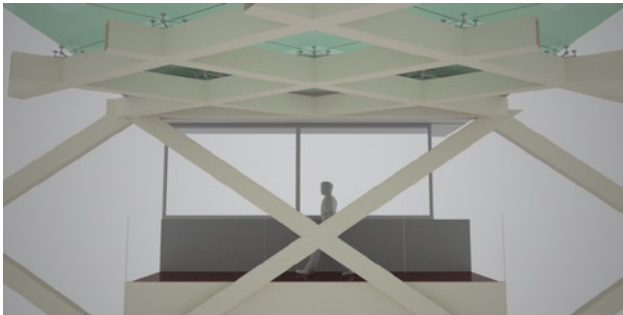

Figure 7.28: View from support zone to atrium

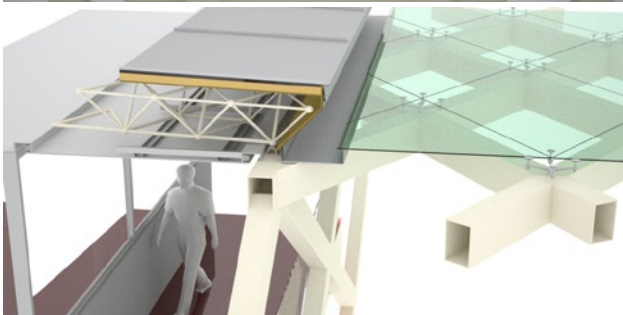
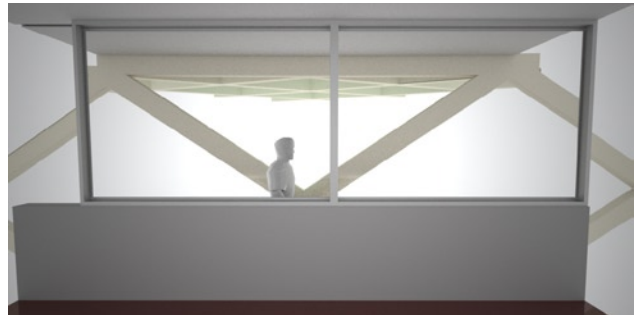

Figure 7.29: 3D rendering of atrium and circulation zones



Figure 7.30: View of atrium circulation space

7.3 Facility Planning

6.3.1 Introduction

Research facilities in their simplest form present a complex planning task to any designer. In today climate of technology change and output driven research environments, planning of an optimal functioning research facility becomes all the more complex. Some of the key guiding principles of contemporary research lab design and my research facility include:

Design for change – All decisions should be made on the premise that functions, staff, space and location will change. (Griffin,2005)

Design for the computer – More and more task today are completed in the virtual environment (Griffin,2005)

Break down barriers – Involve scientist from various disciplines (Griffin,2005)

Facilitate creativity – Designers can bring scientists together by facilitating chance encounters (Interaction), and providing inspiring spaces (Griffin,2005)

Design Generic not specific – Laboratories should be generic in size and layout and based on the optimum lab module size, to accommodate various layout and uses (Griffin,2005)

Connectivity – Celebrate circulation throughout the facility, place in public zone to facilitate a sense of community (Griffin,2005)

While keeping the above mentioned design objectives in mind the facility is planned around 5 key zones:

A – Research and Support zone

B – Connective Atrium (communal street) zone

C – Academic, Interactional and support zone

D – Building Services Core zone (Horizontal Circulation, Services riser, mechanical and plant rooms, Bathrooms and Main entrances)

E – Transitional Spaces zone

Figure 7.31: Zone planning diagram

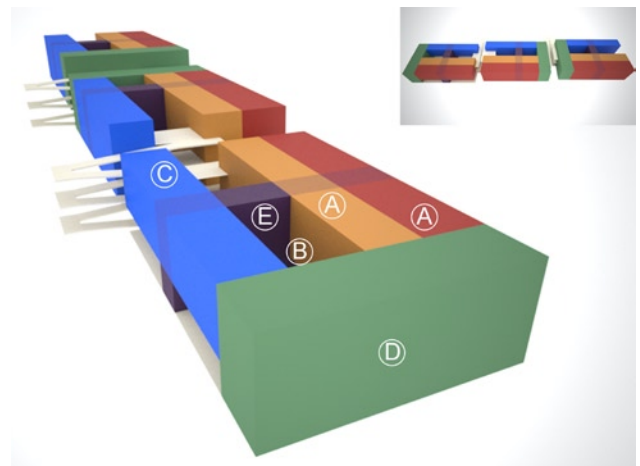

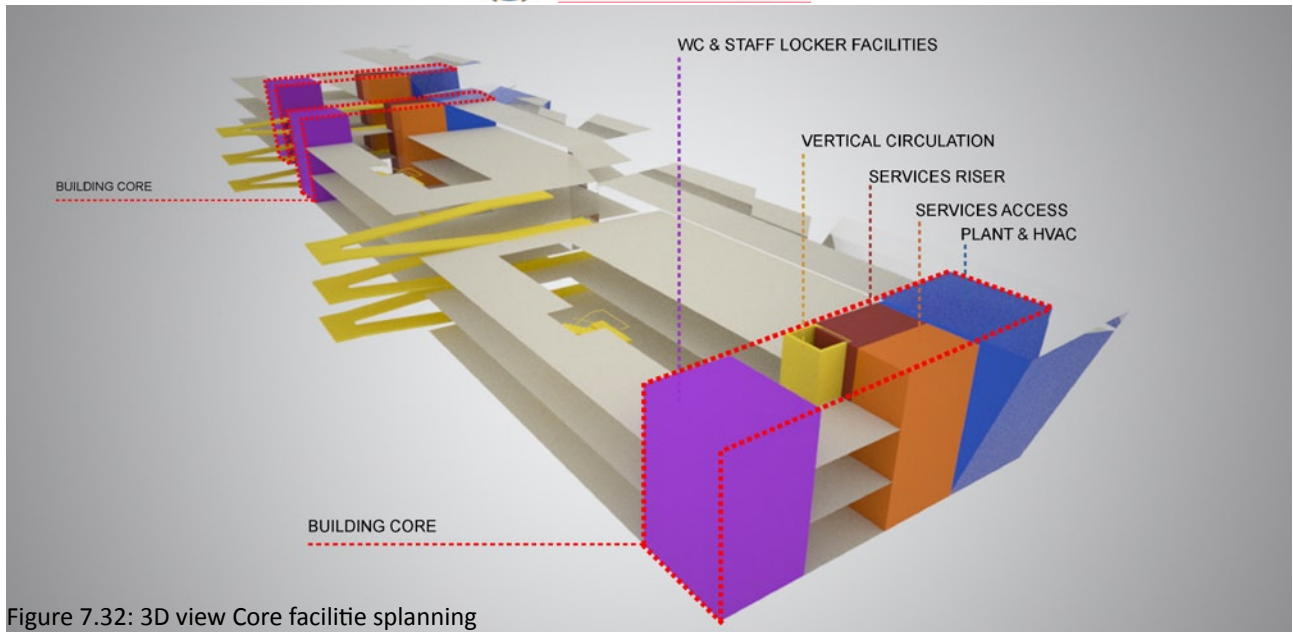

Figure 7.32: 3D view Core facility planning

6.3.2 Zone Planning

Structural Module development

Planning of the research and research support zones required the study of numerous case studies to attain the optimum and most flexible research module size. The module size that was deemed most suitable to flexible research environments is that of 3m x 3m and its duplicated of 6m x 6m. Thus any subdivision within this spatial module would be applicable to research spatial requirements. The research support zone, the zone where all shared equipment and facilities is located requires the same module size of 3m as well as a 2m circulation width.

From these two planning module sizes the structural grid for the facility was determined. The structural grid reads as 6m (research module) – 5m (support & circulation) – 6m (atrium) – 5m (interaction & academic) in a south to north direction and a consistent 6m structural module from west to east only changing to 5m where main entrance are located.

Further to the structural module development the facility is subject to horizontal and vertical zone development.

Horizontal Zones

Interaction is one of the key driving forces behind the horizontal zone development of the facility. Planning as to ensure that different users in the facility are giving more opportunity to interact and meet, either by choice or chance.

As mentioned earlier the building is divided into five key horizontal zones A-E.

Zone A can be defined as the research zone where all research labs and research support zones are located.

Zone B the linear connective atrium is designed as the communal spill out space within the facility. Productive and inventive research takes place in facilities where a sense of community exists and change encounters are facilitated. The atrium space is designed as a communal 'street', a main spine from where and onto where all functions and spaces in the facility join on to and open on to.



Zone C is defined as the academic and interactional support zone. This zone contains the programmatic functions that incorporate the rest of the academic environment from students to lecturers and researchers and is a multi disciplinary, multifunctional zone (can be seen as the community hall zone)

Zone D is the only fixed zone in the facility in terms of structure. The fixed core zone is classified as the only in adaptable space within the facility; it contains the vital services that are required for a research facility to function. This zone contains the Horizontal Circulation, Services riser, mechanical and plant rooms, Bathrooms and Main entrances.

Zone E, Transitional spaces abuts with and intersects zone B (atrium) directly, this zone is orientated to key external views as discussed earlier. Within this zone is located vertical circulation staircases and transition spaces. The location of this zone within the near middle of each unit and the location of the vertical circulation serves to enhance the sense of community.

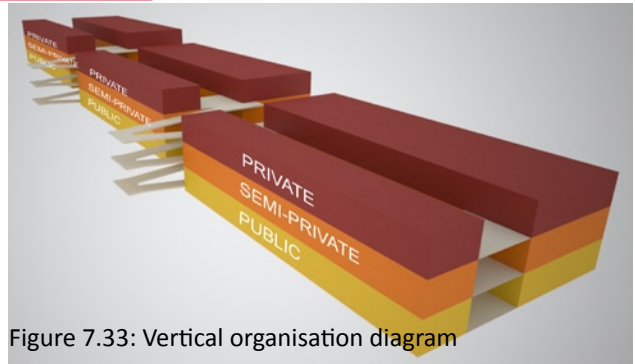

Figure 7.33: Vertical organisation diagram

Vertical Zones

Spatial division from public to private is the main purpose of the vertical zone implementation within the facility. Three distinct vertical zones are identifiable within the research zones, public spaces at the lowest level; including teaching laboratories, the atrium zone and open project labs. The second level is known as the open lab zone, where open research labs and more private functions are located, the third level is known as the closed lab zone. Within the closed lab zone more private and sensitive research is undertaken, as well as more private functions needed in the other zones.





UNIVERSITEIT VAN PRETORIA
UNIVERSITY OF PRETORIA
YUNIBESITHI YA PRETORIA

7.4 Climate control

Climate control in the research facility is designed to achieve optimum comfort for all occupants at all times. Comfort can be described as a balance of four key elements:

Light - visual environment

Heat – Thermal environment

Noise – Acoustic environment

Smell – Air quality

(<http://www.battlemccarthy.com/Double%20Skin%20Website/environmentalchar/doubles...>,10/09/2008)

The climate control design for research facility is optimised to give equal importance and attention to each of the above for factors. Due to the energy intensive nature of a research facility it is important to employ as many sustainable climate control techniques as possible where possible throughout the facility.

7.4.1 Ventilation (Thermal, Acoustic, Visual, Air quality)

The ventilation strategy for the research facility is a hybrid system; because of the HVAC recruitments of certain functions within the program it is not possible to do a 100% passive ventilation system. The ventilation design system comprises two systems, mechanically ventilated zones and assisted passive ventilation zones as indicated in the ventilation diagrams. The ventilation system is designed around a deep surface envelope system. (See diagrams 34-40)

The passive ventilation system in the facility is based on the stack effect or buoyancy ventilation, assisted by hybrid (solar and mains) powered heat extractor linked to BMS when required.

The use of a deep surface envelope has one drawback that is the initial capital input required to construct such a system. However the positive benefits out way the negatives by far especially in a Research

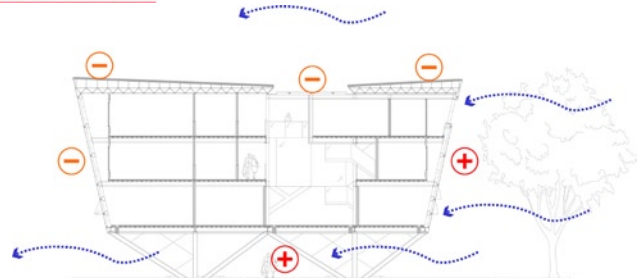

Figure 7.34: Prevalent wind direction effect on air pressure and passive ventilation

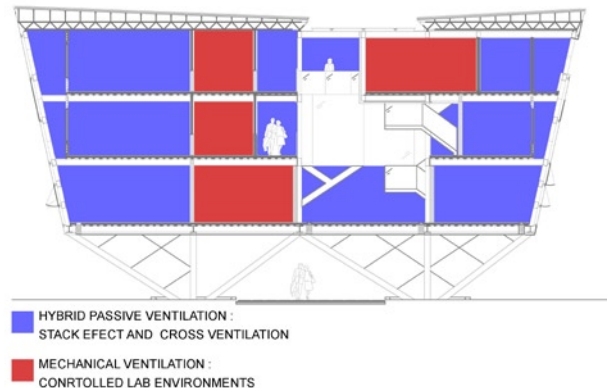

Figure 7.35: Ventilation zones

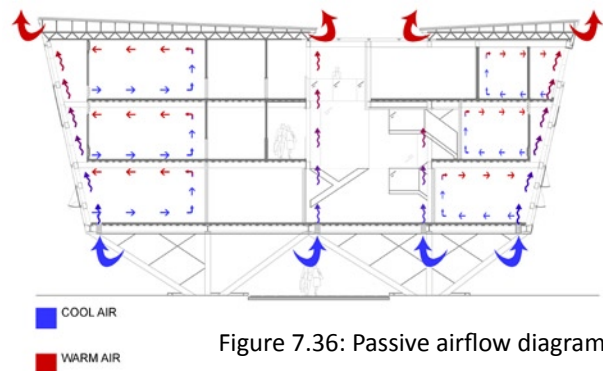

Figure 7.36: Passive airflow diagram

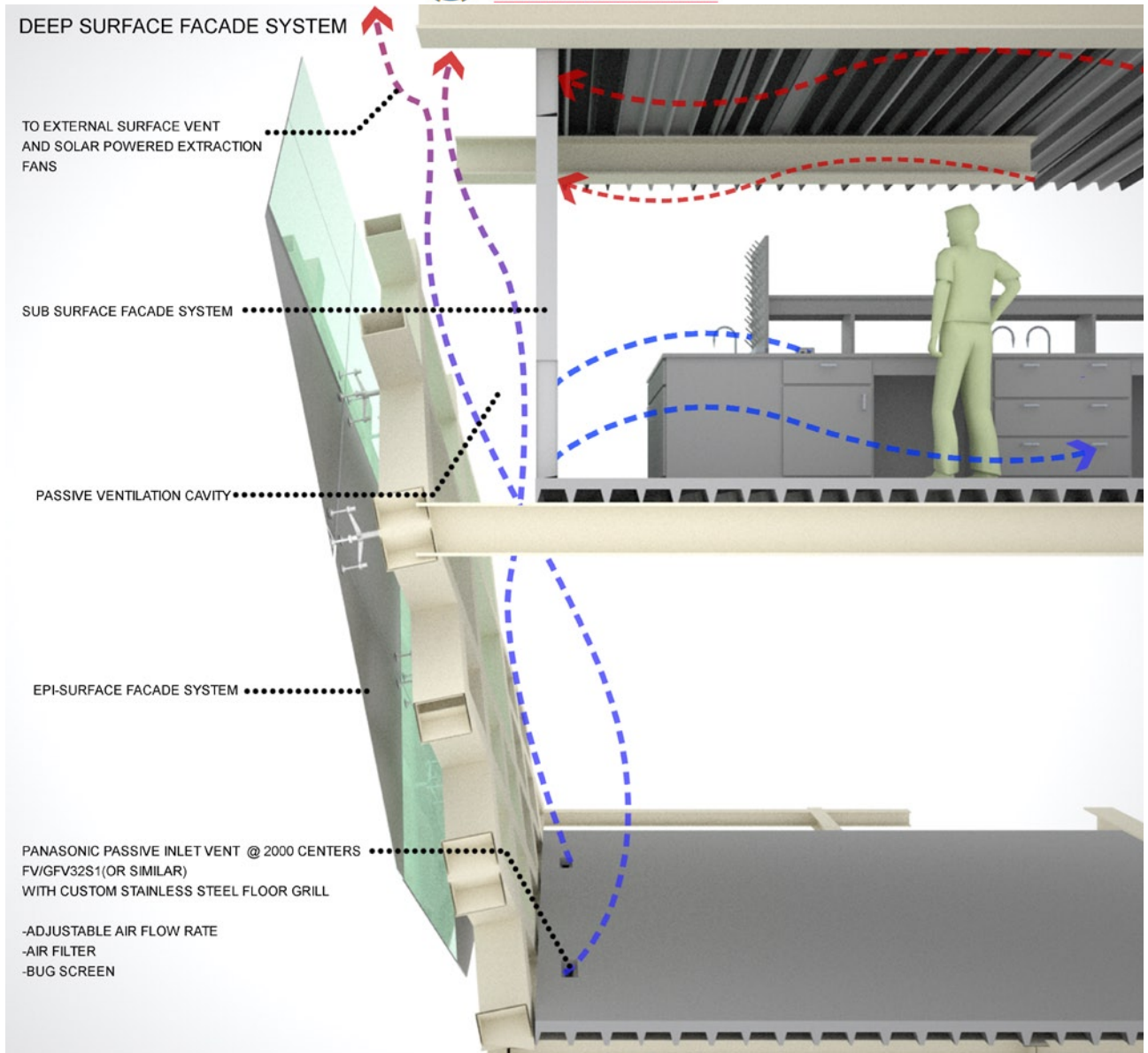

Figure 7.37: Deep surface hybrid ventilation system

A. Natural ventilation – Both passive day time and night time cooling

B. Better acoustic insulation - With a deep surface facade it is possible to achieve excellent acoustic insulation with the windows open, comparable with that obtained in traditional glass facades with the windows closed.

C. Reduced heating and cooling energy requirements - In winter, the air in the deep surface is heated by the sun, as a result improving both the heat insulating functions of the facade and its thermal performance, as well as reducing heating costs. With natural ventilation, so-called night cooling can significantly reduce the costs of air-conditioning in the summer



D. Security – Ventilation can take place at all time without creating a security risk the occupants of the facility

EPI-SURFACE FACADE SYSTEM

EPI-SURFACE : WEATHER SCREEN

- SMART GLASS COOLVUE S30 GLAZING
- ALUMINIUM FACADE CLADDING PANLES
- OPERABLE WINDOWS ON SPRING LOADED
- ACTUATER SYSTEM LINK TO BEM SOFTWARE

EPI-SURFACE : SUPPORT

- GLAZING AND PANELS MOUNTED ON
- PILKINGTONS PLANAR EDGE SUPPORT
- GLAZING SYSTEM

EPI-SURFACE : STRUCTURE

- DIAGRID LATTICE FRAME STRUCTURE
- LATTICE AS STRUCTURE, SHADING DEVICE
- AND REFLECTOR

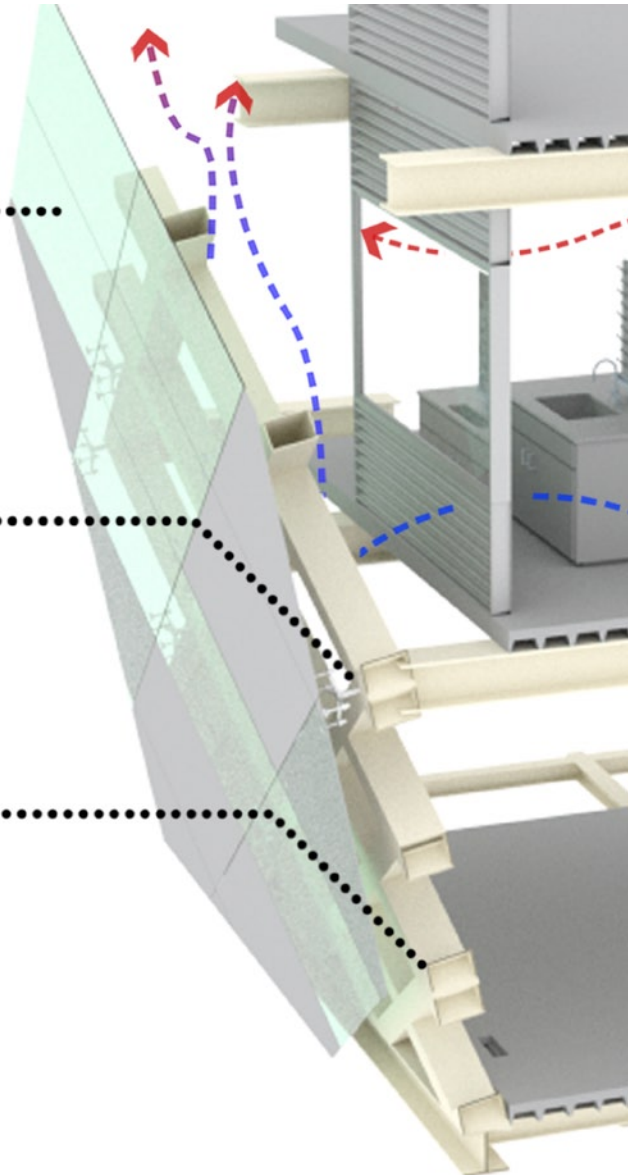

Figure 7.38: External components to deep surface (weather screen)

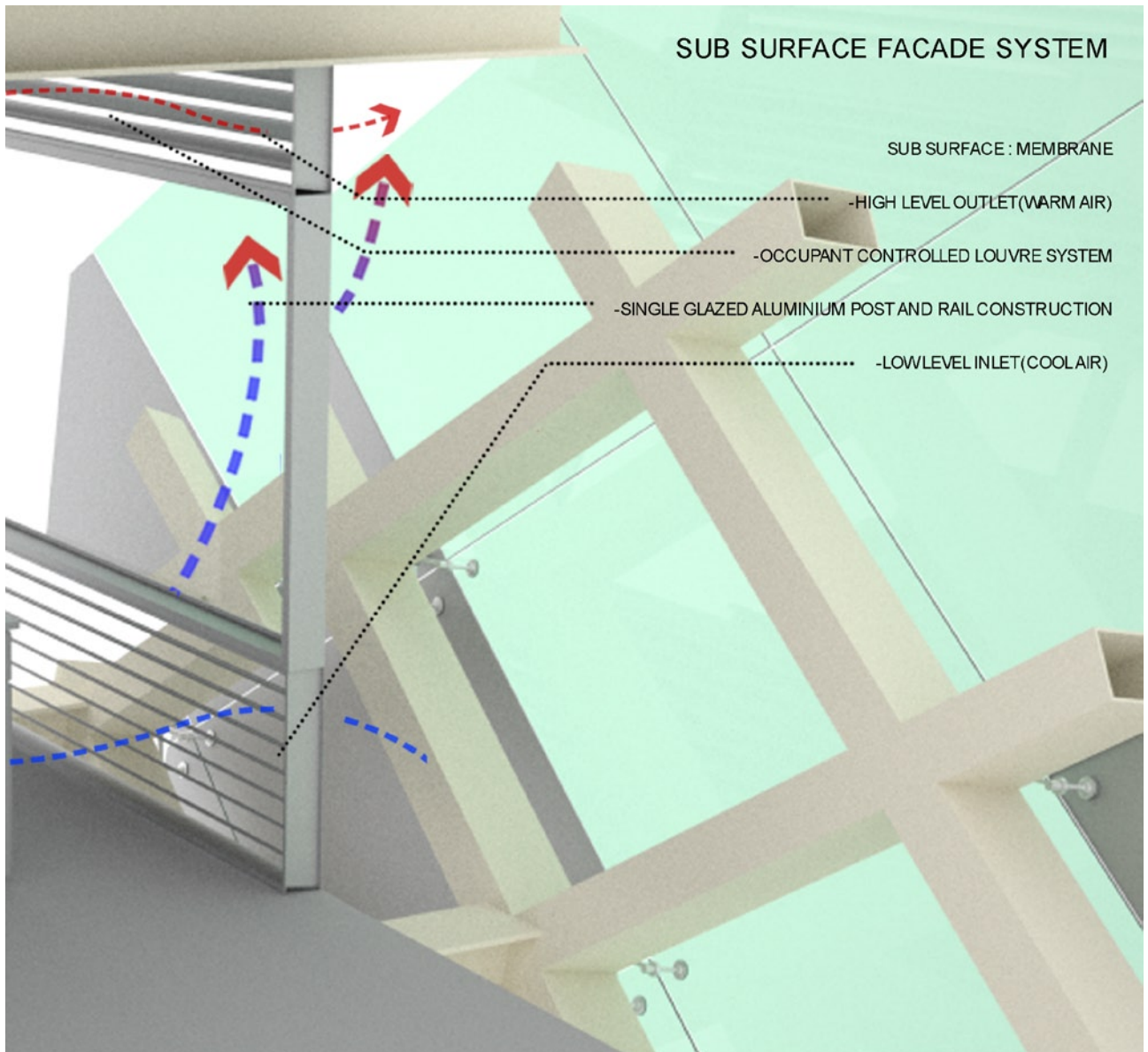

Figure 7.39: Internal components to deep surface (sub surface membrane)



DEEP SURFACE FACADE SYSTEM

HYBRID BUOYANCY VENTILATION:

IN LINE BOX FAN AND DUCTING POWERED BY HYBRID SYSTEM
MOVES MAXIMUM OF 6M³ PER MINUTE @10M CENTERS
TO ASSIST PASSIVE VENTILATION WHEN REQUIRED AS
DETERMINED BY BMS

SPACE FRAME ROOF STRUCTURE

COMPOSITE SLAB DECK PAINTED TO MATT BLACK FINISH

PERISTITIAL VENTILATION AND SERVICES SUPPLY ZONE

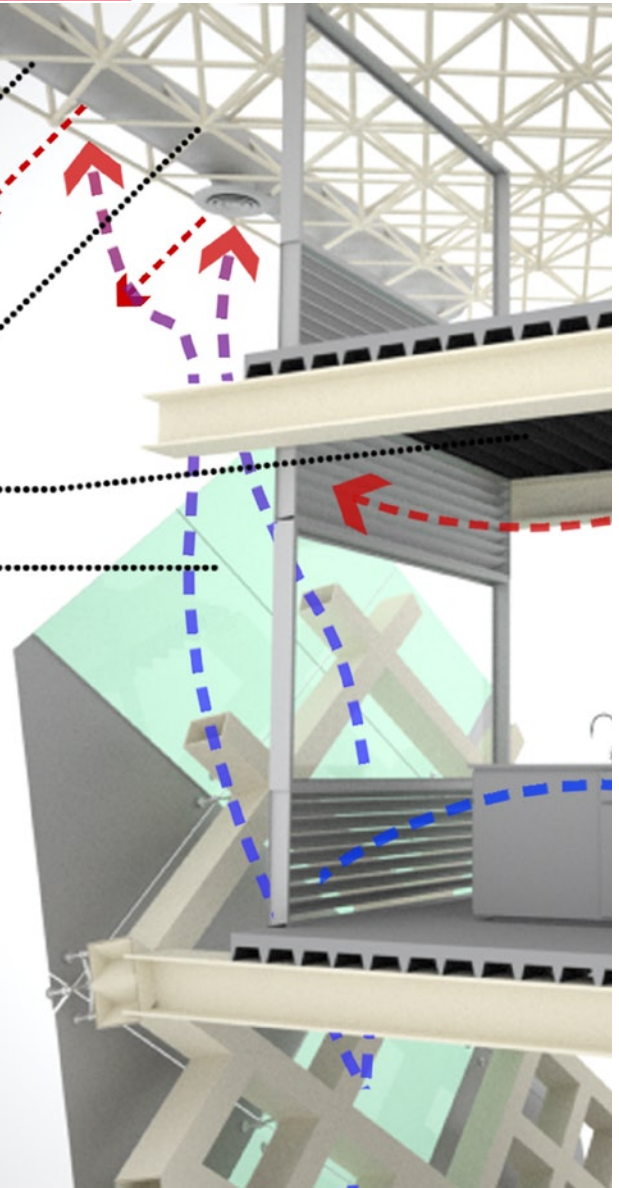

Figure 7.40: Hybrid passive ventilation components



7.4.2 Daylighting (Visual, Thermal)

Natural daylight is psychologically important in buildings, it boosts occupants' mood and creates a more habitable environment. It is a free and natural source of energy and lighting that has been used as an integral part of the lighting design in the facility. Further, it dovetails very well with the passive ventilation strategy of the facility.

Research facilities have very specific Daylighting requirements including:

- As much natural light as possible
- Views for users and researchers
- Minimal direct lighting and glare
- Minimal heat gain

To address these requirements, the facility is designed with the following Daylighting strategies to achieve optimal working conditions for the users of the facility. See diagrams

1. The surface of the facility is angled and undulates between 9 and 18° (See figures 43-45)
2. The use of solar shading devices where required, including aluminium facade cladding panels and lattice structure (See figure 38)

3. Orientation, the facility is orientated as close to North as possible. The facility is turned 31 degrees from true north due to site constraints (visual arts sun requirements) and design requirements (views, axis and context). This exposes the southern facade to westerly summer sun from 16:00 pm in the afternoon. (f.46-49)

4. The use of an optimised glazing strategy, this includes the use of Smart glass Coolvue clear on the envelope (Visible light transmission - 72%, 53% solar energy elimination and 99% UV ray block). Smart glass Solarshield S30 (Visible light transmission - 29%, 59% solar energy elimination and 99% UV ray block) on all glazed atrium areas (See figures 41,42)

The Daylighting system works in a symbiotic relationship with the proposed passive ventilation strategy.

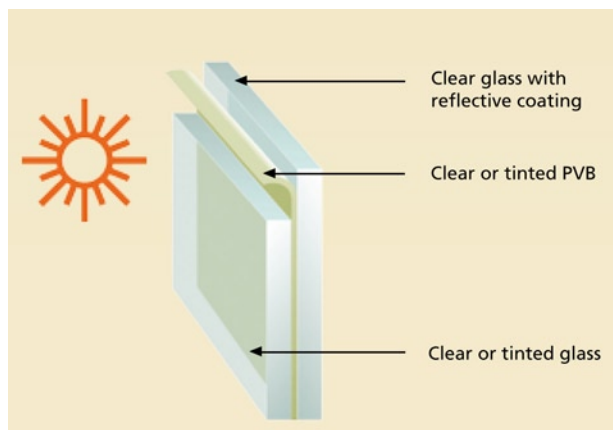

Figure 7.41: Smart glass Solarvue components

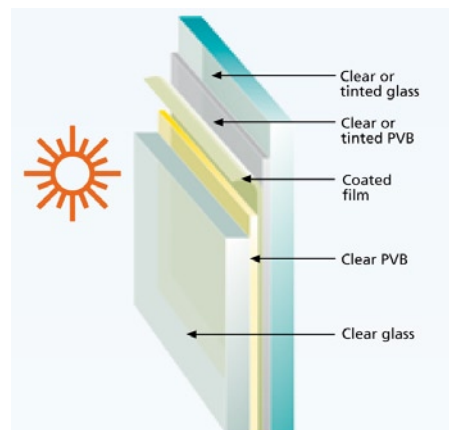

Figure 7.42: Smart glass Coolvue components

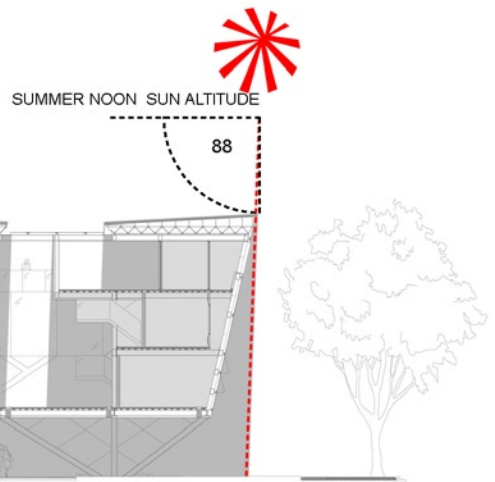

Figure 7.43: Summer noon solar incidence angle

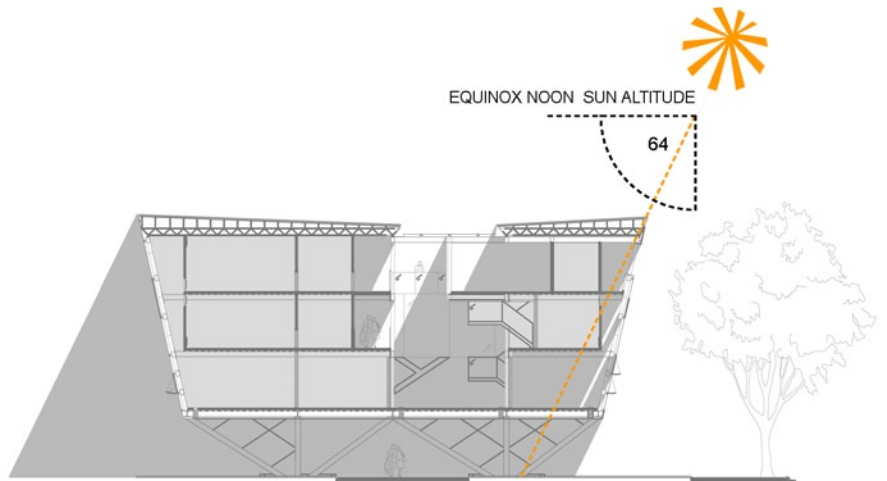

Figure 7.44: Equinox noon solar incidence angle

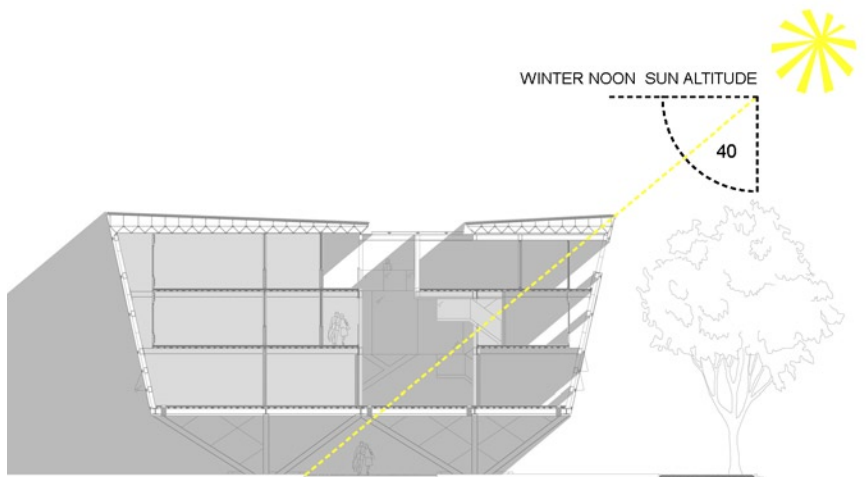
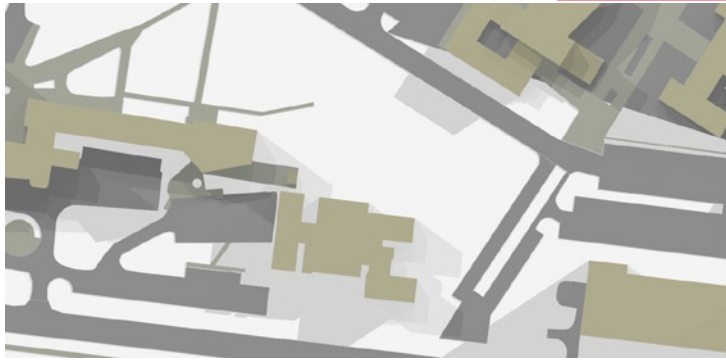

Figure 7.45: Winter noon solar incidence angle





- Site in winter shows good exposure to northern sun. Visual arts department needs to be considered to prevent obstruction of northern sun

Figure 7.46: Winter shadow analysis on site before intervention

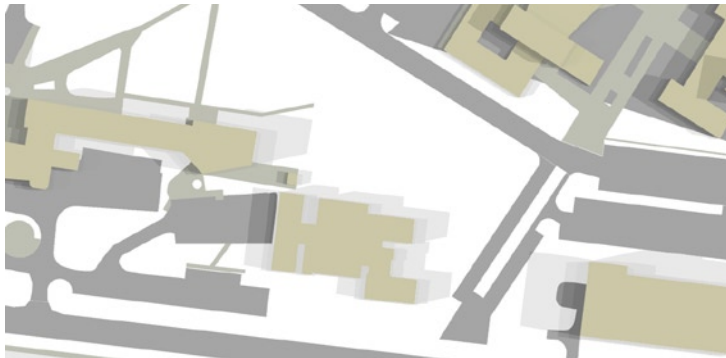

- Site in summer shadow analysis indicates that western afternoon sun might create thermal control issues

Figure 7.47: Summer shadow analysis on site before intervention

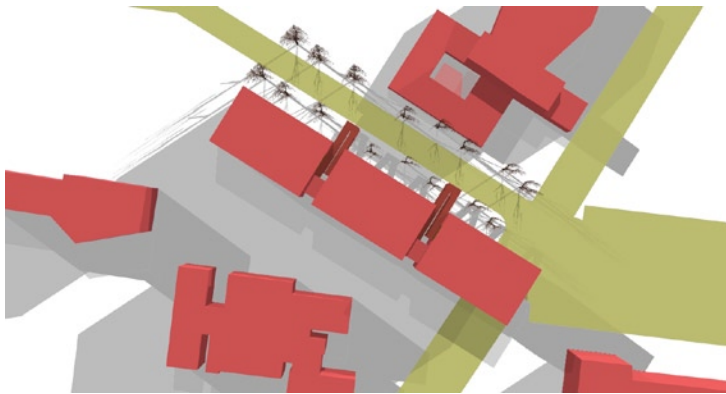

- Proposal winter shadow analysis indicates no obstruction of neighbours northern sun exposure. Project receives good winter sun to northern facade

Figure 7.48: Winter shadow analysis after intervention



- Proposal summer shadow analysis indicates that preventative measures need to be employed on western facade to guard against afternoon sun from 16:00 pm. The atrium glazing will also require special attention

Figure 7.49: Summer shadow analysis after intervention

7.5 Storm water Management

Storm water disposal from the facilities roof structure is done in accordance with SABS 0400 building regulations with special attention to sections RR2 and RR3. All calculations as shown in figure 50 are done in accordance it he section RR3.1 and RR3.2. Storm water run off is collected from the roofs surface to main drainage gutters, transported to downpipes and from there to a storage tank system. As is discussed in section 7.9 of this chapter the water will be used for landscape irrigation purposes.

Due to the internal location of the gutters the system is fitted with over-flows at regular intervals to prevent infiltration in to the building when critical drainage levels are exceeded.

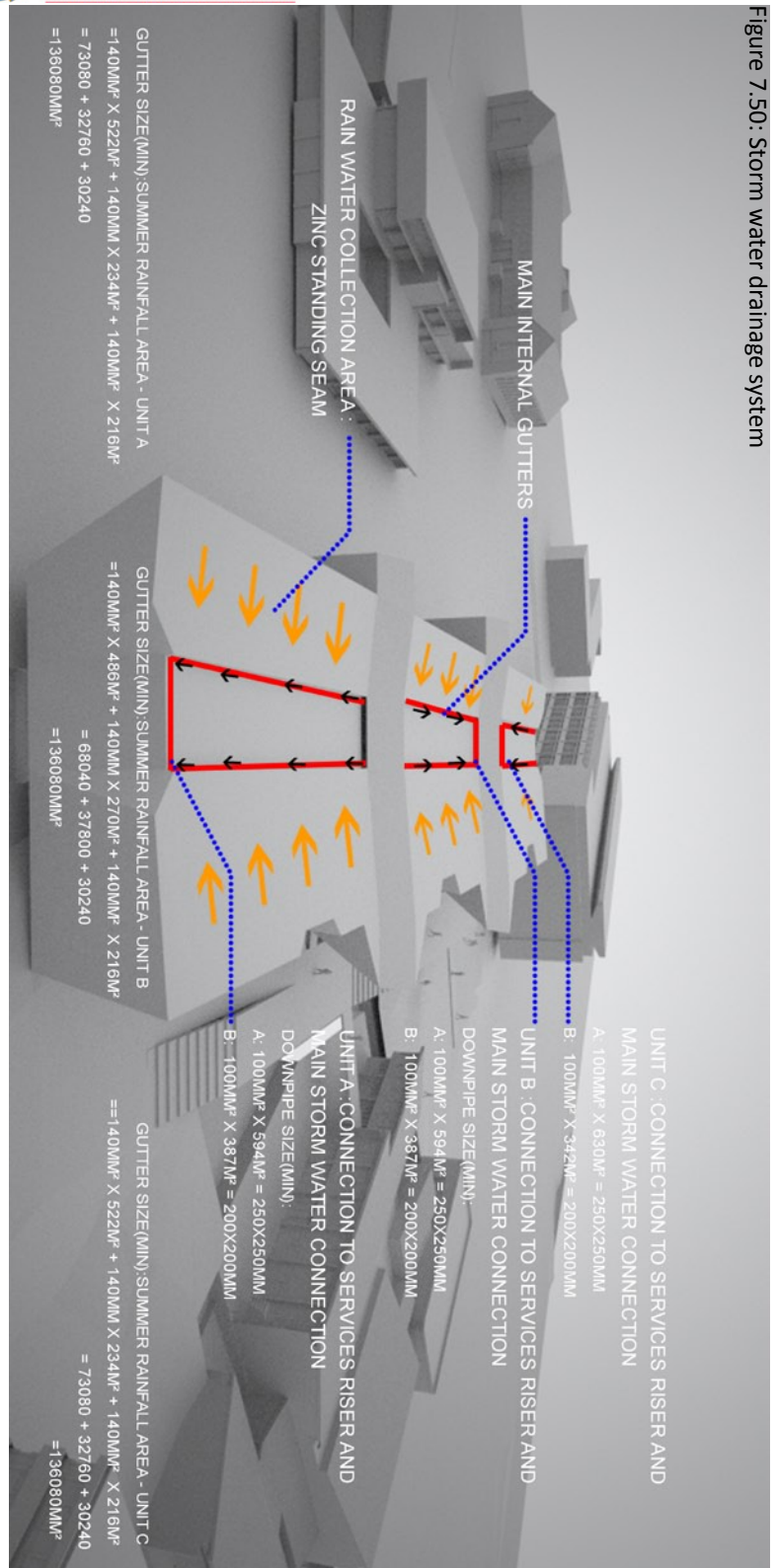

Figure 7.50: Storm water drainage system



7.6 Materials

Architectural surface has a particular significance when material and finishes choice are investigated. Choosing materials that embody the theory of deep surface and allow its manifestation is of utmost importance in this facility. Furthermore, being a research facility the materials pallet was also informed by strict performance criteria in terms of durability, chemical and fire resistance. While keeping these strict parameters in mind it was very important to

make materials selections that lend themselves to the establishment of inspiring environments. The overriding parameter that was kept in mind throughout the materials selection and design process was that of sustainability. Materials selection and design are not two separate fields of practice but need to be an integral process to achieve truly innovative results.

6.6.1 Materials Pallet

6.6.1.1 Structural Elements

Structural Steel

Mild steel members were chosen for the structure due to the intricate and complicated nature of the structural system. It provides an ease of construction that would not be achieved by using reinforced concrete on the specific structure. The second reason that a steel structure was chosen was for aesthetic reasons, to achieve a slim and light structure; a structure system that is flexible and allows open and transparent spatial contexts to be evoked without the need for internal supports.



Figure 7 51: OMA's Seattle library steel structure

Reinforced Concrete

Concrete is used sparingly throughout the elevated structure of the facility and is only used where required for the structural bearing elements such as floor slabs and foundation pads.



Figure 7.52: Concrete

Composite Floor Deck

The galvanised mild steel floor deck system that is employed in the facility was chosen for functional reasons. Firstly the ease of construction, that comes with the sacrificial shutter system of the composite slab. Secondly the slim depth of the slab allows the accommodation of services required in a research facility and allows greater floor to ceiling heights. Lastly the slim nature of the deck helps to lighten the structure of the facility.

Space Frame Roof Structure

As discussed earlier in this chapter in more detail the space frame structure was chosen for its relative long span to depth ratio and light weight structure. The proposed finish to the space frame is a powder coat finish to match the rest of the steel structure.

Pilkington's Planar Glazing System

This point fixed glazing system was chosen as it allows the creation of flush frame less facade elements. The fittings are manufactured in 316 stainless steel. Secondly it lends its self to the creation of complex surface shapes.

6.6.1.2 Envelope (Epi-Surface)

Glazing

Glass forms a major part of the external envelope system. It is employed due to its blank canvas properties, becoming a reflective pallet for the surrounding environment as well permitting views in to and out of the structure. The glass that was chosen is the Smart Glass Coolvue product, it was consciously chosen as part of the climate control strategy.



Figure 7.53: Composite floor slab



Figure 7.54: Space frame structure



Figure 7.55: Pilkingtons planar glazing system



Figure 7.56: Smart glass coolvue glass



Composite Aluminium Cladding



Figure 7.57: Composite aluminium cladding panels

As with previous material choices, thermal and aesthetic concerns influence the selection of the product for the external facade. The panel provides a blank canvas that allows the environment to ‘paint’ on the facade of the building as times of day and seasons change. It has great thermal performance and is light weight and has good weathering resistance. It consists of two 0.5mm aluminium skin laminated to a mineral insulation core to create a rigid panel.



Figure 7.58: Zinc standing seam roof cladding

Zinc Standing Seam roof cladding

This roof cladding system was chosen to facilitate a ‘seamless’ transition from the facade surface to the roof surface. As well as the system’s ability to conform to complicated forms, its excellent weather proofing and longevity.

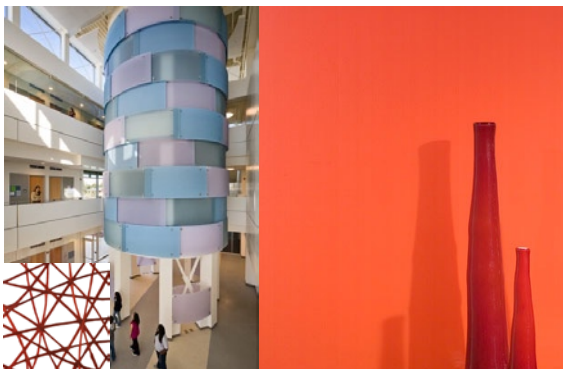

Figure 7.59: Ecoresin cladding panels

6.6.1.3 Finishes

Resin cladding panels

The resin panels chosen to clad the interior ‘tube’ structures was chosen due to its aesthetic qualities of colour, light transmission and vibrancy. It will be used to create unique interior characters in each of the research units. It is also a sustainable material that consists of 40% post industrial recycled materials and is itself recyclable at the end of its life.



Figure 7.60: Epoxy resin floor finish

Epoxy Resin Floor Finishes

Chemical resistance non permeability is an imperative for research facility floors. The epoxy resin floor finish adheres to these strict requirements, as well as affords the opportunity to introduce colour in to the usually sterile research environments.

Lighting

Lighting plays an integral part of the facilities design and development. An LED colour cycling flood light system will be employed on the external surface from the interior. This will illuminate the building at night and make it a focal point in the campus landscape. Recessed lighting details are incorporated behind the eco resin cladding panels on each of the tubes to create a unique glowing effect.

Other lighting details throughout the facility are to be in keeping with the investigation of Deep surface and architectural surface. The use of recessed light fittings and custom edge lighting details will be employed to achieve this effect.

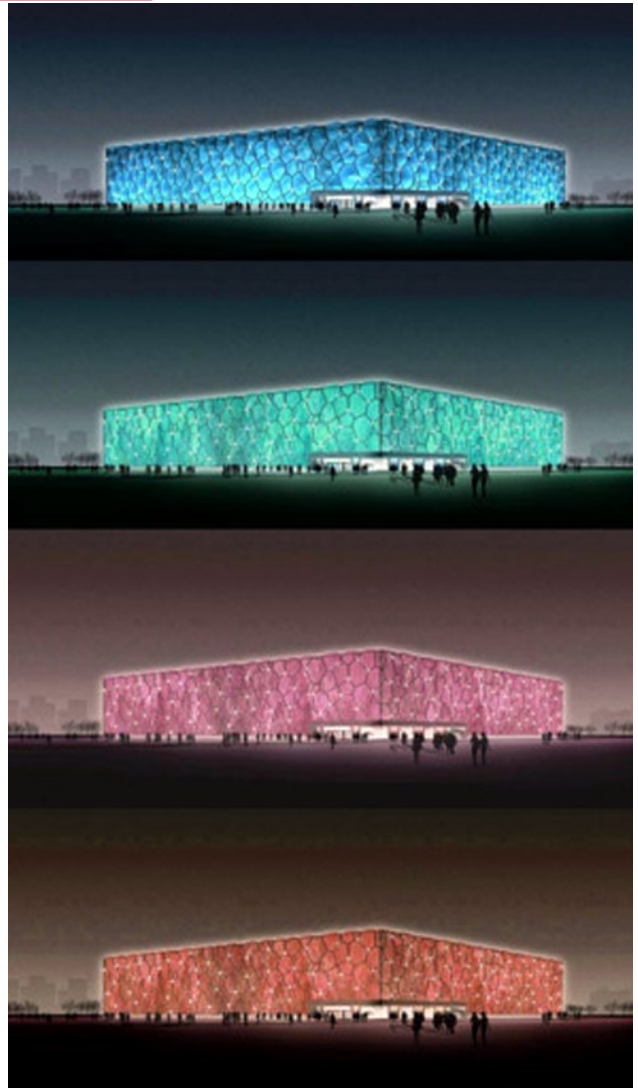

Figure 7.61: RGB LED facade lighting

Figure 7.62: LED facade lighting systems



7.7 Services Design

The design of the services supply system in a research facility is of great importance and requires careful planning to ensure the optimal performance and flexibility for future change and growth. (Griffin, 2005)

The main services that need to be looked at include:

- Water- supply, storage and treatment
- Electric supply
- Gas supply and storage
- HVAC systems
- Fire detection and treatment

6.8.1 SANITARY, PLUMBING AND DRAINAGE

The design of drainage and sanitary services in a research facility is a highly technical exercise that needs to be undertaken by specialist services engineers; however the following are general guidelines to achieve satisfactory results. Sanitary, plumbing and drainage facilities that: (Griffin, 2005)

- Can accommodate the modular laboratory arrangement
- Do not require venting through upper floors for the addition of isolated fixtures
- Complies with the relevant standards
- Is cost effective
- Has the option to be installed in multilevel facilities and can accommodate additional levels
- Is constructed out of materials that are easily re configured
- Is designed to act in insulation of the municipal water supply to prevent contamination
- Has a waste water treatment plan.

6.8.2 WATER SYSTEMS

Once again water systems in research facility are much more complex than that of the standard building requiring specific design and planning some of the main issues to keep in mind include: (Griffin, 2005)

The reticulated water supply for a research building comprises three types:

1. Potable (Hot and Cold)
2. Non-potable (Hot & Cold)
3. Analytical grade (Hot & Cold)

Each water supply system outlet is fitted with a flow control device to:

Conserve water, eliminate water hammer, provide reliable and predictable flow control at the tap and allow consistent tapware throughout the facility.

6.8.3 AIR HANDLING SYSTEMS

Air handling systems need to provide to the main functions effectively and efficiently this includes air quality and Thermal control. (Griffin, 2005)

6.8.4 ELECTRICAL SUPPLY

The power supply for a laboratory environment should consist of the following elements (Griffin, 2005)

- Properly rated and protected incoming supply;
- Spare capacity for system expansion and peak loading;
- Flexible reticulation systems to ensure maximum usage of laboratory space; and
- The use of backup power supplies such as diesel generators and interruptible power supplies to enable basic operation of the facility during a power failure.

6.8.5 SERVICES SUPPLY

Services main supply runs are to take place in the peristitial cavity of the deep surface with branches to a unit strut ceiling grid system. The branches supply flexible connection point in the lab @ 3000mm centres, thus 24 flexible connection points per lab. This system allows the most adaptable services supply solution for an ever evolving facility. (Griffin, 2005)

7.8 Codes and Standards

The major construction and structural works that are to be undertaken on this project needs to conform to the relevant statutory requirements as well as the building codes and standards.

The three major structural systems in the facility comprise steel work, glasswork and reinforced concrete. The following are the relevant standards for the above mentioned systems to adhere to:

STEELWORK

- SABS 1431 - Weldable structural steel
- SABS 044 - Welding
- SABS 064 - Preparation of steel surfaces for coating
- SABS 14713 - Structural steel component design
- SABS 0400 - Fire protection of steel work
- SABS 1319 - Paint primer
- SABS 684 Structural steel paint
- SABS 1700 - Fasteners
- SABS 1282 - High strength bolts, nuts and washers

GLASSWORK

- SABS 1263 - Safety glazing materials
- SABS 1305 - sealing compounds silicone based
- SABS 0137 - Installation of glazing materials

REINFORCED CONCRETE

- SABS 1083 - Aggregates for concrete
- SABS 0109 - Concrete floors part 1 & 2
- SABS 0161 - Design of foundations for buildings
- SABS 0100 - Structural use of concrete
- SABS 920 - Steel bars for reinforcement of concrete

7.9 Sustainable Parameters

Sustainable design has been the buzz word in architecture in recent years. However I believe it is no longer just a buzz word or the topic of the moment, it has become an integral part of architectural design and the key performance criteria for contemporary design.

Further to this statement I would not have included a section on sustainable design in this study if it were not of utmost importance in the design of my building. Research laboratories use 5 to 10 more resources than a office building of the same size. Hence sustainability is a key component in the design of a new research facility for the university, and was a key indicator in all design decisions.

Designing a sustainable research facility requires the implementation and adherence to five key performance criteria; Site and Context, Energy Efficiency, Water Management, Materials and Design. Each of the above mentioned areas of concern played a major role in the development of my research laboratory.

Most of the above mentioned criteria have been discussed in previous chapters without making direct reference to a sustainable strategy, the following sections will set out the sustainable performance criteria and strategies as employed in the research laboratory

7.9.1 Site and Context

Numerous site and contextual parameters are discussed earlier in this chapter, other influencing factors for the site selection include:

- The location of the site close to public transport
- The accessibility of the site by pedestrians on campus.
- Provision of bicycle storage facilities on the site.





7.9.2 Energy Efficiency

Energy efficiency is determined by various components of the design, including climate control, orientation, daylighting and appliances.

The key indicators focussed on the design include:

A. Daylighting, with a focus on maximizing northern exposure, enhanced daylighting with minimal glare as discussed in section 7.4.2 of this chapter.

B. Climate control with a focus on passive systems as set out in section 7.4.1.

C. The implementation of a Building Management System, that can control the indoor building environment. The BMS system will focus to a greater extent on the passive ventilation system and lighting, with the implementation of lighting sensors and automatic dimming in all spaces.

D. Energy efficient appliances are to be used throughout the facility.

E. The implementation of passive energy systems such as solar water heaters to all common areas including bathrooms and kitchens.

7.9.3 Water Management

Water conservation is of grave importance in our country, along with the water management protocols and systems as set out in sections 6.8.1, 6.8.2 and 7.5 the following systems are to be implemented in the research facility:

A. All bathroom and laboratory water supply fittings are to be fitted with low flow fittings.

B. All Urinals in the facility are to be waterless

C. Toilets are to be dual flush(3L&6L).

7.9.4 Materials

Where possible all materials should be from local manufactures and sources, materials should be recyclable and contribute to a healthy and low embodied energy interior environment.

7.9.5 Design

Design plays an unmistakable role in the sustainability of a research facility, it depends on two characteristics two achieve a stainable rating; Structure and Space.

A. Spatially the facility is designed to be as adaptable and flexible as possible, to accommodate future changes in spatial requirements and technological advancements as discussed in section 7.1,2,3 and chapter 6.

B. Structurally the facility provides the conditions of flexibility and adaptability mentioned above. Secondly the structure of the building is design to facilitate ease of deconstruction at the end of its life.



UNIVERSITEIT VAN PRETORIA
UNIVERSITY OF PRETORIA
YUNIBESITHI YA PRETORIA





| | | |
|---|---------------------|---|
| | APPENDICES | |
| + | | + |
| | URBAN ANALYSIS 8.1 | |
| | LIST OF FIGURES 8.2 | |
| | REFERENCES 8.3 | |

8.1 Urban Analysis

The following figures 8.1-8 represent the rest of the urban grain analysis as set out in chapter three of the Document. The analysis as stated previously is done at the hand of numerous performance criteria as detailed in chapter three.

The Summary of the complete analysis can be seen in figure 3.17 as a representational diagram of a city blocks urban performance.



Figure 8.1: Height and Massing analysis



Figure 8.2: Urban Structure analysis



Figure 8.4: Streetscapes and landscapes

Figure 8.3: Urban Grain analysis



Figure 8.5: Facade and Interface analysis





Figure 8.6: Adaptability analysis



Figure 8.7: Quality of the public realm analysis

Figure 8.8: Legibility analysis



List of Figures

1 Brief

- | | | |
|-----|---|--|
| 1.1 | Design development section through facility, landscape and circulation (Author) | (Author) |
| 1.2 | Concept sketch of lab surface interface (Author) | 2.23 Current site use aerial photograph (Mr.SidGEO View) |
| 1.3 | Design development section through central connective atrium (Author) | 2.24 Public transport surrounding campus diagram (Author) |
| | | 2.25 Site climate analysis diagram (Author) |
| | | 2.26 Panorama of Southern neighbour (Visual Arts) (Author) |

2 Context

- | | | |
|------|--|---|
| 2.1 | Regional scale location diagram (Author) | 2.27 Panorama of eastern neighbour (Boukunde) (Author) |
| 2.2 | Regional scale areal photograph (Mr.SidGEO View) | 2.28 Panorama of Norther neighbour (Music Department) (Author) |
| 2.3 | Metropolitan scale areal photograph (Mr.SidGEO View) | 2.29 Site location diagram (Author) |
| 2.4 | Precinct scale areal photograph (Mr.SidGEO View) | 2.30 Panorama of Fever tree lane (Author) |
| 2.5 | Metropolitan scale location diagram (Author) | 2.31 Diagram showing neighbouring site features (Author) |
| 2.6 | 1921 Campus Development (A.D Destinatium) | 2.32 Photograph of Boukunde`s Western facade (Author) |
| 2.7 | 1943 Campus Development (A.D Destinatium) | 2.33 Photograph of Boukunde`s Northern facade (Author) |
| 2.8 | 1960 Campus Development (A.D Destinatium) | 2.34 Boukunde location diagram (Author) |
| 2.9 | 1970 Campus Development (A.D Destinatium) | 2.35 Visual arts location diagram (Author) |
| 2.10 | 1982 Campus Development (A.D Destinatium) | 2.36 Photograph of Visual Arts main entrance (Author) |
| 2.11 | Educational soft open spaces (Author) | 2.37 Photograph of Visual Arts` NE corner (Author) |
| 2.12 | Functional soft open spaces (Author) | 2.38 Photograph of Administration Northern facade (Author) |
| 2.13 | Buffer soft open spaces (Author) | 2.39 Aerial photograph of the Administration building (A.D Destinatium) |
| 2.14 | Hard open space structure (Author) | 2.40 Administration location diagram (Author) |
| 2.15 | Campus figure ground study (Author) | 2.41 Musaion location diagram (Author) |
| 2.16 | Campus soft open space structure (Author) | 2.42 Photograph of Musaion main entrance (Author) |
| 2.17 | Campus building use study (Author) | 2.43 Photograph of Musaion Western facade (Author) |
| 2.18 | Campus possible development sites (Author) | 2.44 Site access and movement analysis sketch diagram (Author) |
| 2.19 | Campus circulation and axis study (Author) | 2.45 Site views diagram (Author) |
| 2.20 | Site location diagram (Author) | 2.46 Panorama of main Tukkies laan and ring road intersection (Author) |
| 2.21 | Site and Precinct location diagram (Author) | |
| 2.22 | Site surround development potential diagram | |



| | | | |
|----------------|--|----------|---|
| 2.47 | National Research context diagram (Author) | 3.16 | Analysis area (Group Work) |
| 2.48 | Regional Research context diagram (Author) | 3.17 | Campus urban performance analysis avareges (Author) |
| 2.49 | International Research context diagram (Author) | 3.18 | Character analysis (Group Work) |
| 2.50 | Argiculture research storage and wash area analysis diagram (Author) | 3.19 | Details and Materials analysis (Group Work) |
| 2.51 | Natural sciences research lab analysis diagram (Author) | 3.20 | Continuity and Enclosure analysis (Group Work) |
| 2.52 | New Fabi research Lab analysis diagram (Author) | 3.21 | Diversity analysis (Group Work) |
| 2.53 | Engineering research lab write up area analysis diagram (Author) | 3.22 | Density and Mix analysis (Group Work) |
| 2.54 | Engineering research lab analysis diagram (Author) | 3.23 | Ease of Movement analysis (Group Work) |
| | | 3.24 | Initial Interventions map (Group Work) |
| | | 3.25 | Urban fabric devision process (CABE, 2006) |
| | | 3.26 | Pedestrian friendly sidewalk set out (CABE, 2006) |
| | | 3.27 | Pedestrian spatial requirements (CABE, 2006) |
| | | 3.28 | Pedestrian sidewalk boundary scale (Office of the Deputy Prime Minister, 1998) |
| | | 3.29 | Proposed ringroad, parking and pedestrian zone (Office of the Deputy Prime Minister,1998) |
| | | 3.30 | Pedestrian line of sight requirements (Office of the Deputy Prime Minister, 1998) |
| | | 3.31 | Basic street width to height ratios (Office of the Deputy Prime Minister, 1998) |
| | | 3.32 | Ringroad intersection proposed raised junctions (Office of the Deputy Prime Minister, 1998) |
| | | 3.33 | Strategic interventions diagram (Group Work) |
| | | 3.34 | Key interventions diagram (Group Work) |
| 3 Urban Design | | 4 Theory | |
| 3.1 | Campus outdoor rooms diagram (Loebl Schlossman & Hackl) | 4.1 | Mies van der Rohe`s Farnsworth house (Welch, A) |
| 3.2 | Campus architectural character (Loebl Schlossman & Hackl) | 4.2 | Mies van der Rohe`s Farnsworth house (Welch, A) |
| 3.3 | Nighttime campus lighting (Loebl Schlossman & Hackl) | 4.3 | Mies van der Rohe`s Farnsworth house (Welch, A) |
| 3.4 | Campus as a village (Loebl Schlossman & Hackl) | | |
| 3.5 | Campus main entrances (Loebl Schlossman & Hackl) | | |
| 3.6 | Campus must be a safe environment (Loebl Schlossman & Hackl) | | |
| 3.7 | Campus circulation to separate cars and pedestrians (Loebl Schlossman & Hackl) | | |
| 3.8 | Paths (Author) | | |
| 3.9 | Node (Author) | | |
| 3.10 | Edges (Author) | | |
| 3.11 | Landmarks (Author) | | |
| 3.12 | Districts (Author) | | |
| 3.13 | Overview of campus districts (Group Work) | | |
| 3.14 | Campus image and opportunities analysis (Group Work) | | |
| 3.15 | Campus development potential analysis (Group Work) | | |



- | | | |
|------|--|--|
| 4.4 | Hans Hollein's Abteiberg Museum (Schaefer, H.P) | Boeringer Lab. (Sauerbruch Hutton) |
| 4.5 | Michael Graves' Portland Public Service Building (Refocus) | 5.11 Photograph of an interactional space in the Boeringer Lab (Sauerbruch Hutton) |
| 4.6 | Charles Willard Moore's Piazza d'Italia (Lockley,W) | 5.12-14 Photograph of the glass louvre facade at the Boeringer Ingleheim Pharmasuetical Research Lab (Sauerbruch Hutton) |
| 4.7 | Kas Oosterhuis surface explorations (Kas Oossterhuis) | 5.15 Boeringer research facility FF plan (Sauerbruch Hutton) |
| 4.8 | Kas Oosterhuis surface explorations (Kas Oossterhuis) | 5.16 Photograph of the Clark center central courtyard (Foster and Partners) |
| 4.9 | Kas Oosterhuis surface explorations (Kas Oossterhuis) | 5.17-19 Photographs of the internal court yard at the Clark Centre (Foster and Partners) |
| 4.10 | Kas Oosterhuis surface explorations (Kas Oossterhuis) | 5.20-22 Clark Centre internal spaces (Foster and Partners) |
| 4.11 | International student (Mustav Hamdy) surface exploration | 5.23 Section Through the Clark Centre (Foster and Partners) |
| 4.12 | International student (Mustav Hamdy) surface exploration | 5.24 Blizzard building atrium view, showing pods and research space (Kiser, K. 2005) |
| 4.13 | International student (Mustav Hamdy) surface exploration | 5.25 Internal view in one of the pods in the blizzard building (Kiser, K. 2005) |

5 Precedents Studies

- | | | |
|-------|--|---|
| 5.1 | Internal circulation void of the Life Sciences building (Structural Concrete Industries, 2002) | 5.26 Photograph of the external glass facade (Kiser, K. 2005) |
| 5.2-3 | Photos of the external facade of the life sciences building (Structural Concrete Industries, 2002) | 5.27 Photograph of mezzanine level circulation in the blizzard building (Kiser, K. 2005) |
| 5.4 | View of lecture hall in the life sciences building (Structural Concrete Industries, 2002) | 5.28 Photograph of the external glass facade and connecting bridge (Kiser, K. 2005) |
| 5.5-6 | Photos of the external facade of the life sciences building (Structural Concrete Industries, 2002) | 5.29 Photograph of atrium pods and research space (Kiser, K. 2005) |
| 5.7 | First floor plan of the NSW Life Sciences research facility (Structural Concrete Industries, 2002) | 5.30 Photograph of atrium pods and research space (Kiser, K. 2005) |
| 5.8 | Photograph of the glass louvre facade at the Boeringer Ingleheim Pharmasuetical Research Lab (Sauerbruch Hutton) | 5.31 Night time Photograph of the exterior of the Prada store (Glynn, S. 2005) |
| 5.9 | Photograph of the glass louvre facade at the Boeringer Ingleheim Pharmasuetical Research Lab (Sauerbruch Hutton) | 5.32 Section drawing of the Prada store (Glynn, S. 2005) |
| 5.10 | Photograph of the circulation void in the | 5.33 Design model of the Prade store (Glynn, S. 2005) |
| | | 5.34 Photograph of the interior of the Prada store (Glynn, S. 2005) |
| | | 5.35-39 Photographs of the rhomboid lattice structure of the prada store (Glynn, S. 2005) |
| | | 5.40 Section drawing of the Prada store (Glynn, S. 2005) |
| | | 5.41-43 Photographs of the Prada store (Glynn, S. 2005) |
| | | 5.44 Photograph of the facade of the seattle |





| | |
|---|---|
| library (Kiser, K. 2008) | 6.45-47 Focal point views as part of formal development (Author) |
| 5.45-47 Photograph of the lattice structure of the seattle library (Kiser, K. 2008) | 6.48 Massing Diagram Indicating main views and axis (Author) |
| 5.48-49 Construction details for the Seattle library lattice structure (Kiser, K. 2008) | 6.49 Conceptual massing diagram indicating main entrances (Author) |
| 5.50 Construction details for the Seattle library lattice structure (Kiser, K. 2008) | 6.50 Conceptual massing diagram indicating Transition Zones (Author) |
| 5.51 Interior view of the Seattle library common space (Kiser, K. 2008) | 6.51 Conceptual massing diagram indicating connecting atrium axis (Author) |
| 5.52 Photograph of the lattice structure of the Seattle library (Kiser, K. 2008) | 6.52 Combination of view determined formal development (Author) |
| 5.53 Conceptual context rendering of the Autolith design proposal (Serero Architects) | 6.53 Initial Walkway concept (Author) |
| 5.54-57 Conceptual projects renderings of the proposed Serero Autolith design (Serero Architects) | 6.54 Conceptual walkway rendering (Author) |
| | 6.55 Walkway from boukunde (Author) |
| | 6.56 Walkway from main intersection (Author) |
| | 6.57 Preliminary final circulation concept (Author) |
| | 6.58 Final Conceptual model of circulation system (Author) |
| | 6.59 Sketch investigating main entrance and circulation relationship (Author) |
| | 6.60 Perspective artistic impression of one of the proposed atrium zone with all its connective and interactional devices. (Author) |
| 6 Design Investigation | 6.61 Perspective artistic impression of one the proposed atrium zone showing the vertical link between structure and space in the atrium zones, as well as daylight penetration at midday in the summer. (Author) |
| 6.1 Study of people in landscape as source of light (Author) | 6.62 Perspective artistic impression of one of the proposed atrium zones from the upper laboratory circulations space. (Author) |
| 6.2 Analogue Generative process A (Author) | 6.63 Perspective artistic impression illustrating the interior of the long connective tube (Author) |
| 6.3 Conceptual facade studies from analogue generation process (Author) | 6.64 Perspective artistic impression illustrating the view of the transitions zone with vertical circulation in the atrium. (Author) |
| 6.7 Analogue Generative process B (Author) | 6.65 Perspective artistic impression from the proposed transition zone at second floor level in to the atrium. (Author) |
| 6.8-11 Contextual facade studies from analogue generation process B (Author) | 6.66 Perspective artistic impression illustrating the view of the atrium as it will be experienced when entering the research |
| 6.12-16 Structural development studies (Author) | |
| 6.17-20 Structural development studies (Author) | |
| 6.21-24 Structural development studies (Author) | |
| 6.25-29 Structural development studies (Author) | |
| 6.30-31 Deep surface tubes spatial exploration (Author) | |
| 6.32 Initial conceptual rendering of Deep Surface (Author) | |
| 6.33-34 Break out spaces exploration (Author) | |
| 6.35-36 Conceptual spatial study of atrium (Author) | |
| 6.37 Aerial view of deep surface tubes (Author) | |
| 6.38-39 Deep Surface spatial study (Author) | |
| 6.40 View of quadruple volume atrium and spatial exploration | |
| 6.41 Conceptual view from deep surface (Author) | |
| 6.42-44 Focal point views as part of formal development (Author) | |



- 7.56 Smart glass coolvue glass (P.G Smart Glass)
- 7.57 Composite aluminium cladding panels
- 7.58 Zinc standing seam roof cladding
- 7.59 Ecoresin cladding panels
- 7.60 Epoxy resin floor finish
- 7.61 RGB LED facade lighting
- 7.62 LED facade lighting systems

8 Appendices

- 8.1 Height and Massing analysis (Group Work)
- 8.2 Urban Structure analysis (Group Work)
- 8.3 Urban Grain analysis (Group Work)
- 8.4 Streetscapes and landscapes (Group Work)
- 8.5 Facade and Interface analysis (Group Work)
- 8.6 Adaptability analysis (Group Work)
- 8.7 Quality of the public realm analysis (Group Work)
- 8.8 Legibility analysis (Group Work)

8.5 References

- Arendt, H. 1958. *The Human Condition*. Chicago: The University of Chicago Press.
- Burtzig, W. 2008. Personal Interview. 01 August. Pretoria
- Burtzig, W. 2008. Personal Interview. 05 September. Pretoria
- Burtzig, W. 2008. Personal Interview. 30 September. Pretoria
- Commission For the Built Environment. 2006. *The Value Handbook, getting the most from your buildings and spaces*. London: CABI
- Department of Transport, 2007. *Manual for streets*. London: Thomas Telford Publishing
- Foster and Partners, 2003. Clark Center, Stanford University, Available: <http://www.fosterandpartners.com/Projects/1076/Default.aspx> [02/10/2008]
- Frei, H. 2003. Masked matter and other diagrams. In Taylor, M. *Surface Consciousness*, 44-47. London: Wiley Academy
- Glynn, S. 2005. Prada Store (Epicenter), Available: <http://www.galinsky.com/buildings/pradatokyo/index.htm> [14/08/2008]
- Goldstein, R. N. 2006. *Architectural Design and the Collaborative Research Environment*: Boston, MA 02116, USA: Goody Clancy
- G.P Greef and Associates. 1999. UP Riglyn Plan 2000.
- Griffin, B. 2005. *Laboratory design guide*. Oxford, United Kingdom: Architectural Press.
- Kiser, K. 2005. Alsop Design/AMEC Blizzard Building Queen Mary University London, UK, Available: <http://www.arcspace.com/architects/alsop/blizard/blizard.html> [17/07/2008]
- Kiser, K. 2008. Rem Koolhaas OMA Seattle Public Library Seattle, Washington, Available: <http://www.arcspace.com/architects/koolhaas/Seattle/> [17/07/2008]
- Lynch, K. 1982. *The Image of the city*. Cambridge: The MIT Press
- Macdonald, J. 1998. *Structural design for architects*. Oxford, United Kingdom: Architectural Press.
- Napier, A. 2000. *Enviro-Friendly Methods in small building design for South Africa*. Pretoria: Napier, A.
- Office of the Deputy Prime Minister, 1998. *Places, Streets and Movement*. London: *Queen's Printer and Controller of Her Majesty's Stationery Office*.
- Potgieter, D. 2008. Personal Interview. 31 March. Pretoria
- Refocus. 2002. *Walking Portland*, Available: <http://www.onfocus.com/cam/2002/portland/index.asp?p=5> [22/10/08]

- Sacramento Transportation and Air Quality Collaborative, 2004. Urban design is, Available: <http://students.ou.edu/H/Antonia.G.Hoberecht-1/IntroToUrbanDesign.html> [29/09/2008]
- Schoeman, C. 2008. Personal Interview. 06 October. Pretoria
- Serero Architects. 2007. AUTOLITH, Available: http://www.serero.com/index_en.htm [03/10/2008]
- Stern, R. 1977 . At the edge of Modernism. Architectural design, vol. 47 , no 4.
- Structural Concrete Industries, 2002. Award for Outstanding Structures: Life Sciences Building University of Newcastle. Sydney: Structural Concrete Industries
- Taylor, M. 2003. *Surface Consciousness*. London: Wiley Academy
- The Government of the Republic of South Africa. 2002. South Africa's National Research and Development Strategy. Pretoria: Department of Science and Technology
- The Urban Design Group, 2003. What is urban design?, Available: http://www.udg.org.uk/?document_id=468 [29/09/2008]
- UN Studios, 2007. After Image: Huazhong University: Huazhong University of science and technology press.
- University of Pretoria. 2007. Innovation Generation: Creating the Future, 2007–2011, The Strategic Plan of the University of Pretoria, Available: <http://web.up.ac.za> [05/03/2008]
- University of Pretoria. 2007. University of Pretoria Centenary, Available <http://web.up.ac.za/default.asp?ipkCategoryID=5035> [26/09/2008]
- Van Patter, G.K. 2003. What Matters?. New York: NextDesign Leadership Institute
- Webometrics. 2008. Catalogue of World Universities: Universities of South Africa, Available: http://www.webometrics.info/rank_by_country.asp?country=za [07/03/2008]
- Webometrics. 2008. Catalogue World Universities' ranking on the Web: Top 1000 R&D, Available: http://www.webometrics.info/top1000_r&d.asp?offset=400 07/ [07/03/2008]
- Wigginton, M and McCarthy, B. 2000. Double Skin Façade: Environmental Characteristics and control. Available: <http://www.battlemccarthy.com/Double%20Skin%20Website/environmentalchar/doubles...> [10/09/2008]
- Watch .D, Trends in Lab Design, Available: <http://www.wbdg.org/resources/labtrends.php> [5/03/2008.]

Ground Floor Plan - NTS

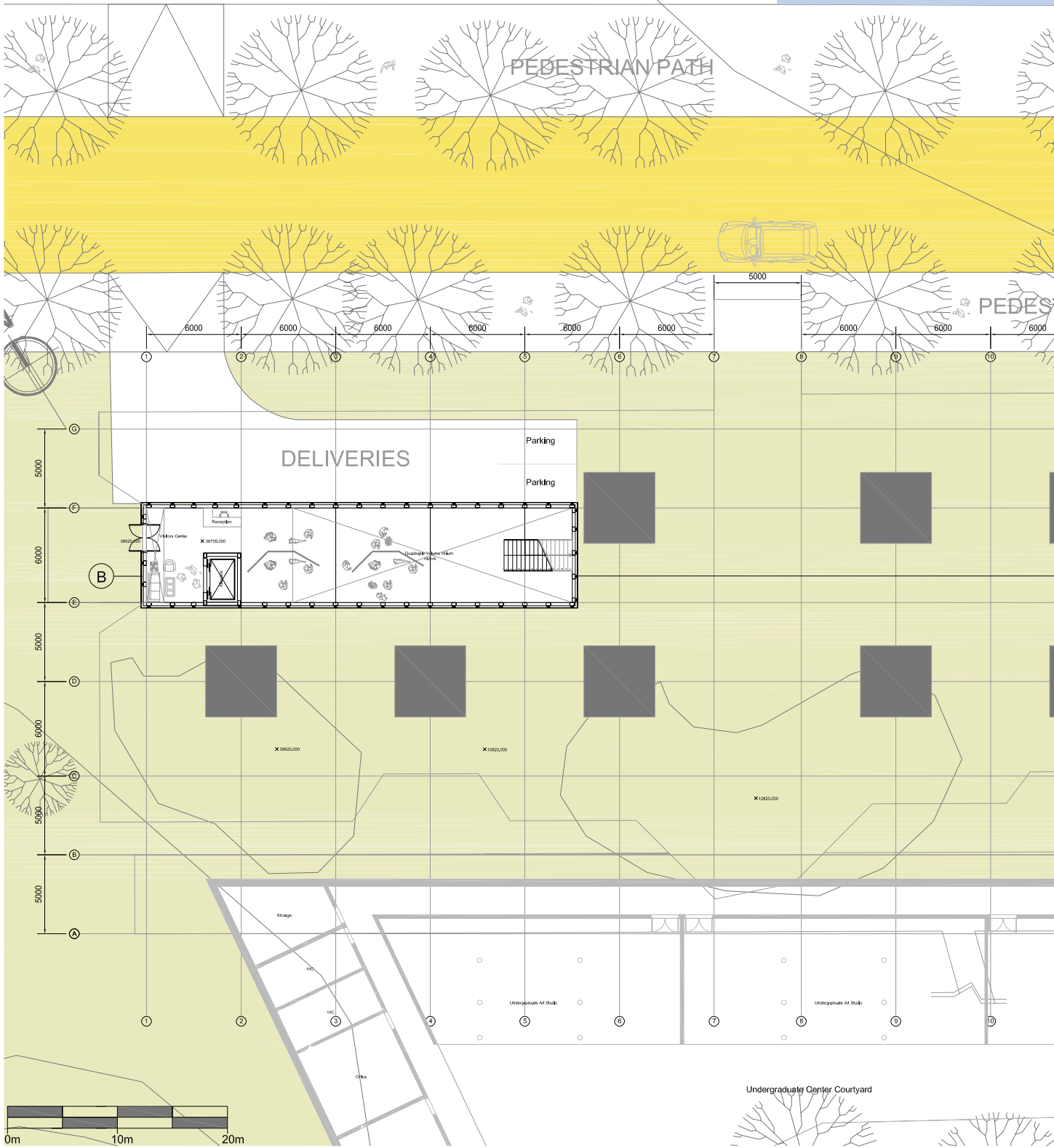

First Floor Plan - NTS

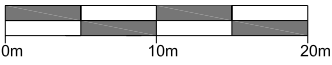
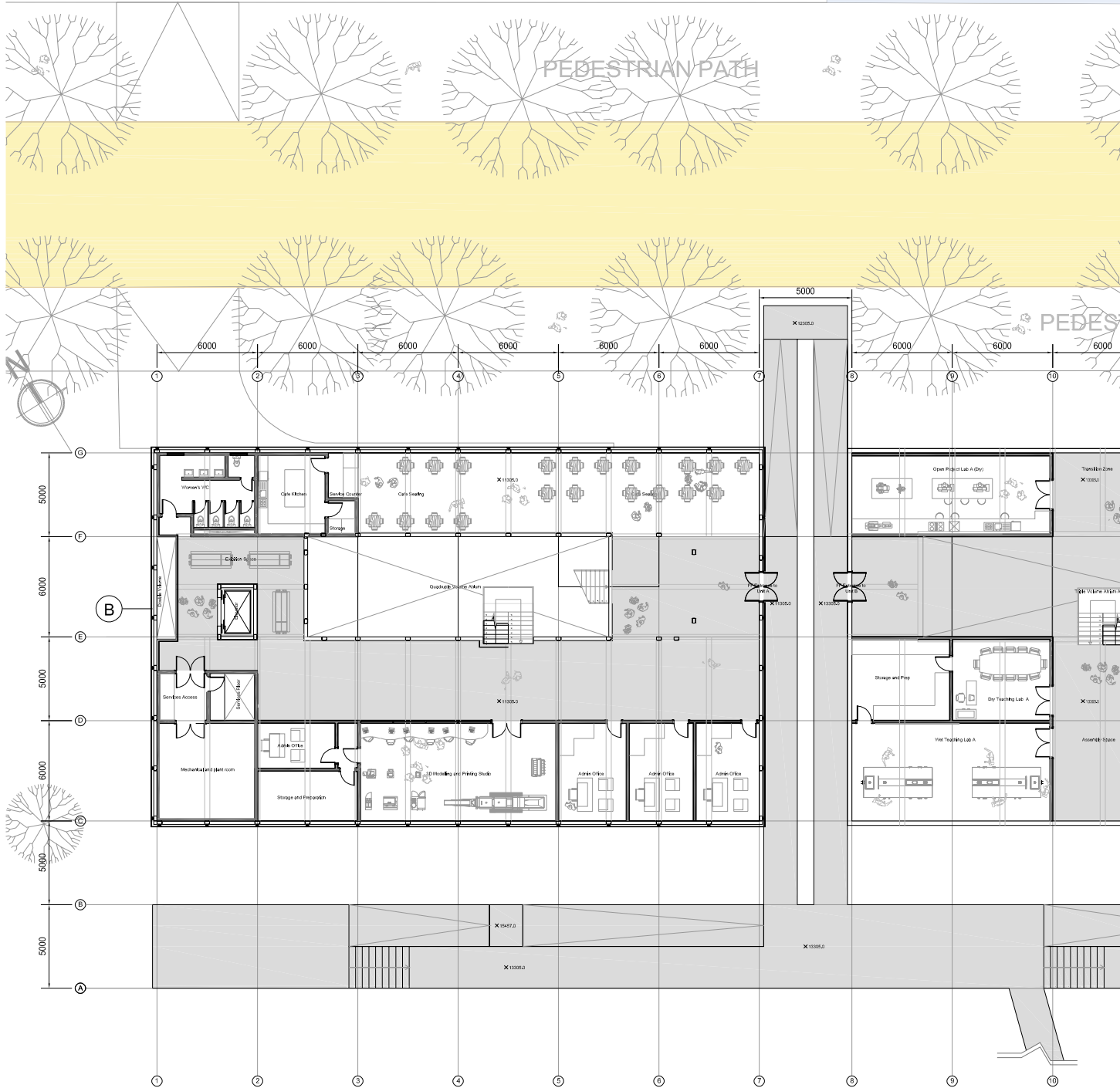

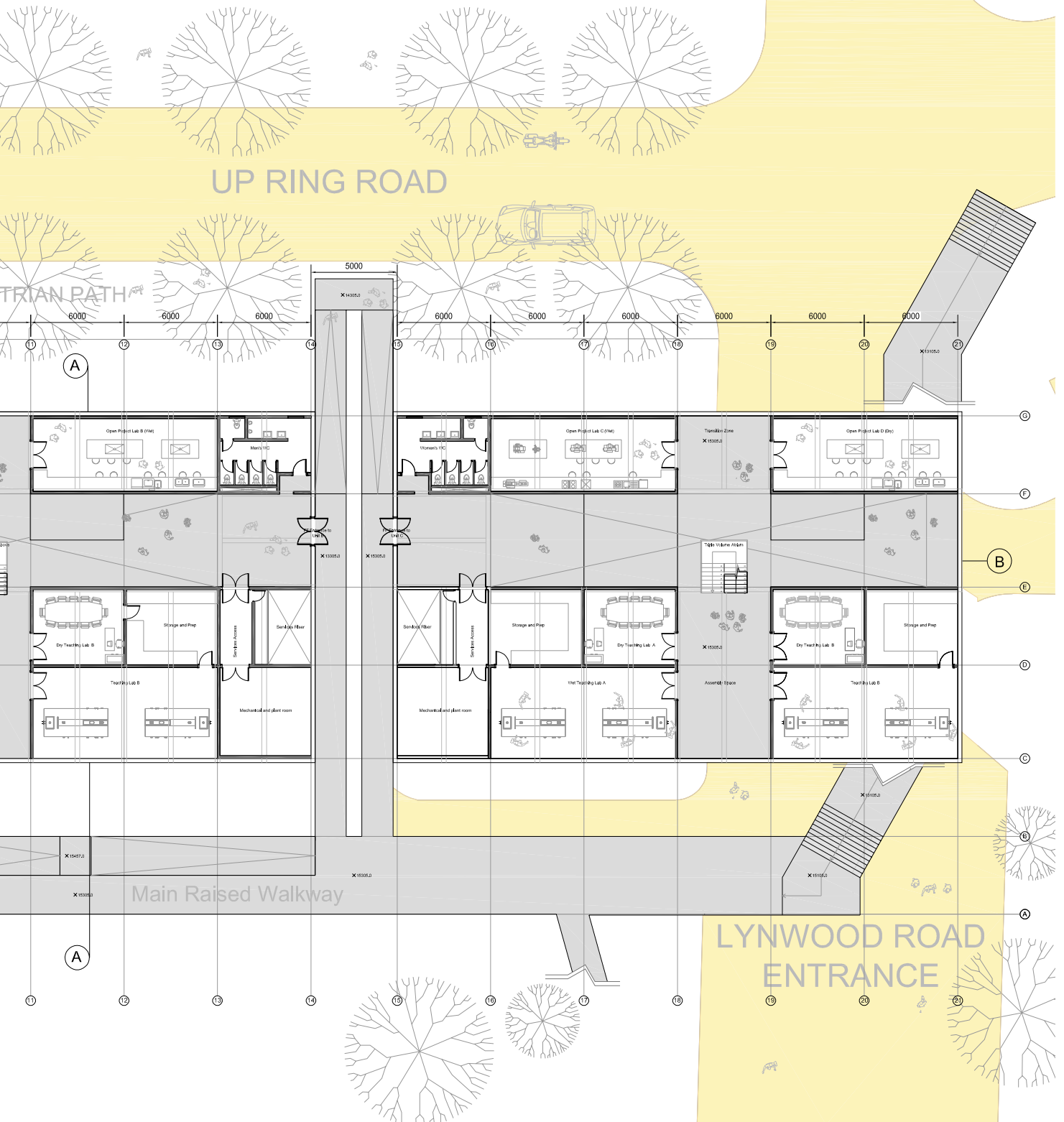

Second Floor Plan - NTS

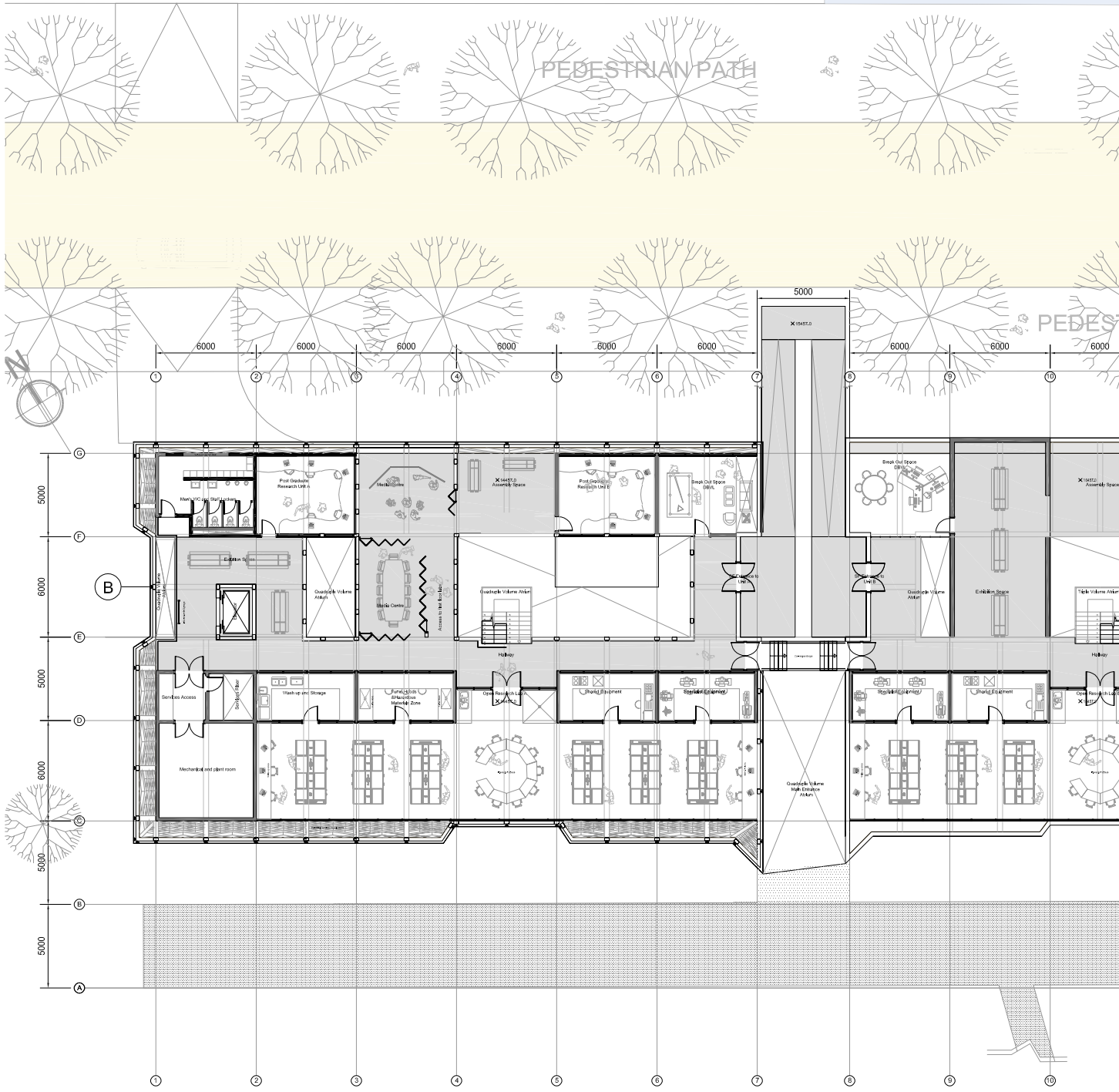

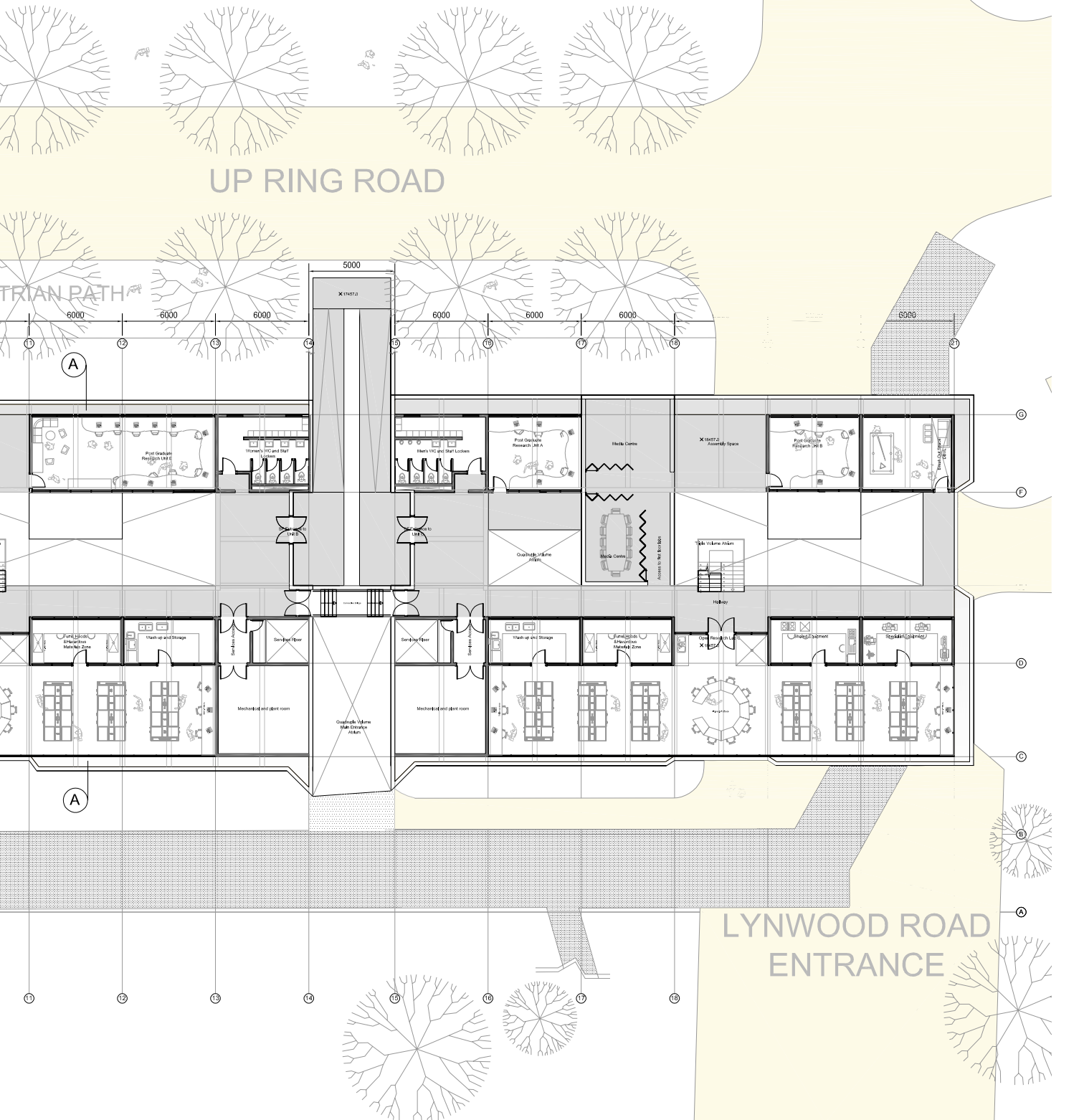

TRIAN PATH

UP RING ROAD

LYNWOOD ROAD
ENTRANCE

Third Floor Plan - NTS

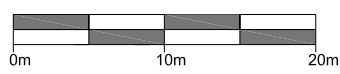
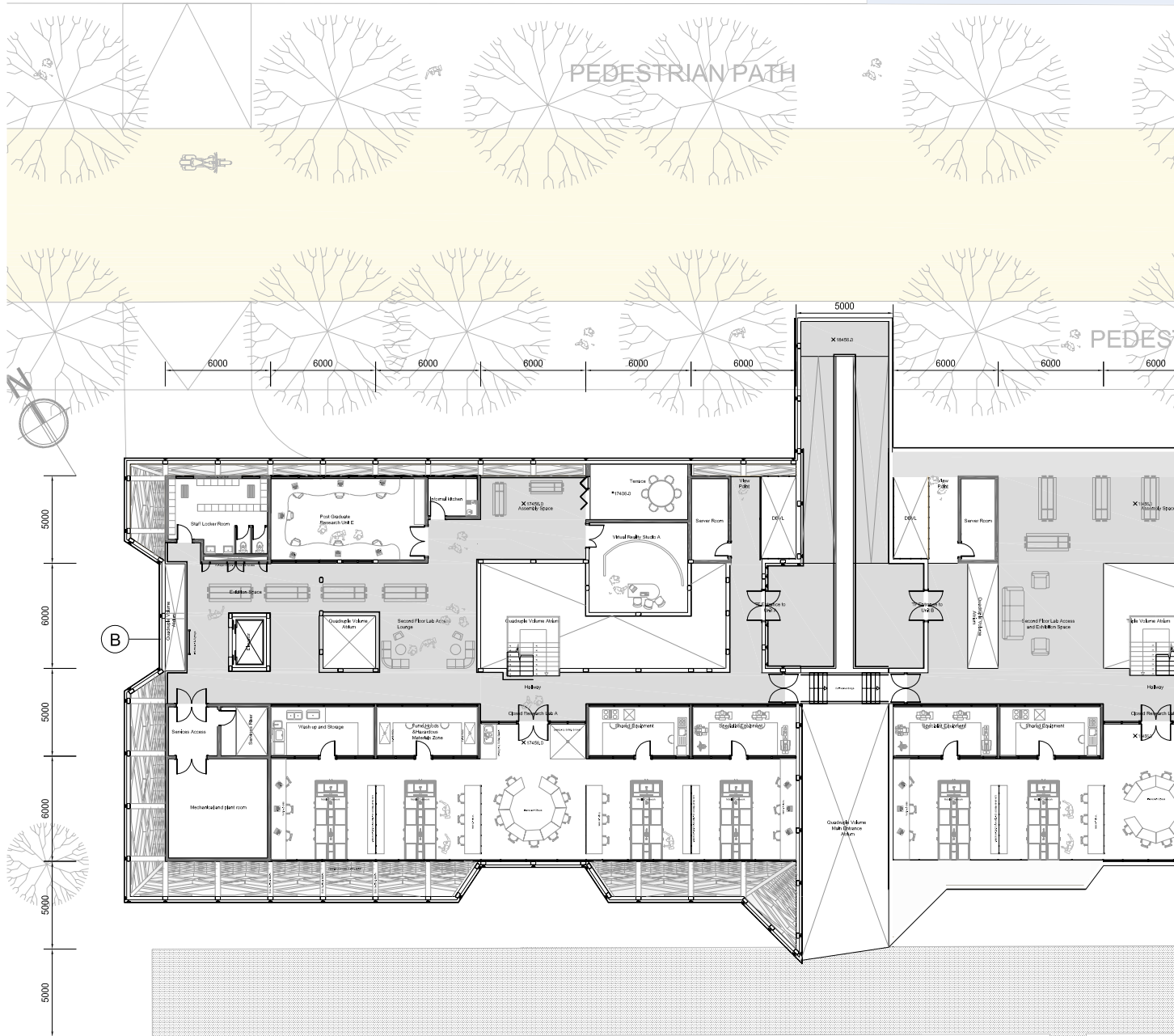

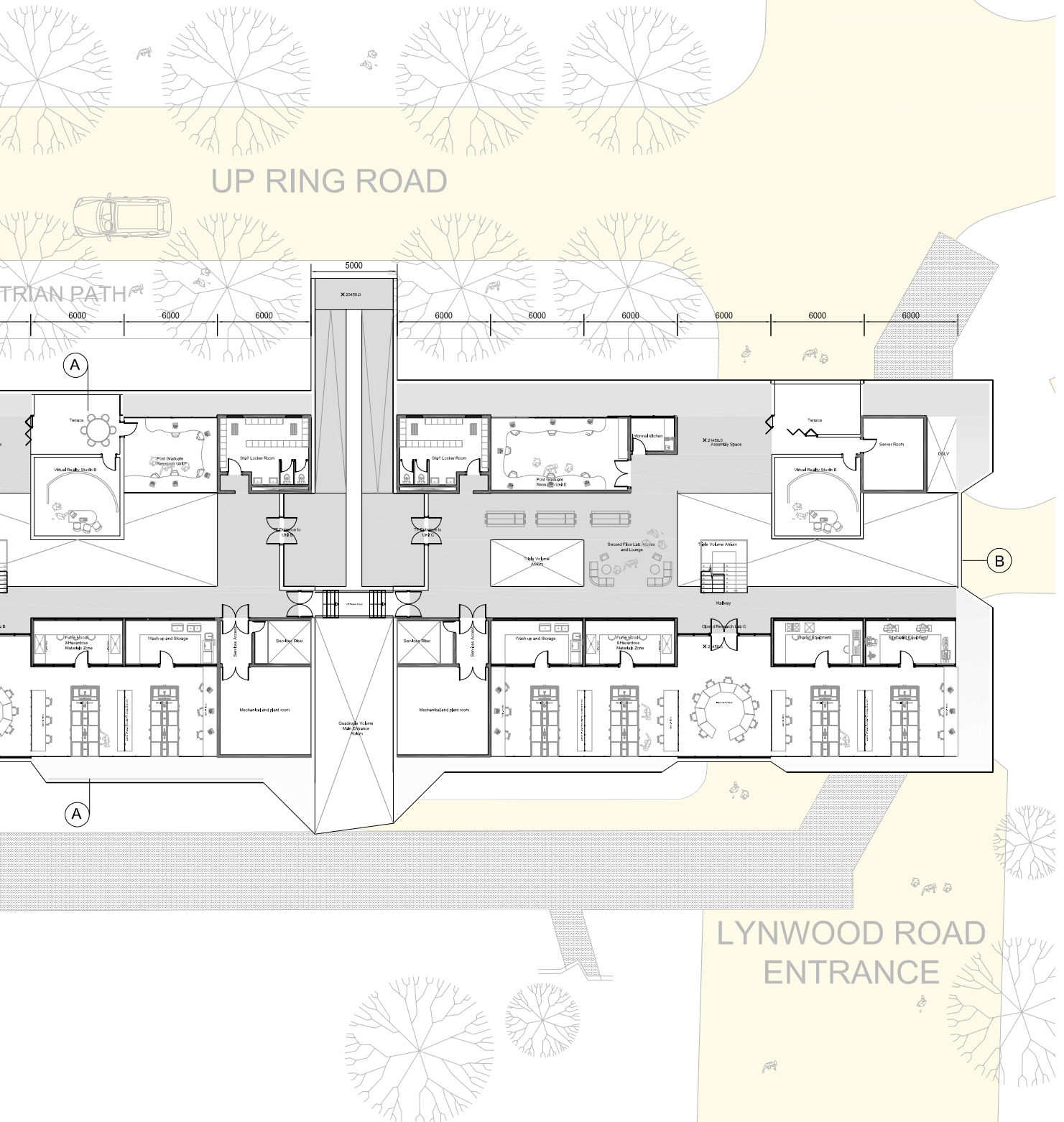

Research Unit A - Ground Floor Plan - 1:250

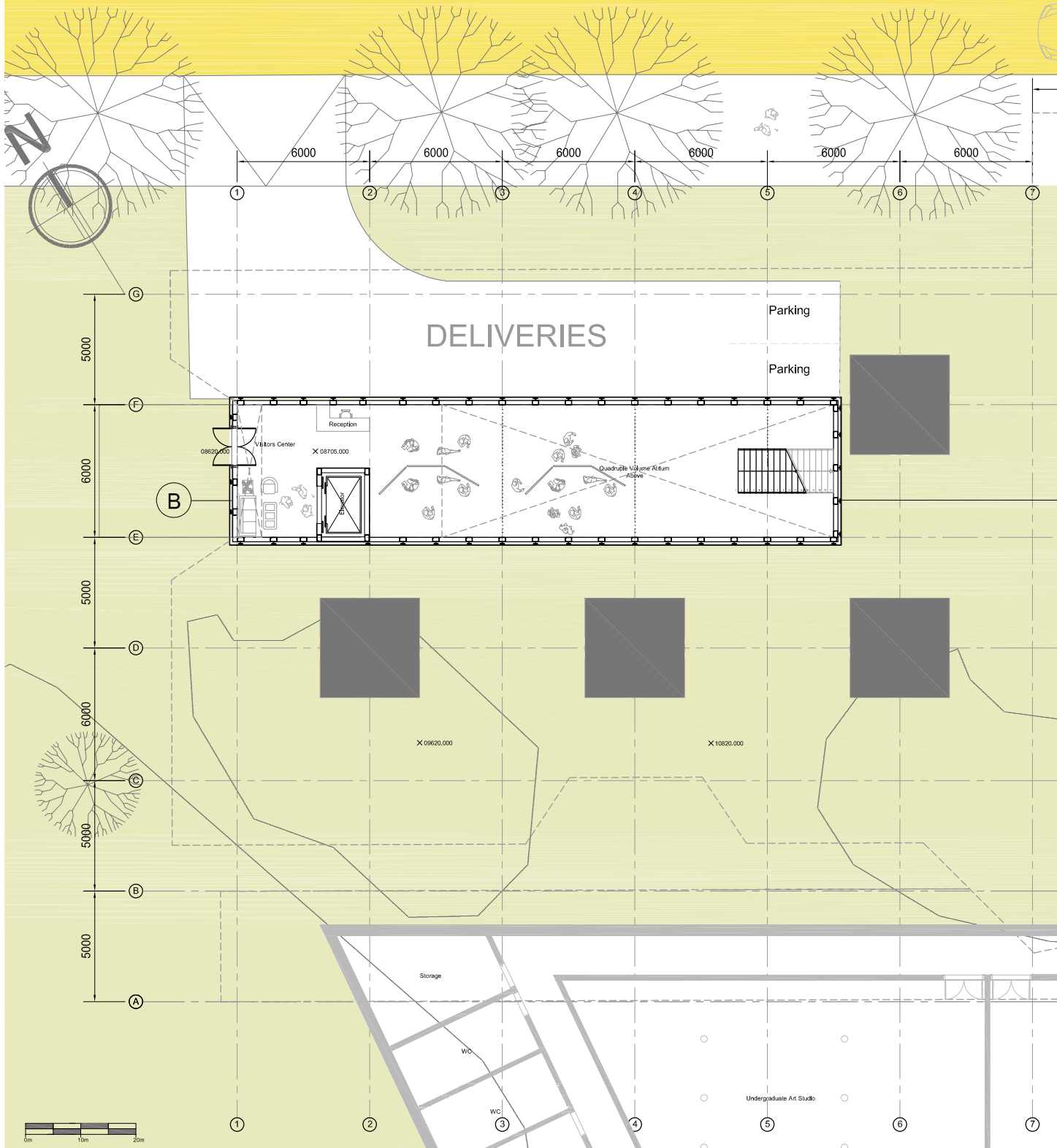

Research Unit A - First Floor Plan - 1:250

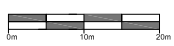
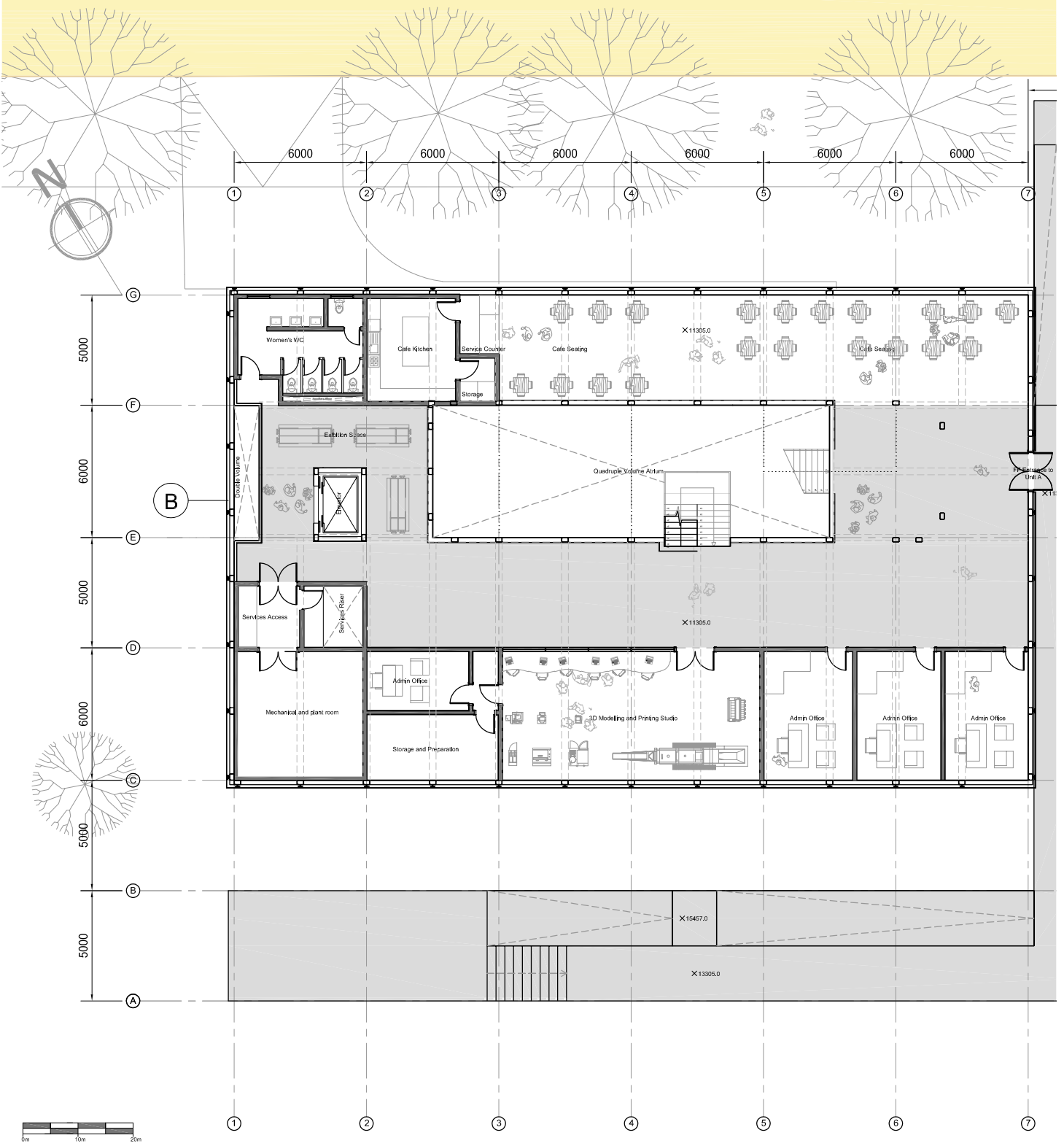

Research Unit A - Second Floor Plan - 1:250

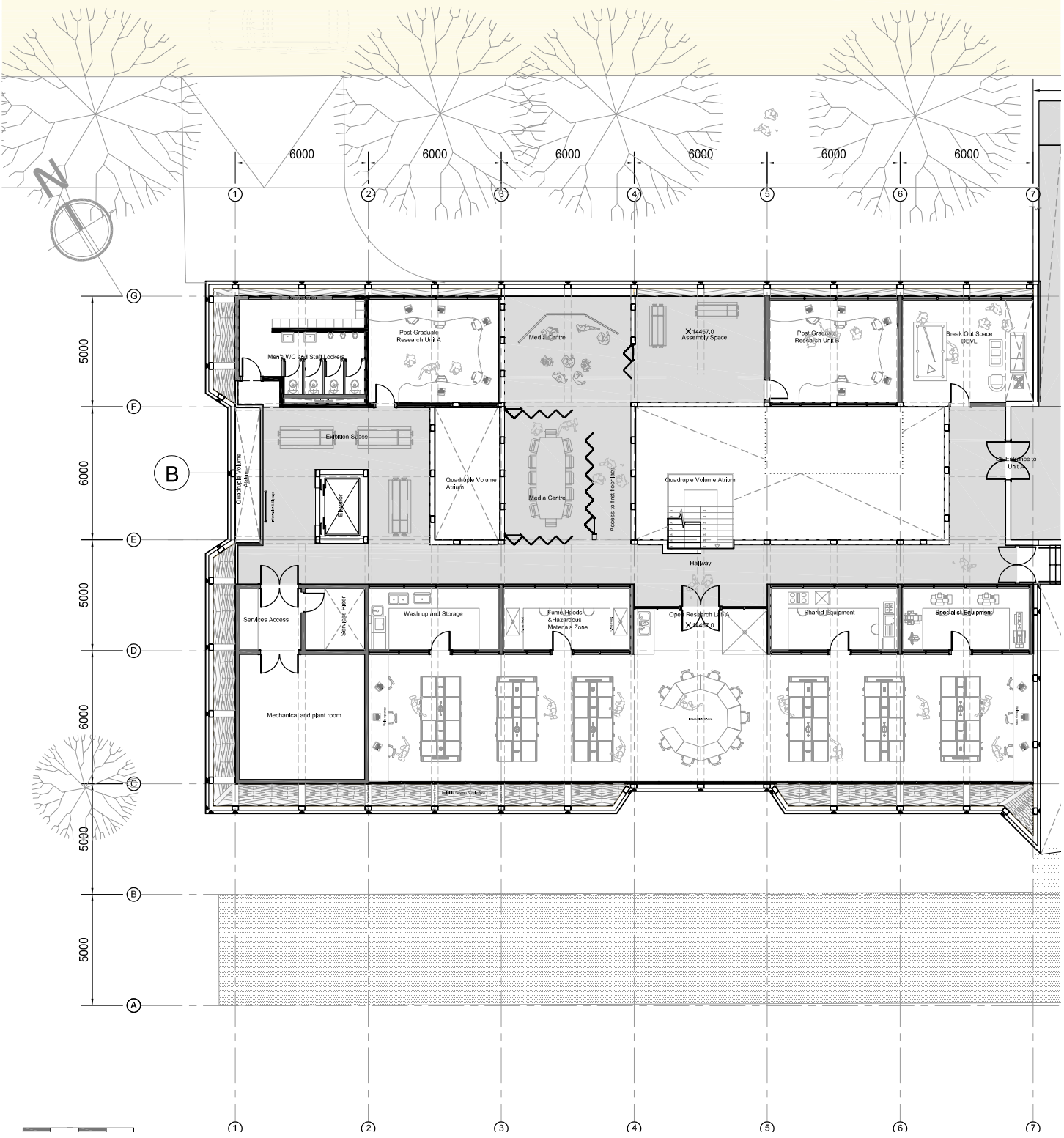

Research Unit A - Third Floor Plan - 1:250

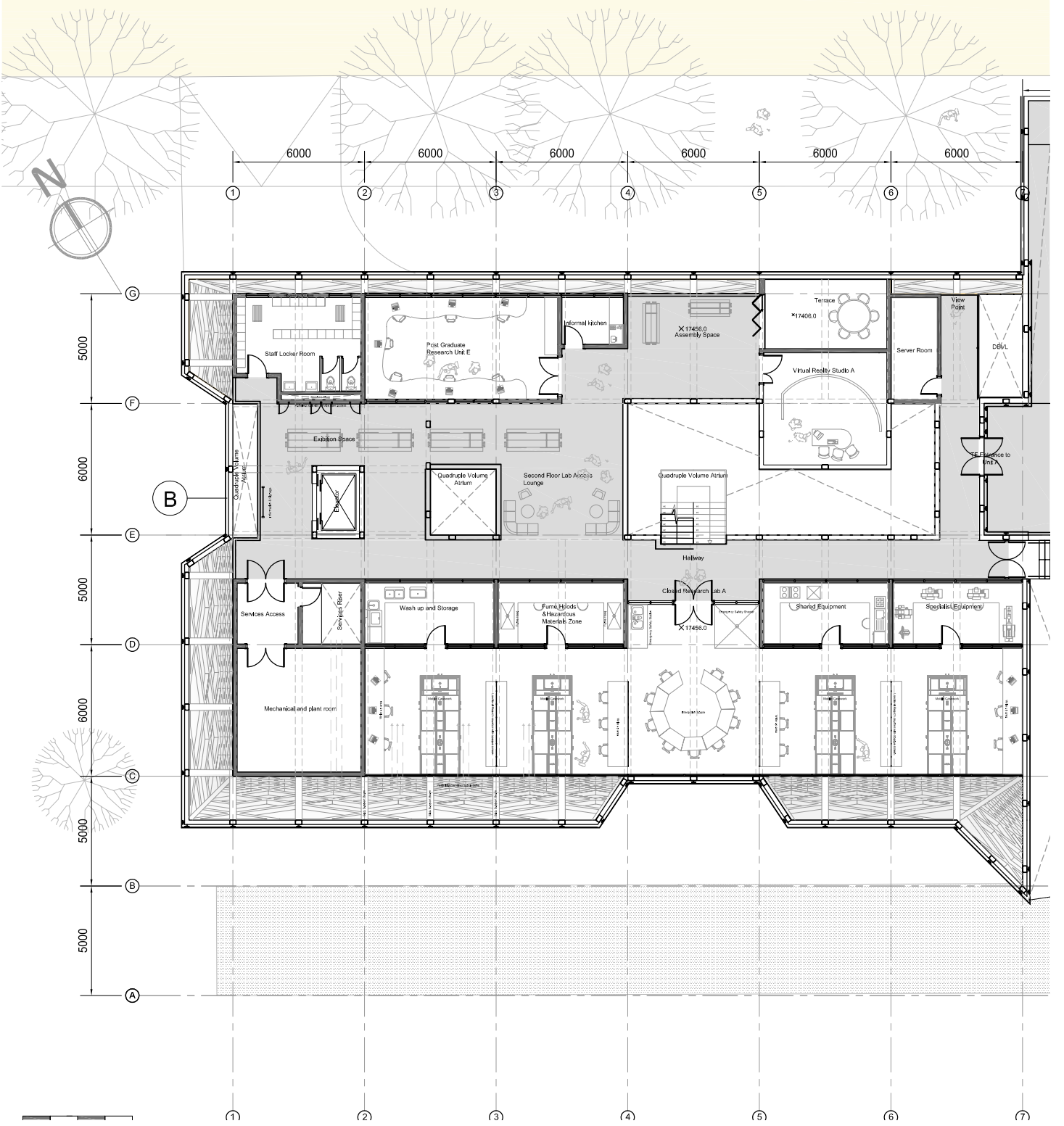

Section AA - Laboratory Section - NTS

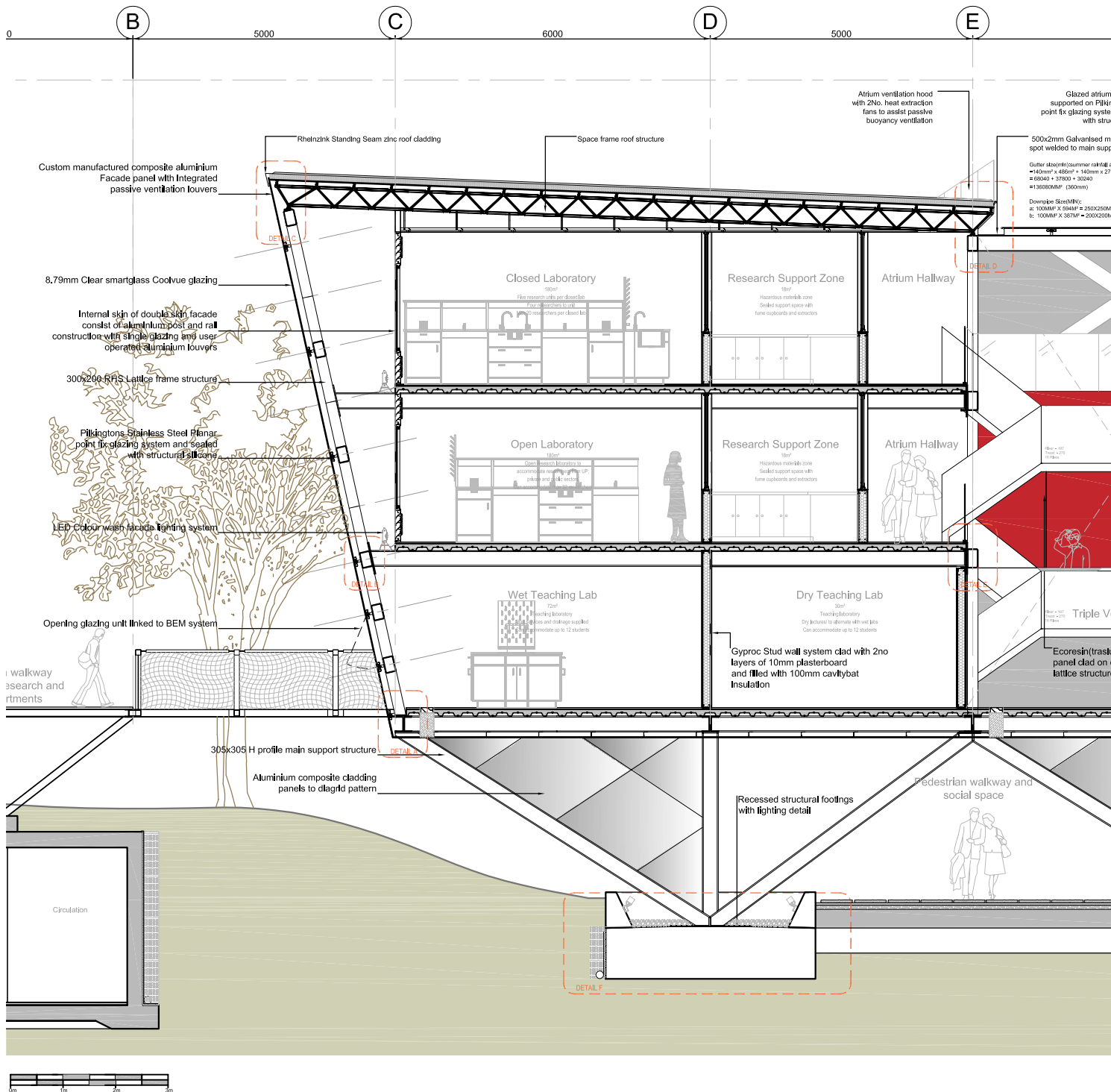

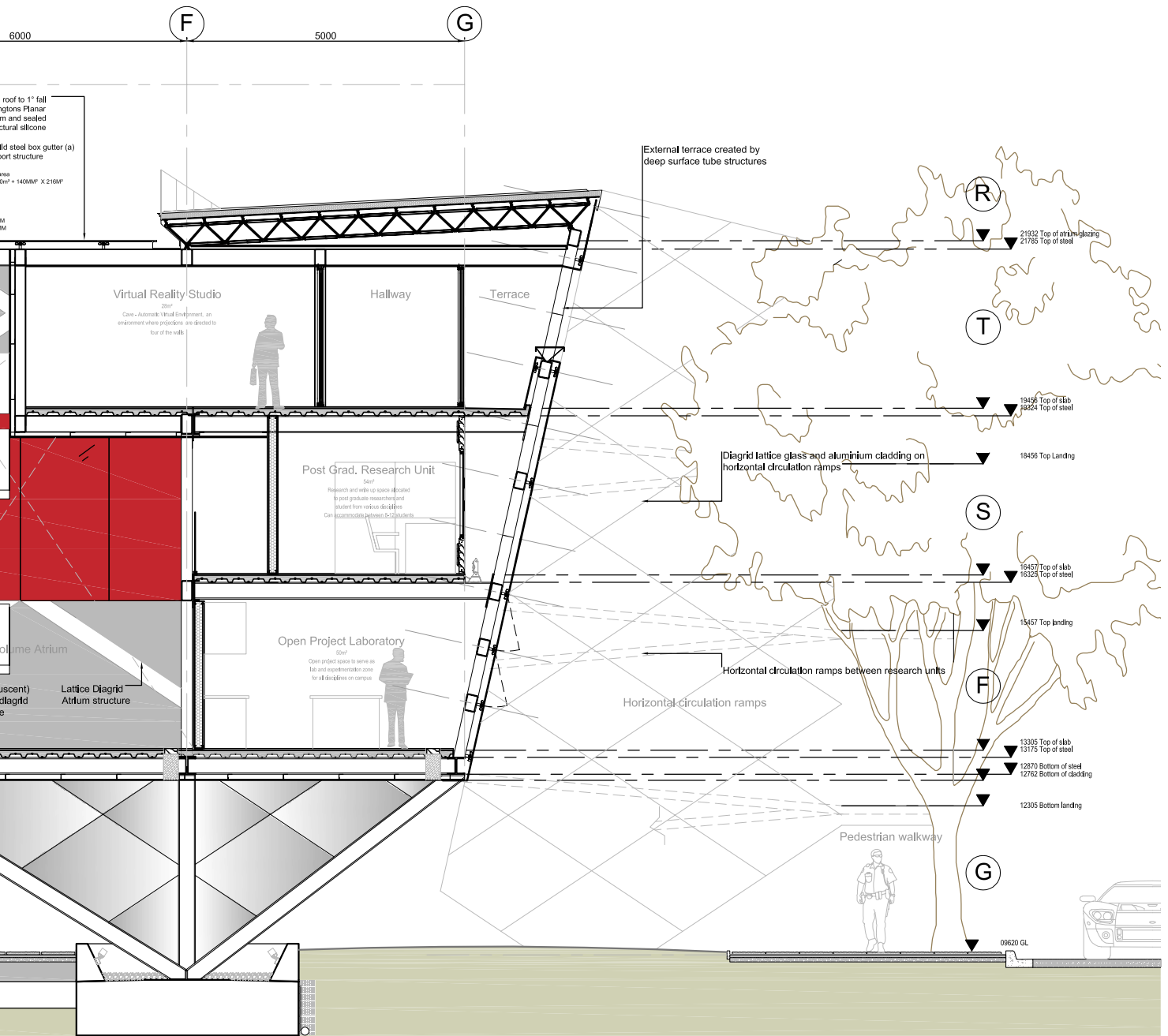

Section BB - Laboratory Section - 1:200

