



UNIVERSITEIT VAN PRETORIA
UNIVERSITY OF PRETORIA
YUNIBESITHI YA PRETORIA

INHERIT VALUE

POPOP SKILLS TRAINING CENTRE SALVOKOP



UNIVERSITEIT VAN PRETORIA
UNIVERSITY OF PRETORIA
YUNIBESITHI YA PRETORIA

Submitted in partial fulfilment of the requirements for the degree of
Master of Interior Architecture (Professional)
in the Faculty of Engineering, Built Environment and Information Technology
University of Pretoria
PRETORIA 2011

BY ZAKKIYA KHAN

STUDY LEADER: CATHERINE KARUSSEIT
COURSE CO-ORDINATOR: JACQUES LAUBSCHER

Project Summary

Full dissertation title: Inherit Value, POPUP Skills Training Centre, Salvokop

Submitted by: Zakkiya Khan (Ms)
Student number: 29159475

Study leader: Catherine Karusseit (Ms)
Course coordinator: Jacques Laubscher (Dr)

Degree: Master of Interior Architecture (Professional)

Department: Department of Architecture
Faculty: Faculty of Engineering, Built Environment and Information Technology
University: University of Pretoria

Programme: Skills Training Centre
Site description: Historical Building within Salvokop across the railway line from Pretoria Station
Client: People's Upliftment Programme (POPUP)
Users: Learners of Skills Training Centre, Staff and Teachers of Skills Training Centre, Visitors from Public

Site Location: Salvokop, Pretoria
Address: Off Skietpoort Avenue, Salvokop, Pretoria, South Africa

Design Theoretical Premise: The relationship between historical architecture, alteration and current cultural production
Design Approach: Intervention on an existing historical building for a changed time, user and programme
Research filed: Heritage and Cultural Landscapes

Declaration

In accordance with Regulation 4(e) of the General Regulations (G.57) for dissertations and theses, I declare that this dissertation, which I hereby submit for the degree Master of Interior Architecture (Professional) at the University of Pretoria, is my own work and has not previously been submitted by me for a degree at this or any other tertiary institution.

I further state that no part of my dissertation has already been, or is currently being, submitted for any such degree, diploma or other qualification.

I further declare that this thesis is substantially my own work. Where reference is made to the works of others, the extent to which that work has been used is indicated and fully acknowledged in the text and list of references.

The dissertation is 17862 words long (Chapter 1 - Chapter 8, excluding the scanned items).

Zakkiya Khan



ABSTRACT

This dissertation responds to the problem that intervention on historical architecture generally represents a loss of value to the existing building and new programme. It investigates the relationship between the alteration of historical architecture and the introduction of new intervention which reflects current users, time and programme through cultural production.

Historical architecture is static and rejects the notion of change. Interior design opts to alter the existing to ensure new inhabitation in changing times. Cultural production is the process by which products are designed to relate intrinsically to their user group culture and identity.

The study links all three factors through the design of the People's Upliftment Programme skills training centre in Salvokop (2011 POPUP), in a building which was constructed in 1909 as the chief engineer's office (1909 CEO) for Pretoria's railway line.

The project seeks to identify a balance between retaining the identity and character of the existing ("historical ideal"), and explicitly reflecting the energy of the skills learners and skills training programmes which have subsequently occupied the building.

<i>Title Page</i>	<i>i</i>
<i>Project Summary</i>	<i>ii</i>
<i>Declaration</i>	<i>ii</i>
<i>Abstract</i>	<i>iii</i>

TABLE OF CONTENTS

<i>List of Tables</i>	<i>vi</i>
<i>List of Figures</i>	<i>vi</i>
<i>List of Illustrations</i>	<i>vi - ix</i>

1 INTRODUCTION		1
1.1 Introduction	2	
1.2 Background	3	
1.3 Research Problem	4 - 5	
1.4 Design	6 - 8	
1.5 Methods	9 - 11	
1.6 Conclusion	11	
2 CONTEXT AND SITE		13
2.1 Introduction	14	
2.2 Greater Context	15 - 17	
2.3 Historical Context	18 - 21	
2.4 Urban Framework	22	
2.5 Site Analysis	23 - 27	
2.5.1 Urban to Interior		
2.5.2 Sense of Place		
2.5.3 Internal Spatial Quality		
2.5.4 Space and Use		
2.5.5 Alterations and Additions		
2.6 Establishing Ideal	28 -30	
2.7 Conclusion	31	
3 THEORY		33
3.1 Introduction	34	
3.2 Legislation and Guidelines	35	
3.2.1 National Heritage Resources Act (NHRA)		
3.2.2 The Burra Charter		
3.3 Cultural Production in Historical Architecture	36	
3.4 Alteration	37	
3.5 Stripping Back	38	
3.6 Conclusion	39	
4 PRECEDENT & CASE STUDIES		41
4.1 Introduction	42	
4.2 Heritage	43 - 48	
4.2.1 Rehabilitation of Santa Caterina Market, Barcelona		
4.2.2 Ogilvy Offices, Durban		
4.2.3 Cape Quarter, Cape Town		
4.2.4 Tate Modern, London		
4.2.5 Jolie Toujours, Tokyo		



4.3 Cultural Production	49
4.3.1 Imagine life on the other side of the planet, Perth	
4.3.2 Kasa Digitalia, Milan	
4.4 Community	50
4.4.1 Barking Skills Centre, Edinburgh	
4.5 Conclusion	51
5 DESIGN DEVELOPMENT	53
5.1 Introduction	54
5.2 Steam punk	55
5.3 Concept (April 2011)	56 - 63
5.3.1 Design Draft 1	
5.3.2 Design Draft 2	
5.4 Concept Development (May 2011)	64 - 67
5.5 Design Development (June 2011)	68 - 75
5.5.2 Entrance	
5.5.2 Cultural Production	
5.5.3 Light	
5.5.4 General Comments	
5.6 Accommodation Requirements (July 2011)	76 - 77
5.6.1 Dining Hall	
5.6.2 Studios	
5.6.3 Food LAB	
5.6.4 Lecture Rooms	
5.7 Branding (July 2011)	78 - 79
5.8 Final Design (July - October 2011)	80 - 94
5.8.1 Design Outline	
5.9 Conclusion	95
6 TECHNICAL DEVELOPMENT	94
6.1 Introduction	98
6.2 Approach	99
6.3 Services	100 - 109
6.4 Materials	110 - 111
6.5 Inclusive Design	112
6.6 Sustainability	113
6.7 Details	114 - 127
6.8 Conclusion	128
7 CONCLUSION	129
7.1 Conclusion	130
8 BIBLIOGRAPHY	131
<i>APPENDIX A - Urban Framework</i>	135
<i>APPENDIX B - Design Perspectives</i>	144
<i>APPENDIX C - Examination Presentation</i>	146

LIST OF TABLES

Table 1.1 Grounded theory research phases (Groat & Wang, 2008:181)	9
Table 2.1 Time Line, Salvokop (Bakker, 2002) formatted by (Author, 2011)	20 - 21

LIST OF FIGURES

Fig 1.1 Design Methods (Author, 2011)	10 - 11
--	---------

LIST OF ILLUSTRATIONS

Illus 0 Cover Image (Bakker, 2002) edited by (Author, 2011)	i
Illus 1 1909 Chief Engineer’s Office and users (Peoria, s.a.) edited by (Author, 2011)	1
Illus 1.1 Actors in Cultural Production (Author, 2011)	4
Illus 1.2 Aerial Photograph of Salvokop (Google Earth, 2011)	6
Illus 1.3 Chief Engineer’s Office, 1909 (Bakker, 2002)	6
Illus 1.4 POPUP (Astrup, 2005:21)	7
Illus 1.5 POPUP’s Sewing Laboratory (Author, 2010)	8
Illus 1.6 Stripping Back: Parti Diagram (Author, 2011)	9
Illus 2 2011 POPUP (Author, 2011) and 1909 CEO (Bakker, 2002) edited by (Author, 2011)	13
Illus 2.1 Locality Maps (Author, 2011)	15
Illus 2.2 Aerial photo, Salvokop (Google Earth, 2011) edited by (Author, 2011)	16
Illus 2.3 Residential Character (Author, 2011)	17
Illus 2.4 Breathing Space (Google Earth, 2011) edited by (Author, 2011)	17
Illus 2.5 Ecological Systems (Google Earth, 2011) edited by (Author, 2011)	17
Illus 2.6 Historical Character (Author, 2011)	17
Illus 2.7 Time Mapping, Salvokop (Author, 2011)	18 - 19
Illus 2.8 Salvokop Framework (Google Earth, 2011) edited by (Author, 2011)	22
Illus 2.9 Strengths Weaknesses Opportunities Threats Mapping (Author, 2011)	23
Illus 2.10 Urban to Interior (Author, 2011)	24
Illus 2.11 Sense of Place (Author, 2011)	24
Illus 2.12 Aerial photo of POPUP’s site and programming (Google Earth, 2011) edited by (Author, 2011)	25
Illus 2.13 Internal Spatial Quality (Author, 2011)	26
Illus 2.14 Space and Use (Author, 2011)	26 - 27
Illus 2.15 Alterations and Additions (Author, 2011)	27
Illus 2.16 Establishing Ideal (Author, 2011)	28
Illus 2.17 Establishing Ideal (Author, 2011)	29
Illus 2.18 Site Character (Author, 2011)	30
Illus 3. Cultural Products (Author, 2011)	33
Illus 3.1 Change in Occupation (Bakker, 2002) & (Author, 2011)	37
Illus 3.2 Alteration Processes (Author, 2011)	37
Illus 4 Untitled (Cohn, 2006: [100]) (Schauffer, 2011: 24) (Author, 2011) (Takahashi, 2008: 5) (De Wild, 2008: 178) (Smith, 2004) (De Wild2, 2008: 65) (Phaidon, 2010)	41
Illus 4.1 Santa Caterina Market’s colourful roof (Cohn, 2006: [100])	43
Illus 4.2 Santa Caterina Market street view (Cohn, 2006: [101])	44

Illus 4.3 Santa Caterina Market interior (Cohn, 2006: [100])	44
Illus 4.4 Entrance (Schauffer, 2011: 25)	45
Illus 4.5 Harbour Elements (Schauffer, 2011: 24)	45
Illus 4.6 Boardroom Materials (Schauffer, 2011: 26)	45
Illus 4.7 Historical Images of the block and users (Cape Quarter, 2009)	46
Illus 4.8 Cape Quarter facade (Author, 2011)	46
Illus 4.9 Interior Exterior Space (Cape Quarter, 2009)	46
Illus 4.10 Tate Modern (Perrin, 2002)	47
Illus 4.11 Tate Modern Volume, Skylight and Atrium (Smith, 2004)	47
Illus 4.12 Jolie Toujours (Takahashi, 2008: 5)	48
Illus 4.13 Imagine life on the other side of the planet (Kimme, 2008: 53)	49
Illus 4.14 Kasa Digitalia (De Wild2, 2008: 65)	49
Illus 4.15 Barking Skills Centre and square (Rick Mather Architects, 2009)	50
Illus 4.16 Barking Skills Centre and context (Rick Mather Architects, 2009)	50
Illus 4.17 Barking Skills Centre and the Barking Methodist Church (Rick Mather Architects, 2009)	50
Illus 5 Untitled (Author, 2011)	53
Illus 5.1 Steam punk (Author, 2011)	55
Illus 5.2 Jules Verne's "20 000 Leagues under the sea" (1869) is a classic literary work which influenced the steam punk movement (Willis, 2009)	55
Illus 5.3 Hayao Miyazaki's "Laputa Castle in the Sky" (1986) is a Japanese anime film which falls within steam punk genre (Canth, 2011)	55
Illus 5.4 Jean Pierre Jeunet's "The city of the lost children" (1995) is stylised and contains steam punk elements (Hudler, 2010)	55
Illus 5.5 Mood board 1, April 2011 (Author, 2011)	57
Illus 5.6 Mood board 2, May 2011 (Author, 2011)	57
Illus 5.7 Model 1, May 2011 (Author, 2011)	58
Illus 5.8 Model 2, May 2011 (Author, 2011)	59
Illus 5.9 Plans and Section, May 2011 (Author, 2011)	60 - 61
Illus 5.10 3 Dimensional Stripping Back Study, May 2011 (Author, 2011)	62
Illus 5.11 Re-imagining the Historical "Ideal", May 2011 (Author, 2011)	62 - 63
Illus 5.12 Mood Plan (Author, 2011)	65
Illus 5.13 Diagrammatic Plan (Author, 2011)	66
Illus 5.14 "Historical Ideal" Plan (Author, 2011)	67
Illus 5.15 Site Plan (Author, 2011)	68
Illus 5.16 Aerial view of site (Author, 2011)	68
Illus 5.17 Plan through Entrance 1:200 (Author, 2011)	69
Illus 5.18 Section A through Entrance 1:200 (Author, 2011)	69
Illus 5.19 Sketch of entrance and arrival (Author, 2011)	70
Illus 5.20 Sketch of entrance and arrival (Author, 2011)	70
Illus 5.21 Ground and Mezzanine 1 Floor Plans 1:200 (Author, 2011)	72
Illus 5.22 First and Mezzanine 2 Floor Plans 1:200 (Author, 2011)	73
Illus 5.23 Second Floor Plan 1:200 (Author, 2011)	74
Illus 5.24 Process Sketches (Author, 2011)	74
Illus 5.25 Section B 1:200 (Author, 2011)	75
Illus 5.26 Section C 1:200 (Author, 2011)	75
Illus 5.27 Ergonomic seating conditions (Neufert, 1999: 16)	77



Illus 5.28 Dining Seating Conditions (Neufert, 1999: 455)	77
Illus 5.29 POPUP logo (POPUP, S.A.)	78
Illus 5.30 MoMA branding (Iheartgum, 2009)	78
Illus 5.31 New POPUP logo (Author, 2011)	78
Illus 5.32 POPUP logo Variations (Author, 2011)	79
Illus 5.33 Ground Floor Plan - 1:200 (Author, 2011)	81
Illus 5.34 Mezzanine 1 Floor Plan - 1:200 (Author, 2011)	82
Illus 5.35 First Floor Plan - 1:200 (Author, 2011)	83
Illus 5.36 Mezzanine 2 Floor Plan - 1:200 (Author, 2011)	84
Illus 5.37 Second Floor Plan - 1:200 (Author, 2011)	85
Illus 5.38 Section A - 1:200 (Author, 2011)	86
Illus 5.39 Section B - 1:100 (Author, 2011)	87
Illus 5.40 Section C (Author, 2011)	88 - 89
Illus 5.41 View of POPUP building from Salvokop Bridge (Author, 2011)	90
Illus 5.42 Entrance to POPUP (Author, 2011)	91
Illus 5.43 View of POPUP building from Railway Line (Author, 2011)	92
Illus 5.44 Railway Promenade (Author, 2011)	93
Illus 6 Untitled (Author, 2011)	100
Illus 6.1 Overlay of Plans indicating Services (Red - Fire, Blue - Wet) (Author, 2011)	101
Illus 6.2 Site Plan indicating delivery entrance along west 1:500 (Author, 2011)	102 - 103
Illus 6.3 Fittings (Radiant, 2011)	104
Illus 6.4 Materials(Author, 2011)	104
Illus 6.5 Ceiling Plans Above Ground 1:200 (Author, 2011)	104
Illus 6.6 Ceiling Plans Above M1, Above First 1:200 (Author, 2011)	105
Illus 6.7 Ceiling Plans Above M2, Above Second 1:200 (Author, 2011)	106
Illus 6.8 Materials and Key (Author, 2011)	107
Illus 6.9 Floor Finishes - Ground (Author, 2011)	107
Illus 6.10 Floor Finishes - M1 & First (Author, 2011)	108
Illus 6.11 Floor Finishes - M2 & Second (Author, 2011)	109
Illus 6.12 Materials Palette (Author, 2011)	110
Illus 6.13 <i>Evac+Chair</i> (Evac+Chair, 2004)	112
Illus 6.14 Concept and Materials (Author, 2011)	114
Illus 6.15 Stages 1 - 4 (Author, 2011)	114
Illus 6.16 Stages 5 - 8 (Author, 2011)	115
Illus 6.17 Section and Plan 1:25 (Author, 2011)	115
Illus 6.18 Concept and Materials (Author, 2011)	116
Illus 6.19 Inspiring Artworks (POPUP Students, 2011)	116
Illus 6.20 Wallpaper Graphic (Author, 2011)	116
Illus 6.21 Elevation Perspective (Author, 2011)	117
Illus 6.22 Sectional Perspective (Author, 2011)	117
Illus 6.23 Concept and Materials (Author, 2011)	118
Illus 6.24 Pieces for Assembly (Author, 2011)	118
Illus 6.25 Section and Elevation of Food LAB and Media Centre Boxes 1:20 (Author, 2011)	118
Illus 6.26 Section of Studio Storage Box 1:10 (Author, 2011)	119
Illus 6.27 Elevation of Studio Storage Box 1:10 (Author, 2011)	119
Illus 6.28 Concept and Materials (Author, 2011)	120

Illus 6.29 Infill, Thread and Frame pieces for crafter's use (Author, 2011)	120
Illus 6.30 Shape Abstraction (Author, 2011)	120
Illus 6.31 Infill Options (Author, 2011)	121
Illus 6.32 3D Explosion for Assembly (Author, 2011)	121
Illus 6.33 Concept and Materials (Author, 2011)	122
Illus 6.34 Isometric of Leg and Beam (Author, 2011)	122
Illus 6.35 Plan of Seat (Author, 2011)	122
Illus 6.36 Shape Abstraction (Author, 2011)	122
Illus 6.37 Seating Configurations (Author, 2011)	123
Illus 6.38 Partially Exploded 3D of Single Seating Unit (Author, 2011)	123
Illus 6.39 Two Seating Units in "Bench" configuration (Author, 2011)	123
Illus 6.40 Concept and Materials (Author, 2011)	124
Illus 6.41 Perspective of Dining Hall with Tables (Author, 2011)	124
Illus 6.42 3D Detail of Table (Author, 2011)	124
Illus 6.43 Table Surface Finishes in Spaces (Author, 2011)	125
Illus 6.44 Two 700 x 700 mm Tables (Author, 2011)	125
Illus 6.45 One 700 x 1400 mm Table (Author, 2011)	125
Illus 6.46 Mortise and Tenon Joint (Author, 2011)	125
Illus 6.47 Concept and Materials (Author, 2011)	126
Illus 6.48 Inspiration Images (Mode de Mundo, 2010; Dan's Upholstery, S.A. Mary, 2010)	126
Illus 6.49 Frame Component (Author, 2011)	126
Illus 6.50 Textile Roll Screen in Use (Author, 2011)	127
Illus 6.51 Base Component (Author, 2011)	127
Illus 9.1 Analysis of existing GAPP Framework (Salvokop Group, 2011)	136
Illus 9.2 Analysis of existing Tshwane Open Space Framework (TSOP) (Salvokop Group, 2011)	136
Illus 9.3 Analysis of existing Re Kgabisa Framework (Salvokop Group, 2011)	137
Illus 9.4 Framework Map (Salvokop Group, 2011)	138 - 139
Illus 9.5 Tshwane Open Space Framework Guideline Coding over New Framework Map (Salvokop Group, 2011)	140 - 141
Illus 9.6 Phases 1 - 3 & All Phases Overlay (Salvokop Group, 2011)	142 - 143
Illus 9.7 Current Condition (Author, 2011)	144
Illus 9.8 "Historical Ideal" - 1909 CEO (Author, 2011)	144
Illus 9.9 2011 POPUP (Author, 2011)	144
Illus 9.10 Entrance Hall (Author, 2011)	145
Illus 9.11 Food LAB Meeting Area / Banquet Space (Author, 2011)	145
Illus 9.12 Atrium and Mezzanine Spaces (Author, 2011)	145
Illus 9.13 The Author before design examination (Di Monte, 2011)	146
Illus 9.14 Sectional Structural Model (Author, 2011)	146
Illus 9.15 Detail 3.1 Model (Author, 2011)	146
Illus 9.16 The Author presenting the design project to the examination panel (Di Monte, 2011)	147
Illus 9.17 Detail 5 Model (Author, 2011)	147
Illus 9.18 Detail 6 Model (Author, 2011)	147
Illus 9.19 Examination Presentation (Author, 2011)	148
Illus 9.20 Examination Presentation (Author, 2011)	148
Illus 9.21 Design Model, Entrance View (Author, 2011)	149
Illus 9.22 Design Model, South Facade (Author, 2011)	149
Illus 9.23 Design Model, North Facade and Promenade (Author, 2011)	149
Illus 9.24 Design Models with presentation behind (Di Monte, 2011)	149
Illus 9.25 Design Model, Railway Promenade (Author, 2011)	149
Illus 9.26 Design Model (Author, 2011)	149



“...Processes of change to facilitate re-colonization will tend to usurp a building’s initial integrity and create mongrel buildings” (Scott, 2008:11).

1

Introduction



Illus 1 1909 Chief Engineer’s Office and users (Peoria, s.a.) edited by (Author, 2011)



I.1 INTRODUCTION

This chapter will serve to introduce the study discourse for the programme, M Int (Prof) in the year 2011. The background of the study will be outlined and its significance identified. The research problem and its subsequent research questions will be discussed, with reference to their theoretical context and aims.

Thereafter, the design problem will be introduced. An overview of the building site, typology and client will be provided. Finally, intended methods of research and design will be stated and limitations and assumptions will provide a framework through which the study will occur. The chapter will then be concluded.

I.2 BACKGROUND

“It is the alteration in the rituals of occupation that will cause a building to be considered obsolete”.
(Scott, 2008: 5)

Attitudes to the treatment of existing historical architecture differ and approaches to intervention vary. Historical architecture traditionally experiences intervention through the processes of restoration, preservation, reconstruction, adaptation and new work (Australia, 1999: 2-7). Scott argues that while restoration does seek to re-establish the integrity of a building that once was, the negligence to address change is a denial of the needs of the present and prevents inhabitation (Scott, 2008: 48). Similarly, he argues against the process of preservation, which seeks to retain a building's condition as it stands and prevent future decay, a process which Scott rejects by highlighting the futility of preventing a ruin, which has increased value due to decay, from ruining further (Scott, 2008: 58). Alteration, however, acknowledges a building's failure to provide for a current need and proposes a solution: intervention to the built structure (Scott, 2008: 95). Since interior design is concerned with intervention and inhabitation (König, 2010: 12), it is the third method that most suitably addresses change in occupancy.

Interior design, as a discipline of intervention, has the purpose of reacting to existing built form (König, 2010: 50), and is therefore capable of addressing change in occupancy in existing architecture. Because it is concerned with the interpretation of user needs, habits and desires (König, 2010: 12), the explicit representation of user culture and identity is apparent in the design of interior space. It is in this way that interior design is a cultural product, which influences user identity through filters of perception and meaning (Venkatesh & Meamber, 2006: 4).

The study finds relevance to the context of interior design in South Africa, particularly Pretoria, in its exposure as a discipline which can fulfill the role of intervention on historical buildings in the built environment. This will contribute to the value of the discipline, as one which is capable of successfully transforming the existing and inherited in order to suit current user culture.

I.3 RESEARCH PROBLEM

The research study will strive to build on the concept of interior design as a form of cultural production (Königk, 2010: 51) and motivate its capability as a discipline thereby principled to successfully alter existing historical architecture for new occupation. The dominant research problem is that intervention on historical architecture generally represents a loss of value to both inherited form and new typology (Feilden, 1994: 8).

Interior design is a cultural product (Königk, 2010: 51). Cultural production is the “creation, diffusion and consumption of cultural products” (Venkatesh & Meamber, 2006: 1). In their paper, Venkatesh and Meamber (2006: 4) explain the three actors involved in cultural production and their role in contribution to this process. Using the popular product, iPod, the diagram below (Illus 1.1) demonstrates their explanation.

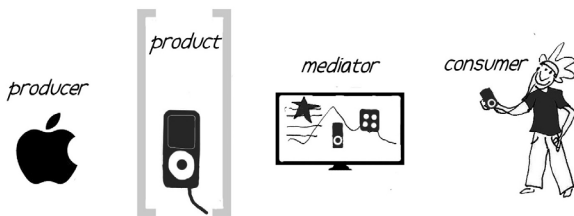

Illus 1.1 Actors in Cultural Production (Author, 2011)

The producer is responsible for the creation of the product, mediators are responsible for communicating the product and consumers absorb and utilize products (Venkatesh & Meamber, 2006: 4). In the context of design, a designer becomes the producer (design is the product), media is the mediator and users are the consumers.

As is evident in the case of an iPod, the consumer extracts meaning from the product and uses it as a part of identity construction (Venkatesh & Meamber, 2006: 4). The iPod transcends its function as a music player and symbolizes trend and youth, which are absorbed by the consumer and expressed in identity. Similarly, design, as a cultural product, has the ability to influence the experience and identity of its users. According to Venkatesh and Meamber, it is the use of symbolism, narratives, and experiences in product creation that opens a product to consumer interpretation (Venkatesh & Meamber, 2006: 9) therefore, the use of symbolism in design is a tool to invoke feeling and meaning in the experience of its users.

Douglas asserts the importance of cultural production by defending the seemingly superficial activity of shopping as that of a reflection of identity and cultural expression (Douglas, 1996: 81). Shopping, as a consumerist act, is linked to the process of cultural production. Although temporal, the act of shopping cannot be dismissed as superficial since it is a meaningful contributor to identity construction and cultural production. All forms of cultural products are temporal and are of relevance for a particular time, they are influenced by cultural priorities of the consumer of a time (Venkatesh & Meamber, 2006: 12). Similarly, interior design, although temporal, imposes a deep impression on the cultural identity of its users and therefore its significance may not be dismissed. Interior design is current, explicit and temporal.

From the perspective of cultural production, the idea of historical architecture for current inhabitation does not fulfil the relevant cultural desire of the consumer (or user). As with all architecture, historical architecture exists of a time, and is relevant for such time. As a cultural product, architecture addresses an objective which is temporal and the anticipation of its influence does not project beyond the point of current occupation: it is utopian (Scott, 2008: 15) and therefore unwilling to change.



“Change of use causes a massive change in the rituals of occupation. Buildings change as the city changes”.
(Scott, 2008: 17)

Architecture exhibits a sense of permanence. Buildings survive beyond their destined purposes and change in occupation is inevitable. To address this, buildings may be retained and altered or they may be demolished and replaced. Feilden argues for the conservation of historical architecture as “cultural property” (1994: 8) but rejects new occupation. Interior design, as a reaction to existing built form (König, 2010: 50), would opt to retain and alter the existing. These conflicting ideas have given rise to the following research question:

1. How can the value of existing historical architecture be improved through intervention?

And sub questions:

1.1 What is the role of historical architecture in cultural production?

1.2 Can the interior design intervention adequately address change in occupancy while maintaining the historical identity of the existing building?

I.4 DESIGN

The problem of focus will relate to the 1909 Chief Engineer’s Office (CEO) / 2011 People’s Upliftment Programme (POPUP) building in Salvokop and a re-approach to intervention since change of typology as a means to reinstate integrity to the original building and explicitly address its new purpose as a skills training centre for the disadvantaged. This study is significant to the context of Pretoria, a city which contains the real-world problem of large collections of historical architecture rendered obsolete due to change in occupancy.

The site and context were chosen according to a set of criteria as a means to overcome the unfamiliarity with the city of Pretoria and in order to respond to existing design and research strengths and interests. These criteria include:

- The chosen site and building should be of heritage significance and therefore of appropriate complexity (SACAP, 2010: 1).
- The chosen site and building should be accessible and documentation of the area (history, frameworks, maps, drawings, etc.) should be available.
- The chosen site and building should find itself in a defined urban context (a defined urban context is regarded in the study as a setting which includes a diversity of activity nodes and built functions within the given precinct).
- The chosen site and building must have distinctive qualities, worthy of preservation and useful as a positive contribution in the process of design.
- The chosen site and building should display a sense of missed opportunity to be addressed in the design.

The neighbourhood of Salvokop (Illus 1.2) appeared to meet these criteria and had the most appeal as an historical settlement associated with the railway development of Pretoria. Freedom Park is of note in this instance, since it is a world heritage site (Freedom Park, s.a.) and is located within the immediate context. Its design concepts of a documentation of the past, present, and future of the South African people’s progress (Freedom Park, s.a.) should provide relevance and significance to both design and theory.



Illus 1.2 Aerial Photograph of Salvokop (Google Earth, 2010)



Illus 1.3 Chief Engineer’s Office, 1909 (Bakker, 2002)

The chosen building lies within a complex of historical buildings designed to service the operation of the railway line in the early 1900's (Astrup, 2005: 21-22). The chosen building, completed in 1909, was designed to accommodate the offices of the chief mechanical engineer for the Central South African Railway (Astrup, 2005: 24) (See Illus 1.3). Presently, the building is occupied by POPUP, a skills training centre for the disadvantaged (Illus 1.4).

In order to motivate the necessity of a design intervention, a statement of significance has been prepared:

- As a building historically designed for the use of office workers in the early 1900's, the original design has little relevance to the functionality of a skills training centre for the disadvantaged of today.
- Similarly, the alterations and additions applied to the building to suit these new functions were conducted in a way which disregarded the aesthetic and spatial integrity of the original building, without adding design value to the operation of its current typology.
- However, the existing typology of a skills training centre is socially significant and worthy of retention since its role as a means to enable progress in people is of constant relevance, a positive contribution to society and meaningful to its immediate context of the impoverished Salvokop community, as well as Freedom Park, a monument concerned with the progress of South African people throughout time.



Illus 1.4 POPUP (Astrup, 2005:21)

POPUP, the identified client, is a charitable organisation, which is involved in imparting a variety of skills to the disadvantaged at the cost of a marginal enrolment fee with the goal of enabling them to generate an income (POPUP, s.a.). Existing skills classes last for differing time periods and are supplemented by a further 10 days of training in life orientation prior to the skills course (POPUP, s.a.). Skills training fields include: home management, catering, garment and décor manufacturing, early child development, home based care, computer and secretarial skills, arts and crafts, forklift driving, business skills and life skills (POPUP, s.a.). POPUP also provides social services, medical services, a crèche and foster care at the Edenvale site (POPUP, s.a.). Conditions for entry to skills programmes include: learners should be "between 18 and 45 years of age", they should be unemployed and "available daily for full-time studies", "no post-school qualifications or grade 12 is necessary" and learners must be capable of reading, writing and understanding English, with a compulsory written test to determine this (POPUP, s.a.).

The skills training centre will require designated spaces for the following existing skills training: home management (some practical training occurs outside POPUP centre), catering, garment and décor manufacturing, early child development, home based care (practical training occurs in Centurion), computer and secretarial skills, arts and crafts, forklift driving, business skills and life skills (POPUP, s.a.). Of these skills, forklift driving is the only one which is confined to the exterior and will therefore be regarded as secondary focus to programming of other skills training.



Illus 1.5 POPUP's Sewing Laboratory (Author, 2010)

All skill types require rooms for lecturing and some for practical experience (training laboratories). Lecture rooms will be non specialised and multipurpose, in order to suit the use of different skill types. Training laboratories will be specialised according to the relevant skills.

The following is required:

1. Lecture room/s (cooking skills, garment and décor manufacturing, secretarial skills, arts and crafts, business skills and life skills)
2. Food laboratory (cooking skills)
3. Sewing studio (See Illus 1.5) (garment and décor manufacturing)
4. Arts and Crafts studio (arts and crafts)
5. Counselling rooms (for POPUP learners, staff, street people, food applicants and local shelter inhabitants)
6. Ablutions
7. Dining Hall (for meal provision to POPUP learners)
8. Staff Offices
9. POPMed, POPEye and POPDent constitute an on-site clinic for the disadvantaged and will be disregarded from the scope of study.
10. POPKids is a crèche for disadvantaged and community children and will also be disregarded from the scope of study.

The entire building will be considered as the site for intervention. Although the clinic and crèche will not be considered as the focus of the study, these may be appropriately rezoned should this be required.

1.5 METHODS

As part of the research study to be conducted, the combination of qualitative and interpretive historical research methods are intended to be implemented. Qualitative research involves the act of subjective, interactive research with which the researcher is strongly engaged (Groat & Wang, 2002: 28). It is an inductive process of inquiry which entails the exploration of factors before reaching a conclusion (Groat & Wang, 2008: 28). Qualitative research is concerned with the interpretation of information, rather than the acceptance of facts.

The grounded theory method, as a sub category of qualitative research, will be utilised specifically and involves an “open ended”, “iterative” and “intensive” procedure of “data collection”, “coding” (analysing information) and “memoing” (“theory building”) (Groat & Wang, 2008: 181). This requires the researcher to enter the study without preconceptions, and rather, allow the process of data collection and analysis to generate theory (Groat & Wang, 2008: 180). It is a cyclic process which demands continuous re-evaluation, connection and recollection between the phases of data collection, coding and “memoing” as expressed in the diagram alongside (Table 1.1) (Groat & Wang, 2008: 182).

The interpretive historical method of research will also be employed as a secondary research method. This method was chosen because of the heritage significance of the chosen site. This process of research will involve the collection of historical data, (photographs and aerial photographs) and organizing and interpreting these (Groat & Wang, 2002: 137). This will be used as a form of contextual analysis and discovery as outcomes for the design process, and in determining the significance of the building. These will manifest in time lines, photographic analysis and mapping exercises. Historical interpretive research is linked to the act qualitative research (Groat & Wang, 2008: 167), making it a viable choice in combination with the grounded theory method.

A design method to be initiated is the stripping back method as outlined by Fred Scott. The stripping back method involves the removal of “rotted fabric” (alterations and additions to the building) , replacing and repairing the original fabric, and “enabling works”, the removal of portions which hinder new purpose and the introduction of portions which enable this (Scott, 2008: 108) (Illus 1.6).

The process requires that the designer gains explicit knowledge of the “host” building (Scott, 2008: 108), to be achieved through the process of determining its ideal or model form (Scott, 2008: 109) in analysis.

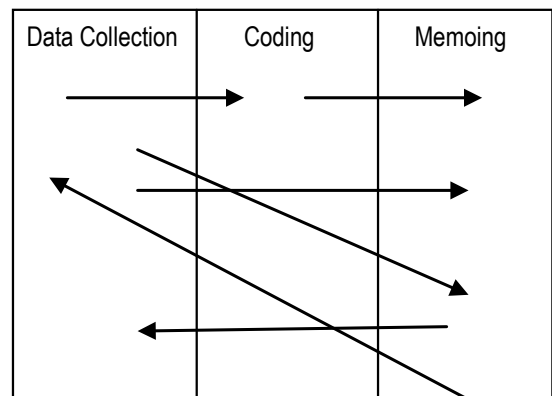
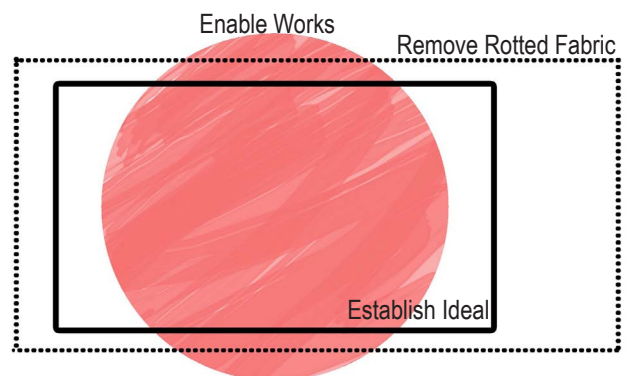
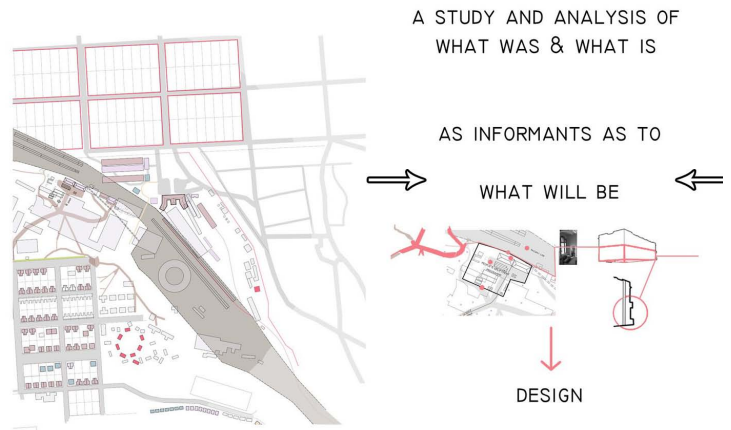

Table 1.1 Grounded theory research phases (Groat & Wang, 2008: 181)



Illus 1.6 Stripping Back Method Parti Diagram (Author, 2011)

Reading the Existing



Other methods to be implemented are symbolism, permanent and temporary, and reading the existing as guidelines for the design intervention. These are illustrated and described below in Fig 1.1.

Other design tools to be implemented include contextual studies, precedent studies, mood boards, collages (as a “compositional tool for intervention” (Scott, 2008: 156)), collection of current and past evidence (newspapers, magazines, maps) and the use of models (as a means to determine stripping back, replacement and removal of fabric).

The following limitations are identified: The building may only be accessed during its operational hours. The design and research study will be conducted in the space of a single year and therefore, only a portion of the built intervention maybe detailed. The existing building will be considered as the site for intervention and the functions of a clinic and crèche maybe rezoned according to spatial requirements, but will not be considered as the study focus.

The design proposal will occur within the context of the following assumptions: All of the proposed Freedom Park buildings are complete and operational. The design will act under the assumption that the Gautrain system and station is operational. Framework proposals for Salvokop will be reviewed and selectively incorporated within the group urban framework within which the design will find context. The building’s structural condition is currently stable.

I.6 CONCLUSION

This chapter has served to introduce the study topic. The study background and theoretical context have been outlined and the research questions identified. The chosen site, typology and client have been introduced. The research and design methods have been outlined and the limitations and assumptions denoted. The chapters to follow will strive to supplement and represent the design and research goals outlined.

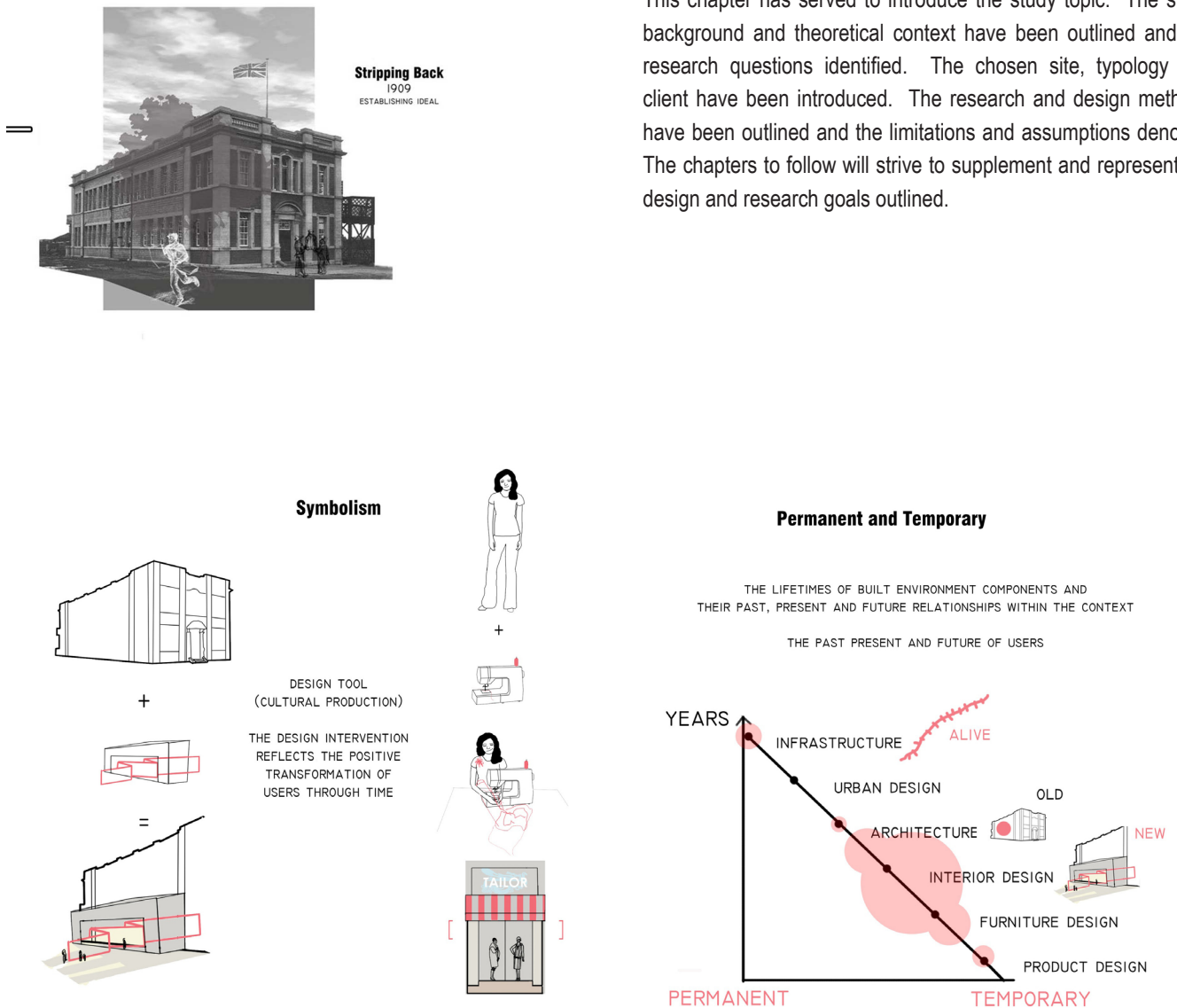
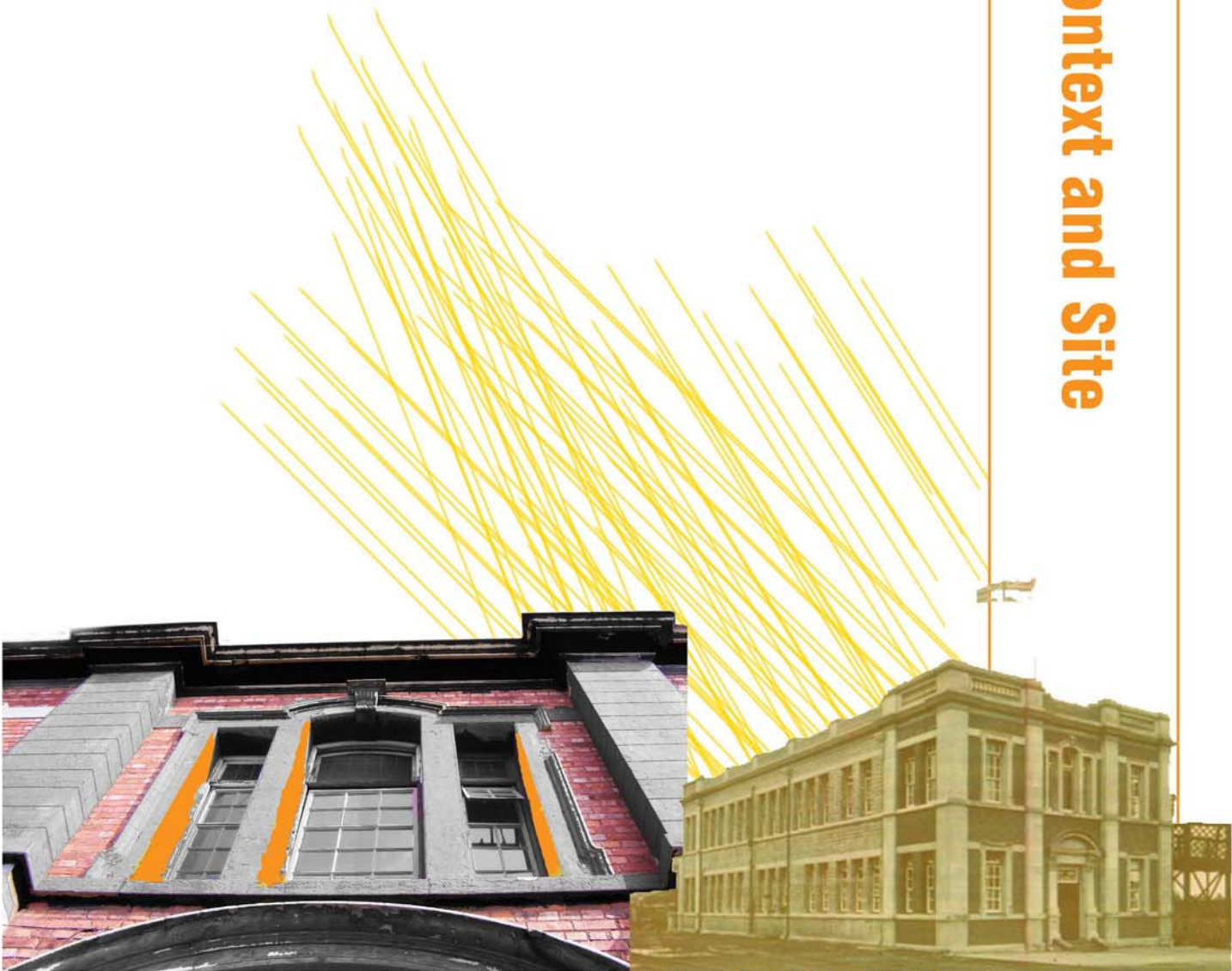

Fig 1.1 Design Methods (Author, 2011)



Illus 2 2011 POPUP (Author, 2011) and 1909 CEO (Bakker, 2002) edited by (Author, 2011).

2.1 INTRODUCTION

This chapter will serve to elaborate on the project context and site. Firstly, a broader contextual locality will be provided, highlighting the position of Salvokop, the area of study, within a greater context. Thereafter, the area of Salvokop will be explained and its significance highlighted. A historical time line for the Salvokop region will be provided as being especially significant to the individual design process. Finally, the group framework proposal will be introduced.

The remainder of the chapter intends to clarify an understanding of the chosen site. The site is defined in focus on a number of scales. Since the 1909 CEO / 2011 POPUP building finds context in a number of scales, it is these contexts which will be explored and analysed. The study will consider both, the entire POPUP site, and the 1909 CEO / 2011 POPUP building.

Analysis and outcomes will be explained. The chapter will then be concluded with the impact of these exercises on the design project being highlighted.

2.2 GREATER CONTEXT

The laboratory of study is located in Pretoria, South Africa. The neighbourhood of Salvokop is within immediate proximity of the city centre of Pretoria.

The region of Salvokop is located south of Pretoria's central business district (Illus 2.1). Its current programme predominantly consists of low density housing in historical railway houses as well as informal structures. Freedom Park, a world heritage site, is located south of the residential neighbourhood and overlooks the city of Pretoria. The sub-urban context of Salvokop also contains a day care centre, a primary school, several shebeens and the People's Upliftment Programme, as a social upliftment node.

Access to Salvokop from the city is limited to a pedestrian bridge alongside Pretoria Station and vehicular entrance through Skietpoort Avenue. Currently, no public transport arrives within Salvokop, with the nearest stop occurring at the station.

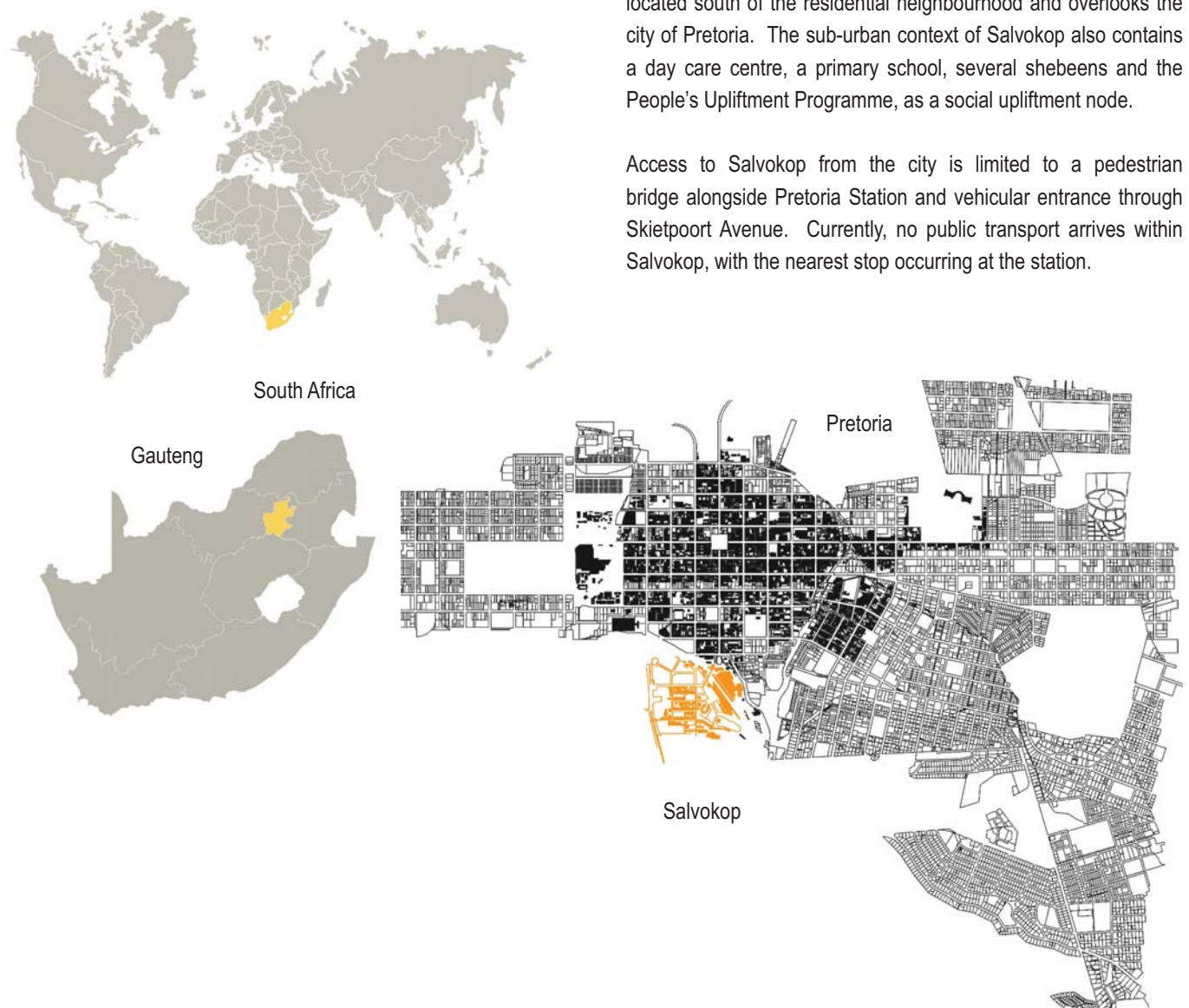

Illus 2.1 Locality Maps (Author, 2011)



Illus 2.2 Aerial photo, Salvokop (Google Earth, 2011) edited by (Author, 2011)

The positive contextual characteristics have been identified as:



Illus 2.3 Residential Character (Author, 2011)

1. Residential (Illus 2.3): The historical railway houses of Salvokop provide a distinct character to the neighbourhood. Their scale, relationship with the street edge and interior to exterior transition (stoep) all form positive urban characteristics in this neighbourhood, creating a pleasant pedestrian environment.



Illus 2.4 Breathing Space
(Google Earth, 2011) edited by
(Author, 2011)

2. Breathing Space (Illus 2.4): The neighbourhood of Salvokop can be strongly characterised by the substantial landscape buffer between the city and Salvokop, along the edge of the railway line. This green space isolates Salvokop and protects it from the noise, pollution and traffic of the city.



Illus 2.5 Historical Character (Author, 2011)

3. Historical (Illus 2.5): The neighbourhood of Salvokop was developed to service the railway line from the 1880's. The settlement's legacy of historical architecture and infrastructure remnants has partially survived. Currently, while many historical buildings still exist, their presence is threatened by the development of the new Gautrain station along the railway line, access routes to Freedom Park and lack of maintenance. These historical structures include two typologies of railway housing, the 1909 Chief Engineer's Office (now occupied by POPUP), an abandoned shed along and several obsolete railway lines.



Illus 2.6 Ecological Systems
(Google Earth, 2011) edited by
(Author, 2011)

4. Ecological Systems (Illus 2.6): The ecologically diverse landscape systems in this region have been predominantly destroyed due to lack of maintenance. The restoration of these historical landscapes has been partially addressed in Freedom Park (Freedom Park, s.a.). This provides opportunity for precedent in landscape rehabilitation and the creation of green urban spaces.

2.3 HISTORICAL CONTEXT

The time line (Table 2.1) illustrates the significance of the railway to the building’s individual historical context. The loss of a typological relationship to the railway line has also led to a physical loss of connection. This provides the opportunity for site development which involves and encompasses the railway edge. The revival of railway interest through the Gautrain development and station opposite the railway line from the site creates a possibility for a renewed railway connection which assumes new technology, symbolises progress and is of immediate relevance.

A record of building development through time has been mapped as demonstrated alongside in Illus 2.7.

The mass demolition of fabric in the maintenance yard is of note and could provide design direction, especially with regards to expressing memory.

This map contextualises the relationship between the 1909 Chief Engineer’s Office and other built fabric in Salvokop over time.

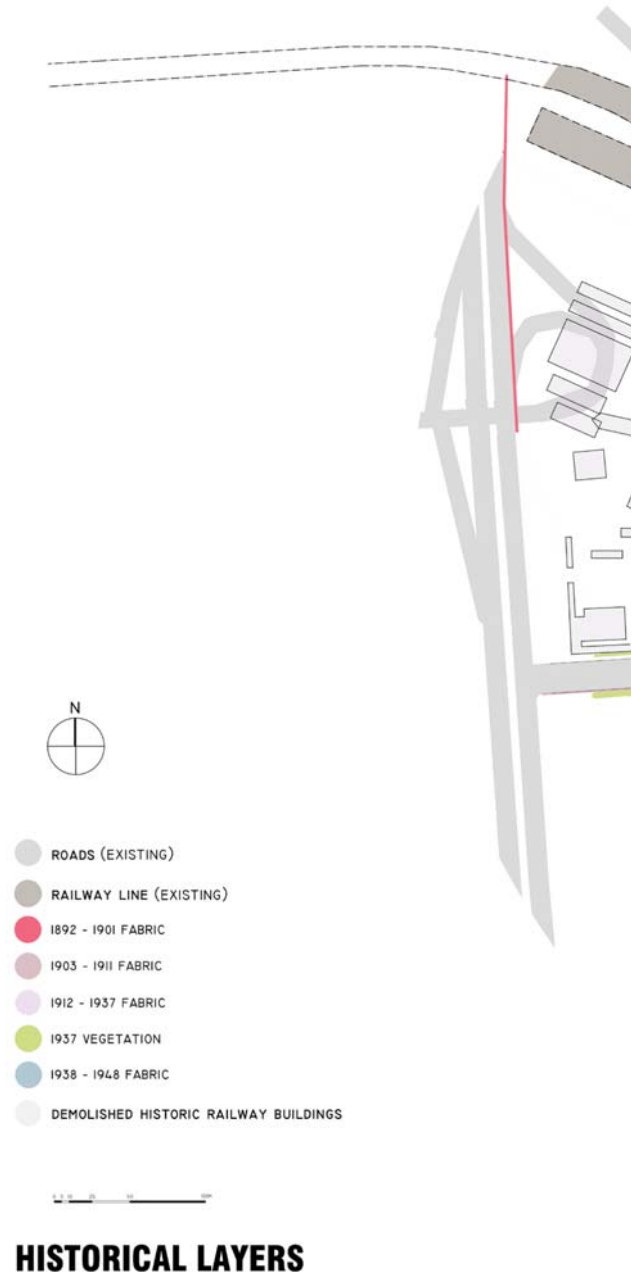



















Illus 2.7 Time Mapping, Salvokop (Author, 2011)



Year	Event	Image
1855	Pretoria is named capital of Transvaal	
1877	Pretoria becomes a seat of British control	
1881-1882	Anglo Boer War	
1883	Paul Kruger gains permission from Portugal to run a railway line through Mozambique	
1886	Discovery of the Rand Gold Reef creates ample capital for railway development	
1887	Nederlandsche Zuid-Afrikaansche Spoorweg Maatschappij (NZASM) is established	
1888	NZASM's first building (engineer's residence) is built on the corners of Minaar and Paul Kruger Streets	
1895	Pretoria - Pietersburg Spoorweg Maatschappij (PPSM) is formed to create a line between Pretoria and Pietersburg	
1899	Telegraph Office Building completed	
1899	Second Anglo Boer War: South African Republic (ZAR) takes control of railway, workshops are used to create weapons	
1902	Peace is achieved, PPSM, NZASM and the Free State Railway combine to form the Central South African Railway (CSAR)	
1903	Completion of Findlay Reservoir: First Municipal Water in Salvokop and Pretoria	
1909	Chief Engineer's Office is completed	
1910	CSAR, Cape and Natal railway administration merge to form South African Railways and Harbours (SAR [&H])	
1912	Pretoria Station, designed by Herbert Baker, is completed	
1920s	Demolition of NZASM station buildings	
1925	Re-erection of Paul Kruger statue in Station Square	

Table 2.1 Time Line, Salvokop (Bakker, 2002) formatted by (Author, 2011)

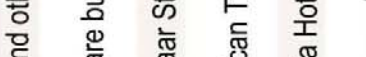
Railway Audit Building constructed	1928	
Belgrave Hotel (Art Deco style) is built	1929	
SAR & H at its busiest, many new constructions in railway zone and camp	1912-1950's	
Sunken gardens in Pretoria Station are completed before 1947 royal visit	1946	
Relocation of compound workers to Mamelodia and other townships (Apartheid)	1948-1955	
Last Salvokop houses are built	1960-1970	
Demolition of NZASM offices on Minaar Street	1961	
Administrative organisation of railways become South African Transport Services (SATS)	1981	
Rovos Rail Headquarters in Victoria Hotel	1989	
Transnet is established, closure of uneconomical lines.	1990	
NZASM centenary celebrated by Transnet	1995	
Freedom Park Trust Framework	2001	
Paul Kruger Street Spine Spatial Framework	2001	
Pretoria Station burnt by angry commuters	2001	
GAPP/MMA Framework	2002	
Freedom Park is completed	2008	
Gautrain Station to be completed	2011	

2.4 URBAN FRAMEWORK

The group framework, “Preserve Connect” aims to react to the existing positive characteristics of Salvokop as well as to establish a connection between Salvokop and the city.

The framework map, Illus 2.8, indicates “connect” through increased access points between Salvokop and the city, mixed use development, commercial development, and a new high street. “Preserve” involves optimising the character of the current residential, ecological and historical zones and the breathing space.

See Appendix A for further framework analysis.

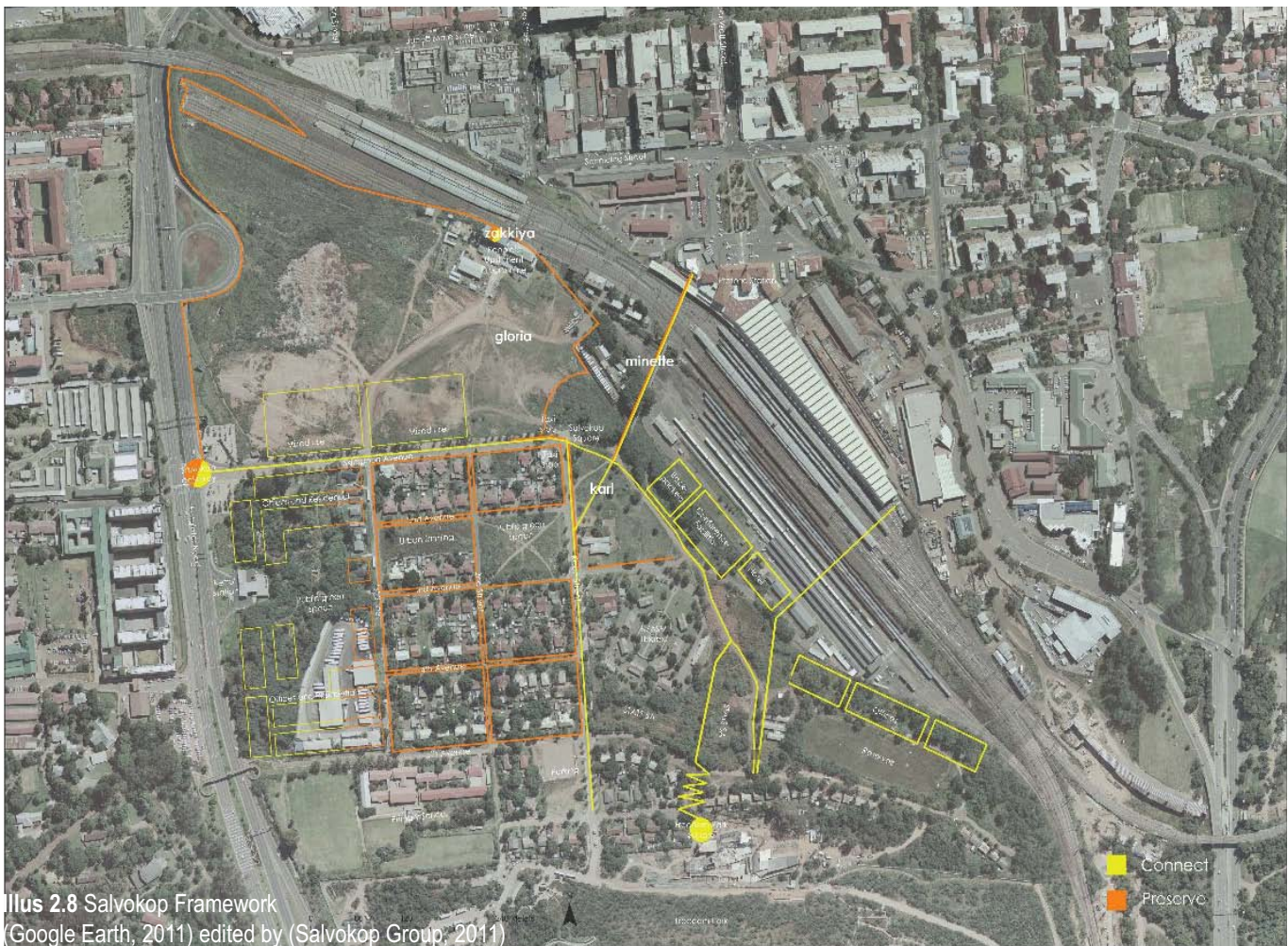

Illus 2.8 Salvokop Framework
(Google Earth, 2011) edited by (Salvokop Group, 2011)

2.5 SITE ANALYSIS

The following site analysis (Illus 2.9, Illus 2.12) is limited to the boundaries of POPUP's site. The analysis identifies the existing allocation of programme on POPUP's site and analyses the site through the following categories: Urban to Interior (Illus 2.10), Sense of Place (Illus 2.11), Internal Spatial Quality (Illus 2.13), Space and Use (Illus 2.14), and Alterations and Additions (Illus 2.15). The analysis is represented through identification of strengths, weaknesses opportunities and threats and extends itself to the interior of the 1909 CEO / 2011 POPUP building.

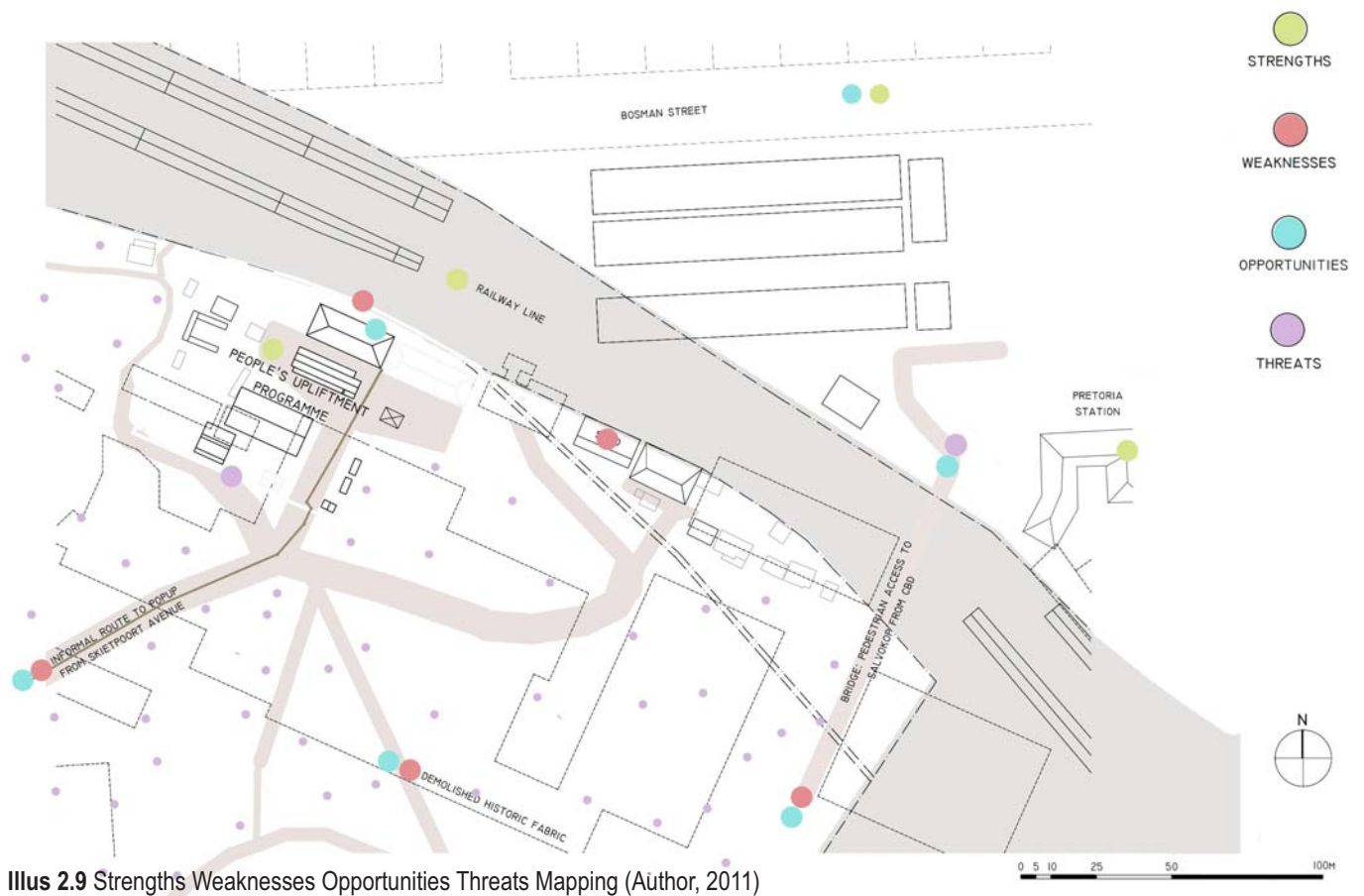

Illus 2.9 Strengths Weaknesses Opportunities Threats Mapping (Author, 2011)

2.5.1 Urban to Interior (Illus 2.10)

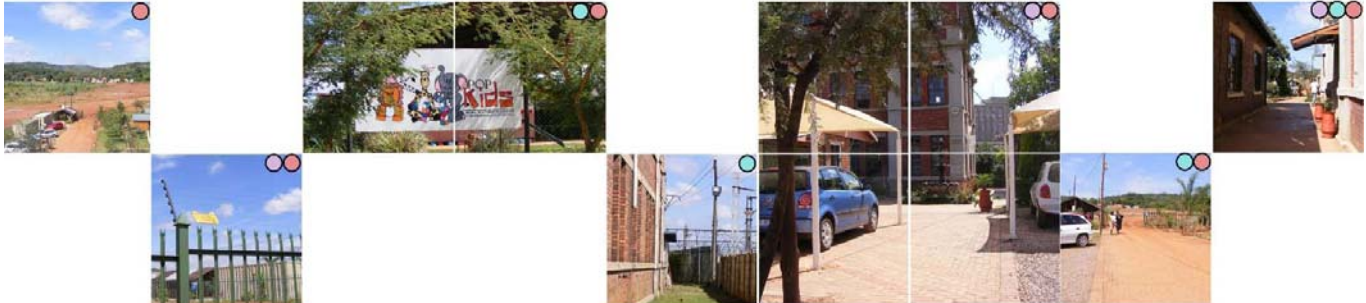

Accessibility

POPUP's site is accessed from the South through an informal dirt road. Its site is located along the railway edge and is isolated from the nearest street (Skietpoort Ave) by the unprogrammed landscape described as the "breathing space" in chapter 2. Its accessibility is visually and physically poor. POPUP's site is completely fenced, further removing it from its context.

Way Finding

Way finding is dependant on literacy as all indication of POPUP's presence is indicated through signage, only in English. There is no indication of programme allocation on the site apart from a sign indicating the crèche.

Environment

POPUP's site is disconnected and buildings are scattered and isolated. Structures range from permanent and load bearing (brick and concrete) to lightweight and temporary (portal frames and prefabricated classrooms). The railway environment is not acknowledged.

Presence

The 1909 CEO / 2011 POPUP building is crowded by carport structures, the brick medical clinic and the brick services and soup kitchen buildings alongside.

Entrance

There is a poor sense of entrance to any of the buildings since they exhibit poor relationships to each other. The entrance to the 1909 CEO / 2011 POPUP building is overcrowded by the services and soup kitchen building, a wasted opportunity given the hierarchal elements celebrating the entrance, symmetry and axis.

Illus 2.10 Urban to Interior (Author, 2011)



Illus 2.11 Sense of Place (Author, 2011)



Illus 2.12 Aerial photo of POPUP's site and programming (Google, 2011) edited by (Author, 2011)

2.5.2 Sense of Place (Illus 2.11)

Views and Vistas

POPUP's site displays potential for the incorporation of views and vistas. From the 1909 CEO / 2011 POPUP building, immediate views to the railway line, as well as distant views to Salvokop's neighbourhood are available but under utilised. Interior vistas include the staircase, which is open and visible from the lobby of each level in the building. The staircase is a beautiful building element with arts and crafts influence.

Heritage Response

The building, although having been restored partially in 2002 (Bakker, 2002) is still incomplete in a sense. The historical bridge leading from the building across the railway line had been removed. Its void has been uneventfully enclosed by a sheet of shutter board, posing aesthetic and safety threat to the building.

Social Response

POPUP is a charitable organisation that is concerned with social upliftment through health care, skills training, food and clothing donation and child care. Although its ideals are admirable, its site is unaccessible, difficult to navigate and unwelcoming since it is barricaded and there is no sense of entrance.

Railway Response

POPUP's site does not address the railway edge. It is removed from its context and chooses to fence itself in as opposed to integrating with its historical connection to the railway line. The Gautrain Station development on the opposite side of the railway line provides the opportunity to revive this connection and interest to the building and POPUP's site. Although the site is located along the railway edge, frequency of trains through the day are minimal and the noise from these momentary, providing little disturbance.

2.5.3 Internal Spatial Quality (Illus 2.13)



Strengths Weaknesses

Light and Volume

The 1909 CEO / 2011 POPUP building exhibits excellent consideration for natural light and volume. Its high and frequent windows allow the passage of natural light into the building. The ground and first floors are double volume, creating a sense of public hierarchy. The open staircase, emphasises the building volume and is surrounded by windows and well illuminated. The 2nd floor, an addition to the building in the 1950's represents a weakness in this regard. It is single volume, enclosed, depends on artificial light during the day and has no visual connection to the exterior, making it a threatening environment.

Materials

The historic materiality of the building has been partially preserved, restored (windows and frames) and replaced (floor tiles). The original floor finish of terracotta tiles still cover most of the floors. Other floor areas have been finished with vinyl, screed and ceramic tiles. Walls are brick and mortar finished with plaster and paint. The third floor also contains wood panel partitioning. The staircase balustrades consist of carved varnish posts and cast iron filling.

Thermal Response

The building is naturally ventilated through windows. Passages pose a potential problem in ventilation, being far from windows and could require assisted ventilation. The building is thermally comfortable.

Illus 2.13 Internal Spatial Quality (Author, 2011)

2.5.4 Space and Use (Illus 2.14)

Flexibility

The rectangular floor plan of the building implies versatility since it is not prescribed or particular. The double volume creates opportunity for the development of new mezzanine spaces. The symmetrical structure and frame and infill system can allow ease of removal of fabric and expansion.

Hierarchy

The building facade displays strong hierarchal sense of entrance and arrival through ornamented openings. Once inside the building, however, an idea of public to private spaces is only understood through signage and is otherwise implied by seating furniture in the lobby of each floor.

Signage

Signage style varies from temporary to permanent and does not have a sense of continuity in the building. Its locality is inconsistent on each floor. Signage on the third floor, brushed aluminium wall mounted rectangular signage, is more permanent, informative and tactile.

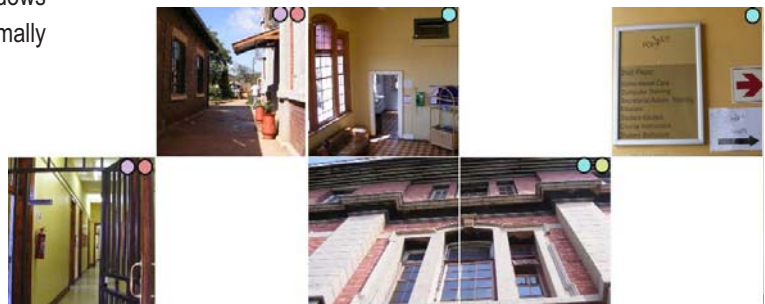

Illus 2.14 Space and Use (Author, 2011)

Opportunities Threats

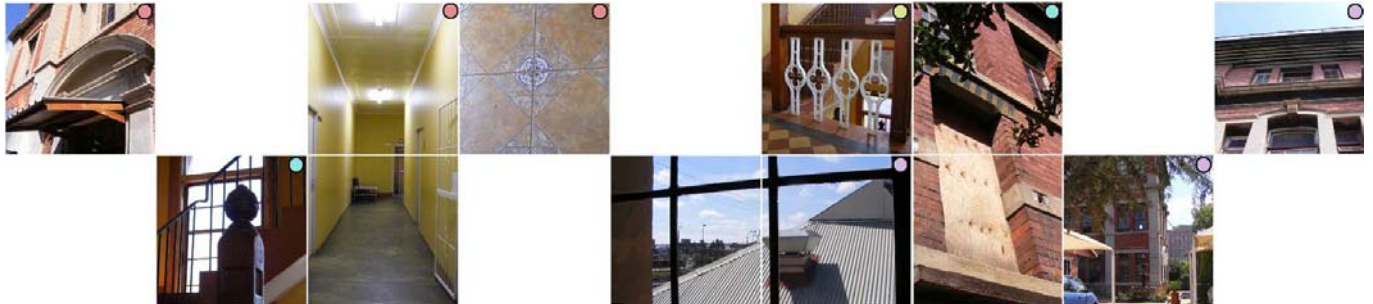

2.5.5 Alterations and Additions (Illus 2.15)

Illus 2.15 Alterations and Additions (Author, 2011)

Ergonomics

There is no definite consideration for ergonomics in the building. The restriction of affordability has controlled many decisions in terms of furniture and alterations in the building. The 1909 CEO / 2011 POPUP building displays sensitivity to user comfort through its large windows providing views across the railway line. The staircase is comfortable, although the balustrade height is low and poses a safety risk.

Inclusive Design

The building is exclusive in terms of access. The fenced in plot is not welcoming. Circulation to the upper floors of the building is limited to the staircase which is problematic for wheelchair users.

Access to Facilities

The building facilities are adequate and well-maintained. Water closets are found on each floor. They are, however unisex, which could be threatening and uncomfortable to the users. Pay phones are also available within the building. This is a valuable resource since users are low income and probably do not own personal cellular phones.

Restoration

The building has been restored in several areas. Extensive restoration of timber door and window frames have occurred. Some doors have also been restored. Several portions of the concrete door and window ornament have been restored.

Preservation

The building has been preserved in several aspects: the terracotta tiles, the staircase and its cast iron fill have been preserved.

Removal

A bridge from the building across the railway line to Scheiding Street had been removed. The void has been covered with a shutter board sheet.

Addition

The addition of a second floor occurred in the 1950's. The parapet gables were used as a means to inform the continuity of the facade. A gabled roof on timber trusses now caps the building. The enclosure of the portico on the west of the building occurred concurrently.



2.6 ESTABLISHING IDEAL

The stripping back method, as outlined by Fred Scott (2008: 108) has been considered as the design method for treating the altered building. The process of stripping back involves three stages, the first of which is “establishing the ideal” (Scott, 2008: 108). The ideal is defined as the building’s utopian form, its original vision. To determine the “historical ideal” of the 1909 CEO / 2011 POPUP building, an analysis of the building’s early image has given rise to the recognition of its major design elements. The figure alongside (Illus 2.16) illustrates these principles in diagrams. The historical character pertaining to these principles are predominantly evident on the building facade.

Also illustrated is the building’s internal staircase (Illus 2.17), identified as an “ideal” element as a result of its distinctive character and balustrades of arts and crafts style. The application of terracotta tile finish on the staircase and first floor are notable.

Site character is depicted overleaf in Illus 2.18 (page 30).

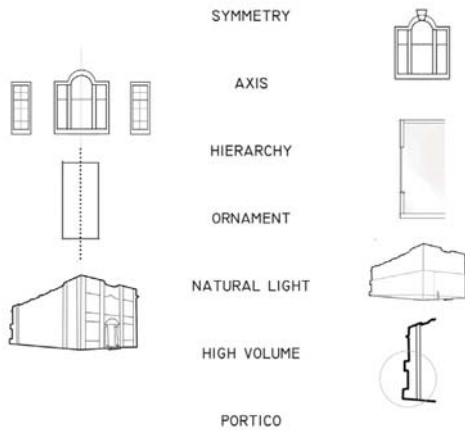

Illus 2.16 Establishing Ideal (Author, 2011)

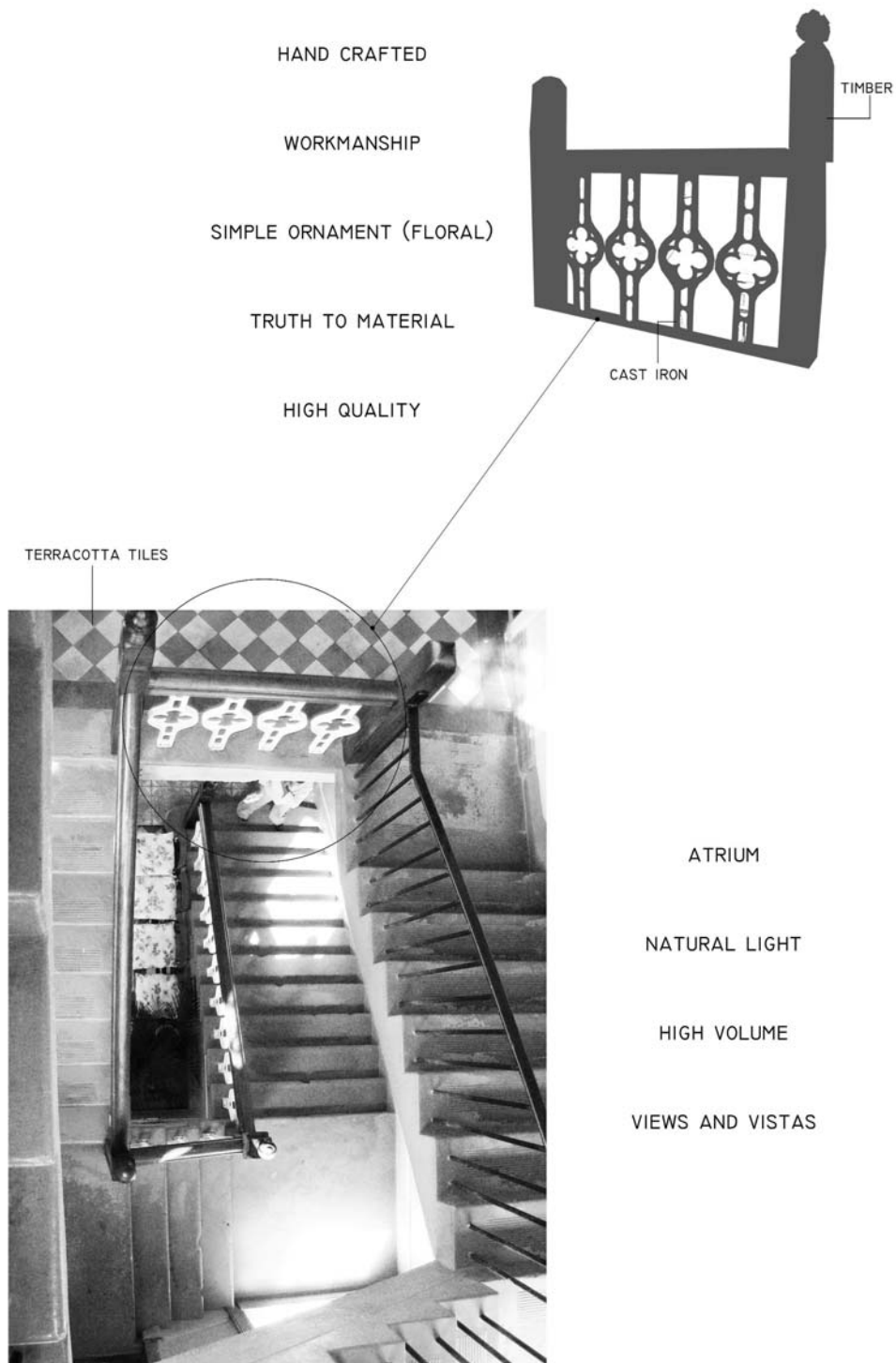

Illus 2.17 Establishing Ideal (Author, 2011)



2.7 CONCLUSION

The contextual analysis has served to highlight the distinctive characteristics of the neighbourhood of Salvokop. These observations, are recognised as providing a notable sense of place, worthy of preservation and deserving of emphasis. The framework strives to achieve this by using the existing as a means to react.

The historical mapping and time line of Salvokop highlight its significance as an historical landscape, associated predominantly with the railway development. The survival of some of these historical structures and settlement have become a strong contributor of the neighbourhood character and are to be protected and emphasised by the framework proposal. The extensive demolished fabric of the maintenance yard is to be expressed in memory through abstract elements.

The contextual study provides crucial relevance to the individual study concerning the 1909 Chief Engineer's Office / 2011 POPUP Skills Training Centre, through its findings historically and characteristically. The results lend strongly to the conceptual methods of "reading the existing" as a means to generate design response through reacting to what is, "palimpsest", as a means to express the memory of lost and demolished fabric and "symbolism" to represent the past relationship with the railway, which forms a significant part of the building's history.

The framework study is relevant to the individual study in its ideals of emphasising the existing, which coincides with "reading the existing". The framework will serve to establish a character and contextual atmosphere in which the building will find connection. Access, green spaces, circulation and axes will influence and be influenced by the framework proposal.

An extensive analysis of the 1909 CEO / 2011 POPUP building has been conducted. The strengths, weaknesses, opportunities and threats of the building and the arrival to the building has revealed openings for design potential to rectify or optimise the existing. A sense of connection between the building and its physical and historical contexts is unaddressed and should be considered in the design process.

The building's ideal (distinctive historical characteristics) has been established. This process has clarified the vision of the building as the 1909 CEO and its intention can be revived through the process of stripping back while considering the change in typology, user and time.

The documentation of rotted fabric and its intended removal will be reflected in further analyses and design drawings. The process of enabling works will be further explained in the design chapter.

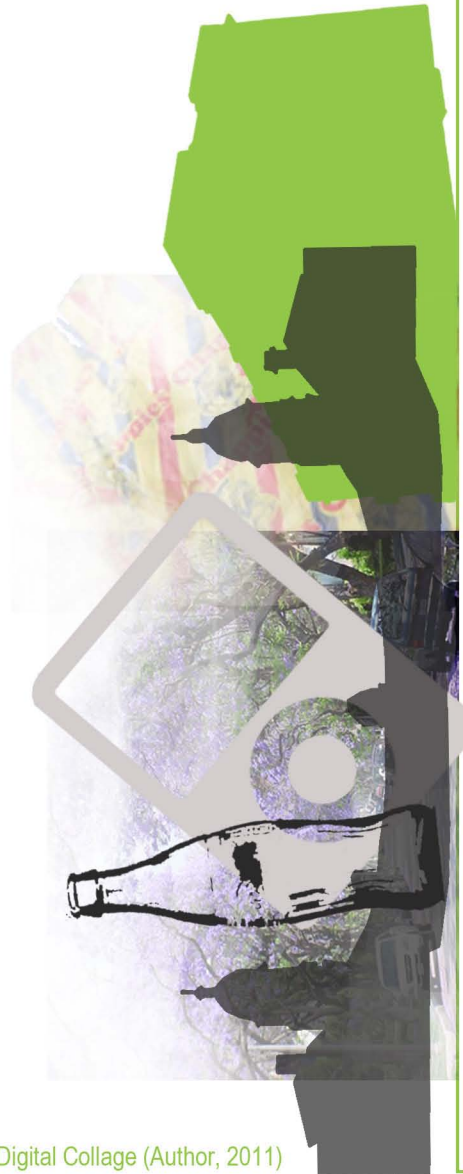

Illus 3 Cultural Products: Digital Collage (Author, 2011)

3.1 INTRODUCTION

This chapter will elaborate on the theoretical framework through which the design project will occur. The legislative and international guidelines influence on the design will be identified and explained.

Thereafter, the theory of cultural production and its relevance to the design will be expanded upon.

Means of building alteration will be explored and also expressed diagrammatically. The stripping back method will be explained and interpreted. The roles of legislation, guidelines, theory and modes of alteration will be identified in the stages of stripping back with design outcomes identified.

The chapter will then be concluded.

3.2 LEGISLATION AND GUIDELINES

3.2.1 National Heritage Resources Act (NHRA)

The act is concerned with the conservation of heritage resources for the benefit of present and future generations, acknowledgment of the past and its significance as an inherited identity which is not renewable (South Africa, 1999: 3).

The NHRA is of significance to the project since it is South African legislation and is therefore relevant to the geographical and historical context. It deals with the management and attitudes to heritage resources as opposed to any design approach regarding these.

The following principles form a basis for the design project:

- Protect historical structures for present and future generations (South Africa, 1999: 17).
- Promote the use of and access to heritage resources (South Africa, 1999: 17).
- Use existing historical structures for social and economic contribution. (South Africa, 1999: 17)
- Research, document and record historical resources (South Africa, 1999: 17).

The NHRA classifies heritage resources within three grades:

Grade I - Heritage resources of exceptional qualities that are of national significance (South Africa, 1999: 18) example, Union Buildings, Freedom Park.

Grade II - Heritage resources of a national state that have provincial and regional significance (South Africa, 1999: 18) example, Cradle of Humankind.

Grade III - Any other heritage resources worthy of conservation (South Africa, 1999: 18).

The 1909 CEO / 2011 POPUP building is classified as a grade II resource. It is of provincial importance, in its role as a building which serviced the historical railway development in Pretoria.

The NHRA states that no structure older than 60 years may be demolished or altered without a permit from the provincial heritage resources authority (South Africa, 1999: 58). This implies that any alteration intended on the 1909 CEO building (102 years old) would require permission and therefore motivation.

The NHRA's encouragement to share heritage resources for use and enjoyment (South Africa, 1999: 17) and to promote social and economic development (South Africa, 1999: 17) should be addressed by the programme of a skills training centre for the disadvantaged.

3.2.2 The Burra Charter - The Australia ICOMOS Charter for Places of Cultural Significance

This charter, which is to be utilised as a guideline to the design process, has the goal of conserving places of cultural significance, as a form of "tangible expressions of identity" for the benefit of present and future generations (Australia, 1999: 1).

The following guidelines will be adopted in the design process:

- Conserve places of cultural significance (Australia, 1999: 1).
- Document understand and interpret cultural significance (Australia, 1999: 1).
- Write a statement of significance (Australia, 1999: 10).
- In creation of new work, do not imitate the existing, new work must be identifiable (Australia, 1999: 7).

The charter advocates changing as much as possible to enable occupation, while changing as little as possible to retain the cultural significance of the place (Australia, 1999: 1). This approach is appropriate to the study which strives to address new occupation while maintaining the historical character of the building and its context.

3.3 CULTURAL PRODUCTION IN HISTORICAL ARCHITECTURE

Cultural production may be defined as the process whereby cultural products are created, diffused and absorbed (Venkatesh & Meamber, 2006: 1). This theory is relevant to the study since it addresses the role of cultural products in the life of its consumer or user. Interior design is a cultural product (Königk, 2010: 51). The designer is the producer of such product, the media, internet and advertising diffuse the product and the consumer or user absorbs this product, extracts meaning through perception and uses the product as part of their own identity construction (Venkatesh & Meamber, 2006: 4).

Cultural products are acknowledged as being highly relevant and specific to its market of consumers or users (Venkatesh & Meamber, 2006: 12) and are therefore temporal: product relevance expires after a time. Cultural products thereby become a form of evidence, providing insight and understanding of cultures of a time, and is of heritage significance to future generations.

Similarly, historical architecture, as a cultural product of its time, is evidence of cultural meaning to its consumers or users and becomes evidence of this. It is in this way that historical architecture is significant, in that it provides insight into the preferences, behaviour and tendencies of its users before.

Change in occupation (time, users and typology) poses a threat to the visions of historical architecture. Alteration considered from a functional perspective has led to the disregard of meaning created through the design of cultural products and subsequently, to a loss of value to the historical integrity of the building (Feilden, 1994: 8).

Similarly, through addressing change in occupation purely through functional alteration, the needs, habits and behaviour of the new user group is inadequately addressed due to the “make-do” approach to the existing historical structure.

This is the case in the 1909 CEO / 2011 POPUP building, as with many others in Pretoria. The result is a threat to both the historical host building and the new occupation (Feilden, 1994: 8), which are both irrelevantly considered through intervention.

Cultural production theory, therefore, becomes a relevant tool through which design can act in a means that addresses the explicit nature of changed occupation (time, consumer or user and typology) ensuring the survival of inhabitation in a building.

3.4 ALTERATION

Change in occupancy may be defined as a change within a building in time, user or typology. The 1909 CEO / 2011 POPUP building displays this situation of change in all three regards. This is demonstrated in Illus 3.1 below.

According to Scott (2008: 1), the fate of buildings, once completed, are either to remain unchanged, altered or demolished. If viewed from the perspective of the design project, the unchanging of 1909 CEO building would have resulted in a loss of occupation and thereby an empty building (Scott, 2008: 1). The building would remain unsuitable to the needs of a new time, user group or typology by remaining unchanged. The alteration of the building would result in inhabitation but does pose the risk of threatening the historical integrity of the building in its original vision (Scott, 2008: 1) as the 2011 POPUP building has done. Demolition would allow the opportunity for a new building as a cultural product particular to its occupation to be developed, but would serve to diminish the historical character of the area.

The social significance of POPUP and its location near the CBD motivates for its maintenance in occupation in Salvokop. It is known to users that the site is a point of social upliftment and health care. The building should therefore remain inhabited and not be restored to its intended historical vision without changing further if it is to maintain occupation. The 1909 CEO is historically significant in its role in the railway history of Pretoria. It is one of the few surviving buildings within the railway edge, and its demolition would result in a loss of historical character within Salvokop.

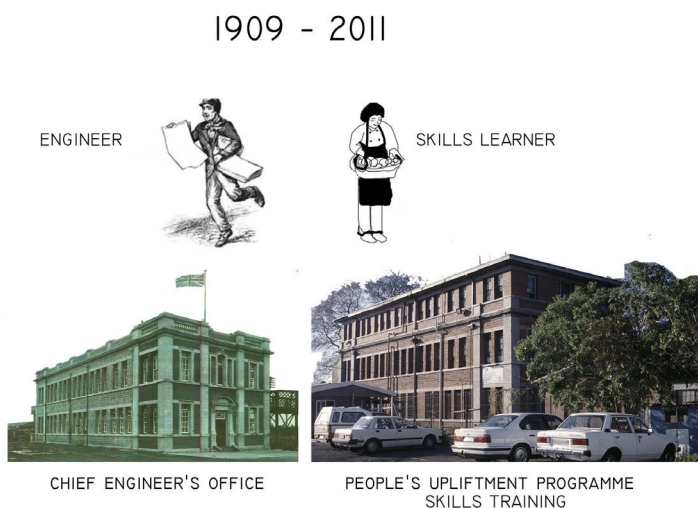

Illus 3.1 Change in Occupation (Bakker, 2002) & (Author, 2011)

The theory of alteration becomes a critical area of study in its relevance as the approach to historical architecture. Alteration will be conducted with the dual purpose of reinstating the historical integrity and character of the host building and addressing the new occupation (time, users, and typology) from the perspective of cultural production as an explicit representation of new occupation.

These four modes of alteration, adopted from the Burra Charter, will be interpreted and utilised to different degrees in the process of stripping back (Illus 3.2):

- 1 Reconstruction - returning a place to a known earlier state by introducing new material (Australia, 1999: 2).
- 2 Preservation - the maintenance of the fabric of a place in its existing state and retarding further deterioration (Australia, 1999: 2).
- 3 Adaptation - modification of a place in order to enable occupation (Australia, 1999: 2).
- 4 New work - the introduction of new additions and structures to enable occupation (Australia, 1999: 7).

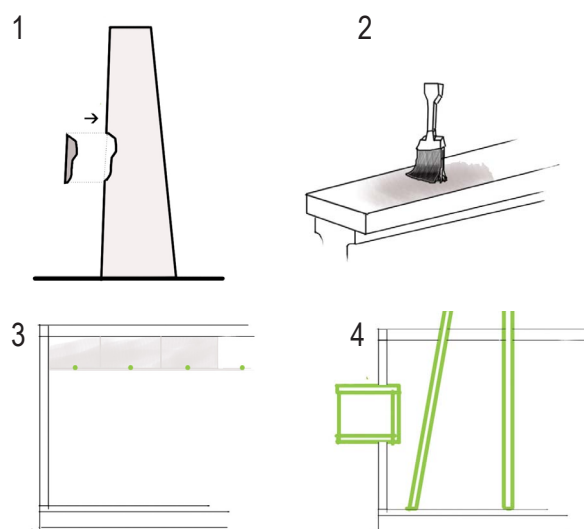

Illus 3.2 Alteration Processes (Author, 2011)

3.5 STRIPPING BACK

The stripping back method will be utilised as a means to guide the process of alteration to the 1909 CEO / 2011 POPUP building. The method provides a framework for action which will be supplemented by the theories discussed in order to add substance to the approach.

The stripping back method, adopted from Scott (2008: 108) involves three stages of approach to the host building. The host building is defined as the existing architectural product which is to be altered.

Establishing the ideal is the first stage of stripping back (Scott, 2008: 108). This involves the understanding of the host building (Scott, 2008: 108). The interpretation of this stage involves the identification of previous alterations in the form of restoration, removals and additions in determining how the building would have appeared in its first built form. This has occurred through the means of analyses of historical photographic evidence and visits to the building, which have been expressed in Chapter 2. The ideal has since been defined as the building in its first built form prior to any alteration. This stage of stripping back will be represented by graphic documentation of the ideal.

The stripping back method works within the intention of the building to return to its ideal (Scott, 2008: 108). This will be facilitated by the second stage of “removing rotted fabric” and “replacement of damaged fabric” (Scott, 2008:108). Rotted fabric has been identified as decaying fabric within the built structure as well as construction additions to the building subsequent to its ideal. These are to be removed (in order to return the building to its ideal) and ideal fabric which had been removed or altered is to be restored. Any fragile fabric is to be repaired and preserved as a part of the ideal building fabric.

These stages will serve to reinstate the historical integrity and character to the building and its railway context through reconstruction and preservation.

The third stage, entitled “enabling works” involves the creation of new fabric to enable new occupation. The new occupation, identified as 2011- previously disadvantaged skills learners - of POPUP skills training centre, will represent the change in the building to ensure inhabitation (Scott, 2008: 1). This will occur through the theoretical vision of interior design as a cultural product with the purpose of explicit and temporal intervention representing the needs, interactions and behaviour of users (Königk, 2010: 12). This stage will involve alteration and new work. The approach to these will be expanded on in the conceptual approach to the design.

The final stage will serve to address new occupation (time users and typology) through explicit representation from the perspective of cultural production.

3.6 CONCLUSION

This chapter has provided the theoretical framework from which the design project will occur. The legislative and guidelines context of the treatment of historical architecture has been outlined and the influence of these identified. The relevance of the theory of cultural production to the process of alteration has been highlighted in terms of addressing change in occupation. Different modes of alteration and their implementation in the design process have been identified. The design method of stripping back has been elaborated upon and specific means of approaching its stages in the design process have been mentioned.



Precedent & Case Studies



Illus 4 (Various)



4.1 INTRODUCTION

This chapter will serve to elaborate on several design precedents and case studies (personally visited) which have influenced the design project. These studies have been chosen according to the criterion of heritage interventions, cultural production and community upliftment. Each study will be critically analysed and the applicability to the design project will be emphasised.

4.2 HERITAGE

4.2.1 Rehabilitation of Santa Caterina Market, Barcelona (2005), by Enric Miralles Benedetta Tagliabue Architects (EMBT)

This project is concerned with the intervention to a deteriorating 1845 neoclassical rectangular building by introducing the new programmes of a produce market and housing for the elderly (Cohn, 2006: [99]). The site is located within the slum area of Barcelona's Gothic quarter, within close proximity to the Barcelona Cathedral, Picasso Museum and Ramblas. Although intersecting vehicular routes tended to detach the site from these iconic centres, the introduction of a new urban framework within this precinct opened opportunity for public access (Cohn, 2006: [100]).

EMBT's predominant design goal was to approach the historical fabric with the intention of preservation as an alternative to demolition, which is prevalent in the precinct (Tagliabue, 2006 in Cohn, 2006: [99]).

The design action occurred as follows:

Public access to the pedestrian was improved through the continuation of the pavement floor material, granite, to the interior of the market (Tagliabue, 2006 in Cohn, 2006: [101]).

The existing narrow streets were extended through the creation of crevices for points of entry to the market (Cohn, 2006: [103]). This increase in street width would serve to establish difference in hierarchy by implying public function.

The introduction of mixed use programmes which combine shopping and housing (Cohn, 2006: [100]) increases facilities for local residents and introduces new permanent (living) and temporary (shopping) activity in a previously abandoned space.

The introduction of a new undulating roof structure (Illus 4.1) implies new energy through contrast with the existing. It has the potential to act as a branding element, while colours symbolise the Mediterranean produce (Cohn, 2006: [103]), thereby reflecting what is inside the building. The roof creates new volumetric spaces inside and allows clerestory lighting at certain points along the facade (Cohn, 2006: [102]). Hand crafted trusses lend a sense of appropriation of space to the current user within an envelope which is of a different time.



Illus 4.1 Santa Caterina Market's colourful roof (Cohn, 2006: [100])



Illus 4.2 Santa Caterina Market street view (Cohn, 2006: [101])



Illus 4.3 Santa Caterina Market interior (Cohn, 2006: [100])

Although EMBT's rehabilitation of Santa Caterina Market does serve to introduce new use to abandoned, and slum areas, the success of the design intervention is heavily dependent on the success of the urban framework as a means to improve safety and increase public access to this region. The undulating roof is visually dominant from the street view (Illus 4.2) and demands attention due to its colourful tiles. This treatment is isolated and unique to the building and could serve to diminish the success and recognition of other public spaces within the precinct. Although the use of colour symbolises that of Mediterranean produce found inside the building, this treatment, as a branding element, has unclear meaning without explanation.

This project finds relevance to the design since it is also concerned with intervention to historical fabric. The use of symbolism of colour in the design is of critical value and can be utilised in the individual project with subtlety or obvious interpretations through colour, pattern and texture. The roof structure, as a reflection of the new intervention is also significant in that old is distinguishable from new work, a principle consistent with the guidelines of the Burra Charter (Australia, 1999: 7).

The use of the undulating roof has given rise to interesting light and volumes within the building's interior (Illus 4.3); principles which are to be implemented in the individual design. The use of rounded shapes and curving spaces challenge the rectangular geometry of the historical fabric and is representative of new energy in a previously decaying space. This exploration in the individual design is worthwhile since the 1909 CEO has lost relevance to the 2011 POPUP and a change in spatial perception might assist in appropriation to current occupation (user, time, programme). EMBT's attitude towards working with historical architecture through preservation, adaptation and new work as opposed to demolition is noteworthy and consistent with the views of the individual design project.

4.2.2 Ogilvy Offices, Durban (2010), by Egg Design

This project involved an interior design intervention to an existing classic revival building within the Point harbour area of Durban city. This building is an example of adaptive reuse projects prevalent within the precinct which convert warehouse spaces to offices and residential apartments. Ogilvy is an advertising agency which decided to settle its offices within this changing precinct due to its proximity to the city and its harbour views (Schauffer, 2011: 25).

The office's entrance was treated with bold, painted red strip along the exterior facade as an attempt to establish hierarchy and branding (Illus 4.4). This was done as a means to highlight the entrance to Ogilvy's office space along a block-long facade of other offices and residences (Schauffer, 2011: 25).

The design was predominantly influenced by connection to the harbour views through interior elements. The use of shipping containers as an envelope for the boardroom and the application of crate panels as a floor finish are among the visual elements utilised from the shipping environment (Schauffer, 2011: 26) (Illus 4.5).

Historical elements were interpreted through contemporary means to create furniture and finishes which are nostalgic but responsive to current trends. The use of floral carpets and laser cut Victorian profiles contrast the slick boardroom chair (Schauffer, 2011: 26) (Illus 4.6).

Although the building entrance is highlighted with a red strip, the impact to the exterior of the building is minimal. This branding element does establish hierarchy of entrance, but neglects in communicating the activities of the interior clearly and explicitly. Although Ogilvy's signage is placed along this facade, its role and function remains unexplained.

The use of shipping materials is regarded successful in establishing a low impact connection to the context using interior design.

This project finds relevance to the individual design since it is an interior design specific example of intervention to historical architecture within South Africa.

The 1909 CEO / 2011 POPUP can borrow the aspects of railway connection to the building through utilising discarded railway elements as material for finishes, product and furniture design. This can serve to re-establish the historical connection of the building to the railway development without imposing on the new programme of the building. The use of colour in hierarchy can be used to highlight circulation and distinguish between public and private spaces within the 1909 CEO / 2011 POPUP. The use of new processes, such as laser cutting, to imitate the intricacy and details of past design elements, such as the staircase cast iron infill will be considered as a tool for product and furniture design.



Illus 4.4 Entrance (Schauffer, 2011: 25)

Illus 4.5 Harbour Elements (Schauffer, 2011: 24)



Illus 4.6 Boardroom Materials (Schauffer, 2011: 26)

4.2.3 Cape Quarter, Cape Town (2007) by Archilab Architects

This design comprises of an adaptive reuse project which involved the conversion of an entire block of historical buildings into a new mixed use commercial centre (Cape Quarter, 2009) (Illus 4.7). The block was initially designed as rentable residential buildings for the poor in the early 1800's (Cape Quarter, 2009). In the 1850's, several buildings within the block adopted public and retail functions such as schools and stores (Cape Quarter, 2009). The building changed ownership two times which involved changes to other functions including breweries, apartments and brothels, until it eventually became Cape Quarter in 2007 (Cape Quarter, 2009).

The heritage approach to the block involved retaining and preserving the street facing facades and two structural walls of each of the block's buildings. The back walls have been removed to create outdoor shopping spaces which spill out to the back of the block seamlessly from the building interior. This interior exterior relationship (Illus 4.9) is considered successful since it opts to incorporate the courtyard space as a continuation of the shopping experience from entry to exit.

The treatment of the facade (Illus 4.8) was critical, since the design entailed the addition of a first floor within the existing space. The new facades, extended from the existing historical ones below, are predominantly glazed, contrasting the existing and allowing natural light into the building. The new facade design contrasts the existing facade to the extent that they are aesthetically isolated.



Illus 4.7 Historical Images of the block and users (Cape Quarter, 2009)

The historical fabric is preserved and unaltered, with poor transition to the contemporary new. The potential for a street front shop front along the historical facade is not exploited and seems to be a wasted opportunity.

The historical programme of the building is not considered. Most shops appear to be expensive and exclusive, ignoring the block's initial user group: the poor who were in need of accommodation close to the city. Although there is a craft workshop within the building, the target market for these products is the affluent. The Cape Quarter, in this way, rejects a sense of social responsibility to its user heritage.

This case study is of relevance since it is a contemporary intervention on historical architecture within the South African context. Although the facade treatment acts in isolation to the existing facade, the opportunity for using windows as opposed to hard fabric on upper levels allows the distinction between old and new, while changing the character of interior space by adding natural light. The opening of the back of the block to a protected courtyard introduces the opportunity for usable space which is a continuation of the interior. This principle may be utilised along the railway edge of the 1909 CEO / 2011 POPUP which is currently enclosed and introverted. The spilling of activity to the exterior may be a branding element, enhance user experience and provide opportunity for temporary interventions outside.



Illus 4.8 Cape Quarter facade (Author, 2011)



Illus 4.9 Interior Exterior Space (Cape Quarter, 2009)

4.2.4 TATE Modern, London (2000) by Herzog and De Mueron

This project entailed the alteration of an existing historical building previously used as the Bankside power station (Craig-Martin, 2000: 14). It was decided that the abandoned building be transformed into a new gallery for modern art (Craig-Martin, 2000: 15). Due to its central location, large scale, transport accessibility and position along the river bank, the site was perfectly suited to the new gallery.

The building, previously intended for the industrial purpose of serving the district with power, was designed to house large machinery and plant equipment, resulting in free, high volume open spaces, creating suitable potential for re-inhabitation once the machinery was removed. (Craig-Martin, 2000: 15)

The intervention entailed the removal of machinery, the acceptance of the space within the Bankside building shell, and the introduction of a new five story structure of galleries, circulation and services. The intervention sought to accept the industrial character of the existing building and to incorporate this with the new design. A new skylight (light beam) was installed above the existing roof, and treated with glazing, but as a rectilinear form which communicates as new structure, while connects to the form of the old (Craig-Martin, 2000: 19) (Illus 4.10).

This project is relevant to the design project since it also involves intervention with new occupation on an historical, rectangular, solid building with a previous industrial relationship. Although the scale of the Tate Modern drastically exceeds that of the 2011 POPUP, its principles of interior re-purposing, maintenance of the facade, play with high volumes, installation of a sky light, and introduction of new structure are appropriate to the design project.

Although the Tate Modern is commendable in its sensitive approach to minimal impact on the historical fabric, the absence of apparent change to the building's exterior does not communicate the drastic change in the building's occupation.

The only visible transformation is apparent in the new skylight and through exterior signage. The design approach to the 2011 POPUP, will balance the act of new construction and conservation of the historical fabric such that the transformation in occupation would be visible through the built form.

The use of skylights and the treatment of atrium spaces (Illus 4.11) are noteworthy and will inform the design project in the consideration of material choice, volume and circulation.



Illus 4.10 Tate Modern (Perrin, 2002)

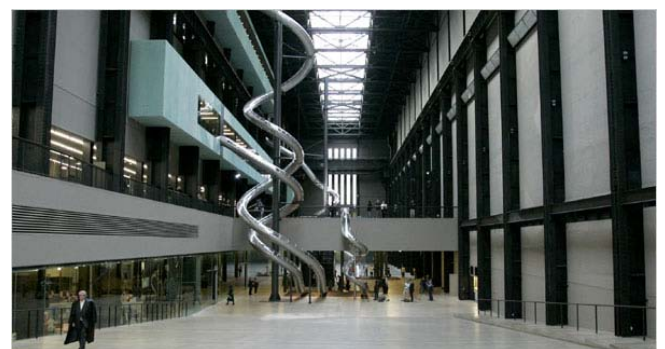

Illus 4.11 Tate Modern Volume, Skylight and Atrium (Smith, 2004)

4.2.4 Jolie Toujours, Tokyo (2008) by Ryoko Ando and MS4D



Illus 4.12 Jolie Toujours (Takahashi, 2008: 5)

Jolie Toujours is a knick knock store for women in their twenties and thirties. Ryoko decided to utilise classical historical elements as the basis for the design aesthetic. She abstracted defining elements of furniture and products of the classic age by drafting their profiles and using these as flat surfaces in display and product design (Illus 4.12). All elements were constructed using laser cut medium density fibre board finished with high gloss acrylic white paint. (Takahasi, 2008: 59).

Although the store is visually pleasing and interesting, the choice of the classical age does not originate from any meaning or interpretation. It is contrived and thereby seems superficial; an aspect which the designer strove to avoid (Takashi, 2008: 59). The use of abstraction of historical elements from a particular age and their reinterpretation in a contemporary manner, through materials, colour, texture and patterns can provide a meaningful part of the product and furniture design process with regards to the 1909 CEO and its connection to 2011 POPUP.

4.3 CULTURAL PRODUCTION

4.3.1 Imagine life on the other side of the planet, Perth (2008), by March Studio in the Awesome Arts Festival

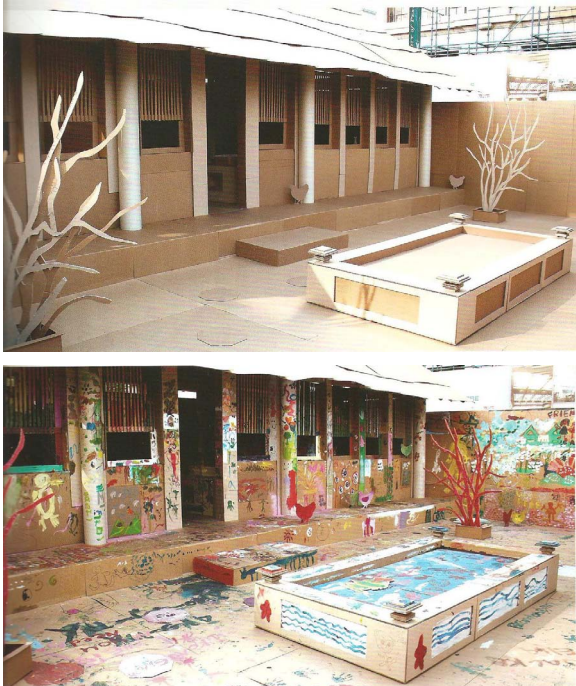

Illus 4.13 Imagine life on the other side of the planet (Kimme, 2008: 53)

This project involved the construction of a full scale Chinese courtyard house in cardboard by March Studio and then, the introduction of 750 children with art materials, given the instruction “Imagine life on the other side of the planet” (Kimme, 2008: 53). The result appears to be a vibrant and colourful space appropriated individually and collectively by the children (Illus 4.12, Illus 4.13).

This project provides a meaningful precedent for appropriation of the a-contextual by users. Since the 1909 CEO is of a past time, programme and user, its ideal state is not appropriate to its current user time and programme of 2011 POPUP. Through allowing personalisation of surfaces and spaces, the building may be appropriated by its current users who would be reflected in the space they inhabit. Murals, adjustable and modifiable work spaces, display surfaces and changing exhibitions can lend to this sense of appropriation.

4.3.2 Kasa Digitalia, Milan (2008), by Karim Rashid

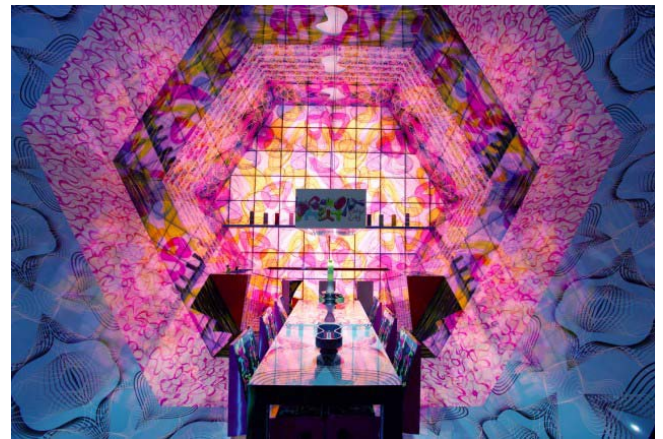

Illus 4.14 Kasa Digitalia (De Wild2, 2008: 65)

The company, Abet Laminati required a design of a concept house stand to advertise their new plastic laminate (De Wild2, 2008: 65). Karim Rashid designed hexagonal shaped spaces adorned with strips of patterns, creating a space reminiscent of a kaleidoscope (De Wild2, 2008: 65) (Illus 4.14).

The patterns chosen for the space, although decorative and vibrant, were chosen at random and are therefore devoid of contextual meaning to the concept house and its users. According to Rashid, pattern is an opportunity for decoration which provides the potential for customisation and expression (De Wild2, 2008: 65).

Pattern in the 1909 CEO is recognised in the chequered tile floors. These tiles are to be preserved as an intrinsic quality of the building’s historic character. Pattern use for appropriation can provide an interesting design element in the treatment of surfaces and 3 dimensional objects. Patterns to be utilised should, however, originate from a point of meaning and significance to the built fabric and its current users. Potential inspiration for pattern includes textiles, the railway line, crafting techniques and materials and historical wallpapers.

4.4 COMMUNITY

4.4.1 Barking Skills Centre, London (due 2012) by Rick Mather Architects

Barking Skills Centre (Illus 4.15, Illus 4.16) is an educational facility for 14 to 19 year olds with training programmes in hospitality, hair and beauty, construction and information technology (Rick Mather Architects, 2009).

This training centre is unique in that it sees itself as a college type facility which operates during flexible hours and offers an environment which is more conducive to the working world when compared to schools (Rick Mather Architects, 2009).

The Barking Methodist Church is alongside the skills centre (Illus 4.17) and the educational and religious typologies share meeting rooms, a square and community functions (Rick Mather Architects, 2009). The centre is also partially accessible to the public for events, seminars and lectures (Rick Mather Architects, 2009).

Although the Barking Skills Centre is an exemplary precedent of an educational facility, its user group is not thoroughly explored or expressed in the design process. 14 to 19 year old children are of schooling age, and the replacement of school with a skills centre in the lives of these users requires responsibility towards life skills training, counselling and support structures.

Although the user profile differs between Barking skills centre and POPUP, both user groups are of a background that requires life guidance and direction. In the case of POPUP, these are provided by POPUP counsellors and the treatment of these spaces is crucial, considering the role of life skills on the user.

The potential for religious facilities and public facilities to share spaces with the educational is worth investigation, especially since POPUP is a charitable organisation with many other interests (health care, child care and donation). The provision of a shared and overlapped space that addresses the users of the clinic, crèche and skills centre can be a meaningful exploration.



Illus 4.15 Barking Skills Centre and square (Rick Mather Architects, 2009)

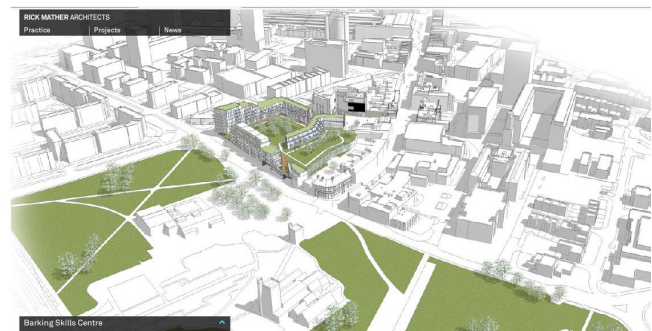

Illus 4.16 Barking Skills Centre and context (Rick Mather Architects, 2009)



Illus 4.17 Barking Skills Centre and the Barking Methodist Church (Rick Mather Architects, 2009)

4.5 CONCLUSION

This chapter has served to introduce various precedent and case studies pertinent to the design project. These were investigated to varying degrees, with relevance to their impact on the design process. The use of colour, light and pattern are to be utilised as design elements and the process of appropriation through customising is another significant outcome for cultural production. The study of the Barking skills centre has highlighted the role of 2011 POPUP as an educational facility, providing clarity for the design approach. The variety of heritage studies has provided a number of possibilities with regards to the architecture, interior design and product design processes.



Design Development

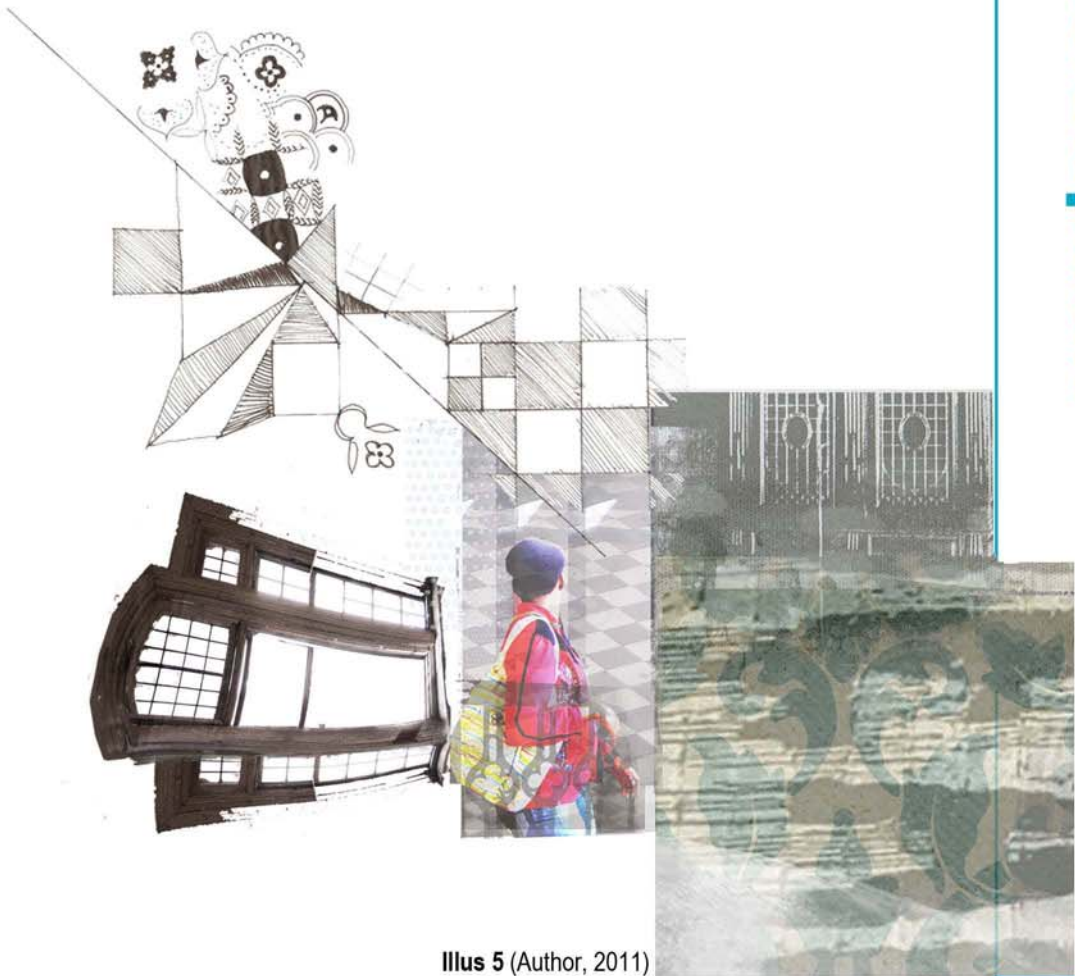

Illus 5 (Author, 2011)

5.1 INTRODUCTION

The design generation and development process will be outlined in this chapter. The steam punk movement, as the major design informant will be introduced and outcomes from its principles will be identified. The design concept resulting will be defined and illustrated in the form of mood boards and images of physical models as a form of design exploration and possibilities. Design, programmatic and conceptual development will be documented through visual and written explanation. Critique and outcomes of the process will be mentioned. Lastly, a final design draft will be presented.

5.2 STEAM PUNK

Steam punk is a movement of the 1980's and 1990's which strove to reinterpret the Victorian steam age nostalgically with a science fiction and fantasy twist which saw the machine achieving the impossible. The illustration below strives to explain this combination of historical with the technological science fiction and fantasy.

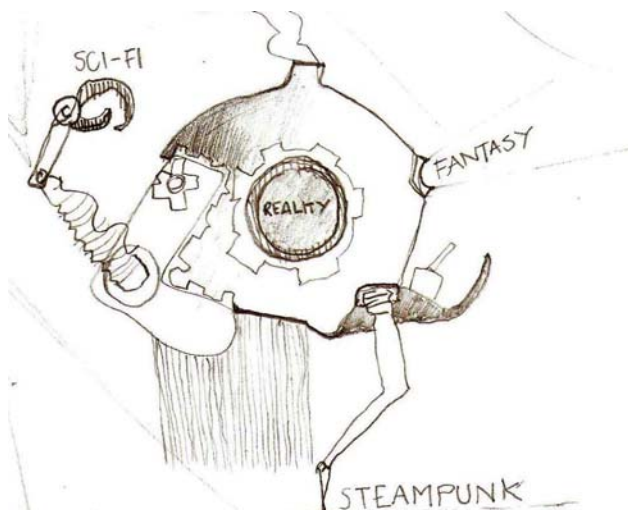

Illus 5.1 Steam punk (Author, 2011)

The movement is technologically oriented, with particular focus on the fantasy of what technology may be capable of (Illus 5.1). Steam punk is prevalent in art, design, literature, music, architecture, fashion and film.

Examples are illustrated alongside (Illus 5.2, Illus 5.3, Illus 5.4).

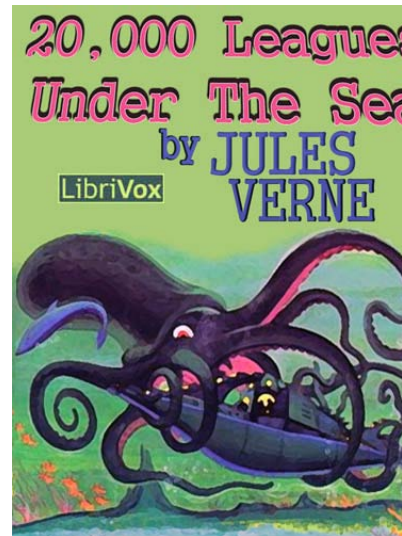

Illus 5.2 Jules Verne's "20 000 Leagues under the sea" (1869) is a classic literary work which influenced the steam punk movement (Willis, 2009)



Illus 5.3 Hayao Miyazaki's "Laputa Castle in the Sky" (1986) is a Japanese anime film which falls within steam punk genre (Canth, 2011)



Illus 5.4 Jean Pierre Jeunet's "The city of the lost children" (1995) is stylised and contains steam punk elements (Hudler, 2010)

5.3 CONCEPT (APRIL 2011)

Steam punk is of relevance to the design project in that it accepts the truths of an historical age to an extent, and thereafter, imagines the impossible within the historical framework. The imagination of the impossible detaches the historical from its time and appropriates it to futuristic possibility, thereby freeing it to another time.

The first mood board (Illus 5.5) alongside demonstrates the immediate response to the steam punk movement as a possible design generator. Images utilised in a digital collage format involve the fashion, architecture, interior spaces and technological focus of the movement.

Although the mood board does accurately reflect the steam punk movement, its response to the 1909 CEO / 2011 POPUP is not adequately expressed. The theory of cultural production and the addressing of change in occupation, as outlined in the theory of alteration, are ignored in this process. The design direction is inconsiderate of its context, users and time. Spaces of this nature would be too removed from the point of reference of the users, which contradicts the theory of cultural production which strives for product relevance and specification to its users (Venkatesh & Meamber, 2006: 12).

From this, it is concluded that for the design to move in a direction true to its theoretical informants, the 1909 CEO and 2011 POPUP should be reflected as the major design informants in terms of users, times and programmes. However, the exploration into the steam punk movement is not without value, since ideas regarding the approach to the historical may be abstracted within relevance to the 1909 CEO / 2011 POPUP.

The design concept may be defined as the re-imagination and reinterpretation of the “historical ideal” (Scott, 2008: 108) through current cultural production.

The “historical ideal” is recognised as the ideal aspects of the building which have been established according to the stripping back method. In the 1909 CEO / 2011 POPUP, this is identified as the facades and interior staircase, tiles and balustrades as discussed in Chapter 2.

Current cultural production is regarded as the need to apply extreme relevance of the design product to its users. This is intended to be achieved through exposing products created by skills learners as design generators which serve to reflect the users in the interior design.

The second mood board (Illus 5.6), alongside is a development from the first, with increased consciousness of the historical and current users, time and programme.

It differs from the first in that it uses the products created in the building (craft, textiles, textures, fashion, mosaic, murals) as the opportunity for new elements. The building’s historical and current users are depicted. An historical photo of the building interior (boardroom) is shown. Its furniture and finishing can provide meaningful points of departure for the new furniture and product design, especially in terms of stripping back as a means to take the design back and then forward.

This mood board strives to address the concerns that steam punk may be too removed from the design project by reflecting site, programme and users which are current and historical.

Fold out Page:

Illus 5.5 (Above) Mood board 1, April 2011 (Author, 2011)

Illus 5.6 (Below) Mood board 2, May, 2011 (Author, 2011)



Illus 5.5 Mood board 1, April 2011 (Author, 2011)



Illus 5.6 Mood board 2, May 2011 (Author, 2011)

5.3.1 Design Draft 1

The first model (Illus 5.7) demonstrates the historical ideal of the building, its facade and internal staircase, as well as a design proposal within this shell. The intervention is inspired by the precedent study, the Santa Caterina Market in Barcelona, and its treatment to the historical by a single radical element which caused a design impact to the architectural form and interior space of the building.

Natural light, within the 1909 CEO, although seen as being treated generously and resulting in pleasant spaces in the building, is not treated intelligently, since it is merely represented by a row of fenestration along the four facades. Orientation, thermal comfort and programmatic compatibility with lighting type is not considered.

Through this reasoning, it was decided that the idea of light may become a major design element through atriums and light wells which illuminate the inner parts of the building through natural light during the day, and may be backlit through artificial lighting at night, creating a visual impact to the building exterior.

Critique

- The design concept of reinterpreting and re-imagining the historical “ideal” is not clear or visible.
- Cultural production is poorly reflected (model scale is a limit to product design ideas which can only be demonstrated through sketches).
- The spatial freedom is limited by the structural columns.

Conclusion

- Break the skin for increased space in mezzanine levels.
- Maximise the quality and potential of light in the building beyond atriums and light wells. Consider the facades.
- Be bolder with the interior design.
- Remove everything but the ideal, and redesign the building.
- Return to the concept for design guidance.



Illus 5.7 Model 1, May 2011 (Author, 2011)

5.3.2 Design Draft 2

The second model (Illus 5.8) progresses the design from the first in that it accepts the shortcomings of the initial design attempt and strives to attend to these. The concept is reconsidered first in this process and the light wells (also seen in Illus 5.11), as the major design element, is recognised as being a reinterpretation of the stairwell of the “historical ideal” staircase within the 1909 CEO. These new wells are similar to the historical in that they are seen as opportunities for natural light and circulation but differ in that they may become objects related to the user through signage, exhibition, seating, surfaces and storage spaces. This is clear in Illus 5.11.

Further modifications involve projecting beyond the facade of the building to create North facing mezzanine spaces which also have views across the railway line (Illus 5.9, Illus 5.10). This is seen as an extension to the reinterpretation of light in the building. Mezzanines reinterpret and challenge the high volumes of the 1909 POPUP through the introduction of intermediate levels (Illus 5.9).

Critique

- The second mood board and model do not respond to each other even though the concept is the same.
- There is a lack of programmatic knowledge which is evident in the design process.

Conclusion

- Reinterpreting the historical is more clear, since the “ideals” have been identified, but the passion of the mood board must be introduced to plan and section.
- Schedule of accommodation guidelines are required to determine the sizes of spaces which break out of the facade. A more detailed programmatic analysis is required to address this.
- The architectural language and the interior design language need to be considered.
- Precedent studies should be looked at for more guidance.

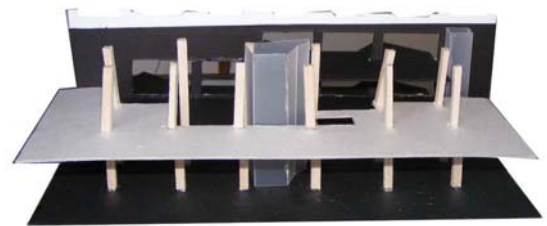

Illus 5.8 Model 2, May 2011 (Author, 2011)

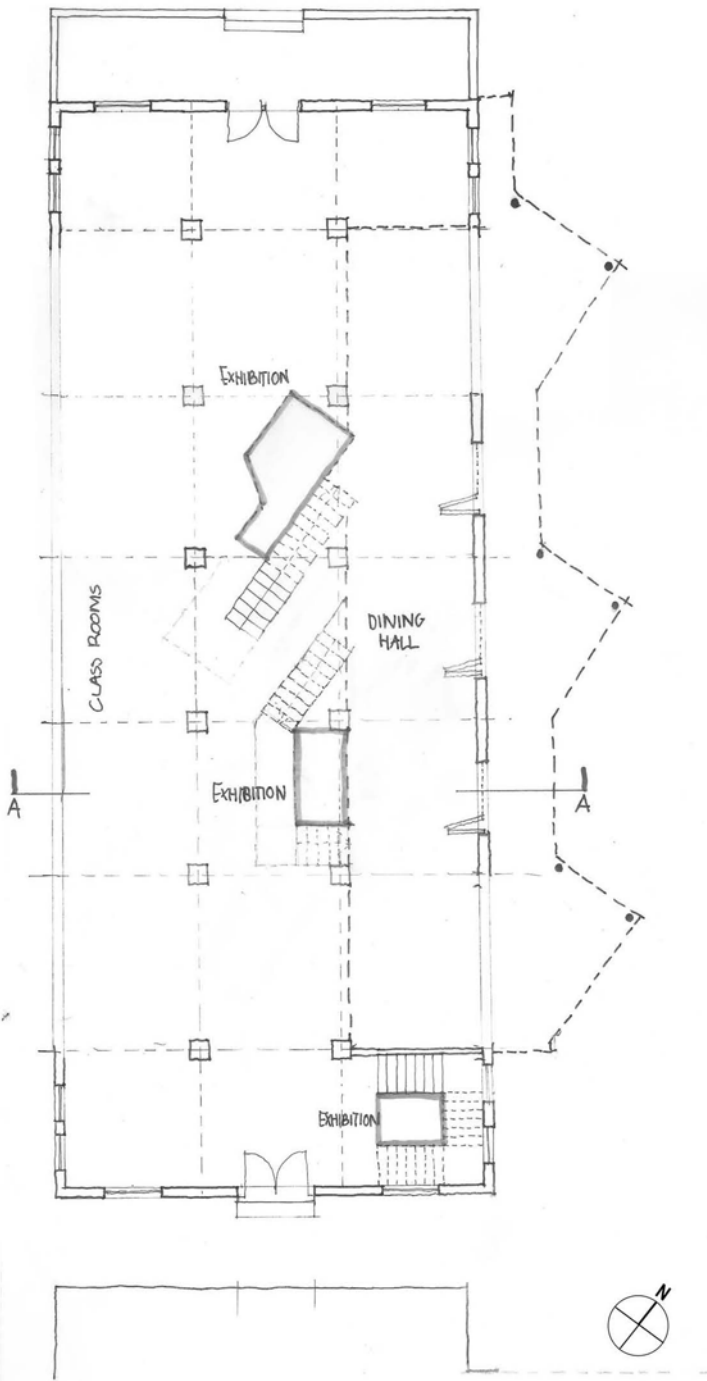

Ground Floor Plan

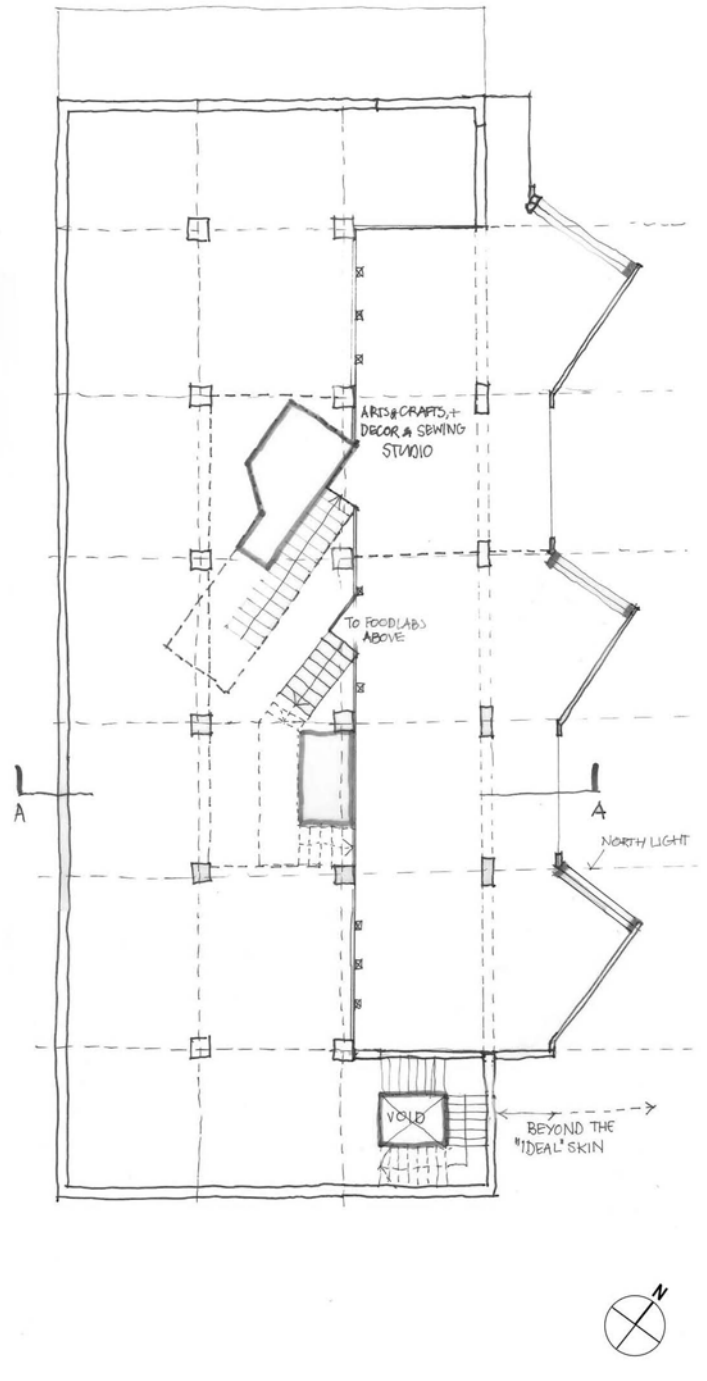

Mezzanine 1 Plan

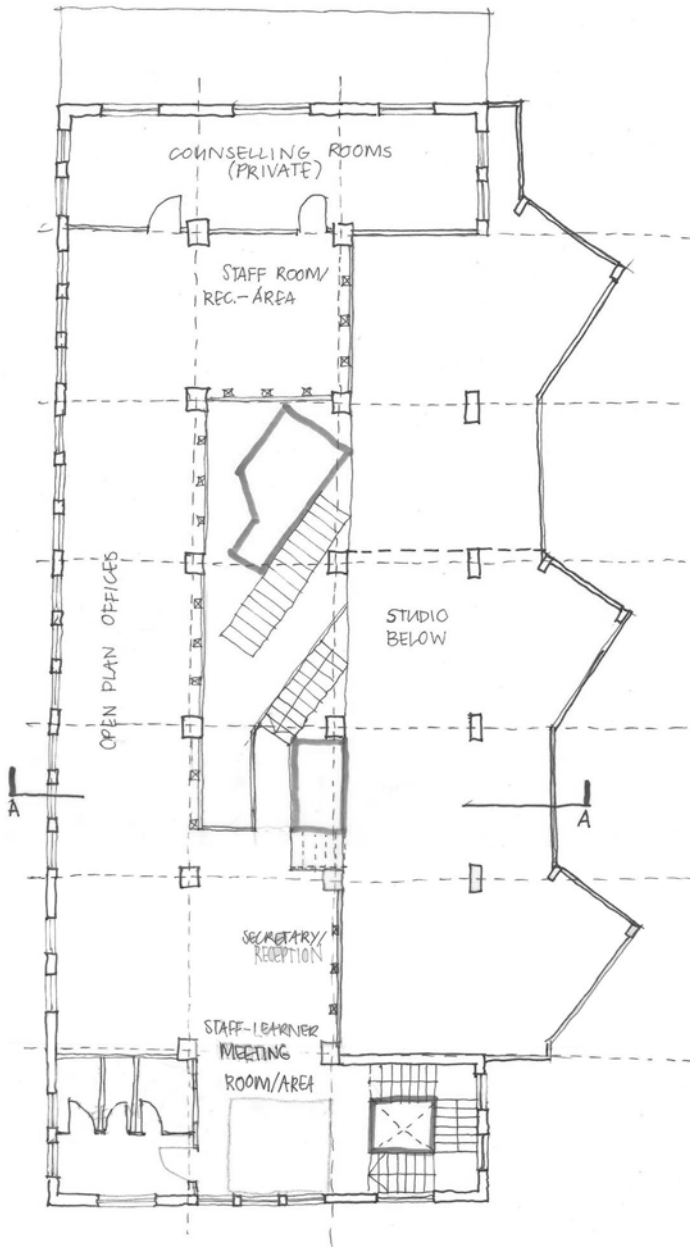

First Floor Plan

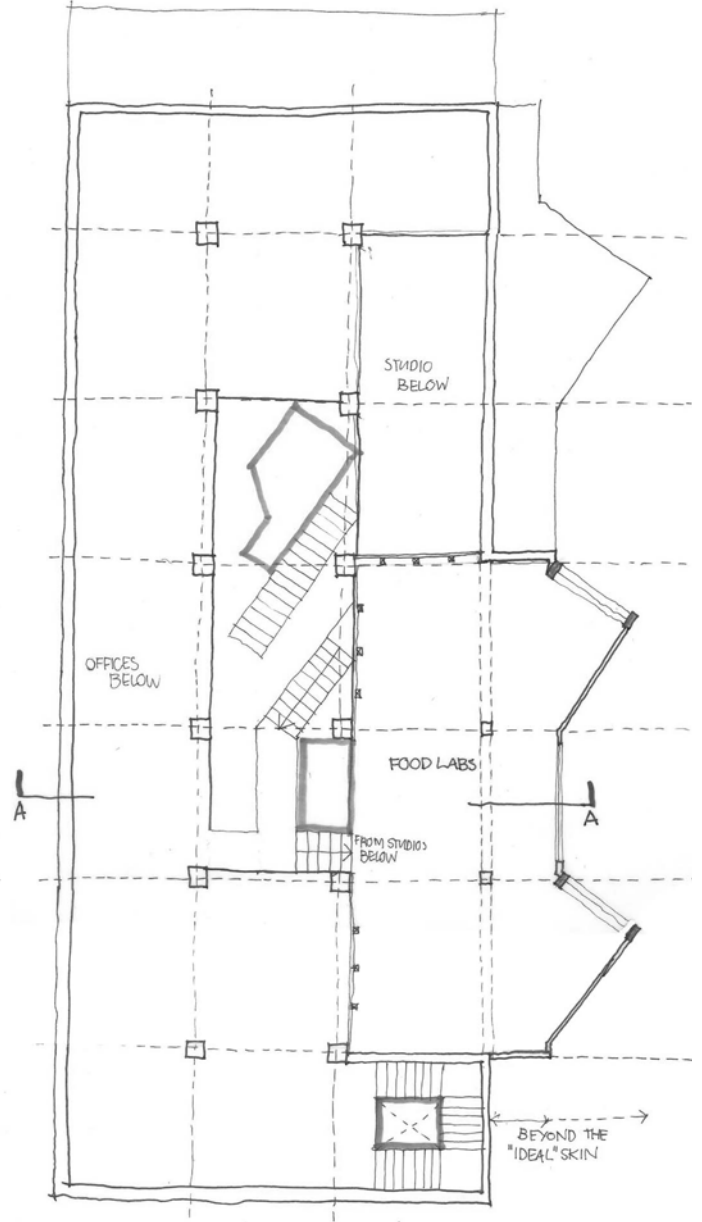

Mezzanine 2 Plan

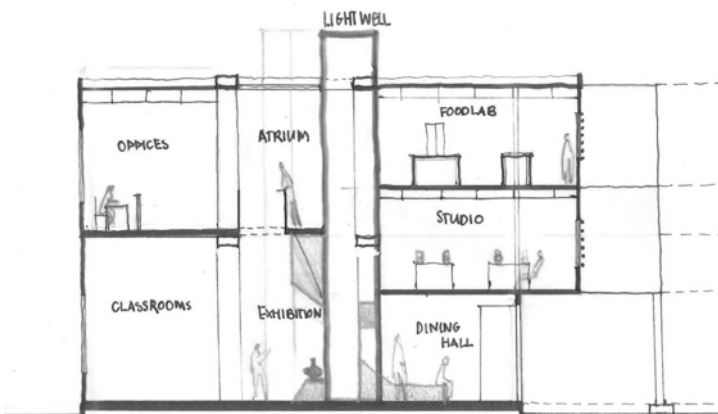

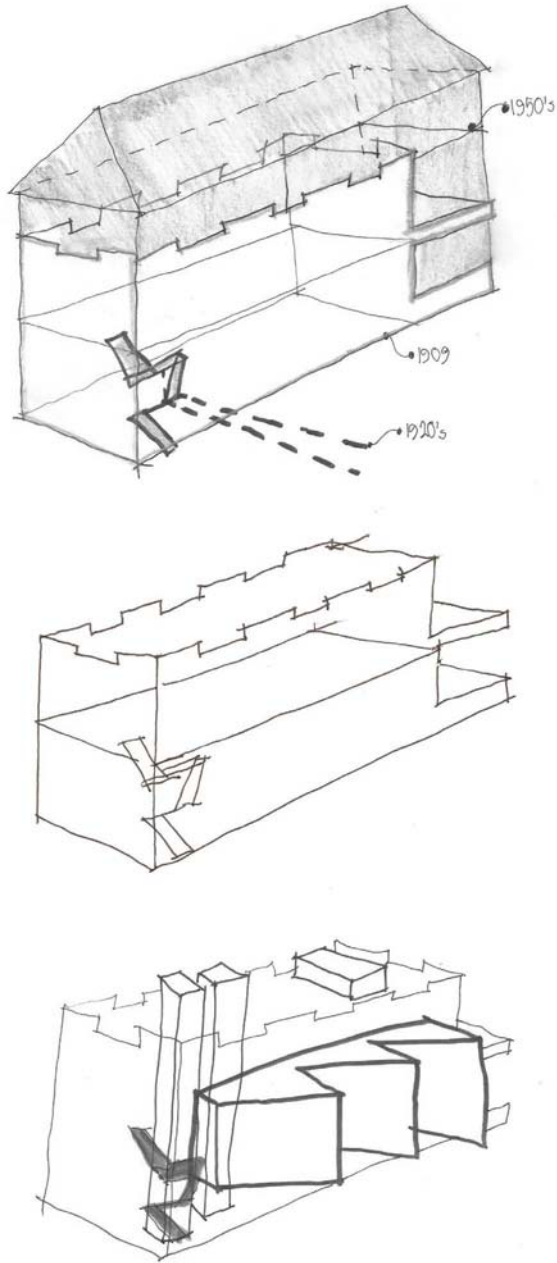

Illus 5.10 3 Dimensional Stripping Back Study, May 2011 (Author, 2011)

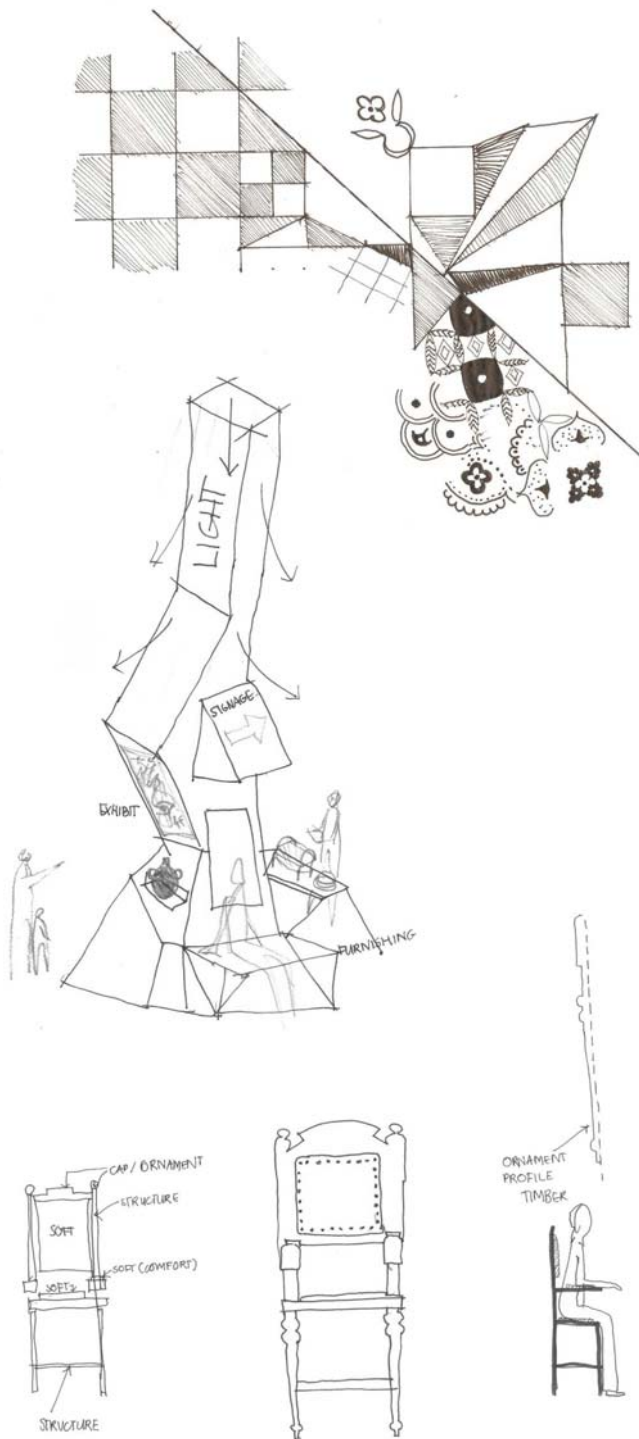

Illus 5.11 Re-imagining the Historical "Ideal", May 2011 (Author, 2011)

5.4 CONCEPT DEVELOPMENT (MAY 2011)

In order to overcome the difficulty of demonstrating the design ideas of the mood board in the plans, it was decided to map aspects of the mood board (Illus 5.6), model 2 (Illus 5,8) and the “historical ideal” as discussed in Chapter 2. These would be committed to plans which would then be layered, observed and outcomes identified.

Layer 1: Mood Plans (Illus 5.12)

This plan, conveys the patterns, textures and atmospheres portrayed in the mood board in locations which are mapped intuitively. The concept of cultural production is also used to imply activities in space, such as the red onion in food labs.

Layer 2: Diagrammatic Plans (Illus 5.13)

These drawings serve to diagrammatically simplify the intention of the model in plan. The main characteristics include the link of light wells as continuous vertical elements, new mezzanine levels within existing volumes, projecting beyond the skin and a possible new geometry.

Layer 3: “Historical Ideal” Plans (Illus 5.14)

In these plans, the existing and demolished historic characteristics are mapped. This includes the past relationship between the building function and railway line, floor finish (chequered terracotta tiles), the demolished bridge, the hierarchy of facade elements, staircase and natural light.

This exercise served to highlight the major characteristics of the building’s ideal, the design intention and the mood or atmosphere to be created. The major outcomes include:

- The use of pattern on vertical and horizontal planes as a design element, and reinterpretation of the existing chequered floor pattern,
- The exposure of cultural production occurring in spaces through exhibition and transparency,
- The manipulation of natural light,
- The use of an atrium and/or light wells as a reinterpretation of the continuous volume within the stairwell,

- Recreating the sense of entrance,
- Re-establishing the relationship with the railway line,
- The projection of the facade beyond the skin as a reinterpretation of the current image and static nature of the building, and
- The creation of intermediate mezzanine levels and new geometries which reinterpret existing volumes.

Apart from this exercise, architectural guidelines were briefly consulted in the third design draft in the form of ergonomics



G

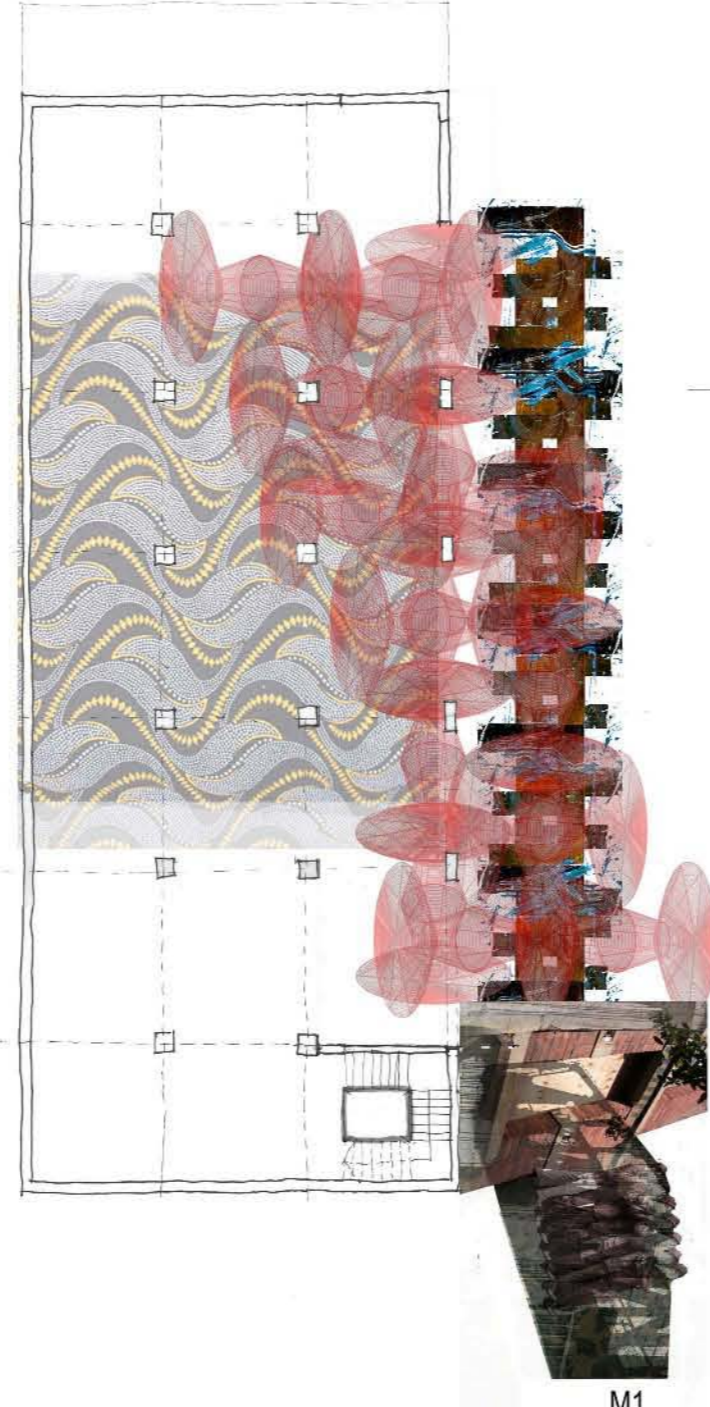

M1

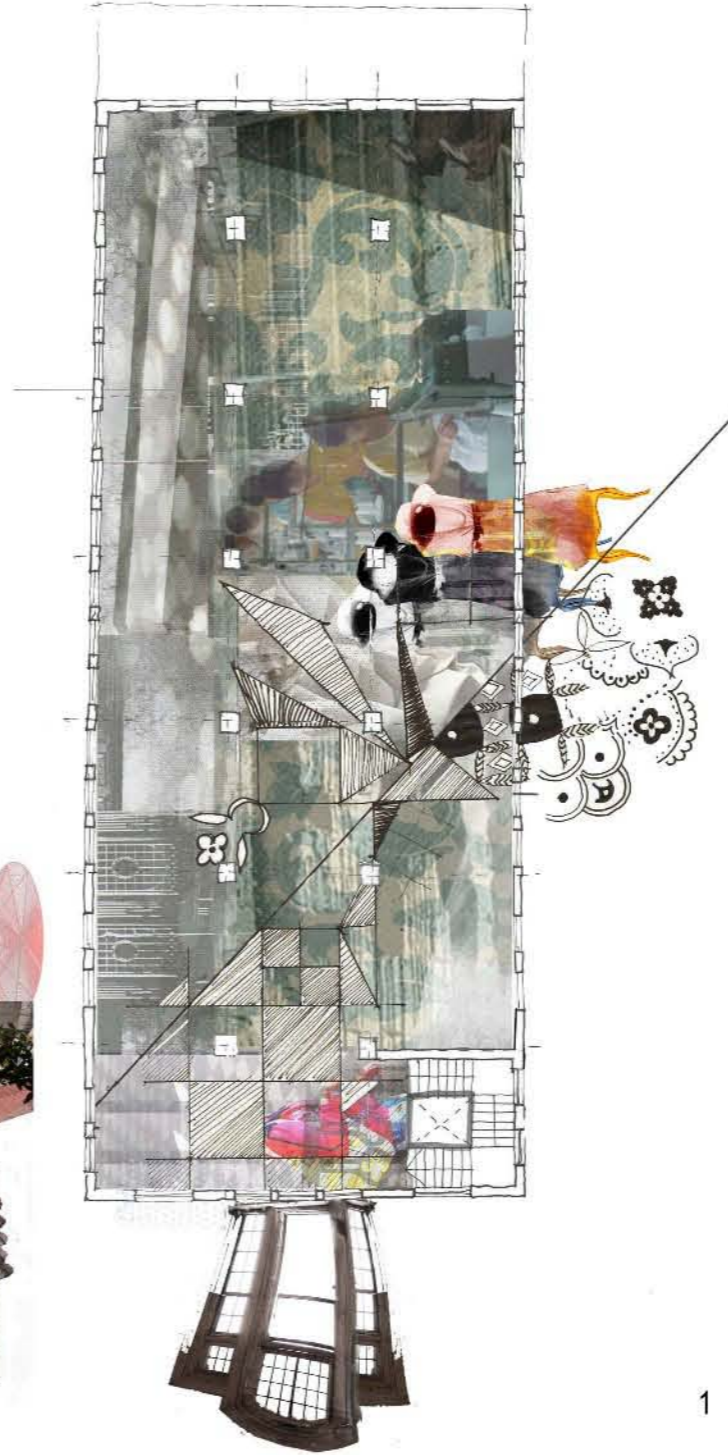

1

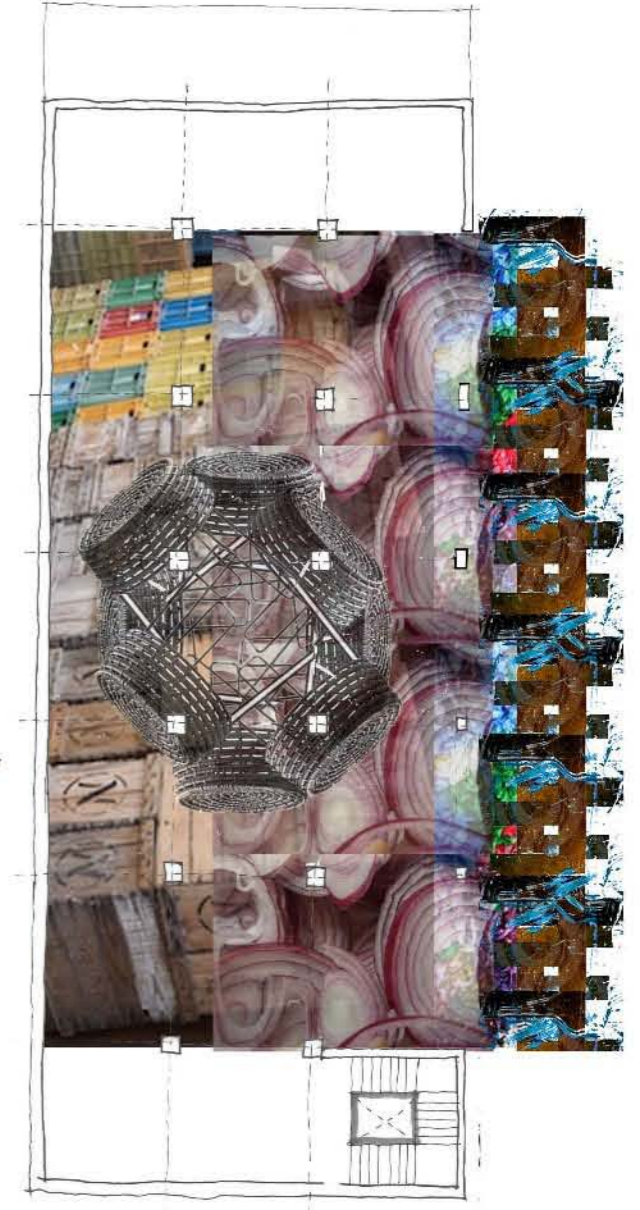

M2



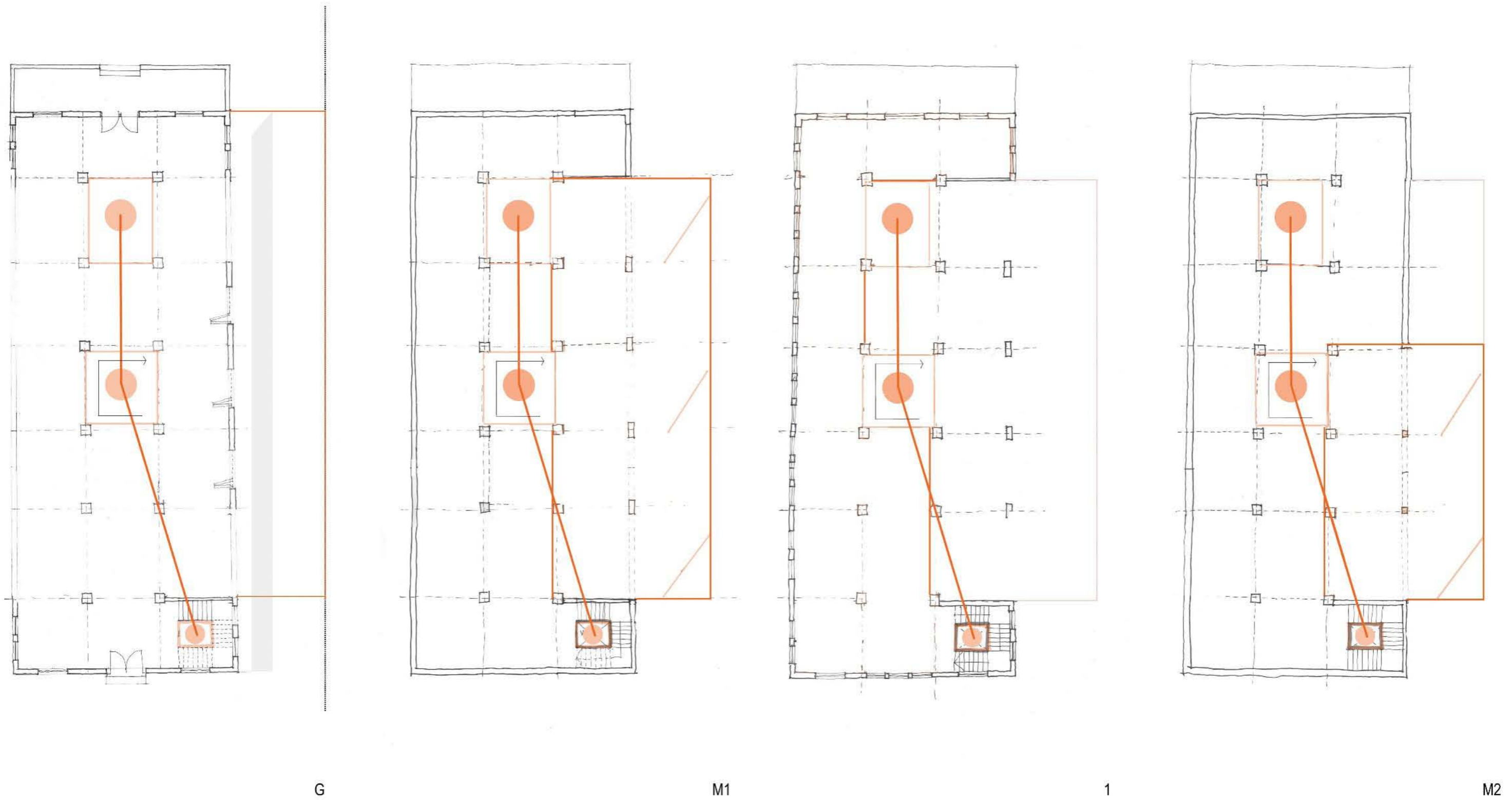

Illus 5.13 Diagrammatic Plans (May 2011) (Author, 2011)

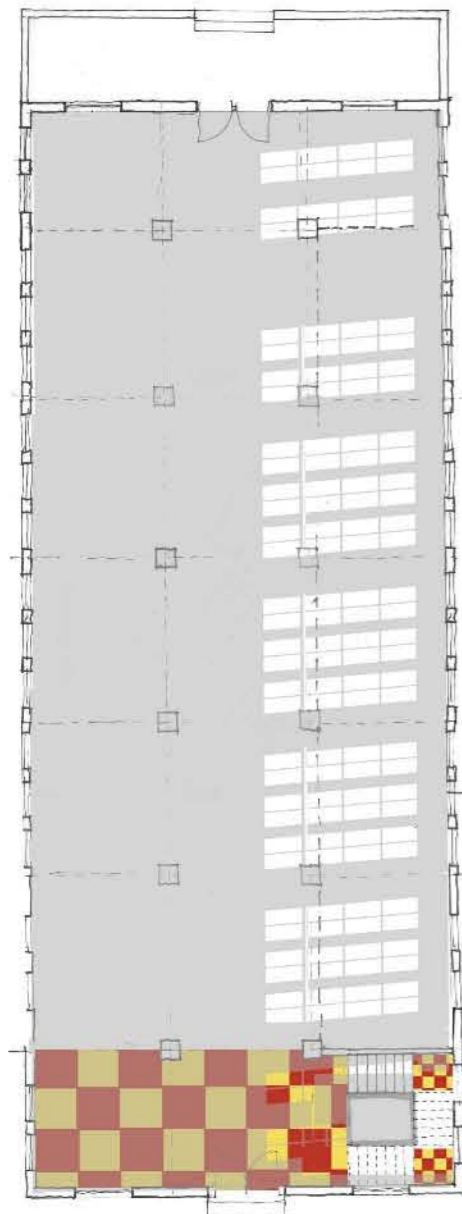

G

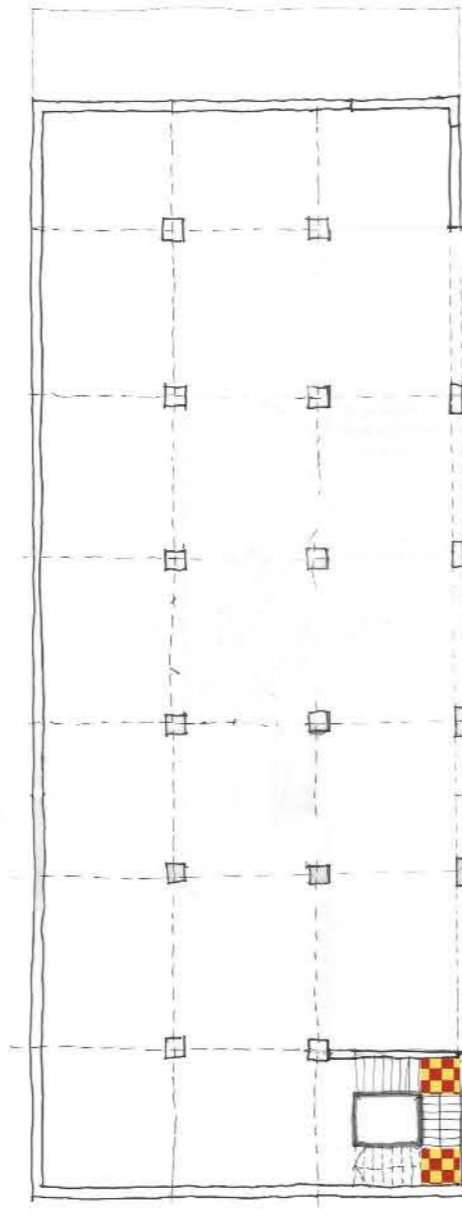

M1

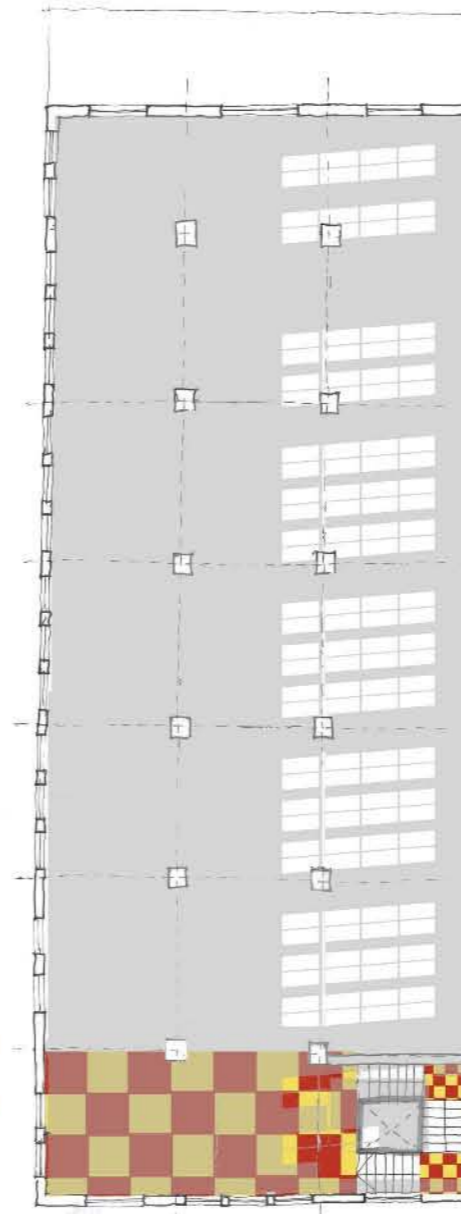

1

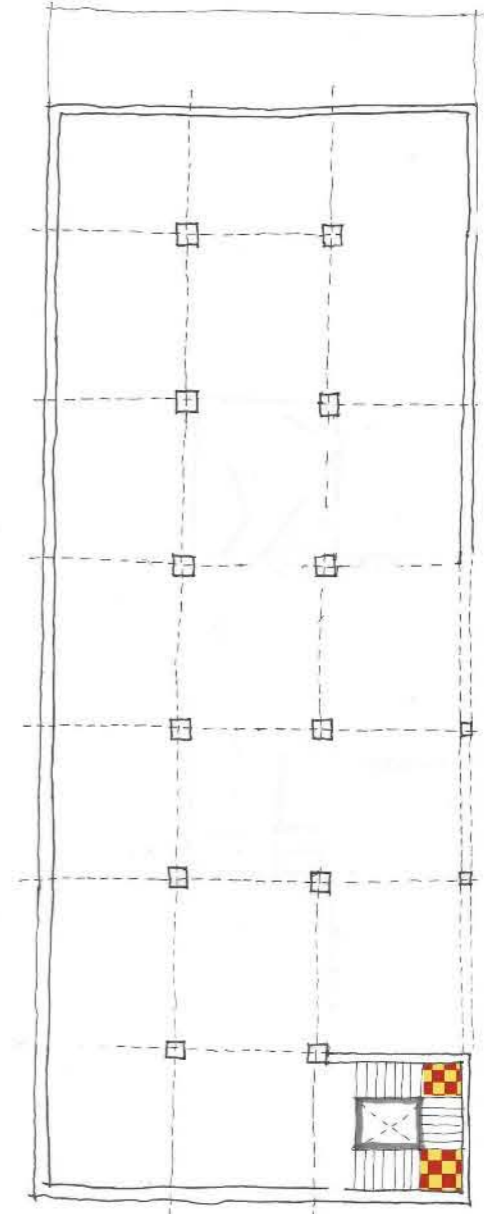

M2

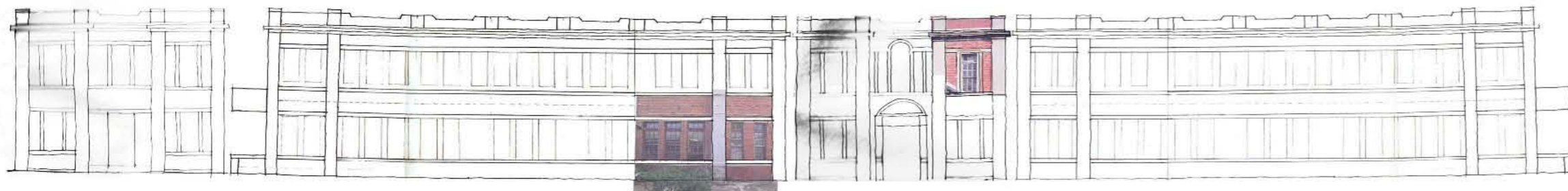

Illus 5.14 Historical Ideal Plans (May 2011) (Author, 2011)

5.5 DESIGN DEVELOPMENT (JUNE 2011)

Using the outcomes of exercises in 5.4, the following has been considered:

5.5.1 Entrance:

The entrance to the skills centre is currently uneventful, difficult to identify and congested. There is no central reception and inadequate signage to direct users and visitors. The sense of entrance is considered a significant aspect to the design in terms of arrival, direction and sense of place. This has been considered as follows:

- A new axis perpendicular to the skills centre is created to direct users to the building by means of a paved surface (Illus 5.15).
- The church and donations building alongside of the skills centre (East) is partially demolished and set back to allow a square entrance court between the two buildings creating a sense of arrival. This also highlights the hierarchy of activity on site, through size (Illus 5.16).
- Steel columns and glazing along the site edge frame views of the railway line, which creates a sense of place (Illus 5.17).
- A new reception area is proposed at the entrance of the church and donations building, for direction and assistance.
- Signage columns and banners are placed along the axis route and within the entrance court (Illus 5.18).

Critique:

- The entrance design is considered separately to the rest of the design and it should be one language.
- The entrance design is critical and further development should occur.

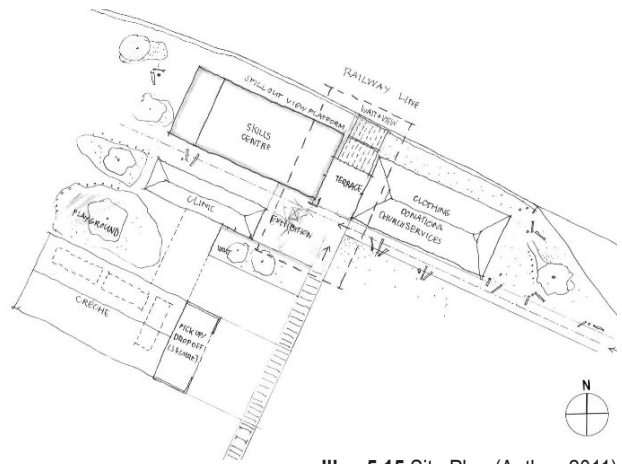

Illus 5.15 Site Plan (Author, 2011)

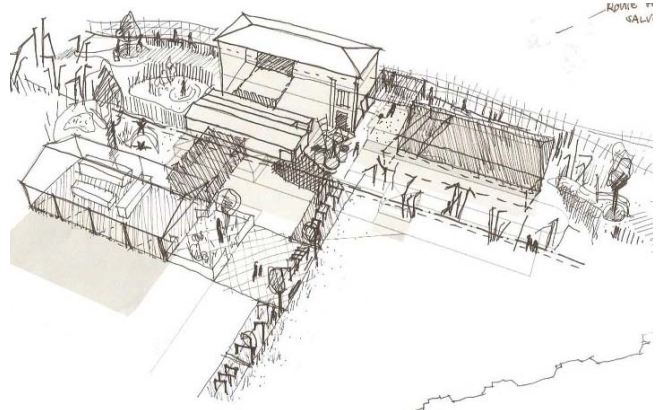

Illus 5.16 Aerial view of site (Author, 2011)

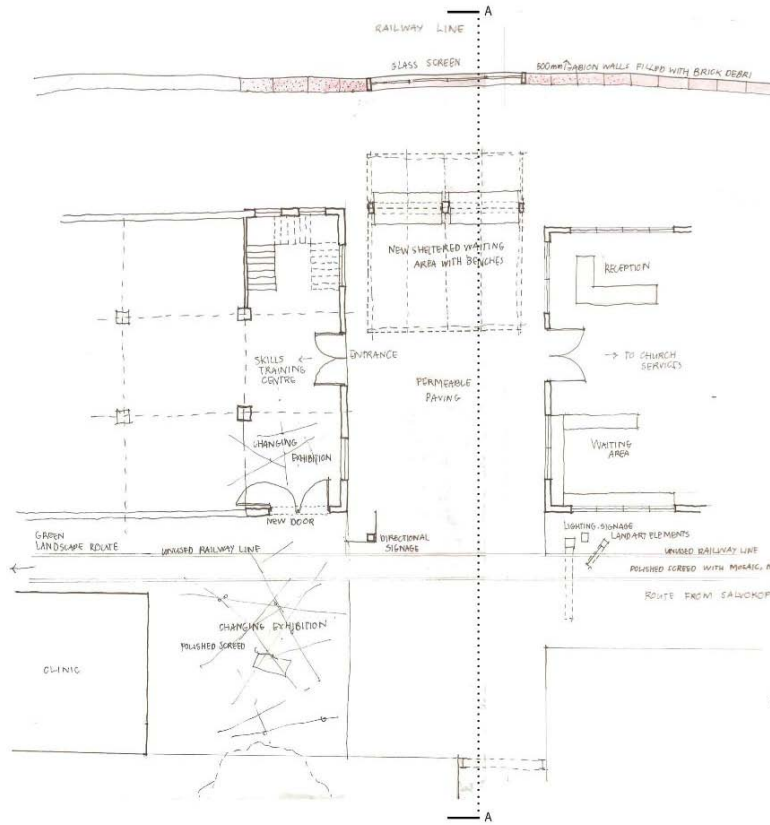

Illus 5.17 Plan through Entrance 1:200 (Author, 2011)



Illus 5.18 Section A through Entrance 1:200 (Author, 2011)

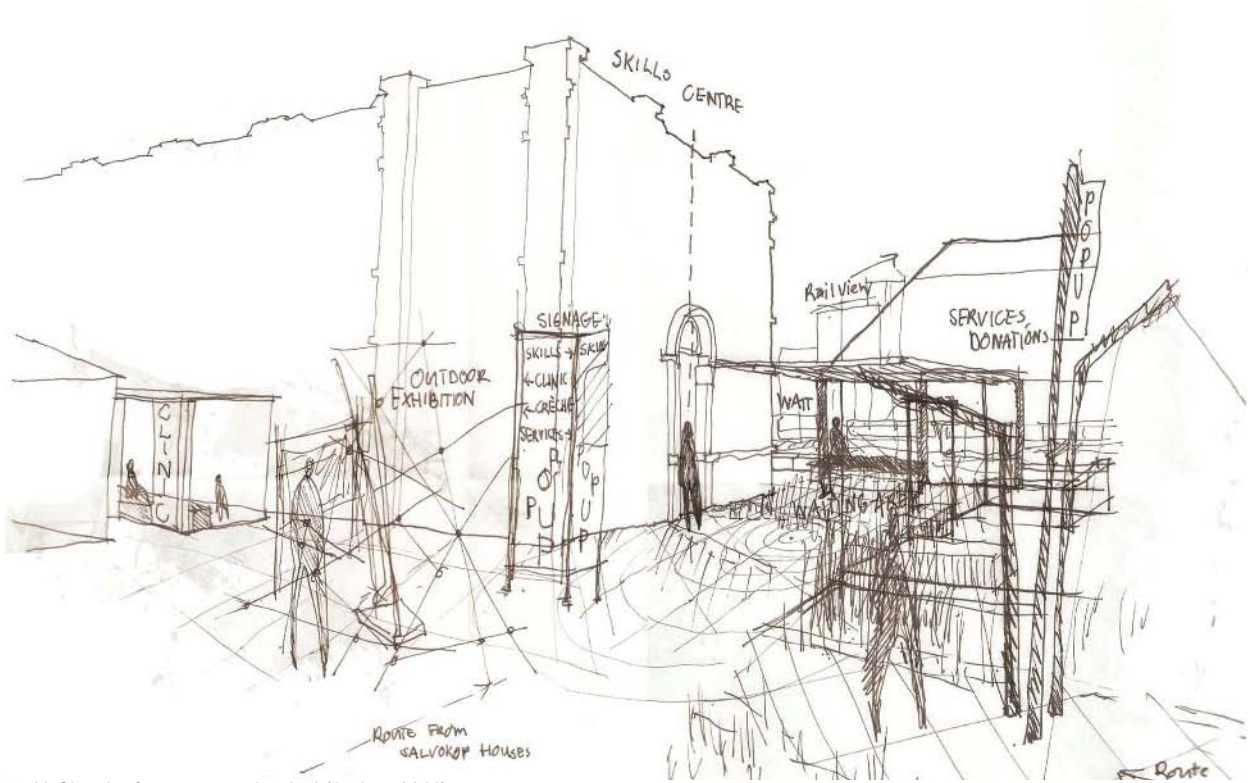

Illus 5.19 Sketch of entrance and arrival (Author, 2011)

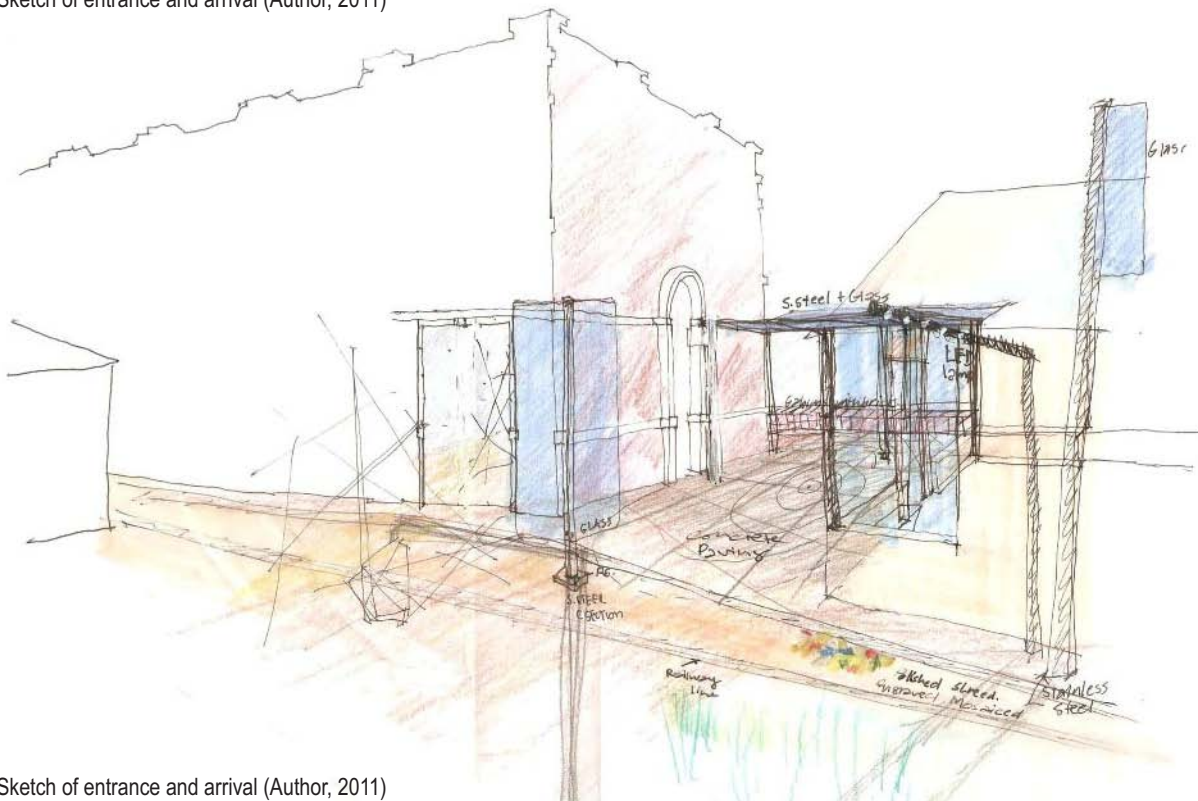

Illus 5.20 Sketch of entrance and arrival (Author, 2011)

5.5.2 Cultural Production (Illus 5.21 - Illus 5.26)

The sense of cultural production activity in the building is reflected through the spatial distribution of places of production (food LAB, Arts and Crafts and Decor and Garment Manufacturing) on the new mezzanine levels. These levels project beyond the existing facade in a new geometry which reflects transformation, exposes activity to the exterior (through glazing), allows the passage of North light into spaces, increases facade exposure to railway views and plays on the concept of “POPUP”, as a branding element visible across the railway line on the city side. This play of form indicates a change of the building’s occupation (user, time and programme) (Scott, 2008:1) and thereby appropriates new space to change through new image.

Critique:

- Spatial layout needs consideration
- Food LABS and wet service allocation is important.
- Food LABS on the North side of the building may be unsuitable due to heating. Media Centre Lounge would benefit more.
- Circulation is problematic.
- Inhabitation of space is not evident.
- Branding should be explored

5.5.3 Light (Illus 5.21 - Illus 5.26)

Two light wells spanning the volume of the entire building allow a visual connection between levels within the building interior and allows natural light to the central spaces of the building. This breaks the static nature of the building.

Critique:

- The light wells are communicated as solid and a lack of openings reduce connection between spaces. An atrium should be considered.
- The effects of layering light and shadow should also be explored.

5.5.4 General Comments (Illus 5.21 - Illus 5.26)

- The difference between old and new fabric needs to be reflected.
- The design could be more dynamic, reflecting the movement of the railway line.
- The outcomes of patterns, texture, exhibition and transparency can be exploited further.
- Technical requirements of specialised spaces, such as Food LABS should shape the design further.

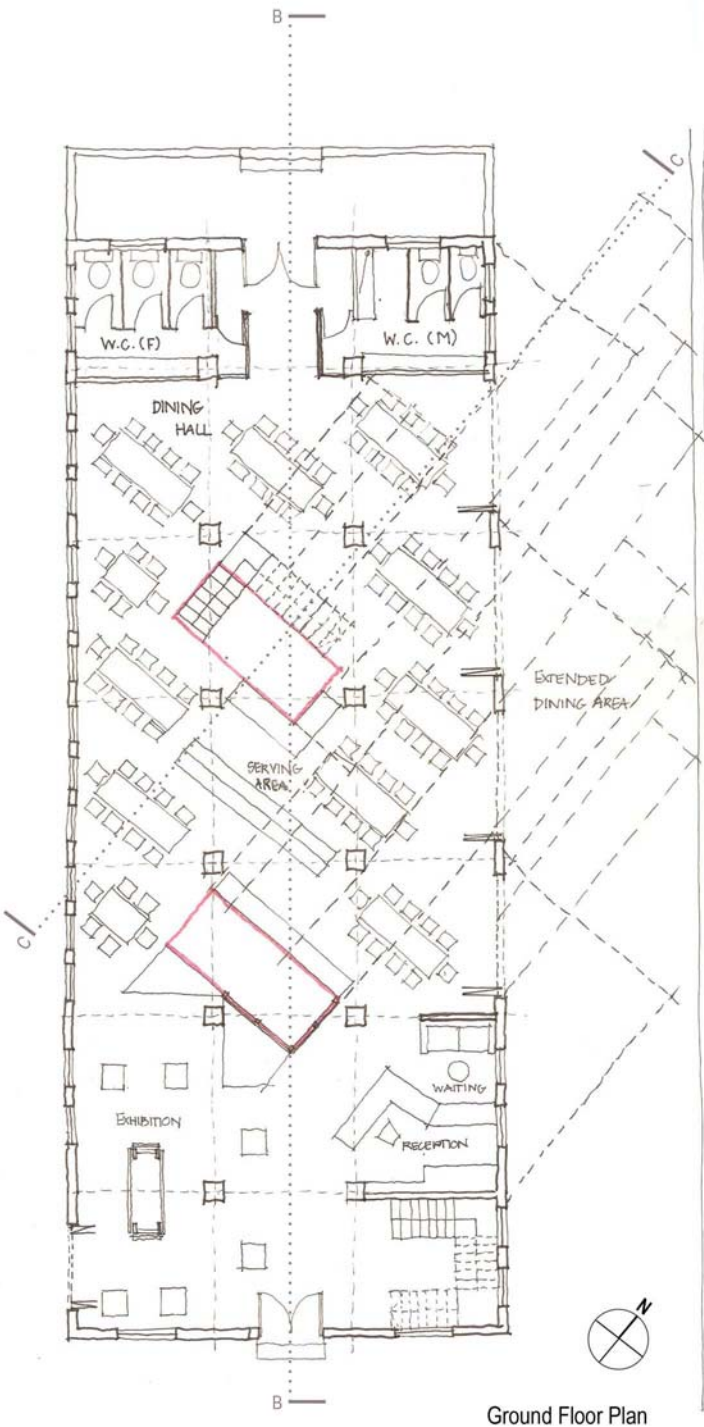

Ground Floor Plan

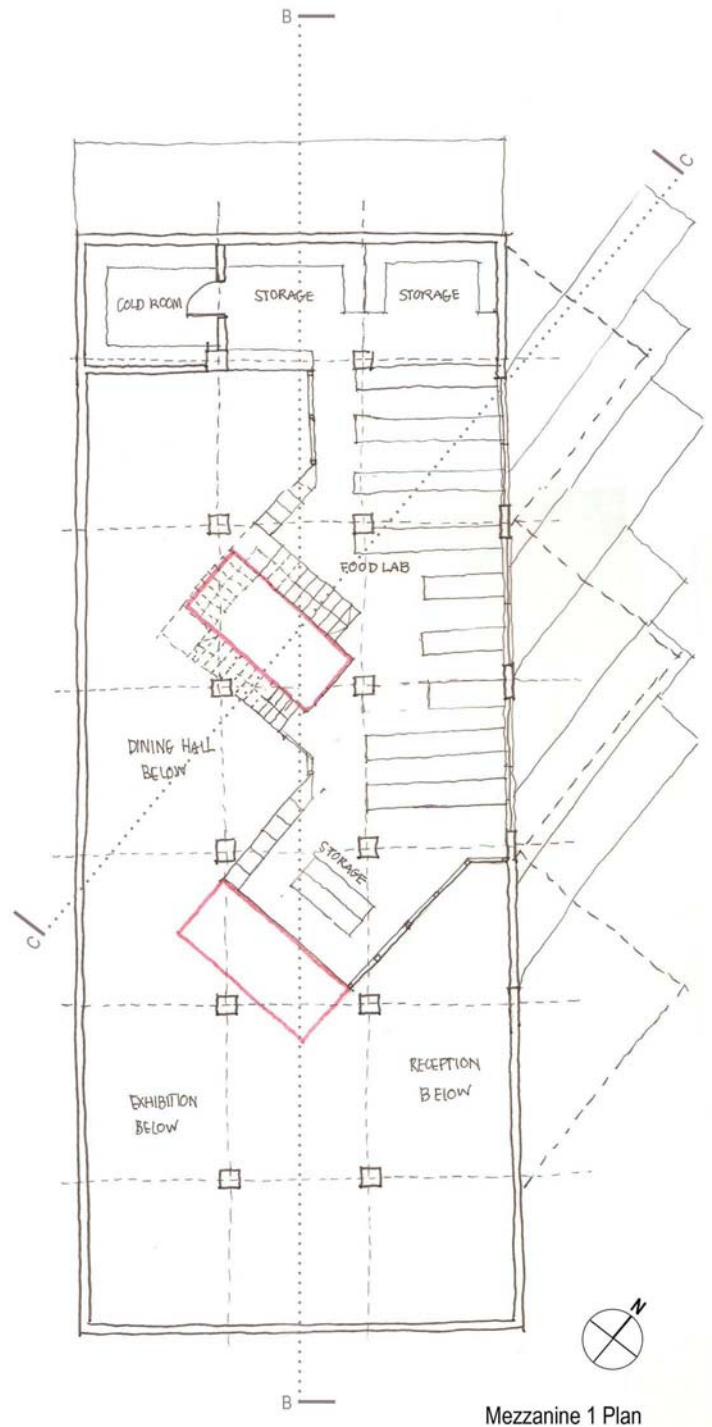

Mezzanine 1 Plan

Illus 5.21 Ground and Mezzanine 1 Floor Plans 1:200 (Author, 2011)

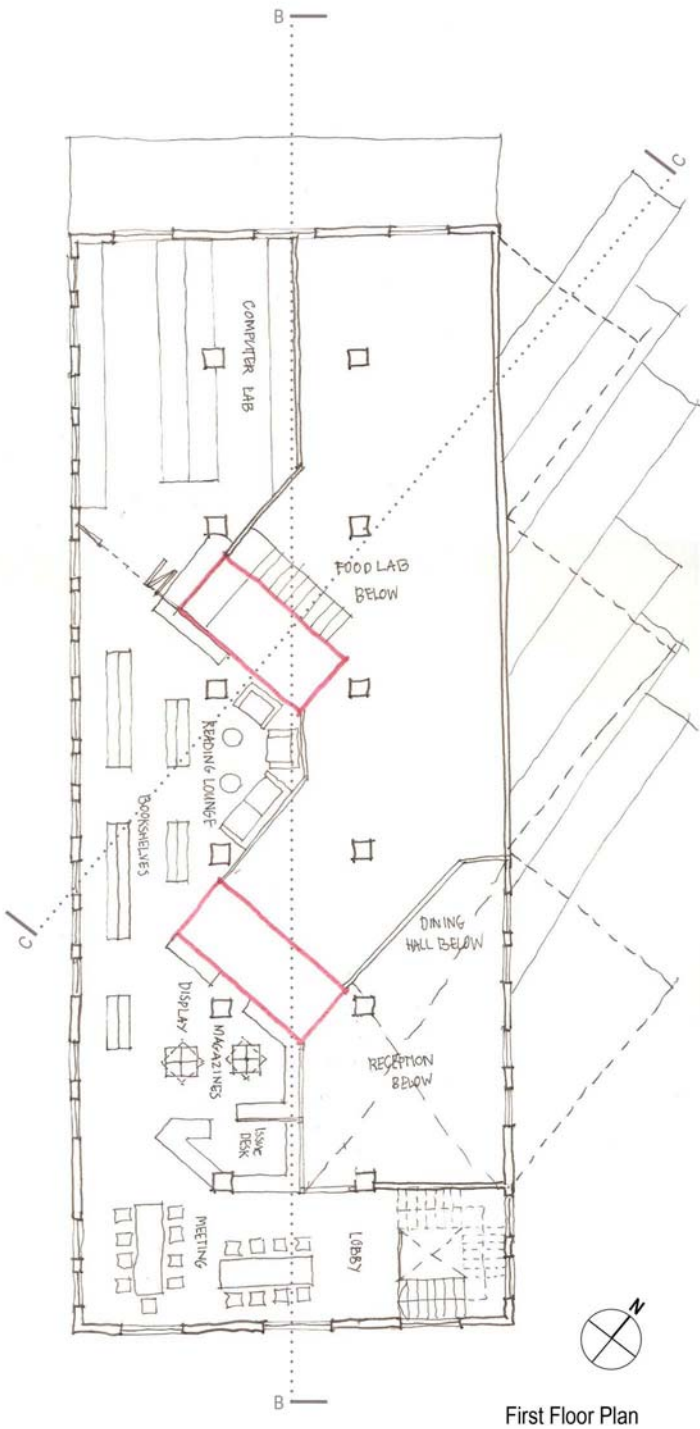

First Floor Plan

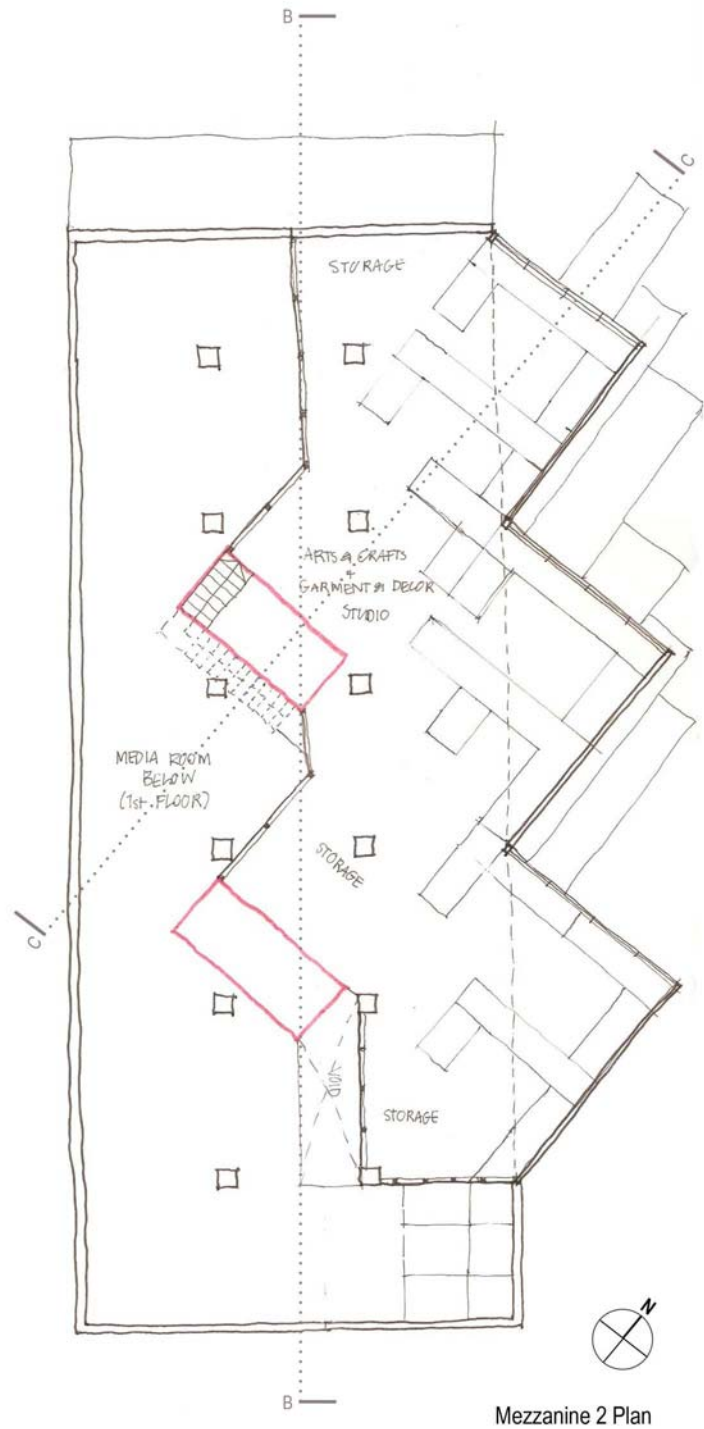

Mezzanine 2 Plan

Illus 5.22 First and Mezzanine 2 Floor Plans 1:200 (Author, 2011)



Second Floor Plan

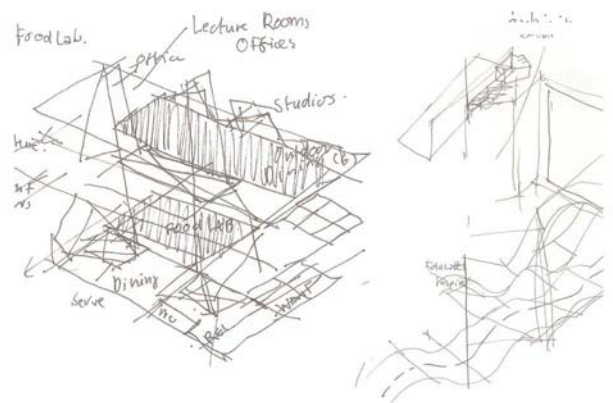
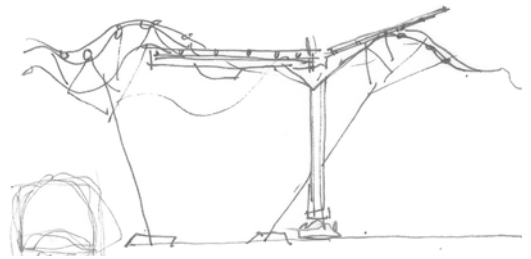
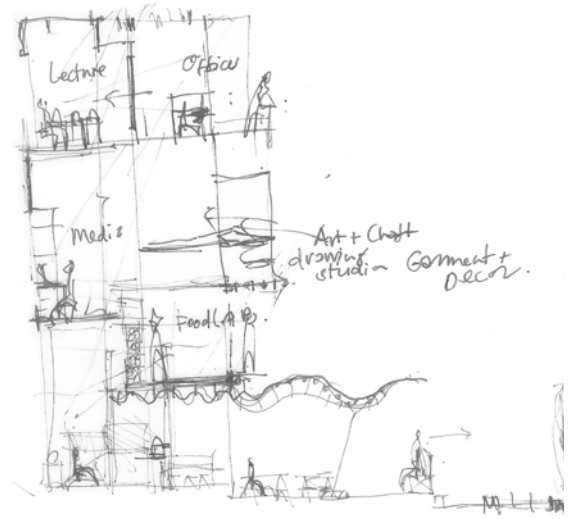

Illus 5.23 Second Floor Plan 1:200 (Author, 2011)

Illus 5.24 Process Sketches (Author, 2011)

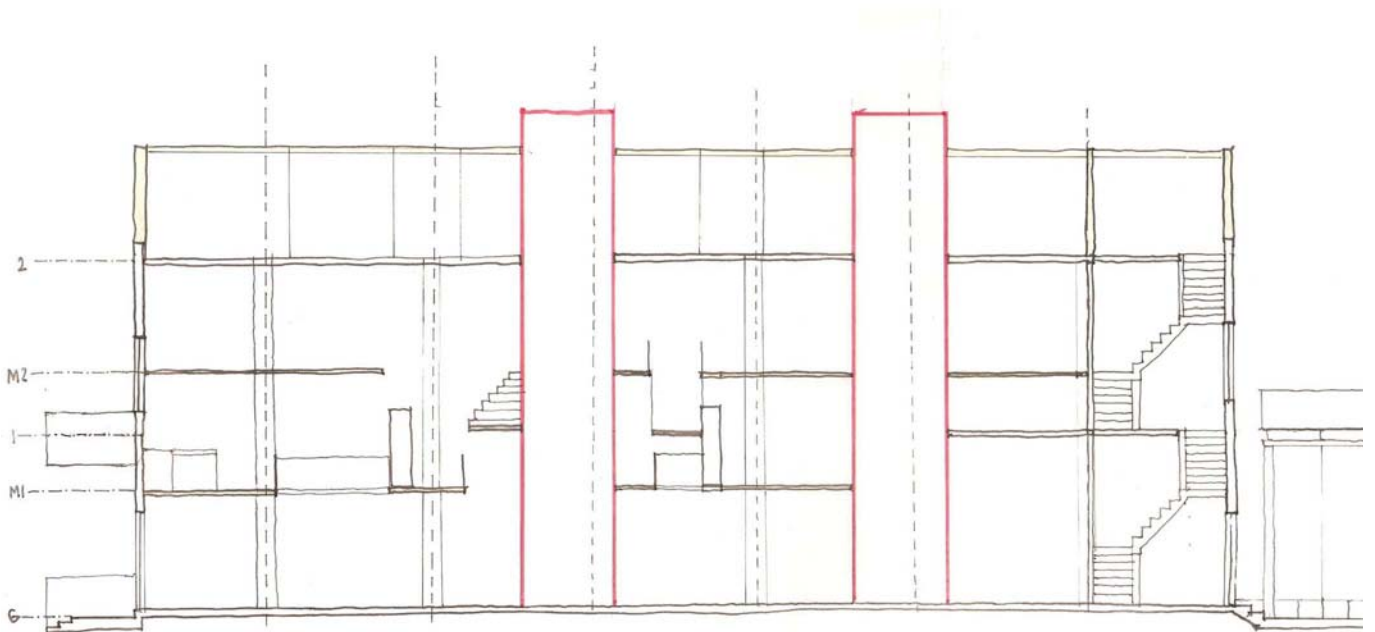

Illus 5.25 Section B 1:200 (Author, 2011)

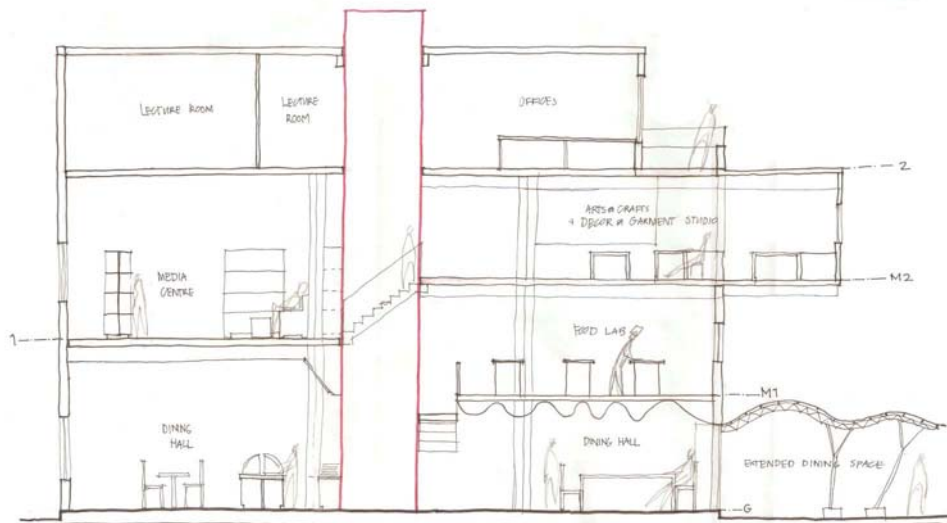

Illus 5.26 Section C 1:200 (Author, 2011)

5.6 ACCOMMODATION REQUIREMENTS (JULY 2011)

Due to the lack of technical knowledge driving the previous design draft, it was decided to document the spatial and technical requirements of certain spaces. For this, the building was divided into its respective functions, which were investigated through building standards, precedent investigations and ergonomics. The outcome of this exercise is as follows:

5.6.1 Dining Hall

The dining hall is a space used between 12h00 and 13h00 as an eating and food serving space for the 60 to 70 learners of the skills programmes. Food served includes light lunch meals, such as sandwiches, fruit, water and salads. Outside of these times, the space may be used for recreational purposes, such as social seating areas, break spaces or waiting areas between classes.

The dining hall was housed in the building alongside (East of) the skills centre, but will now be accommodated within the building since it caters for learners specifically.

- Lunch will be prepared in the Food LAB.
- Learners will bring their own sandwich containers and crockery with dedicated space for self service washing up and drying in the dining hall.
- The meals will be issued on a digital meal ticket system operated by an employee of POPUP.
- Certain areas of the dining hall may be enclosed out of dining hours as class rooms.
- Cleaning will occur daily between 13h00 and 13h30, after which classes (in enclosed dining spaces) may resume.

Tables of size 700 x 700 mm at 750 mm (Illus 5.27) height would be utilised as the modular size for tables throughout the building and increased incrementally where required. A table of this size would be suitable for 2 diners and two tables will be grouped for 4 seats. A space of 1500 mm is required from the end of one 4 seater table to the next where chairs are back to back (Illus 5.28).

Deliveries would occur along the back of the building (Portico Entrance) and transported to the floors above using the passenger lift.

5.6.2 Studios

The Garment and Decor manufacturing studio requires spaces for storage of fabric rolls, sewing equipment, cutting surfaces, meeting areas and work spaces. The Arts and Crafts Studio requires storage space, meeting areas and work surfaces. A sink will also be required for washing up.

5.6.3 Food LAB

Access to the food lab will be controlled on the ground floor through a glazed screen and door to the staircase. This door will be unlocked before class by a staff member of POPUP and locked once class is over.

All wet services will be allocated to the south of the building, including toilets, sinks, cold room and the washing trough.

Air supply to the food lab and cold room will be mechanically provided and extractors placed above each stove top for smoke and smell control.

The cold room requires technical consideration in that it is insulated, has a ramped entrance, epoxy floor an air curtain at the entrance and an insulated door with an automatic closer.

5.6.4 Lecture Rooms

Lecture rooms will be acoustically insulated. Seating will be provided in a bench and table unit system which allows 500 mm seating space per student.

A permanent work space will be placed in each room to accommodate the teacher. Each lecture room accommodates 35 students, including two wheelchair spaces in front.

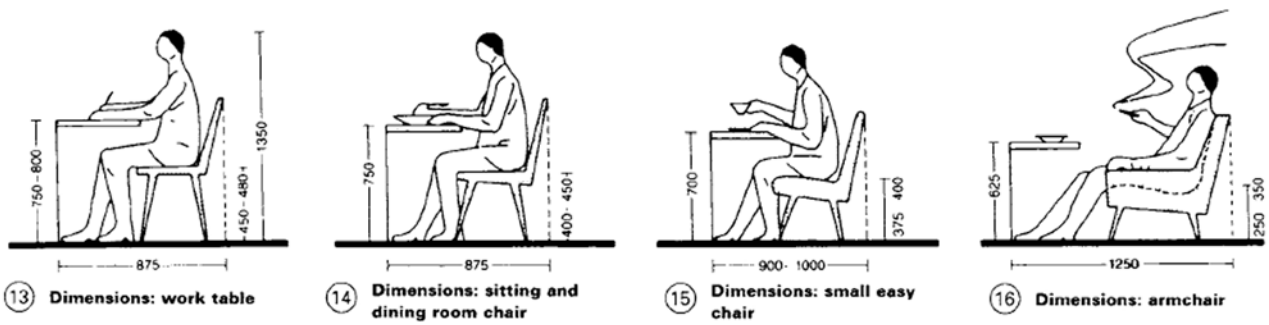

Illus 5.27 Ergonomic seating conditions (Neufert, 1999: 16)

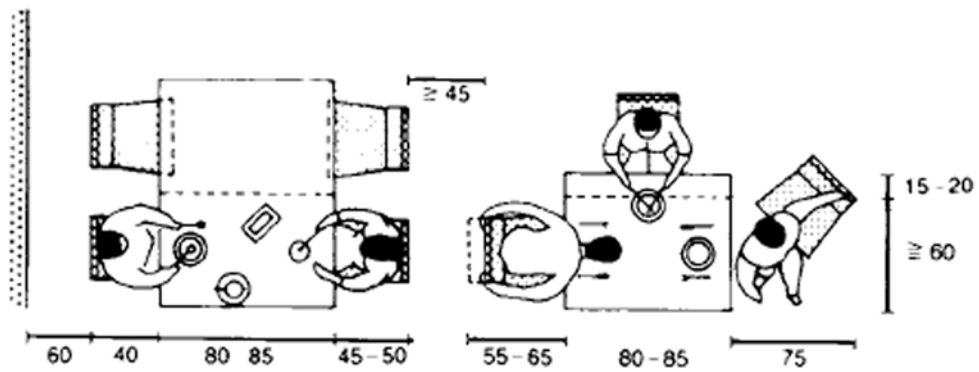

Illus 5.28 Dining Seating Conditions (Neufert, 1999: 455)

5.7 BRANDING (JULY 2011)

A refreshment of POPUP's existing branding and logo (Illus 5.29) strategy was deemed necessary as a change in the building and spaces would assist in establishing a new sense of appropriation to the space.

The approach to the logo design was seen conceptually as a reinterpretation of the existing POPUP logo, with the introduction of graphic elements which reflected the design intention too.

An analysis of the original logo revealed a sense of upliftment, aspiration and achievement, but was criticised for its formal and old-fashioned font, illegibility and busyness. It was decided that a less formal logo be developed, with the font also having a recognised graphic quality (as seen in Illus 5.30) that maybe adapted. The colour, orange, seen as a brand colour for POPUP is used in the new logo (Illus 5.31) and in the interior design.

Furthermore, the logo was adapted into various forms which reflect the values of POPUP (Illus 5.32). These variations still refer to the principal logo in font and size but differ according to each value's message.



Illus 5.29 POPUP logo (POPUP, S.A.)



Illus 5.30 MoMA branding (Iheartgum, 2009)

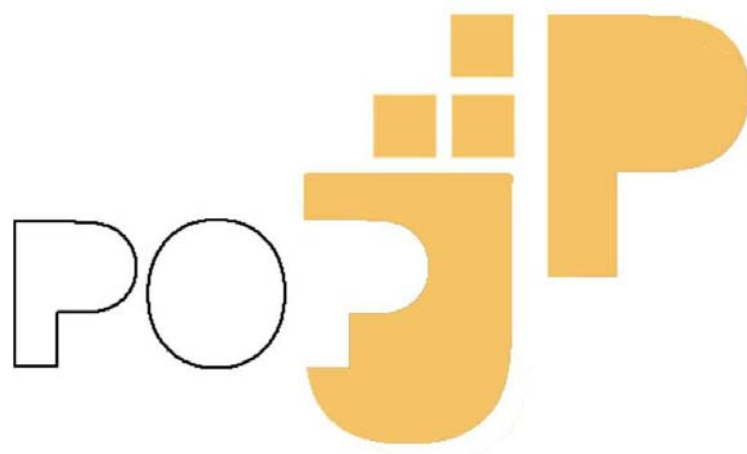

Illus 5.31 New POPUP logo (Author, 2011)

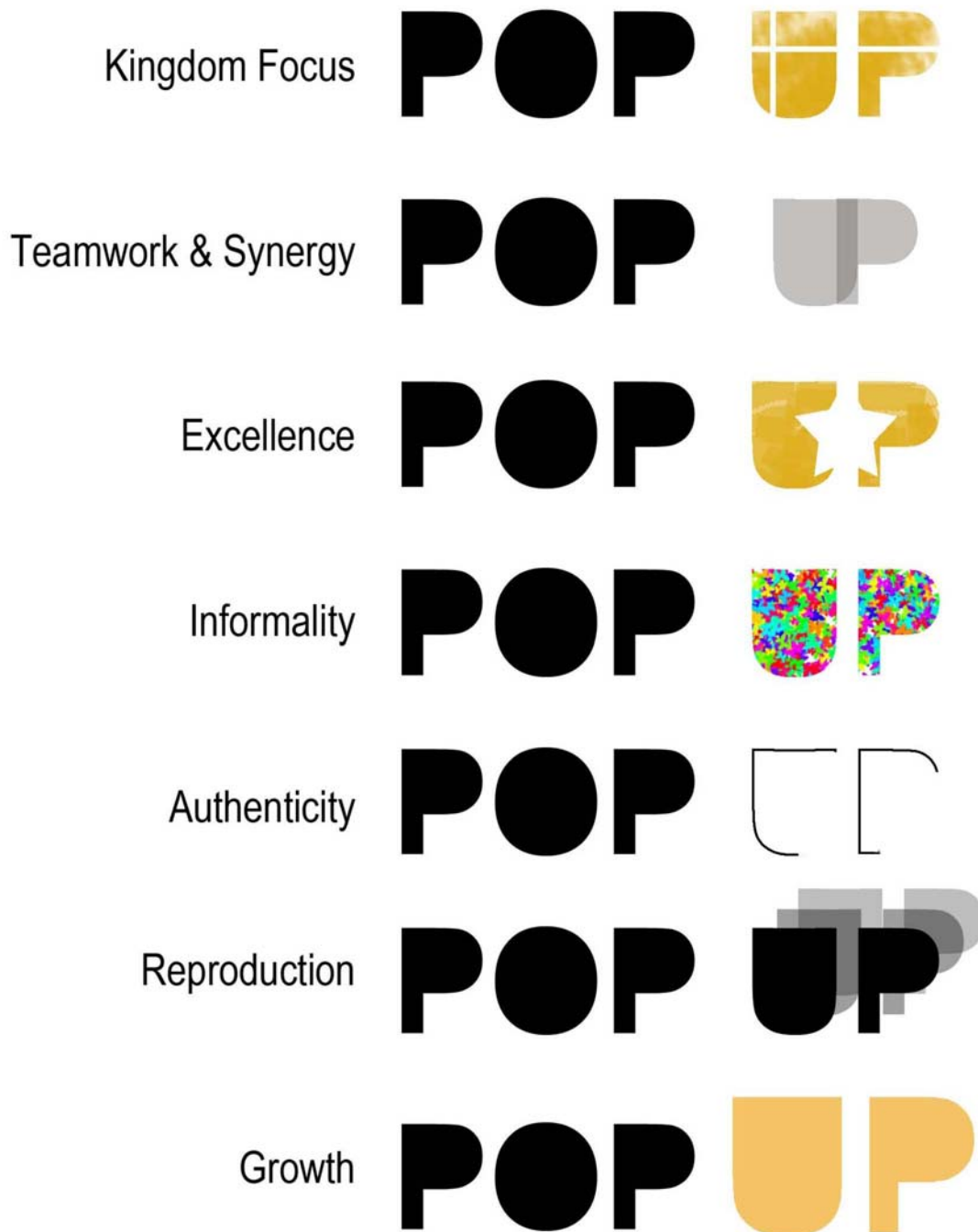

Illus 5.32 POPUP logo Variations (Author, 2011)

5.8 FINAL DESIGN (JULY - OCTOBER 2011)

The design concept of reinterpreting and re-imagining the “historical ideal” through current cultural production has been exploited through the design process from the major design characteristics to the product design. The mood board was used as a point of reference to inform design decisions in the treatment of space.

These characteristic design interventions include:

- the introduction of new mezzanine levels which reinterpret existing volumes and add new structure.
- the introduction of a multivolume atrium and skylight which allows natural light into spaces and visibility between and across spaces, revealing the activities to users.
- the finishing of surfaces which refer to the historical but are applied by learners of the relevant skills training in a creative manner through concrete, wallpaper and mosaic.
- the exposure of spatial activity through storage elements and furniture which exhibit food, art, craft, garments and decor.
- a re-established relationship with the railway line in its inclusion as a contributor to site atmosphere achieved through, a promenade, views and visibility.
- a new geometry which reinterprets the static, encompasses views, allows north light into spaces, plays on the word “POP - UP”, reflects transformation and is a visible branding element across the railway line from the city.

These characteristics are apparent in Illus 5.33 - Illus 5.40.

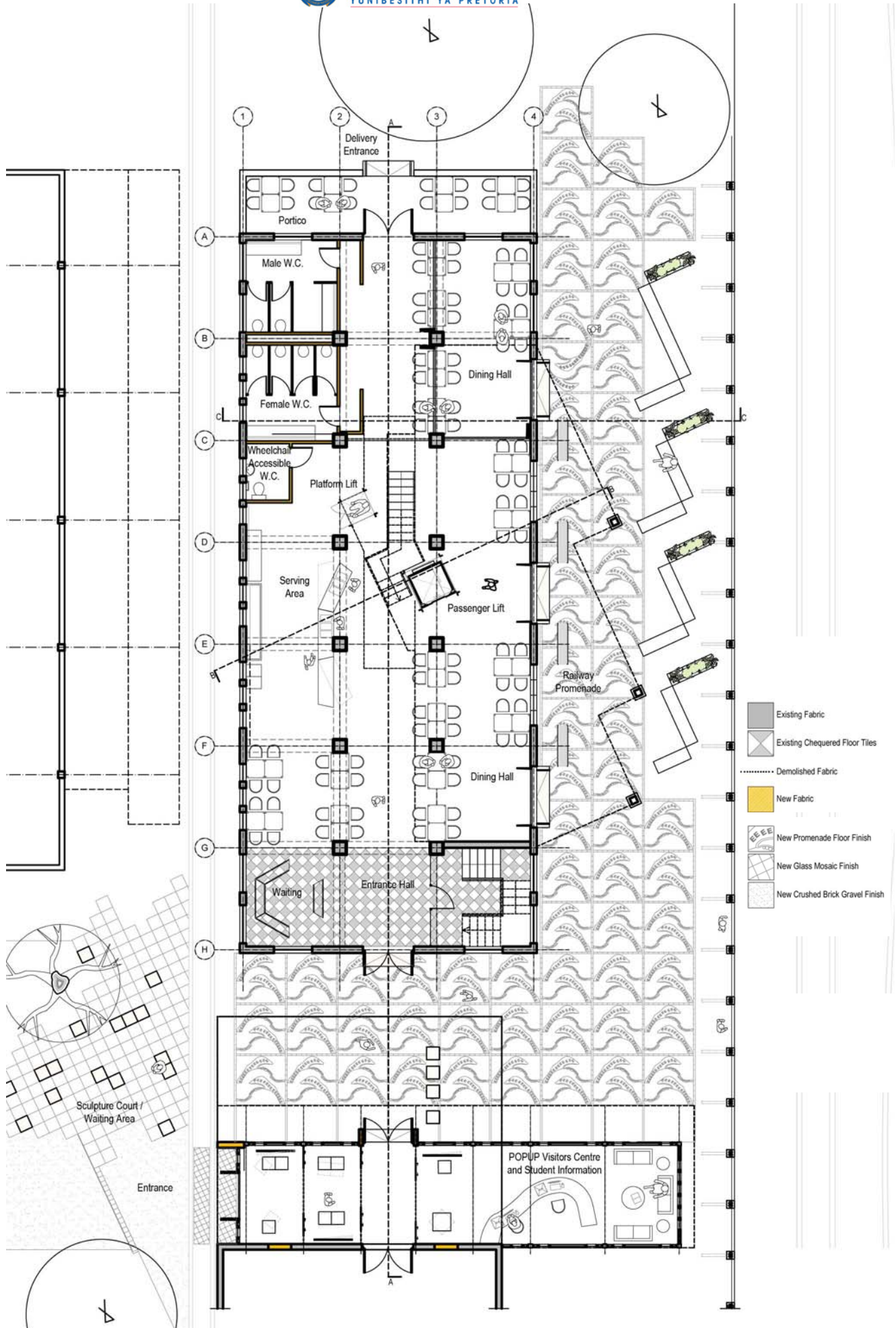

Illus 5.33 Ground Floor Plan (POPUP student information and visitors centre, Dining Hall)- 1:200 (Author, 2011)

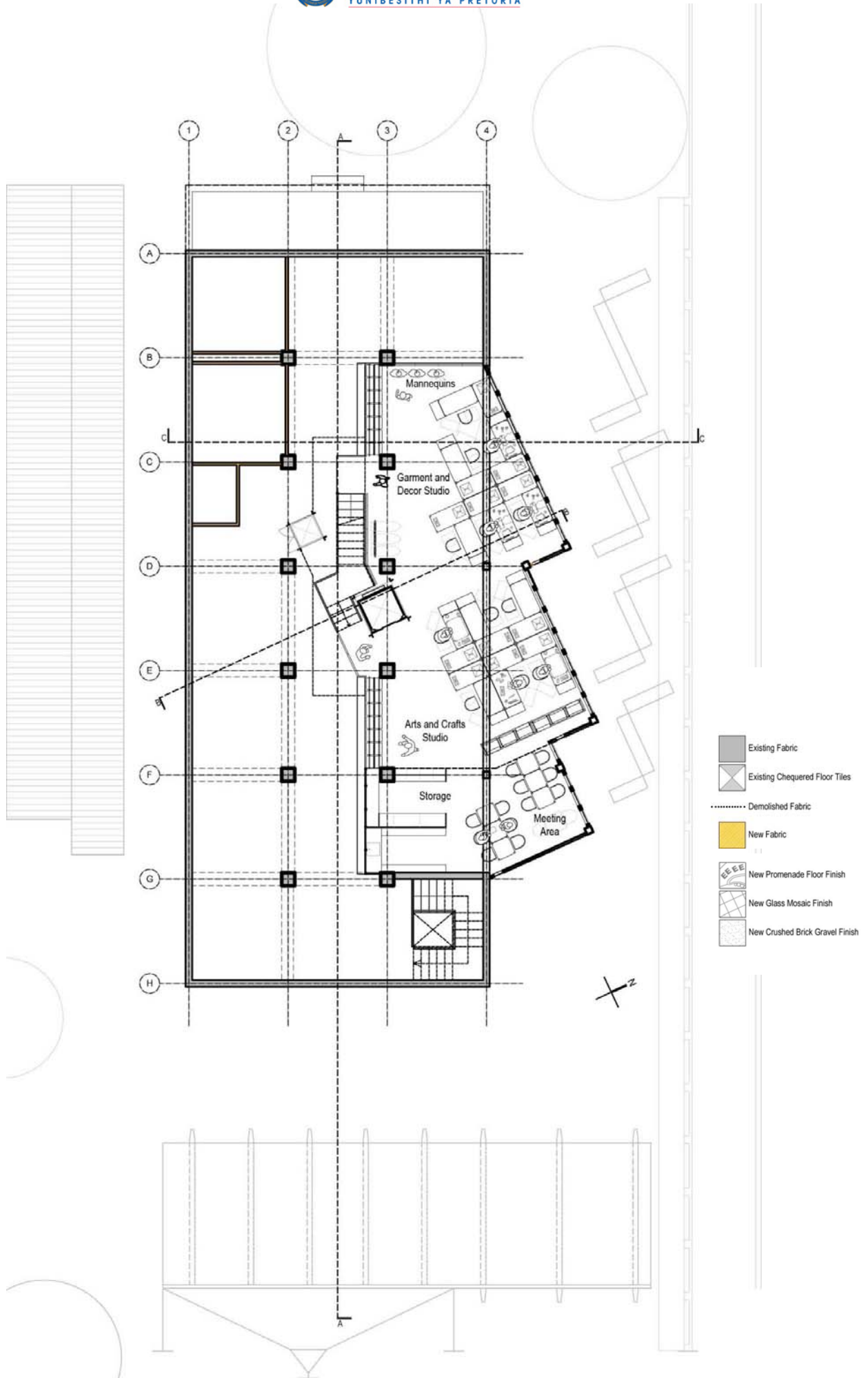

Illus 5.34 Mezzanine 1 Floor Plan (Studios) - 1:200 (Author, 2011)

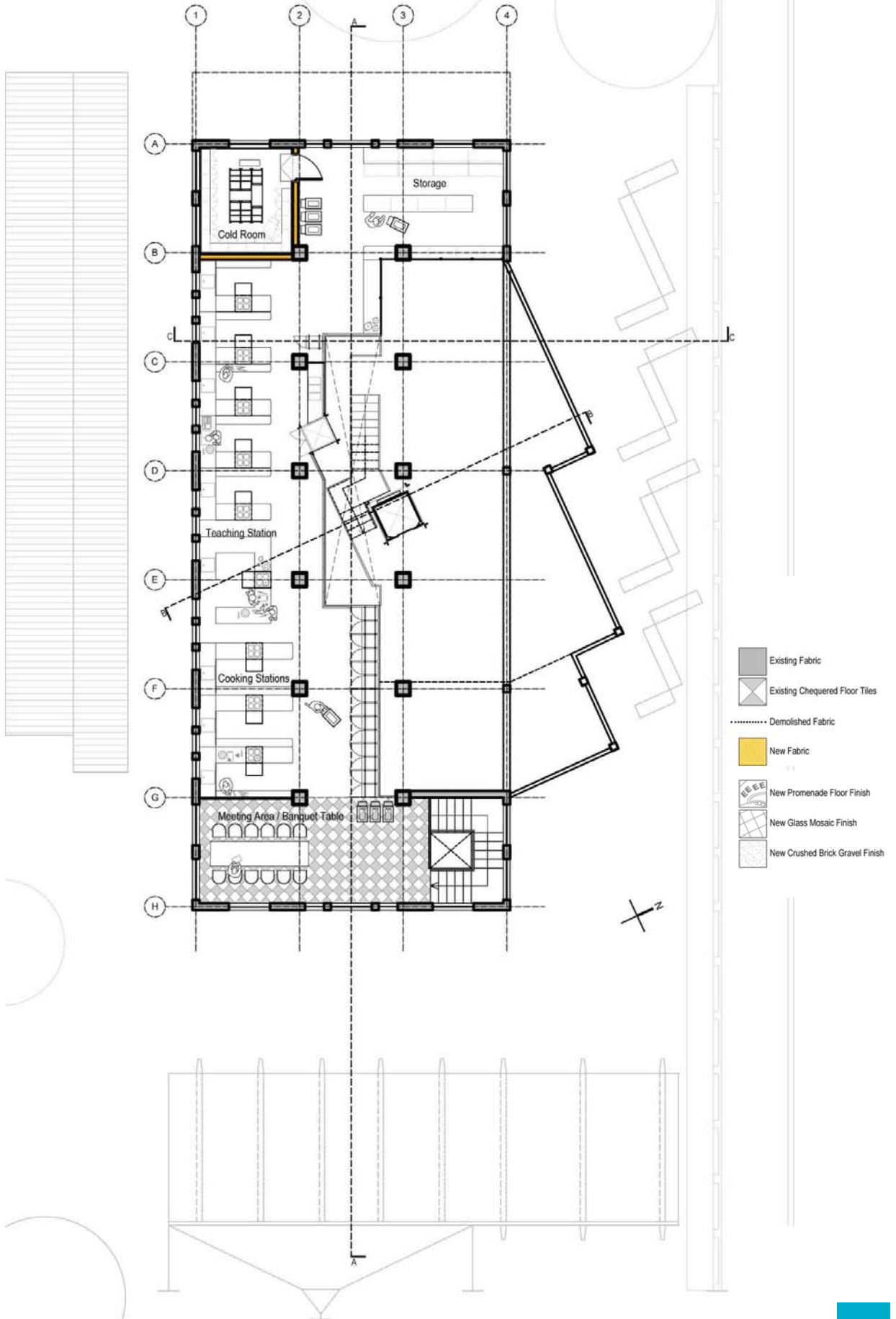

Illus 5.35 First Floor Plan (Food LAB) - 1:200 (Author, 2011)

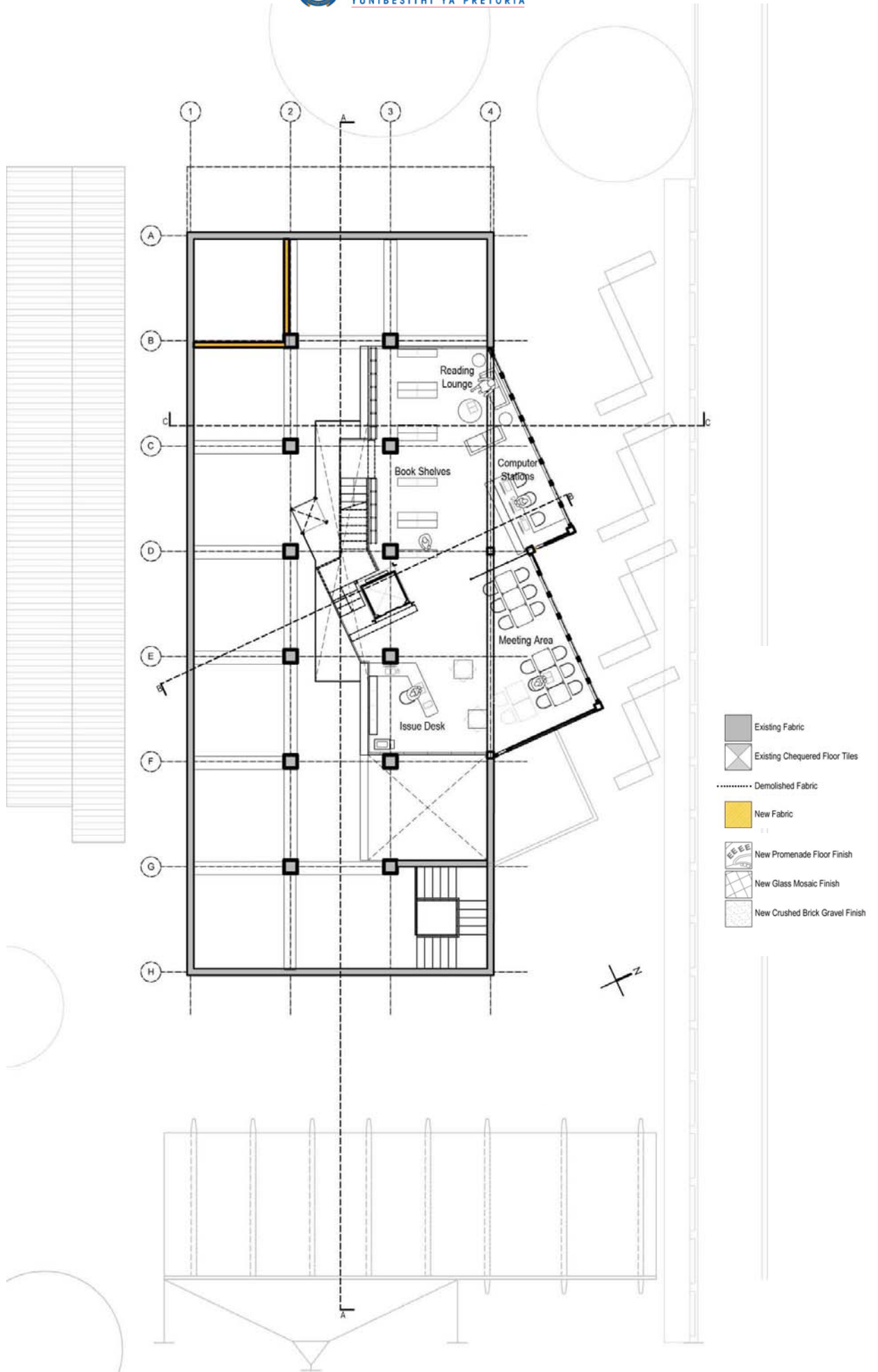

Illus 5.36 Mezzanine 2 Floor Plan (Media Centre) - 1:200 (Author, 2011)

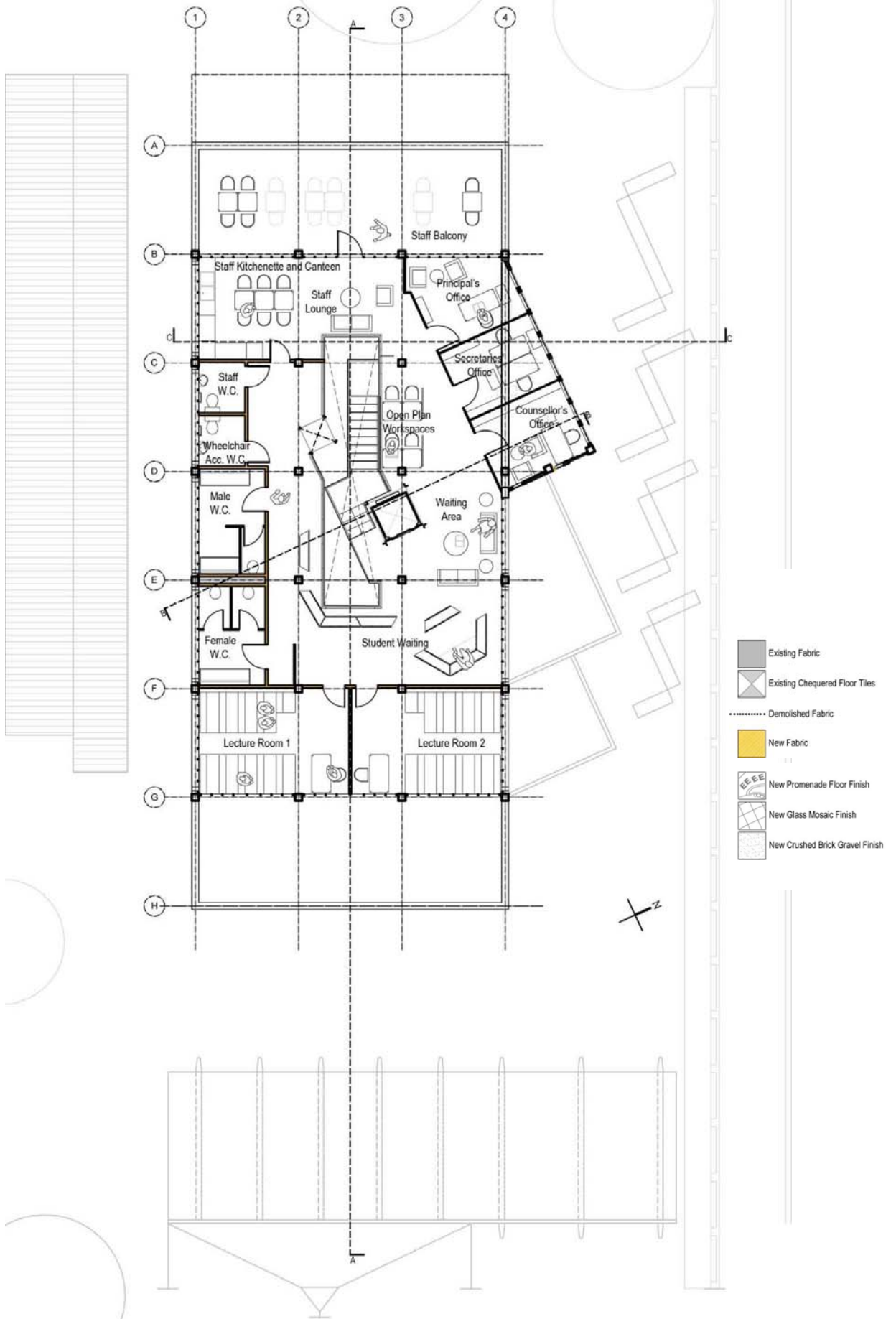

Illus 5.37 Second Floor Plan (Offices, Staff room, Lecture Rooms) - 1:200 (Author, 2011)

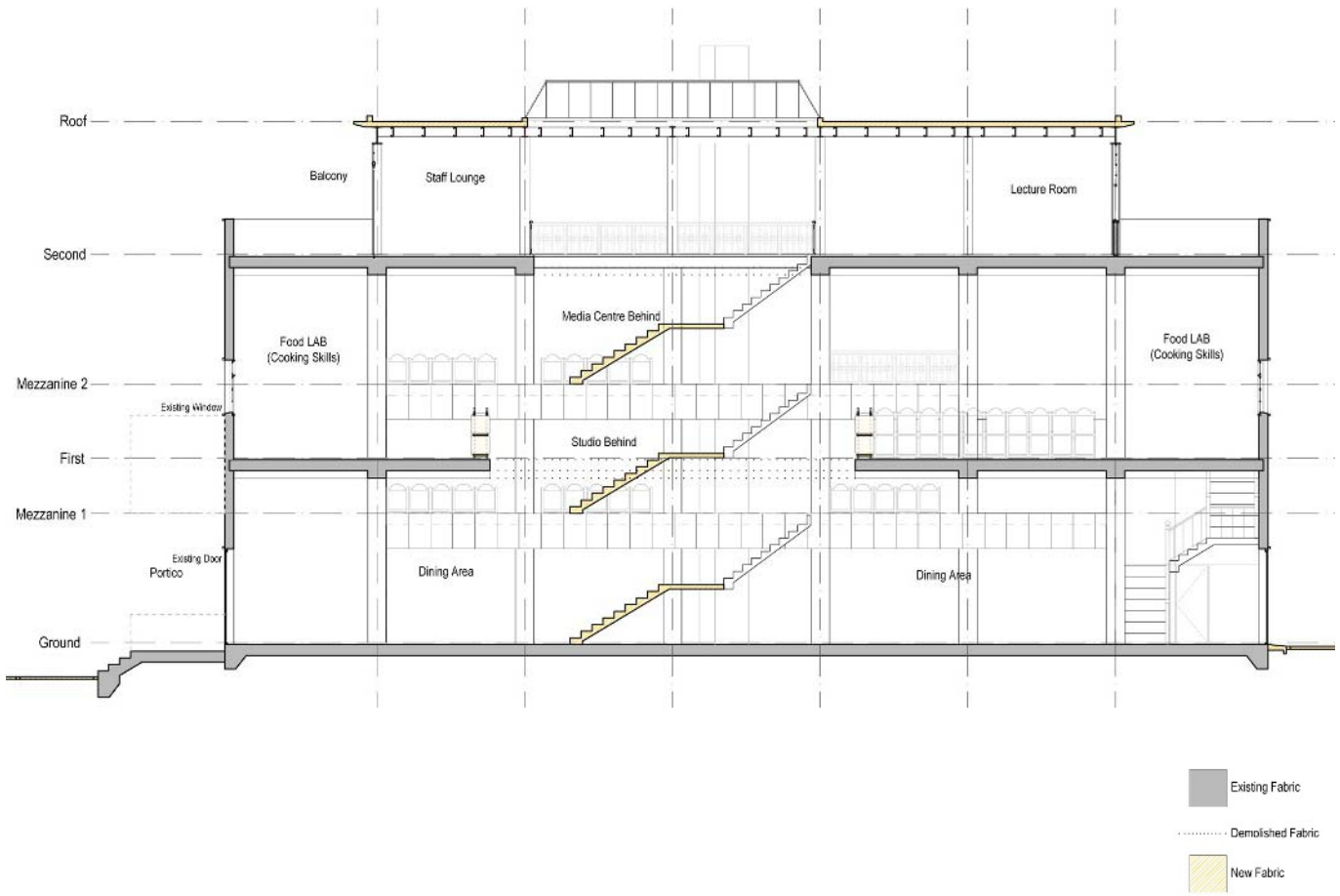

Illus 5.38 Section A - 1:200 (Author, 2011)

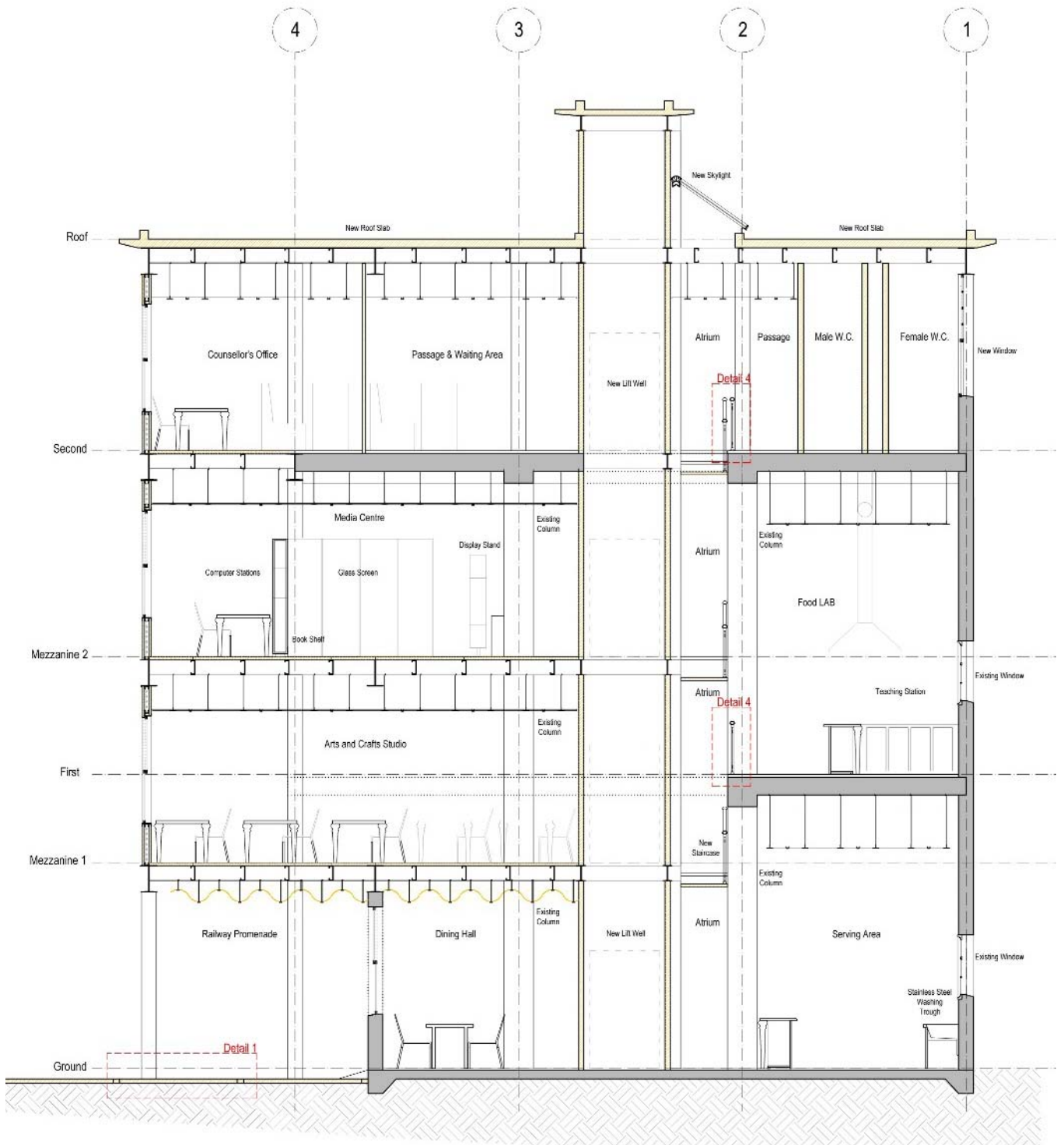

Illus 5.39 Section B - 1:100 (Author, 2011)

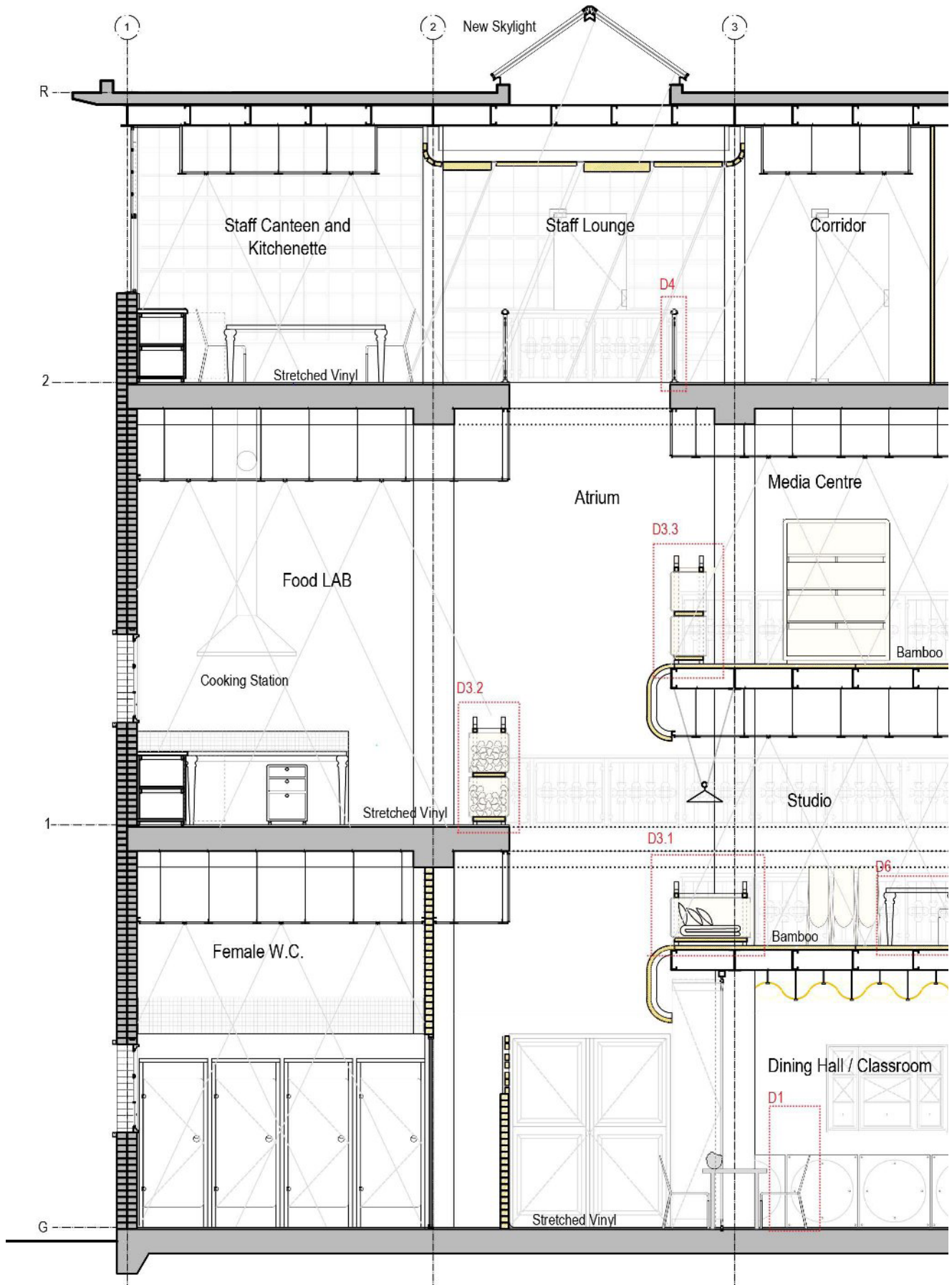

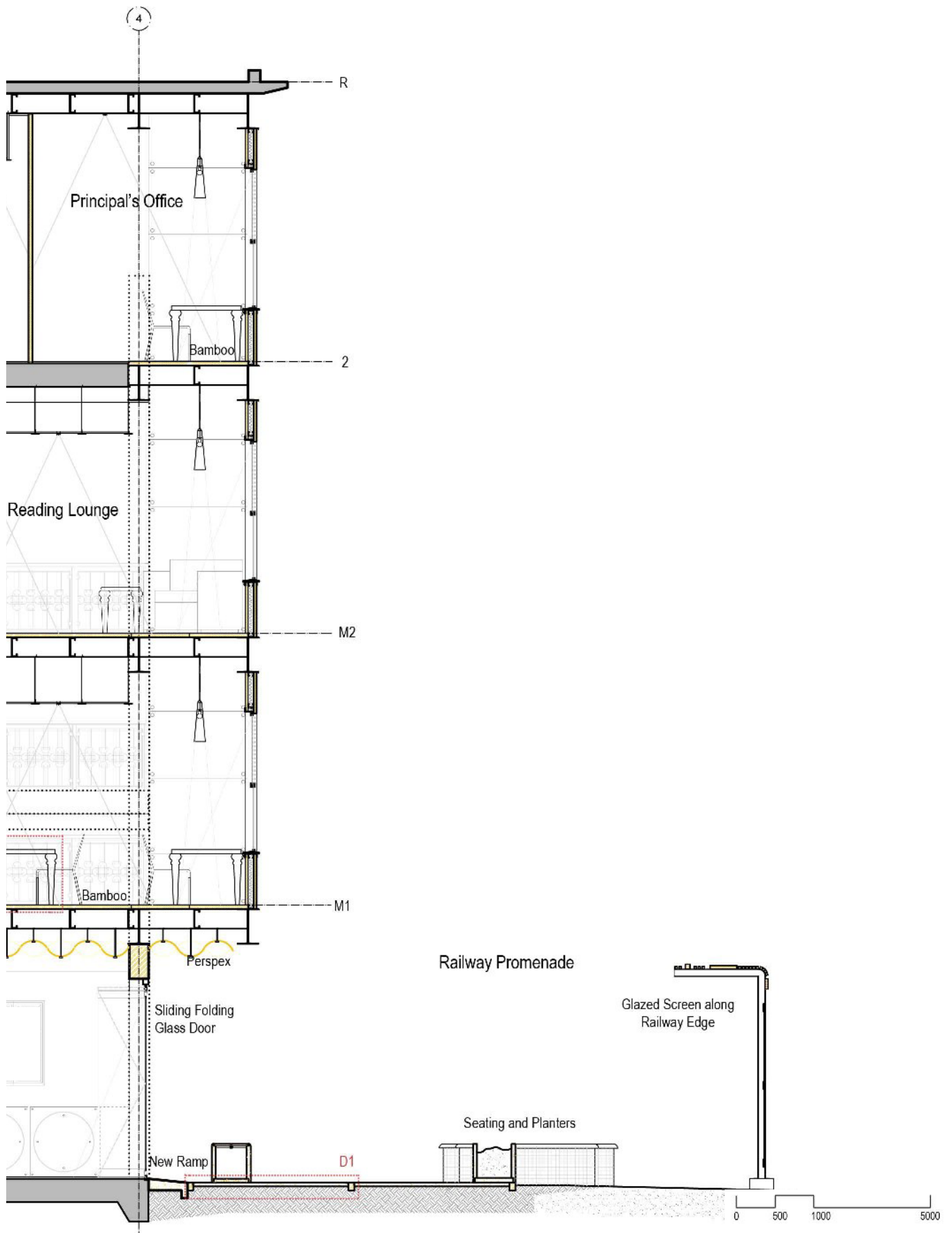

5.8.1 Design Outline



Illus 5.41 View of POPUP building from Salvokop Bridge (Author, 2011)

This view of POPUP from Salvokop Bridge is indicated in Illus 5.41. This is a significant view point and passageway, which is encompassed in the framework design as a route which intersects Salvokop Square. This is the major pedestrian route between Salvokop and the city.

Here, the 2011 POPUP is shown within the landscape and industrial context of Salvokop's railway buildings and abandoned open spaces to be designed as a new landscape route within the framework.

The new transparent floor (second floor) is an addition to the building and improves visibility into current POPUP activities, while reflecting that the 1909 CEO has experienced transformation.



Illus 5.42 Entrance to POPUP (Author, 2011)

Illus 5.42 depicts the entrance to the building via the information and direction structure east of the 2011 POPUP.

The pedestrian entrance is shown as a direct route into this rectilinear space. Also shown is the sculpture court and waiting area outside the 2011 POPUP, with concrete boxes of different heights (450 and 900 mm) to facilitate exhibition or seating. These boxes are to be acid etched with the POPUP logo, painted orange or left as raw concrete. The angle of the boxes and tiles reflect the new geometry of the Northern facade, extending the sense of transformation to the building exterior.



Illus 5.43 View of POPUP building from Railway Line (Author, 2011)

Illus 5.43 demonstrates the relationship between the building and the railway line. Salvokop residents often walk along the railway edge, and the new promenade should provide a pleasant walkway which involves the railway atmosphere.

The new geometric mezzanine floors, projecting beyond the historical skin are also depicted. This would be visible from the city side which is opposite the railway line. The geometric facades are potential for branding through visible signage.

The stepping up of the facades play on the aspiration and upliftment values of the POPUP brand and new logo.

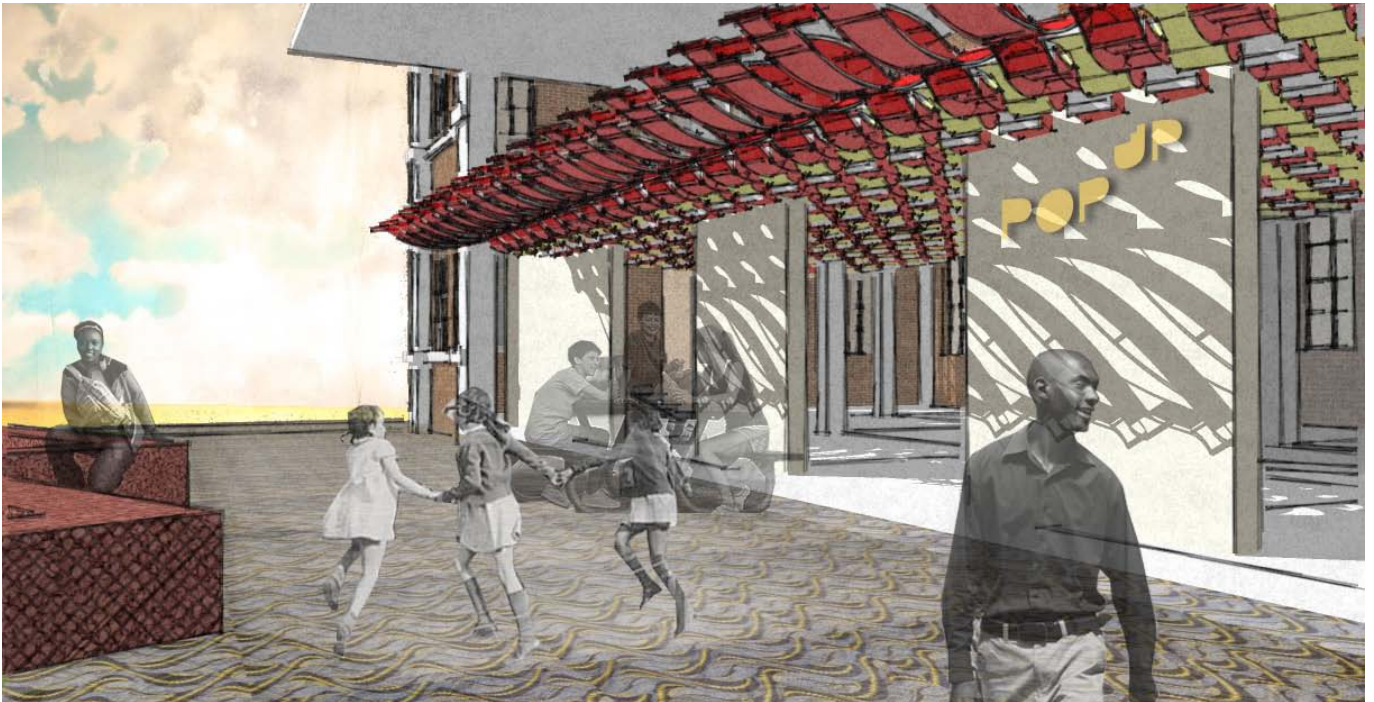

Illus 5.44 Railway Promenade (Author, 2011)

The railway promenade, shown in Illus 5.44, demonstrates the conceptual intentions of pattern, light and texture. The new folding ceiling extends beyond the dining hall to encompass outdoor space as a continuation of the interior space. The use of translucent *Perspex* as the ceiling material will allow the passage of colourful light and shadow to be cast onto the facade in a variety of patterns and positions throughout the day.

The gabion seating, filled with crushed brick from demolition, refers to the historical, but differs in scale and use. The gabions are organised within the new facade geometry, extending the sense of transformation to the exterior space.

The shwe shwe pattern, which is an inspiration to the new floor paving is shown abstractly and is to be developed in detail.

Ground Floor

The entrance (Illus 5.43) to POPUP has been designed to accommodate all visitors to the complex seeking assistance, information and orientation.

A linear path leads directly to the POPUP Student Information and Visitors Centre, a new rectangular steel framed building, which also houses a changing exhibition of art and craft of POPUP students. The sculpture court, which diverges off the linear route (Illus 5.43) is scattered with concrete boxes of varying heights for seating and exhibition. This court space leads to the entrance of the skills centre and is a waiting area for learners and staff of the skills centre.

The skills centre retains the historical eastern entrance to the building. Chequered tiles on the ground floor are retained. The ground floor (Illus 5.33) is an open space dining hall with modular tables (detail 6) which may be rearranged for classroom purposes in a portion of the space which may be enclosed out of dining hours. The atrium, located centrally within the building, acts as an orientating device, through establishing hierarchy and directing attention to the serving area, also located centrally.

The dining hall walls are treated with a wallpaper reinterprets the historical wallpaper and is inspired by POPUP artworks (c.f. 6.7.2), while adding pattern and texture to the space.

The new *Perspex* ceiling panels in translucent red and yellow add interesting light and shadow, as well as colour and texture to the interior space.

The dining hall opens out on the Northern facade to the railway promenade which views the railway line, establishing a relationship between the railway line and the building. Additional seating and planting buffer the railway line from the building edge without obstructing views. The shwe shwe inspired floor tiles (detail 1) of the promenade continue the sense of pattern and texture to the exterior while reinterpreting the “historical ideal” of the chequered floor tiles.

Mezzanine 1

The garment and decor manufacturing studio and the arts and crafts studio share the mezzanine 1 floor (Illus 5.34). The introduction of a new steel structure to support the intermediate floors gave rise to opportunity for a new floor material; panels of engineered hardwood bamboo. The floor panels continue over the steel edge and to the ceiling below as seen in Illus 5.40. The atrium alongside allows visual access from the studios to the dining hall below and food lab above. The edges are furnished with clear storage boxes (c.f. 6.7.5) which take advantage of the visual exposure along the atrium, through exhibiting decor and craft in the process of manufacture.

Tables for the arts and crafts studio and the meeting area are modular (c.f. 6.7.6) and maybe rearranged. A specialised screen for fabric rolls (c.f. 6.7.7) has been designed to screen off studio space from meeting space. Rolls can be removed and taken to the sewing stations or they may be measured and cut at the meeting tables over loose cutting mats.

First Floor

The food LAB for cooking skills training is located on the first floor (Illus 5.35). The chequered floor tiles are retained and complemented with a large glossy red wooden banquet table for class discussions and charity banquets.

The cooking stations are designed according to functional use and materials such as bamboo, stainless steel and caesar stone are utilised for surfaces related to washing, chopping, cleaning and preparing of foods. A cold room has been proposed, with island unit stainless steel baskets and glass cupboards along the edges. Fruit and vegetable storage boxes (c.f 6.7.3) exhibit ingredients along the edge of the atrium to mezzanine 2 above and mezzanine 1 below.

Ingredients are delivered to the food LAB from the ground floor via the escalating platform, which allows ample space for 1 wheelchair or 1 trolley.

Mezzanine 2

The media centre, to be used by learners, staff, teachers and occasionally the public, is located on the mezzanine 2 floor (Illus 5.36). The exhibition of stored books in the book box (c.f. 6.7.3) is found, once more, along the atrium edge, lending an idea to the activity within the space based on its storage. Meeting tables (c.f. 6.7.6) are modular and may be re arranged. Lounge furniture (c.f. 6.7.5) is also modular and may be rearranged according to seating requirements of social, corridor or bench formats.

Second Floor

The second floor (Illus 5.37) comprising mainly of lecture rooms and offices, looks down to lower floors through the open atrium void creating a visual link between spaces and allowing natural light to flow down from the skylight above (Illus 5.40). Waiting areas are furnished with modular seating (c.f. 6.7.5) as found in the media centre. Offices and meeting rooms are furnished with modular tables of incremental sizes (c.f. 6.7.6). The edges of the atrium void are predominantly circulation space and are treated with a crafted balustrade (c.f. 6.7.4) which reinterprets the “historical ideal” of the waiting areas. Lecture rooms are located east, to the quieter side of the building and accommodate 1 wheelchair in each room.

5.9 CONCLUSION

From this chapter, it may be concluded that the design draft processes in mood boards, models and sketches provided meaningful options for design direction. The process of recording, analysing, criticising and concluding design findings have provided useful outcomes for the design development.

Furthermore, it is recognised that all design explorations of this chapter served to find unity through the process of overlaying ideas, and an intensive process of reviewing which led to the development of plans and sections which embody the conceptual intention.

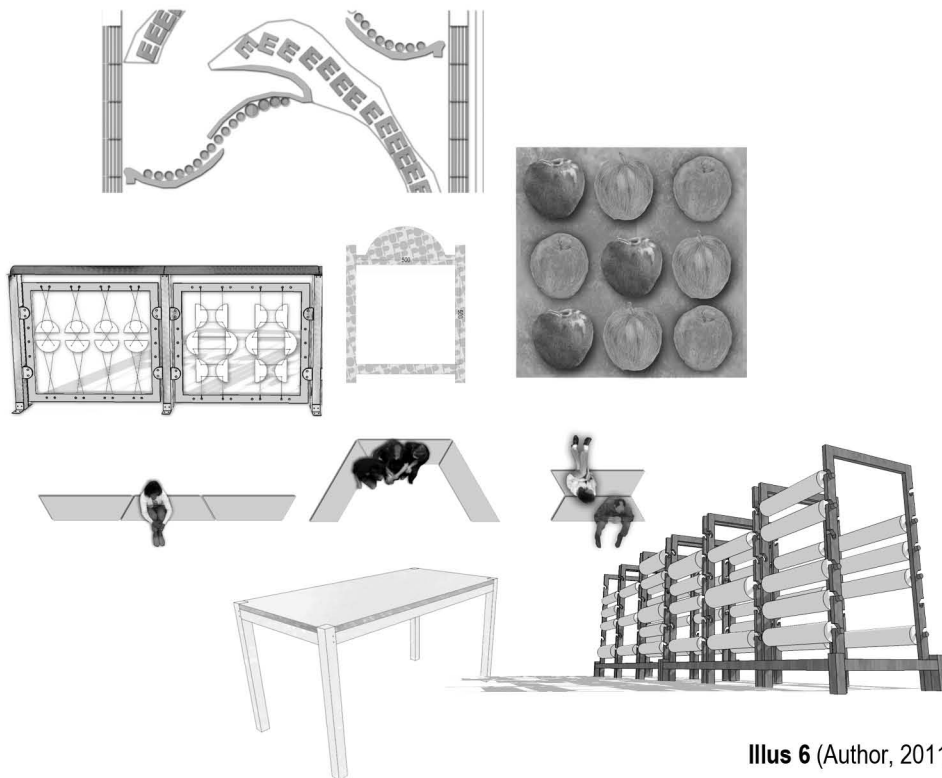

Illus 6 (Author, 2011)



6.1 INTRODUCTION

This chapter will serve to elaborate on the technical development of the design project. The approach to the technical development will be explained and its resolution illustrated in material choice and detailing. Furthermore approach to services, sustainability and inclusive design will be discussed.

6.2 APPROACH

The approach to the technical development of the design was firmly rooted in the conceptual approach in detailing. The concept of reinterpreting and re-imagining the “historical ideal” through current cultural production has informed the design and construction of furniture and the choice of materials and finishes. Allocation of services was a more rational process of orientation (south facade for wet services), spatial requirements (ceilings for electrical and fire) and legislation (fire).



6.3 SERVICES

The distribution of services in the building is as follows:

- Wet services (toilets, sinks, basins) are allocated to the southern side of the building (see Illus 6.1).
- Electrical services are to be allocated within the ceiling voids in each floor to supply lighting and power points (Illus 6.5 - Illus 6.7).
- Natural ventilation is implemented throughout the building due to operable windows. Specialised mechanical extraction systems and fresh air supply are to be provided in the Food LAB (see Illus 6.6).
- Fire escapes are considered through the allocation of two staircases (see Illus 6.1) within the building and sprinklers are to be distributed along the ceiling panels of each floor. Fire retardant finishes are applied to new material.
- Deliveries occur at the portico entrance of the building, which does not disturb the pedestrian nature of the main entrance (see Illus 6.2).

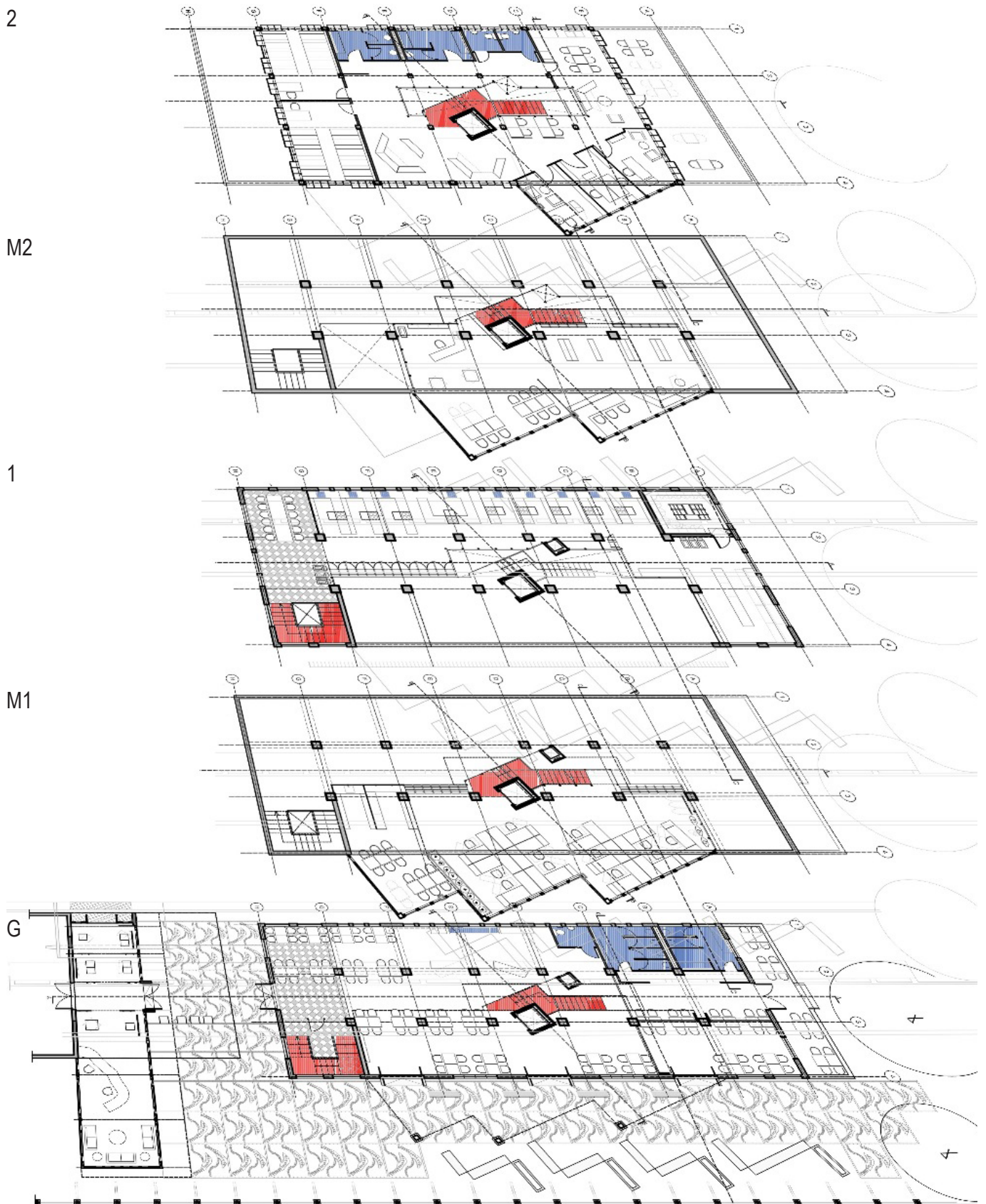

Illus 6.1 Overlay of Plans indicating Services (Red - Fire, Blue - Wet) (Author, 2011)

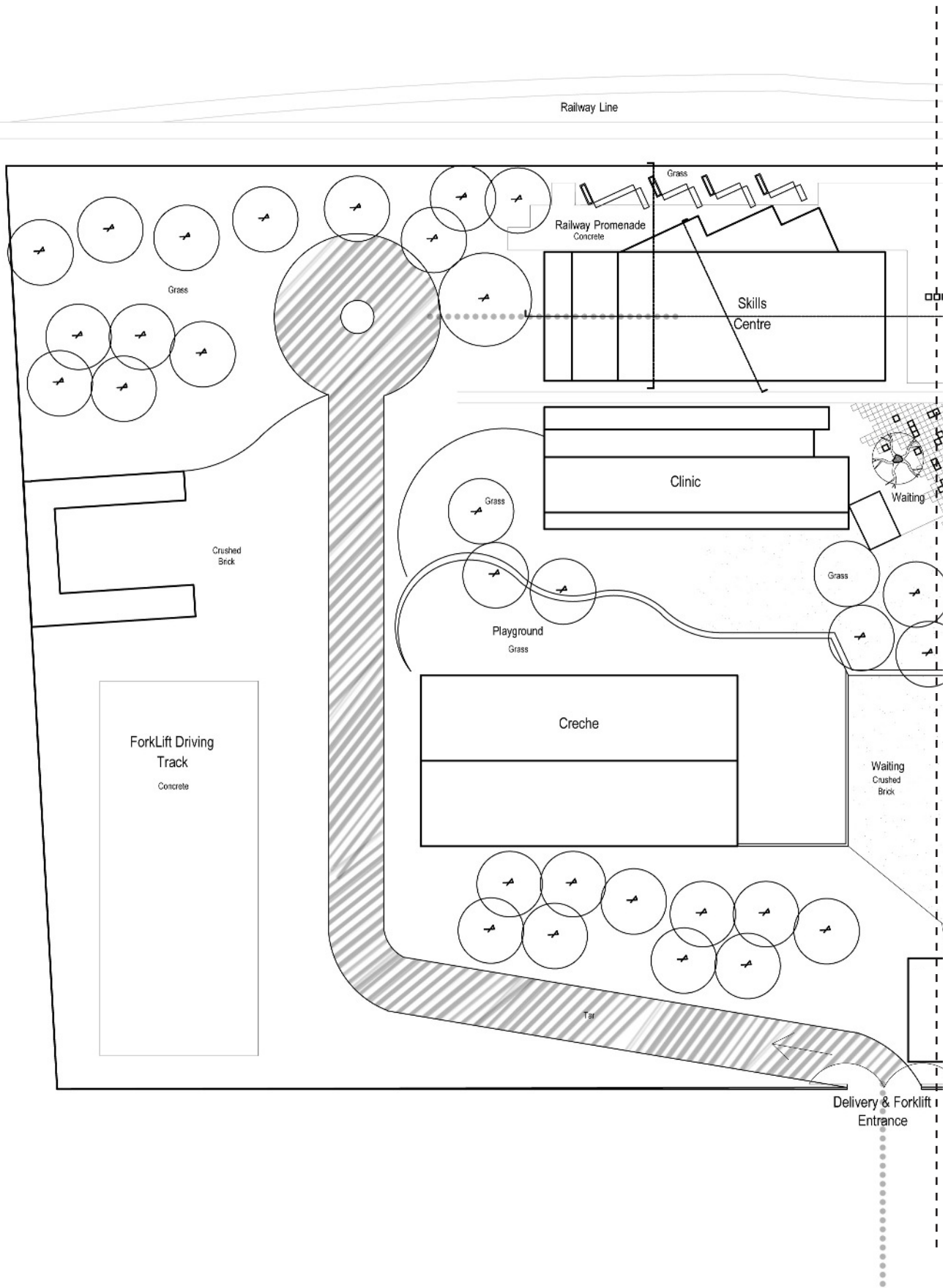

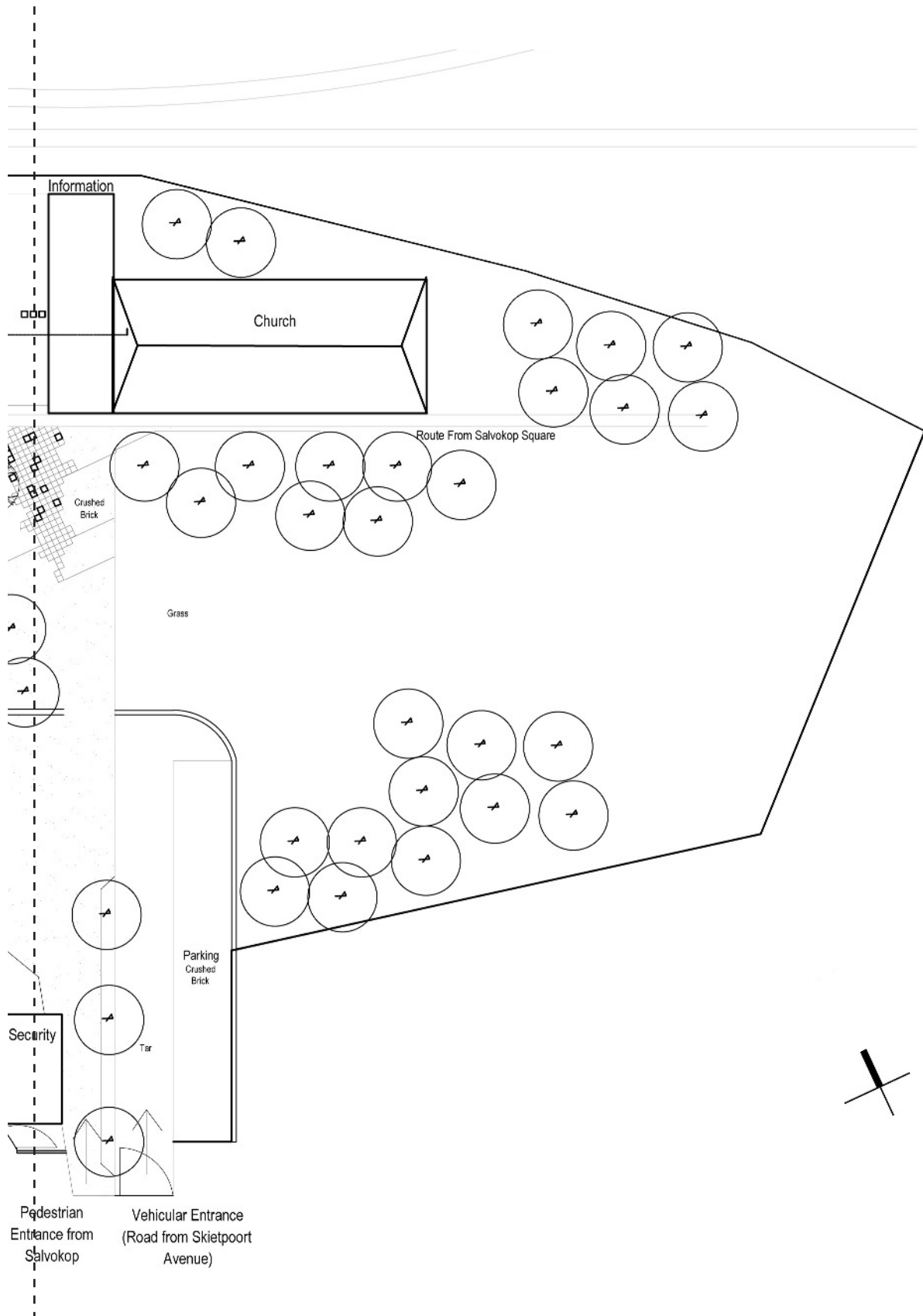

Illus 6.2 Site Plan indicating delivery entrance along west 1:500 (Author, 2011)



Illus 6.3 Fittings (Radiant, 2011)



Illus 6.4 Materials (Author, 2011)

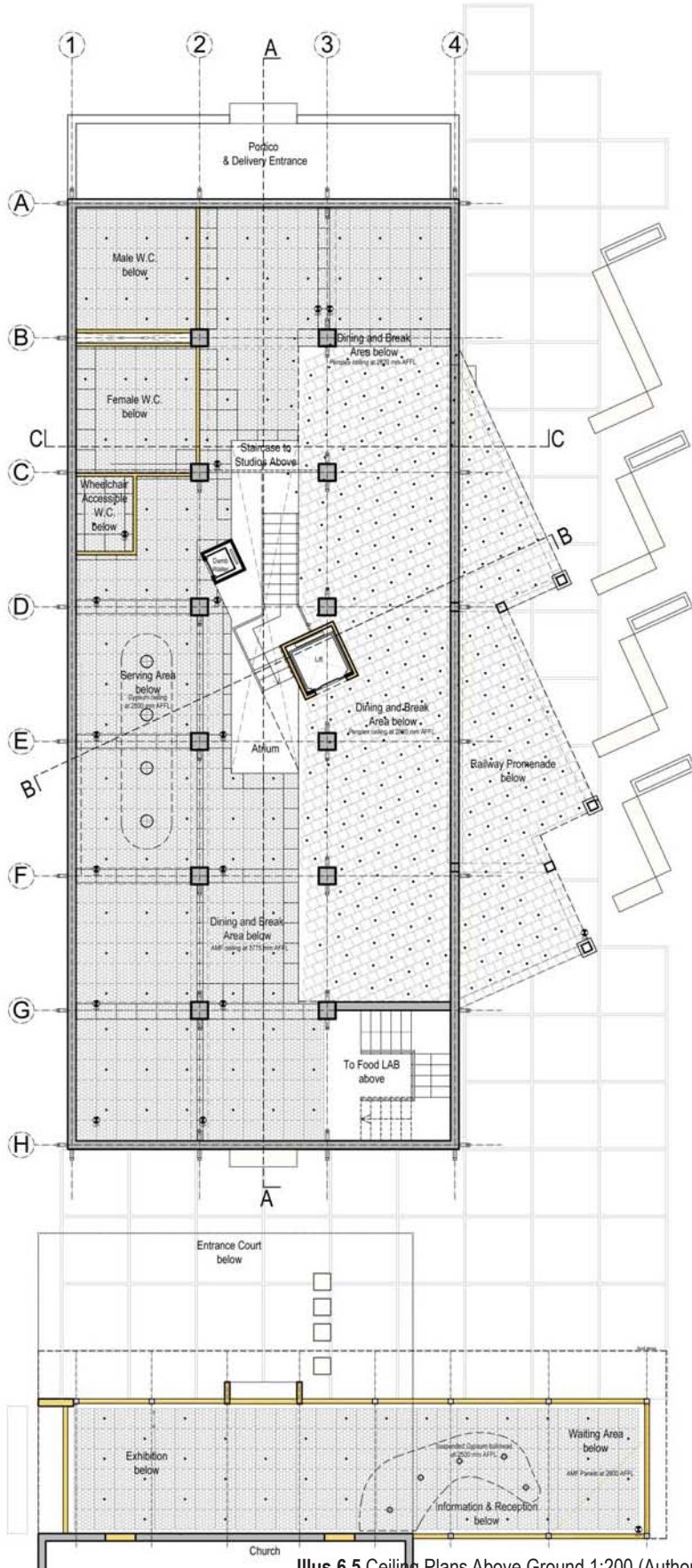

Illus 6.5 Ceiling Plans Above Ground 1:200 (Author, 2011)



Illus 6.6 Ceiling Plans Above M1, Above First 1:200 (Author, 2011)

Key / Legend

- Existing Fabric
- Demolished Fabric
- New Fabric

Ceiling Legend

- 5 mm thick suspended Pelican OWAcoustic Mineral Fibre Acoustic Ceiling Tiles in 600 x 600 mm to be installed as per product specification. (Pelican b, S.A)
- 5 mm thick suspended Pelican vinyl clad ceiling tiles in shell white in 600 x 600 mm size to be installed as per product specification. (Pelican c, S.A.)
- 5 mm thick Pelican AMF suspended ceiling tiles in 600 x 600 mm size to be installed as per product specification. (Pelican a, S.A.)

HVAC Notes

- Fan assisted natural ventilation from window openings for all spaces.
Specialised condition for Food LABS.
- Samsung digital variable multi variable refrigerant flow system
 - Extractor system: Allow for provision of power points to the above and connect up on installation, on - off switch overload for extractor system to be mounted adjacent to extractors.
 - Ducting to take precedent over cable trays and pump fed piping.
 - Air conditioners to switch off in fire conditions.

Ceiling Furniture Legend

- 35 mm di aluminium cased spotlight with warm white 3W LED downlight recessed in ceiling at 1200 mm intervals and 50° beam angle
- 150 mm metal shade with 1W normal cap yellow LED accent lighting with 15° beam angle
- 360 mm metal shade with 1W normal cap yellow LED accent lighting with 15° beam angle
- 90 mm track mounted light fitting with 7W normal cap warm white LED bulb for focused task lighting
- 100 mm aluminium LED wall mounted downlight with 15° beam angle
- 5mm thick heat bent Plexiglas strips in frost red and yellow in 300 x 1200 mm strips suspended from beams above (see Detail 2)
- 270 mm wide bamboo hardwood floor panels
- 600 x 600 mm A/C diffuser
- 600 x 600 mm return air grill
- 600 x 600 mm Stainless Steel Mechanical Extract Hood to extend till 2100 mm AFFL
- Setting out point

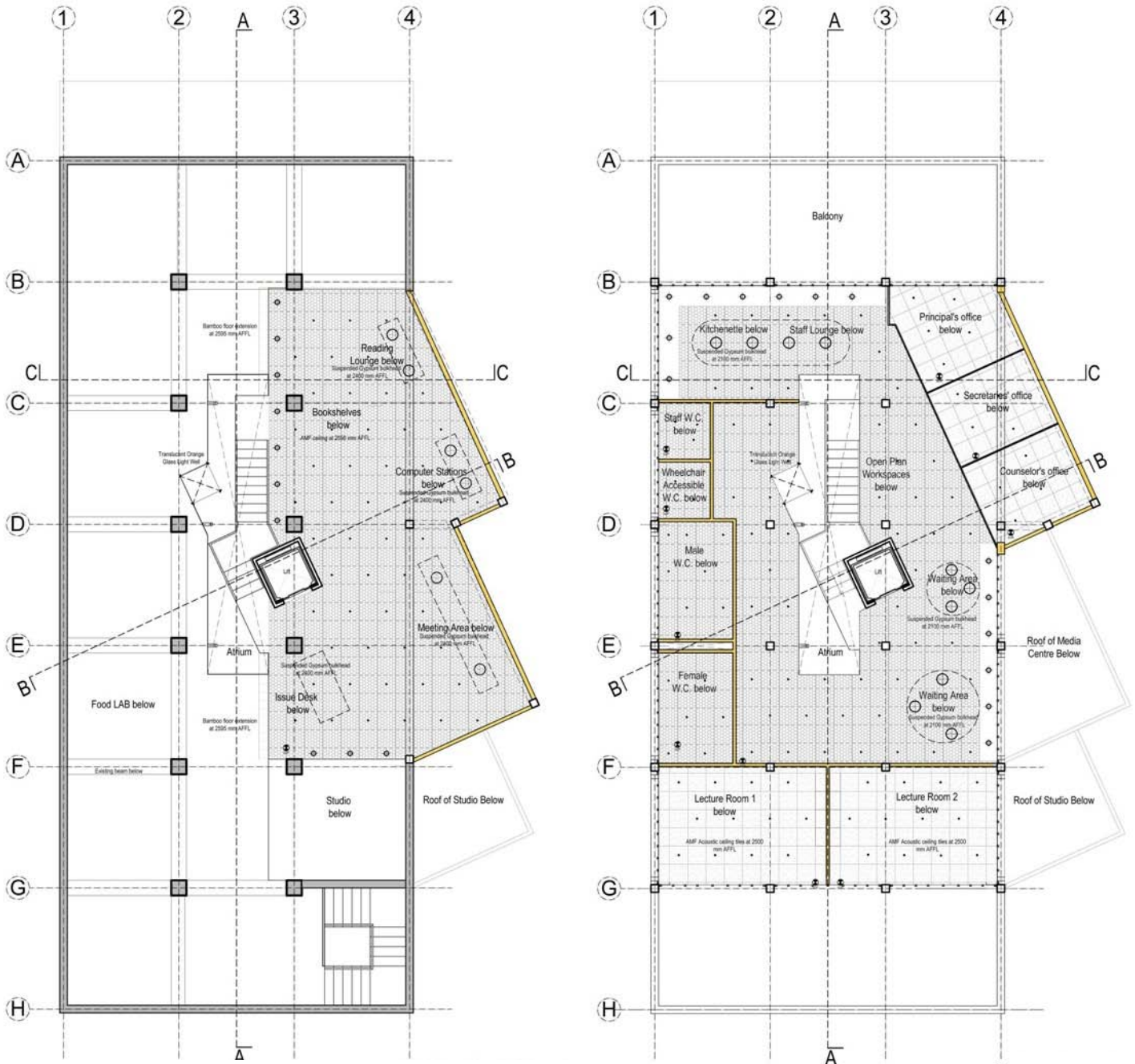

Illus 6.7 Ceiling Plans Above M2, Above Second 1:200 (Author, 2011)



Illus 6.8 Materials and Key (Author, 2011)

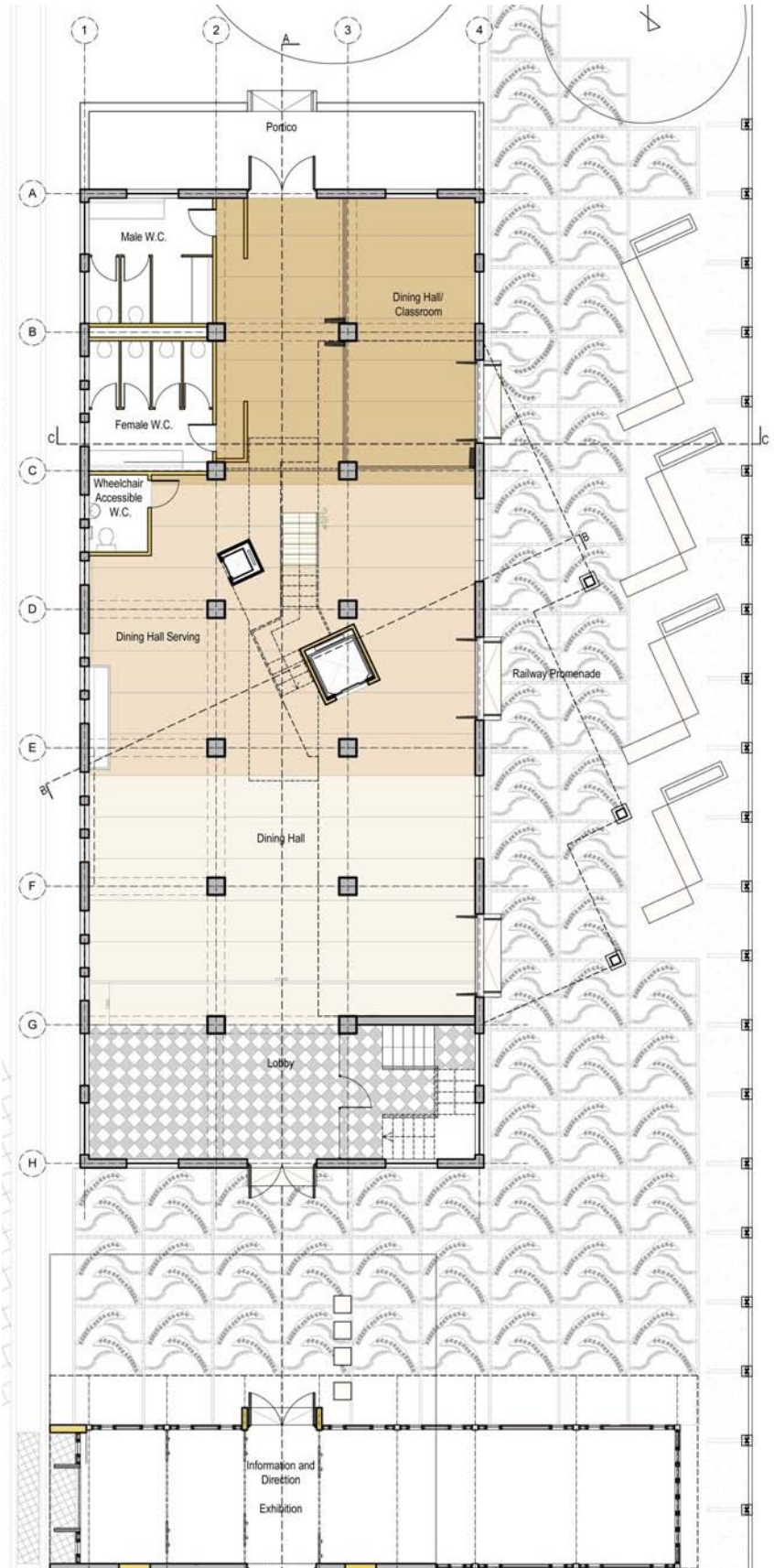

Illus 6.9 Floor Finishes - Ground (Author, 2011)

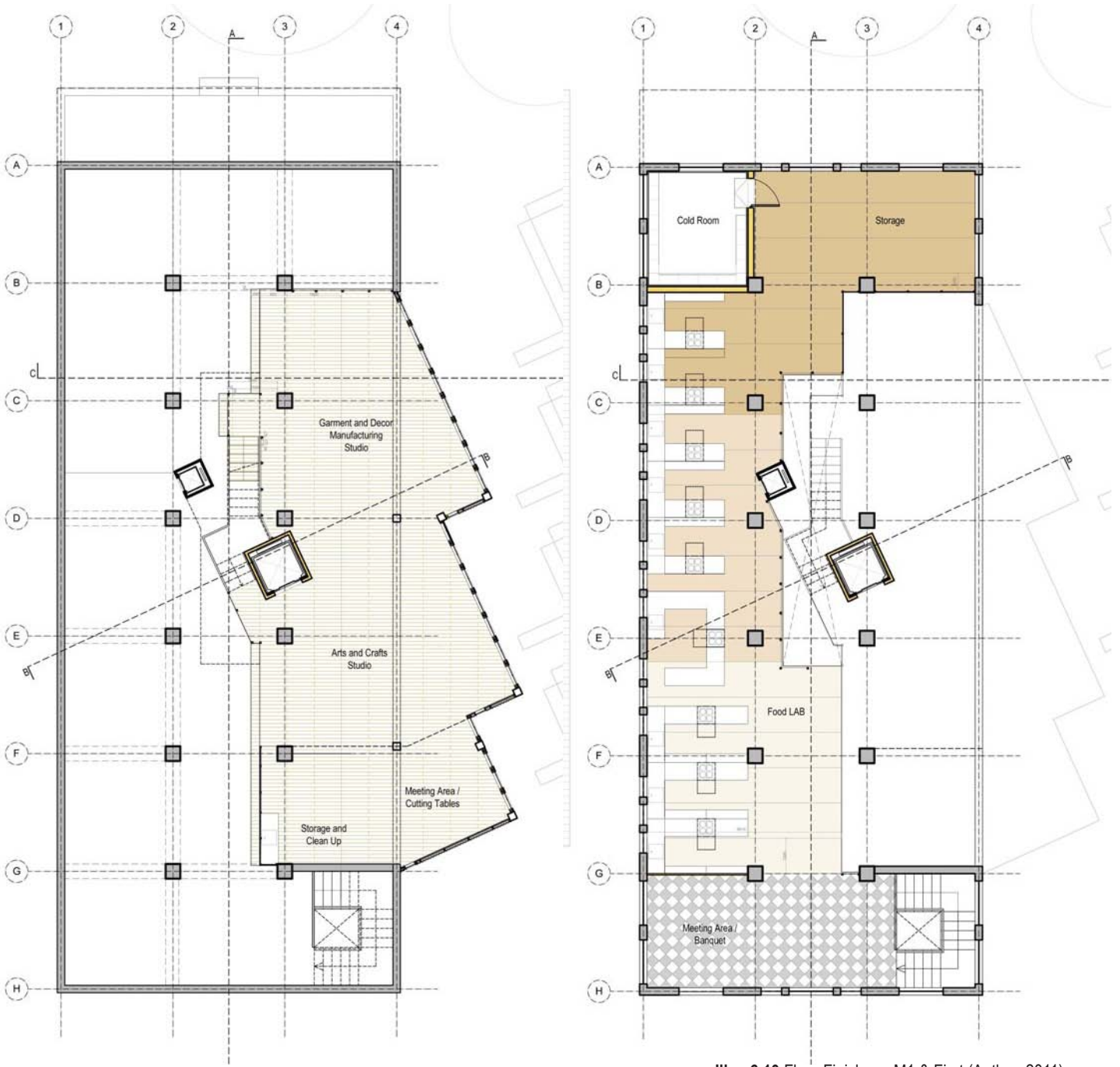

Illus 6.10 Floor Finishes - M1 & First (Author, 2011)

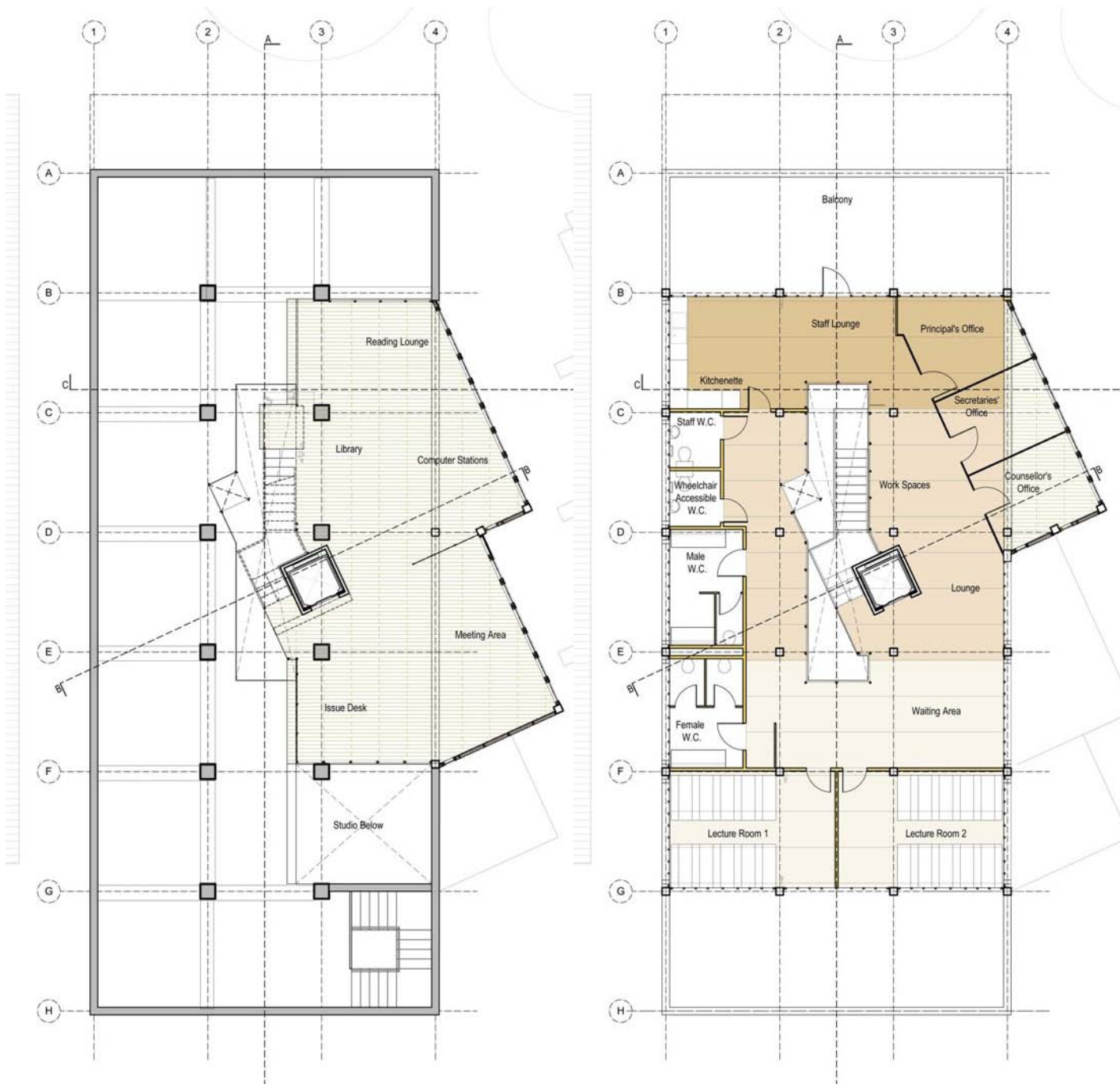

Illus 6.11 Floor Finishes - M2 & Second (Author, 2011)

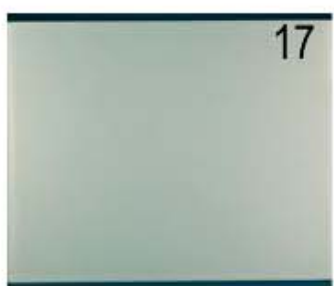
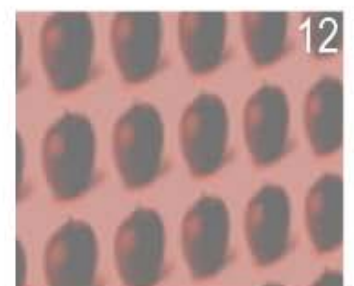
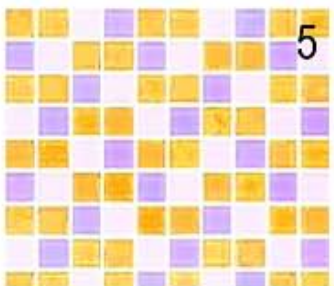
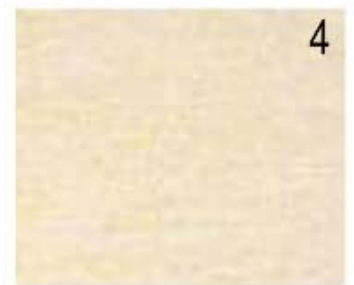

6.4 MATERIALS

1. Mild Steel Structure for the construction of Mezzanines.
450 x 250 mm Galvanised mild steel cold rolled I beams
250 x 150 mm Galvanised mild steel cold rolled I beams
250 x 250 mm Galvanised hollow mild steel square columns
240 x 75 mm Galvanised mild steel C sections (joists for flooring)
2. 100 mm Thick WDVS Weber St Gobain Insulated Exterior Facade Panels to be nailed to structure and finished with cement plaster, with stamped recessed patterns and acrylic paint to product specification (Saint Gobain Weber, S.A.) (See Illus 5.40).
3. 20 mm Thick PG Bison black Formica Solid Core interior cladding in 3050 x 1220 mm sheet sizes laminated with custom printed melamine impregnated paper bolted to interior of steel facade structure (PG Bison a, S.A.) (See Illus 5.40, Illus 6.33 - Illus 6.46).
4. 2.5 mm Thick *Floorworx Superflex* Sheet Vinyl in *MS051 Wheat (S 1010-Y20R)* in 1.2 x 15 m lengths to be applied on dpm and fixed with *Floorworx No. 60* and acrylic adhesive to product specification (Floorworx, S.A.) (See Illus 6.9 - Illus 6.11).
5. 3 mm Thick Glasstile mosaic glass tiles in orange (275) mid grey (095) and dark grey (090) in 50 x 50 mm size to be applied using latex and white thin set adhesives and grouting (epoxy based grouting and adhesives to be used in Food LABS) to product specification (Glasstile, S.A.) (See Illus 6.9 and Illus 6.22).
6. 15 mm Thick *KAINDL* engineered hardwood bamboo flooring in 127 x 1850 mm lengths joined in tongue and groove, in low gloss *Strand-woven Bamboo Honey* and finished with aluminium oxide urethane to product specification (Flooring Depot, S.A.) (See Illus 6.9 - Illus 6.11).
7. 22 mm Thick PG Bison Supawood Medium Density Fibre Board in 3660 x 1380 mm sheet sizes laminated with custom printed melamine impregnated paper & to be CNC cut and joined using acrylic adhesives (PG Bison b, S.A.) (See Illus 6.23 - Illus 6.27).
8. 5 mm Thick *Perspex* (Poly methyl methacrylate) sheets in matte frost red and yellow, and clear in 3200 x 1930 mm to be heat bent using heat strips to product specification (Perspex, S.A.) (See Illus 6.21 - Illus 6.22).
9. 5 mm Thick suspended *Pelican OWA* Acoustic Mineral Fibre Acoustic Ceiling Tiles in 600 x 600 mm to be installed as per product specification (Pelican b, S.A.) (See Illus 6.7).
10. 5 mm Thick suspended *Pelican* vinyl clad ceiling tiles in *shell white* in 600 x 600 mm size to be installed as per product specification (Pelican c, S.A.) (See Illus 6.6).
11. 5 mm Thick *Pelican AMF* suspended ceiling tiles in 600 x 600 mm size to be installed as per product specification (Pelican a, S.A.) (See Illus 6.5 - Illus 6.7).
12. Custom Printed Vinyl Adhesive Wallpaper applied to clean, smooth and prepared surface (see Illus 6.18 - Illus 6.22).
13. Hand Crafted beaten steel panels to crafter's discretion (see Illus 6.21 - Illus 6.22).
14. Hand Sewn textile scrap to crafter's discretion (see Illus 6.28 Illus 6.33 - Illus 6.39).
15. Lafarge cement concrete poured and dried at 50mm depth (see Illus 6.14 - Illus 6.17).
16. 110 x 220 x 50 mm Corobrick Clay Brick Paving laid on soil (see Illus 6.14 - Illus 6.17)
17. 2400 mm High *Dorma HSW-GI* single point connector glass sliding folding door at 600 mm lengths to product's detail (see Illus 5.40).
18. Peach Pip inlays to be laid to crafter's discretion (see Illus 6.14 - Illus 6.17).
19. Industrial packaging inlays to be laid to crafter's discretion (see Illus 6.14 - Illus 6.17).
20. *PG Bison* custom printed melamine impregnated paper fixed to *Supawood* board and *Formica Solid Core* with high heat and pressure in 3660 x 1380 mm and 3050 x 1220 mm sheet sizes (PG Bison a, S.A.) (See Illus 6.25, Illus 6.27, Illus 6.33 - Illus 6.46).

6.5 INCLUSIVE DESIGN

Inclusive design has been considered through accessibility of space to all persons. Entrances are ramped to ensure ease of access. A lift and staircases have been provided within the building to accommodate vertical circulation.

Wheelchair accessible toilets have been provided on the ground and second floor within proximity of the ablution block for ease of orientation and service articulation.

In the case of fire conditions, the lift would be shut down for safety and the staircase routes indicated in Illus 6.1 are the only means of escape. The *Evac+Chair* (Illus 6.13) has been specified as a solution to fire escape for the wheelchair user and other incapacitated or injured individuals. The chair is guided by another able-bodied individual to glide down staircases and roll across flat surfaces, ensuring speedy and efficient evacuation (*Evac+Chair*, s.a).

An open design platform lift is provided for travel between ground and first floors at a distance of 5m for wheelchair users and 2 trolleys in the case of ingredient delivery.

Directional signage is present outside the building in poles (c.f. 5.5.1) along the primary pedestrian route. The use of the POPUP logo acid etched on the concrete boxes in the sculpture court serves to orientate the user and create a sense of arrival. The POPUP information and direction building exists as an additional guide to the site complex. Directional signage within the skills centre is to be located at the main entrance, lobbies and W.C.s.

Photoluminescent emergency signage is to be located on every floor, directing users to the nearest fire escape and emergency exits in green and white, with fire extinguisher signs being red and white. These are to be suspended from the soffit or steel structure above so that they are 2400 mm above finished floor level. Printed plastic is to be pressed between two layers of clear *Perspex*, which are to be heat sealed and drilled, then suspended using aluminium cables.

Informative signage serves to enlighten the user with a sense of knowledge of a space or exhibition. These are to be located in the exhibition and information portion of the POPUP Student Information and Visitors Centre in the form of changeable roll up screens fixed to the steel beams above. Informative signage will also be located in the dining hall with the purpose of notifying users of daily meals and general notices of the skills centre. This is to be located within the ground floor lobby as a freestanding element.

The use of new bamboo flooring on the intermediate mezzanine levels visually contrasts the finishes on floor slabs and allows the atrium space to be perceived within the context of old and new. Brightly coloured and tactile wallpaper (Illus 6.20) and floor finishes (Illus 6.17) are clues to the difference in spaces. The atrium, as a space washed with natural light, is a visual clue to the circulation core, encouraging a sense of special hierarchy without the need of formal direction.



Illus 6.13 *Evac+Chair* (*Evac+Chair*, 2004)

6.6 SUSTAINABILITY

Although environmental sustainability has not been a primary focus of the study, consideration was given in the design project.

The introduction of new mezzanine levels within the existing volume increases usable floor area and appropriates the existing building to suit the program of a skills training centre.

Flexibility through the design of modular sized furniture (Illus 6. 28 - Illus 6.39) ensures adaptability and minimises cost and use of resources through the provision of identical table units which would be utilised throughout the building.

Bamboo, as a material choice, is sourced sustainably and is a renewable resource. Steel is a material which may be recycled. The use of plant material and industrial waste as floor materials minimises waste disposal through recycling and adds unique value to the building environment.

The new mezzanine levels are oriented to face north, enhancing the thermal and lighting properties of the space. Natural ventilation is used throughout the building, apart from the Food LAB, which utilises low energy ventilation systems of extraction and fresh air supply.

Natural light through the atrium minimises the need for artificial lighting in the dining hall and the second floor during the day. Other rooms require low energy LED artificial lighting to be active due to the task-oriented activities (lectures, studios, LABs, offices) in these spaces and are chosen for general lighting throughout the building, which minimises energy use (see Illus 6.3 - Illus 6.7).

Social sustainability has been considered as a focus of the project.

The use of crafted elements in new design intervention borrows ideas from the historical but is reinterpreted through craft. This ensures a sense of connection with the existing while lending ownership to the building's users through reflecting them. This is demonstrated in the details provided later in this chapter.

The introduction of new mezzanine spaces changes the building's form and reflects transformation in the building's programme, while consequently allowing specialised spaces for certain activities.

The use of the atrium edge allows that spaces of different levels may be able to look across, up and below into each other, improving a sense of visibility and inspiration from different skills fields. The positioning of clear storage boxes (Detail 3) along these edges provide clues of the activities occurring within the spaces behind, while, consequently, exhibiting works-in-progress from each of the spaces.

A sense of arrival to the building is created through a sculpture courtyard and information, exhibition and direction built structure. These serve to orientate the visitor and to also expose the recent work of POPUP students to the public.

6.7 DETAILS

The following details were chosen for development due to their relationship with the design concept. In each case, the “historical ideal” is identified and the re-imagined cultural product demonstrated, with the inspiration for development also illustrated. These elements are significant within spaces in the building and contribute to the new character which borrows from the building’s history but delivers a new and appropriate layer through current cultural production.

6.7.1 Detail 1: Shwe Shwe Floor: Railway Promenade

This floor finish detail, inspired by the patterns of South African traditional fabric, *Shwe Shwe*, reinterprets the surviving historical chequered floor tiles in the building’s lobby and first floor (Illus 6.14).

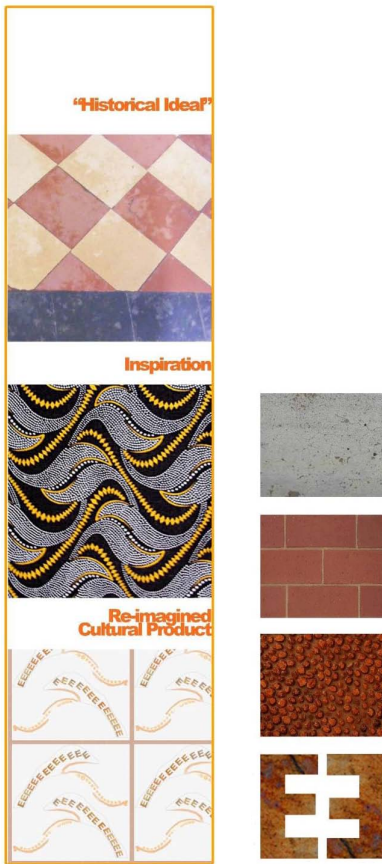

Illus 6.14 Concept and Materials (Author, 2011)

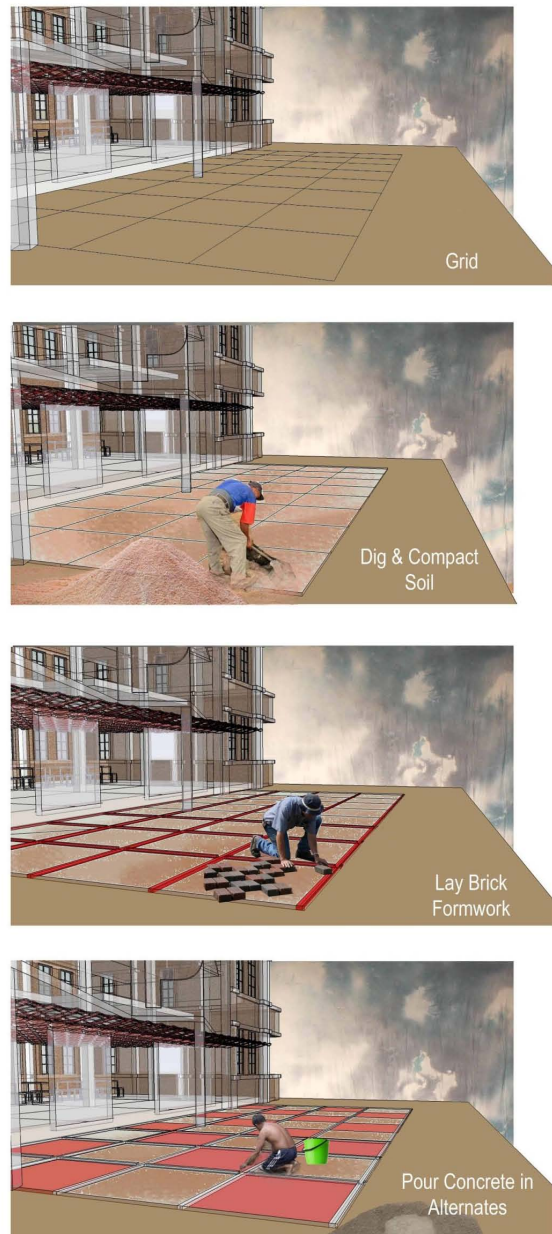

Illus 6.15 Stages 1 - 4 (Author, 2011)

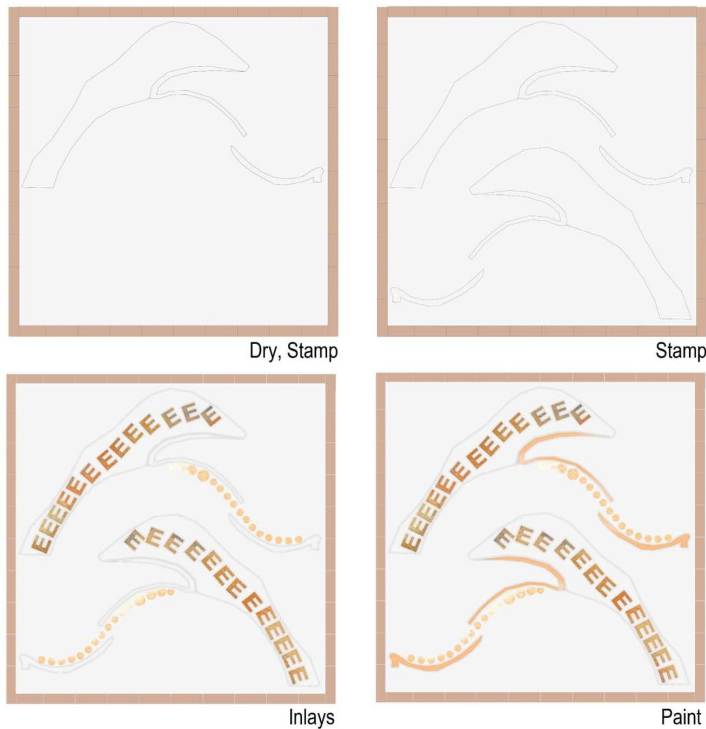

These concrete tiles would be cast by craft learners, then stamped with a steel stencil, drying time will be allowed and then inlays of peach pips and industrial waste packaging placed. Once dry, parts of the concrete will be finished with *Plascon Floor Paint* in satin burnt orange (Illus 6.15 - Illus 6.16).

The result would be a vibrant, tactile, textured floor finish of public pedestrian scale (2 m x 2 m tiles) (Illus 6.17).

Illus 6.16 Stages 5 - 8 (Author, 2011)

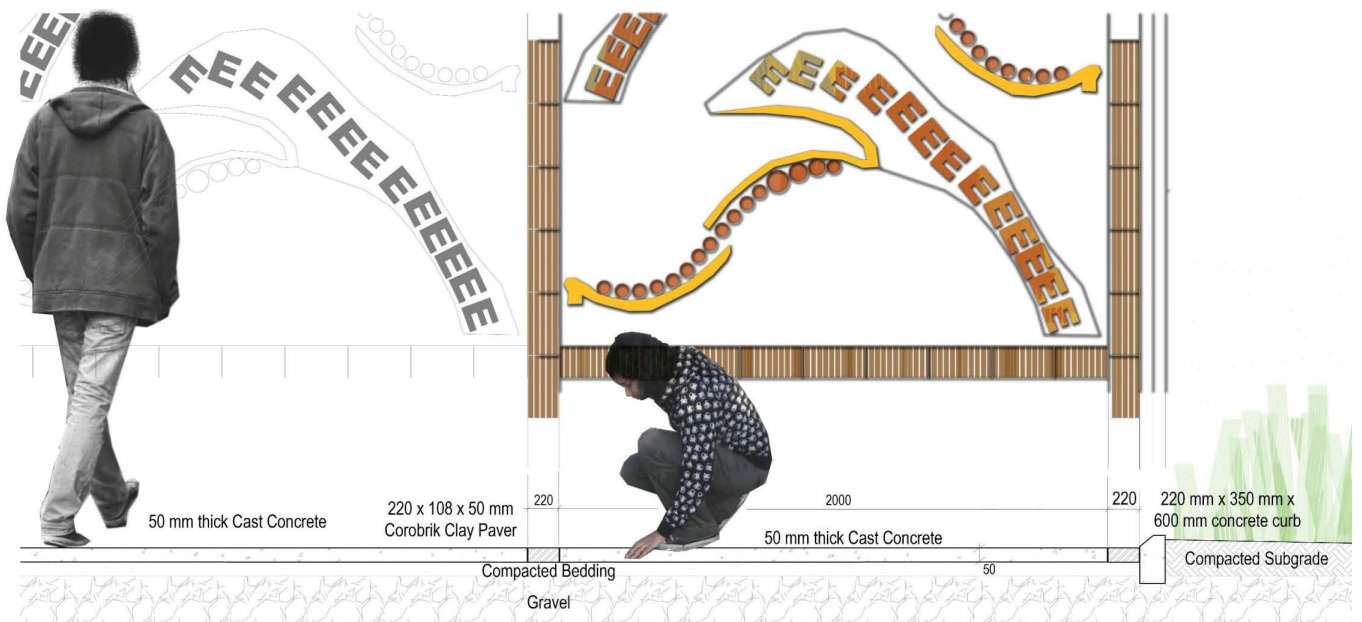

Illus 6.17 Section and Plan 1:25 (Author, 2011)

6.7.2 Detail 2: Wall Finish: Dining Hall

The wallpaper finish, inspired by the apple serves to reinterpret the use of wallpaper in the 1909 interior photograph of the CEO (Illus 6.18). This image, depicted in the mood board in the previous chapter, has given rise to a decorative, patterned, vibrant graphic of apples which are to be taken directly from the artworks of POPUP's Art learners (Illus 6.19). These have been utilised as the main graphic on the wallpaper (Illus 6.20).

Clear *Perspex* panels are bolted to the bottom of the wall, over which crafted beaten steel panels will be fixed. This detail re-imagines the interior of the 1909 CEO in a manner that is culturally inclusive (Illus 6.21 - Illus 6.22).

POPUP Student Artworks

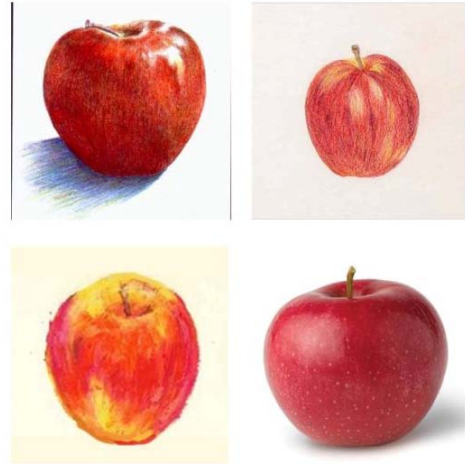

Illus 6.19 Inspiring Artworks (POPUP Students, 2011)

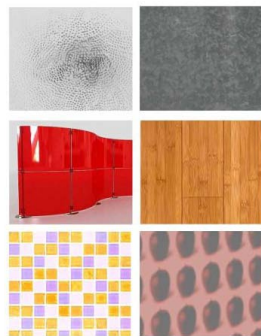

Illus 6.18 Concept and Materials (Author, 2011)



Illus 6.20 Wallpaper Graphic (Author, 2011)

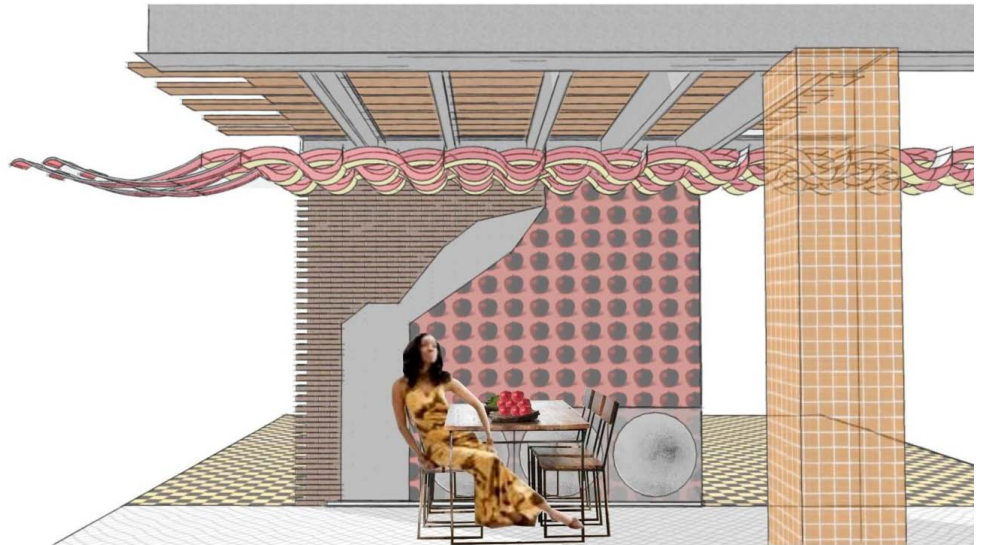

Illus 6.21 Elevation Perspective (Author, 2011)

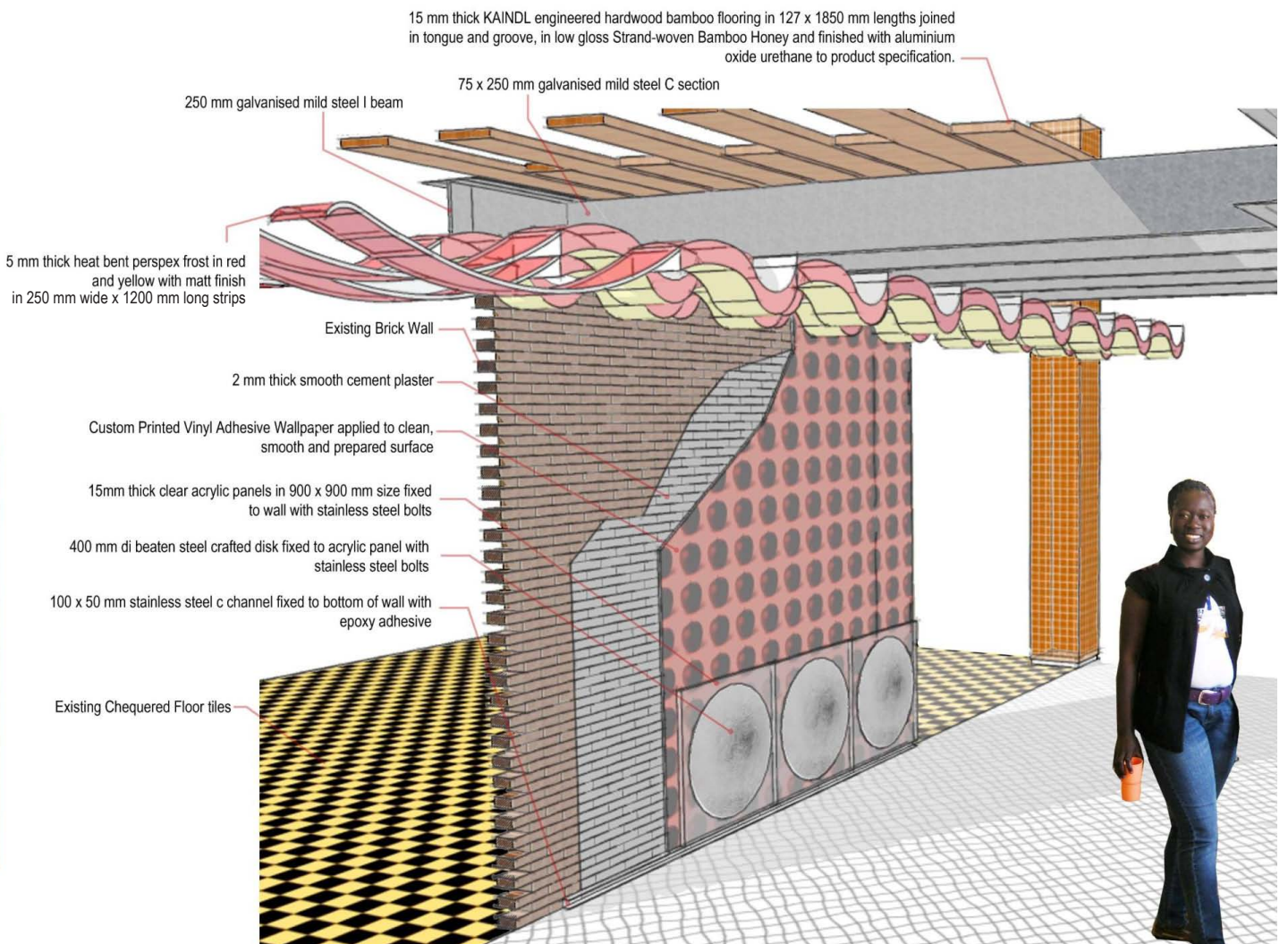

Illus 6.22 Sectional Perspective (Author, 2011)

6.7.3 Detail 3: Storage Boxes: Studios, Food LAB, Media Centre

The storage box variations, inspired by the furniture design exploration in the precedent study, *Jolie Toujours*, seeks to reinterpret and re-imagine the furniture of the 1909 CEO as depicted in the mood board in Chapter 5 (Illus 6.23). These storage boxes represent cultural production through their aim to exhibit stored items along the atrium edge. The transparent heat-bent *Perspex* boxes are visible from above, below and across the atrium, and expose items such as decor in process in the studios, fruit and vegetables in the food LAB and books in the media centre (Illus 6.24 - Illus 6.27). *Supawood* panels are nailed together and fixed using volatile organic compound (VOC) free adhesives.

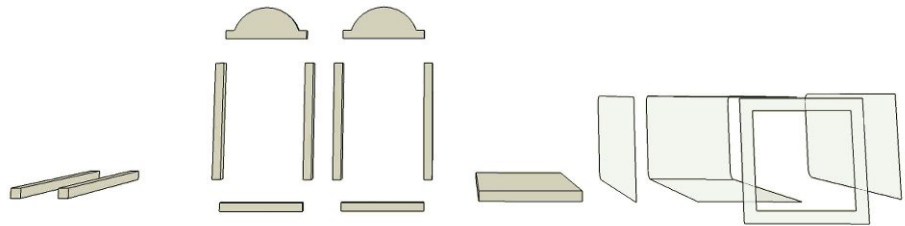
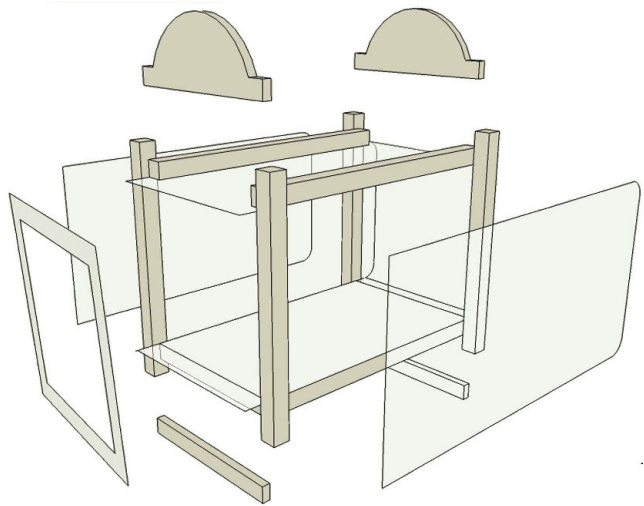

Illus 6.24 Pieces for Assembly (Author, 2011)



Illus 6.23 Concept and Materials (Author, 2011)

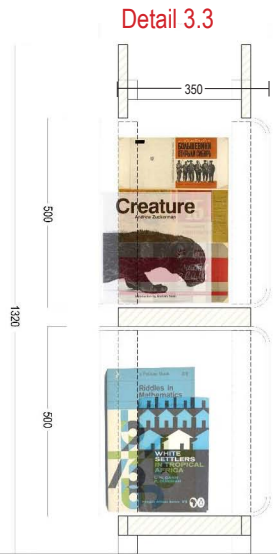
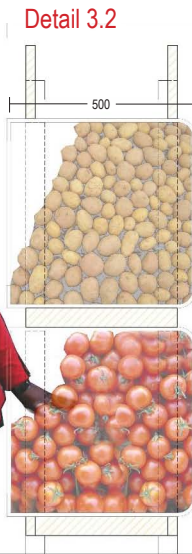

Illus 6.25 Section and Elevation of Food LAB and Media Centre Boxes 1:20 (Author, 2011)

Detail 3.1



Illus 6.26 Section of Studio Storage Box 1:10 (Author, 2011)

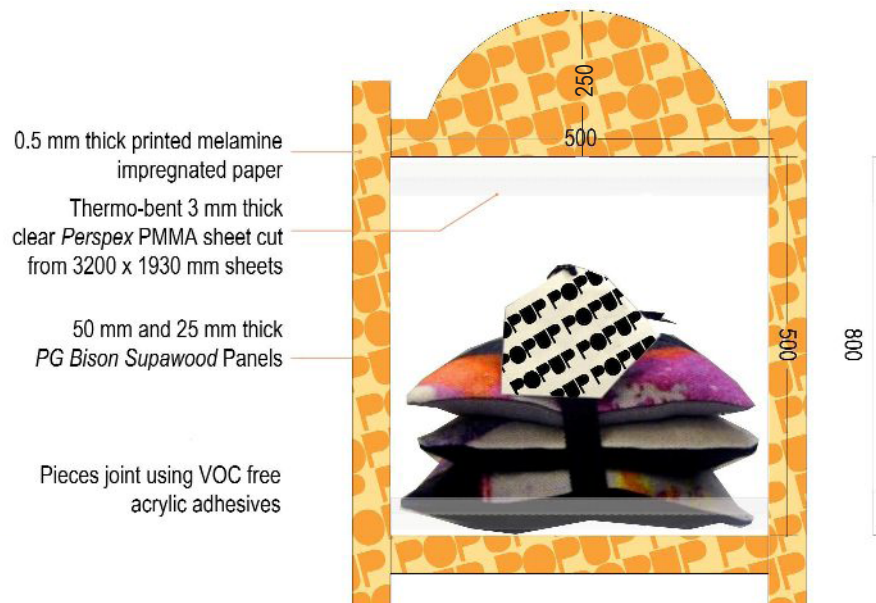

Illus 6.27 Elevation of Studio Storage Box 1:10 (Author, 2011)

6.7.4 Detail 4: Balustrade: Atrium Edges

The balustrade design, informed by the “historical ideal” of the existing cast iron posts, predominantly reinterpret the design of infill between the posts through shape abstraction (Illus 6.28, Illus 6.30). The rose window shape is abstracted to a half circle shape which is used as a basis for infill size. The infill, to be of craft materials such as beaten steel, timber off cuts and textile laminated *Supawood*, are cut and assembled within the frame and fixed with threads of wire, textile scraps or rope on the galvanised steel frame by the craft learners (Illus 6.29, Illus 6.32).

The means and configuration of tying is to the discretion of the crafter and possible options are demonstrated alongside (Illus 6.31).



Illus 6.28 Concept and Materials (Author, 2011)

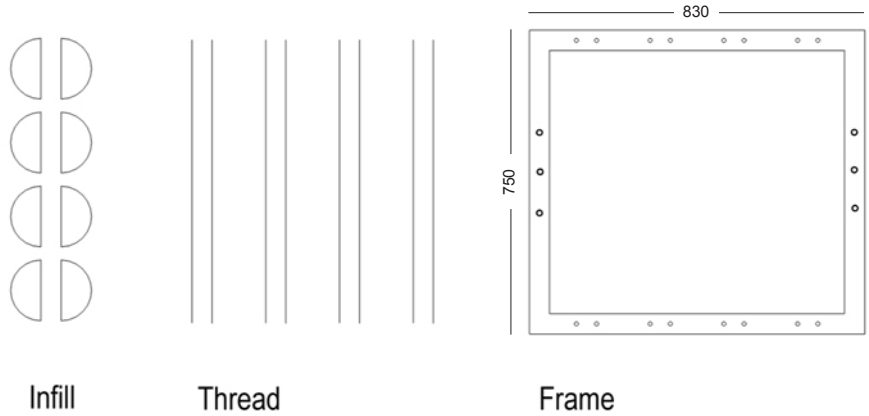

Illus 6.29 Infill, Thread and Frame pieces for crafter's use (Author, 2011)

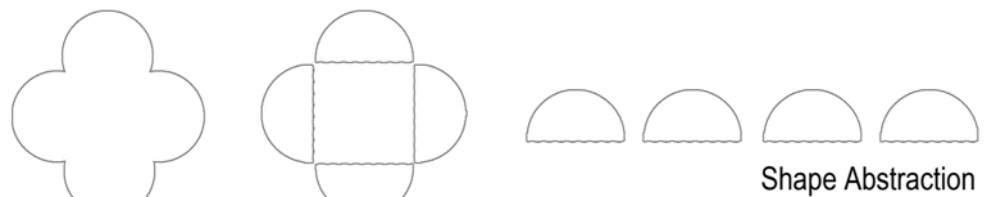

Illus 6.30 Shape Abstraction (Author, 2011)

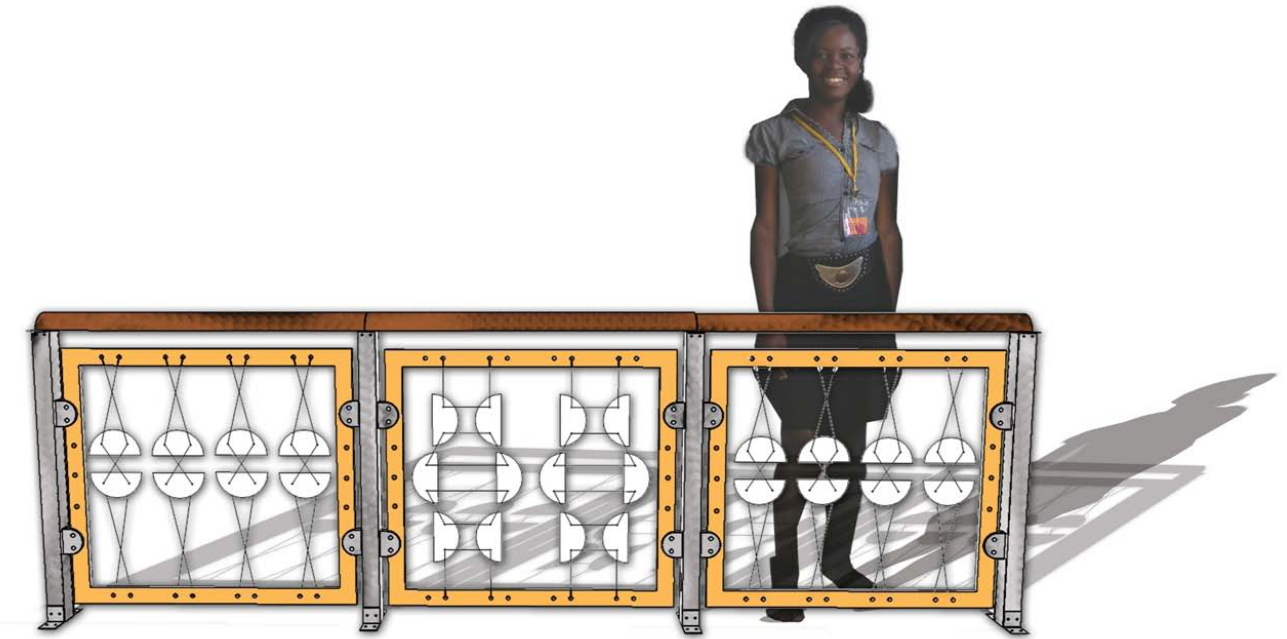

Illus 6.31 Infill Options (Author, 2011)

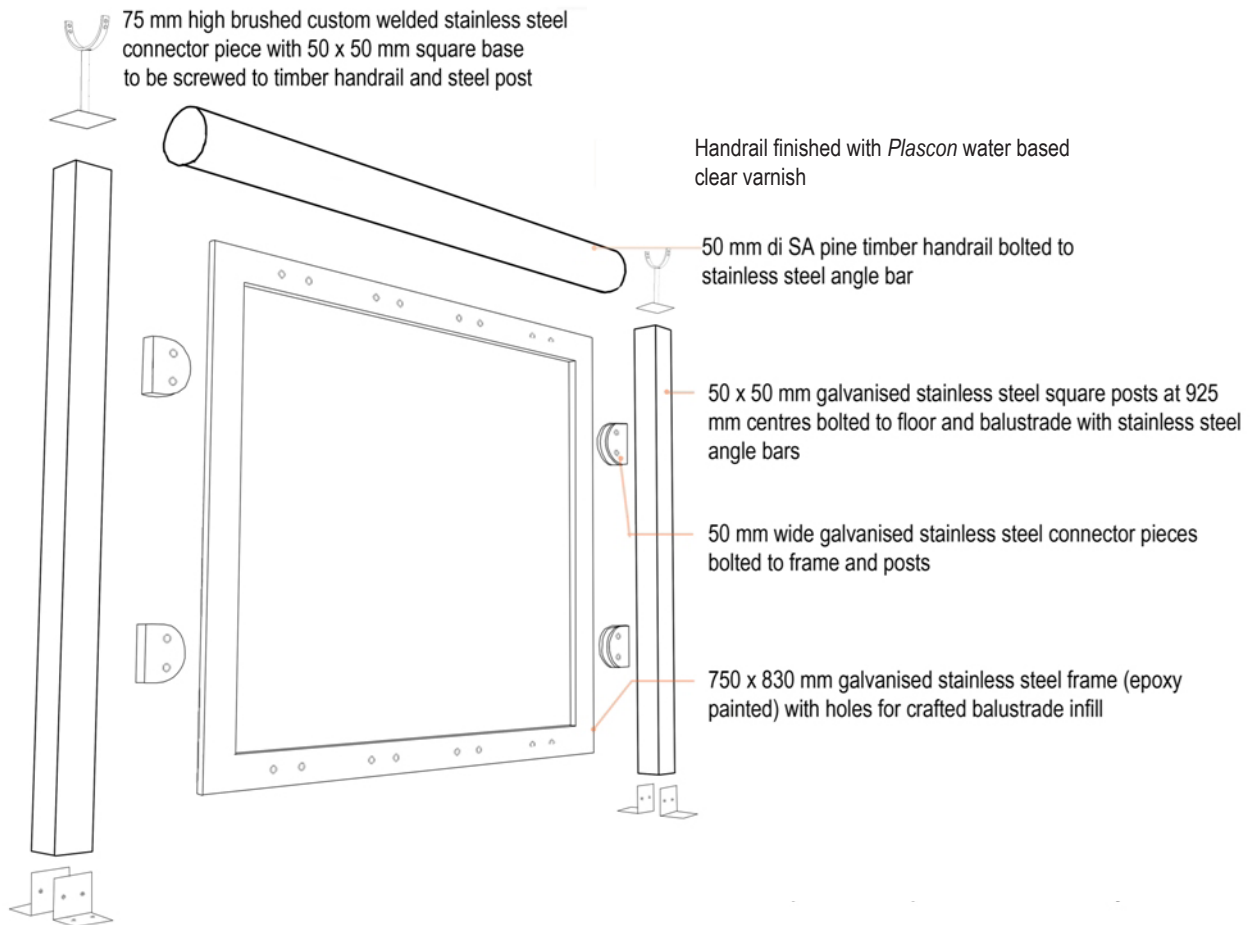

Illus 6.32 3D Explosion for Assembly (Author, 2011)

6.7.5 Detail 5: Seating: Waiting Areas, Lounges

The “historical ideal” of the boardroom furniture (Illus 6.33) has influenced the design of the linear, rectangular legs and back rest (Illus 6.34, Illus 6.35, Illus 6.38, Illus 6.39), as well as the material choice of SA Pine in this seating unit. The inspiration of colourful textiles and the craft of weaving gave rise to the decision to allow textile scrap infill to soften and liven up the furniture, while adding the crafter’s touch. The melamine impregnated paper finish on the *Formica* surface, with the POPUP log print, also assists in softening and brightening up the seating unit. The modular seating unit was derived in shape from the hexagon (Illus 6.36). A number of configurations are possible for use in social areas, as a linear bench or as a two sided seating unit ideal for a wide corridor (Illus 6.37).

25 x 25 x 250 and 25 x 25 x 400 mm SA pine battens to be joined using mortise and tenon junction (Illus 6.46)

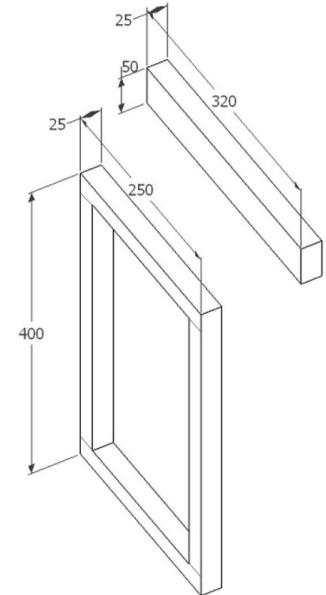

Illus 6.34 Isometric of Leg and Beam (Author, 2011)

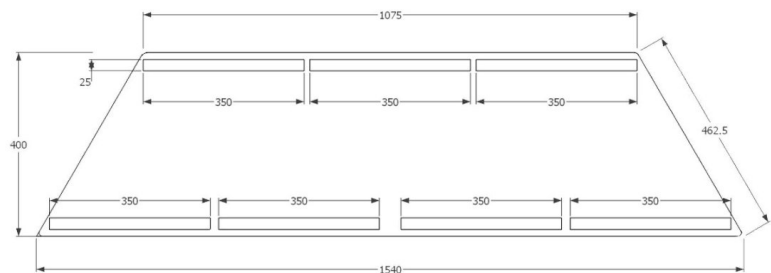

Illus 6.35 Plan of Seat (Author, 2011)

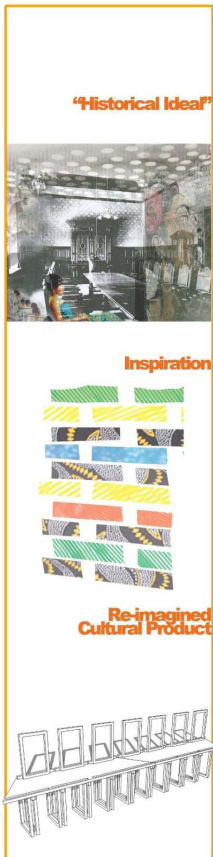

Illus 6.33 Concept and Materials (Author, 2011)

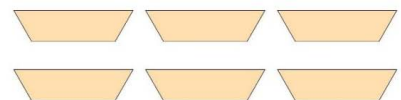
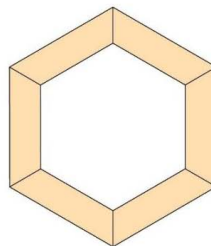
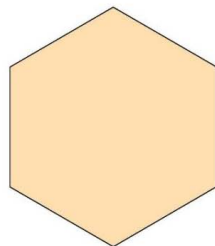

Illus 6.36 Shape Abstraction (Author, 2011)

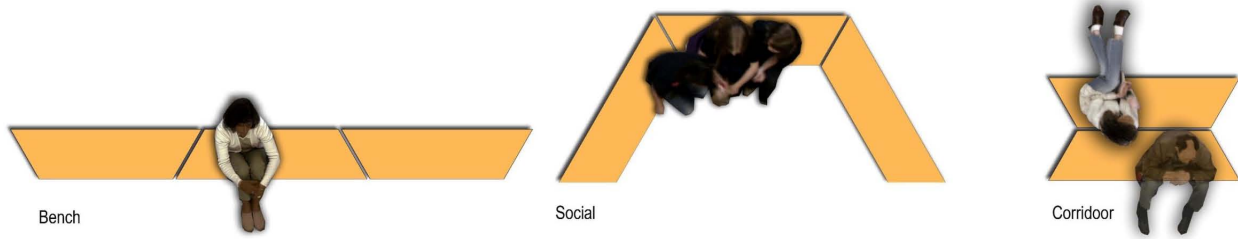

Illus 6.37 Seating Configurations (Author, 2011)

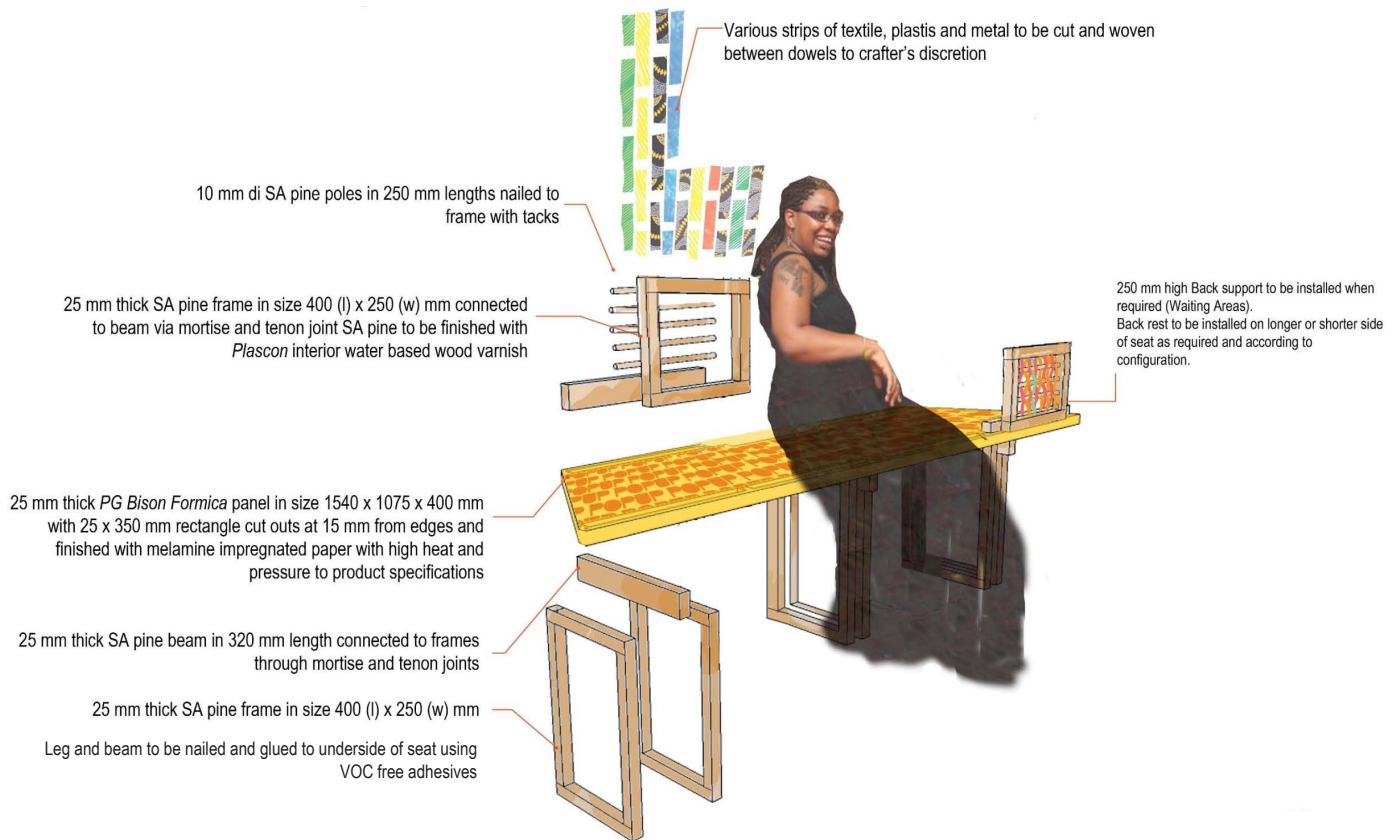

Illus 6.38 Partially Exploded 3D of Single Seating Unit (Author, 2011)

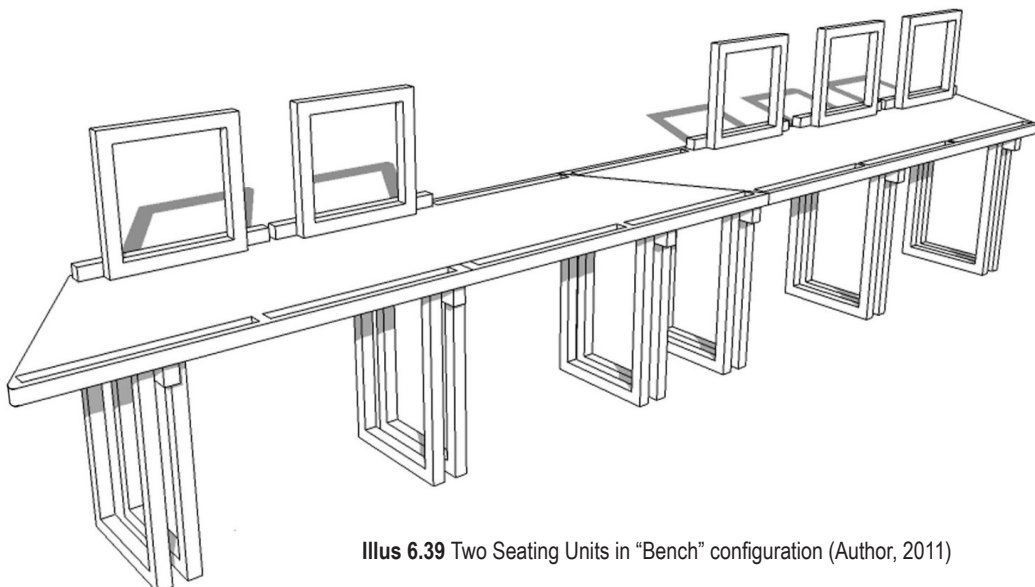

Illus 6.39 Two Seating Units in "Bench" configuration (Author, 2011)



Illus 6.41 Perspective of Dining Hall with Tables (Author, 2011)

6.7.6 Detail 6: Tables: Dining Hall, Studios, Offices

This modular sized table unit refers to the profile of the boardroom chairs depicted in the mood board and reinterprets this as a simple, altered square which sits on its frame and exposes the top of its legs (Illus 6.40, Illus 6.42). The use of SA Pine also refers to the “historical ideal” of wooden furniture. The size 700 x 700 mm and the height of 750 mm is informed by the seating conditions outlined by Neufert and demonstrated in Illus 5.27 (1999:16).

The mortise and tenon joint is demonstrated as a solution to the joining of timber pieces with more support than a conventional butt joint (Illus 6.46).

Illus 6.41 relates the table’s use to the dining hall space.

Different finish colours have been selected for various spaces in order to suit the spatial use and allow differentiation between spaces while maintaining the same furniture element throughout the building (Illus 6.43 - Illus 6.45).

25 mm thick 700 x 700 mm PG bison Formica black core board with 50 x 50 mm corner cutouts and finished with melamine impregnated paper to product specifications.

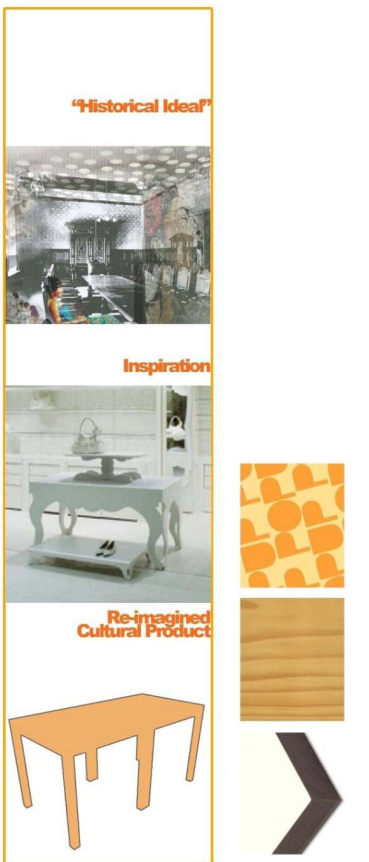

Illus 6.40 Concept and Materials (Author, 2011)

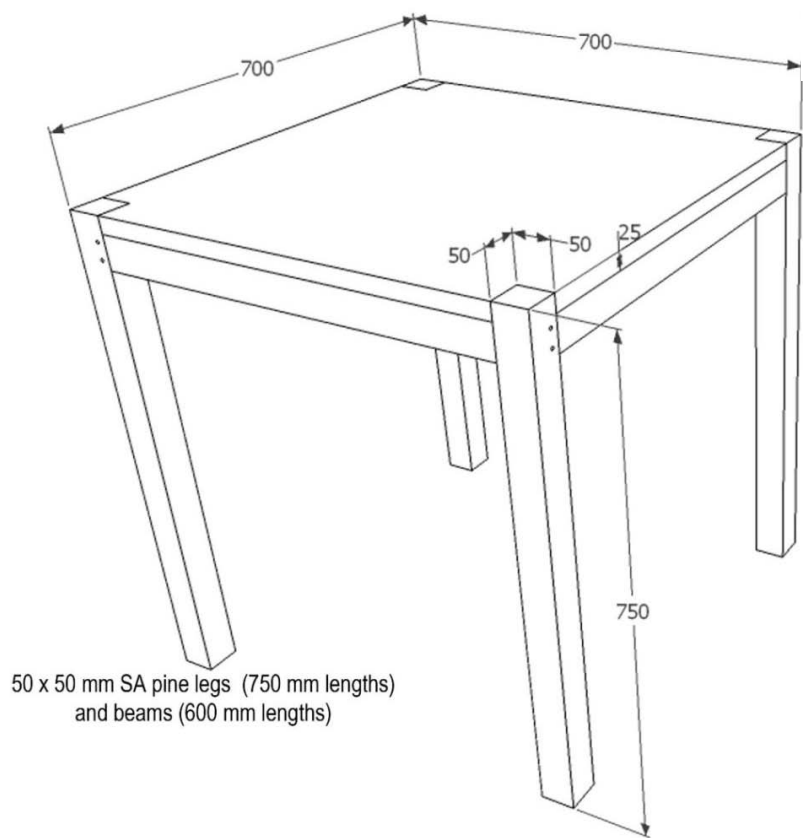

Illus 6.42 3D Detail of Table (Author, 2011)



Dining Hall Shwe Shwe print

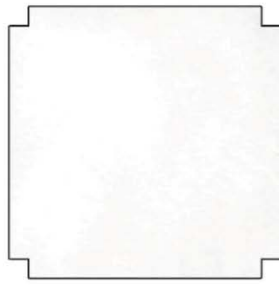

Studio (Arts and Crafts) White

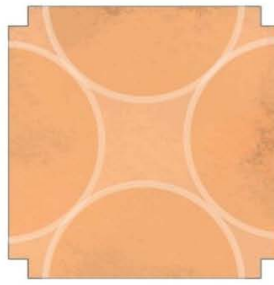

Meeting Rooms Geometric print

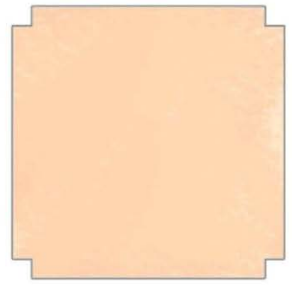

Offices Light Orange

Table Surface Finishes

25 mm thick *PG Bison Formica* board with black core to be finished with waterproof Melamine Impregnated paper using high heat and pressure as per product specifications.

Illus 6.43 Table Surface Finishes in Spaces (Author, 2011)



Dining Hall & Meeting Room Scenario:
Two 700 x 700 mm Tables

Illus 6.44 Two 700 x 700 mm Tables (Author, 2011)

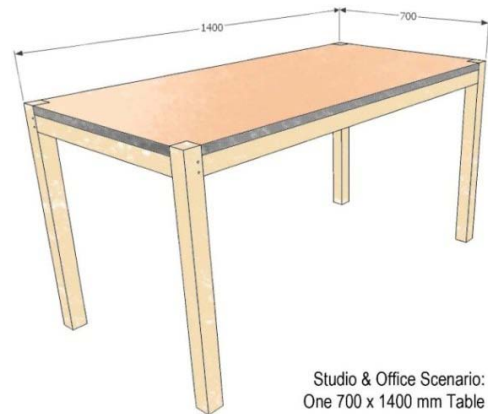

Studio & Office Scenario:
One 700 x 1400 mm Table

Illus 6.45 One 700 x 1400 mm Table (Author, 2011)

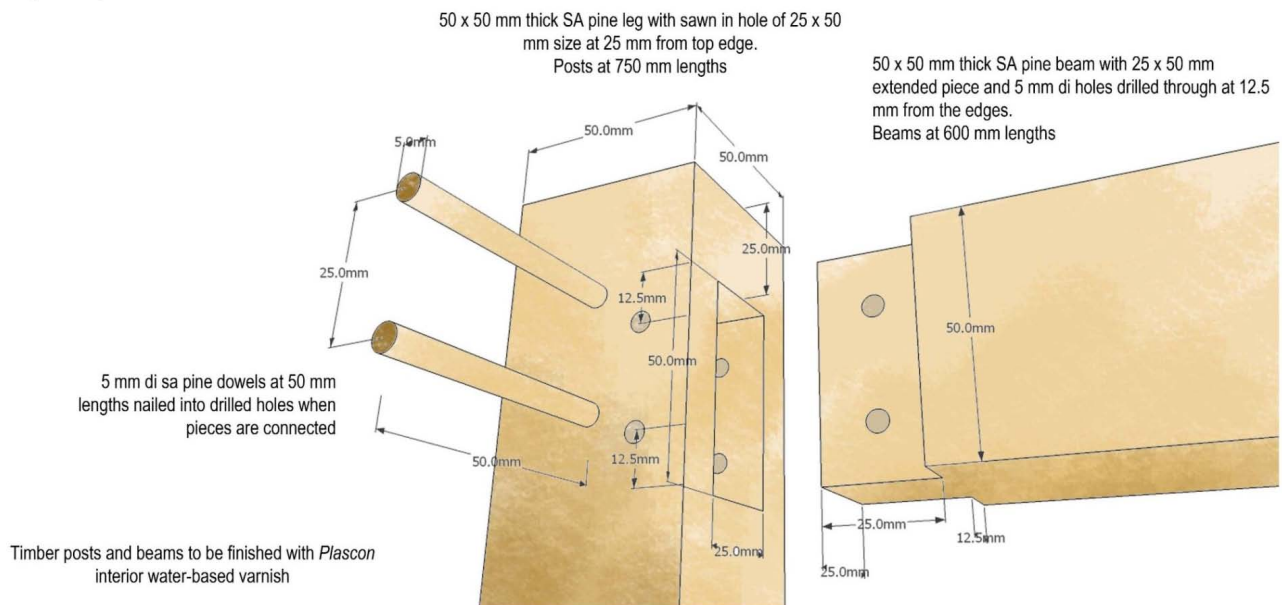

Illus 6.46 Mortise and Tenon Joint (Author, 2011)

6.7.7 Detail 7: Textile Roll Screen

This screen reinterprets the horizontal lines and flat profiles of the “historical ideal” of the boardroom furniture in the 1909 CEO, while maintaining the use of timber (SA pine) as a principal material for construction (Illus 6.47). As with detail 6, the mortise and tenon joint are utilised to join individual timber pieces in the base component (Illus 6.51). The frame (Illus 6.49) is attached to the base via nails and VOC free adhesives.

This furniture element (Illus 6.50) serves to store fabric rolls, acts as a screening device between the meeting room and studio spaces and exposes the colourful and rich variety of traditional, conventional and contemporary fabrics (Illus 6.48) as inspiration to the creative process of garment manufacture.

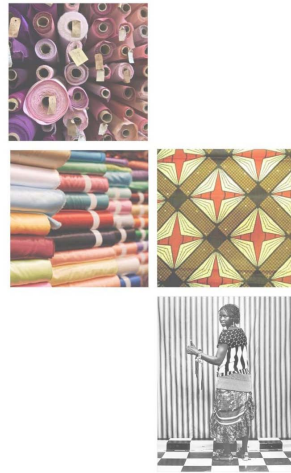

Illus 6.48 Inspiration Images (Mode de Mundo, 2010; Dan’s Upholstery, S.A. Mary, 2010)

The base element (Illus 6.51) reflects the same construction method and language evident in the construction of the support (legs and beams) of Detail 6, the table, also utilising the modular dimensions of 700 increments, with each independent base piece being 700 mm x 2100 mm in plan.



Illus 6.47 Concept and Materials (Author, 2011)

25 mm thick *PG Bison Formica* frame in 100 x 1200 x 600 mm size with 20 mm di grooves at 150 mm centres, finished with melamine impregnated paper

Frames to be nailed to base component

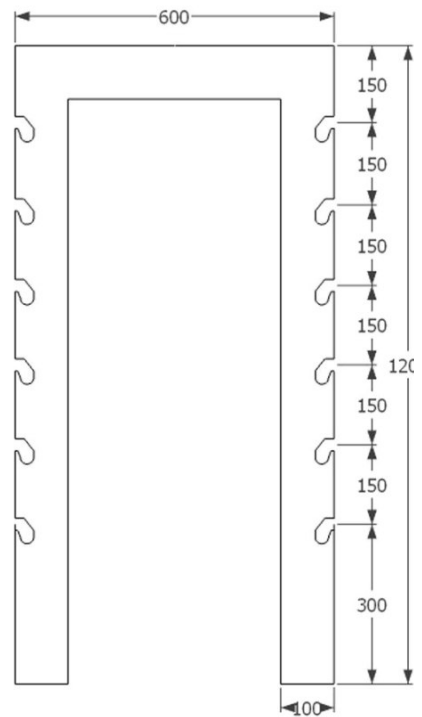

Illus 6.49 Frame Component (Author, 2011)

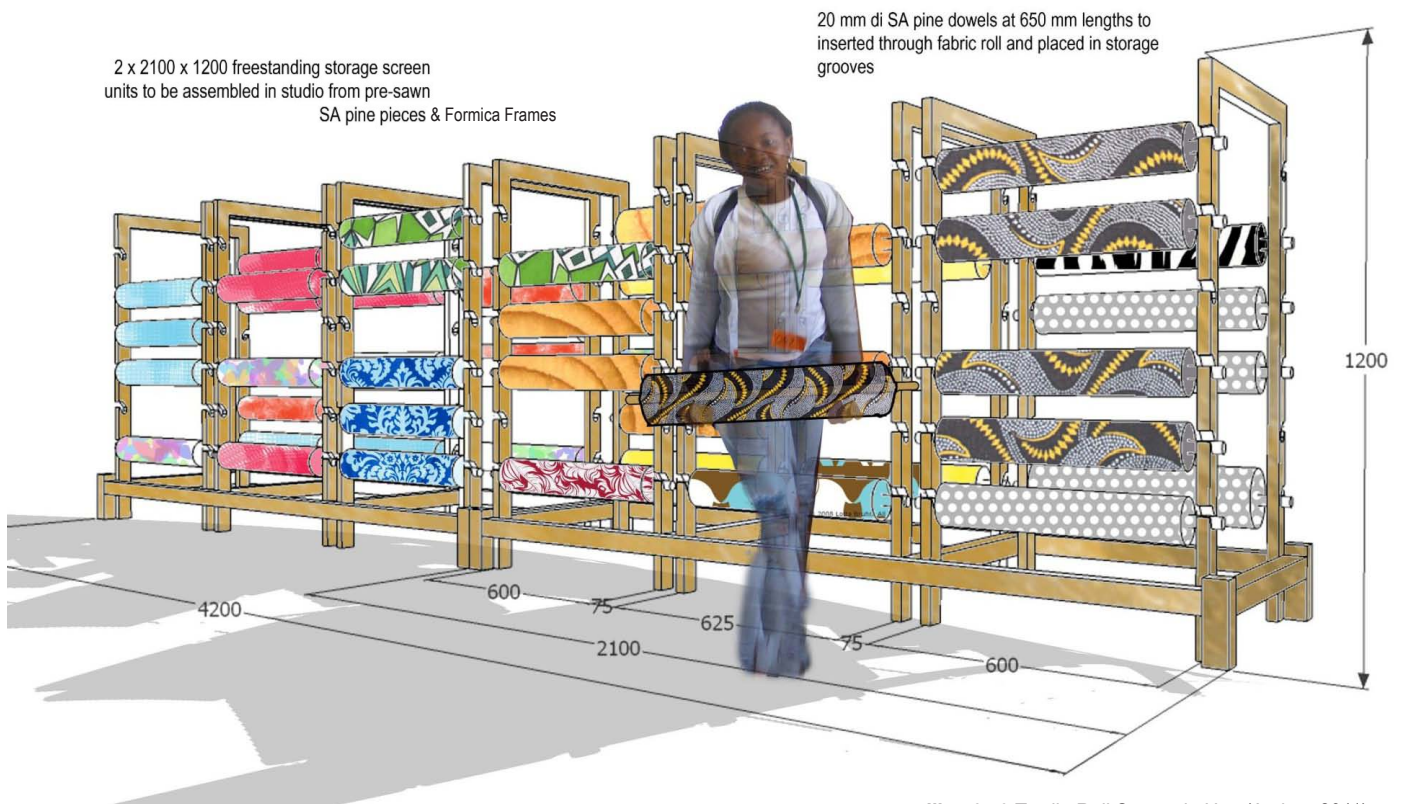

Illus 6.50 Textile Roll Screen in Use (Author, 2011)

50 x 50 mm SA pine posts and beams cut to 175 mm (post), 600 mm (beam) and 200 mm (beam) lengths and joined using mortise and tenon system.

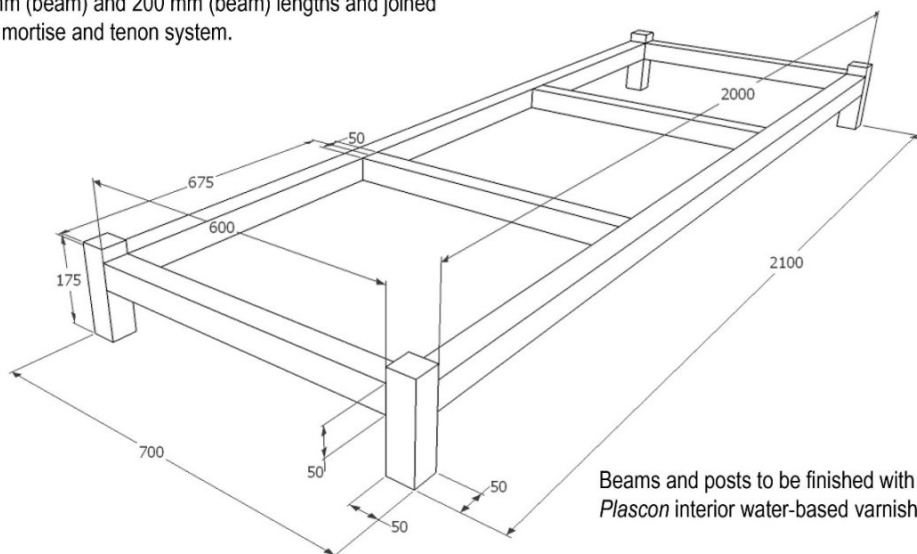

Illus 6.51 Base Component (Author, 2011)



6.8 CONCLUSION

This chapter has elaborated on the technical development of the design project.

Services, material choice, sustainability and detailing have all been explored with illustrations to supplement the explanation.

The design concept has been related to the process of detailing through the goal of reinterpreting the “historical ideal” in the design of new elements which reflect current cultural production (the activities and products related to POPUP users). These have mostly been addressed in furniture design, fixtures and finishes; elements which serve to add value to a space through creating an atmosphere which relates to the building’s historical interior, but concurrently reflects the activities, interactions and habits of its current users.



7.1 CONCLUSION

Historical architecture is static. It exists for the purpose of a time, its user and a distinct programme. If unchanged, historical architecture risks loss of occupation. Pretoria contains the situation of many historical buildings which are vulnerable to the threat of common fates of demolition, abandonment or improper alteration.

If historical architecture is to survive as a meaningful symbol to its context beyond its heritage value as “cultural property” (Feilden, 1994: 8), it demands occupation, and thereby alteration to address this.

As explored in the design study, improper alteration, as make-shift solutions, has led to the loss of value to both the existing historical building and the new programme by unsuitably addressing both or either factors. For the building to reinstate its historical integrity and address new occupation, the stripping back method (Scott, 2008:108) was proposed as a theoretical means to take the building back to its “historical ideal” and then forward by “enabling works” (Scott, 2008:108) through reflecting current cultural production.

This was achieved through the reinterpretation and re-imagination of the “historical ideal” through current cultural production. The grounded use of the creative skills training programmes as a means to inspire and involve users in product creation gave rise to a design product which is of heightened relevance to its user culture, while referring to the “historical ideal” outlined in context analysis and the mood board. This has served to contextualise relevance to the integrity of the historical, yet explicitly address current occupation, too.

The study is of benefit to the interior design discipline as it has highlighted the significance of alteration as a major field in design with focus on intervention to historical structures, with the temporal aspects of current inhabitation and cultural production being significant and key ontological aspects of the discipline.

Bibliography

BIBLIOGRAPHY

- ARCHILAB ARCHITECTS. S.a. Trade: Cape Quarter. Internet: http://www.archilab.co.za/pages/trade/projects_trade_capequarter.html (Accessed 6 June 2011)
- ASTRUP, R. 2005. Pretoria station precinct and community development centre. Pretoria: University of Pretoria. Unpublished.
- AUSTRALIA. 1999. The Burra Charter, The Australia ICOMOS Charter for Places of Cultural Significance. Australia. Internet: www.nationaltrust.com.au/burracharter.html (Accessed: 12 April 2011).
- BAKKER, K.A. 2002. Digital Folder of Salvokop photographs, history and current documentation. Unpublished.
- CANTH, J. 2011. Review for Laputa: Castle in The Sky – Double Play: The Studio Ghibli Collection. 29 April 2011. Internet: http://www.myreviewer.com/Laputa_Castle_In_The_Sky_-_Double_Play_The_Studio_Ghibli_Collection_Blu-ray_Review/a141736/page2 (Accessed 10 June 2011)
- CAPE QUARTER. [2009]. Cape Quarter History. Internet: <http://www.capequarter.co.za/history.php> (Accessed: 6 June 2011)
- CRAIG-MARTIN, M. 2000. *Towards Tate Modern*. 12 - 23. In Blazwick, I and Wilson, S. 2000. Tate Modern the handbook. London: Tate Gallery Publishing.
- COHN, D. 2006. *Rehabilitation of Santa Caterina Market, Barcelona, Spain*. Architectural Record; February 2006. Vol. 194 Issue 2, p. 98 – 105.
- DE WILD, F. 2008. *On a Mission*. Frame Magazine. Nov/Dec 2008. Issue 65, p. 178 - 181.
- DE WILD2, F. 2008. *Mi Kasa, Su Kasa*. Frame Magazine. Sept/ Oct 2008. Issue 64, p.53.
- DI MONTE, G, GLOEK, K.R., KHAN, Z and TEESEN, M (Salvokop Group). 2011. Framework Analysis and Images. Unpublished.
- DI MONTE, G. EXAMINATION PHOTOGRAPHS. 2011. Unpublished.
- EVAC+CHAIR, 2004. EVAC+CHAIR. Internet: www.evac-chair.co.za (Accessed 11 October 2011)
- DAN'S UPHOLSTERY, S.A. Dan's Upholstery. Internet: <http://www.dansupholstery.com/FabricsNew.html> (Accessed 11 October 2011)
- DOUGLAS, M. 1996. Thought Styles: critical essays on good taste. London: SAGE Publications.
- FEILDEN, B.M. 1994. Conservation of Historical Architecture. Oxford: Butterworth Heinemann.

- FLOORING DEPOT, S.A. Bamboo Engineered Floors. Internet: http://www.flooringdepot.co.za/index.php/Bamboo-/Bamboo-Suede/flypage_new_measure.html (Accessed 27 September 2011)
- FLOORWORX, S.A. Sheet Vinyl Product. Internet: http://www.floorworx.co.za/product.php?action=show_prod&id=8&cat=93 (Accessed 26 September, 2011)
- FREEDOM PARK. S.a. Freedom Park. Internet: www.freedompark.co.za (Accessed: 10 October 2010)
- GLASSTILE, S.A. Glass Mosaic Tiles. Internet: <http://glasstile.co.za/products/colours/> (Accessed 26 September 2011)
- GOOGLE EARTH, 2011. Aerial Photograph, Salvokop, Pretoria.
- GROAT, G. and Wang, D. 2002. Architectural Research Methods. New York: John Wiley and Sons.
- HUDLER, C. 2010. These are movies you don't have to like. 21 January 2010. Internet: http://blog.colinhudler.com/?attachment_id=189 (Accessed 11 June 2011)
- IHEARTGUM, 2009. MoMA Subway Art. Internet: <http://iheartgum.blogspot.com/2009/02/moma-subway-art.html> (Accessed 28 September 2011)
- KIMME, T. 2008. *Imagine life on the other side of the planet*. Frame Magazine. Sept/ Oct 2008. Issue 64, p.53.
- KÖNIGK, R. 2010. Interior design as architecture's 'Other'. Pretoria: University of Pretoria. Unpublished.
- MARY, S. 2010. Textiles. 10 June 2010. Internet: <http://cappuccino-girl.blogspot.com/2010/06/textiles.html> (Accessed 11 October 2011)
- MODE DE MUNDO, 2010. South Africa - The Rainbow Nation. 18 September 2010. Internet: <http://modedemundo.blogspot.com/> (Accessed 12 October 2011)
- NEUFERT, E and Neufert, P. 1999. Architects' Data Third Edition. Oxford: Blackwell Publishing.
- PELICANA, S.A. Mineral Fibre Tiles. Internet: <http://www.pelican.co.za/ceilings/amf+mineral+fibre+tiles/default.aspx> (Accessed 28 September 2011)
- PELICAN B, S.A. OWAcooustic Tiles. Internet: <http://www.pelican.co.za/ceilings/owacooustic+mineral+fibre+tiles/default.aspx> (Accessed 28 September 2011)
- PELICAN C, S.A. Vinyl Clad Tiles. Internet: <http://www.pelican.co.za/ceilings/vinyl+clad+ceiling+systems/default.aspx> (Accessed 28 September 2011)
- PEOPLE'S UPLIFTMENT PROGRAMME (POPUP). S.a. Skills Training. Internet: http://www.popup.co.za/pop_info.php?id=11 (Accessed: 23 October 2010)

- PEORIA, S.a. Explore Peoria. Internet: <http://www.explorepeoria.com/pages/peoriahistory> (Accessed 11 April 2011).
- PERRIN, J. 2002. Tate Modern. Internet: <http://www.galinsky.com/buildings/tatemodern/tateext.jpg> (Accessed 28 September 2011)
- PERSPEX, S.A. Technical Data. Internet: <http://www.perspex.co.za/Technical.aspx> (Accessed 27 September 2011)
- PG BISON B, S.A. Supawood Panels. Internet: <http://www.pgbison.co.za/panel-products/supawood.html> (Accessed 27 September 2011)
- RADIANT, S.A. Radiant Light Fittings. Internet: www.radiant.co.za (Accessed 1 October 2011)
- RICK MATHER ARCHITECTS, 2009. Barking Skills Centre. Internet: http://www.rickmather.com/project/category/barking_skills_centre#/project/category/barking_skills_centre (Accessed 10 June 2011)
- PG BISON A, S.A. Formica Solid Core. Internet: <http://www.pgbison.co.za/decorative-products/formica-solidcore.html> (Accessed 26 September, 2011)
- SAINT GOBAIN WEBER, S.A. Insulated Facade Panels. Internet: <http://www.sg-weber.de/fassade-wand/erfolgreich-planen/detailzeichnungen.html> (Accessed 26 September 2011)
- SCHAUFFER, A. 2011. *The Workhouse*. Property KwaZulu-Natal. February 2011. Issue 218, p. 25 – 26.
- SCOTT, F. 2008. On Altering Architecture. New York: Routledge.
- SMITH, R. 2006. *Tate Modern's Rightness versus MoMA's wrongs*. The New York Times. 1 November 2006. Internet: <http://www.nytimes.com/2006/11/01/arts/design/01tate.html> (Accessed 28 September 2011)
- SOUTH AFRICA. 1999. National Heritage Resources Act. Cape Town: Department of Arts and Culture. s.a. Internet: www.dac.gov.za/acts/NHRAct1999.pdf (Accessed 8 April 2011).
- SOUTH AFRICAN COUNCIL OF ARCHITECTURAL PROFESSION (SACAP). 2010. Schedule 1: Demarcation of Architectural Work Matrix. Internet: http://www.sacapsa.com/sacap/action/media/downloadFile?media_fileid=299 (Accessed: 10 October 2010)
- TAKAHASHI, M. 2008. *History in MDF*. Frame Magazine. Nov/Dec 2008. Issue 65, p. 59.
- VENKATESH, A. and MEAMBER, L.A. *Arts and aesthetics: marketing and cultural production*. Marketing Theory. March 2006. Vol. 6, Issue 1, p.11 - 39. Internet: <http://0-mtq.sagepub.com.innopac.up.ac.za/content/6/1/11.full.pdf+html> (Accessed 5 March 2011).
- WILLIS, J. 2009. LibriVox: Twenty Thousand Leagues Under The Sea by Jules Verne. 20 November 2009. Internet: <http://jules-verne-image.co.cc/category/jules-verne-steampunk> (Accessed: 9 June 2011)



Appendices

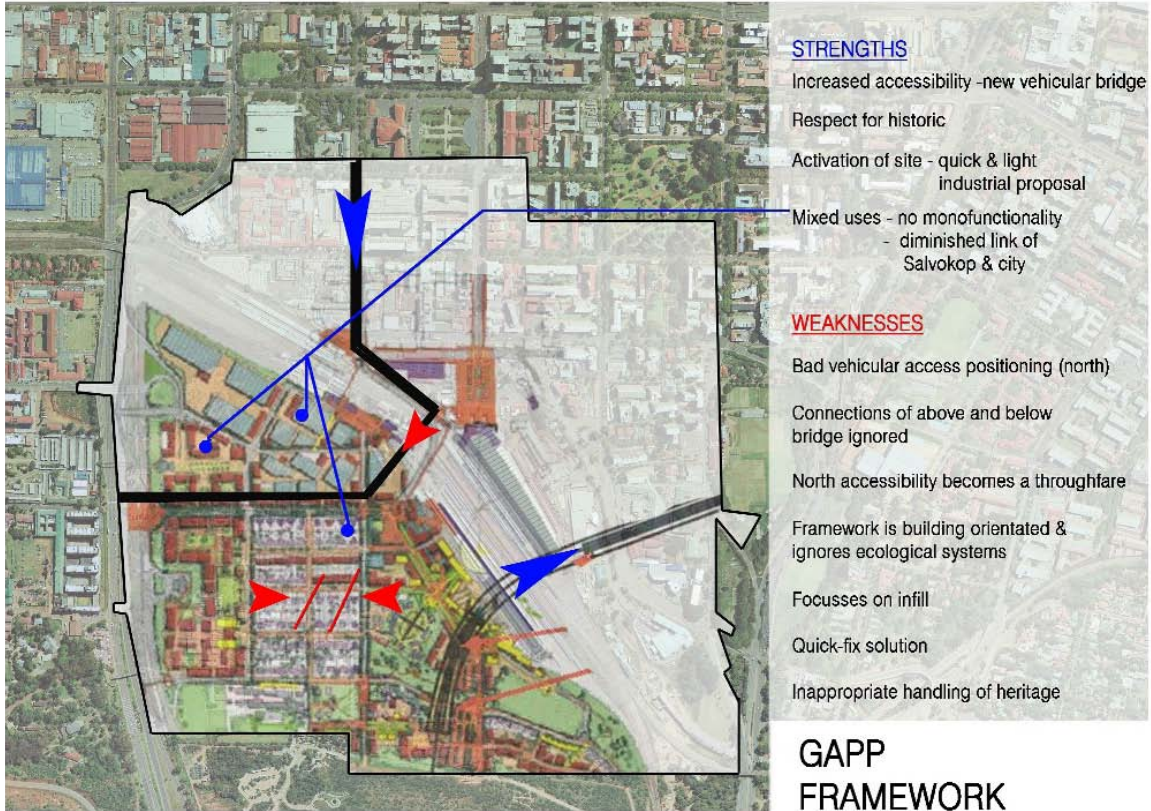

Illus 9.1 Analysis of existing GAPP Framework (Salvokop Group, 2011)

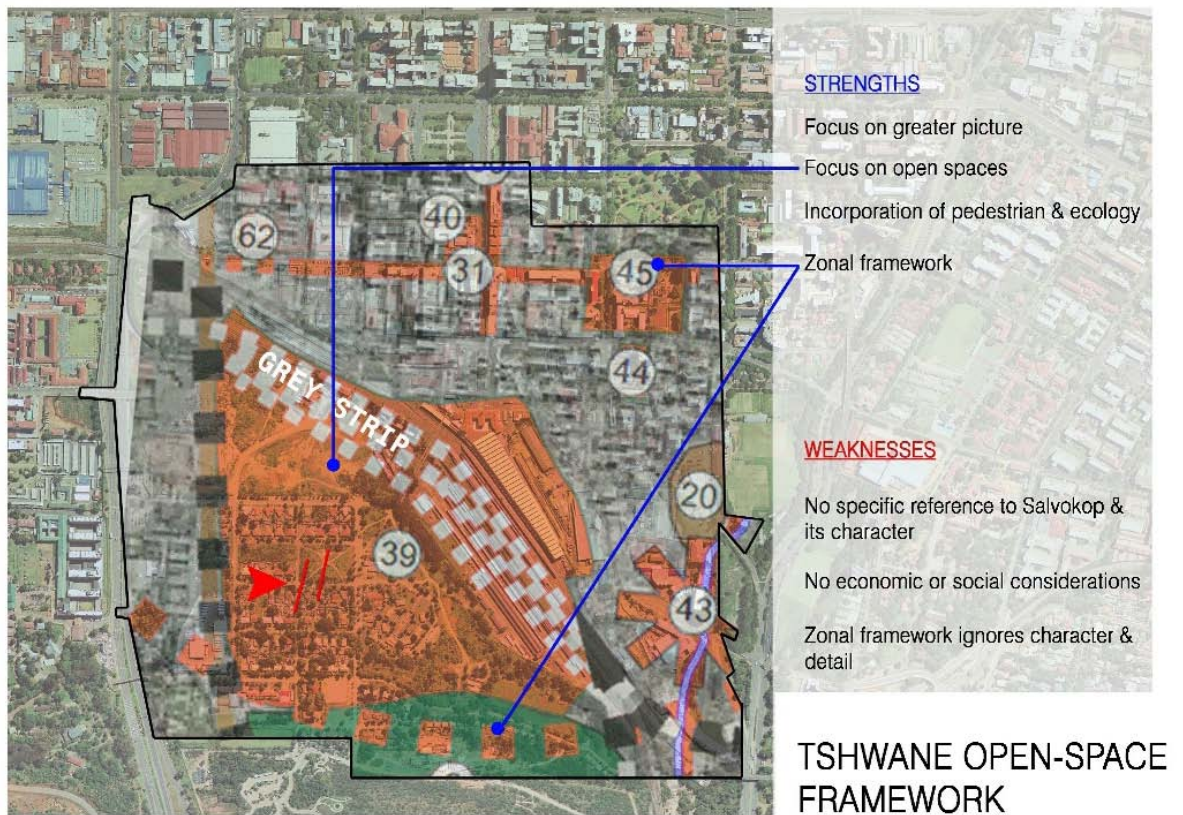

Illus 9.2 Analysis of existing Tshwane Open Space Framework (TSOP) (Salvokop Group, 2011)

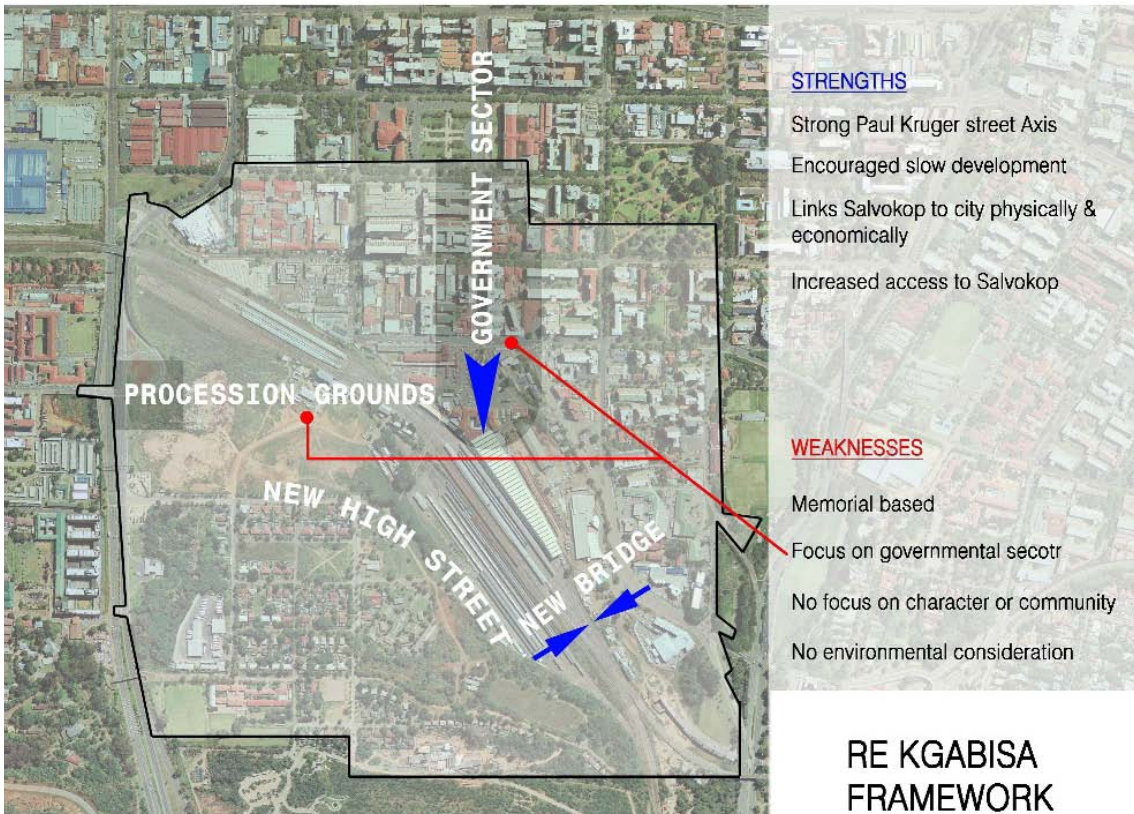

Illus 9.3 Analysis of existing Re Kgabisa Framework (Salvokop Group, 2011)



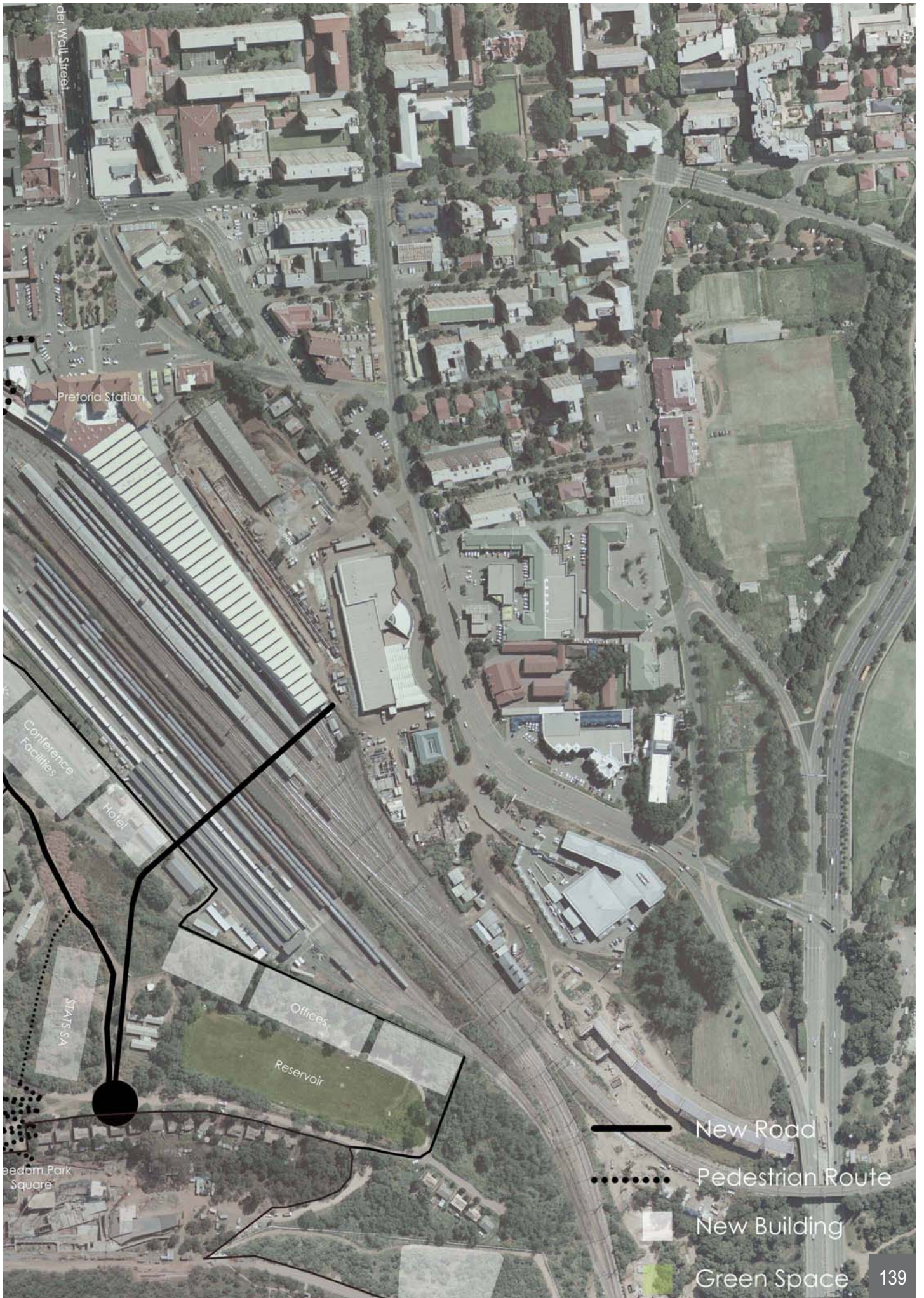



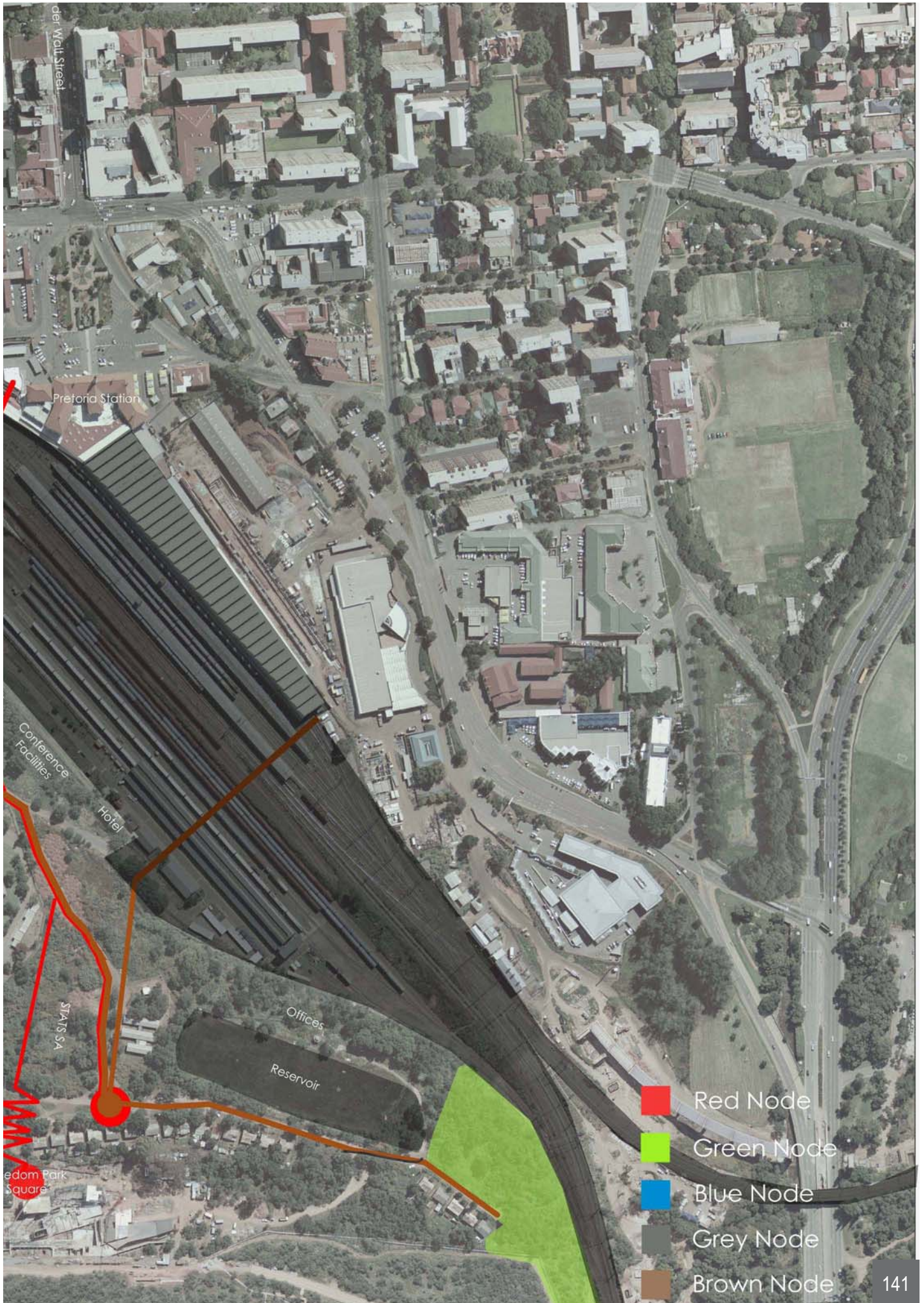



Illus 9.6 Phases 1 - 3 & All Phases Overlay (Salvokop Group, 2011)

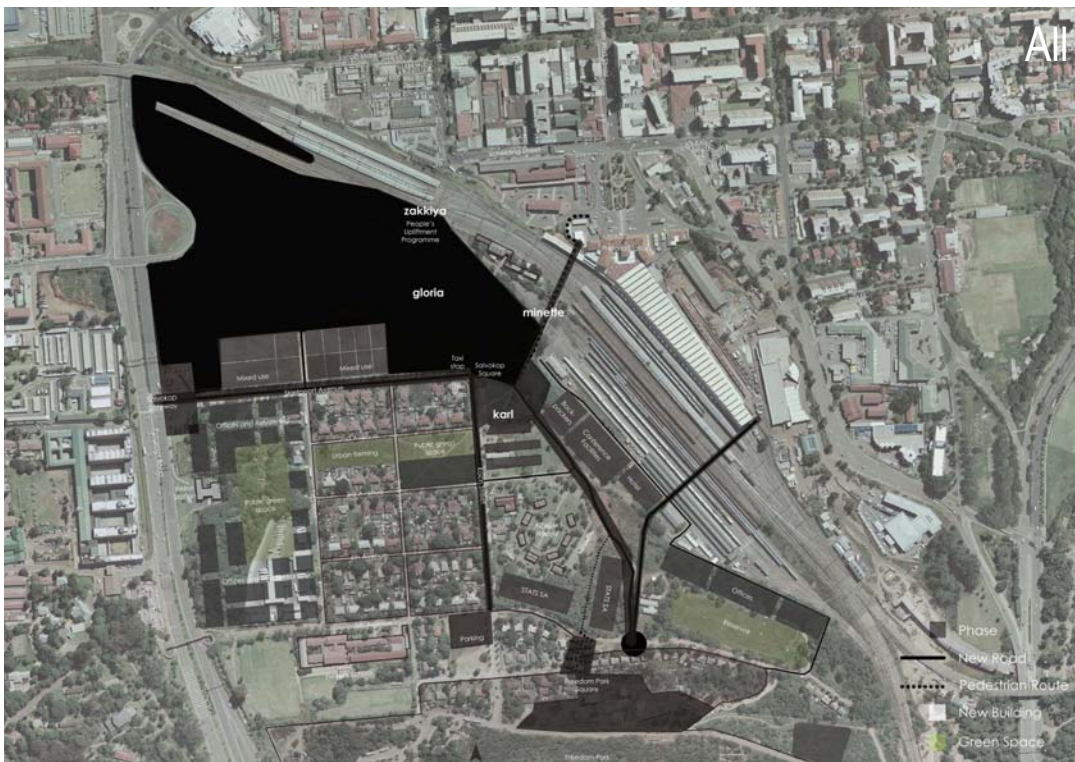

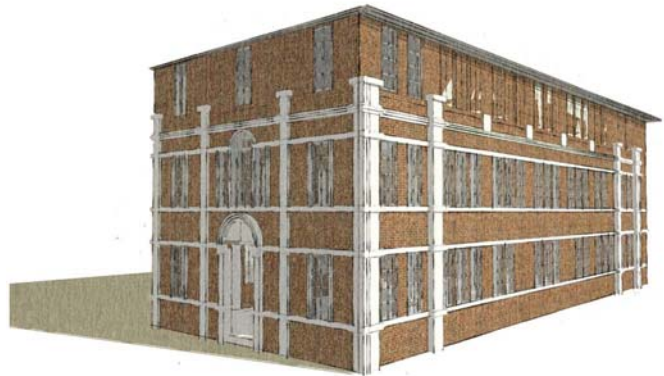

Illus 9.7 Current Condition (Author, 2011)

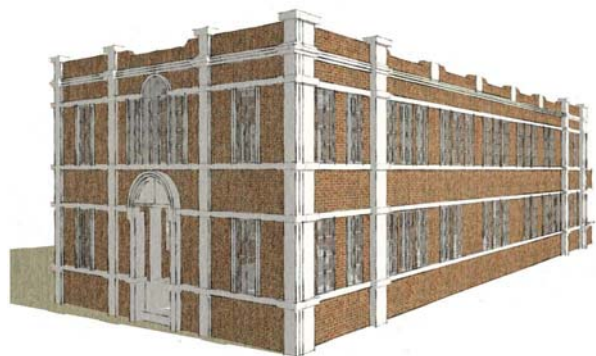

Illus 9.8 "Historical Ideal" - 1909 CEO (Author, 2011)

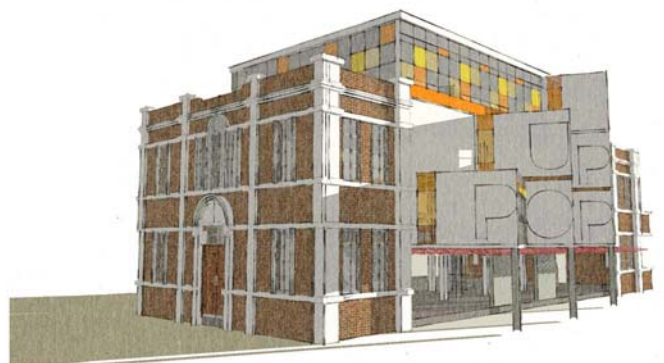

Illus 9.9 2011 POPUP (Author, 2011)



Illus 9.10 Entrance Hall (Author, 2011)



Illus 9.11 Food LAB Meeting Area / Banquet Space (Author, 2011)



Illus 9.12 Atrium and Mezzanine Spaces (Author, 2011)



Illus 9.13 The Author before design examination (Di Monte, 2011)



Illus 9.14 Sectional Structural Model (Author, 2011)

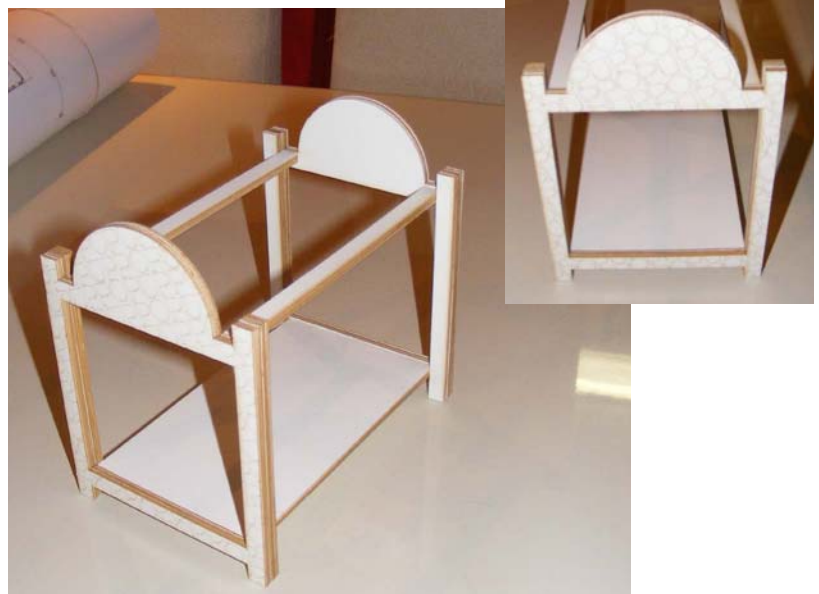

Illus 9.15 Detail 3.1 Model (Author, 2011)



Illus 9.19 Examination Presentation (Author, 2011)



Illus 9.20 Examination Presentation (Author, 2011)



Illus 9.16 The Author presenting the design project to the examination panel (Di Monte, 2011)

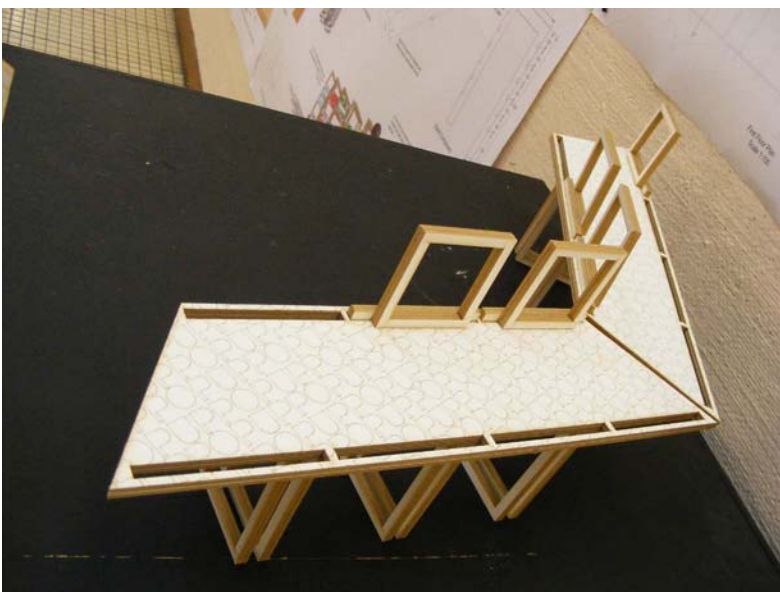

Illus 9.17 Detail 5 Model (Author, 2011)



Illus 9.18 Detail 6 Model (Author, 2011)



Illus 9.21 Design Model, Entrance View (Author, 2011)



Illus 9.22 Design Model, South Facade (Author, 2011)



Illus 9.23 Design Model, North Facade and Promenade (Author, 2011)



Illus 9.24 Design Models with presentation behind (Di Monte, 2011)



Illus 9.25 Design Model, Railway Promenade (Author, 2011)



Illus 9.26 Design Model (Author, 2011)