

Astronomical Centre at the National Zoological Gardens

J. Jordaan 26403669

Mentor : G. White

Submitted in fulfillment of part of the requirements for the degree Magister in Architecture (Professional) in the faculty of Engineering, Built environment & Information technology, University of Pretoria.





UNIVERSITEIT VAN PRETORIA
UNIVERSITY OF PRETORIA
YUNIBESITHI YA PRETORIA



You are a child of the universe, no less than the trees and flowers, and a right to be here. And whether it is clear to you, no doubt the universe is unfolding as it should. In the noisy confusion of life keep peace with your soul. With all its sham, drudgery and broken dreams, it is still a beautiful world.



Desiderata by Max Ehrman







Never before have humans known so much about the universe as we do today. Never before have we acquired new information about the universe as quickly as we do now. Yet, at the same time, never has the man been so ignorant about even the basic facts of celestial science (Lazich & Wilson, 1994 : 6). The proposed project is an Astronomical Centre in the National Zoological Gardens forecourt in the Inner City of Tswane. The facility is intended to become a vehicle of discovery of the sky, a place where humans will discover the magic and mysteries of the universe.







This project is dedicated to my brother David, my wonderful parents Fanie and Louise and to Jasper.

The topic of the dissertation was chosen as a result of my life-long fascination with the sky.



Contents

Chapter 1: The problem and its setting

1.1	The Problem Statement	1
1.2	The Project	2
1.3	The Location	3
1.4	Why a Planetarium in the Inner City of Tshwane?	4
1.5	Accommodation Schedule	8
1.6	Client Profile	9
1.7	User Profile	9

Chapter 2: Theoretical Investigation

2.1	African skies African People	12
2.2	Archetype, existential expression and shared experience	13
2.3	Geometries	14
2.4	The Floor	15
2.5	The Wall	17
2.6	The Roof	19

Chapter 3: Meso Context

3.1	The Cosmic City	21
3.1.1	Pretoria as Urbs Quadrata	22
3.2	The Tswane Inner City Development Framework	23
3.3	Analysis surround	25
3.4	Site Choice motivation	26

Chapter 4: Micro Context

4.1	Boom Street	28
4.2	Legal Determinants	30
4.3	Analysis surround	32
4.4	Conclusions and suggestions regarding context study	35

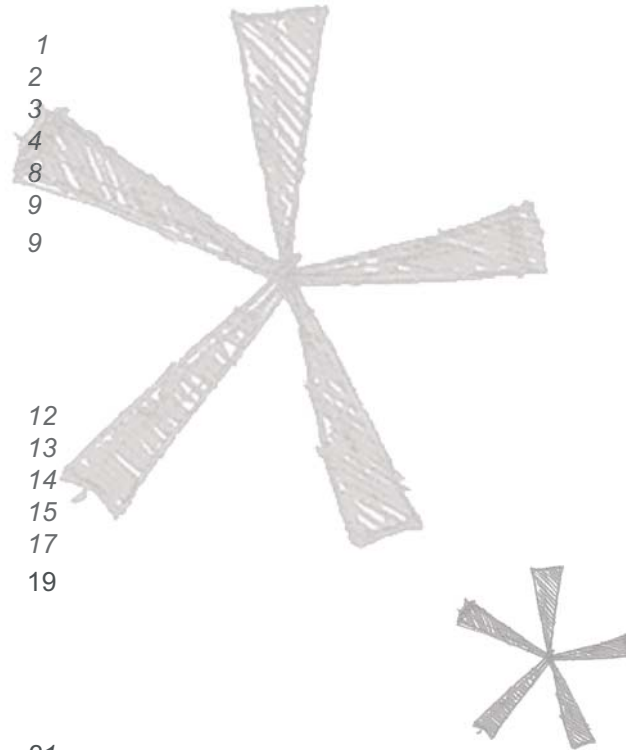

Chapter 5: Precedent Studies

5.1	Fabrica Benneton Art School, Vilorba, Treviso, Italy	37
5.2	Extension of the Reina Sofia National Museum, Madrid	39
5.3	Rose Centre for earth and space, New York	41
5.4	Origins Centre, Johannesburg	45

Chapter 6: Design Development

6.1	The process	47
6.2	The final concept	51
6.3	Design development	56

Chapter 7: Technical Investigation

7.1	Structure	60
7.2	Skin	63
7.3	Fire	64
7.4	Natural determinants	64
7.5	Orientation and solar control	65
7.6	Access	67
7.7	Services	67
7.8	The planetarium	68

Chapter 8: Drawings

8.1	Site Plan	72
8.2	Ground Floor Plan	74
8.3	First Floor Plan	73
8.4	Basement 1 Plan	75
8.5	Basement 2 Plan	76
8.6	Sections	77
8.7	Elevations	79
8.8	Details	81

Addendum :1 Baseline Study

Bibliography



List of Figures

- Figure I *Earthrise*, photograph taken by W. Anders, 1986(<http://www.nationalgeographic.com>, 0105/07)
- Figure ii *Spaceship launching* (<http://www.nationalgeographic.com>, 0105/07)
- Figure iii *The African Sky*, photograph taken by June Jordaan
- Figure 1.1.1 *The surface of the moon* (<http://www.nationalgeographic.com/>, 0105/07)
- Figure 1.1.2 *Aerial view of the Inner City of Tshwane Inner CBD*(Kruger 2006 : 1)
- Figure 1.1.3 Saturn (<http://www.nationalgeographic.com/>, 01/05/07)
- Figure 1.2.1 – 1.2.5 Images indicating the versatility of the planetarium(www.zeiss.de, 27/05/07)
- Figure 1.3.1 *The National Zoological Gardens*, photograph taken by June Jordaan
- Figure 1.3.2 *Aerial photograph of the zoo forecourt* (Aerial Photograph, Geography Department, University of Pretoria)
- Figure 1.4.1 *A view of mars* (<http://www.nationalgeographic.com>, 0105/07)
- Figure 1.4.2 *Location of Sutherland in South Africa*, drawn by June Jordaan
- Figure 1.4.3 *Locations of Planetariums in the Southern Hemisphere* drawn by Jordaan
- Figure 1.4.4 *Footprint on the moon* (<http://www.nationalgeographic.com>, 0105/07)
- Figure 1.4.5 *Neil Armstrong - Apollo 11 Moon Landing* (<http://www.nationalgeographic.com>, 0105/07)
- Figure 1.4.6 *Footprint on the moon* (<http://www.nationalgeographic.com>, 0105/07)
- Figure 1.5 *Children in the Zoo*, photograph taken by René van der Linde
- Figure 2.1.1 *Fire on Marlborough Street*, photograph taken by S.J. Forman (<http://www.time.com>, 0105/07)
- Figure 2.1.2 *Sorrow*, photograph taken by H. Cooke(Thijs-Evensen, 1987:16)
- Figure 2.1.3 *Great Zimbabwe* (<http://www.mc.maricopa.edu>, 02/08/07)
- Figure 2.1.4 *City lights* (www.manchesteronline.co.uk, 02/08/07)
- Figure 2.1.5 *Stars of the city* (<http://ahmadshahied.fotopages.com>, 02/08/07)
- Figure 2.2.1 *Man in motion*, photograph taken by G. Mili(Thijs-Evensen, 1987:26)
- Figure 2.2.2 *Man and substance*, photograph by W. Bullock(Thijs-Evensen, 1987:28)
- Figure 2.3.1 *Nahoshima Contemporary Art Museum, Tadao Ando* (Ando 1988 : 25)
- Figure 2.3.2 *Geometries*, drawn by author
- Figure 2.3.3 *Maupertius*, Project of an Agricultural Lodge, 1775, Claude-Nicolas Ledoux(Ching, 1996: 42)
- Figure 2.3.4 Roof plan of astronomy centre, drawn by author
- Figure 2.4 *The experiential nature of the floor* (Thijs-Evensen, 1987:34)
- Figure 2.4.1 *The parts of nature's floor* (Thijs-Evensen, 1987:37)
- Figure 2.4.2 *The expression of nature's floor* (Thijs-Evensen, 1987:40)
- Figure 2.4.3 *The attached floor* (Thijs-Evensen, 1987:51)
- Figure 2.4.4 *The open floor* (Thijs-Evensen, 1987:63)
- Figure 2.4.5 *The mirror floor* (Thijs-Evensen, 1987:65)
- Figure 2.4.6 *The detached floor* (Thijs-Evensen, 1987:57)
- Figure 2.4.7 *The sunken floor* (Thijs-Evensen, 1987:75)
- Figure 2.5 *The experiential nature of the wall*(Thijs-Evensen, 1987:114)

- Figure 2.5.1 *The main forms of the wall (Thijs-Evensen, 1987:142)*
- Figure 2.5.2 *The horizontal wall, drawn by June Jordaan*
- Figure 2.5.3 *The vertical wall, drawn by June Jordaan*
- Figure 2.6 *The experiential nature of the Roof(Thijs-Evensen, 1987:298)*
- Figure 2.6.1 *The roof and its relationship to the sky above (Thijs-Evensen, 1987:301)*
- Figure 2.6.2 *Flat roof and the articulated transition between ceiling and wall (Thijs-Evensen, 1987:301)*
- Figure 2.6.3 *Perspective of the astronomy centre indicating the roofs, drawn by June Jordaan*
- Figure 3 *The Milky way, digital collage by June Jordaan(photograph - <http://www.nationalgeographic.com>, 0105/07)*
- Figure 3.1.1 – 3.1.6 *Pretoria as Urbs Quadrata (Jordaan 1989 : 27)*
- Figure 3.1.7 *The Continents, drawn by June Jordaan*
- Figure 3.1.8 *Metro map of Tshwane, drawn by June Jordaan*
- Figure 3.1.9 *Location of Tshwane, drawn by June Jordaan*
- Figure 3.2.1 *Figure ground of the Tshwane CBD, drawn by June Jordaan*
- Figure 3.2.2 *Public space network (Kruger 2006 : 1)*
- Figure 3.2.3 *Core axis (ibid)*
- Figure 3.2.4 *Announce the arrival (ibid)*
- Figure 3.2.5 *The seven precincts (ibid)*
- Figure 3.2.6 *Accentuate green space and public elements (ibid)*
- Figure 3.3.1 *Perspective of the CBD of Tshwane, drawn by June Jordaan*
- Figures 3.3.2 – 3.3.4 *Photographs taken in the zoo by June Jordaan*
- Figure 4 *The Hubble Telescope (<http://www.focks.com>, 0105/07)*
- Figure 4.1.1 *Perspective indicating Boom Street, drawn by June Jordaan*
- Figure 4.1.2 *Images of the Boom Street Paul Kruger Street crossing facing north(Group 3 Urban Analysis, 2007)*
- Figure 4.1.3 *Figure ground of Boom Street indicating location of zoo forecourt, drawn by June Jordaan*
- Figure 4.1.4 *Images of the Boom Street Paul Kruger Street crossing facing west(Group 3 Urban Analysis, 2007)*
- Figure 4.1.5 *Section through Boom Street (ibid)*
- Figure 4.1.6 *Image indicating section, digital collage done by June Jordaan (Aerial Photograph, Geography Department, University of Pretoria)*
- Figure 4.2.1 *Figure ground of the Tshwane CBD indicating site, drawn by June Jordaan*
- Figure 4.2.2 *Images of the Boom Street Paul Kruger Street crossing facing east (Group 3 Urban Analysis, 2007)*
- Figure 4.3.1 *The Historical Z.A.R Museum today, photograph taken by June Jordaan*
- Figure 4.3.2 *Section through Boom Street(Group 3 Urban Analysis, 2007)*
- Figure 4.3.3 *Image indicating section, digital collage done by June Jordaan (Aerial Photograph, Geography Department, University of Pretoria)*
- Figure 4.3.4 *The Historical Z.A.R Museum (Le Roux 1991 :28)*
- Figure 4.3.5 *Perspective indicating the existing buildings in the northern gateway, drawn by June Jordaan*
- Figure 4.3.6 *The corner cafe(Group 3 Urban Analysis, 2007)*
- Figure 4.3.7 *The residential heritage building(ibid)*

- Figure 4.3.8 *The flat block*(ibid)
- Figure 4.3.9 *The zoo forecourt*, photograph taken by June Jordaan
- Figure 4.3.10 Aquarium and Reptile Park (Aerial Photograph, Geography Department, University of Pretoria)
- Figure 4.3.11 *Zoo map*, scanned from zoo pamphlet 12/042007
- Figure 4.3.12 *Zoo circulation map* (Kitshof 2007)
- Figure 4.3.13 *Western façade of the museum*, photograph taken by June Jordaan
- Figure 4.4.1 *Perspective indicating Boom Street*, drawn by June Jordaan
- Figure 4.4.2 *Perspective of the proposed northern gateway*, drawn by June Jordaan
- Figure 5 *R. Buckminster Fuller* (McHale 1962:65)
- Figures 5.1.1 & 5.1.5 *Sections* (Diverse, 2000:90)
- Figures 5.1.2 & 5.1.3 *Fabrica Benneton Art School, Vilorba, Triviso*(Diverse, 2000:90)
- Figure 5.1.4 *Model of Fabrica Benneton Art School, Vilorba*(Futogawa 1993)
- Figure 5.2.1 *Street elevation of the extension of the Reina Sofia National Museum* (Carbonero 2001 : 80)
- Figure 5.2.2 *Internal view of the extension of the Reina Sofia National Museum* (ibid)
- Figure 5.2.3 *Internal view of the extension of the Reina Sofia National Museum* (Carbonero 2001 : 80)
- Figure 5.2.4 *Section through the extension of the Reina Sofia National Museum* (Carbonero 2001 : 83)
- Figure 5.2.5 *Section through the extension of the Reina Sofia National Museum* (ibid)
- Figure 5.2.6 *Plan of the extension of the Reina Sofia National Museum* (ibid)
- Figure 5.2.7 *Internal view of the extension of the Reina Sofia National Museum* (Carbonero 2001 : 84)
- Figure 5.3.1 *Street elevation of the Rose Center for Earth and Space* (<http://www.amnh.org/rose> 07/09/07)
- Figure 5.3.2 *Inside the Rose Centre for Earth and Space* (<http://www.amnh.org/rose> 07/09/07)
- Figures 5.3.3 & 5.3.4 *Sections* (Pearson 2001 : 104)
- Figures 5.3.5 – 5.3.7 *Plans* (Pearson 2001 : 104)
- Figure 5.3.8 *Inside the Rose Centre for Earth and Space* (<http://www.amnh.org/rose> 07/09/07)
- Figure 5.3.9 *Jupiter* (<http://photography.nationalgeographic.com/photography/index.html>, 08/09/07)
- Figure 5.4.1 *Interior view of the Origins Centre* (www.mashabanerose.co.za/team.htm 09/10/07)
- Figures 5.4.2-5.4.9 *Exhibition space in the Origins Centre*, photographs taken by June Jordaan
- Figures 5.4.10-5.4.11 *Plans of the Origins Centre*, scanned from pamphlet 23/06/07
- Figure 5.4.12 *The surface of the moon* (<http://www.nationalgeographic.com/>, 01/05/07)
- Figure 6 *The geodesic dome* (McHale 1962:102)
- Figures 6.1.1 – 6.1.7 *Design development diagrams*, drawn by June Jordaan & Rene van der Linde
- Figure 6.1.8 *Perspective of proposed northern gateway*, drawn by June Jordaan
- Figures 6.1.9 - 6.1.13 *Concept models*, photographs taken by June Jordaan
- Figures 6.1.14 & 6.1.15 *Movement diagrams*, drawn by June Jordaan
- Figure 6.1.8 *Concept Sketch*, drawn by June Jordaan
- Figures 6.2.1 – 6.2.5 *Final concept sketches*, drawn by June Jordaan
- Figure 6.2.6 *The solar system in orbit* (<http://www.wikipedia.com/thesolarsystem.htm> 27/02/07)
- Figures 6.2.7 – 6.2.12 *Sonic Architecture* (<http://www.sonicarchitecture.com.htm> 05/03/07)

- Figure 6.2.13 *Timeline of the universe* (<http://www.ieec.fcr.es> 09/10/07)
- Figure 6.2.14 *Star stop diagram*, drawn by June Jordaan
- Figure 6.2.15 *Solar system scale walkway, digital collage* by June Jordaan (Aerial Photograph, Geography Department, University of Pretoria)
- Figures 6.3.1 – 6.3.10 *Design development*, drawn by June Jordaan
- Figure 6.3.11 *Perspective of astronomy centre*, drawn by June Jordaan
- Figure 7 *Construction of a geodesic dome*(McHale 1962:50)
- Figure 7.1.1 -7.1.9 *Phases of the construction of the sphere*, drawn by June Jordaan
- Figure 7.2.1 & 7.2.2 *Perspectives of the astronomy centre*, drawn by June Jordaan
- Figure 7.2.3 *Concrete* (<http://www.propro.ru>)
- Figure 7.2.4 *Glass* (<http://www.arcspace.com>09/10/07)
- Figure 7.2.5 *Copper* (<http://www.whimsie.com/coppersheet.jpg> 09/10/07)
- Figure 7.2.6 *Facebrick* (<http://www.brickandstonefloors.com> 09/10/07)
- Figure 7.2.7 *Litracon* (<http://www.litracon.hu/projects.php> 09/10/07)
- Figure 7.3.1 *Fire diagram*, drawn by June Jordaan
- Figure 7.3.2 *Contour map*, drawn by June Jordaan
- Figure 7.3.3 *Drawing indicating sun angles and slope of site*, drawn by June Jordaan
- Figure 7.5.1 *Perspective of astronomy centre*, drawn by June Jordaan
- Figure 7.5.2 *Orientation diagram*, drawn by June Jordaan
- Figure 7.5.3 *Timber sunscreen*(Architecture SA Jan/Feb 2007 cover page)
- Figure 7.5.4 *Vertical louvers* (Architect's Journal 2007: 27)
- Figures 7.5.5 & 7.5.6 *Vertical louvres* (Architect's Journal 2007: 28)
- Figures 7.5.7 - 7.5.12 *Vertical louvre details* (<http://www.duco.eu> 15/08/07)
- Figure 7.5.13 *Star stop diagram*, drawn by June Jordaan
- Figure 7.5.14 *Calculation of star stops in temporary exhibition space*, drawn by June Jordaan
- Figure 7.6.1 *Detail of stair lift for wheelchairs* (Adler 2000 :8)
- Figures 7.7.1 & 7.7.2 *Working diagrams*, drawn by June Jordaan
- Figure 7.7.3 *Skymaster SKP 4* (www.zeiss.de 04/04/07)
- Figure 7.8.1 *Working diagram of auditorium*, drawn by June Jordaan
- Figure 7.8.2 *Auditorium plan indicating seating arrangement*, drawn by June Jordaan
- Figure 7.8.3 *Seating arrangements* (www.zeiss.de 04/04/07)
- Figure 7.8.4 *Universarium* (www.zeiss.de 04/04/07)
- Figure 8.1.1 - 8.8.20 *Technical documentation drawings of the astronomy centre*, drawn by June Jordaan
- Figure 9 *The African Sky*, photograph taken by Jasper Blokland
- Figure 9.1 *View of the sun from Jupiter* (<http://www.nationalgeographic.com>, 0105/07)
- Figure 9.2 *Footprint on the moon* (<http://www.nationalgeographic.com>, 0105/07)
- Figure 9.3 *Indication of performance of design in terms of sustainability*(Gibbert 2004)

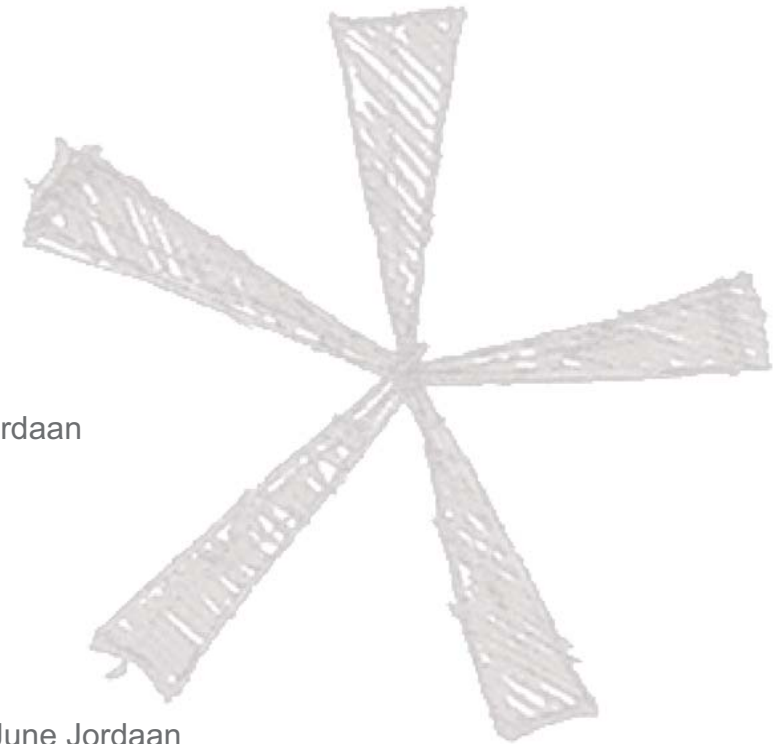



The Problem and its setting

Figure 1.1.2 The Inner City of Tswane



Introduction

The City of Tshwane is the birthplace of the new South African democracy. It is the place where past and future met on the steps of the Union Buildings and the place where the first democratically elected president was inaugurated. On that day the capital city of democracy was born (Kruger 2006: 11).

The Inner City of Tshwane is a place of strategic significance, not only in the city but also from a national and international perspective (ibid). As the seat of national government, Tshwane has the responsibility to set high standards for leadership and has the potential to develop as the capital city of a newly united African continent (ibid). In addition, Tshwane is recognised as the educational capital of Africa, being home to numerous well recognised institutions.

The goal of this chapter is to identify the problem and the setting of the problem in the Inner city of Tshwane that will be dealt with in dissertation.

1.1 The Problem Statement

The vision of Tshwane is to become the leading international African Capital City of Excellence that empowers the community to prosper in a healthy and safe environment (Kruger 2006: 5). The current quality of the inner city, however, does not support this vision because it is not functioning as it should, from an environmental, economic and social point of view (Kruger 2006: 14).

In order to address this problem the author considered a government strategy known as the *Tshwane Inner City Development and Regeneration Strategy* (Kruger 2006). This strategy is based on a catalytic-intervention approach. Strategic interventions are proposed to significantly influence the development of the inner city. The strategy identifies a number of aspects that should be dealt with in order to sustain urban renewal. Amongst other issues, the strategy identifies the importance of the inner city to provide tourism, recreational and entertainment opportunities for both the Tshwane residents and tourists (Kruger 2006: 14). The dissertation focuses on the development of one such project in the inner city.

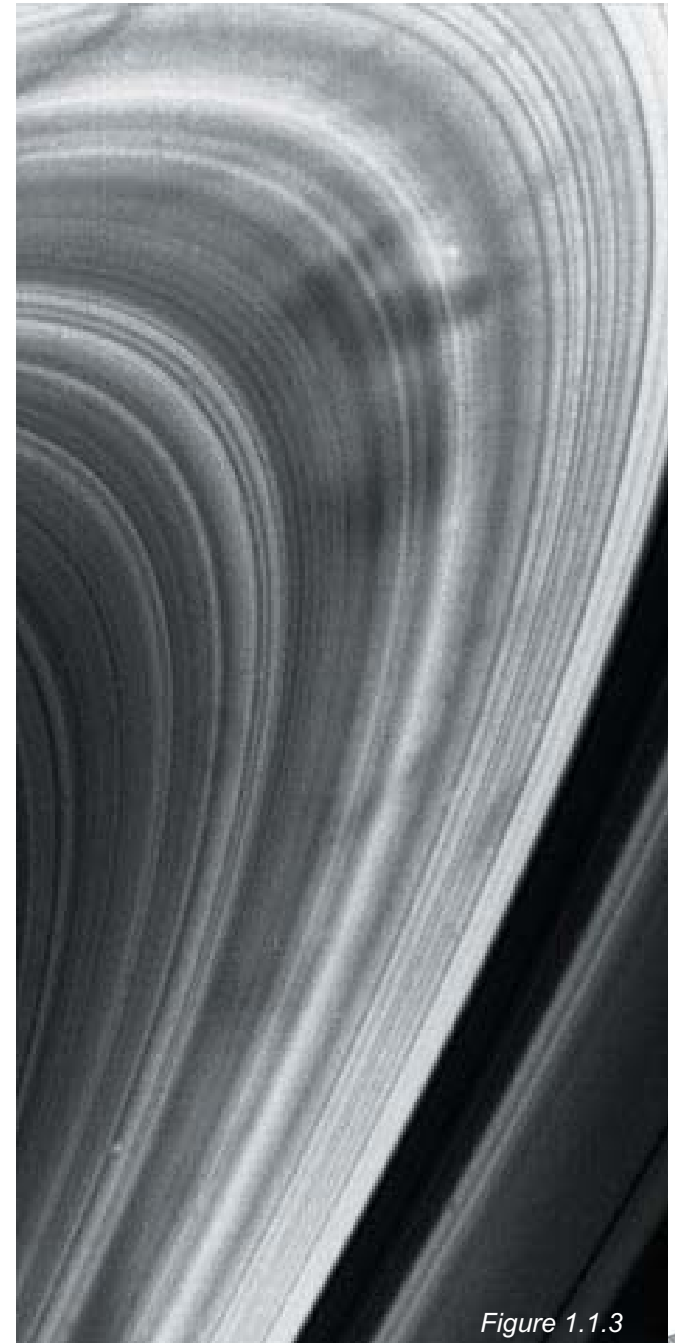

Figure 1.1.3



1.2 The Project

The project is an astronomical education and entertainment facility. The main feature of the facility is a planetarium. Other features include a series of exhibition spaces, a gift shop, a restaurant and administration facilities.

1.2.1 What is a planetarium?

A planetarium is a building that can simulate the cosmos by means of a projection on a half-spherical surface. Apart from cosmic simulation, which is the traditional function of a planetarium, advanced technology now also makes it possible to present educational programs on nearly any related topic - from the science of the inside of an atom to the

increasing threat of global warming. Hence the idea of designing a comprehensive cosmological centre which includes a planetarium.

2.2.2 What will be shown and exhibited?

The presentation media will cover a spectrum of astronomical-related topics ranging from traditional african starlore to current scientific technology. The presentation media will consist of interactive exhibitions. The method of education is intended to be informal, entertaining and accessible to young and old. Exhibitions are intended to be updated constantly and changed to accommodate scientific development and new discoveries.



Figures 1.2.1 - 1.2.5 : Images indicating the versatility of the planetarium

1.3 The Location

The project is located in the new proposed Zoological Gardens Forecourt. The project forms part of a framework that focuses on the upgrade and regeneration of the Zoological Gardens precinct and in turn forms part of the development of the northern gateway of the inner city.

The National Zoological Gardens is a major local and international tourist attraction. It is the second largest urban zoo in the world, houses the third largest exotic plant collection in the world and the largest inland marine aquarium in the world. It therefore provides the community with a place to learn about the earth (fauna and flora) and water. Therefore, it is logical to develop a facility regarding the third element, the sky.

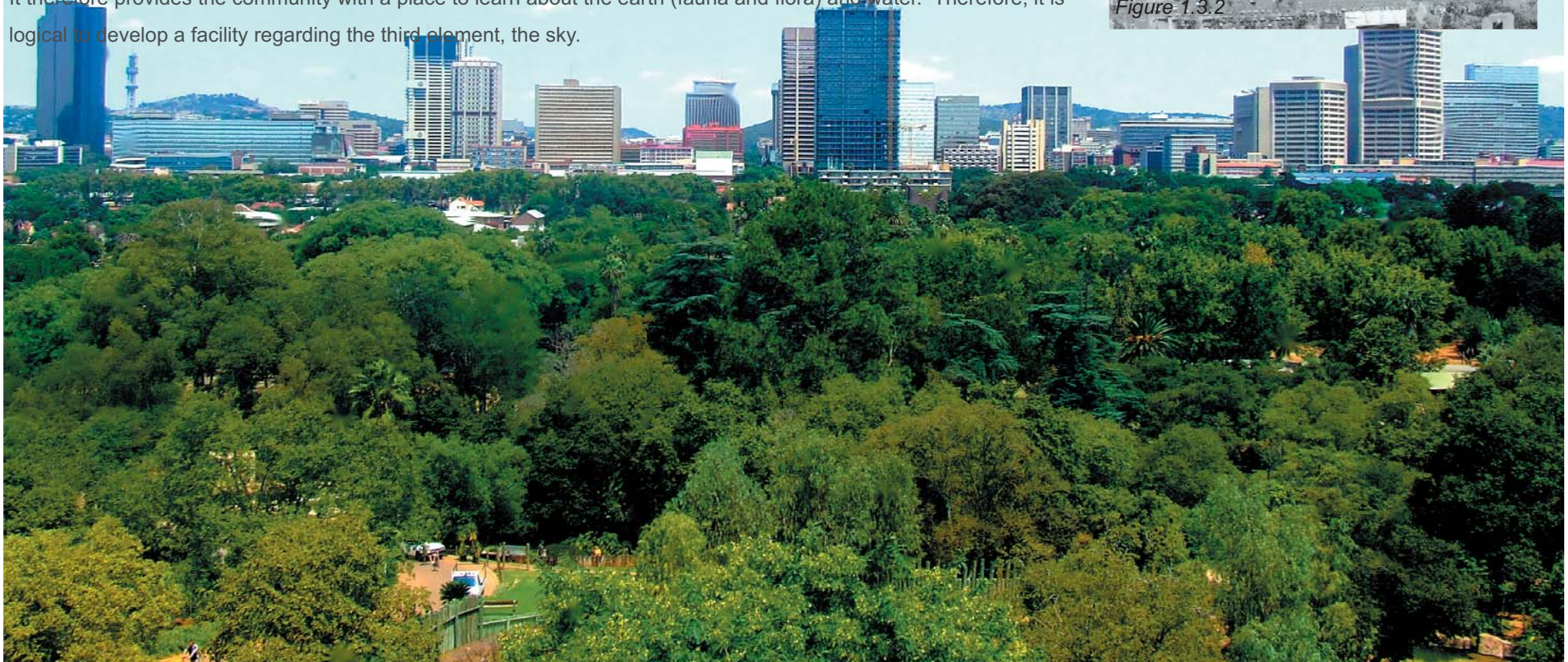
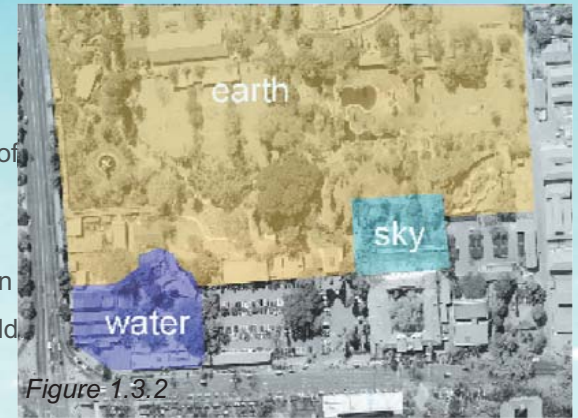

Figure 1.3.1 The National Zoological Gardens



1.4 Why an astronomical centre in the Inner City of Tshwane?

Never before have humans known so much about the universe as we do today (Horak 2007). Never before have we acquired information about the universe as quickly as we do now (ibid). Yet, at the same time, never has the general public been so ignorant about even the basic facts of celestial science (ibid). Technology such as the Hubble Telescope constantly reveals new wonders of the universe. Scientists working in the fields of cosmology and particle physics combine their knowledge in a quest for insight into the origin and destination of the universe and of mankind (ibid).

In South Africa a new focus on astronomy as a branch of science was established by the completion of the South African Large Telescope (SALT), the largest

single optical telescope in the Southern Hemisphere at Sutherland (ibid). South Africa is a strong contender against Australia, for hosting the international Square Kilometre Array (SKA). This giant next-generation telescope is being developed by scientists in 17 countries and will consist of thousands of antennas spreading over 3 000 kilometres (ibid). The SKA is 50 times more sensitive than the most powerful radio telescopes we have now. It has the capacity

to peer deep into the cosmos to pick up signs of the first stars and galaxies to form after the Big Bang and trace the effects of the mysterious dark energy that is driving the universe apart at an increasing speed. It is also capable of mapping out the influence of magnetic fields on the development of stars and galaxies (ibid). As South Africa is in desperate need of dynamic young astronomers to man these projects, more young people have to be exposed to astronomy.

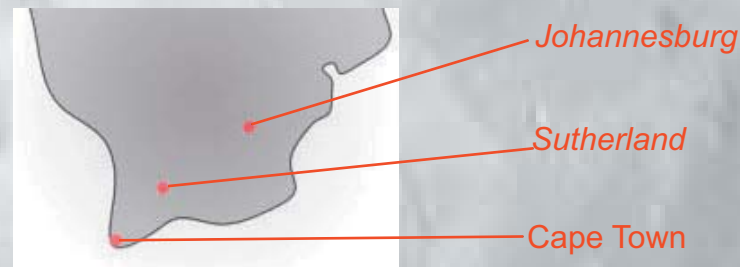

Figure: 1.4.2 Image indicating the location of Sutherland in South Africa

As light and pollution have made it virtually impossible to observe celestial objects, city dwellers have become completely oblivious to the night sky. One can only get a reasonable view of the night sky if one is at least an hour's drive out of the city (Flanagan 2007). Such a location is not easily accessible to city dwellers. Therefore, an astronomy centre in the inner city is the most effective way of introducing people the wonders of the universe and kindling an interest in a career in science and astronomy.

There are approximately 15 000 planetariums around the globe of which most are situated in the northern hemisphere (King 1978). The shows at planetariums mainly focus on the celestial activities visible from the hemispheres they are located in.

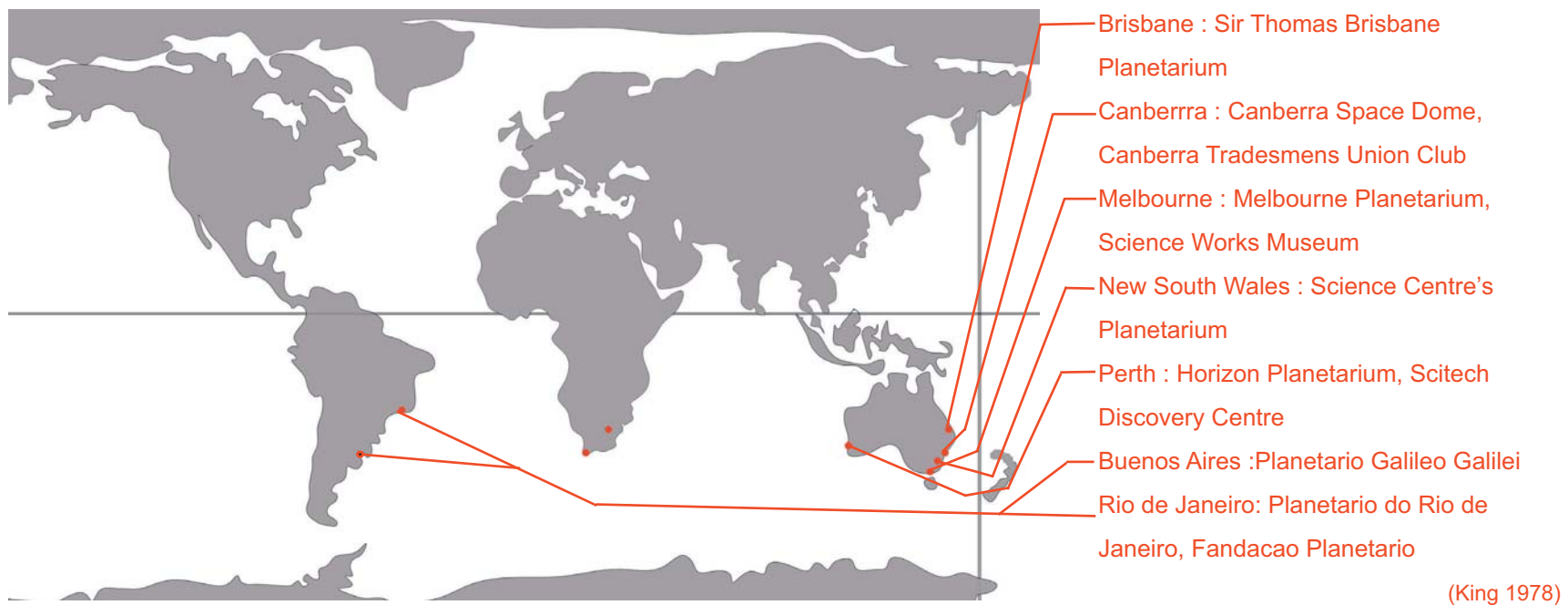

Figure 1.4.4

Figure 1.4.3 Image indicating the location of planetariums in the Southern Hemisphere





Figure 1.4.5



When considering contemporary advances in the field of astronomy and the importance of exposure to pressing environmental issues, the need for science literacy becomes evident. It is submitted that, in the southern hemisphere, South Africa is located strategically to accommodate such a facility (Fig 1.4.2). Tswane is the Capital of South Africa and should house the facility that opens up its skies.

Conclusion

The *Inner City Development Framework Strategy* sets out a number of priorities which should be addressed for the City of Tshwane to become the leading international African Capital City of excellence. The aim of this dissertation is to deal with certain aspects of importance identified by this strategy. These particular aspects are addressed by the development of an educational centre with recreational and entertainment features. The need for education in the field of astronomy is essential both to involve and interest young people in this dynamic field and to create an awareness of pressing environmental matters. This project is located at the National Zoological Gardens and forms part of an urban regeneration framework.

Figure 1.4.6



1.5 Accommodation Schedule

Astronomy Centre Ground Floor

Foyer	72.5m ²
Lobby	324 m ²
Ticket sales	24.5 m ²
Men Toilets	17.5m ²
Ladies Toilets	22 m ²
Disabled	3 m ²
Star Cinema Auditorium	350 m ²
Exit Lobby	140 m ²
Exhibition Holding Area	41.6 m ²
Exhibition Store	8.6 m ²
Staff Toilets	5 m ²

Astronomy Centre Basement 1

Exhibition Lobby	240 m ²
Big Bang Room	240 m ²
Hall of the Universe	527 m ²
Temporary Exhibition Space	260 m ²
Store	11.6 m ²
Men Toilets	20.8 m ²
Ladies Toilets	18 m ²
Disabled	3.5 m ²

Astronomy Centre Basement 2

Hall of the Solar System	266 m ²
African Starlore Room	73.6 m ²
Hall of the Southern sky	380 m ²
Planet Earth Room	250 m ²
Exterior Cosmic Landscape	1240 m ²
Plant Room	135 m ²
Pump room	51.6 m ²
Exhibition storage	58 m ²

Astronomy Centre First Floor

Production

Upper Lobby	12 m ²
Reception	38 m ²
Telescope Deck	60 m ²
Telescope Store	9.8 m ²
Admin Store	5.8 m ²
Kitchenette	13.7 m ²
Production Studio	24.2 m ²
Workshop	35 m ²
Media Archives	17.4 m ²
Storage	10.2 m ²

Administration

Director's Office	18.7 m ²
Administration Office	15.3 m ²
Sales Office	19 m ²
Kitchenette	37 m ²
Conference Room	54 m ²

Gift Shop

Gift Shop	142m ²
Gift Shop	112 m ²
Gift Shop Store	6.5 m ²

Restaurant

Restaurant Reception	75.8 m ²
Men Toilets	10.3m ²
Ladies Toilets	8 m ²
Disabled	3.7 m ²
Bar	22.4 m ²
Bar Store	6.3 m ²
Restaurant Interior	155 m ²
Restaurant Exterior	160 m ²
Kitchen	70 m ²



1.6 Client Profile

National Research Foundation (NRF)
Department of Science and Technology

1.7 User Profile

Local Schools
General Public
Local and International Tourists



Figure 1.5 : Children at the zoo



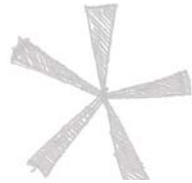
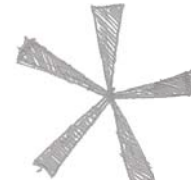

Theoretical Investigation





Figure 2.1.1 :Gravity



Introduction

This following chapter investigates the development of an architectural language that is appropriate for the project. It discusses the value of the man-universe relationship in a Southern African context and explores the expressive qualities of architectural form with regard to this subject.

Boullée argues that: 'the most essential aspect of building is that: the images they offer our senses should arouse sentiments analogous to the use to which these buildings are dedicated'(Rosenau 1974 : 89).

The same is true for architects who consciously attempt to establish specific correlations between space and experience (Thijs-Evensen 1978: 15). As this project is dedicated to the education of astronomy, the objective of the architecture is to create a sequence of spaces that is based on a narrative that communicates concepts of the cosmos. By means of movement through these spaces, ties between mankind and the cosmos are consequently renewed. The exercise is therefore to understand the expressive characteristics of certain architectural forms and to choose those forms which are appropriate for the intended expression.

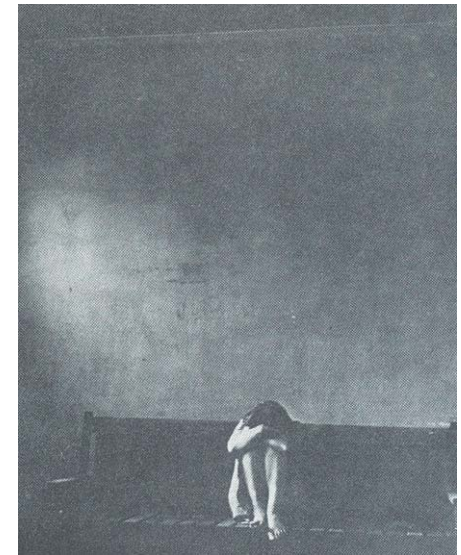

Figure 2.1.2 :Sorrow

A narrative picture will move the feelings of the beholders when the men painted therein manifest clearly their own emotions. It is a law of our nature...that we weep with the weeping, laugh with the laughing, and grieve with those who grieve.

(Alberti, 1979 : 35)



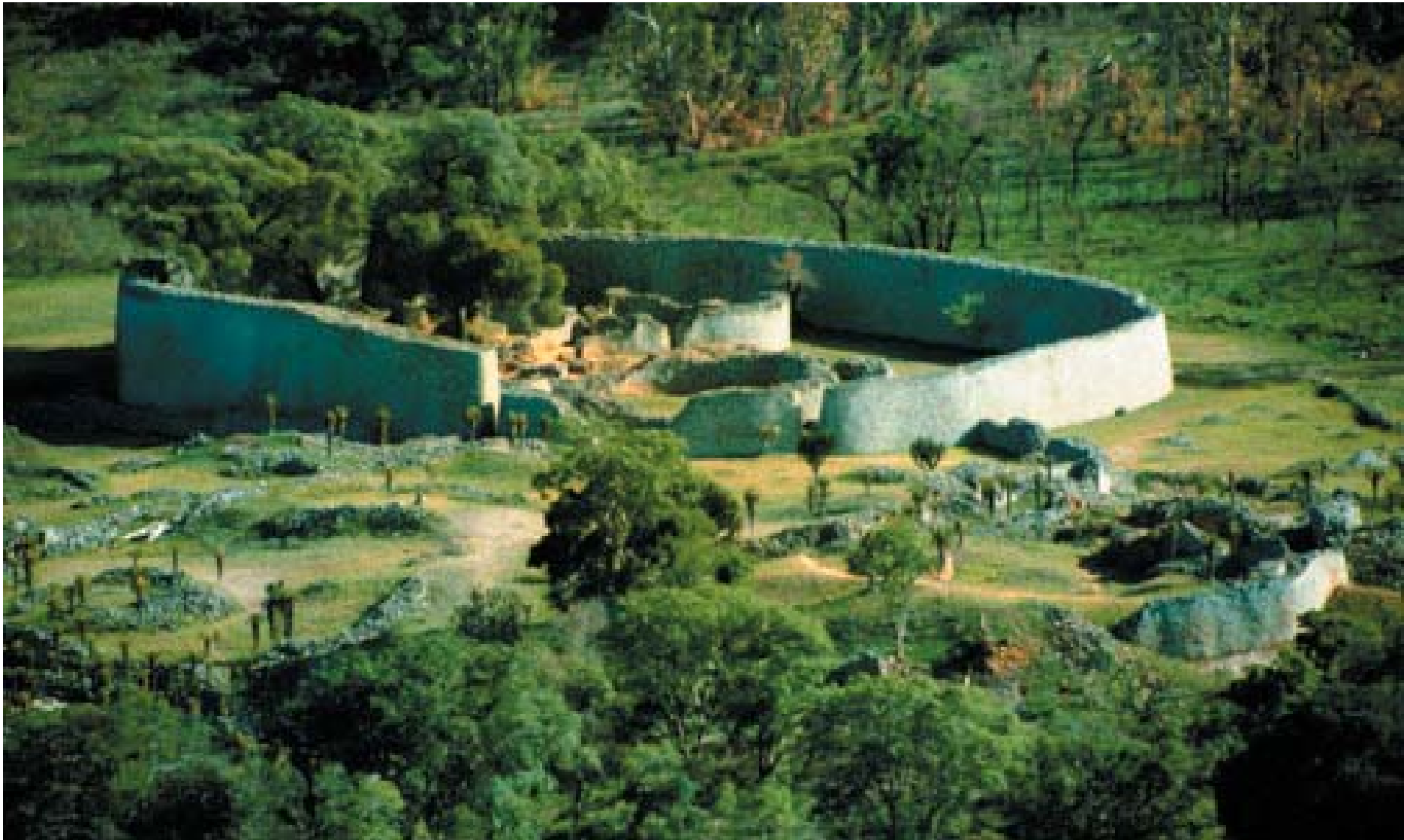

Figure 2.1.3 : The Enclosure at Great Zimbabwe

Archeo-astronomical examinations have led to the discovery that the Great Enclosure's Main Wall was used to define the backdrop of stars, with monoliths marking specific ascending stars and the vernal equinox, amongst other aspects. This makes the Great Enclosure function as a kind of observatory and thus confirming the astronomical traditions of these people (Wade 2007).



2.1 African Skies, African People

The cosmos has captivated the imagination of civilizations throughout the ages. The sky, our common and universal heritage, forms an integral part of the total environment that is perceived by mankind (Lazich et al, 1994: 4). Astronomy and interest in cosmic phenomena are of the oldest intellectual human activities. The rudiments of astronomy exist in all cultures and were evidently important in the concerns of early peoples all over the world (Bronowski 1973: 189).

Properties relating to astronomy stand as a tribute to the complexity and diversity of ways in which people rationalized the cosmos and framed their actions in accordance with that understanding (Lazich et al, 1994: 4). This close and perpetual interaction between astronomical knowledge and its role within human culture is a vital element of the outstanding universal value of these properties (ibid). These material testimonies of astronomy, found in all geographical regions, span all periods from prehistory to today.

The recognition and safeguarding of the cultural properties that transcribe the relationship between mankind and the sky are of particular importance in

Southern Africa. Africans paid attention to the sky and made it part of their story (Rogers 2002). Living close to the earth and the changing seasons, Africans naturally used the stars, the sun and the moon to keep track of time: the time to plant; the time to hunt and the time for ritual to renew the ties between people

and nature (Rogers 2002). Throughout the ages, however, cities and technologies have developed and these rituals have become virtually extinct. Capra argues that city dwellers are dissociated with the cyclical processes of nature, not recognising the interdependence of all phenomena (Capra 1982).



Figures 2.1.4 & 2.1.5 : Our stars today



2.2 Archetype, existential expression and shared experience

Thijs-Evensen discusses the way in which the communicative aspect of architecture is dependant on a number of changing experiential levels (Thijs-Evensen, 1987:23). He groups these in two major

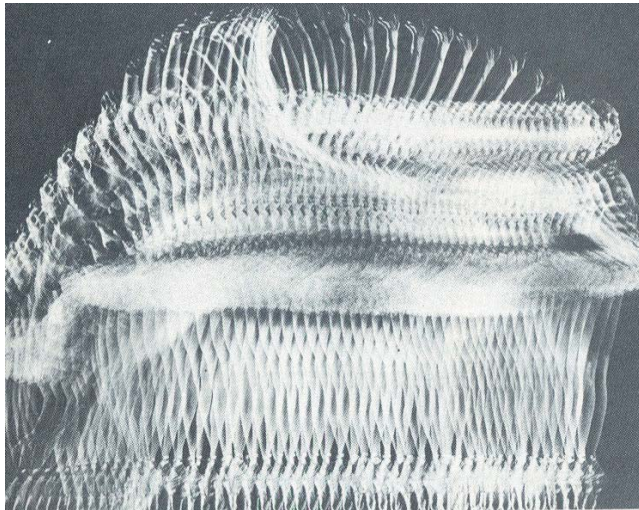

Figure 2.2.1: Man in motion



Figure 2.2.1 : Man and substance

categories, both related to conventions and based on recognition, namely: *private* experiences and social experiences. *Private experiences* are connected to personal experiences and individualities and *social experiences* are related to common cultural associations (Thijs-Evensen, 1987:25). Thijs-Evensen argues that this part of the teachings of expressionism, has been given more attention than any other areas of study within architectural theory. In addition he introduces a third level of experience alongside the private and social levels. This level, independent of personal or cultural determinants, is termed the *universal level* (ibid).

He argues that these *shared experiences* respond to our spontaneous and unconscious reaction to architecture, independent of their symbolic associations. *Shared experience*, like symbolic meanings, are also based on recognition, but this time with reference to our *bodily* experiences (ibid). These experiences can be described in terms of *motion*, *weight* and *substance* (ibid). Such experiences are common to all people and are gained through

confrontations with the physical phenomena which surround us, such as gravity and the forces of nature (ibid). As acting individuals we move in relation to a dynamic reference that is defined by gravity. Day and night provide experiences differentiated by light and dark. Tactile experiences teach us about the differences between hard and soft, coarse and fine, wet and dry (ibid). In other words, the existential expression of an architectural form, which is based on the form's motion, weight and substance, is recognised on the basis of our common experiences of natural phenomena. These experiences form a complex net of references to our place in the universe.

The following section will investigate the expressive qualities of certain architectural forms in order to choose forms which are appropriate for the intended expression needed in the design of the Astronomy Centre. These forms will subsequently be applied in the narrative of the design to create shared experiences on a *universal* level. The investigation categorises forms into three topics, namely the floor, the wall and the roof. It also discusses briefly the significance of making use of geometries in the project.

2.3 Geometries

In the paper *In dialogue with Geometry: The creation of 'Landscape'*, Ando discusses his reliance on the power of geometry (Ando 1988: 24). He argues that geometry is self-contained and informed by pre-established harmony. He argues that geometry has positioned itself through the ages as metaphoric of man's power to transcend nature through reason (ibid)

He discusses the figurative attributes of geometry as being those of simplicity, consistency and repetition and argues that these qualities underscore its character as a product of man's reason, therefore placing itself in contradistinction with nature (Ando 1988: 25). He adds that in the use of geometry that centres on circles and squares, the 'architectural place' will respond by becoming a new totality (ibid).

In addition, in the use of geometry that centres on a sphere and a square, one is able to communicate the relative qualities of an object in space as the horizontal and vertical sections of these forms are the same.

Ching asserts that a sphere is a centralised and highly concentrated form. Like the circle from which

it is generated, it is self-centered and normally stable in its environment. From any point of view, it retains its circular shape (Ching, 1996: 42). He describes the cube as a prismatic solid bounded by six equal square sides. Because of the equality of its dimensions, the cube is a static form that lacks apparent movement or direction (Ching, 1996: 43) In addition, The sphere, calls to mind the dome of the sky, the family of planetariums, the earth and heavenly objects (Pearson, 2000: 100).

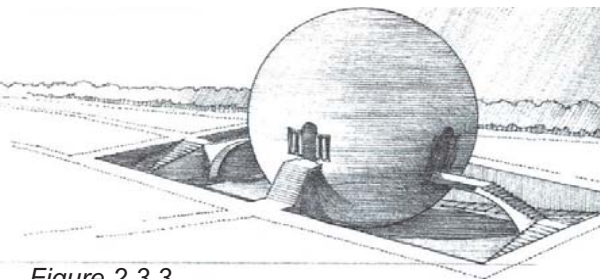

Figure 2.3.3

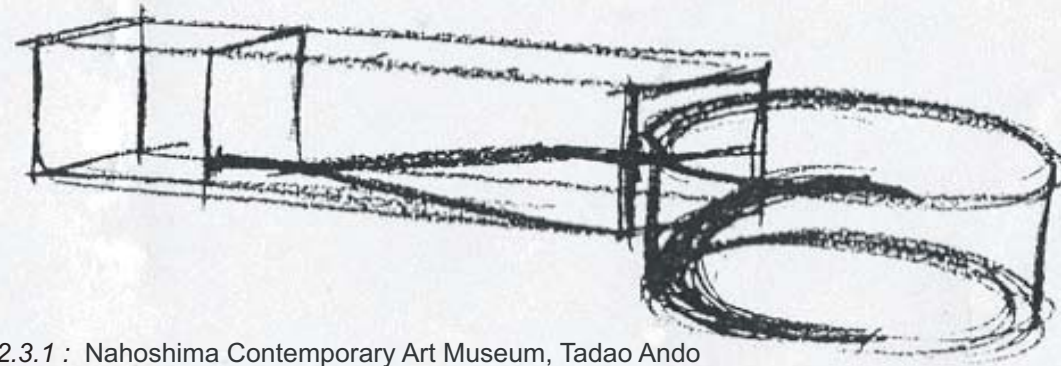

Figure 2.3.1 : Nahoshima Contemporary Art Museum, Tadao Ando

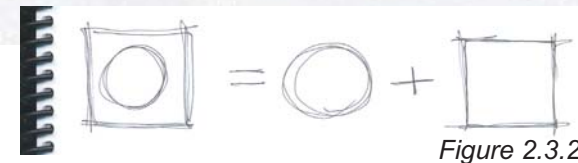

Figure 2.3.2

Design Influences

When considering the expressive qualities of geometrical forms as discussed above, it is submitted to make use of geometries in the design of the Astronomical Centre.

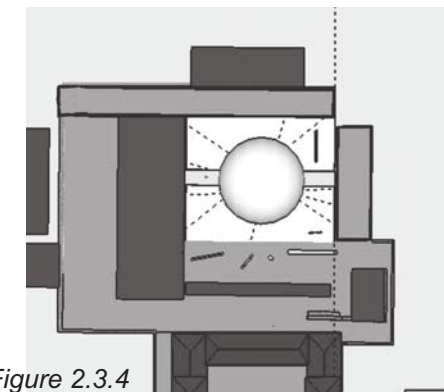

Figure 2.3.4

2.4 The Floor

As creatures of the universe we have *shared experiences* with nature's floor. These experiences determine our impression of the floor in architectural terms. The floor has three main functions in relation to our actions. It *directs us* from one place to another, it *delimits a space* from its surroundings and it *supports us* by providing a firm footing (Thijs-Evensen, 1987:36).

Nature's floor is experienced as a combination of two parts, a surface and beneath it a mass (ibid). It is the surface which illustrates that part of the ground which guides our movements and expresses regional variations. In contrast, the mass below has a far

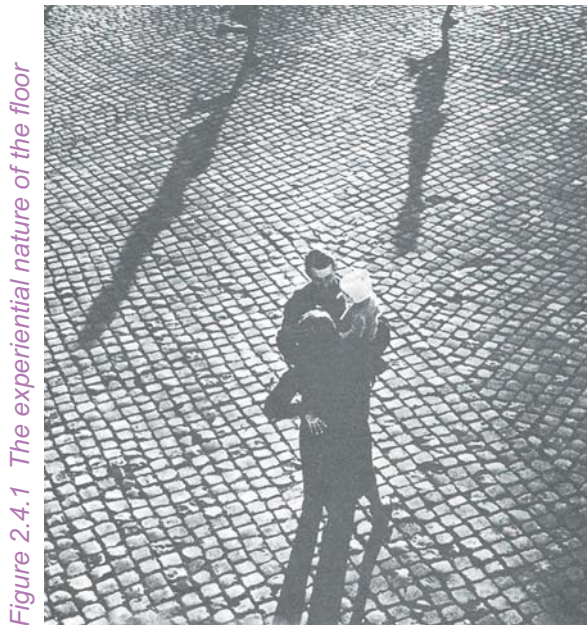

Figure 2.4.1 The experiential nature of the floor

more permanent meaning. As an existential reality it has meaning as it is firm and solid. Thijs-Evensen argues that this firmness is a precondition for our existence on earth, embedded in us as a fundamental background for our entire feeling of security (Thijs-Evensen, 1987:37). He argues that the mass can sink and 'we fall', it can rise up and thereby 'hinder us', or it can be level, giving us 'freedom' of action.

The expressive potentialities in nature's floor are derived through the interplay of surface and mass.

If our actions are above the ground we feel that we have a safe and firm foothold - the ground and we are as one (ibid).

If our actions take place below the ground we are faced with primordial forces as the lower region is unknown and confining. The way in which the surface leads us down into the ground is, however, decisive for our impressions, ranging from an experience to 'fall' or to be 'guided' (ibid).

If the level of our actions are above the ground, our spontaneous reaction is one of independence. We are in control of the ground and liberated from the depths beneath. A feeling of superiority may be the result (ibid).

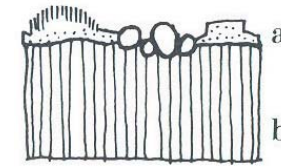

Figure 2.4.1 The parts of nature's floor : the surface and the mass.

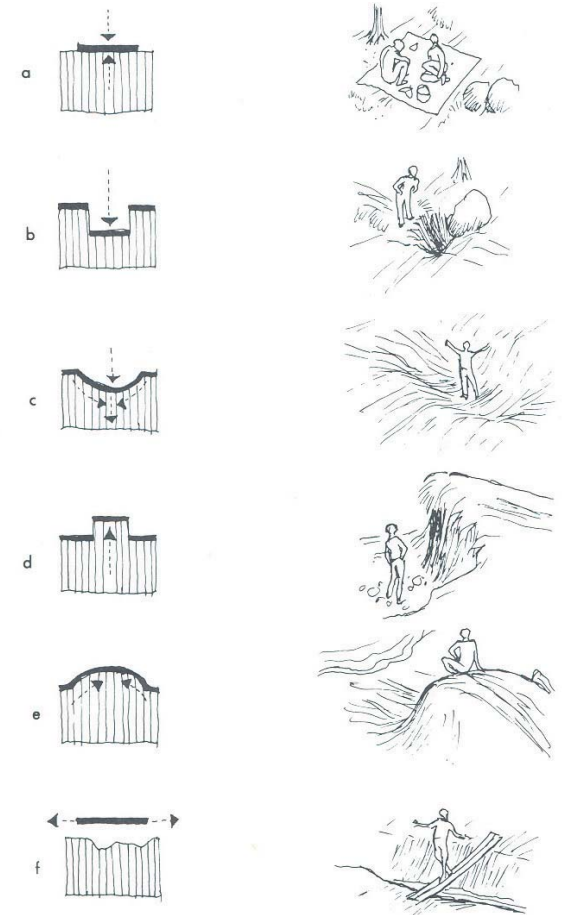

Figure 2.4.2 The expression of nature's floor : the relationship between surface and mass : a) the surface upon the mass, b,c) below the mass, d,e) up out of the mass and f) above the mass.

Design influences

Make use of the following forms of floors that will form part of the narrative of the building.



The attached floor - Emphasizes our conception of the ground as something firm and immovable and conveys the feeling of a solid footing. The floor must rest solidly on the ground and should resemble the ground (Thijs-Evensen, 1987:51)

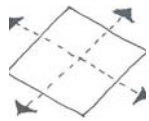

The open floor – This is a floor that opens downwards. It is insecure from a psychological point of view. The depth has a magnetic effect - it sucks us downward – a phenomenon indicating that depth, just as all other types of space, is a potential sphere of activity which we can ‘try out’ by ‘falling’. Therefore the open floor conveys a spontaneous feeling of insecurity and danger (Thijs-Evensen, 1987:63)

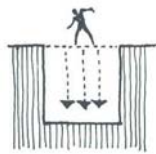

The Mirror floor – This floor gives no main directional indication to the space – we find ourselves in its centre, like the centre of a ‘sphere’ in which all directions are equal. On such a floor we become the affected and ecstatic central point (Thijs-Evensen, 1987:65).

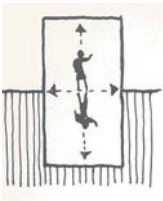

The detached floor – We find ourselves on a level divorced from the ground (Thijs-Evensen, 1987:57).



The sunken Floor – When faced with a downward slanting floor, one feels a spontaneous sensation of accelerating speed. When faced with a sunken floor a basic reaction occurs, dictated by various types of experience. Of particular importance in this regard is the conception of motion as governed by gravity. Here it is the ground itself that takes over, in both an upward and a downward slope. The result however, is exactly the opposite (Thijs-Evensen, 1987:75).

Figures 2.4.3-2.4.7



2.5 The Wall

The wall's architecture is a concrete realization of the existential struggle between an 'attacking' exterior and a 'secure' interior and thereby acquires expressive importance. It is important to understand what it is in the wall's appearance which conveys a message of comparative strength of interior and exterior space and in the way in which this relationship to strength affects its expression (Thijs-Evensen, 1987:116).

The background of our reactions to this relationship is again dependent upon the expressions of motion, weight and substance.



Figures 2.5 The experiential nature of the wall

The wall's relationship to *up* and *down* is reflected in the *theme of heights*(Thijs-Evensen, 1987:142). This involves the meeting between the wall and the earth and between the wall and the sky. In architecture, this is the same as the meeting between the floor and the roof. Down is the direction of the ground and the earth; up is the direction of the sky and air (Thijs-Evensen, 1987: 39). The force of gravity is an essential concept used in mankind's definition of the workings of the universe. It is therefore important to consider what it implies; up is light and free, down is heavy and bound (ibid).

A thick wall corresponds to something inert and closed. Thickness indicates compactness and thereby inner resistance (Thijs-Evensen, 1987: 191). On the other hand, a thin transparent wall, such as a glass wall, conveys a feeling of distance. Furthermore, the effects of such a wall, which include the visual relationship between outside and inside, are dependent upon day and night, lightness and darkness.

During the day the exterior can be drawn inwards and at night it is the interior that is drawn outwards. The shining interior becomes a 'gift' to the night (Thijs-Evensen, 1987: 191).

The vertical wall

The vertical wall is communicative. Firstly, it will always seem lighter because of its rising effect. This wall seems to lift itself upwards and open up vertically. Secondly, the wall itself illustrates the vertical, which marks point and line (Thijs-Evensen, 1987: 145). Horizontal walls draw attention to the corners at each end, while rising walls concentrate attention to the centre of the space. By exploiting this characteristic, one simulates the cosmic concept of the 'sacred centre'. The final reason for the vertical wall's communicative content is that it concerns us directly and personally as either something threatening or conversational, therefore having the potential to become a dominating landmark (ibid).

The horizontal wall

The horizontal wall expresses weight against the ground and has a closed and delimiting character. Because it stretches out horizontally, the impulse is to follow *along* beside it in either direction. Such a space conveys no urge to pause, to turn and enter. The directional space that is created by these walls invites us to enter through the ends (Thijs-Evensen, 1987: 143).

Design influences

Making use of thin vertical walls above the ground, at the entrance and restaurant, where people are intended to gather and linger.

Making use of thick horizontal walls below the ground, in the route of the exhibition, where people are intended to move.

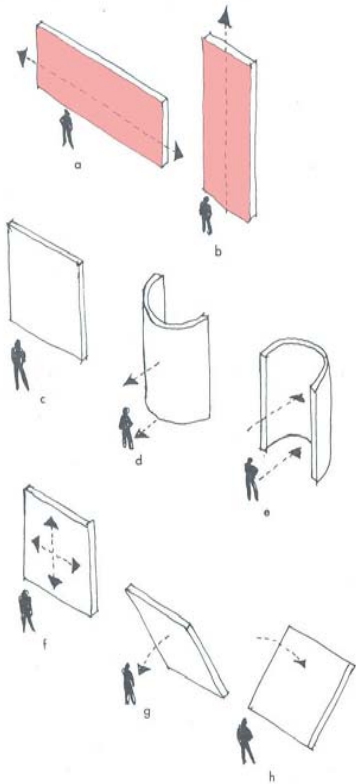

Figures 2.5.1 The main forms of the wall a) horizontal, b) vertical, c) flat, d) convex, e) concave, f) straight, g) leaning toward, h) leaning away

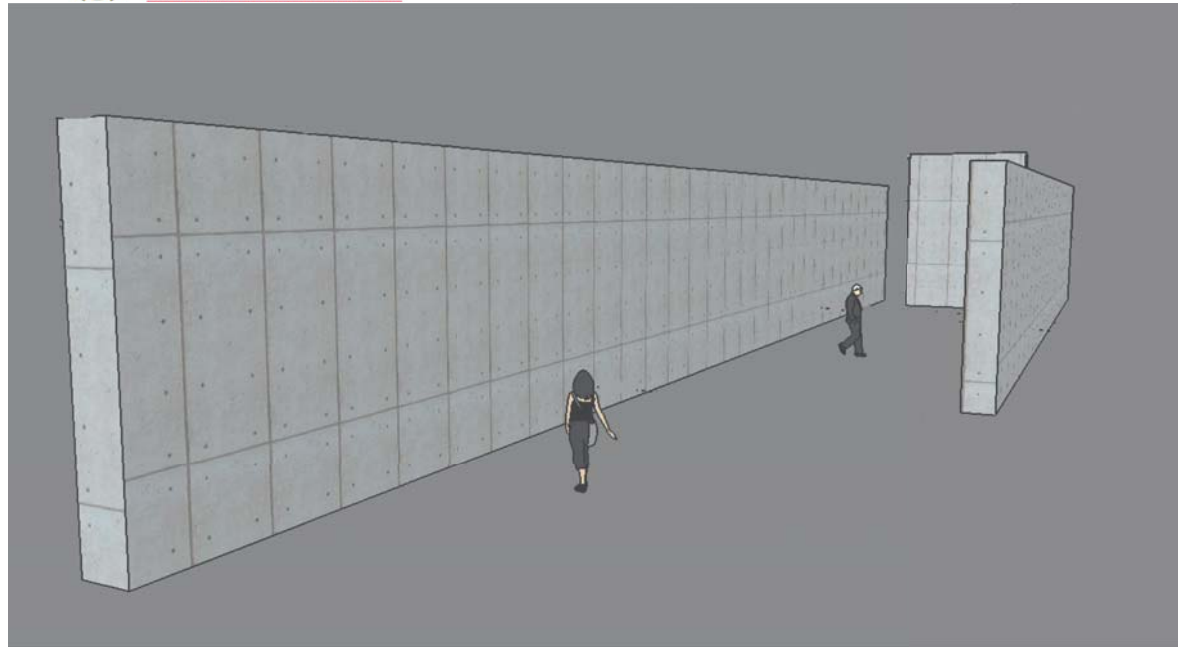

Figures 2.5.2 : Horizontal walls in the exhibition spaces

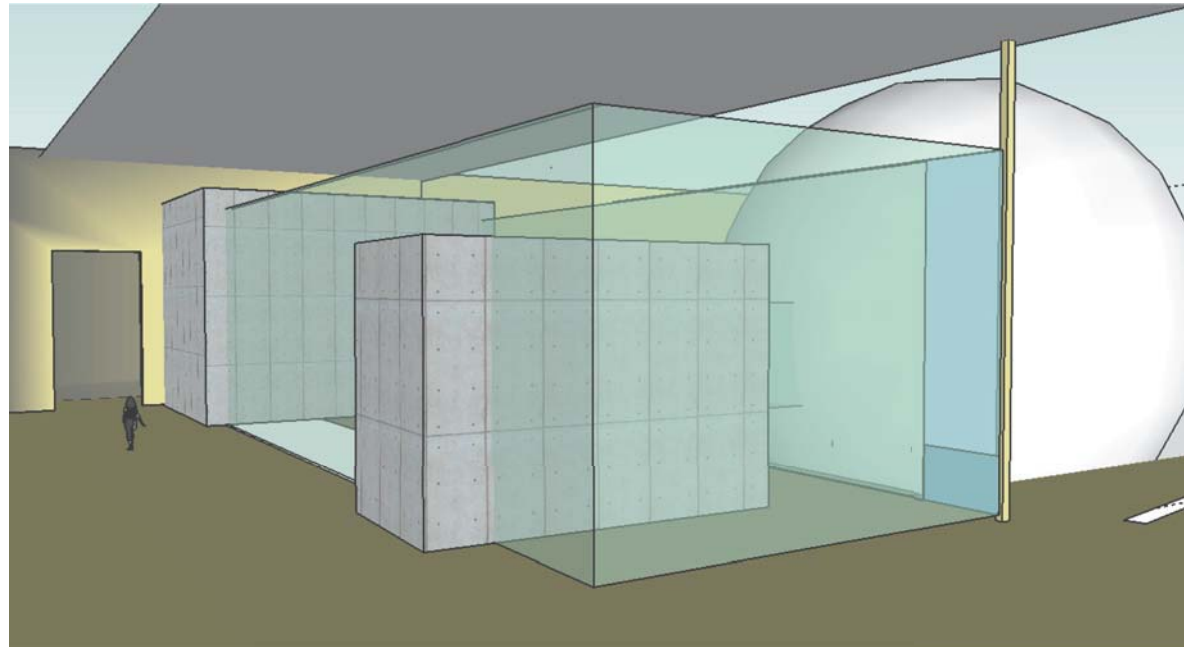

Figures 2.5.3: Vertical walls in the lobby



2.6 The Roof

The expressive qualities of the roofs in this project are of great importance as the exterior space that is bounded by the roof is the sky. Roofs also protect interior space from the surrounding space in the horizontal dimension (Thijs-Evensen, 1987: 301). Throughout history we find variations of shelter forms.



Figure 2.6. The experiential nature of the roof

2.6.1 The Dome

The dome is associated with numerous conceptions and forms. Common to all of them is their reference to conceptions of the cosmos. The main reason for this is that a dome is the reminder of the sky and its very form a replica of the heavenly sphere we have above and around us (Thijs-Evensen, 1987:305). It is therefore an obvious choice of form for the interior of the star cinema, not only for its practicality, but also for its expressive qualities. Thijs-Evensen describes the spherical dome as follows:

'Here all forces are equalised in a perfect calm, completely in keeping with the intention of the space as a symbol of unity between spiritual and human power in an all encompassing universe' (ibid).

2.6.2 The flat roof

Seen from the inside, the flat roof will direct the space equally in all directions. Motion is spread horizontally and in the relationship of above and below the flat roof is like a rigid lid. A flat roof may seem raised or 'hovering' if the roof zone appears to be detached from the walls below. A flat ceiling may appear to be enlarged and expanded. The flat ceiling appears to open up and lighten the inside space beneath.

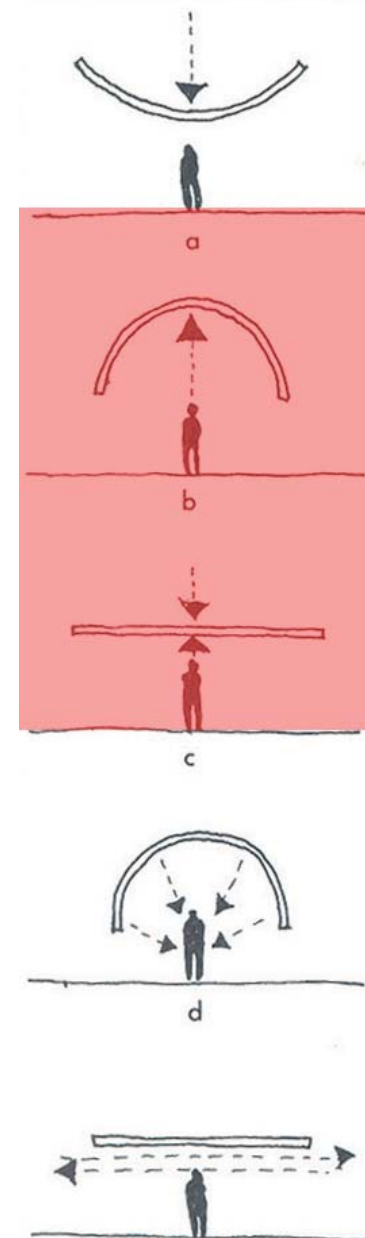

Figures 2.6.1: The roof and its relationship to the sky above: it is able to a) receive the sky, b) resist the sky, c) balance the sky. The roof and its relationship to its surroundings: it is able to a) close the space, excluding the surroundings, e) open the space, including the surroundings.

Design influences

As the project is dedicated to the education of the cosmos, it is logical to use the form of a flat roof as it directs space equally in all horizontal directions and thus communicated the concept of endless space. In addition it is logical to make use of vast vertically defined spaces by making use of form that expands and uplifts vertical space by means of the roof's articulation.

Make use of the form of the half spherical dome in the interior of the auditorium. Extend the form on the exterior into a full sphere. Make use of flat roofs throughout the rest of the facility.

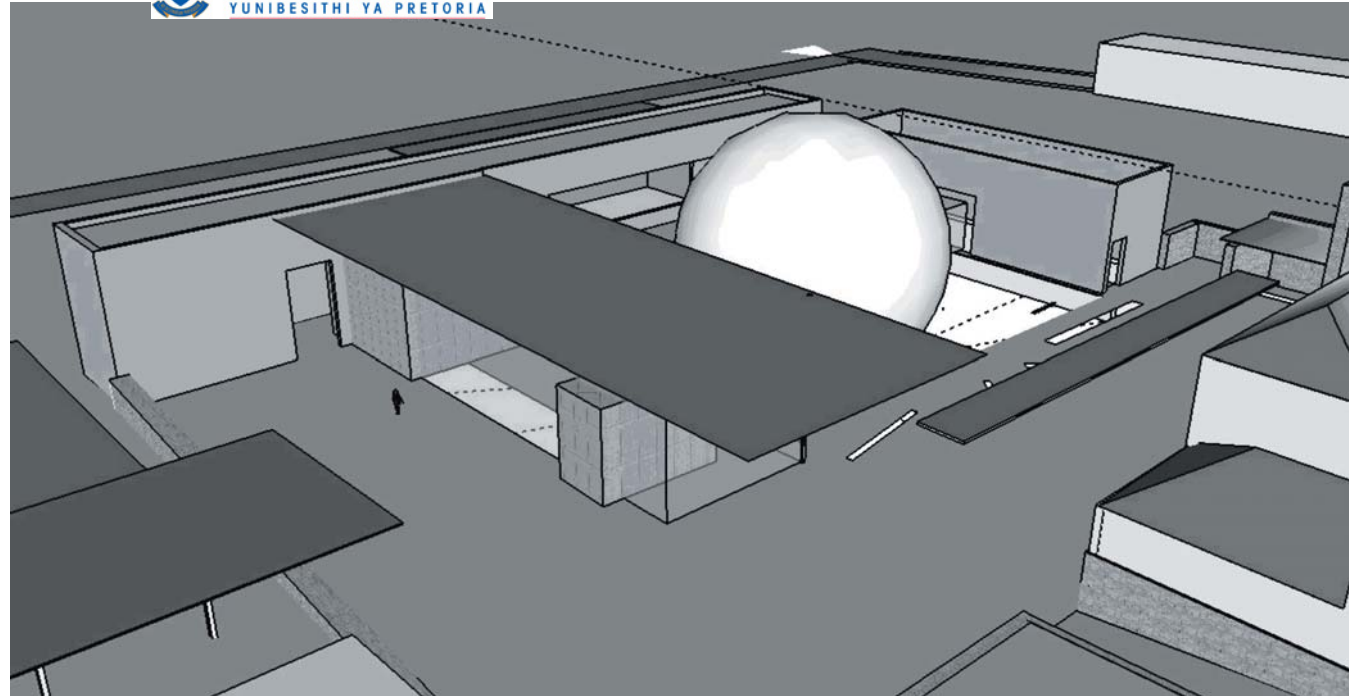

Figures 2.6.3 : Perspective of the astronomy centre indicating the roofs

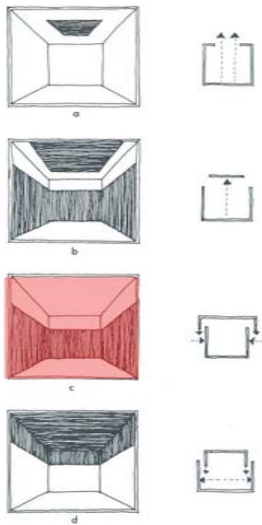

Figures 2.6.2 : Flat roof and the articulated transition between ceiling and wall : a) opening articulation, b) uplifting articulation, c) expanding articulation, d) sinking articulation

Conclusion

This chapter discussed the value of the man-universe relationship in the Southern-African context. It identified the problem that city dwellers have become dissociated with the cyclical processes of nature. In an attempt to re-establish this connection, this chapter analysed how architectural forms with specific expressive qualities can be used in the design to communicate concepts of the cosmos.



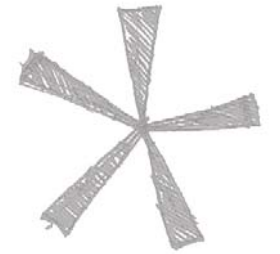

Meso Context

Introduction

This following chapter analyses the Meso Context of the project. The first section will investigate how the form of the Inner City of Tshwane can be defined and analysed by making use of the cosmic model. In the latter sections the focus area of the study and site of the project is identified and analysed.

He states that the primary values behind the concepts are order, stability, dominance, a close and enduring fit between action and form and above all, the negation of time, decay, death and fearful chaos (Lynch, 1987: 79). The following are form concepts in the cosmic model as set forth by Lynch:

The form concepts in the cosmic model and the influence of topography are universal aspects that are clear in the city model of the Inner City of Tshwane

3.1 The Cosmic City

In 'A Theory of Good City Form' Lynch proposes three normative theories whereby the form of a city may be defined and analysed: the organic model, the machine model and the cosmic model (Lynch, 1987: 73). He argues that the form of any permanent settlement should be a magical model of the universe. He asserts that it is a means of linking human beings to those vast forces and a way of stabilizing the order and harmony of the cosmos. He argues that human life is thereby given a secure and permanent place whilst the universe continues its proper sacred motions (Lynch, 1987: 81).

- **Axial line of procession** and approach
- **The dominance of up versus down or big versus small**
- **The sacred centre**
- **The diverse meanings of the cardinal directions** due to their relation to the sun and the seasons
- **The regular grid** for establishing a pervasive order
- **The device of organization by means of hierarchy**
- **Bilateral symmetry** as an expression of polarity and dualism
- **Landmarks** at strategic points as a way of visibly controlling large territories
- **The sacred nature of the environment**

3.1.1 Pretoria as 'Urbs Quadrata'

The central cross refers to the mandala as the primary cosmic ordering principal and connects the four primary wind directions with the heart of the city, where the church was located (Jordaan, 1989 :26).

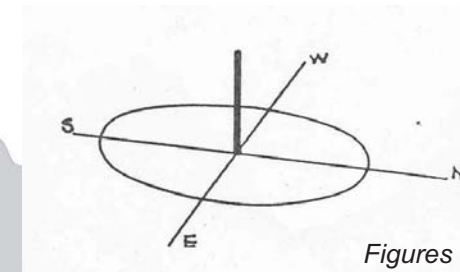

Figure 3.1.7

(Lynch, 1987: 74)

Figures 3.1.1 - 3.1.6



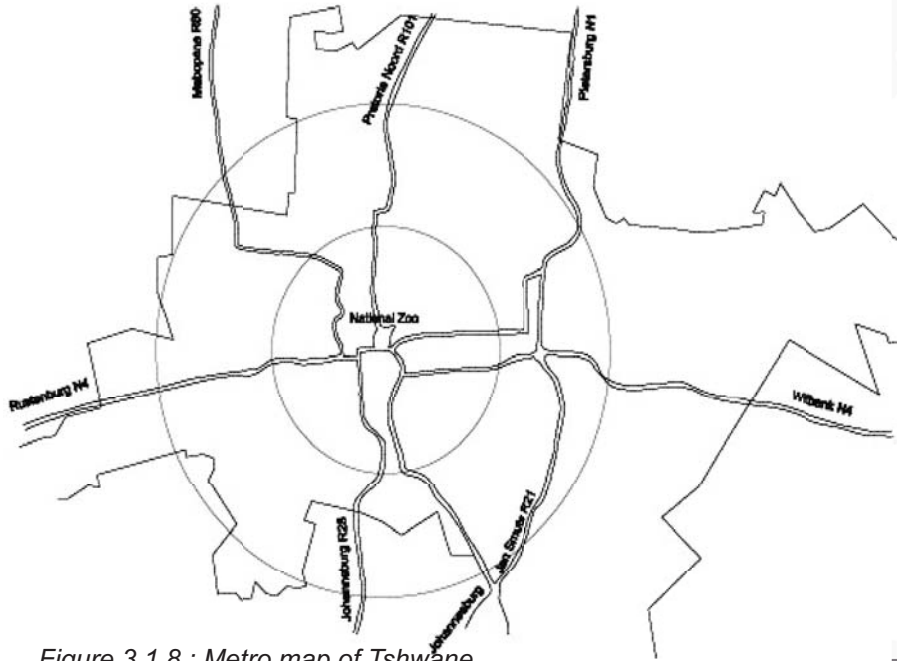

Figure 3.1.8 : Metro map of Tshwane

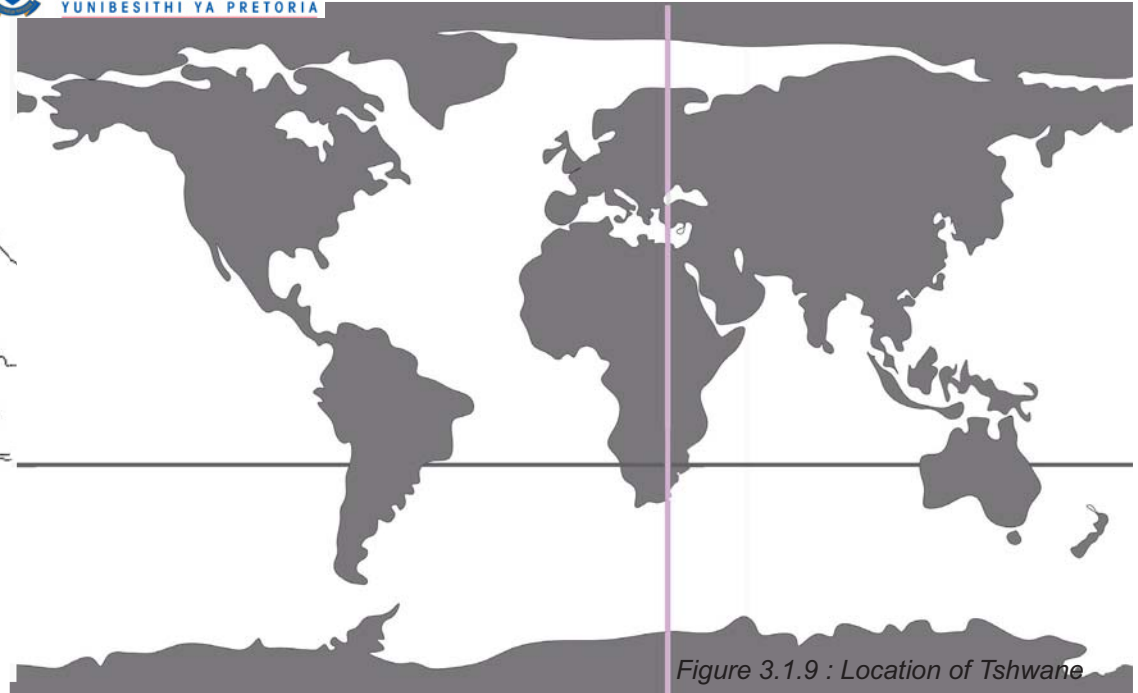

Figure 3.1.9 : Location of Tshwane

The Apiesriver flowed from the east of the city to the west. Contextually the city form is a result of the interpretation of a classical landscape, its mountains, valleys, fountains, rivers and gates (ibid).

The cross of Church and Paul Kruger Streets with the Central Church surrounded by the 'mandala' connects Church Square, as the sacred centre of the city, to the landscape through the river crossings and gates (Jordaan, 1989 :26).

The enclosure inside the rivers and mountain ranges, filled in by the gridiron street layout (ibid).

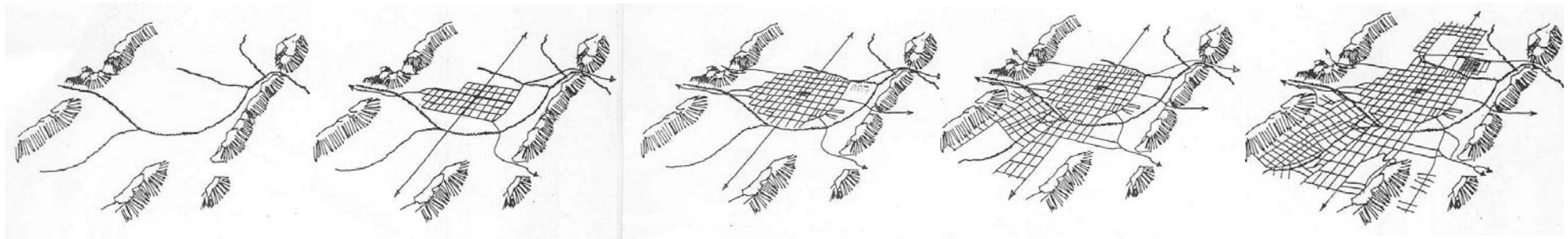



Figure 3.2.1 : Figure ground of the Inner City of Tshwane

3.2 The Tshwane Inner City Development Framework (TICP SDF)

The TICP SDF is a macro-scale urban framework focused on sustaining urban renewal (Kruger 2006: 99).



Figure 3.2.2 : Public space network



Figure 3.2.3 : Core axis



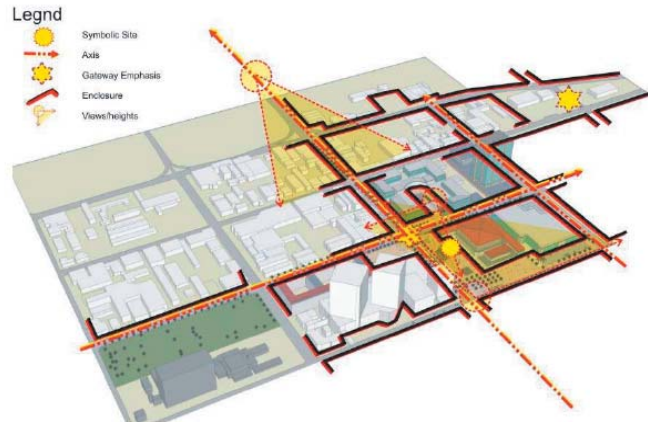

Figure 3.2.4 : Announce the arrival



Figure 3.2.5 : The seven precincts



Figure 3.2.6 : Accentuate green space and public elements

The framework proposes the development of gateways into the city to **announce the arrival in** the capital city. The Paul Kruger North precinct is located on the northern edge of the Paul Kruger Corridor and is the first precinct on arrival from the north.

The framework emphasizes the importance of **accentuating the green space and public elements** in the precinct and suggests the development of three new public spaces, linked by improved pedestrian routes.

Of particular importance is the **entrance forecourt and green space of the Zoological Gardens**. The framework suggests that there should be built additions to this space to create a better performing environment in terms of amenity and attraction. It proposes an upgrade of the Zoo forecourt as a public space and the termination of the Andries Street axis in order to celebrate the Zoo as a tourist facility (Kruger, 2007 : 99).



3.3 Analysis surround

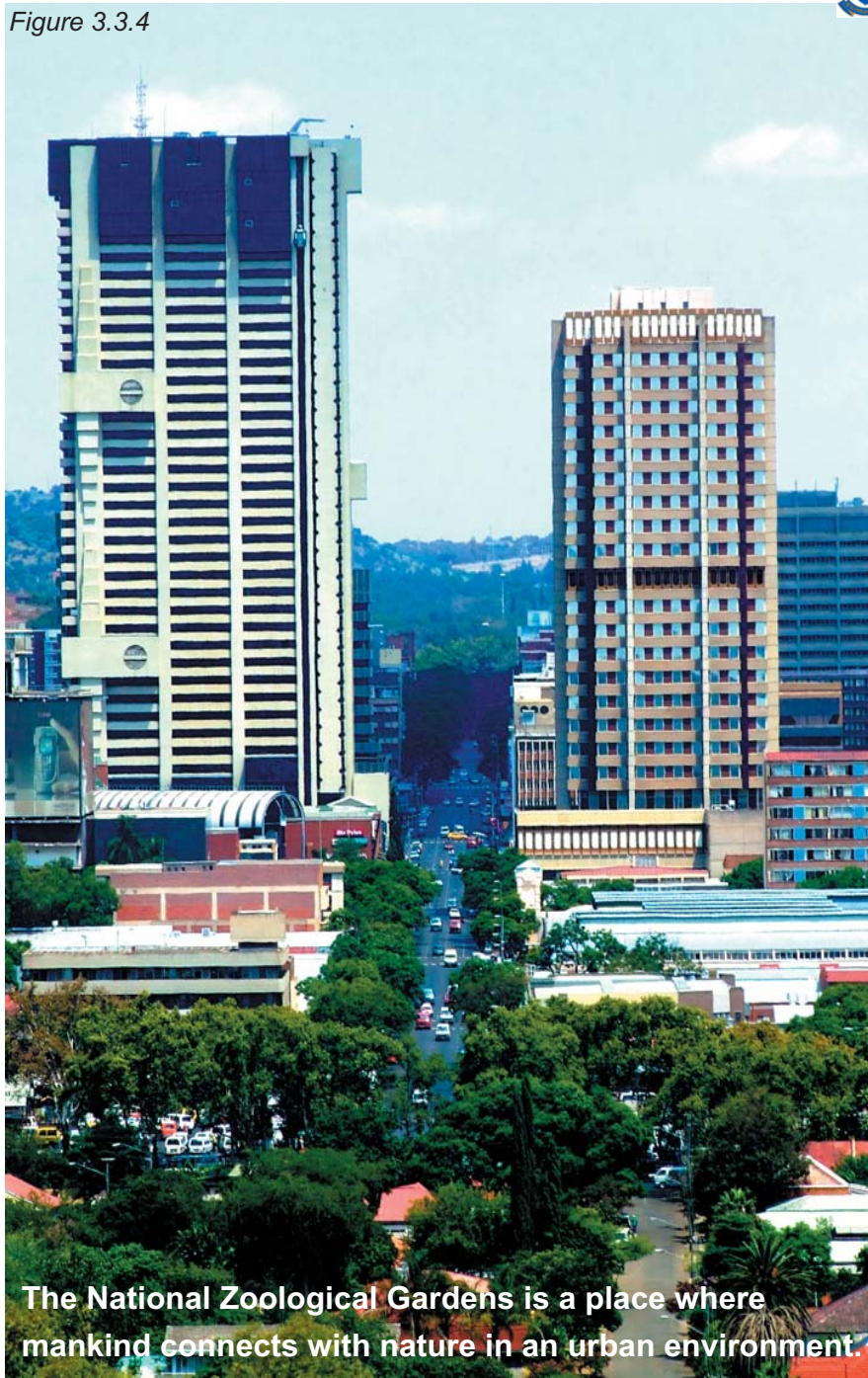

Figure 3.3.1 : Perspective of the CBD of Tshwane



3.4 Site Choice motivation

Figure 3.3.4



The National Zoological Gardens is the second most visited tourist attraction in Tshwane. It is a unique facility as it is the second largest urban zoo in the world. It houses the largest inland marine aquarium in the world and is home to the 3rd largest exotic plant collection in the world. It attracts an average of 550 000 visitors annually and allows for a maximum 5 000 visitors per day (Kitshof 2007). The majority of these visitors are school children. The zoo currently provides the community with a place to learn about the earth and water. It is therefore a logical location for a centre concerning the sky, enhancing the zoo and in turn the northern gateway of the city.

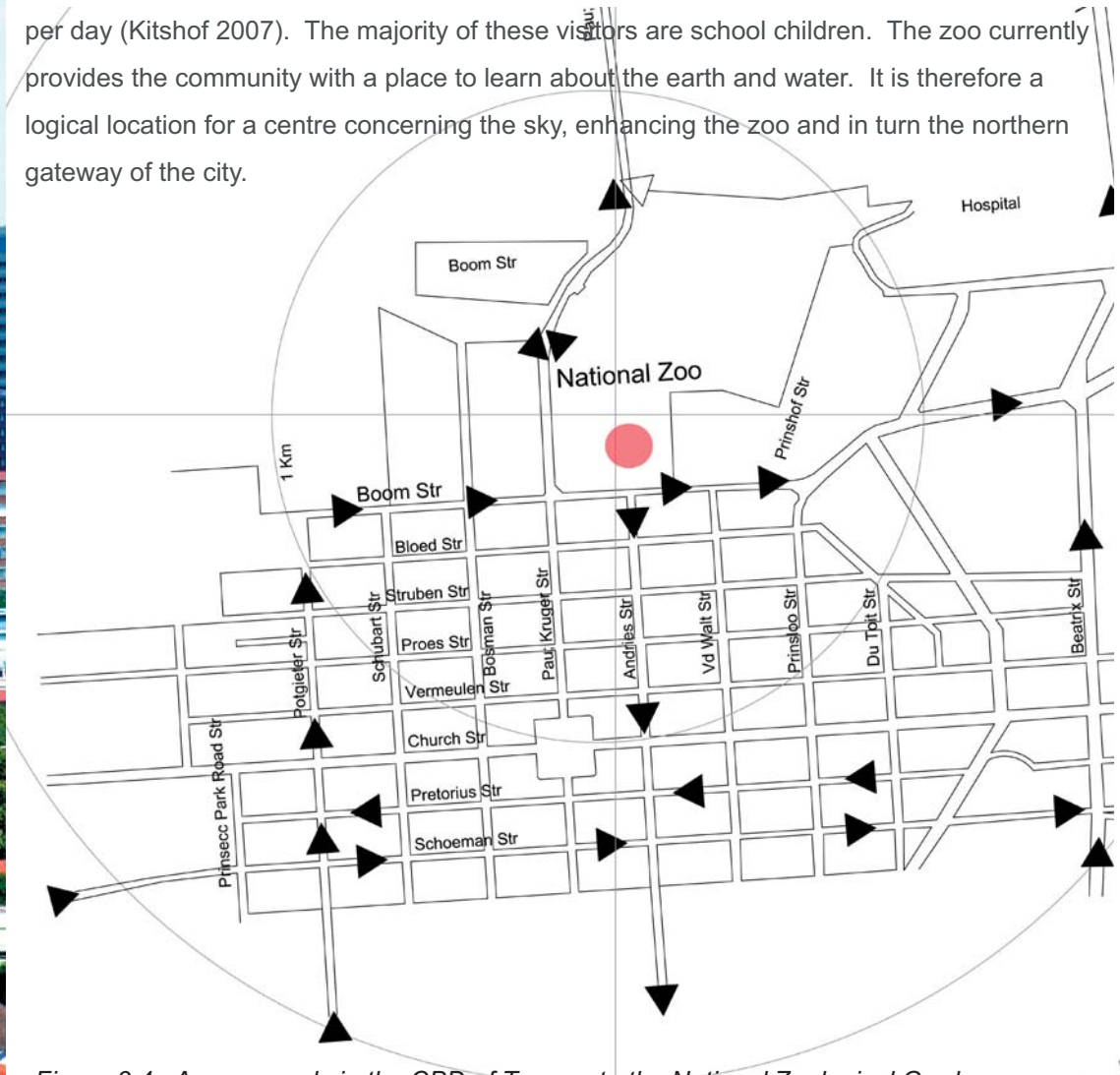

Figure 3.4. Access roads in the CBD of Tswane to the National Zoological Gardens





Micro Context

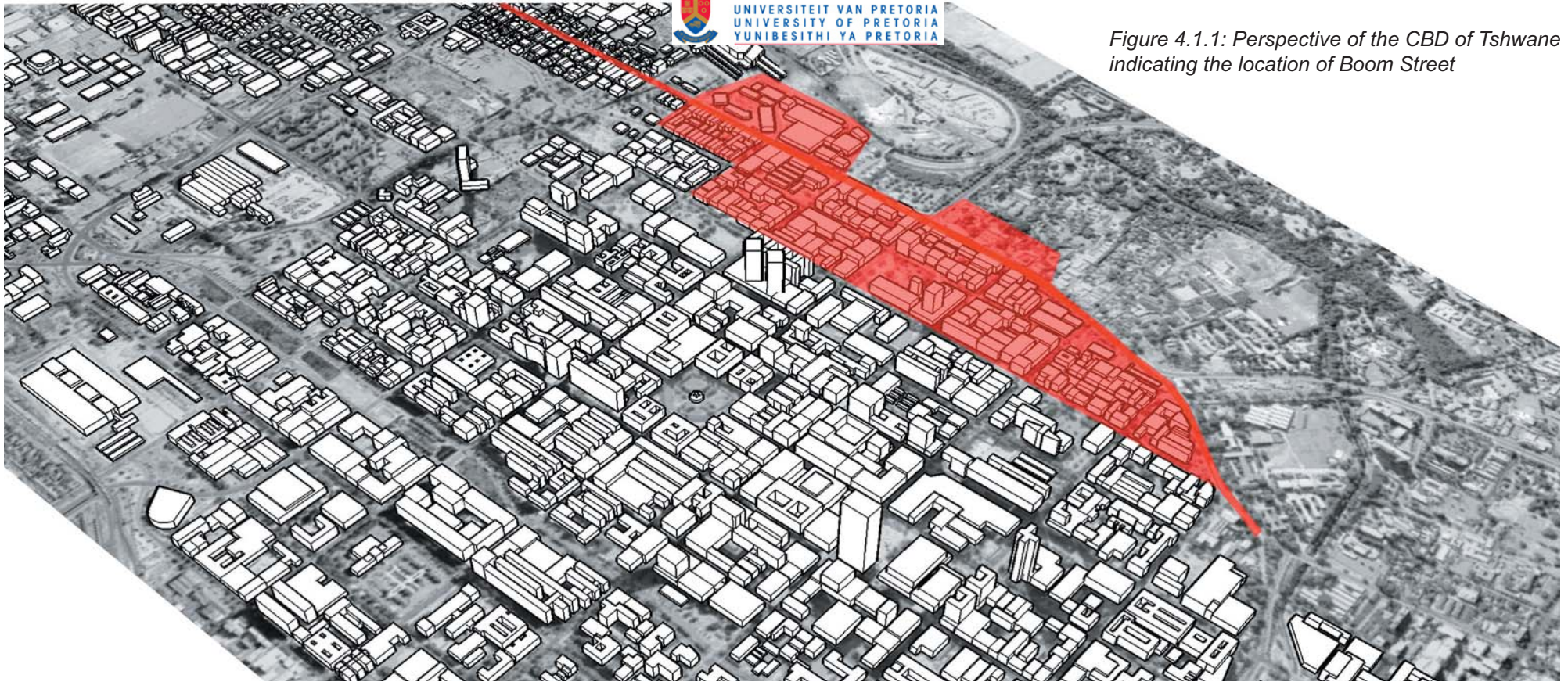

Figure 4.1.1: Perspective of the CBD of Tshwane indicating the location of Boom Street



Figure 4.1.2: Images of the Boom Street Paul Kruger Street crossing facing north

4.1 Boom Street

Boom Street is the street that forms the northern edge of the inner city. The street has a unique identity associated with hawkers. These hawkers form an integral part of the life on the street. The street is currently a vehicle-orientated one way that hampers pedestrian movement and acts as the edge of the city.

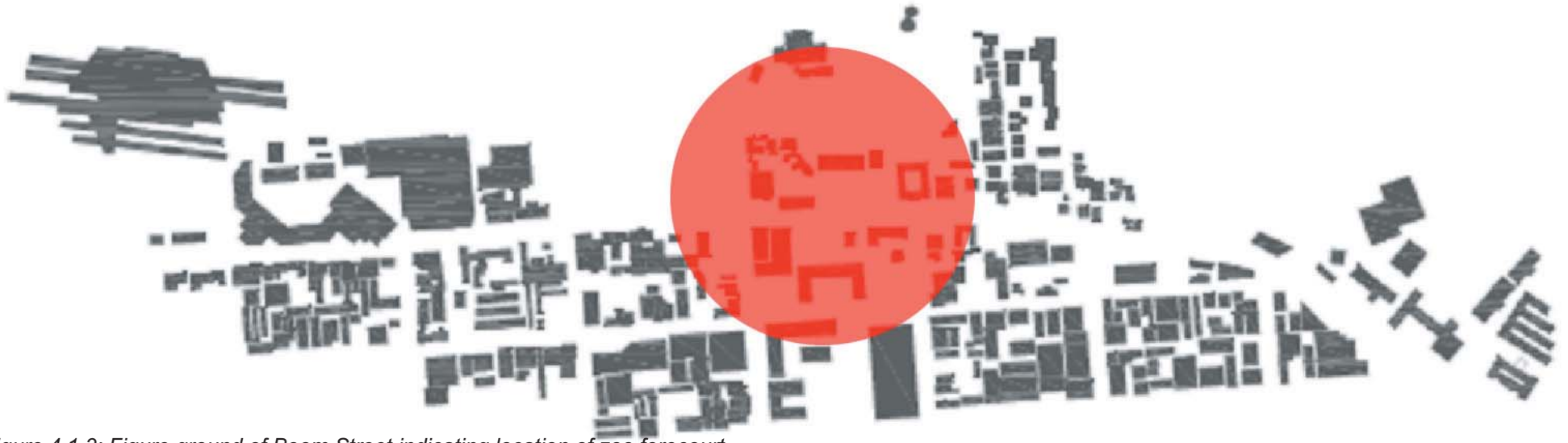

Figure 4.1.3: Figure ground of Boom Street indicating location of zoo forecourt



Figure 4.1.4: Images of the Boom Street Paul Kruger Street crossing facing west





Figure 4.1.6



Figure 4.1.5: Section through Boom Street



4.2 Legal determinants

Existing Zoning (Capitol Consortium, 35 & Meyer, 56)

- To the **east** : Prinshof Precinct, zoned for medical and educational services.
- To the **west** : Marabastad, large component zoned undetermined.
- In the **study area** : zoning allows for a wide range of land uses.

The Zoological gardens (Capitol Consortium, 35 & Meyer, 56)

- Buildings may be erected or used or land-used for : government use
- Floor Space Ratio, height, coverage : Zone 5
- Building Lines : Sides 4.5m, Street boundary 3.5m



Figure 4.2.1: Figure ground of CBD of Tshwane indicating site



Figure 4.2.2: Images of Boom Street and Paul Kruger Street crossing, facing east



Figure 4.3.1 The Historical Z.A.R Museum today



4.3 Analysis surround

The historical Z.A.R Museum is the most important building in this precinct. This national monument was erected in 1899 and is the reason for the location of the Zoo, as it was first established in the backyard of the Museum. The highly decorative, symmetrical building is a typical representative of the era of its construction. The unsympathetic additions that were later added to the building, together with extremely poor maintenance contributed to the dilapidated state of the building at present. The administration of the Zoo is currently in the process of renovating the museum to create an interactive Life Science Museum.

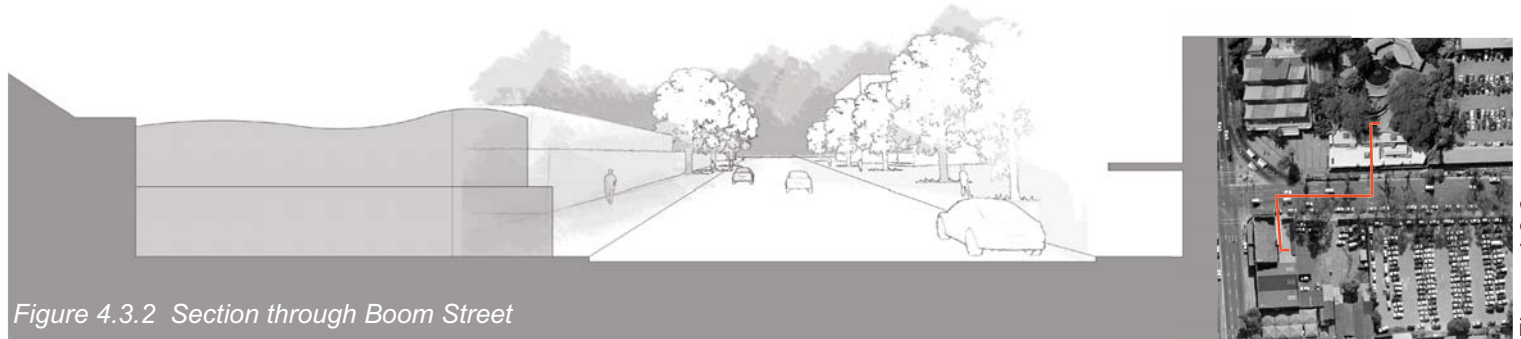

Figure 4.3.2 Section through Boom Street

Figure 4.3.3



Figure 4.3.4 The Historical Z.A.R Museum in 1902





Figure 4.3.7



Figure 4.3.6 : The corner cafe



Figure 4.3.7 : The residential heritage building



Figure 4.3.8 : The flat block

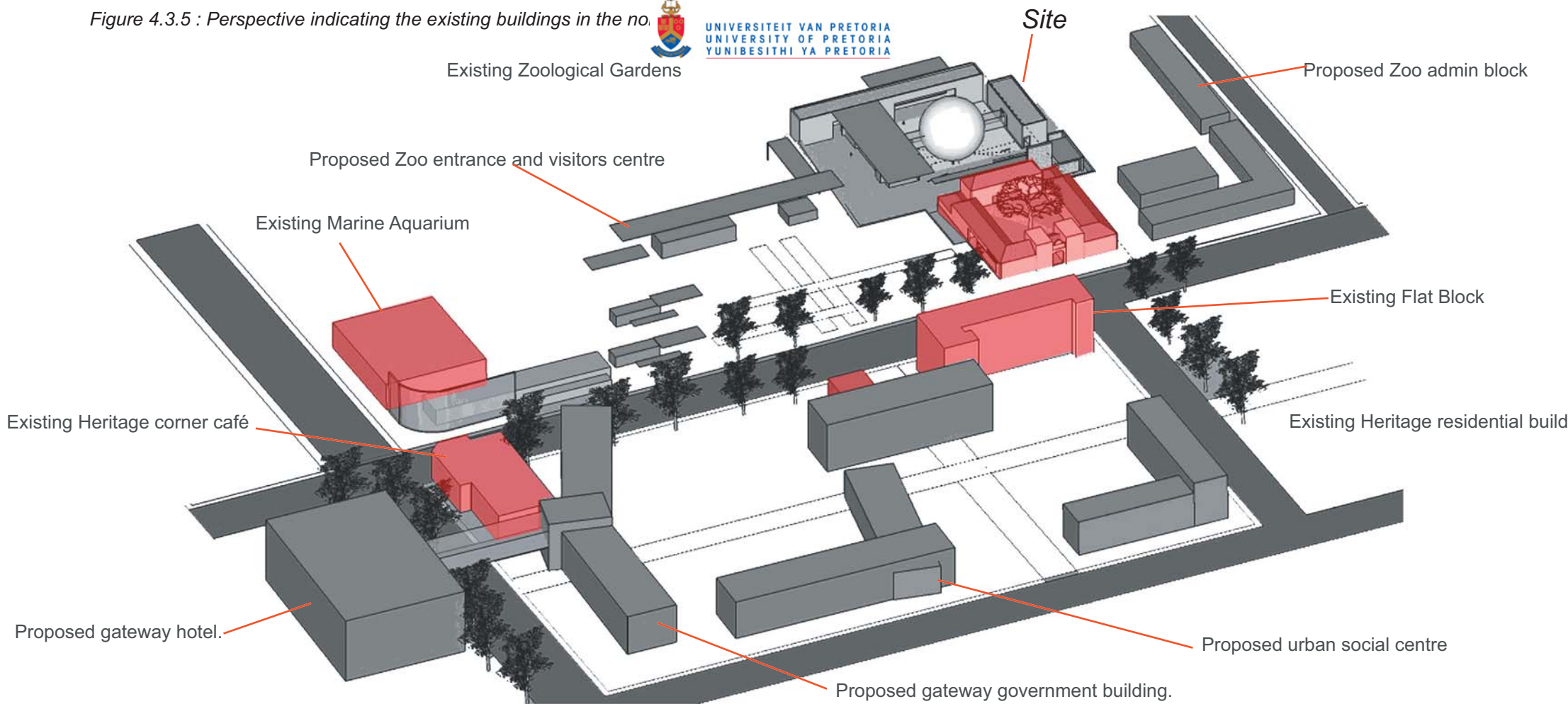

Figure 4.3.9 : The zoo forecourt



Figure 4.3.10 : The aquarium and reptile park



Figure 4.3.11: Zoo map

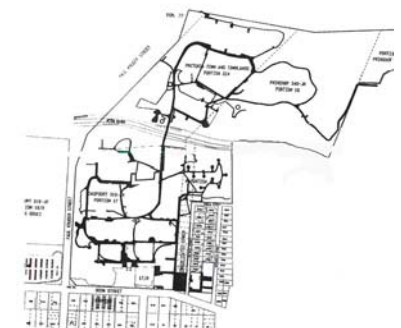

Figure 4.3.12 : Zoo circulation

Figure 4.4.1: Perspective illustrating the location of Boom

4.4 Conclusions and suggestions regarding the meso and micro scale context analysis

City Scale

- The development of an urban foyer at the **northern gateway** of the city is needed.
- **As Paul Kruger Street** is the main road entering the city from the north and Boom Street acts as the northern border of inner city, this crossing should accommodate the gateway.
- A **system that integrates** the

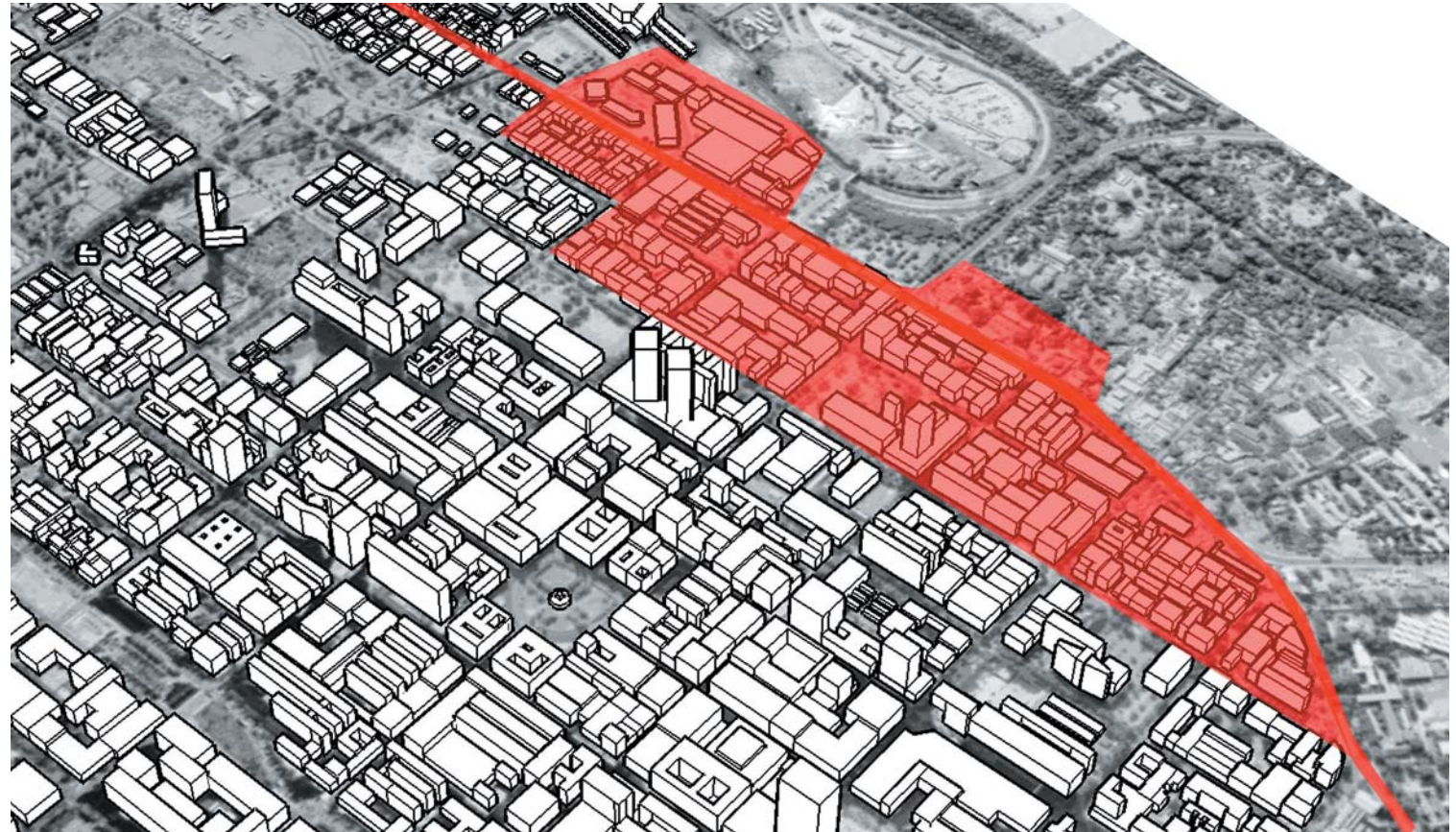

Zoological Gardens with the city on an urban scale should be established.

Boom Street

- Healing the existing **land use** on Boom Street.
- Make use of traffic calming methods in the precinct of the zoo to enable Boom Street to become a **link** between north and south rather than an edge.
- Upgrade the entrance by developing an upgraded **Zoo Forecourt public square** and develop the street block south of the forecourt into a user friendly pedestrian space.
- Take into account the **identity** of Boom Street by considering certain qualities such as its traders.

1) The Zoo forecourt should consist of an upgraded entrance and additional facilities that create a public square. The edges of the square are proposed to be active. By opening up the current enclosed forecourt and fusing the activities of entering the Zoo and local commercial and recreational activities, the development :

- Becomes a **transparent environment** that accommodates day and night activities that contribute to the safety of the area and the general image of the Zoological gardens.
- becomes a **transition** between the Zoological Gardens and the street.
- becomes a space that allows for the daily **interaction** between large amounts of tourists and the general public.

2) **Integrate the historical buildings**, such as the renovated Life Sciences Museum into the development, as they provide an opportunity for historic reference and re-use to serve the new image of this precinct.

3) The Square should **overflow** over Boom Street creating a visual and a pedestrian link into the square south of boom street and hence into the city.

4) The forecourt should link with the surrounding **infrastructure** such as the public transport (belle hombre train station, taxi ranks and new proposed tram and pedestrian boulevards) and existing tourist attractions.

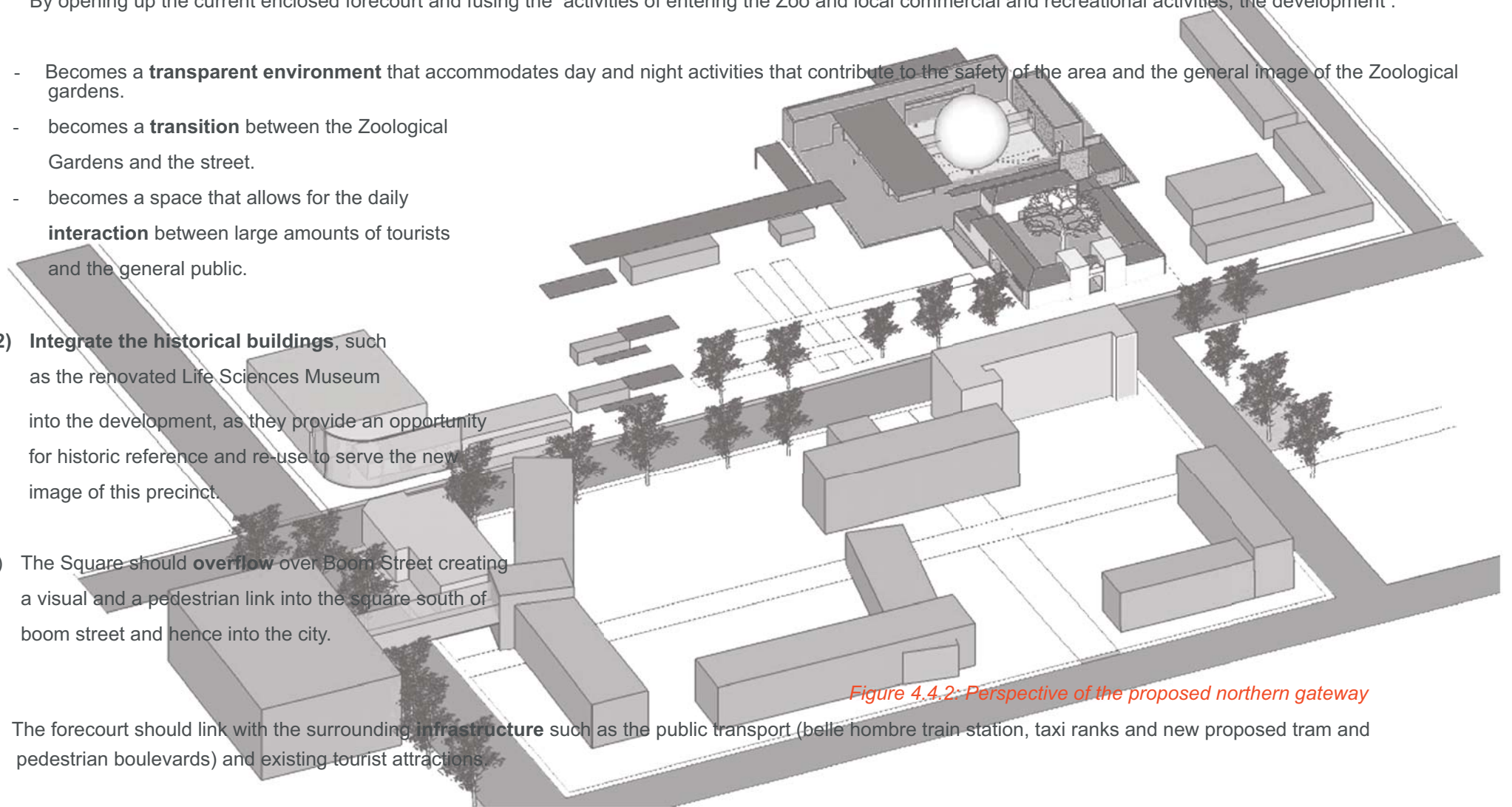

Figure 4.4.2: Perspective of the proposed northern gateway





Precedent Studies

Introduction

The following chapter discusses four precedents that will act as a guiding tool throughout the design process, informing decisions on different levels of development. After a brief discussion of each project, a number of design objectives for the Astronomy Centre will be identified.

5.1 *Fabrica Benneton Art School, Vilorba, Traviso, Italy 1992 – 1994, Tadao Ando*

Fabrica shares its site with a 17th century Palladian Villa. To avoid disrupting the inherited scenery of the site and to minimize the environmental condition, the existing villa was renovated and reused and the new building mostly buried underground (Futogawa 1993 : 218). This structure opens into a sequence of sunken courts or plazas. These plazas become stages of varied interchange (Futogawa 1993 : 218).

In this project, in which the new and the old are combined, the old building was restored and functions independently and the new building designed with reference to the historical style. The introduction of new architecture revitalizes the villa and accentuates its charm. The two styles come together strategically and serve to alleviate the conflict between the styles, for example, at the plaza where there are elements such as light and wind, or at the corridors and lobby (Ando et al, 2001: 90).

Tadao Ando explains that the concept of the building was to ‘accentuate the spirit of the new, producing creative energy from dialogue with the past and to realise the concept through an essentially practical programme’ (Futogawa 1993: 218).

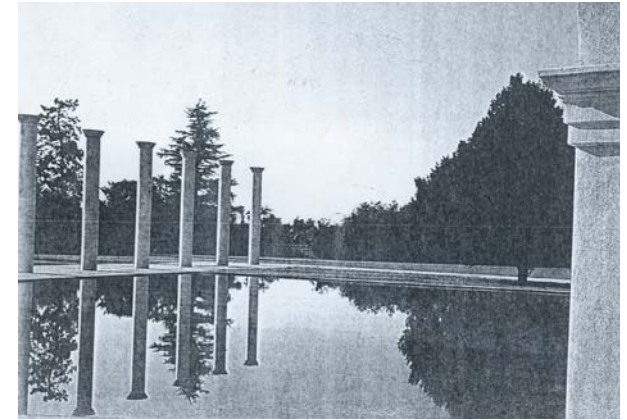

Figure 5.1.2

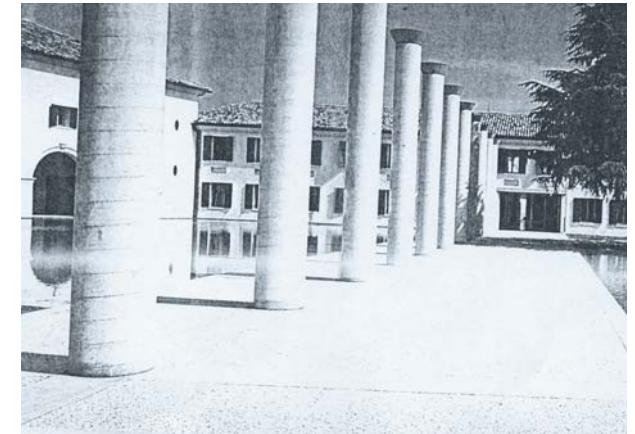

Figure 5.1.3

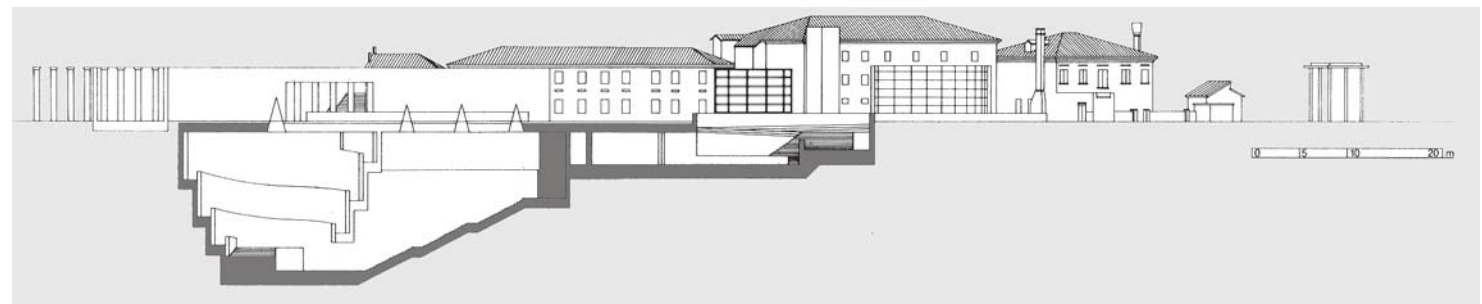
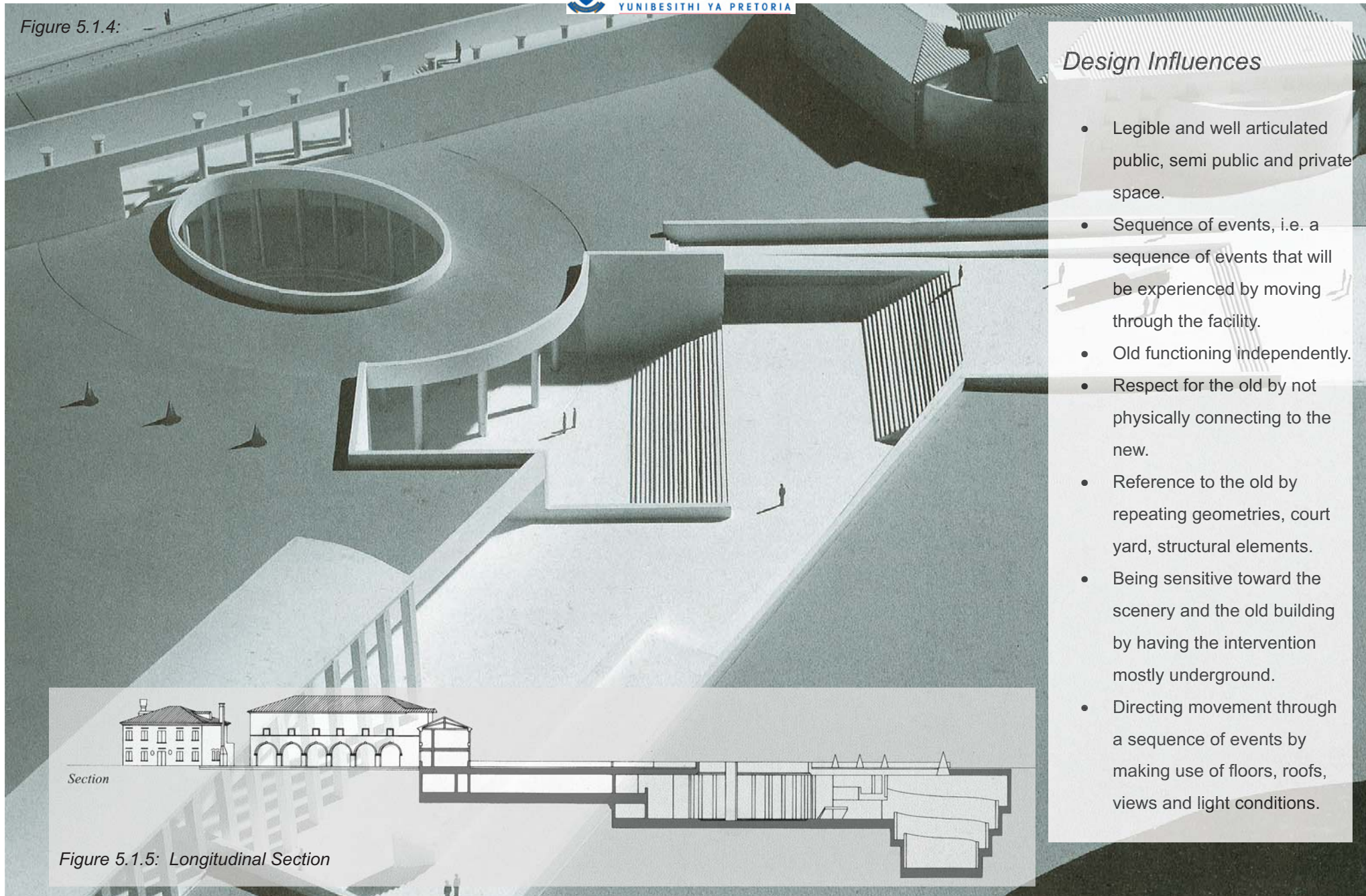

Figure 5.1.1: Section



Figure 5.1.4:



- ### Design Influences
- Legible and well articulated public, semi public and private space.
 - Sequence of events, i.e. a sequence of events that will be experienced by moving through the facility.
 - Old functioning independently.
 - Respect for the old by not physically connecting to the new.
 - Reference to the old by repeating geometries, court yard, structural elements.
 - Being sensitive toward the scenery and the old building by having the intervention mostly underground.
 - Directing movement through a sequence of events by making use of floors, roofs, views and light conditions.

Figure 5.1.5: Longitudinal Section



5.2 Extension of the Reina Sofia National Museum, Madrid, 2001, Jean Nouvel

The Reina Sofia is home to Madrid's contemporary art collection. The building is the old general hospital built in the 1760's. The massive cubic edifice represents the large scale works undertaken by Carlos III in his attempt to give Madrid the splendor worthy of other European capitals of the day. As a result of financial complications, the original design of the hospital had to be reworked. Therefore the building was deprived of the façade, to open onto the prominent Calle de Atocha (Carbonero 2001, 337). The museum does, however remain a marker; its foreign presence signals a significant point in Madrid. The extension, located along calle de Atocha, re-appropriates the functioning and urban identity of the museum (Carbonero 2001, 337).



Figure 5.2.2: Section



Figure 5.2.1: Section



Figure 5.2.3: Section

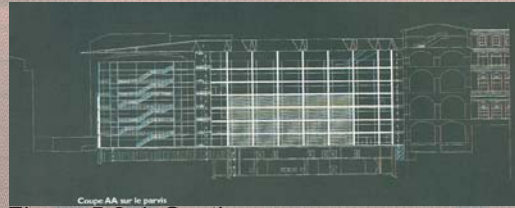

Figure 5.2.4: Section

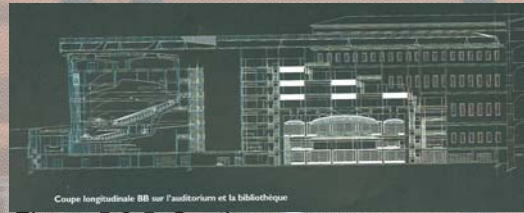

Figure 5.2.5: Section

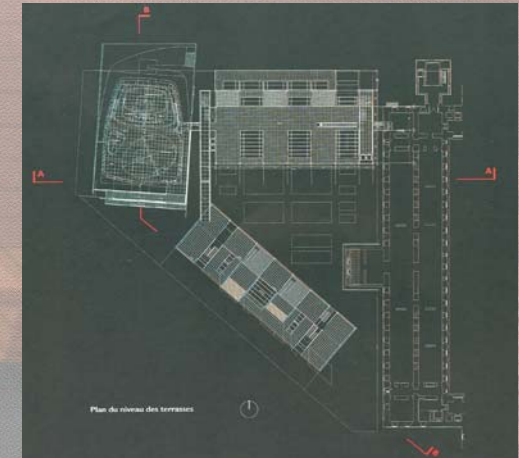

Figure 5.2.6: Section

Design Influences

- Re- appropriate the functioning and the urban identity of the old facility by creating a sequence of spaces that integrate the old and the new.
- The transparency of the extension with its 'light' steel elements contrast to the solidity of the existing structure.
- The extension is sensitive toward the existing structure as it responds to its scale.
- Materials make direct reference to the old, such as the repetition of the red roof finish and repetition of certain horizontal and vertical rhythms.
- The facility accommodates public gathering.

Figure 5.2.7: Section

5.3 Rose Center for Earth and Space, New York, 2000, Polshek Partnership

This typological precedent is probably the most important one to influence the design of the astronomical centre. In the Rose Center for Earth and Space the architects at the Polshek Partnership reduced architecture down to platonic forms – a cube and a sphere. The result is a building immediately recognizable as an icon. Pearson argues that by combining the grand with the ethereal, the Rose Centre achieves a sense of timelessness that hints at the mysteries of the cosmos (Pearson, 2000: 100). The

Figure 5.3.2: Inside the Rose Centre for earth and space

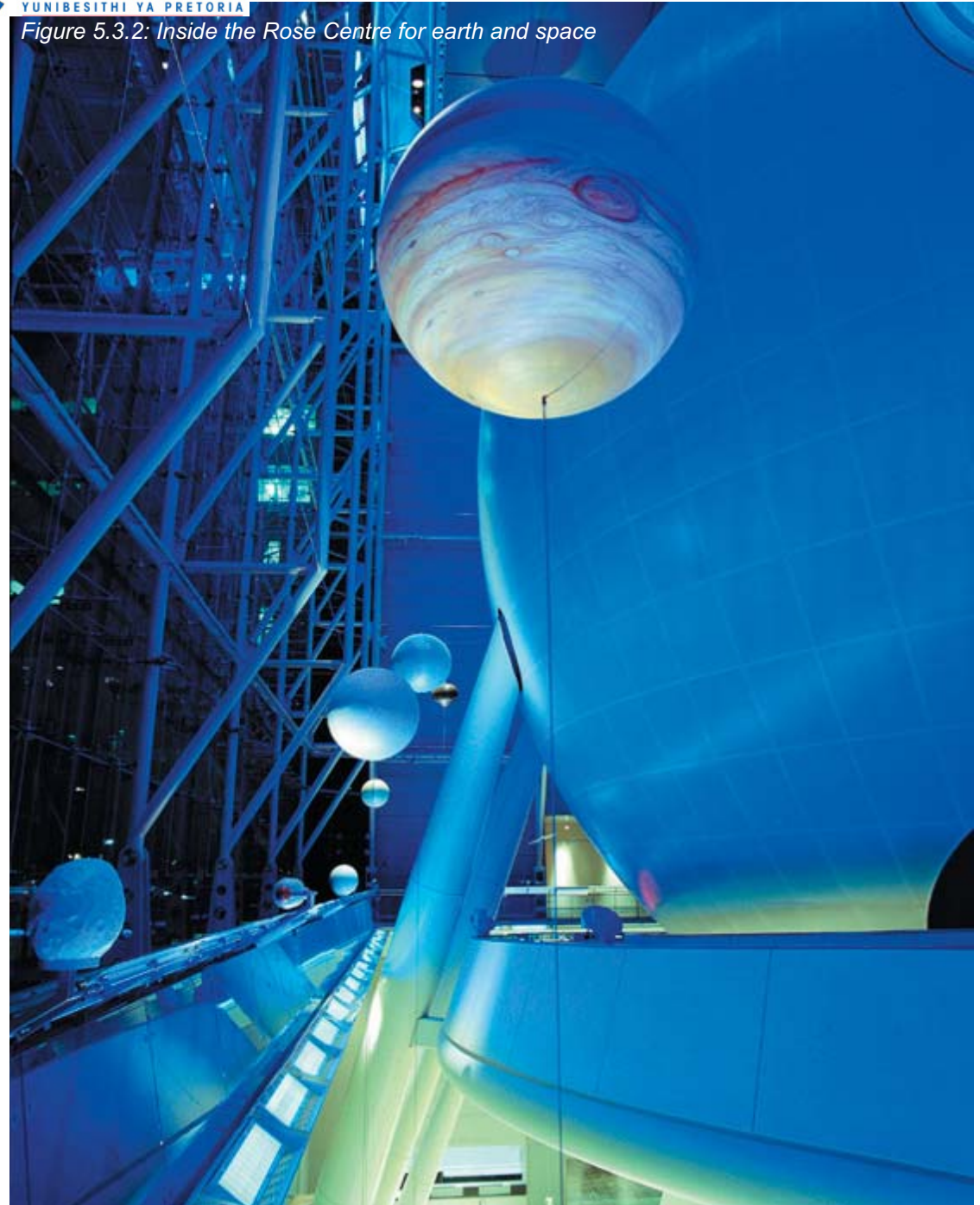

Figure 5.3.1: Street elevation of the Rose Centre for earth and space

architect describes this work as an 'architecture of interpretation'(Tyson quoted by Pearson, 2000: 105). This phrase implies a degree of engagement between architect and client and building and users, which invites multiple responses.

The sphere calls to mind the dome of the sky, the old Hayden Planetarium, the earth and heavenly objects (Pearson, 2000: 100). The design makes the science visible from the street as opposed to the traditional half-spherical planetarium that is merely an interior experience. The architects stated that the design does not pretend to be an extension of the 19th century building next to

it. The crisp lines of its cube, the exposed steel trusses and the otherworldly lighting of its interior, would clearly set the Rose Center apart from the rest of the museum. There is no doubt where the old ends and the new begins(Pearson, 2000: 100).

More than just a device to grab attention, a sphere helps bring scientific concepts to life(Pearson, 2000: 100). One of its important functions, for example, is to convey the varying scales of objects in the universe. Visitors walking along a gallery can compare a series of small objects to the giant planetarium sphere and get an idea of the size of the earth in relation to the sun or one star in relation to another. The sphere becomes a tool to

communicate science (Pearson, 2000: 105).

"It's a marriage of architecture and science. It's the universe as the architect's muse"

(Tyson quoted by Pearson, 2000: 105)

The 'cosmic pathway' has exhibits that narrate the 13-billion-year history of the universe from the big bang to the present day. Each step takes the visitor 75 million years down the timeline. By the end of this path mankind's time on earth is represented by the width of a human hair (Pearson, 2000: 105). In this pathway light is used 'to tell the story'. Light in the form of

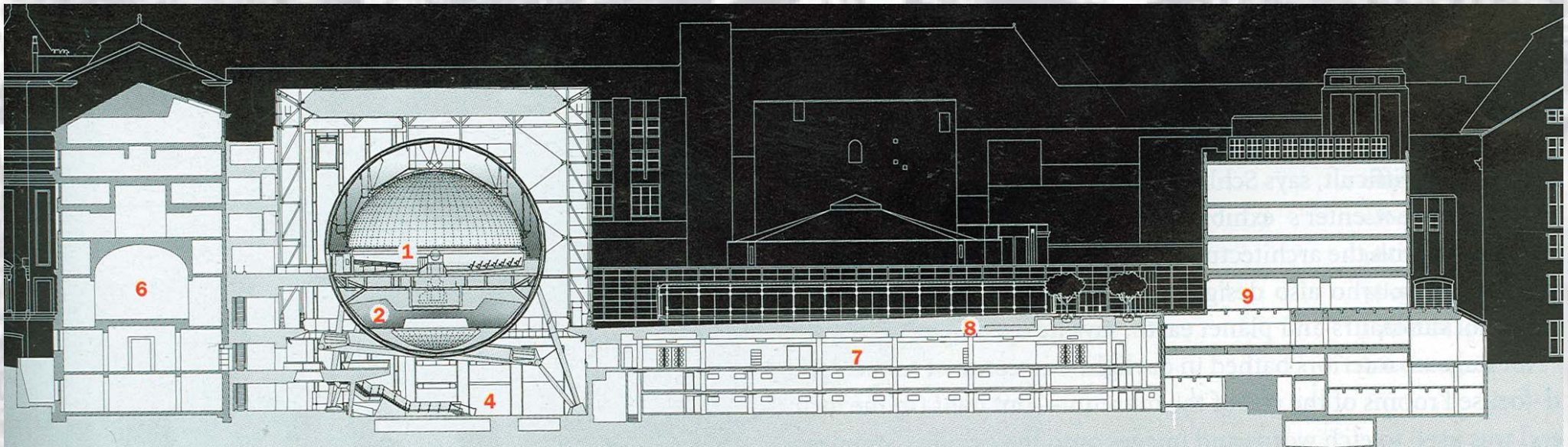
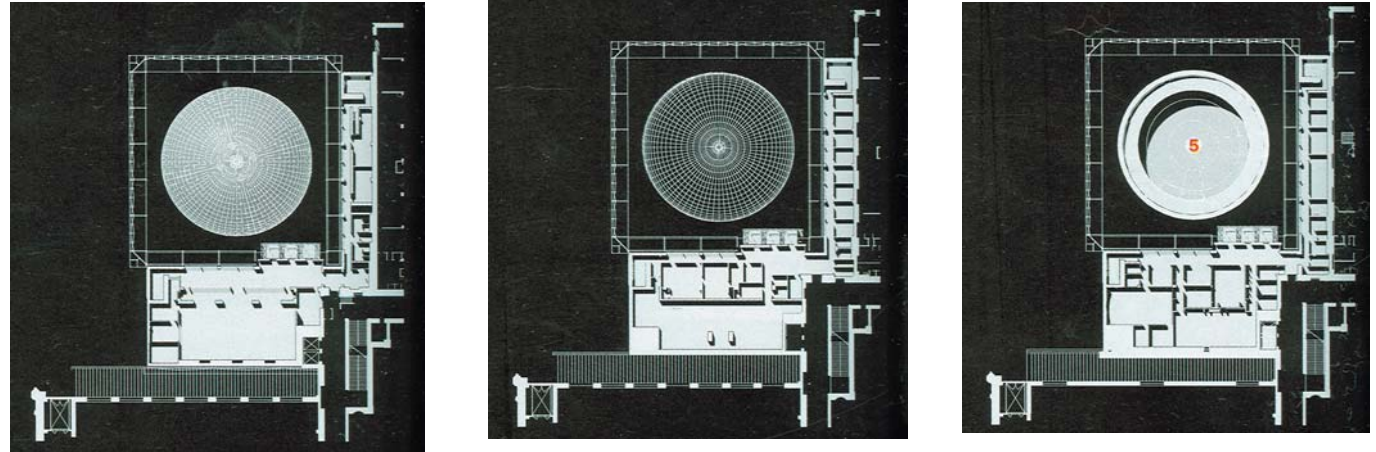

Figure 5.3.3: Longitudinal section



lasers is used to etch words and images onto the exhibits' stainless steel panels. Standing under the sphere, the visitor gets fragmented views of the Beaux-Art apartment building across the street (Pearson, 2000: 110).

The great mass of the planetarium sphere and planets hanging from the ceiling seem to deform the cubic volume and create a sense of animation that makes science come alive.



Figures 5.3.5 - 5.3.7: Plans

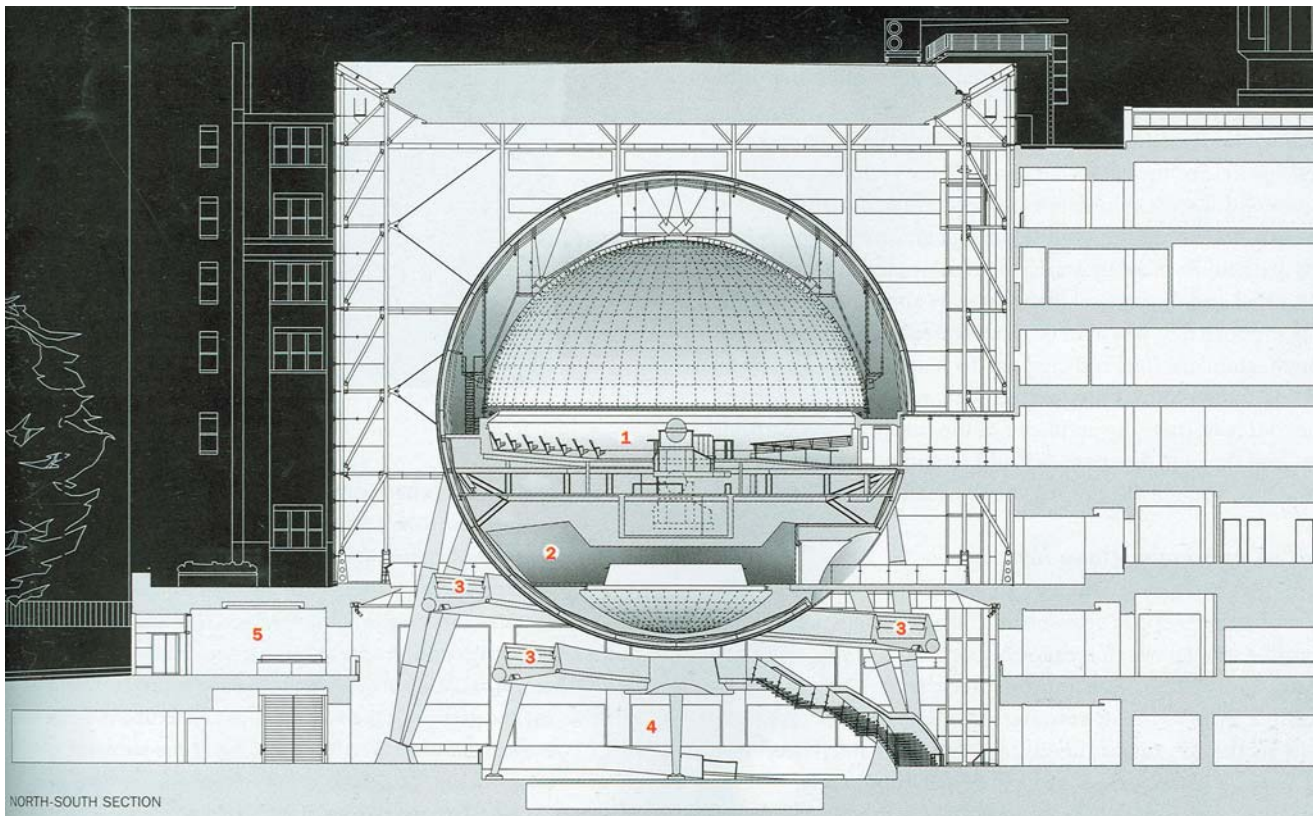

Figure 5.3.4: Section

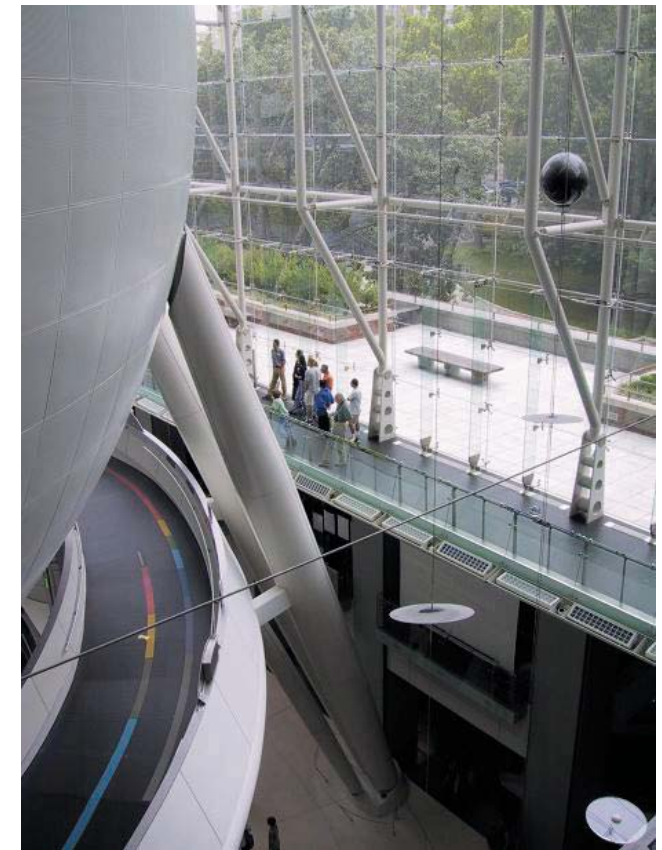

Figure 5.3.8

Design Influences

The main attraction of the facility is the planetarium. The exhibition spaces become part of the narrative of the cosmos. The design accommodates adult visitors but mainly focuses on large groups of children.

- The architecture is reduced to platonic solids.
- The building becomes a civic monument, with an iconic nature.
- The new structure is designed in its own right, not as an extension of the old museum.
- The interior of the new building allows a series of varying views of the old building.
- The architecture becomes a tool to communicate science.
- The main feature of the facility, the planetarium, becomes the nucleus of the design.
- Circulation in and around the facility becomes the key. The movement is directed in and around the nucleus in order to create different levels of spatial experiences.
- Instead of the new building merely becoming a stepchild of the museum, it rather becomes part of a seamless flow of spaces.

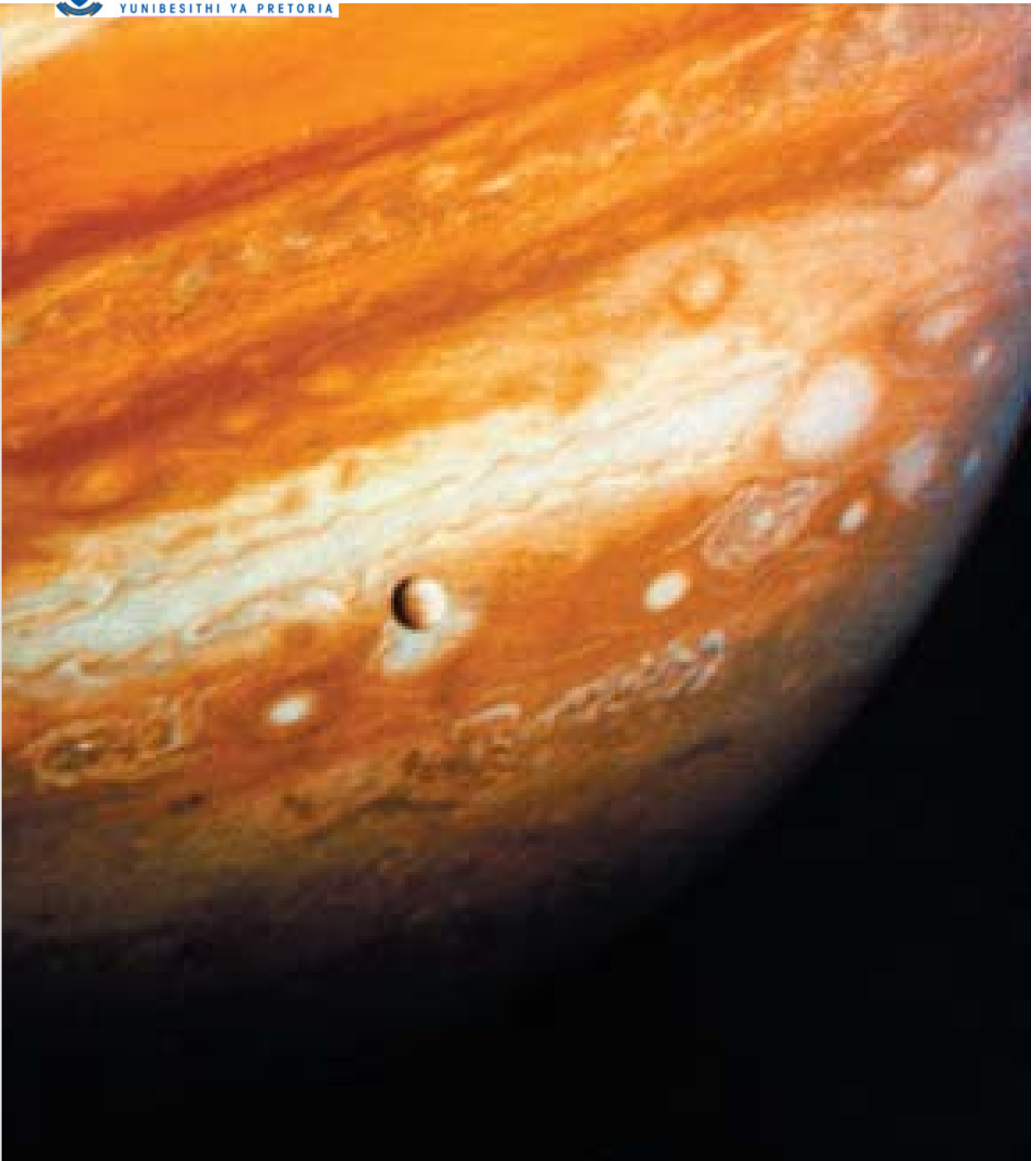

Figure 5.3.9

5.4 Origins Centre, Johannesburg, 2006, Mashabane Rose Architects

This museum dedicated to the origin of man comprises of two buildings and a central courtyard. Visitors enter the complex from the university side on the North, move through the courtyard and begin the narrative journey in the South building (www.mashabanerose.co.za/team.htm 06/04/07).

The architecture is stark, understated and silent. The heavy walls that create expanding and constricting cave-like interior volumes, allow the exhibition narrative to take centre stage. The building, still recognizable to most ex-WITS students as 'The Wedge', has shed its industrial history and has been redefined as a cultural container for the precious objects that aid the narrative. It sets the mood for its serious academic content (ibid).

The narrative experience is a rich feast of audio-visual material, artifacts and beautifully crafted contemporary artworks, with interactive touch screens and audio guides forming the basis upon which the journey is anchored. The text panels, showcases and displayed objects act only as sparks along the route that trigger ideas and introduce concepts to visitors. The stories, which range from ancient myths and legends to questions of identity and cultural influence and evolution make for a fascinating journey (ibid).



Figures 5.4.1 Internal view of the Origins Centre

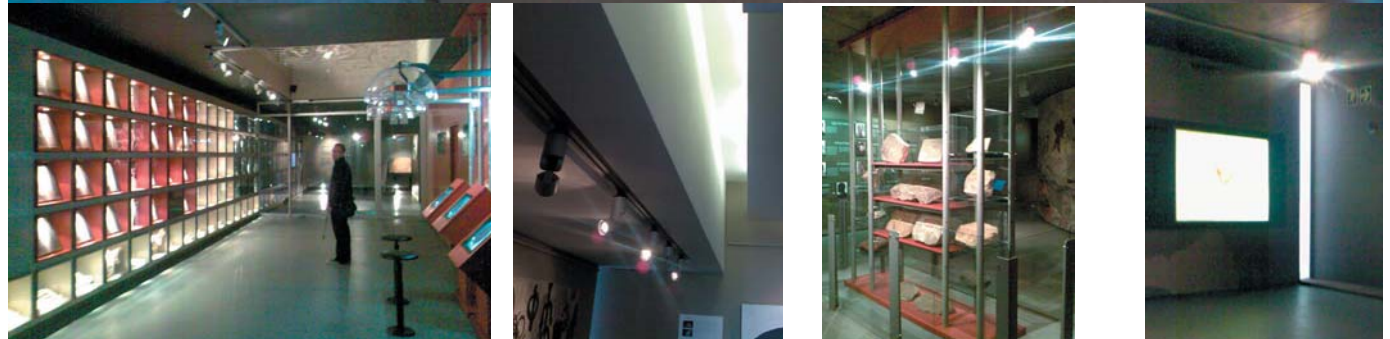

Figures 5.4.2 - 5.4.9 Exhibition space in the Origins Centre

Design Influences

- Base the exhibition route on a narrative which takes the visitor on a journey of exploration.
- Allow the exhibition narrative to take centre stage by creating architecture that is stark and understated. Make use of heavy walls that expand and create constricting cave-like interior volumes
- Consider the lighting as an integral part of the design narrative
- Use a variation of internal floor, wall and roof finishes, thereby creating a number of miscellaneous spatial experiences that responds accordingly to the narrative.

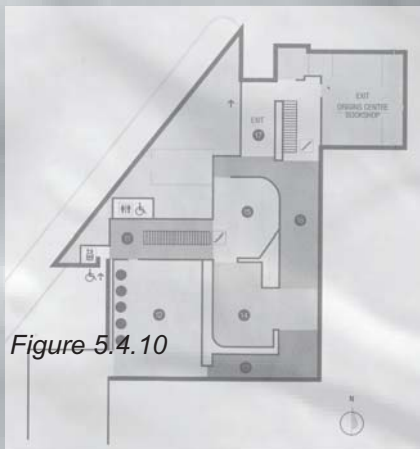

Figure 5.4.10

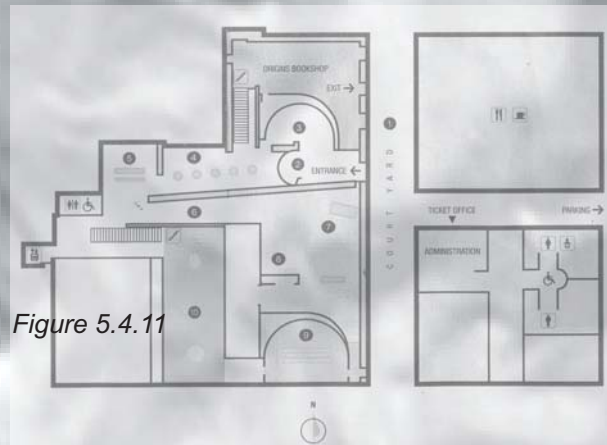

Figure 5.4.11

Conclusion

In this chapter four precedents are discussed that will be used as aids in the design process. Firstly, I explored the way that the design concept in Fabrica Benetton Art School is translated into architectural form. Secondly, I considered the way that the extension to the Reina Sofia responds to its urban context. Thirdly, I considered the Rose Center for Earth and Space as typological precedent in its dealings with the functional requirements of the facility and also in its use of architectural form to create architectural expression. Finally, I discussed the Origins Centre as a local precedent as a result of its use of a narrative in design and for its design of dark interior exhibition space.

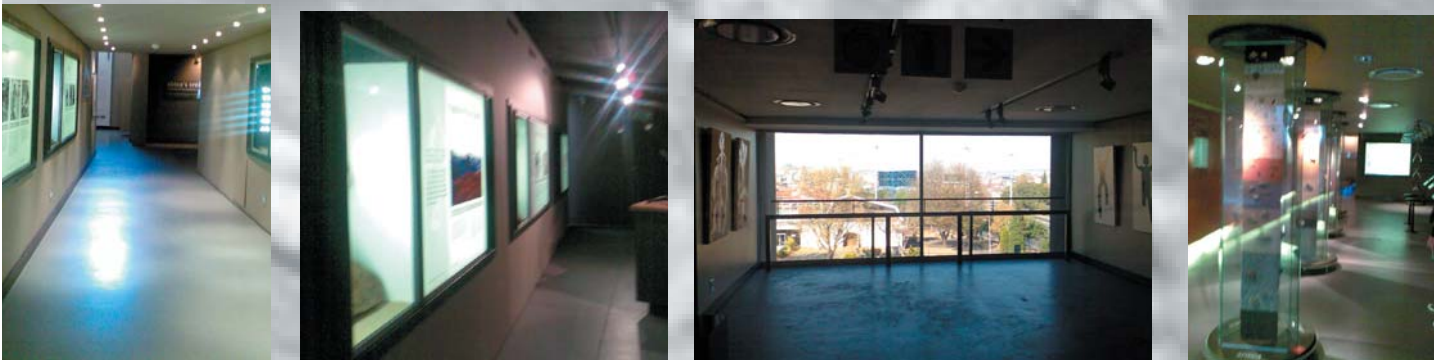
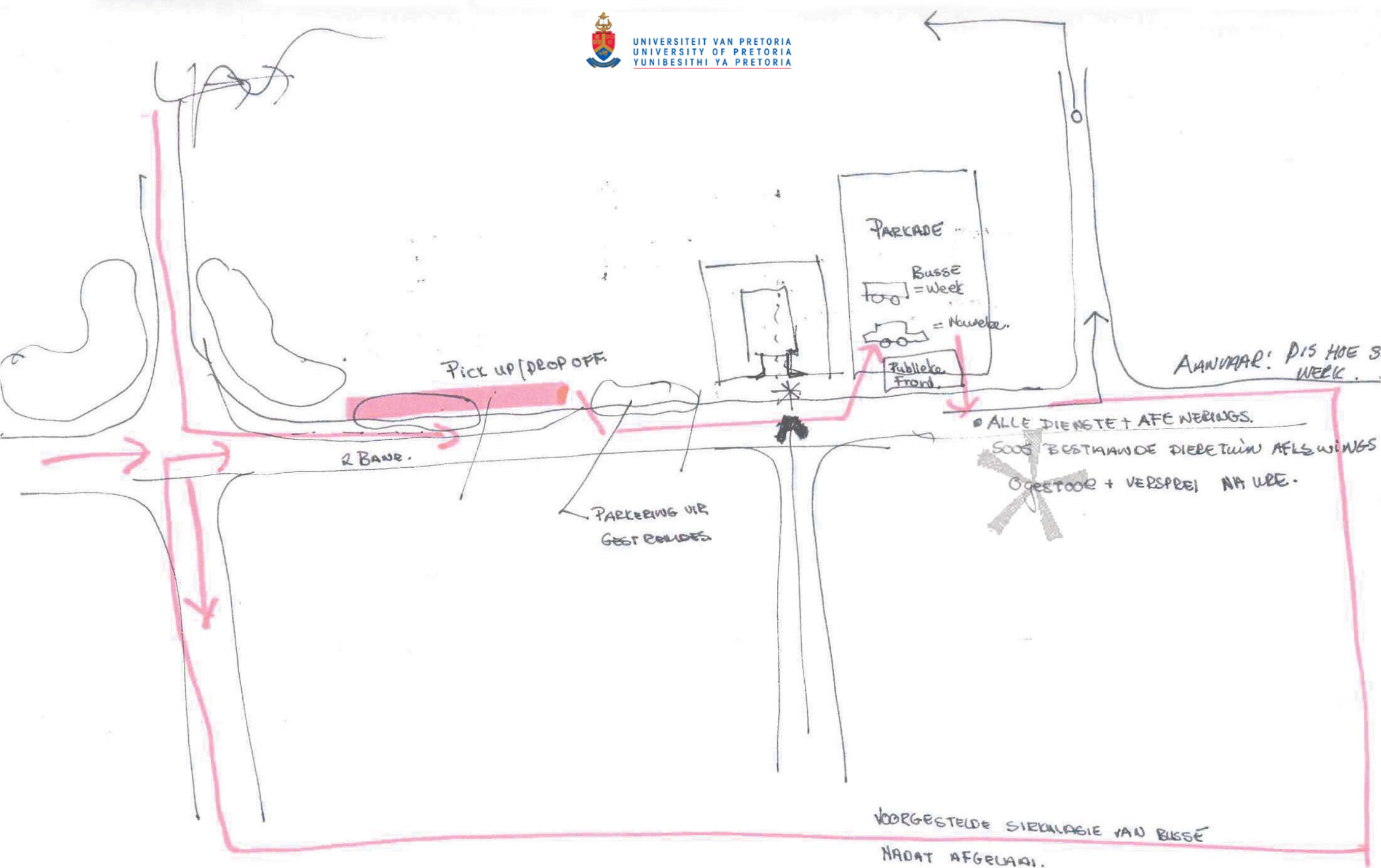

Figure 5.4.12



Introduction

The following chapter documents the process of the design of the astronomical centre and discusses the various factors which were taken into account to formulate the concept. It consequently discusses how the concept of the design was applied and developed.

Step 1: How to approach the ZOO TORE COURT as part of the northern gateway

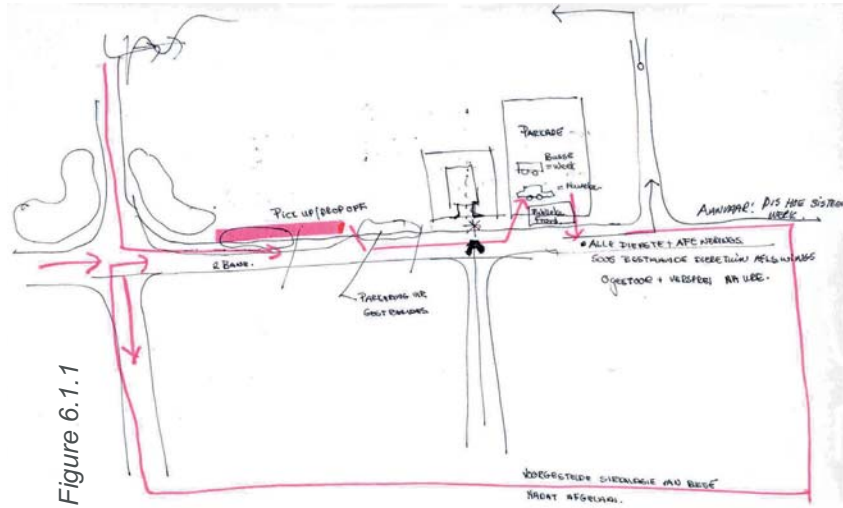

Figure 6.1.1

Working diagram 1: Vehicular movement

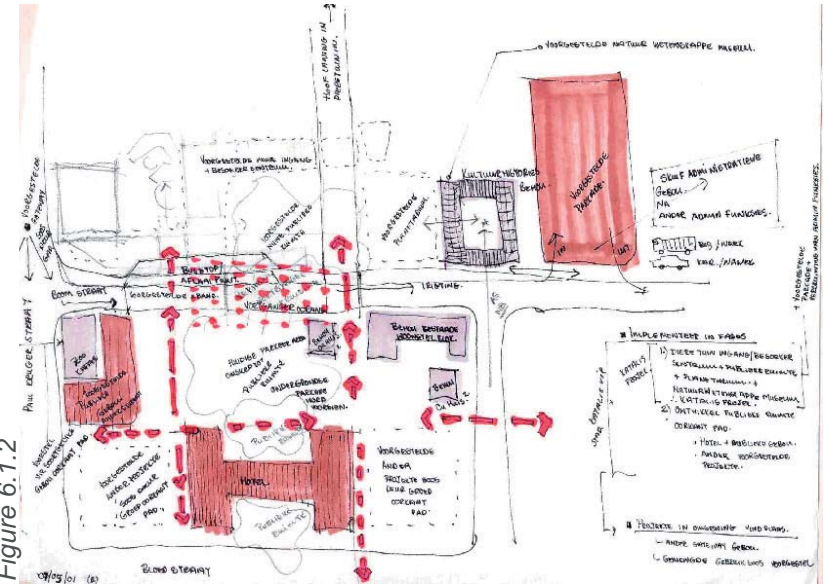

Figure 6.1.2

Working diagram 2: Pedestrian movement in the urban foyer

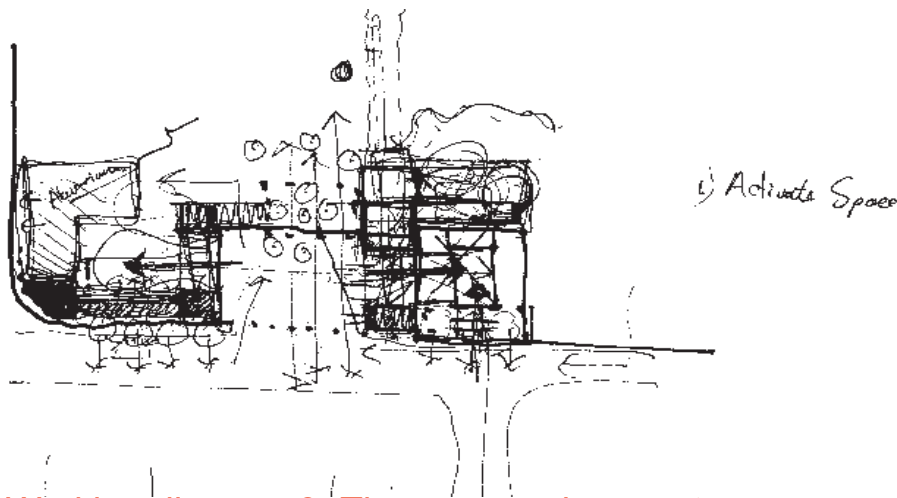

Figure 6.1.3

Working diagram 3: The proposed zoo entrance

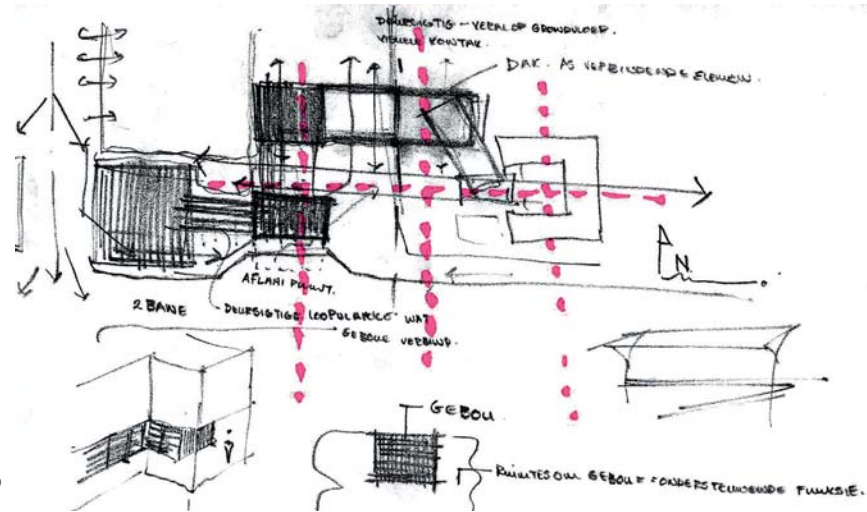

Figure 6.1.4

Working diagram 4: Pedestrian movement in the zoo forecourt

The Result: The Zoo Forecourt Proposal

Existing Zoological Gardens

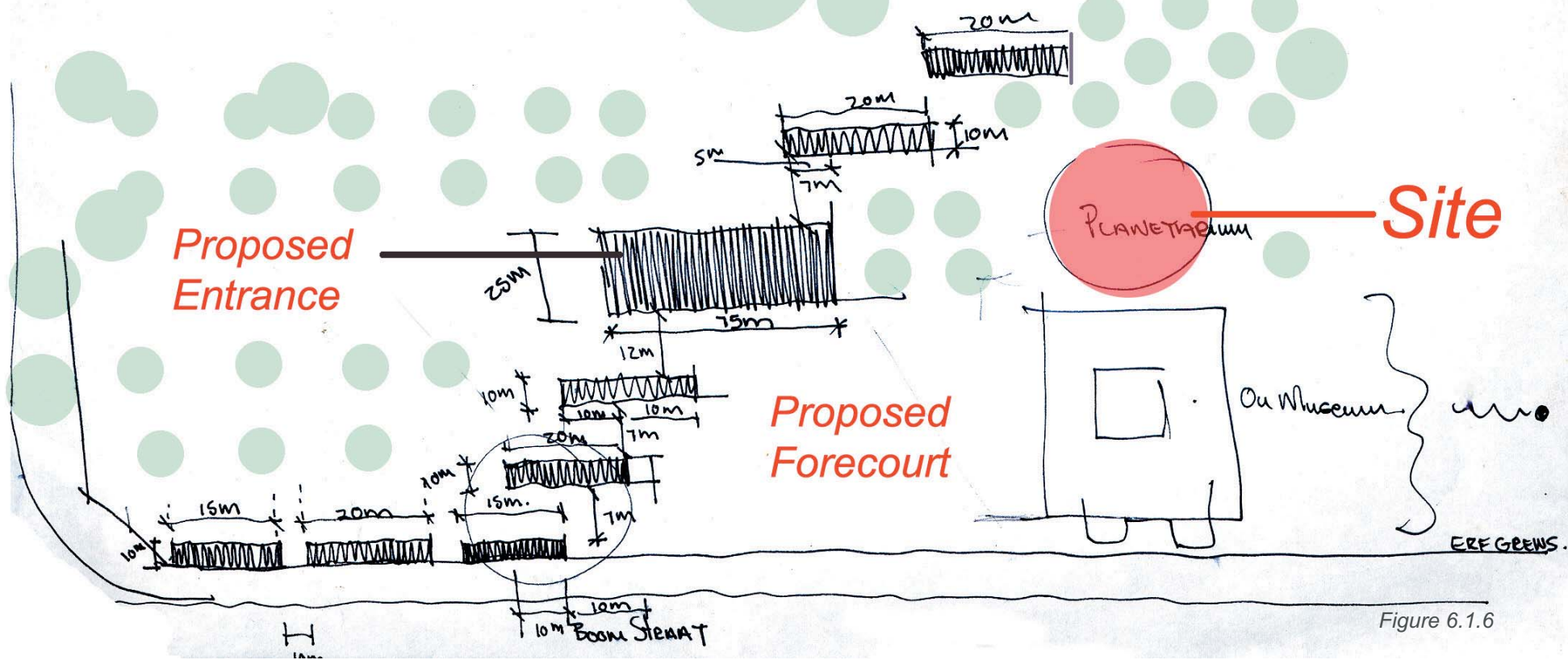

Figure 6.1.6

Step 2: How to deal with the *historical museum*



Figure 6.1.9

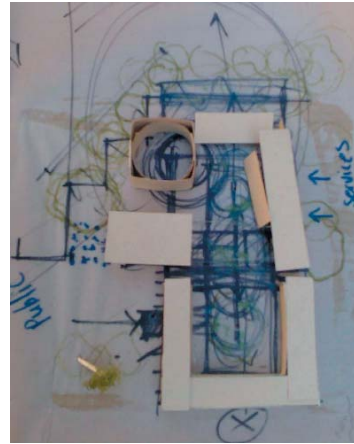

Figure 6.1.10



Figure 6.1.11

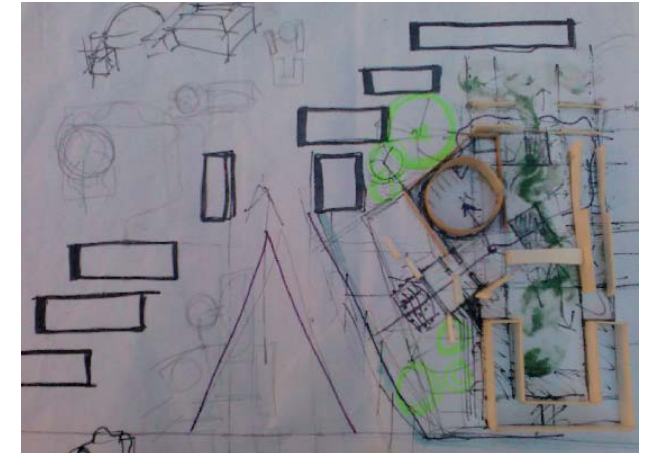
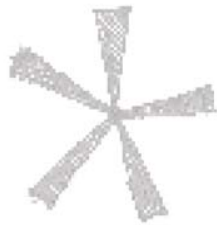

Figure 6.1.12



By considering the historical and cultural value of the neighboring Museum and the Zoo administration's current plans of renovating the building, it has been decided to *not physically touch the old building* but rather integrate it into the development by making use of a series of courtyard spaces that act as threshold spaces.

The Result



Figure 6.1.13

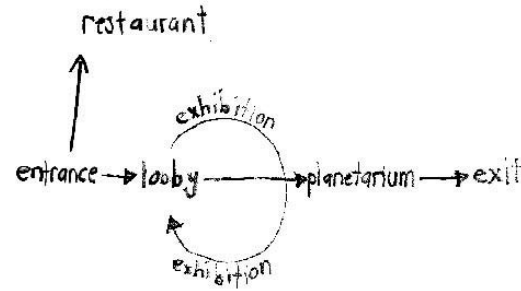

Figure 6.1.14

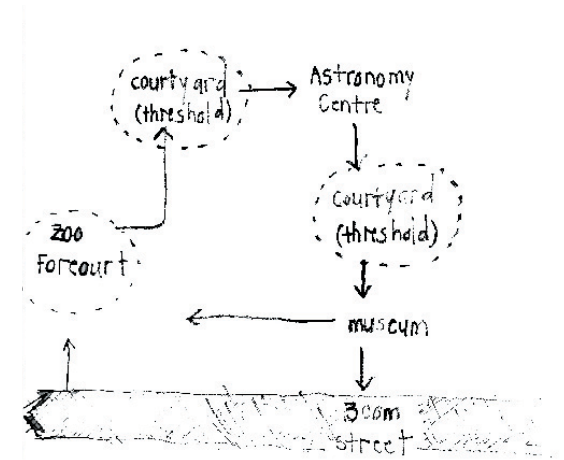

Figure 6.1.15

Step 3: Understanding the *movement*

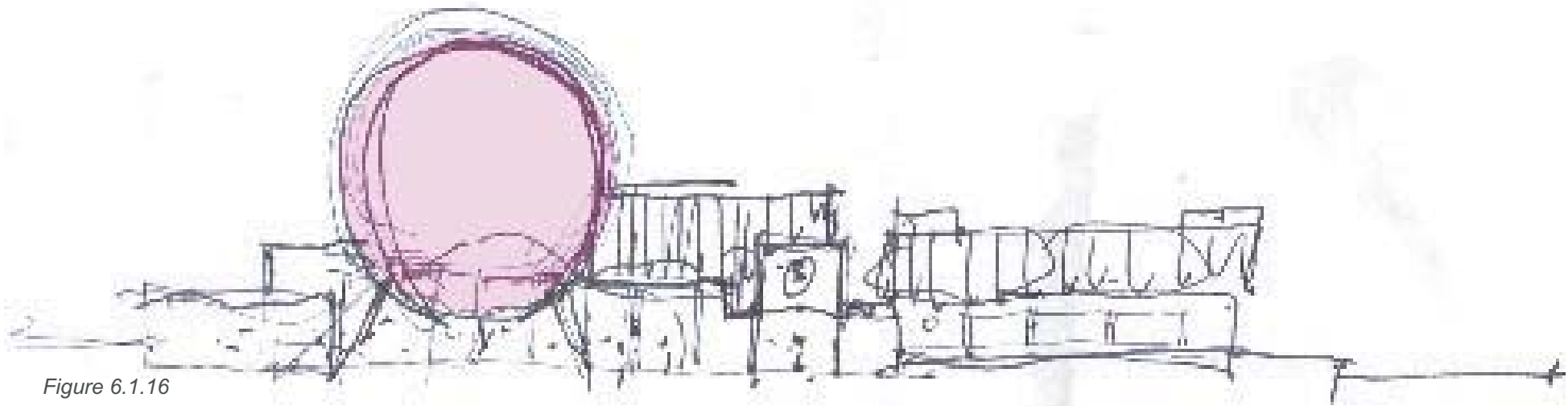

Figure 6.1.16

6.2 The *final concept* of the design of the Astronomy Centre

Design challenges and responses

As a result of the challenging site and unprecedented nature of project in the South African context, the following three determinants were considered to formulate the concept.

- The Context Study and Site Analysis
- The Precedent studies
- The Functional Requirements of the Facility



The urban foyer

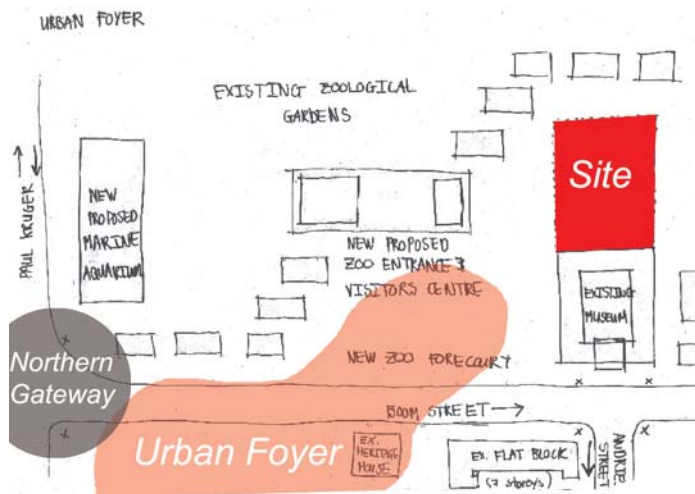

Figure 6.2.1

Site indicators

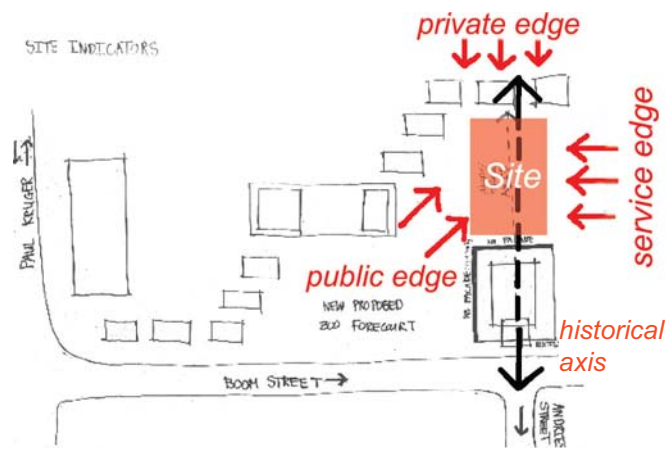

Figure 6.2.2

The nucleus

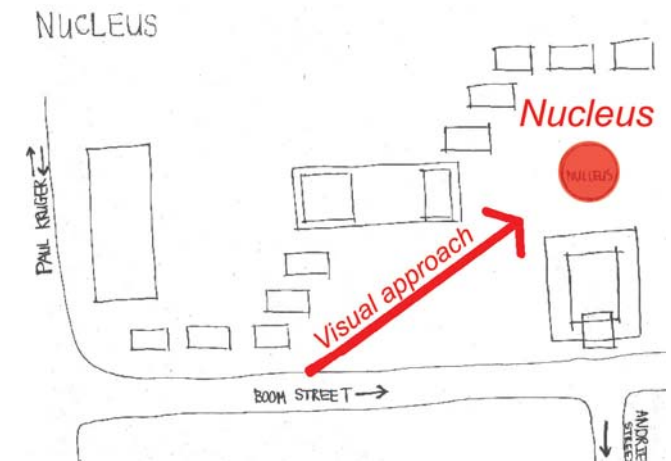
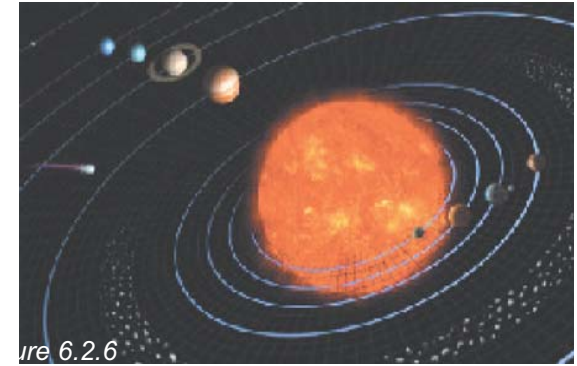

Figure 6.2.3



*Pedestrian approach:
'Route of Exploration'*

*Series of rooms become a
'sequence of events'*

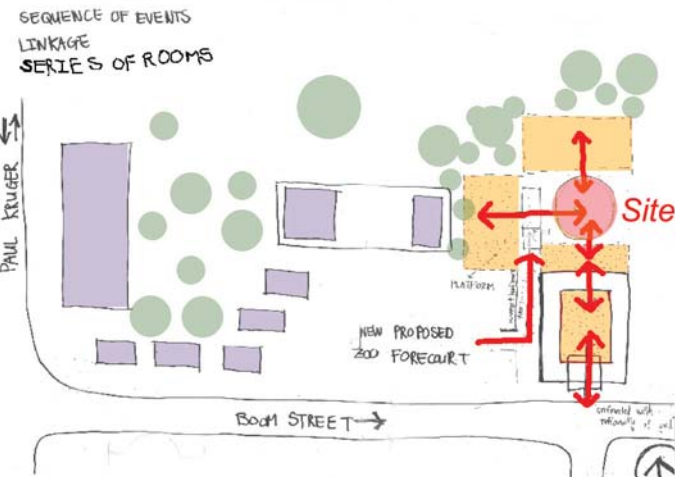

Figure 6.2.4

Figure 6.2.5

The Cosmic Pathway : Movement becomes the mediator between space and time

* Pearson argues that space and time are the essence of the universe (Pearson 2000:110). In order to communicate this concept the visitor is led through a series of spaces that represents a series of cosmological concepts. The main objective of the design therefore becomes the development of a cosmic pathway which communicates the mysteries of the universe.

The concept that informed the movement route is that of objects orbiting around the nucleus. By taking advantage of the expression of architectural form of the sphere, the visitor is led on a journey in which different views of the nucleus will be experienced.

The Narrative

In developing the narrative, the study on the existential expressive qualities of architectural form, discussed in the theoretical investigation, was considered to create a sequence of spaces that communicates concepts of the cosmos.

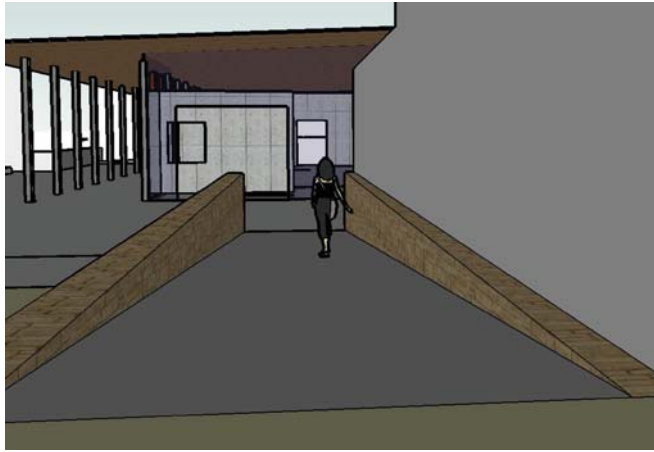

Moment 1: The approach



Moment 2: The suggestion



Moment 3: Descent into solidity, entering earth

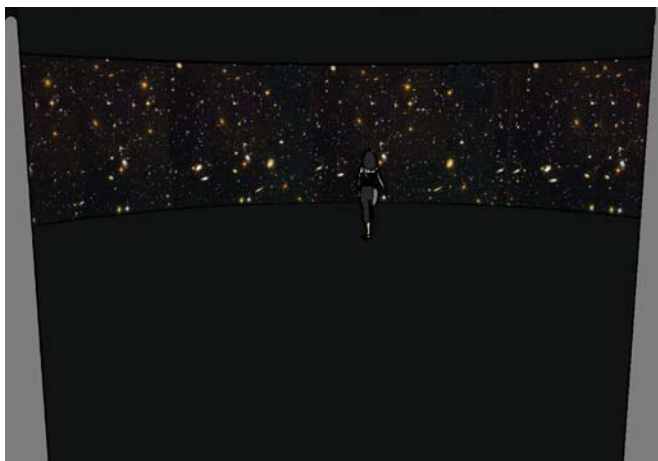

Moment 4: Explosion, the big bang

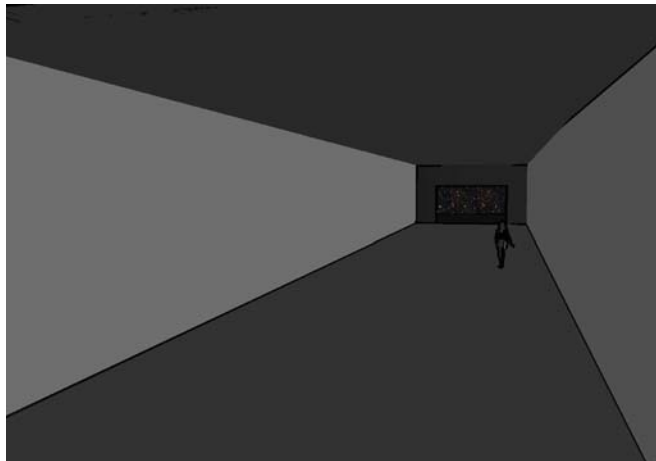

Moment 5: Expansion, the universe

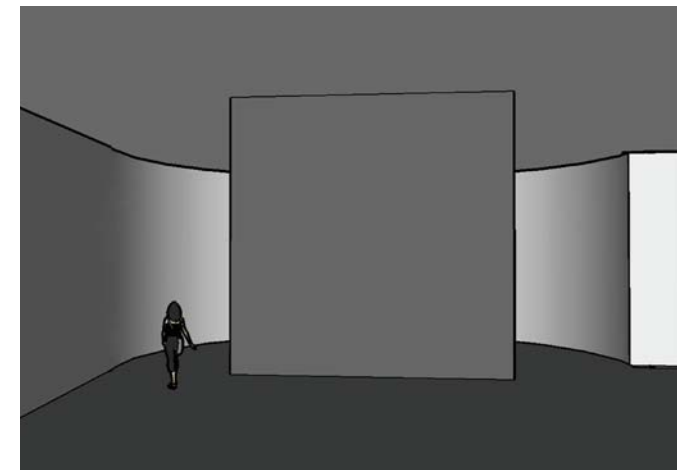

Moment 6: Infinity

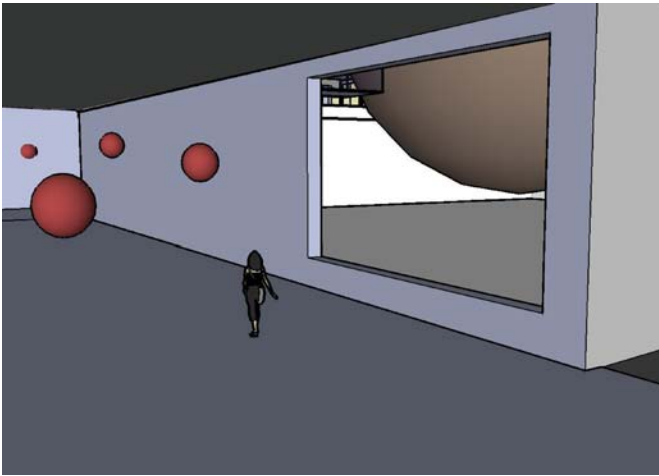

Moment 7: Scale of celestial objects



Moment 8: Space contraction



Moment 9: Ascend to earth surface



Moment 10: Entering sky



Moment 11: Entering nucleus



Moment 12: Visual infinity

6.3 Design development

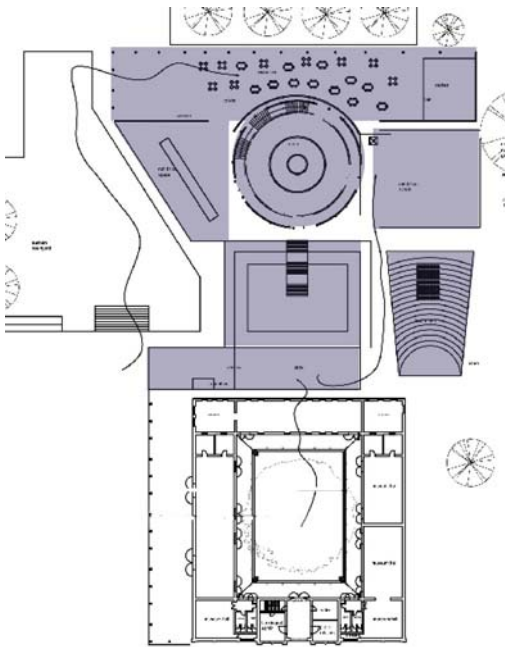

Figure 6.3.1

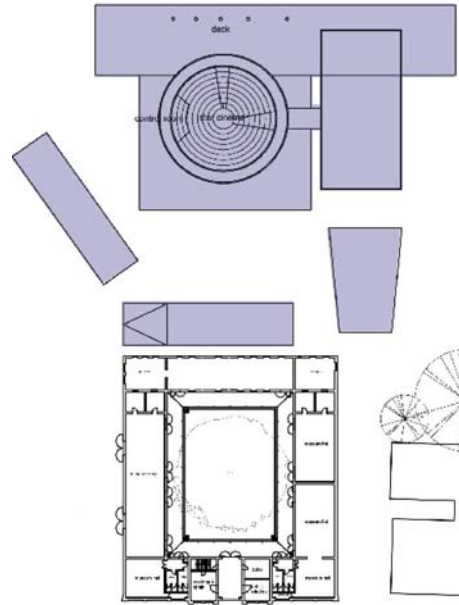

Figure 6.3.2

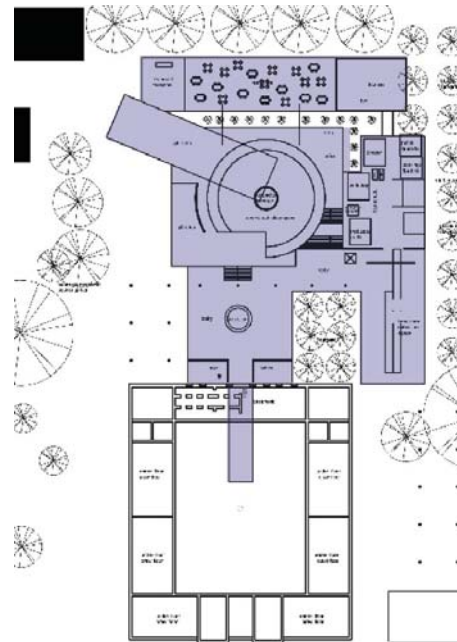

Figure 6.3.3



Figure 6.3.4

The entrance of the new structure becomes the link between old and new



Create a central courtyard

Discard secondary auditorium, condense design

Discard diagonal lines in plan

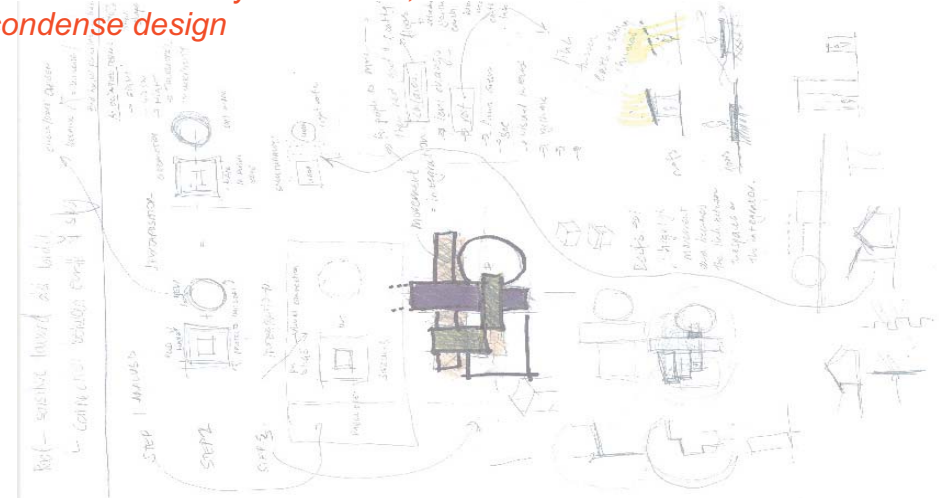

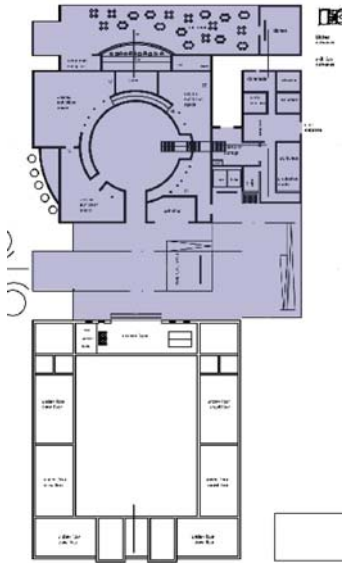

Figure 6.3.5

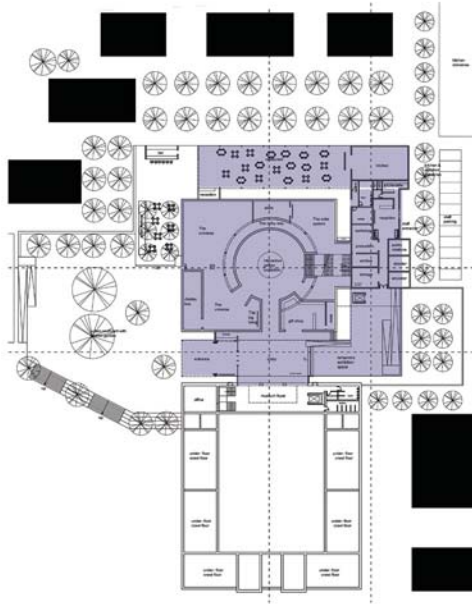

Figure 6.3.6

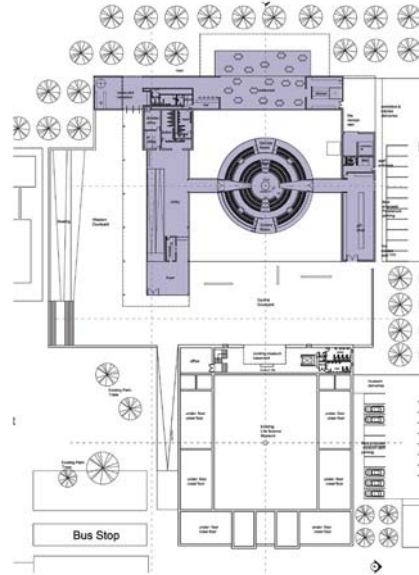

Figure 6.3.7

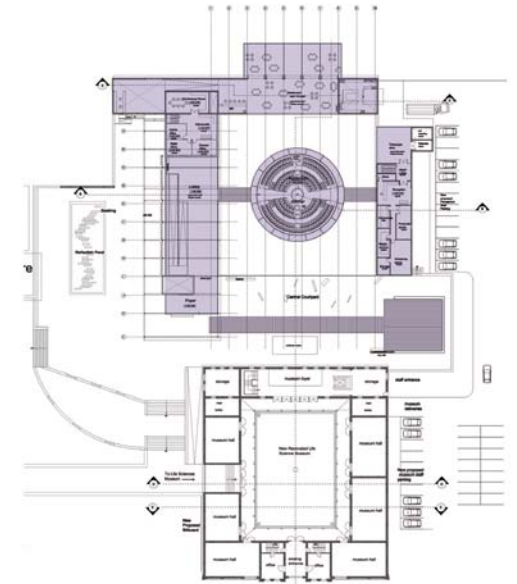
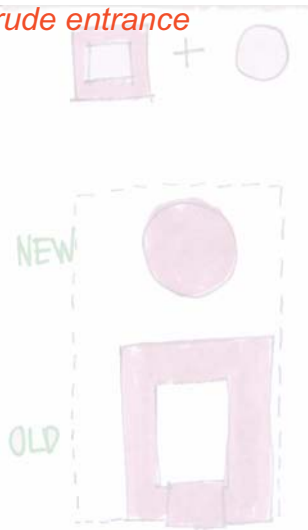
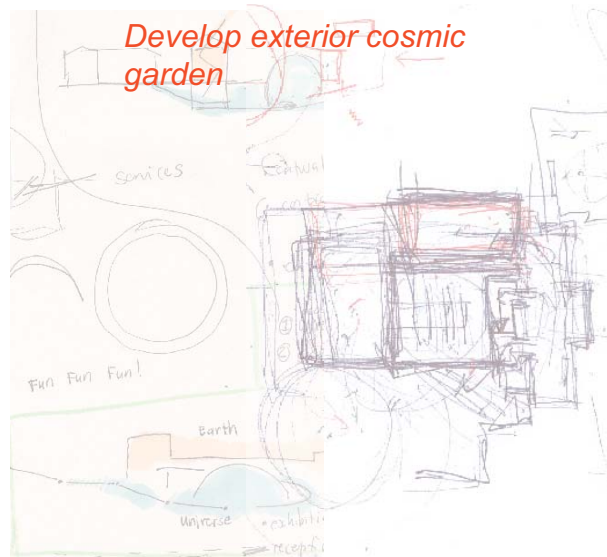

Figure 6.3.8

Extrude entrance



Develop exterior cosmic garden



Remove the structure of the new facility from the old facility, move the entrance to the western facade. Move cosmic garden into interior of facility

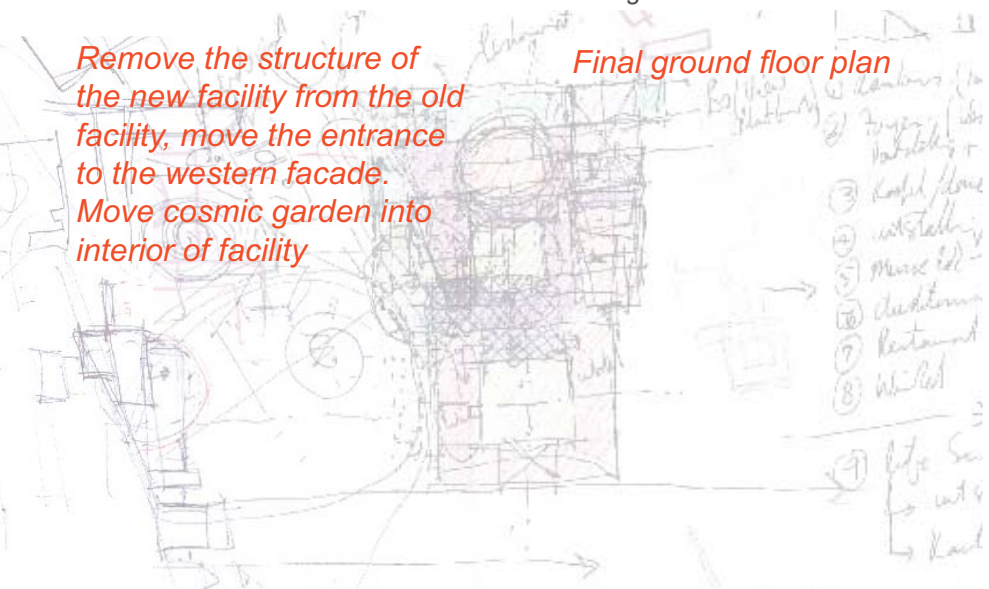

Final ground floor plan

- ① Auditorium (to be removed)
- ② Function room
- ③ Roofed floor
- ④ installation
- ⑤ Mess hall
- ⑥ Auditorium
- ⑦ Restaurant
- ⑧ Workshop
- ⑨ Life Sciences
- ⑩ Library

The building becomes a path of discovery, problem solving becomes the adventure. The following are the interactive features incorporated into the design whereby the visitor learns by means of involvement :

Figure 6.2.10

- 1) The 13-billion year age of the universe is communicated by the length of the exhibition journey. Along the path it is indicated how many years have gone past. At the end of this pathway the age of mankind is represented by the width of a hair (figure 6.2.13).
- 2) The solar courtyard will be an interactive playground, accommodating object that teaches the user about scientific concepts (figures 6.2.7 & 6.2.8).
- 3) The solar system scale walkway is an interactive educational tool teaching the user about the scale of the solar system. The walkway is a route through the zoo that is proposed to be lit at night. It is designed relative to the nucleus of the design, representing the sun (figure 6.2.15).
- 4) The star stops are marked areas on the floor in the temporary exhibition space. These areas have corresponding skylights from where certain specific southern hemisphere constellations can be seen on the first day of every month at 8pm (figure 6.2.14).



Figure 6.2.7



Figure 6.2.8



Figure 6.2.9

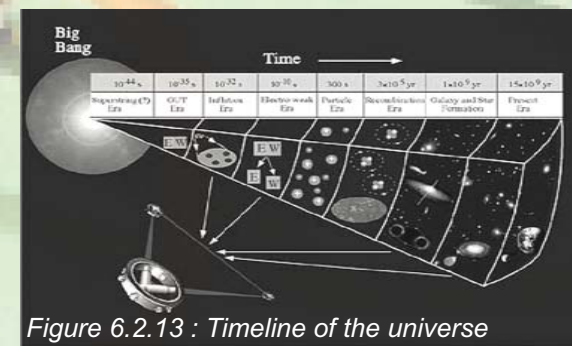

Figure 6.2.13 : Timeline of the universe

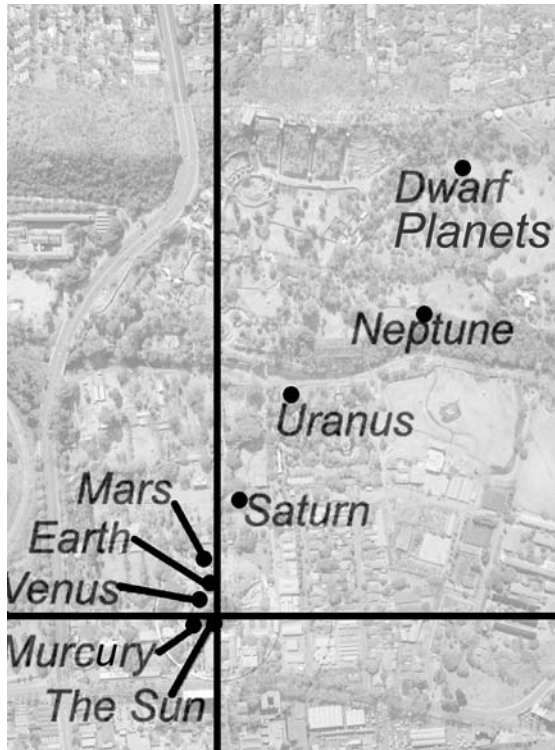

Figure 6.2.15 The solar system scale walkway



Figure 6.2.14 Diagram of a star stop

Conclusion

In this chapter the process of the design of the astronomical centre and the various factors which were taken into account to formulate the concept were considered. It consequently discussed how the concept of the design was applied and developed.



UNIVERSITEIT VAN PRETORIA
UNIVERSITY OF PRETORIA
YUNIBESITHI YA PRETORIA



UNIVERSITEIT VAN PRETORIA
UNIVERSITY OF PRETORIA
YUNIBESITHI YA PRETORIA

Technical Investigation

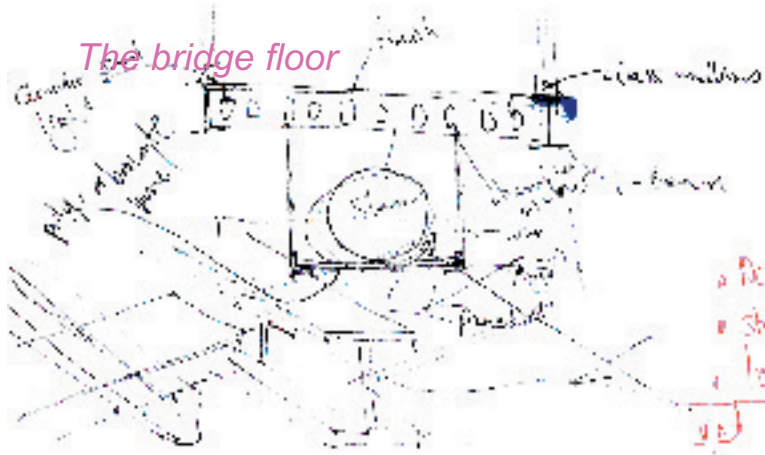

The bridge floor

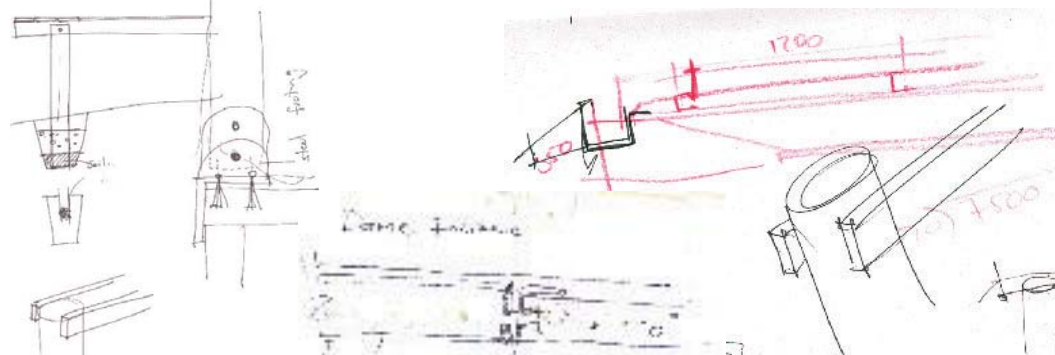

The sphere entrance

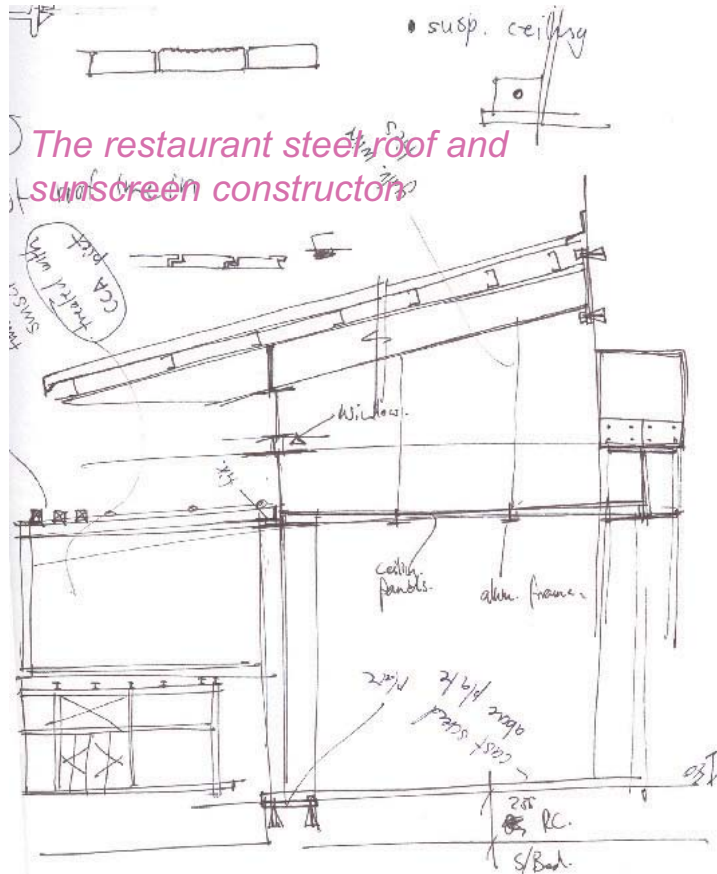

The restaurant steel roof and sunscreen construction

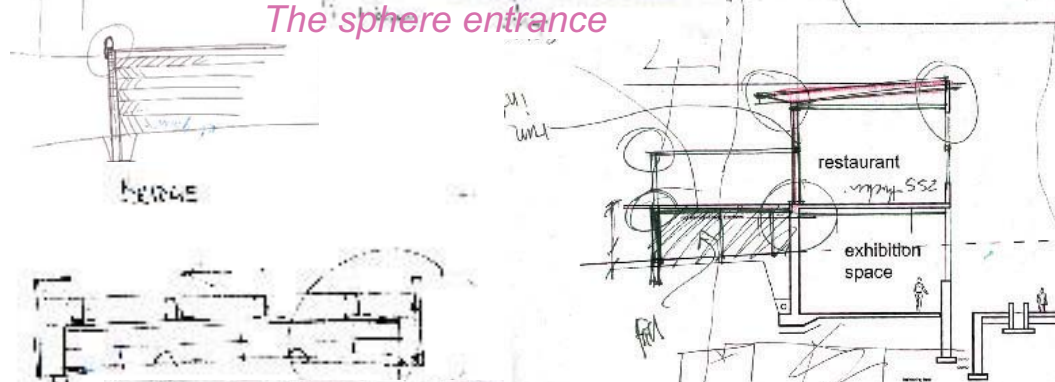

The bridge roof

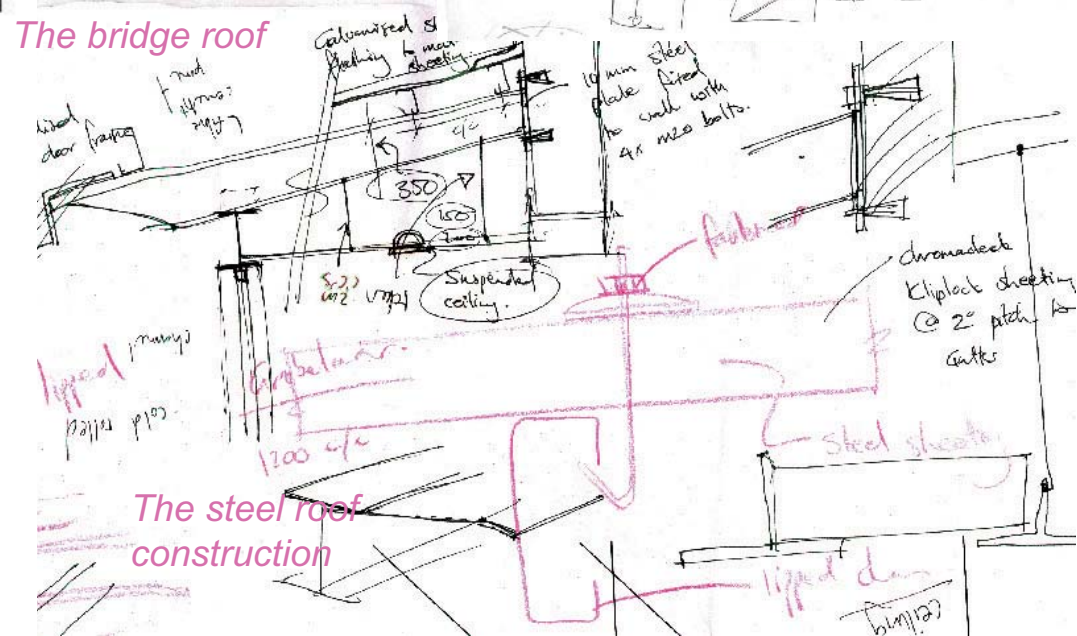

The steel roof construction

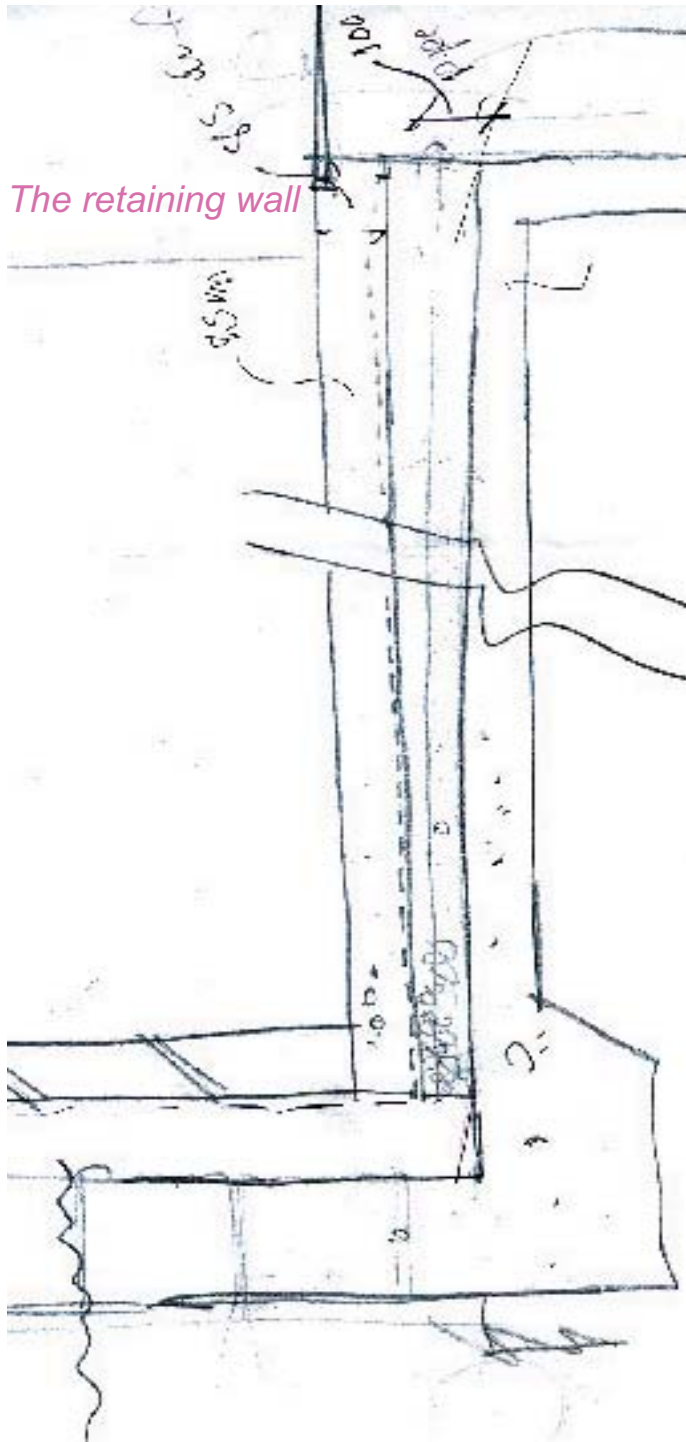

Introduction

The following chapter is supplementary to the set of drawings to motivate the decisions made with regard to the technical resolution of the astronomy centre. It deals with the most important technical issues raised by the design.

7.1 Structure

The primary structure of the building is a reinforced concrete structure consisting of a column, beam and slab system. The portion of the building that is situated under the natural ground level is supported by a reinforced concrete cavity wall system. The portion of the building that is located above the ground consists of two structural systems. In the reception and restaurant spaces the building is supported by a stainless steel structure. The administration block is constructed of load bearing masonry walls.

Phases of the construction of the sphere

Phase One

Construction of the four reinforced concrete columns



Figure 7.7.1



Figure 7.7.2

Phase Two

Casting of the first reinforced concrete floor slab

Phase Three

Construction of the reinforced concrete compression ringbeam

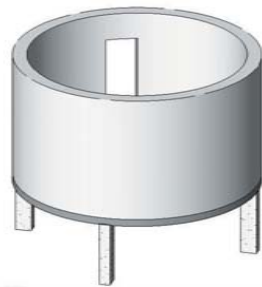

Figure 7.7.3

Phase Four

Construction of the reinforced concrete diagonal fins and casting of the second reinforced concrete floor slab

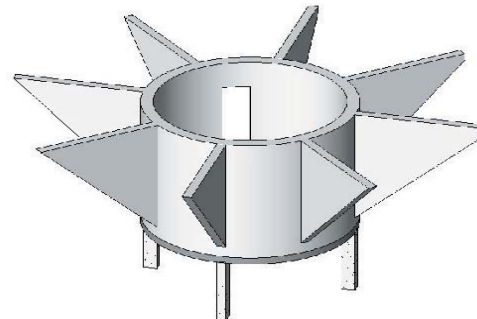

Figure 7.7.4

Phase Five

Attaching the circular steel trusses to the reinforced concrete compression ring (below) and to a steel tension ring (above)

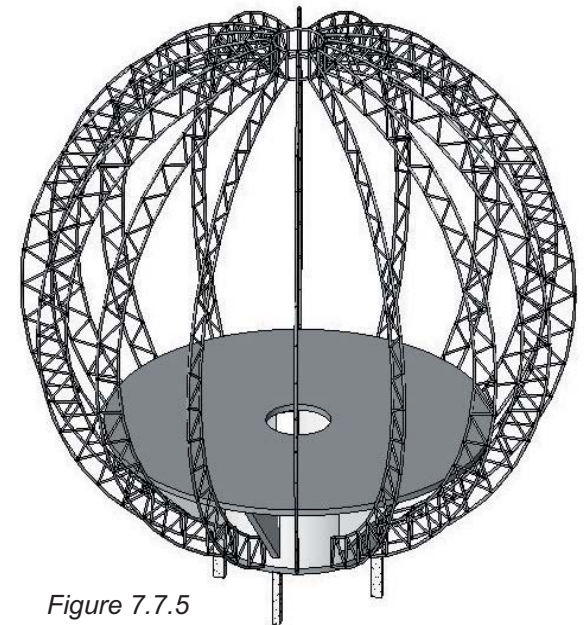

Figure 7.7.5

Phase Six

Attaching the circular lipped channel steel purlins to the outside of the trusses

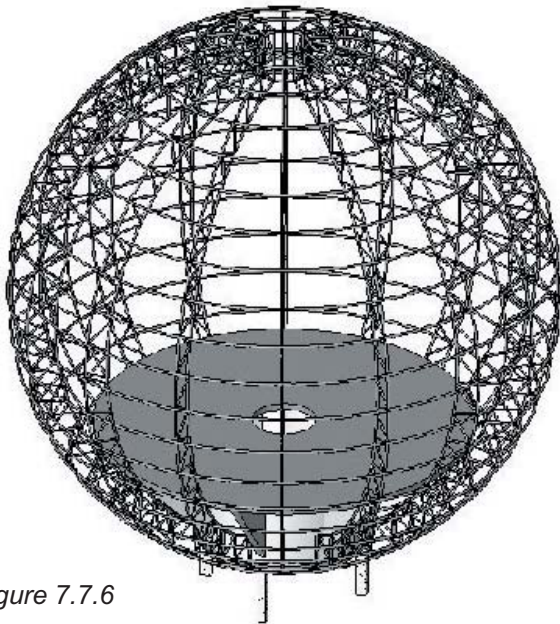

Figure 7.7.6

Phase Seven

Attaching the circular lipped channel steel purlins to the inside of the trusses

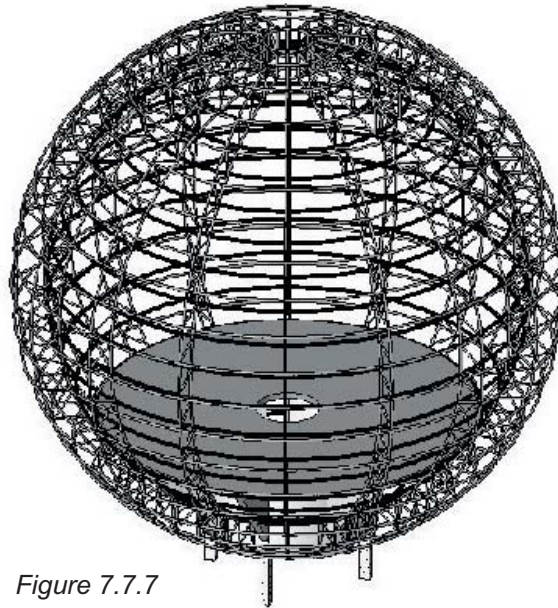

Figure 7.7.7

Phase Eight

Attaching 3 x 3mm plywood to the purlins, covered with felt and cladded with copper sheeting. Inserting the perforated aluminium display screen with sound absorbant panels to the interior purlins

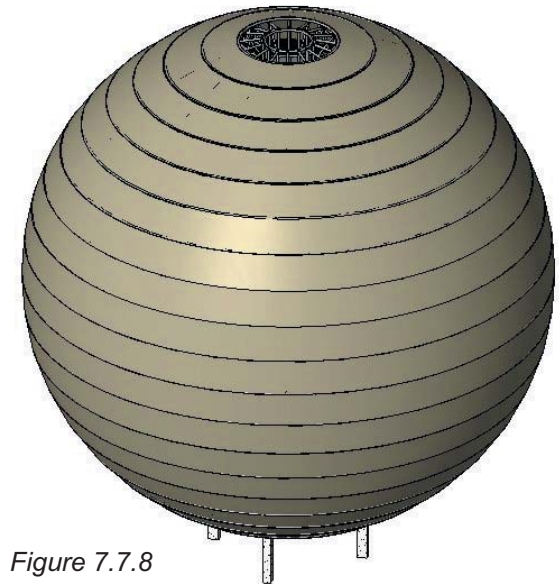

Figure 7.7.8

7.2 Skin

The skin of the building consists of a number of materials. The reception and restaurant areas are glazed, the services block on the western façade is constructed of off shutter concrete and the ticket box is enclosed by a light transmitting fibre-optic concrete wall. The dome is clad with copper sheeting. All glazing to be installed according to Part N of the SABS(0400).

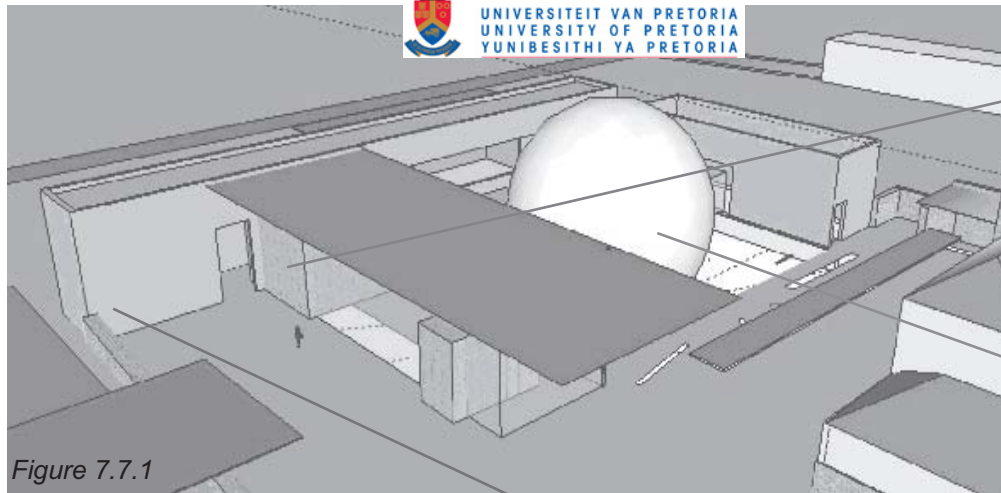

Figure 7.7.1

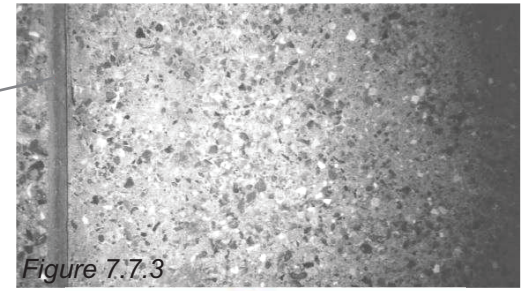

Figure 7.7.3



Figure 7.7.4



Figure 7.7.5

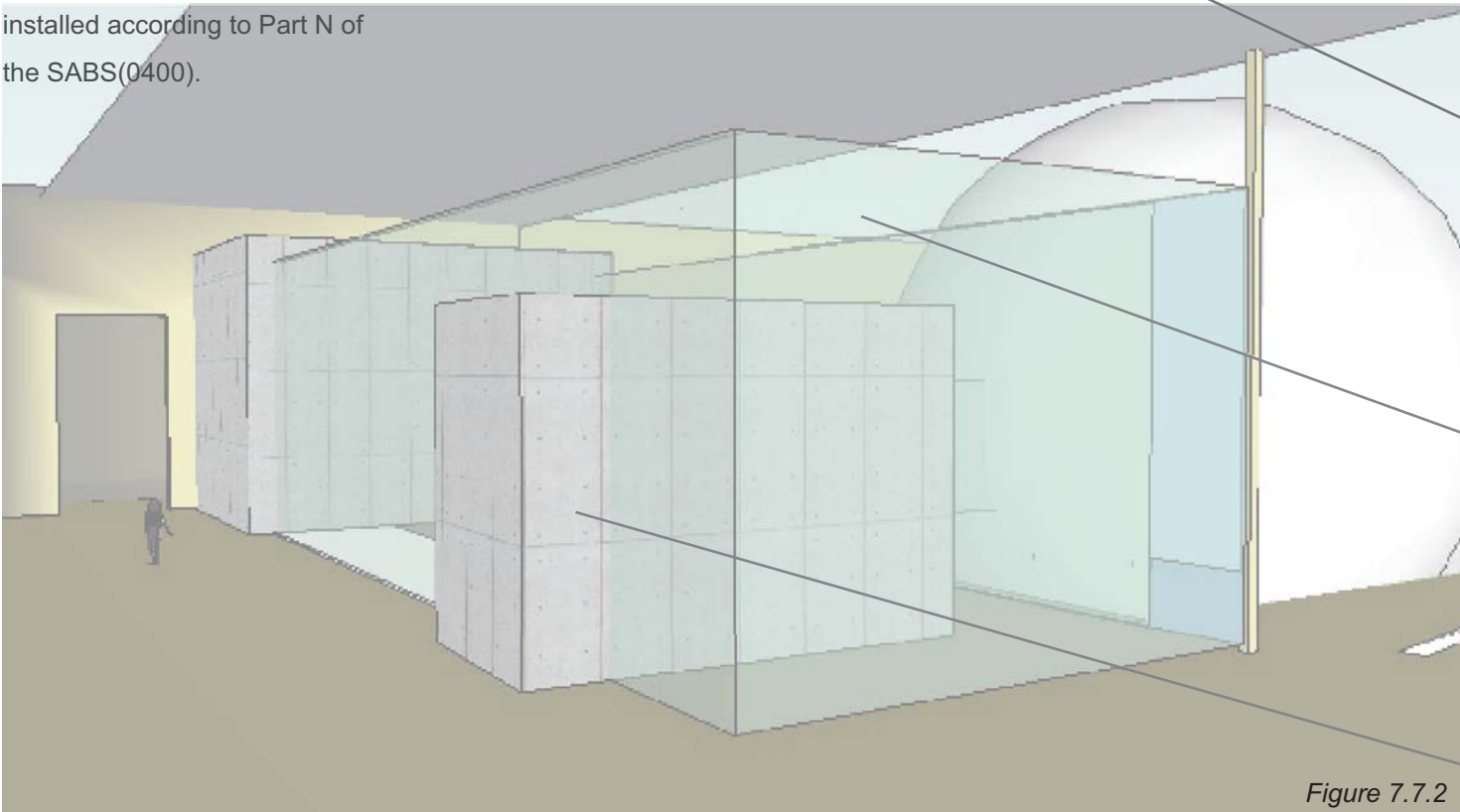

Figure 7.7.2



Figure 7.7.6



Figure 7.7.7

7.3 Fire

The following guidelines as dictated by the National Building Regulation (part T of SABS 0040) have been considered :

- Life safety and provision for escape
- Minimize the spread of fire both within the structure and from building to building
- Detection and prevention of the spread of smoke and heat
- Provision for detection devices.

Escape routes do not exceed 45m and fire extinguishers are provided at 30m intervals. Fire equipment will form part of the 'building management system' and a sprinkler system and smoke detectors will be installed in the applicable areas. The building is smoke free in all internal areas.

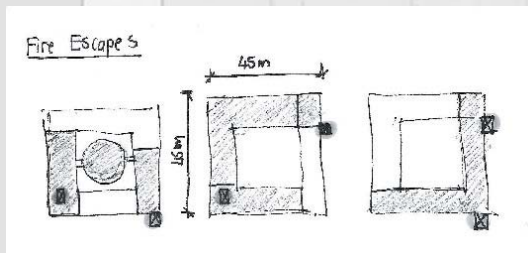

Figure 7.3.1 Diagram of fire escapes



Figure 7.3.2

Problems caused by temperatures in this area : high temperatures, high diurnal temperature ranges, intensity of precipitation at times and inefficient dispersal of air pollution. The area is characterised by generally high temperatures and relatively high humidity.

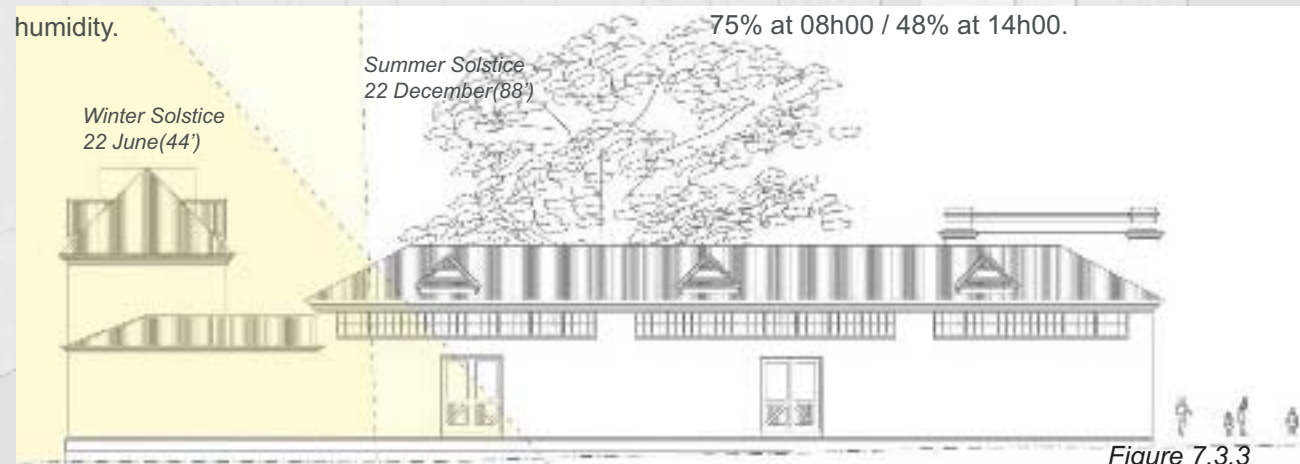

Figure 7.3.3

7.4 Natural determinants

Wind Direction: North east in the morning, back north west in the afternoon. Strength 3,9m/s. Daspoort ridge slows down the morning winds, afternoon winds stronger as they are funnelled through the poort ridge. Thunderstorms are accompanied by turbulent wind patterns.

Geology shale and quartzite.

Rainfall is Seasonal(in summer), average 741mm per year. Thunderstorms can cause up to 90 – 100mm/hr.

Hailstorms are fairly common.

Average annual **cloud cover** : 33%, varying between 13% in July and 54% in December.

Humidity : monthly average : min of 57% at 08h00 / 29% at 14h00 in September to a max of 75% at 08h00 / 48% at 14h00.

7.5 Orientation and solar control

The entrance of the facility faces west creating direct access and a visual link from the zoo forecourt. The restaurant opens up to the north unto a deck facing the zoo. To minimise direct sunlight from above the deck is equipped with a timber sunscreen. The entrance and gift shop buildings have glazed skins with vertical louvre systems that control direct solar radiation on their western façades.

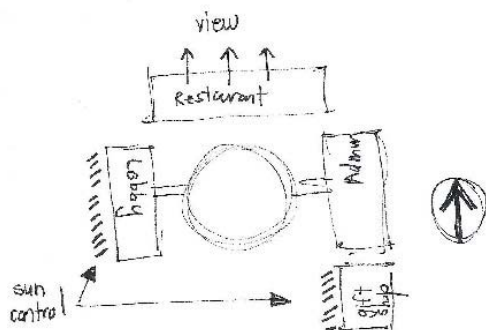
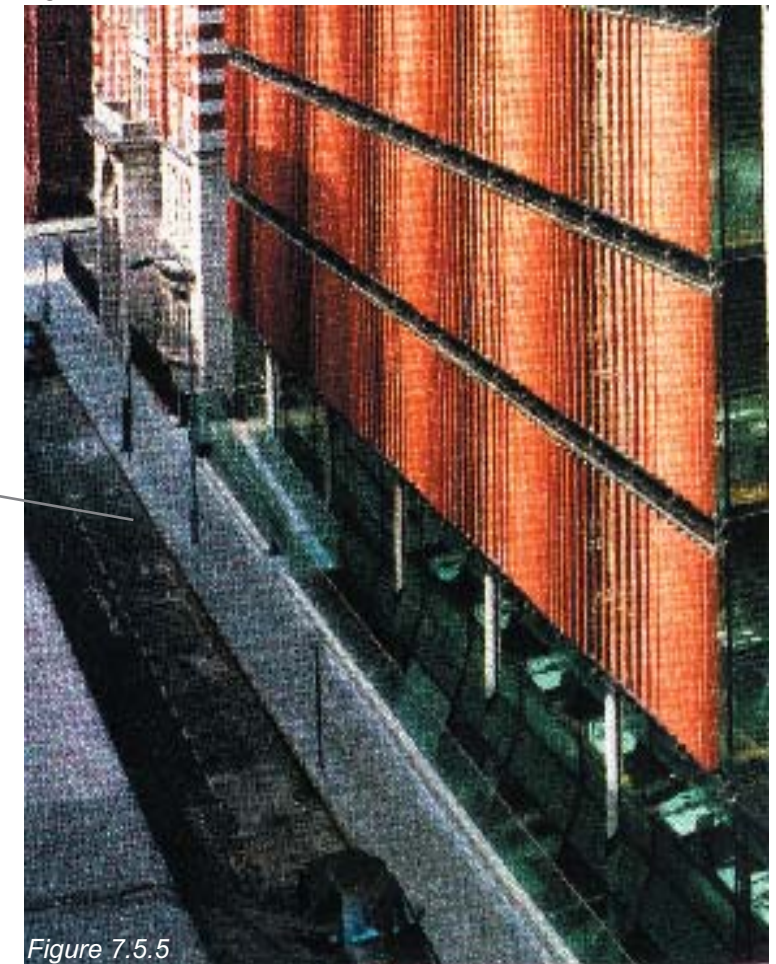
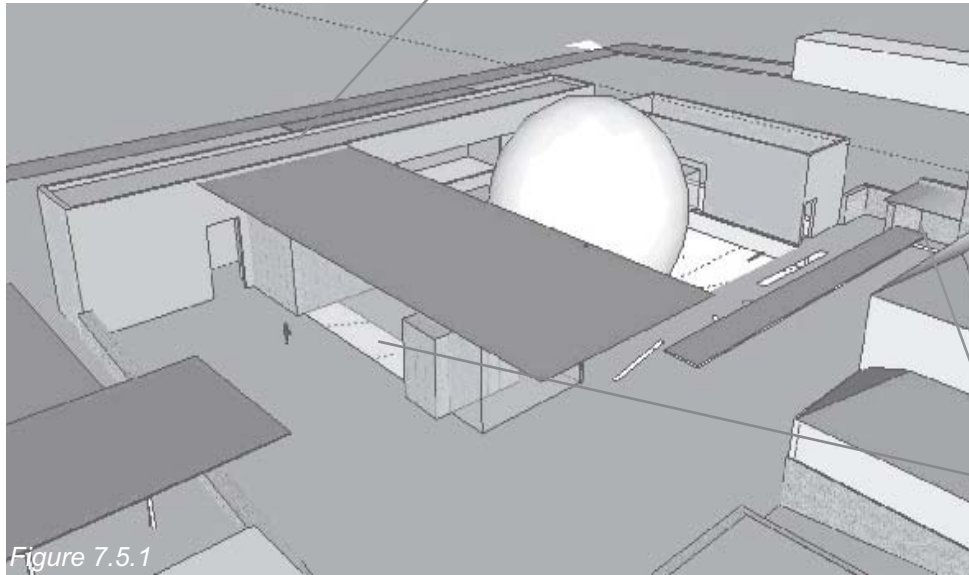

Figure 7.5.2 Orientation

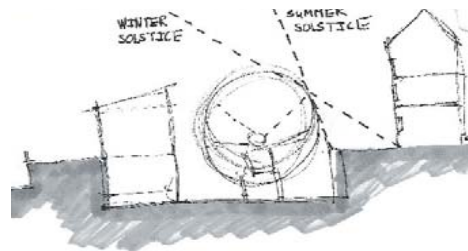
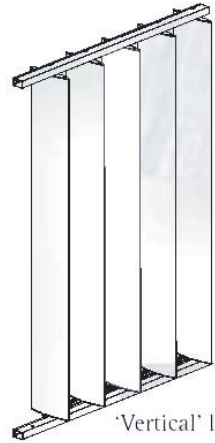
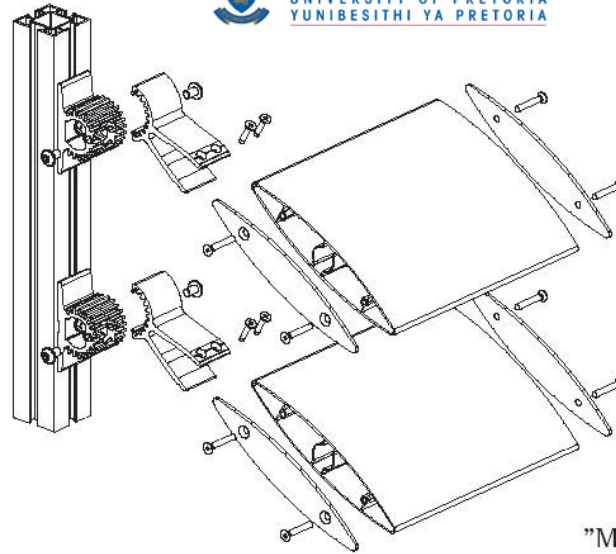

Figure 7.5.3 The astronomy centre does not block natural sunlight to the museum.

Louvre blade fitting



'Vertical' louvre blade fitting



"Multifit" system

Figures 7.5.7 - 7.5.12: Vertical louvre details

The Star Stops

The star stops are allocated areas on the floor in the temporary exhibition space from where the visitor can view certain star constellations on specific dates. These allocated spots had to be calculated with regard to the roof height and angle of view in relation to the constellation coordinates in the sky.

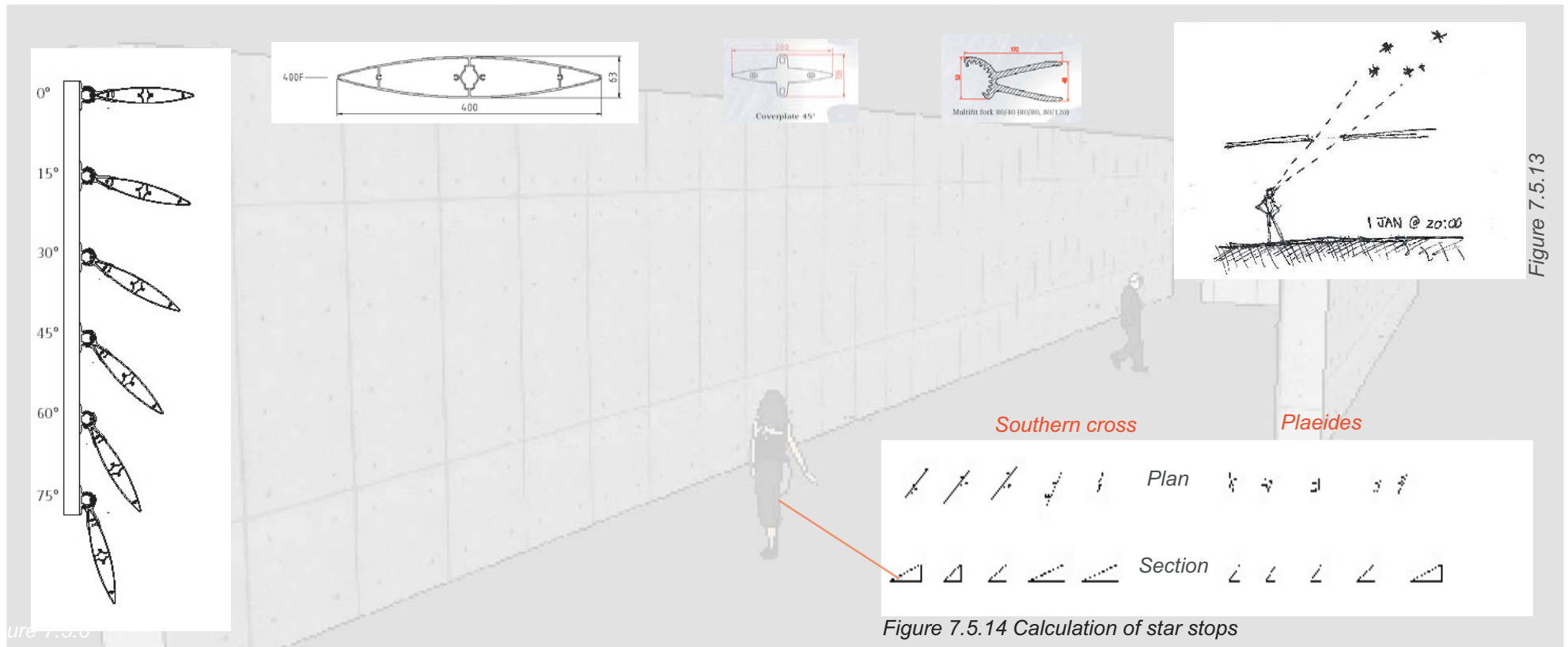

Figure 7.5.13

Figure 7.5.14 Calculation of star stops

7.6 Access

The entire facility is accessible to the user by wheelchair. All the spaces on different levels are connected by ramps with the exception of the *planet room* that is equipped with a stair lift for wheelchairs. None of the ramps exceed the ratio of 1m: 12m.

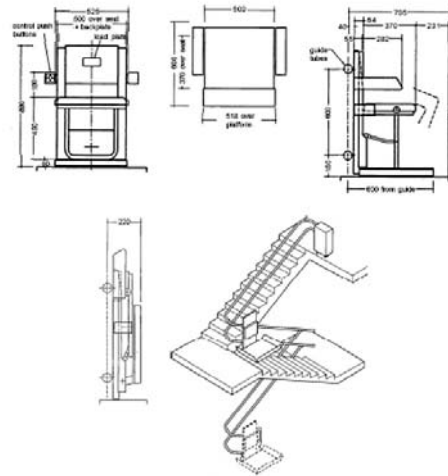

Figure 7.6.1: Detail of stair lift for wheelchairs

7.7 Services

All kitchen and exhibition deliveries are accommodated on the eastern edge of the building, thus clearly distinguishing public and private activities. Services and staff enter the premises by making use of the service road of the zoo east of the astronomy centre.

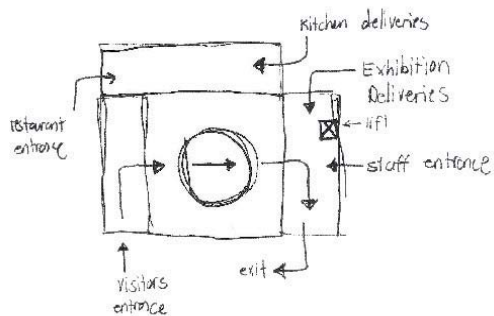

Figure 7.7.1: Facility working diagram

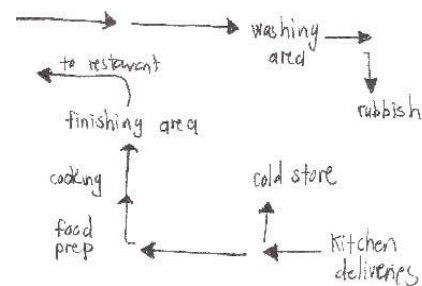

Figure 7.7.2: Working diagram of kitchen



Figure 7.7.3

7.8 The planetarium

Sound and display

Curved surfaces as that of the ceiling in the interior of the planetarium can cause a focal point to develop for sound concentration.

Absorbing surfaces avoid sound concentrations and allow the reverberation time to be matched to the required value (Neufert et al 2002:124).

The sound system will be installed into the bulkhead in the planetarium by a specialist.

Sound insulation ceiling boards will be attached to a lightweight bi-curving display screen of custom perforated aluminium. The display screen will be finished with white enamel paint to reflect the lights that will be projected onto it.

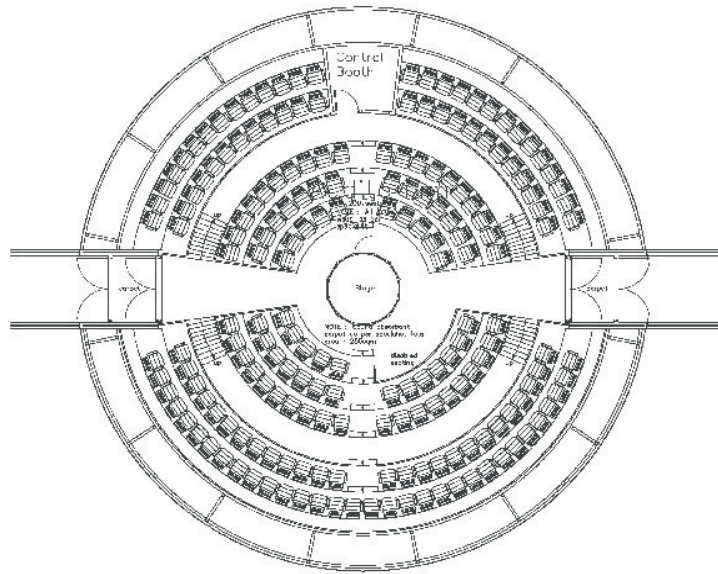

Figure 7.8.1: Seating arrangement in auditorium

Seating arrangement and size determination

Concentric seating

There are various arrangements for seating in planetariums. Concentric seating is the classical arrangement of seating in a planetarium. This arrangement maximises the number of seats in a given dome diameter. In arranging the rows of seats rising from the centre toward the edge of the dome improves viewing conditions for all seats and is most favourable for astronomical presentations (www.zeis.de 04/0707).

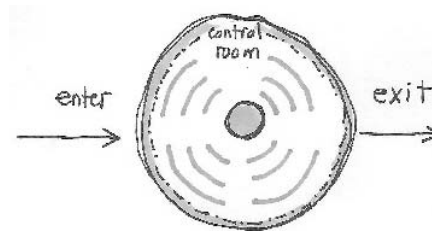

Figure 7.8.2: Working diagram for auditorium

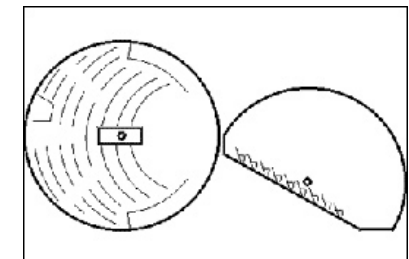
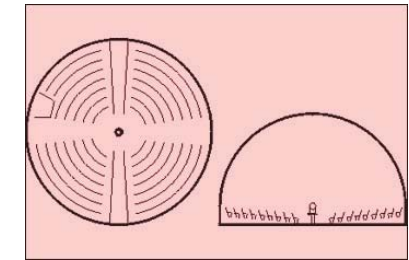
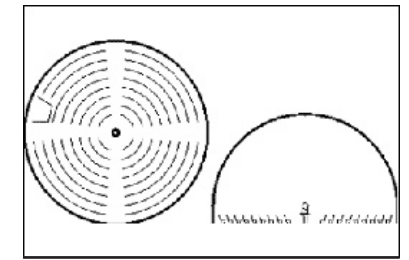
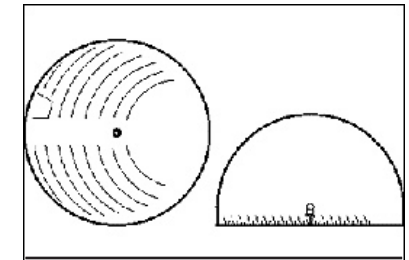
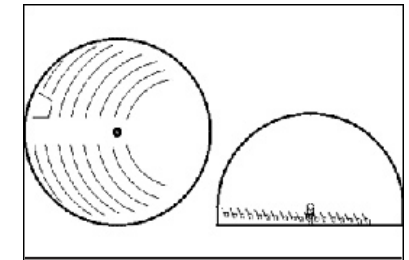

Figure 7.8.3: Variations of seating arrangements in planetariums

Distinction based on size

	Diameter between	Seating Capacities
Small Planetariums	5 m and 12 m	approx. 30 – 100
Medium-size Planetariums	12 m and 18 m	approx. 100 – 200
Large Planetariums	greater than 18 m	approx. 200 – 400

Technical equipment

Content of shows will primarily be astronomical but will also consist of other visual material. A combination of a star projector, a battery of slide projectors and a state of the art immersive video will be used. Show material will be developed, bought or hired through collaboration and exchange with other science centres and planetariums internationally.

Control system

The three projection systems, the sound system as well as the cove and theatre lighting system will be integrated and computer controlled. A flexible degree of automation will be possible ranging from a manually controlled star show with a live presenter in attendance to a fully automated, pre-packaged computer controlled presentation.

Slide projectors

A full dome projection system consisting of two banks of six slide projectors, lensed and linked to illuminate the entire interior surface of the dome will be used. Dramatic low cost visual can be created in such a way.

Immersive video projectors

A 360 ° video projector will be used to create panorama views that provide exceptional visual impact. Computer controlled edge blend technology is used to seamlessly combine the images from the projectors in real time.

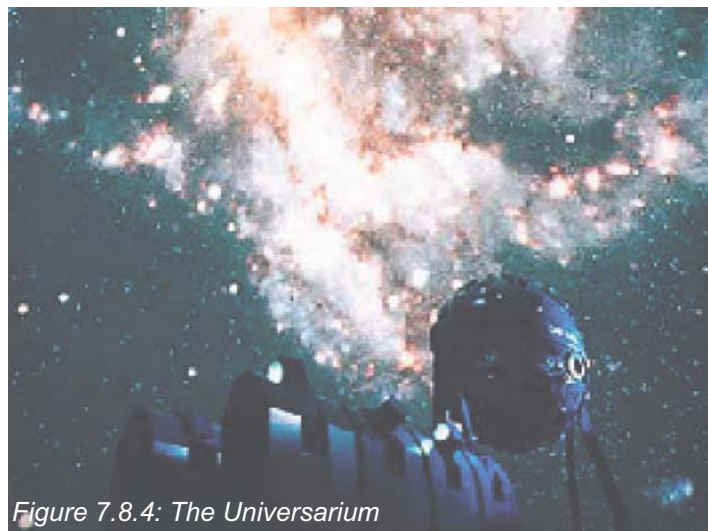

Figure 7.8.4: The Universarium

Star field projector

A fully automated Universarium starfield projector capable of controlling latitude, daily (sidereal) motion, precession, heading (azimuth) and annual motion will be installed. The projector will create a realistic view of the night sky with crisp, accurate, pinpoint stellar images in varying magnitudes, as well as star clusters, nebulae, galaxies and the milky way. The projector will be mounted on an elevator system to lower the instrument into a storage well, to enhance the versatility of the theatre.

Dome diameter	
UNIVERSARIUM M IX / M IX TD	18 m to 30 m (59 ft to 98 ft)
Dome inclination	
UNIVERSARIUM M IX	0°
UNIVERSARIUM M IX TD	up to 30°
Number of seats	
UNIVERSARIUM M IX	approx. 200 to 500
UNIVERSARIUM M IX TD	approx. 180 to 450
Starball	
Horizon height, horizontal dome	
preferable	2200 mm
available	3000 mm
Horizon height, tilted dome	
preferable	1800 mm
Or	project-dependent
Installation area (project-dependent)	
East-West	approx. 2500 mm
North-South	approx. 2400 mm
Weight	approx. 1500 kg
Projectors for Sun, Moon and Planets	
Number	8
Installation area	
East-West	1950 mm
North-South	2320 mm
Inclination range	0° to 30°
Weight	approx. 830 kg
Control cabinet	
Desk	on request
Control panel	450 mm (B) x 250 mm (T) x 50 mm (H)
Control computer	industrial model
Operating program	MS Windows NT
Auditorium	
Temperature	+15°C to 30°C
Temperature constancy	±1°/h
Relative humidity	< 70%
Electrical Connection	
Operating voltage	3x 230/400 VAC ±10%
Fuses and ratings	3x 35 A
Mains supply frequency	50/60 Hz
Power consumption	approx. 16 kVA
Permissible supply failure time	< 10 ms

(www.zeiss.de 04/07/07)



Drawings

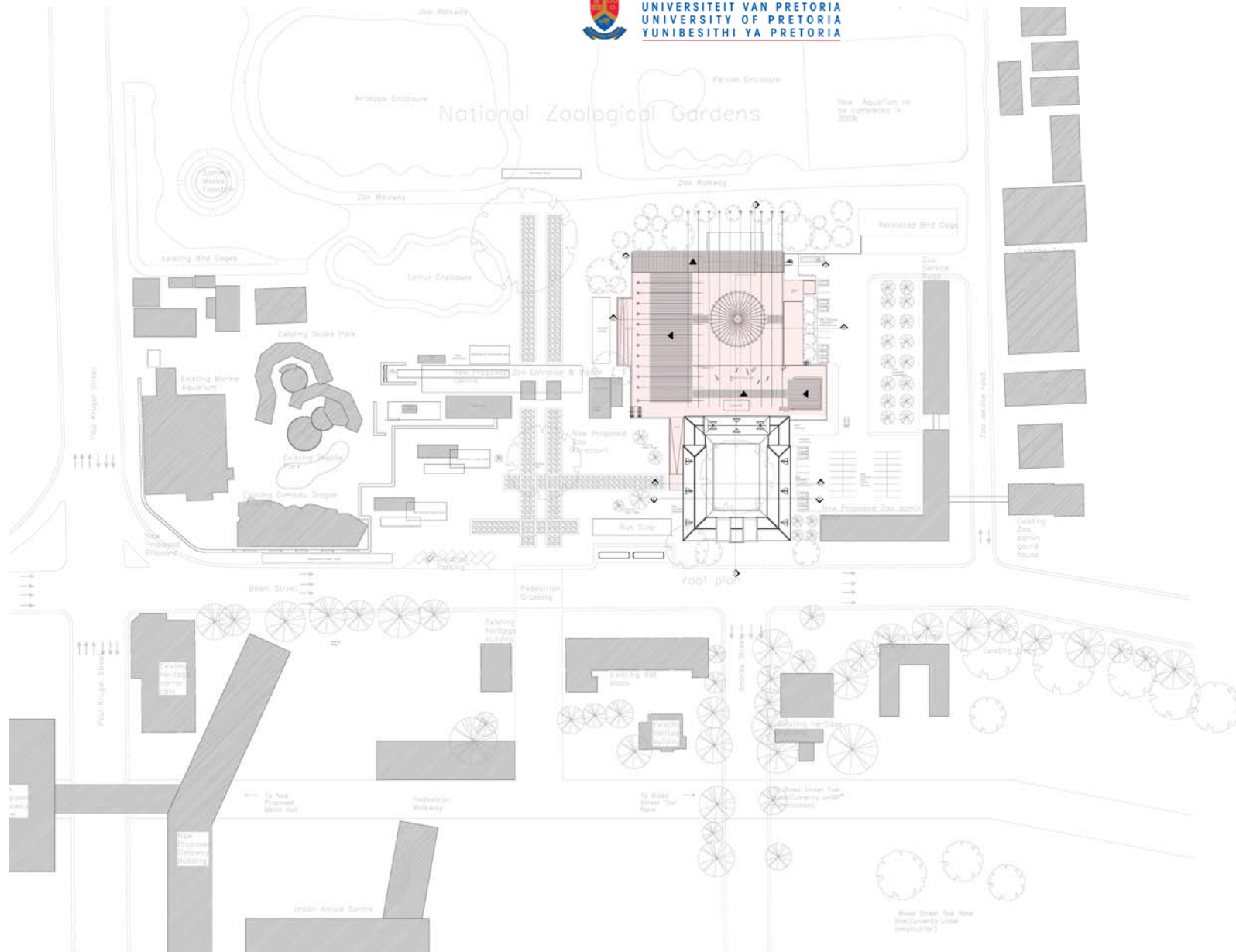

*Astronomical Centre at the National Zoological Gardens
Boom Street, Inner City of Tshwane*

Site Plan

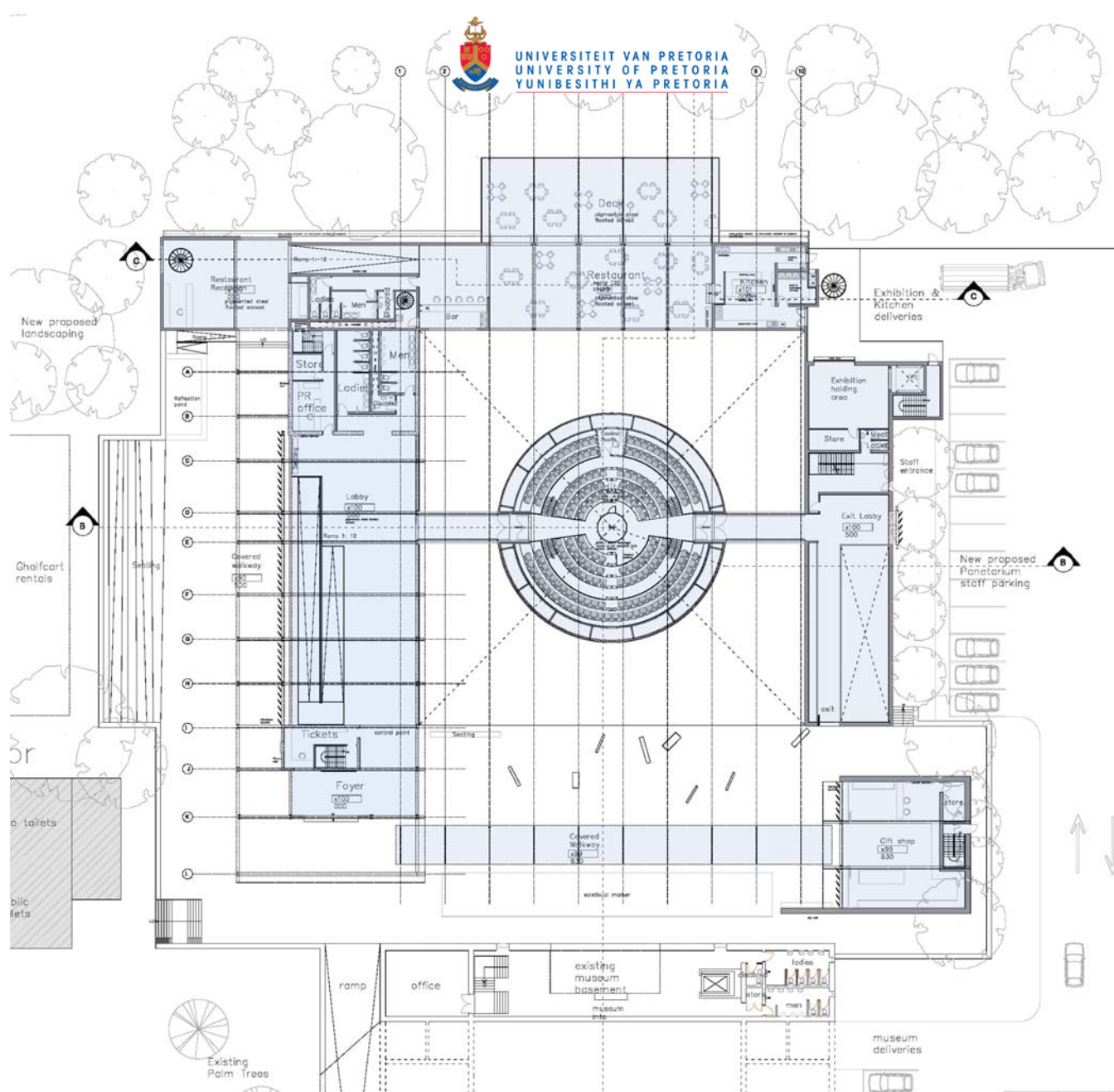

*Astronomical Centre at the National Zoological Gardens
Boom Street, Inner City of Tshwane*

Plan Ground Floor

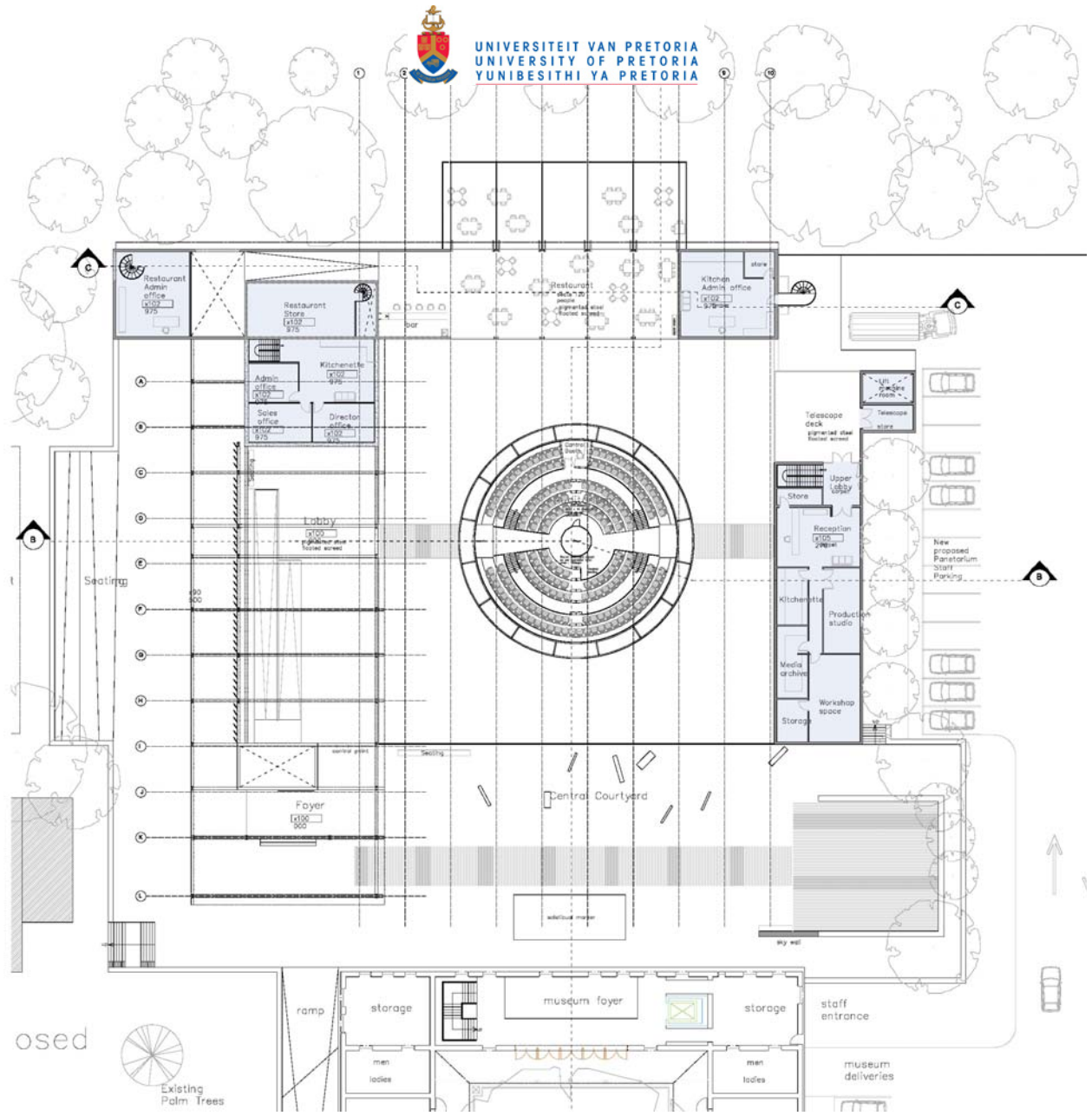

*Astronomical Centre at the National Zoological Gardens
 Boom Street, Inner City of Tshwane*

Plan First Floor

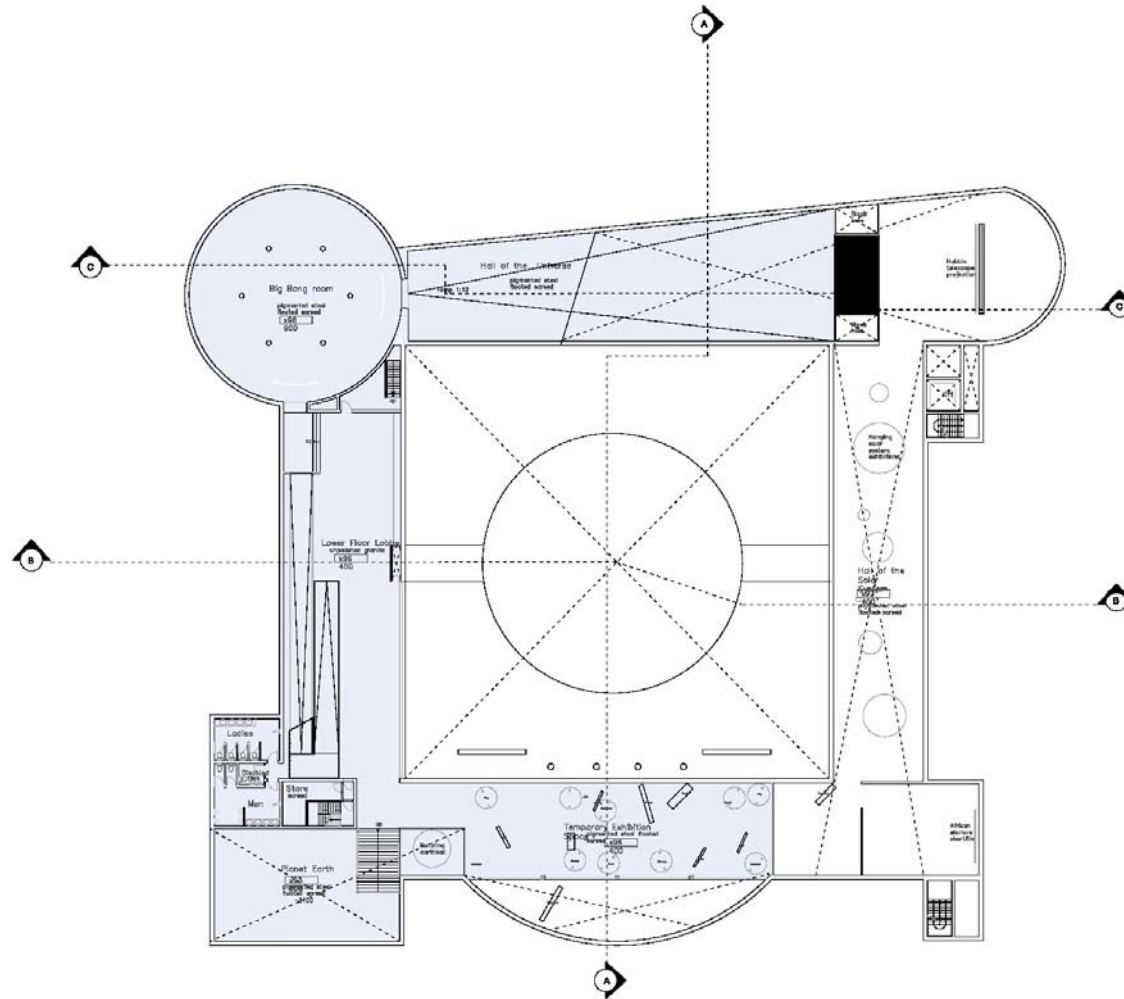

*Astronomical Centre at the National Zoological Gardens
Boom Street, Inner City of Tshwane*

Plan Basement 1

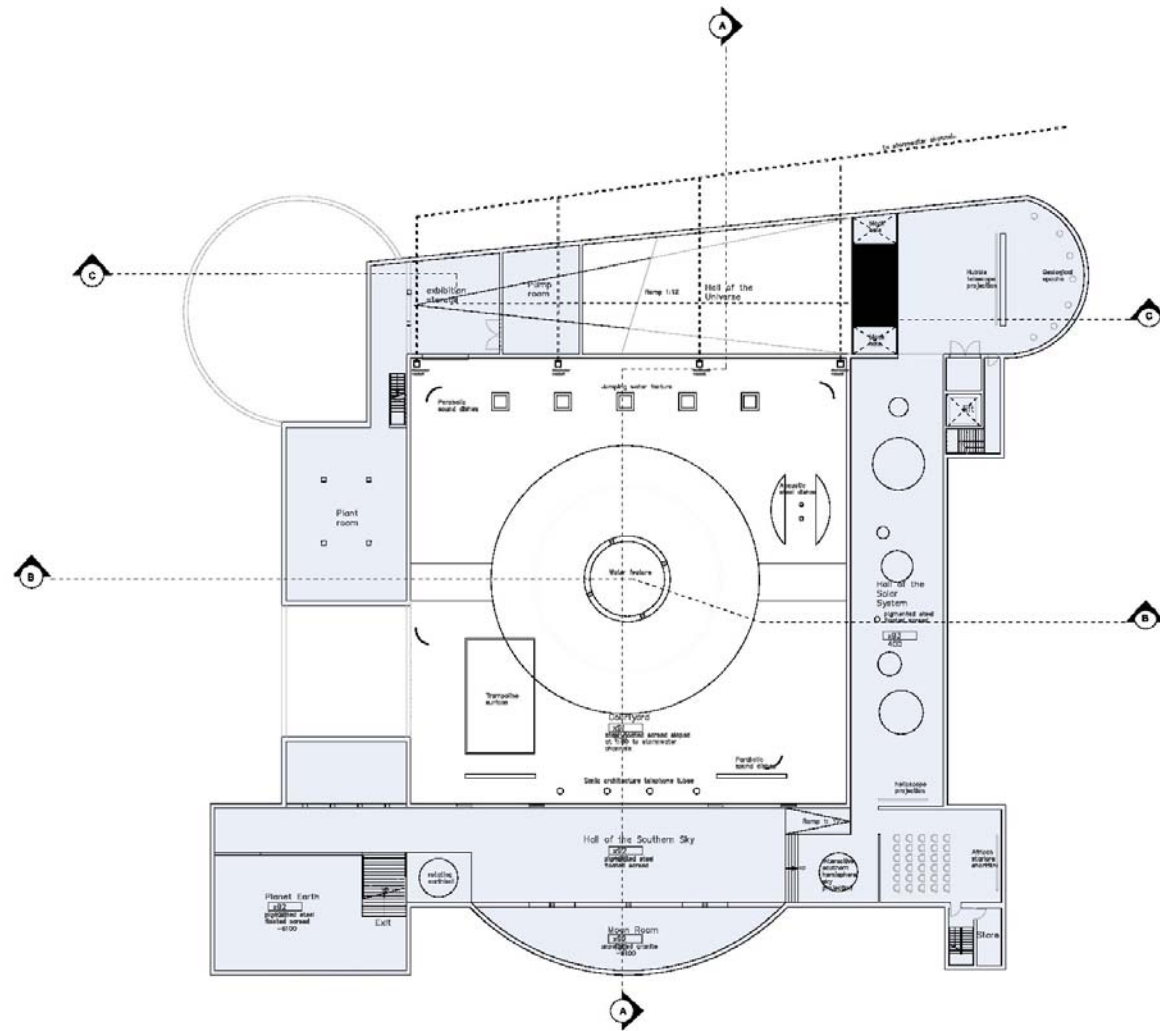

*Astronomical Centre at the National Zoological Gardens
 Boom Street, Inner City of Tshwane*

Plan Basement 2

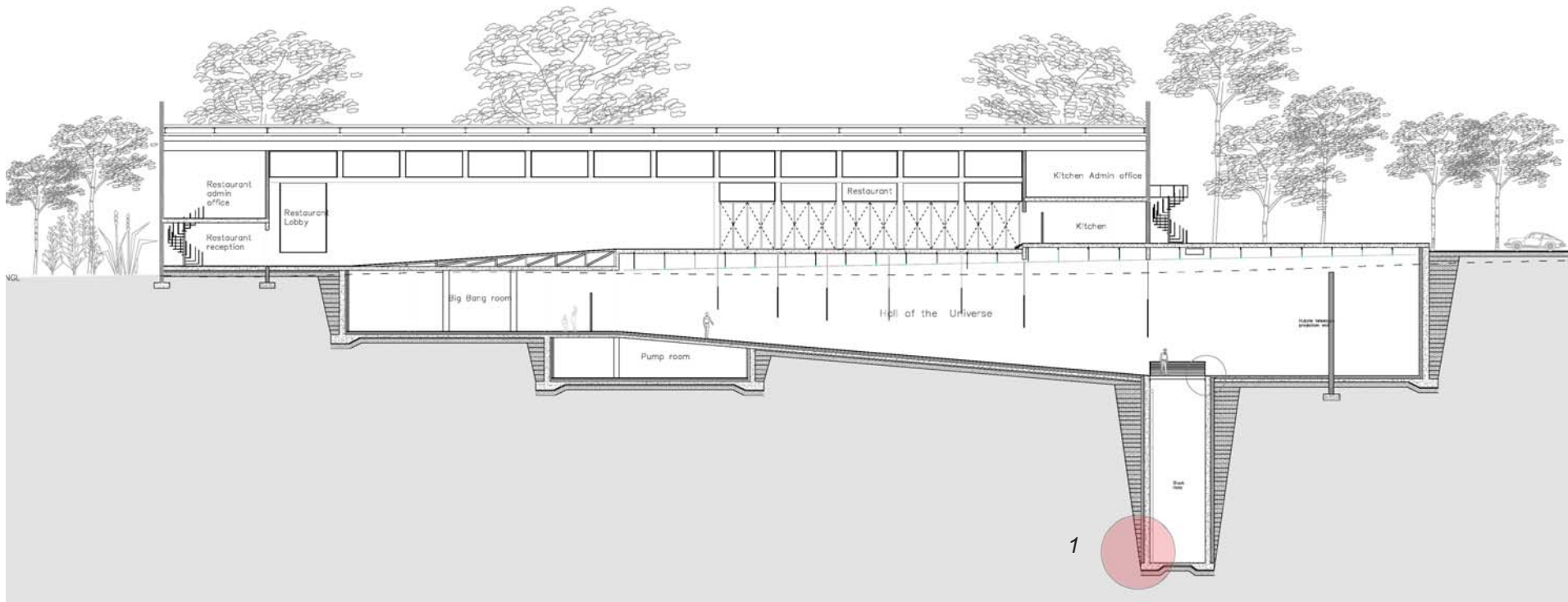

*Astronomical Centre at the National Zoological Gardens
Boom Street, Inner City of Tshwane*

Section B-B

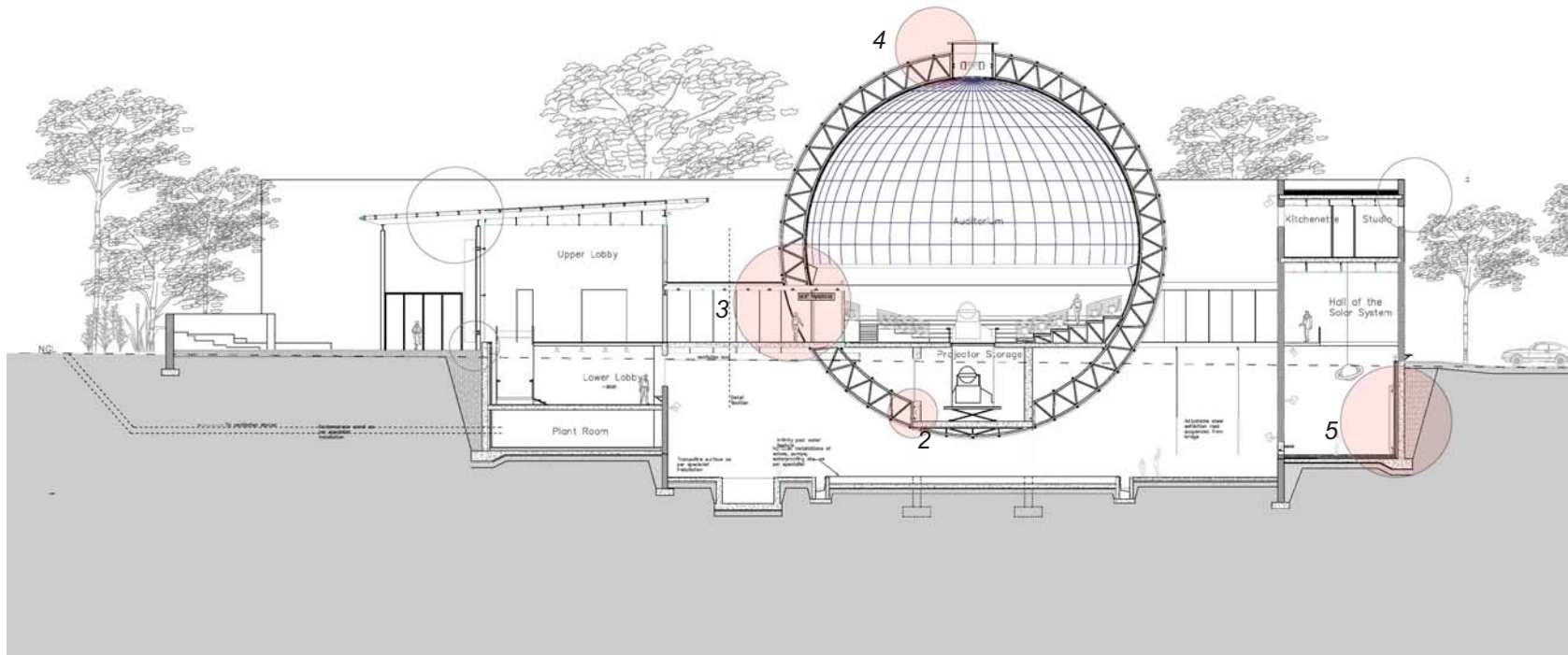

*Astronomical Centre at the National Zoological Gardens
Boom Street, Inner City of Tshwane*

Section C-C

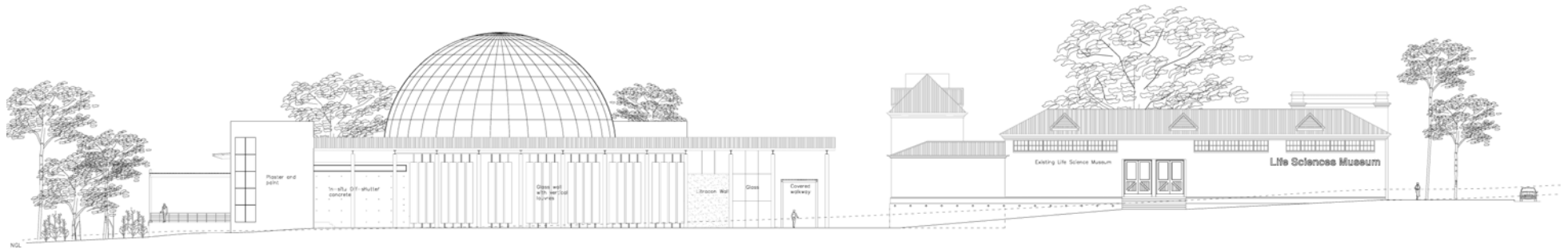
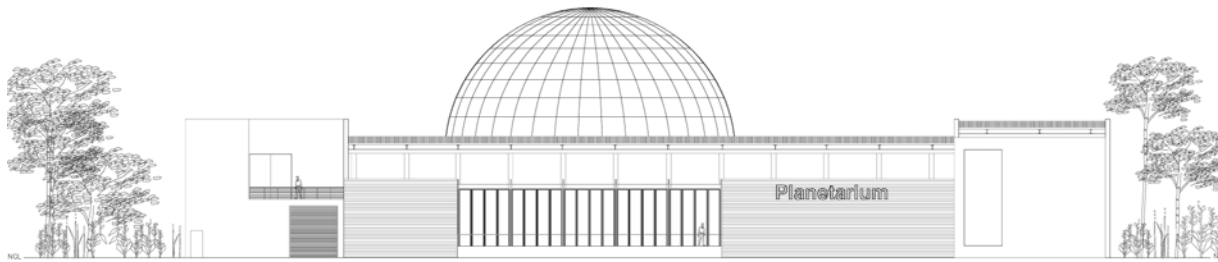

*Astronomical Centre at the National Zoological Gardens
Boom Street, Inner City of Tshwane*

Elevation North, Elevation West

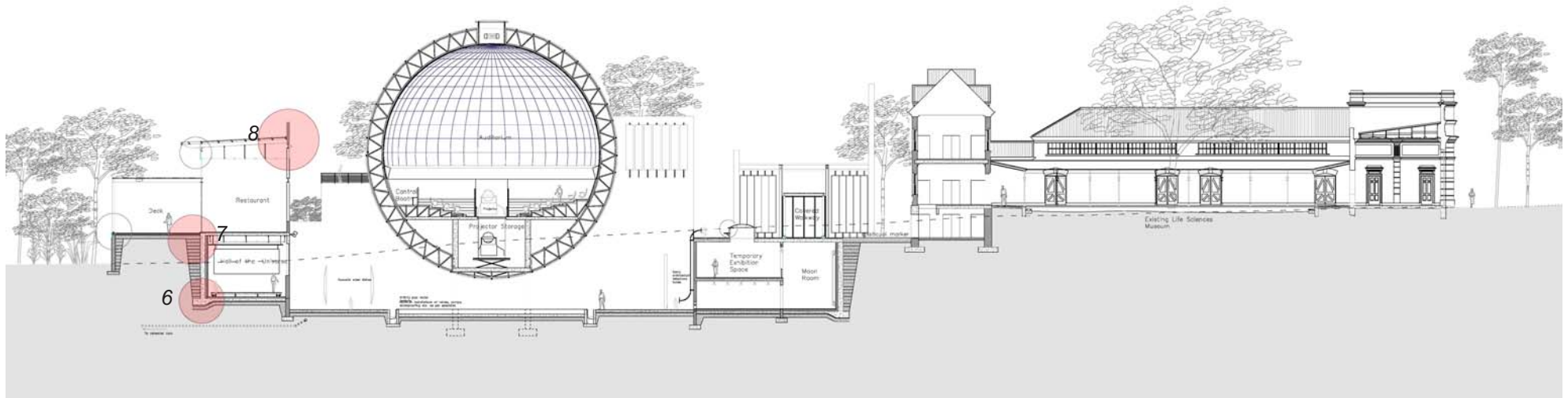

*Astronomical Centre at the National Zoological Gardens
Boom Street, Inner City of Tshwane*

Section A-A

Detail 4

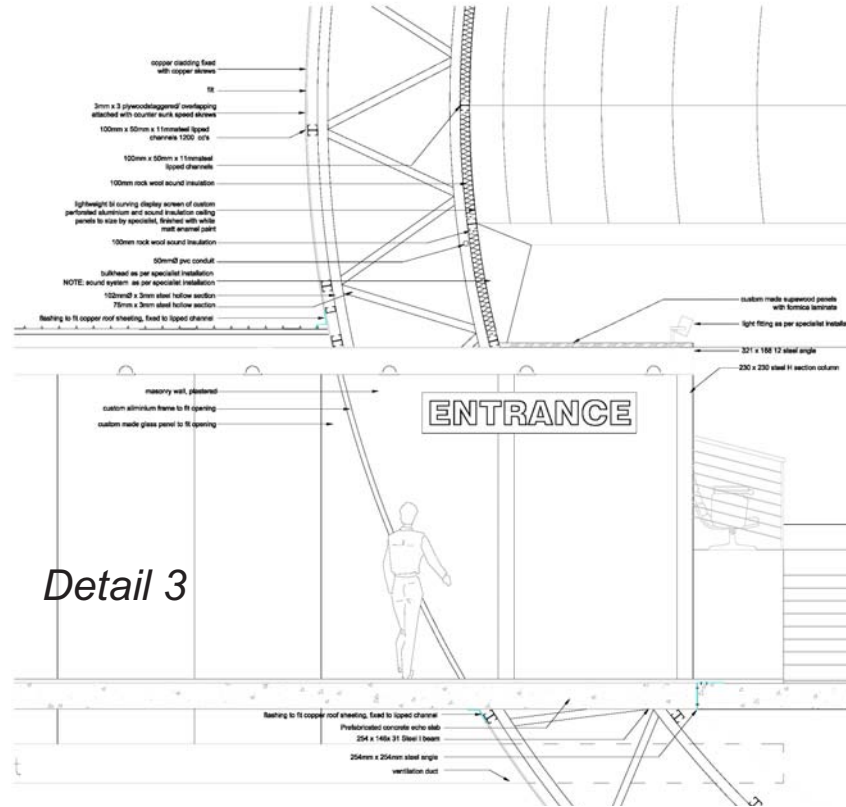
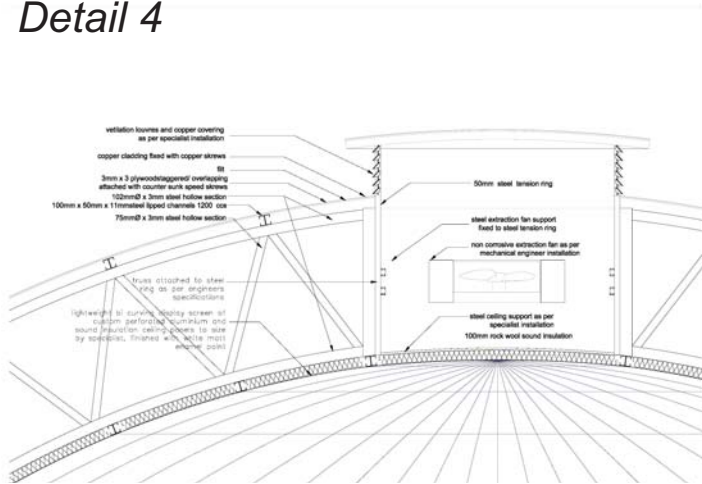

Detail 3

Detail 8

Astronomical Centre at the National Zoological Gardens
Boom Street, Inner City of Tshwane

Details

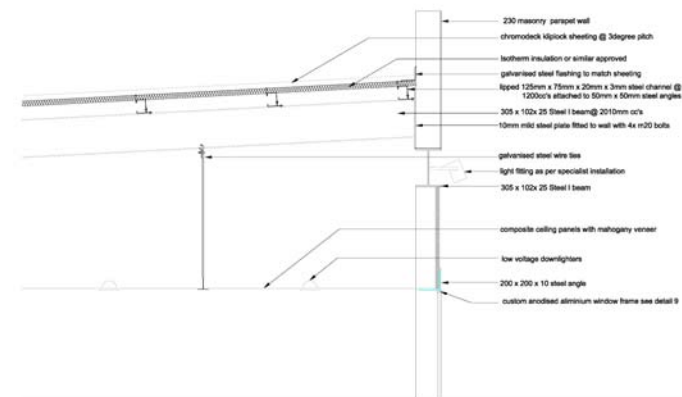

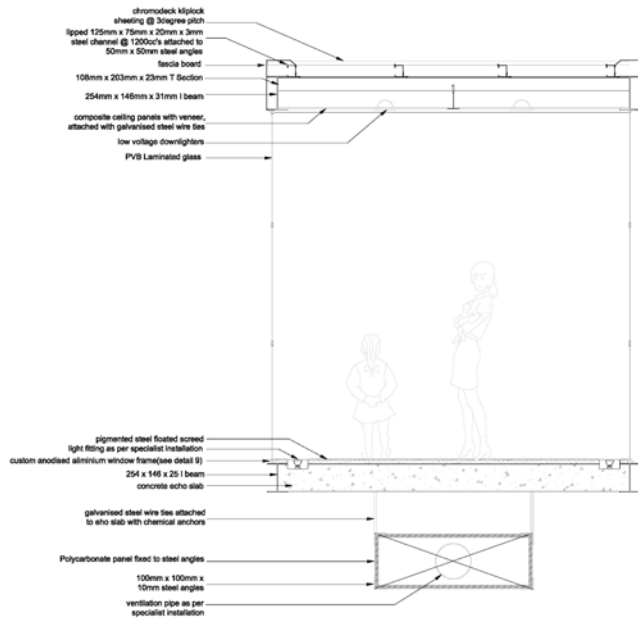

Detail 9

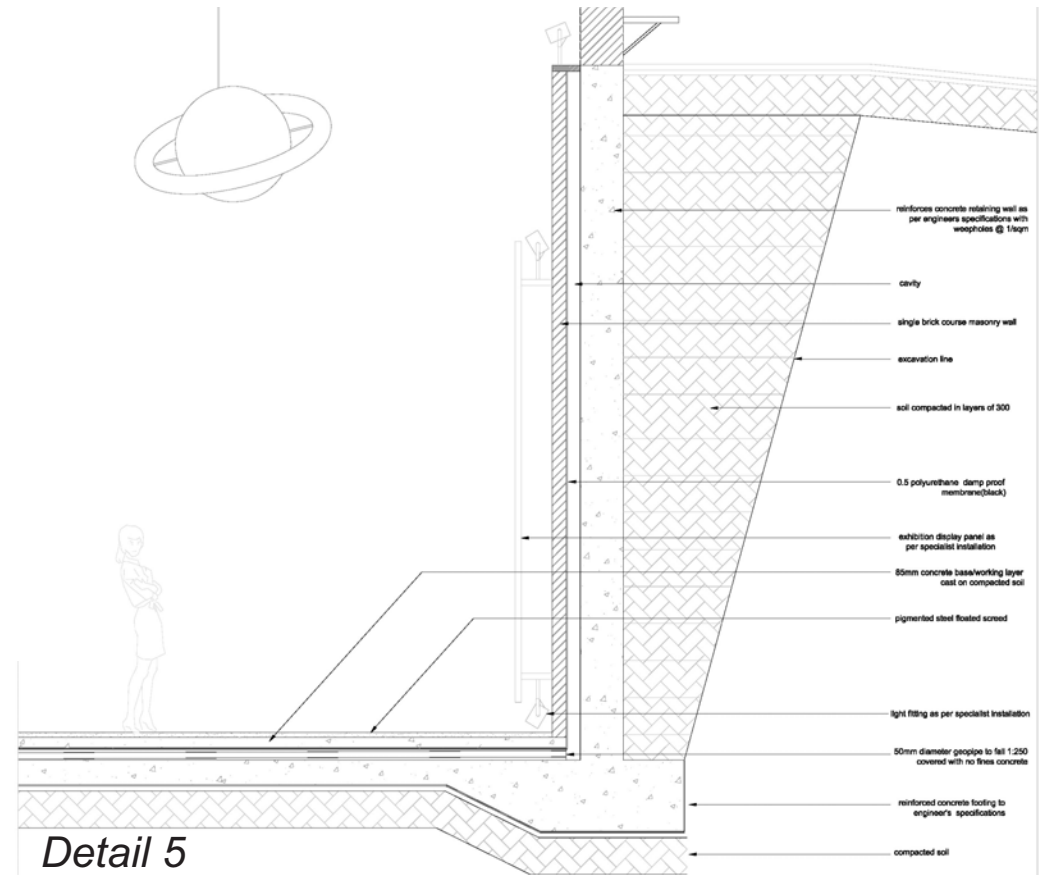

Detail 5

Astronomical Centre at the National Zoological Gardens
 Boom Street, Inner City of Tshwane

Details

Detail 6

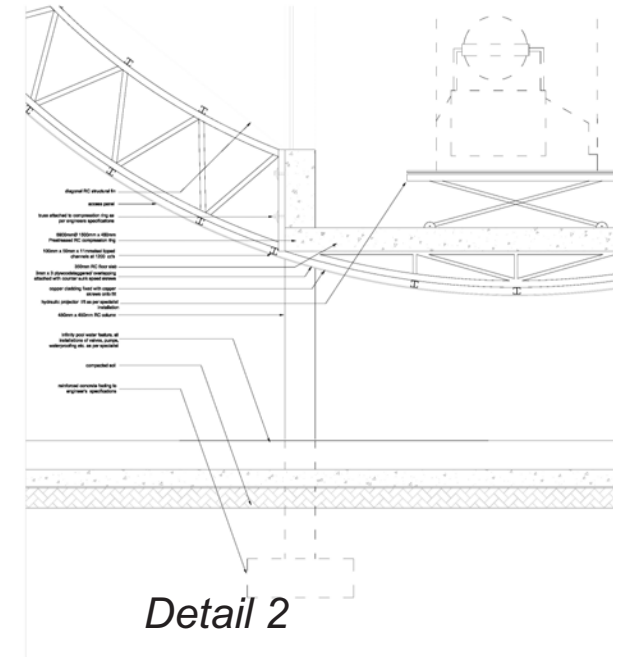
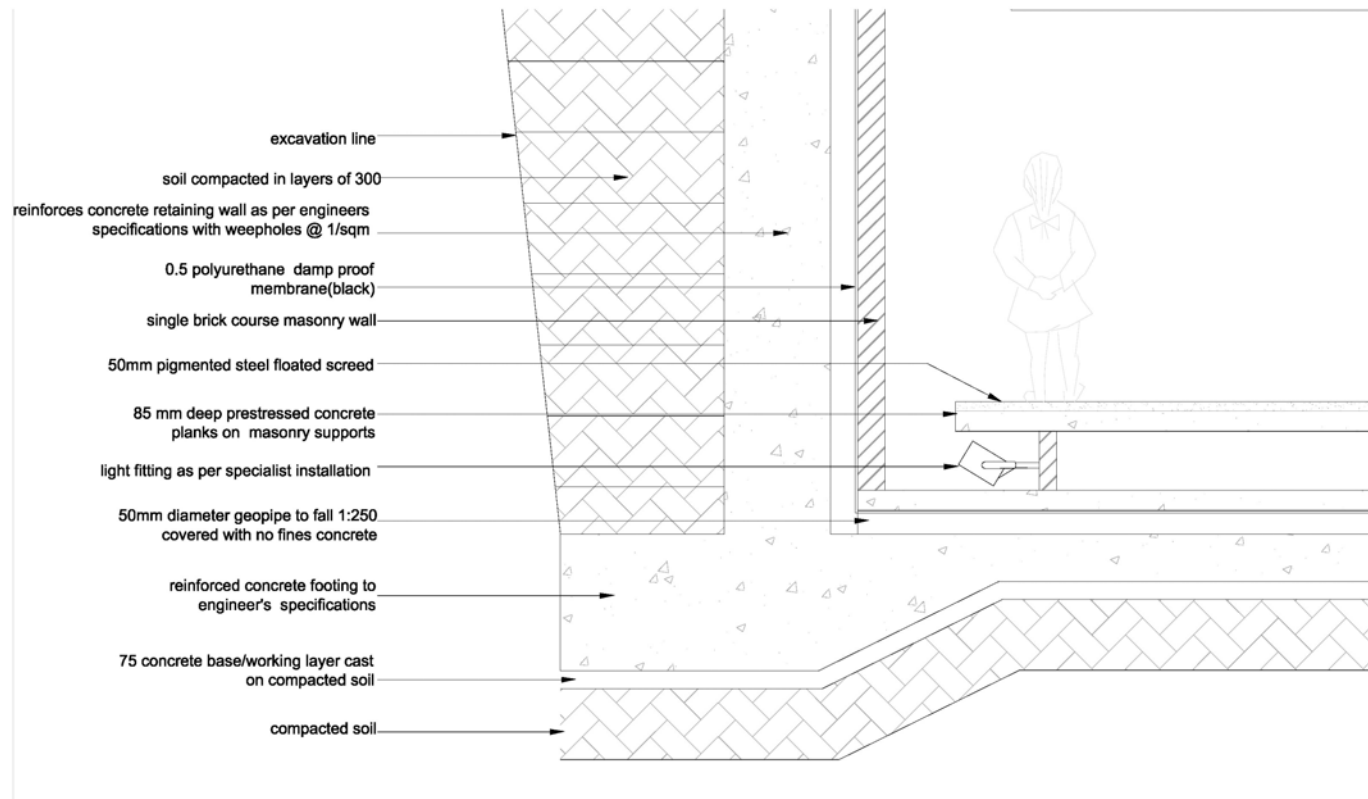

*Astronomical Centre at the National Zoological Gardens
 Boom Street, Inner City of Tshwane*

Details

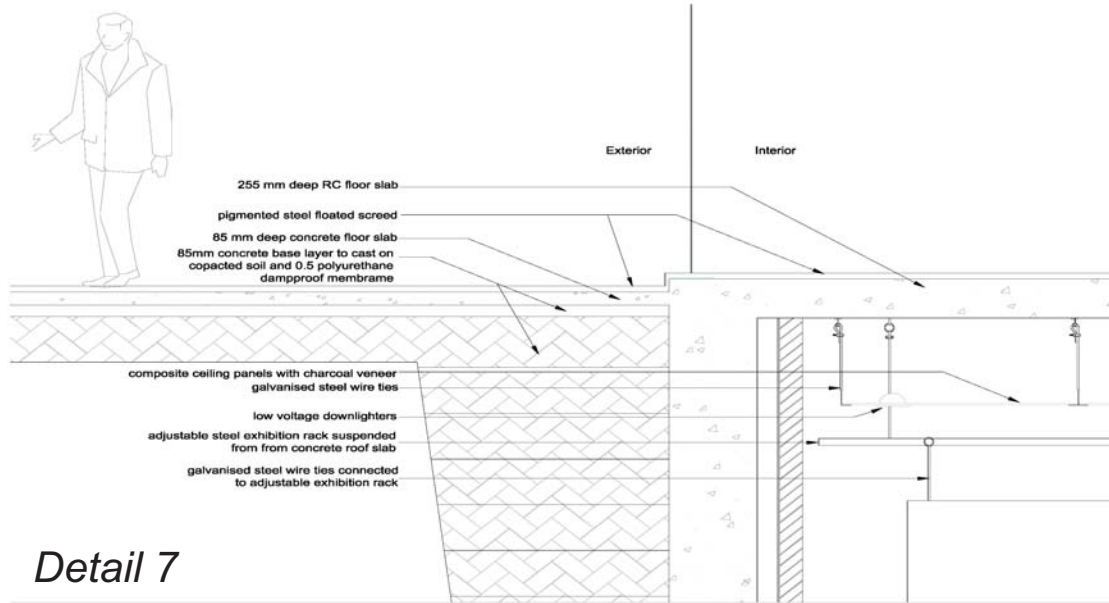

*Astronomical Centre at the National Zoological Gardens
 Boom Street, Inner City of Tshwane*

Details

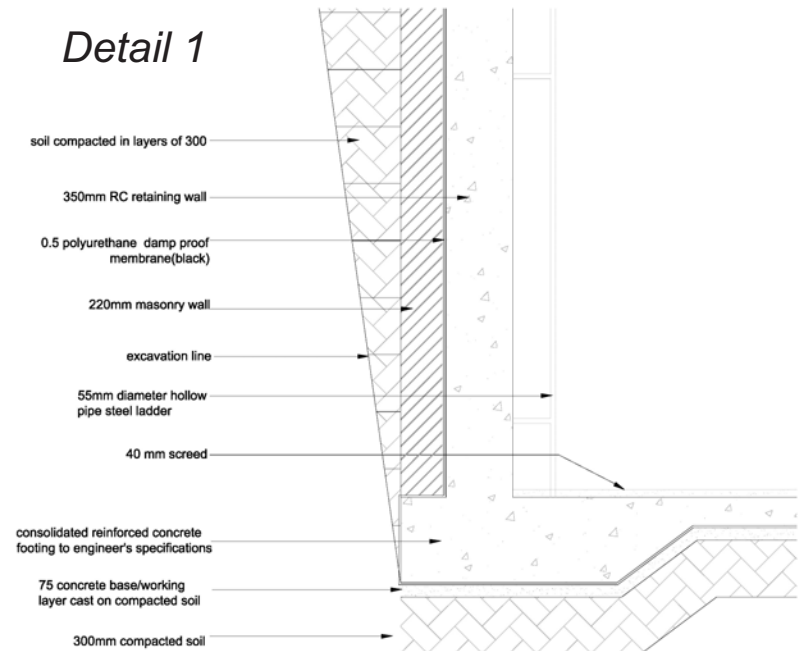



Addendum 1 Baseline Criteria

Introduction

Non-renewable resources are being depleted and there is increasing environmental damage as a result of human activities. Therefore, sustainability becomes a vital issue in the way we live and work. Buildings can play an important role in supporting sustainability. This can be achieved by careful considerations in planning, design decisions, material specifications etc. are carefully evaluated in terms of their long term impact on the economic, social and environmental sustainability of a society and the natural environment (Gibbert, 2003 : 1). The baseline study is a target setting design guideline that has been considered prior to the conceptualizing of the project. In this chapter these targets will be discussed and the performance of each of these targets measured by making use of the Sustainable Building Assessment Tool (SBAT).



Figure 9.1

Social Issues

1) Occupant comfort

Target Set

All the interior spaces should well lit with natural light, ventilated, noise should be minimised, all spaces should have exterior views within six meters and there should be enough access to green outside space(Gibbert 2003 : 4).

Design Performance

The levels above the ground are very transparent and receive an abundance of natural light, controlled with louvers. As a result of the nature of the dark exhibition space emulating the cosmos, the lower sections receive less natural light, there are however access to outside space from this area.

The site is off the street and away from noise. The majority of staff workspace has external views.

rating: 4.5

2) Inclusive environments

Target Set

The building should be located less than 100m from disabled accessible public transport. All spaces in the building should be accessible by wheelchair, thus make use of appropriate ramps other technologies. Comprehensive information should be provided; toilets should be easily accessible within every 50m. Furniture and fittings should be easily accessible (Gibbert 2003 : 4).

Design Performance

The site is within 100m from the new proposed tram stop and

bus stop being proposed by the framework. The entire building is accessible by wheelchair. All toilets, furniture and fittings are easily accessible.

rating: 4.6

3) Access to facilities

Target Set

Childcare should be provided or be within 3km. Banking, retail and communication facilities should be nearby (within 3km). Homes for staff or alternatively public transport facilities should be within nearby(Gibbert 2003 : 5).

Design Performance

As the facility is located on the northern edge of the CBD banking, retail and communication facilities are within walking distance. Public transport facilities are also within walking distance

rating: 4

4) Participation and control

Target Set

Furniture and fittings should be adjustable by the user; this includes lighting and environmental fittings. There should be social spaces and easy access to refreshments. Spaces should be able to be shared (Gibbert 2003 : 5).

Design Performance

The furniture and fittings are adjustable throughout the staff spaces and where applicable in the visitor spaces. Within the admin section and the production section there are social spaces and kitchenettes. As the facility has a very specific function, most of the spaces cannot be shared. The auditorium however has a projection store that allows this space to be used alternatively.

rating: 3.6

5) Education, health and safety

Target Set

Access to support for learning should be provided. Measures should be taken to ensure that areas of the buildings and routes to and from the building are safe. The materials should have no negative effect on the indoor air quality (Gibbert 2003 : 6).

Design Performance

As the facility is off the street and part of the new upgraded zoo forecourt development, all the edges of the building and routes to and from the building are more transparent and will be visually supervised, creating a safe child friendly environment. None of the materials are hazardous and the conventions applied in the design complies with all the health and safety regulations applicable.

rating: 4.6

1) Local Economy

Target Set

The construction should be carried out by local contractors, 80% the construction should be

carried out locally and the materials, furniture and fitting should be sourced locally. Opportunities should be created for small businesses and maintenance should be carried out by local contractors (Gibbert 2003: 8).

Design Performance

The construction of the entire facility is designed to be easily constructed locally, instead of using the more popular geodesic dome system, the sphere has been designed to consist of a series of circular trusses that can be manufactured locally. The only fitting that will have to be sourced internationally is the star projector. All the materials used and all maintenance contractors can be sourced locally.

rating: 4.6

2) Efficiency of Use

Target Set

Minimise non-usable space. Building should be occupied toward all potential hours the building could be used. Building must be accessible to telephones and internet. Building design should be

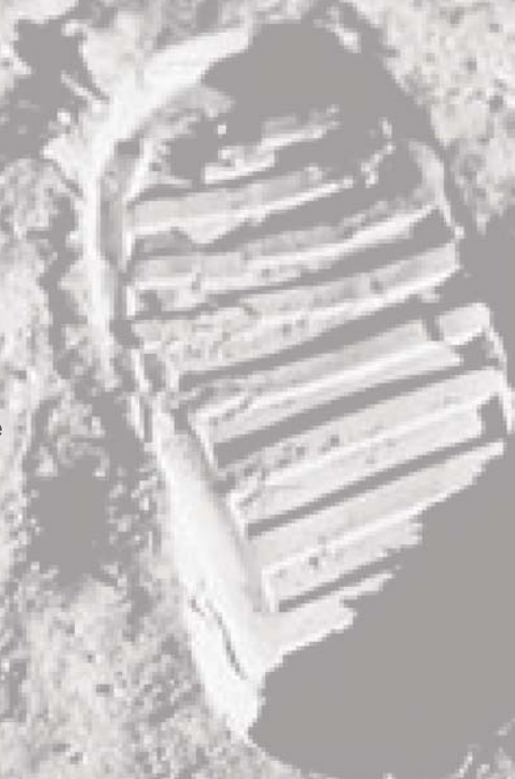

Figure 9.2

coordinated with material and component sizes in order to minimise wastage (Gibbert 2003 : 8).

Design Performance

The building and its nature as a public facility, therefore the public exhibition are designed larger that is specified by building regulations. All of the other areas, however minimises non usable space. The building, operating by day and night, will be used towards its full potential. With the exception of the sphere, the building's components and materials are coordinated to minimise wastage.

rating: 3.6

3) Adaptability and Flexibility

Target Set

The vertical dimensions of rooms should be a minimum of 3m. External space should be

accessible electrical and communication equipment should be installed for servicing (Gibbert 2003 : 9).

Design Performance

The vertical dimensions of 90% of the rooms exceed 3m. As the facility has a very specific function, the majority of spaces cannot be easily adapted. The auditorium however, has a projection store that allows this space to be used alternatively.

rating: 1.6

4) Ongoing costs

Target Set

Building must be able to be cleaned and maintained easily. New staff members must receive training on the building system. Water and energy must have easy metering systems. Materials used in the building on a daily and maintenance contractors basis must be sourced locally (Gibbert 2003 : 9).

Design Performance

The design allows for easy and accessible maintenance and cleaning. All materials used in the building on a daily and maintenance contractors can be sourced locally, such as that of telescopes and digital equipment. Projection material can be sourced through digital technologies.

rating: 3.9

5) Capital costs

Target Set

Ensure involvement from small local contractors. Make use of existing buildings. Allocate costs to sustainable technology and cost not more that 15% above national average cost for the building type (Gibbert 2003 : 10).

Design Performance

As the building is centrally located local contractors can be



used. The structure of the sphere is also deliberately designed to be easily constructed and assembled. The average building cost is not exceeded by more than 15%.

rating: 4.6

Environmental Issues

1) Water

Target Set

Rainwater should be harvested, stored and used. Use water efficient devices. Runoff should be reduced by absorbent surfaces and plants with low water requirement should be used (Gibbert 2003 : 11).

Design Performance

Rainwater is harvested from the sunken courtyard. Absorbent surfaces are used on the upper courtyards and no grass or other landscaping that requires a lot of water is used.

rating: 3.6

2) Energy

Target Set

The building should be at least 400m from public transport. Passive ventilation and environmental control system should be used. Energy efficient devices and fittings should be used. Renewable energy should be used (Gibbert 2003 : 11).

Design Performance

The building is within 100m of public transport. Appliances / lighting fixtures that are classed as highly energy efficient are used.

rating: 2.6

3) Recycling/Re-use

Target Set

Toxic, inorganic and organic waste should be recycled. Sewerage and construction waste should be recycled on site (Gibbert 2003 : 12).

All waste will be recycled either on the property of the Zoo or elsewhere.

rating: 2.3

4) Site

Target Set

The building must not have a harmful effect on neighbouring buildings. Site should have extension vegetation. Vegetation must provide habitat for animals

and must not require heavy artificial input (Gibbert 2003 : 12).

Design Performance

The building has no harmful effect on the Museum. A portion of this site has already been disturbed by zoo excavations. The site will have a fair amount of vegetation that will provide habitat for zoo birds and insects. The landscape has no lawns or other landscaping that requires mechanical maintenance.

rating: 2.1

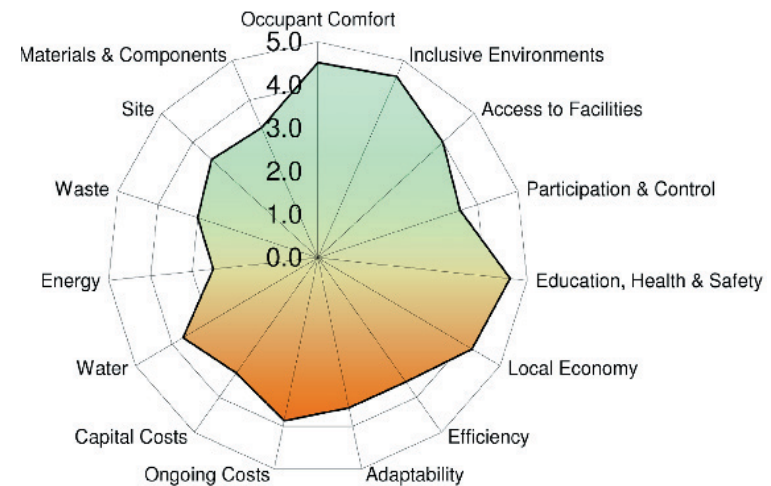

Figure 9.3 Indication of performance of design in terms of sustainability

5) *Materials and Components*

Target Set

Use a minimum amount of materials with high embodied energy. Do not use any material or components that require ozone depleting processes. Maximise amount of materials or components that are recycled sources. Minimise the volume / area of the site to be disturbed. (Gibbert 2003 : 13).

Design Performance

The majority of material used in the design has a low embodied energy, such as concrete and bricks. Materials such as aluminium on the other hand, are minimised and purely used in the public areas for aesthetic reasons.

rating: 2.6

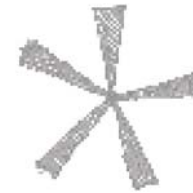

References

Bibliography

Kruger, P, Interview with author, 1 January 2007, South Africa, City of Tshwane, Metropolitan municipality, 2006, Tshwane Inner City Programme : Spatial development Framework, presentation by Gapp Architects and urban designers.

King, Henry C. "Geared to the Stars; the evolution of planetariums, orreries, and astronomical clocks" University of Toronto Press, 1978

Lynch, K, *A theory of good city form*, Massachusetts Institute of Technology, Massachusetts, 1981, p71 – p83.

Jordaan, G, *Pretoria as 'Urbs Quadrata'*, Architecture SA May / June, Picasso Headline Pty(Ltd), 1989, p26 – 29.

Capitol Consortium, 35 & Meyer, 56, Municipality of Pretoria, 2002.

Futogawa, Y, GA Architect 12, Tadao Ando Vol. 2 1988 - 1993, A.D.A. Edita, Tokyo.

Ando T, *Fabrica Benetton Communication Research Center*, Japan Architect, Yearbook 2000, Shinkenchiku-sha Co. Ltd, Japan, 2000, 90 – 95.

Carbonero, *Musee Reina Sofia Extension*, L Architecture d Aujourd Hui, Swets, Amsterdam, Nov – Dec 2001, 337.

Pearson, C, *Polshak Partners brings the stars to the masses in the Rose Center for Earth and Space*, Architectural record, Swets, Amsterdam, 2000, p 99 – 109.

Gibbert, J, *Sustainable Building Assessment Tool Manual* obtained by the Faculty of Engineering and the Built Environment, University of Pretoria,2003.

Quotation by M Ehrman in S Barnett, *Desiderata, a survival guide for life*, Ebury Press, Random House,London, 2002.

This-Evensen, *Architypes in Architecture*, Norwegian University Press, Oslo, 1978.

Capra, F, *The Web of Life: a new synthesis of mind and matter*, Harper Collins, 1982.

Bronowski, J, *The Ascent of Man*, British Broadcasting Corporation, London, 1973.

Quotation by E.L. Boulee, in H. Rosenau, *Boulee & Visionary Architecture*, London 1974, p. 89.

Alberti, L.B, in R Goldwater and M Treves(eds), *Artists on Art*, London, 1979, p. 35.

Ching, D.K, *Architecture, Form, Space and Order*, 2nd Edition, Van Nostrand Reinhold, New York, 1997.

Norberg-Schulz, C, *Genius Loci*, Academy Editions, London, 1980.

Group 3, Urban Analysis of Pretoria CBD prepared by M-Arch(Prof) class of 2007, Sections and Elevations, March 2007.

National Zoological Gardens Visitors Statistics 2003 – 2006, obtained by M Kitzhof, March 2007.

McHale, J, Buckminster Fuller, George Braziller Inc. New York, 1962.

Le Roux, S, *Plekke en geboue van Pretoria – n oorsig van hulle argitekturele en stedelike belang*, Stadsraad van Pretoria, Pretoria, 1991.

Adler, D, *Metric Handbook Architects' Data*, 2002.

E, Neufert, P, Neufert edited by Baiche, B, Walliman, N, *Neufert Architect' Data Third Edition*, Blackwell Publishing, Oxford, 2002.

Websites

<http://www.mashabanerose.co.za>

<http://whc.unesco.org/en/initiatives/32/>

<http://www.nationalgeographic.com/>

<http://www.nationalgeographic.com/>

<http://www.providenceri.com>

<http://photography.nationalgeographic.com/photography/index.html>

http://www.southafrica.info/ess_info/sa_glance/scitech/cosmicafrica.htm

<http://www.worldsfamousphotos.com>

www.manchesteronline.co.uk/ewm/19/lg/48.jpg

<http://ahmadshahied.fotopages.com/>

<http://www.immediart.com>

<http://www.time.com>

<http://www.wikipedia.com>

<http://propu.com>

<http://archspace.com>

<http://www.zeis.de>

<http://www.duco.com>

<http://www.bnsc.gov.uk/>

<http://www.focks.com/>

<http://www.amnh.org/rose/>

http://www.radio-active.net.au/blog/2006/04/Earthrise_Poster_main.gif

Rogers, A, <http://www.cosmicafrica.co.za>, *Cosmic Africa Explores Africa's Astronomy*, Science magazine for Africa, 2003.

Interviews

Dr C Flanagan, Director of the Johannesburg Planetarium

Mrs R Horak, Director of Sci Enza, University of Pretoria

Mr M Kitshof, National Zoological Garden's in house architect

Prof W Burdzig, Department of Structural Engineering, University of Pretoria

Mr C von Geyso, Structural Engineer

Mr R Wade, Nkwe Observatory, Tswane