

**BEYOND FUNCTION: *PRETORIA STATION INTERCHANGE AND CIVIC SPACE***

MBASA XOLISA TSHOMBE MArch[Prof] 2006

## BEYOND FUNCTION: PRETORIA STATION INTERCHANGE AND CIVIC SQUARE

Mbasa Xolisa Tshombe

This dissertation is submitted in partial fulfillment of the requirements for the degree of Master of Architecture (Professional) in the Faculty of Engineering, the Built Environment and Information Technology.

Study leader: Dr A. Osman  
University of Pretoria, Pretoria

November 2006

# DEDICATIONS

Dedicated to the memory of my father,  
and also to my ever loving grandmother - **Magaba**

I would like to sincerely express my gratitude to the following people and parties for their unconditional support and assistance during the process of preparing this dissertation.

Dabs (my second mother), Piwe, Siseko and Sivuyile (for providing much-needed moments of laughter), and my mother.

Khotso Moleko and the staff at KM Architects Inc. Karen from Urban Solutions, Marisa Friguglietti from Murray and Roberts, Nomsa Mtshwene from The Department of Transport, Jenny from Smartglass, Gus Sonnenberg, Nkateko Ndobe, Sphelele Nxumalo, and Phumlani Khuzwayo.

I thank my study leader Dr Amira Osman for her guidance, constructive criticism and patience. Professor Karel Bakker and Piet Vosloo.

Finally, I thank the Construction Education and Training Authority (CETA) for providing the necessary financial assistance towards the realisation of this dissertation.

# PROLOGUE

DEDICATION	i
ACKNOWLEDGEMENTS	
LIST OF ILLUSTRATIONS	vi
PROLOGUE	

## CHAPTER 1

# BACKGROUND

1.1 FOCUS AREA	1
1.2 HISTORICAL CONTEXT	5
1.3 THE BRIEF	11
1.4 SITE ANALYSIS	13
1.5 PROPOSED DEVELOPMENTS	20
1.6 LEGAL FRAMEWORK	23

## CHAPTER 2

# THEORY/PRECEDENT

2.1 THEORETIC PREMISE	30
2.2 CONTEMPORARY THEORY	32
2.3 PRECEDENT STUDY	38

## CHAPTER 3

# BASELINE DOCUMENTATION

3.1 SUSTAINABLE DEVELOPMENT	46
3.2 SUSTAINABILITY ASSESSMENT TOOLS	49
3.3 SOCIAL CONSIDERATIONS	51
3.4 ECONOMIC CONSIDERATIONS	53
3.5 ENVIRONMENTAL CONSIDERATIONS	55
3.6 BUILDING ENERGY ISSUES	56
3.7 SBAT ASSESSMENT	58
3.8 DERMOGRAPHICS	63

**CHAPTER 4**

DESIGN GENERATORS

4.1	DESIGN INFLUENCES	65
4.2	DESIGN CONCEPT	107
4.3	TECHNICAL INVESTIGATION	108

**CHAPTER 5**

TECHNICAL

5.1	TECHNICAL DOCUMENTATION	148
-----	-------------------------	-----

**REFERENCES**

SOURCES

	LIST OF REFERENCES	
--	--------------------	--

## 1.1

FIGURE 1.1.1	GLOBAL MAP	1
FIGURE 1.1.2	SOUTH AFRICAN MAP	2
FIGURE 1.1.3	CITY OF TSHWANE JURISDICTION	3
FIGURE 1.1.4	FOCUS AREA	3
FIGURE 1.1.5	SURROUNDING LANDMARKS	4
FIGURE 1.2.1	PRETORIA STATION PHOTOGRAPH OF 1934	7
FIGURE 1.2.2	AERIAL VIEW OF MARSHALLING YARDS	7
FIGURE 1.2.3	SURVEYOR GENERALS MAP OF 1911	8
FIGURE 1.2.4	PRETORIA STATION BUILDING IN 1914	8
FIGURE 1.2.5	UPDATED SURVEYOR GENERALS MAP OF 1932	8
FIGURE 1.2.6	1928 AUDIT BUILDING	8
FIGURE 1.2.7	SALVOKOP AERIAL PHOTOGRAPH OF 1937	9
FIGURE 1.2.8	PRETORIA STATION AND SQUARE CIRCA 1934	9
FIGURE 1.2.9	SALVOKOP AERIAL PHOTOGRAPH OF 1947	9
FIGURE 1.2.10	SUNKEN GARDEN BUILT FOR THE BRITISH ROYAL VISIT OF 1947	9
FIGURE 1.2.11	OLD NZASM PRINTING STORAGE BUILDING	10
FIGURE 1.2.12	SHOSHOLOZA MEYL TICKET OFFICE	10
FIGURE 1.2.13	THE INCLUSION OF LUXURY LINERS	10
FIGURE 1.3.1	INTERSITE LOGO	11
FIGURE 1.3.2	GAUTENG PROVINCIAL GOVERNMENT LOGO	11
FIGURE 1.3.3	BLUE IQ LOGO	11
FIGURE 1.3.4	CITY OF TSHWANE METROPOLITAN LOGO	11
FIGURE 1.3.5	PRETORIA STATION VIEWED FROM PAUL KRUGER STREET	11
FIGURE 1.3.6	BOSMAN TAXI STATION	12
FIGURE 1.3.7	BOSMAN TAXI STATION WITH DAIRY MALL VISIBLE	12
FIGURE 1.4.1	SITE IDENTIFICATION DIAGRAM	13
FIGURE 1.4.2	NORTHERN STEPPE CLIMATIC ZONE	14
FIGURE 1.4.3	GEOLOGY DIAGRAM FOR PRETORIA	14
FIGURE 1.4.4	MORPHOLOGY DIAGRAM FOR PRETORIA	14
FIGURE 1.4.5	SUN ANGLE DIAGRAM FOR THE SITE	15
FIGURE 1.4.6	WIND ROSE DIAGRAM FOR THE SITE	15
FIGURE 1.4.7	WIND DIRECTION DIAGRAM FOR THE SITE	15
FIGURE 1.4.8	KGOBOKANENG TAVERN	16
FIGURE 1.4.9	WORLD WAR ONE MEMORIAL	15

## 1.1

FIGURE 1.4.10	SUNKEN GARDEN	16
FIGURE 1.4.11	NL TOURS OFFICES	16
FIGURE 1.4.12	OLD STATION MASTERS HOUSE	16
FIGURE 1.4.13	OLD NZASM PRINTING STORAGE BUILDING [INTERSITE OFFICES]	16
FIGURE 1.4.14	1928 AUDIT BUILDING [LUXLINER OFFICES]	16
FIGURE 1.4.15	OLD COACH WASHING SHED	16
FIGURE 1.4.16	PRETORIA STATION BUILDING	16
FIGURE 1.4.17	BLUE TRAIN ENTRANCE	16
FIGURE 1.4.18	SALVOKOP BRIDGE	16
FIGURE 1.4.19	RAILWAY LINES	16
FIGURE 1.4.20	SHOSHOLOZA MEYL TICKET OFFICE	16
FIGURE 1.4.21	BOSMAN TAXI STATION	17
FIGURE 1.4.22	VICTORIA HOTEL	17
FIGURE 1.4.23	PAUL KRUGER STREET AXIS	17
FIGURE 1.4.24	BUTTERFIELD SHOP	17
FIGURE 1.4.25	RAILWAY STREET EDGE	17
FIGURE 1.4.26	BELGRAVE HOTEL	17
FIGURE 1.4.27	SAR [SOUTH AFRICAN RAILWAYS] HOUSES	17
FIGURE 1.4.28	STATION VIEW FROM SALVOKOP	17
FIGURE 1.4.29	STAFF PARKING	17
FIGURE 1.4.30	POP-UP BUILDING	17
FIGURE 1.4.31	KOCH STREET	17
FIGURE 1.4.32	SALVOKOP ACCESS RAMP	17
FIGURE 1.4.33	SCHEIDING STREET BUS TERMINUS	17
FIGURE 1.4.34	BOSMAN TRAIN STATION	17
FIGURE 1.4.35	FIGURE-GROUND DIAGRAM	18
FIGURE 1.4.36	PROMINENT ROUTES AND ROUTE DIRECTION	18
FIGURE 1.4.37	PROTECTED BUILDINGS	18
FIGURE 1.4.38	LAND USE DIAGRAM	18
FIGURE 1.4.39	CURRENT PUBLIC TRANSPORT LAYOUT DIAGRAM	19
FIGURE 1.4.40	PROPOSED PUBLIC TRANSPORT LAYOUT DIAGRAM	19
FIGURE 1.4.41	PEDESTRIAN MOVEMENT DIAGRAM	19
FIGURE 1.4.42	VEHICULAR MOVEMENT ROUTES DIAGRAM	19
FIGURE 1.4.43	PUBLIC TRANSPORT MOVEMENT ROUTES	19



## 1.1

FIGURE 1.5.1	LUXURY LINERS	20
FIGURE 1.5.2	PROPOSED NEW LUXURY LINER TERMINUS LAYOUT	20
FIGURE 1.5.3	FOOD COURT VIEW	20
FIGURE 1.5.4	SOUTH EAST AERIAL VIEW	20
FIGURE 1.5.5	HAWKER STALLS	20
FIGURE 1.5.6	GAUTRAIN ROUTE MAP	21
FIGURE 1.5.7	STAKEHOLDERS	21
FIGURE 1.5.8	GAUTRAIN COACH EXTERIOR ARTIST'S IMPRESSION	21
FIGURE 1.5.9	GAUTRAIN COACH INTERIOR ARTIST'S IMPRESSION	21
FIGURE 1.5.10	GAUTRAIN COACH IN MOTION	21
FIGURE 1.5.11	PRETORIA STATION GAUTRAIN ALIGNMENT	21
FIGURE 1.5.12	CENTURION STATION ARTIST'S IMOPRESSION	21
FIGURE 1.5.13	FREEDOM PARK	22
FIGURE 1.5.14	FREEDOM PARK DEVELOPMENT FRAMEWORK	22
FIGURE 1.6.1	TSHWANE ISDF 2005 FOCUS AREAS DIAGRAM	23
FIGURE 1.6.2	CATALYST PROJECTS DIAGRAM	23
FIGURE 1.6.3	OLD TAXI VEHICLES	25
FIGURE 1.6.4	NEW TAXI VEHICLES	25
FIGURE 1.6.5	ZONING DIAGRAM	26
FIGURE 1.6.6	HERITAGE FABRIC DEVELOPMENT DIAGRAM	27
FIGURE 1.6.7	PRECINCT ZONES DIAGRAM	28

## 2.1

FIGURE 2.1.1	POORLY MAINTAINED SUNKEN GARDEN	31
FIGURE 2.1.2	INTRUSIVE PARKING	31
FIGURE 2.2.1	CONSTITUTIONAL HILL	32
FIGURE 2.2.2	WALTER SISULU SQUARE	32
FIGURE 2.2.3	APARTHEID MUSEUM	32
FIGURE 2.2.4	FREEDOM PARK	32
FIGURE 2.2.5	FREE-STANDING BUILDING	33
FIGURE 2.2.6	WALKING CITIES	33
FIGURE 2.2.7	PEDI VILLAGE ISOMETRIC	34

## 2.1

FIGURE 2.2.8	PEDI VILLAGE PLAN	34
FIGURE 2.2.9	DECORATIVE MOTIFS	35
FIGURE 2.2.10	TYPICAL HOMESTEAD LAYOUTS	35
FIGURE 2.2.11	TYPICAL ZULU VILLAGE LAYOUT	36
FIGURE 2.2.12	URBAN PLANNING DIAGRAM	37
FIGURE 2.3.1	LUCERNE STATION MAIN FACADE VIEW	38
FIGURE 2.3.2	LUCERNE STATION CONCRETE COLUMNS VIEW	38
FIGURE 2.3.3	LUCERNE STATION ROOF DETAIL	38
FIGURE 2.3.4	LUCERNE STATION ENTRANCE	38
FIGURE 2.3.5	NORTH GREENWHICH TRANSPORT INTERCHANGE AERIAL VIEW	39
FIGURE 2.3.6	NORTH GREENWHICH TRANSPORT INTERCHANGE PLAN	39
FIGURE 2.3.7	NORTH GREENWHICH TRANSPORT INTERCHANGE SECTION	39
FIGURE 2.3.8	SA EMBASSY IN BERLIN PLAN	40
FIGURE 2.3.9	SA EMBASSY IN BERLIN BUILDING DETAIL	40
FIGURE 2.3.10	SA EMBASSY IN BERLIN ATRIUM	40
FIGURE 2.3.11	SA EMBASSY IN BERLIN <i>LITEMA</i> PLASTER PANEL	40
FIGURE 2.3.12	SA EMBASSY IN BERLIN REAR GARDEN	40
FIGURE 2.3.13	SA EMBASSY IN BERLIN SECTION	40
FIGURE 2.3.14	FEDERATION SQUARE NIGHT PANORAMA	41
FIGURE 2.3.15	FEDERATION SQUARE SITE PERSPECTIVE	41
FIGURE 2.3.16	FEDERATION SQUARE LIVE EVENTS	41
FIGURE 2.3.17	FEDERATION SQUARE RESTAURANTS	41
FIGURE 2.3.18	FEDERATION SQUARE SITE PANORAMA	41
FIGURE 2.3.19	METRO MALL FACADE TREATMENT	42
FIGURE 2.3.20	METRO MALL ENTRANCE ARTICULATION	42
FIGURE 2.3.21	METRO MALL ENTRANCE TOWER SCULPTURED STEELWORK	42
FIGURE 2.3.22	METRO MALL GROUND PLAN	42
FIGURE 2.3.23	TUKS FACULTY OF LAW BUILDING GROUND PLAN	43
FIGURE 2.3.24	TUKS FACULTY OF LAW BUILDING SOUTH EAST VIEW	43
FIGURE 2.3.25	TUKS FACULTY OF LAW BUILDING LIBRARY INTERIOR	43
FIGURE 2.3.26	TUKS FACULTY OF LAW BUILDING FACADE DETAIL	43
FIGURE 2.3.27	TUKS FACULTY OF LAW BUILDING NORTH EAST VIEW	43
FIGURE 2.3.28	MARY FITZGERALD SQUARE PANORAMA LOOKING TOWARDS THE WEST	44
FIGURE 2.3.29	MARY FITZGERALD SQUARE GENEROUS WALKWAY	44
FIGURE 2.3.30	MARY FITZGERALD SQUARE LIGHTS	44
FIGURE 2.3.31	MARY FITZGERALD SQUARE DRINKING FOUNTAIN	44
FIGURE 2.3.32	MARY FITZGERALD SQUARE WOODEN CARVED SCULPTURES	44

## 3.1

FIGURE 3.1.1	INTERGRATED APPROACH TO SUSTAINABLE BUILT ENVIRONMENT DIAGRAM	46
FIGURE 3.1.2	3 SYSTEMS DIAGRAM	48
FIGURE 3.7.1	SBAT RESULTS CHART DIAGRAM	62
FIGURE 3.8.1	LAND PROVINCIAL ALLOCATION CHART	63
FIGURE 3.8.2	POPULATION PROVINCIAL ALLOCATION CHART	63
FIGURE 3.8.3	PERCENTAGE OF PEOPLE AGED 20 AND OVER WITH NO EDUCATION CHART	63
FIGURE 3.8.4	PERCENTAGE OF PEOPLE AGED 20 AND OVER TERTIARY EDUCATION CHART	63

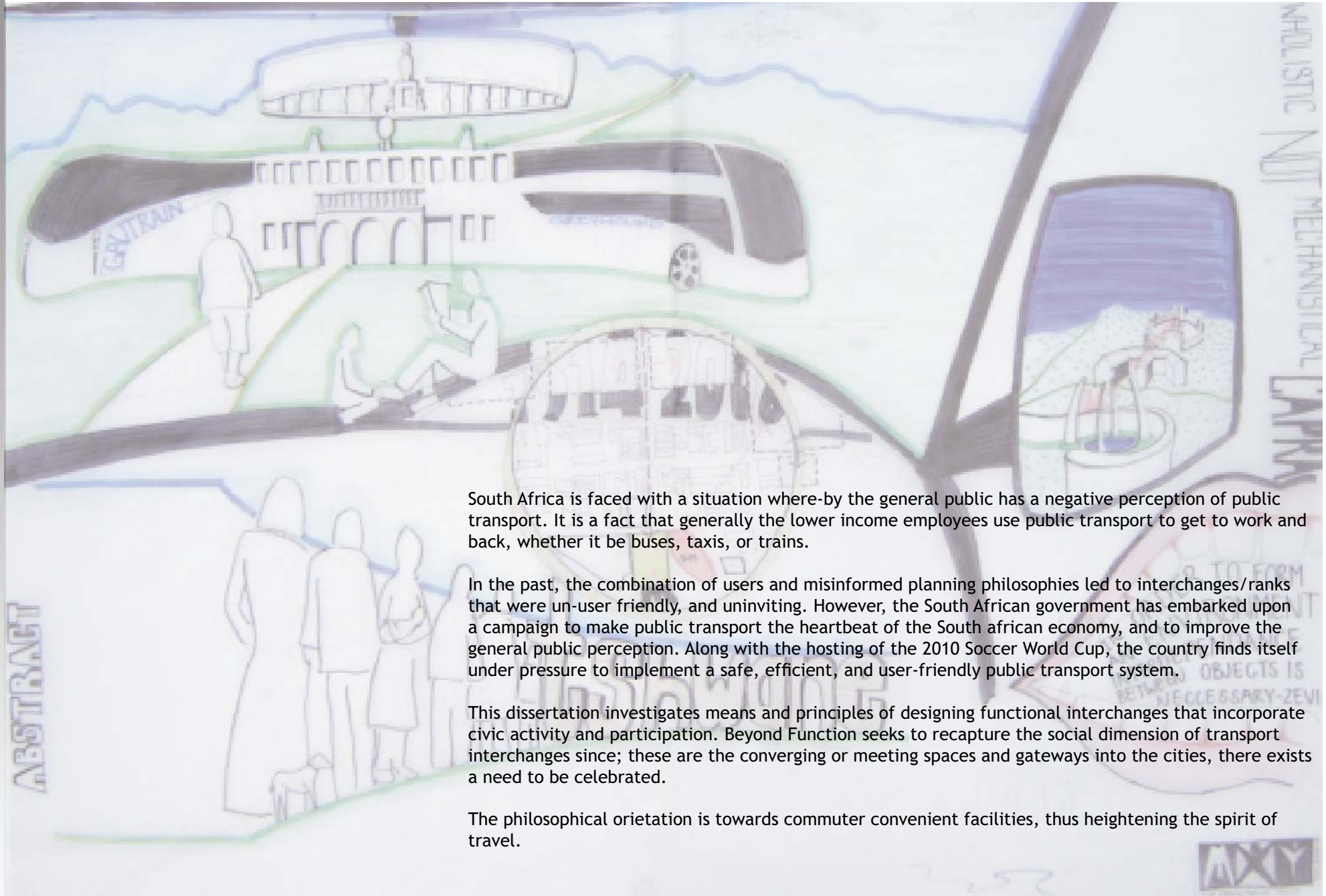

South Africa is faced with a situation where-by the general public has a negative perception of public transport. It is a fact that generally the lower income employees use public transport to get to work and back, whether it be buses, taxis, or trains.

In the past, the combination of users and misinformed planning philosophies led to interchanges/ranks that were un-user friendly, and uninviting. However, the South African government has embarked upon a campaign to make public transport the heartbeat of the South african economy, and to improve the general public perception. Along with the hosting of the 2010 Soccer World Cup, the country finds itself under pressure to implement a safe, efficient, and user-friendly public transport system.

This dissertation investigates means and principles of designing functional interchanges that incorporate civic activity and participation. Beyond Function seeks to recapture the social dimension of transport interchanges since; these are the converging or meeting spaces and gateways into the cities, there exists a need to be celebrated.

The philosophical orietation is towards commuter convenient facilities, thus heightening the spirit of travel.



# CHAPTER 1

Page 1-28

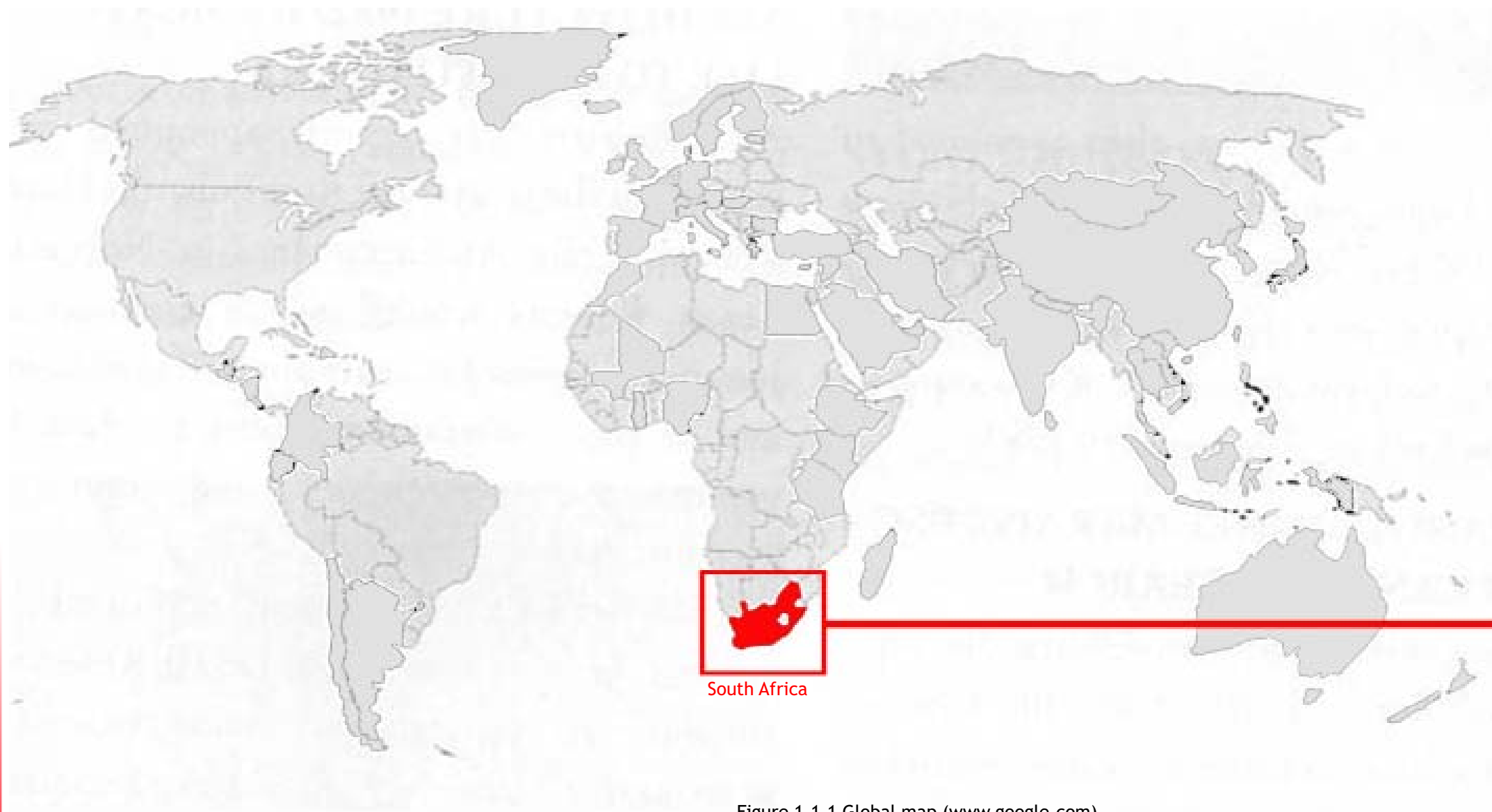

Figure 1.1.1 Global map (www.google.com)

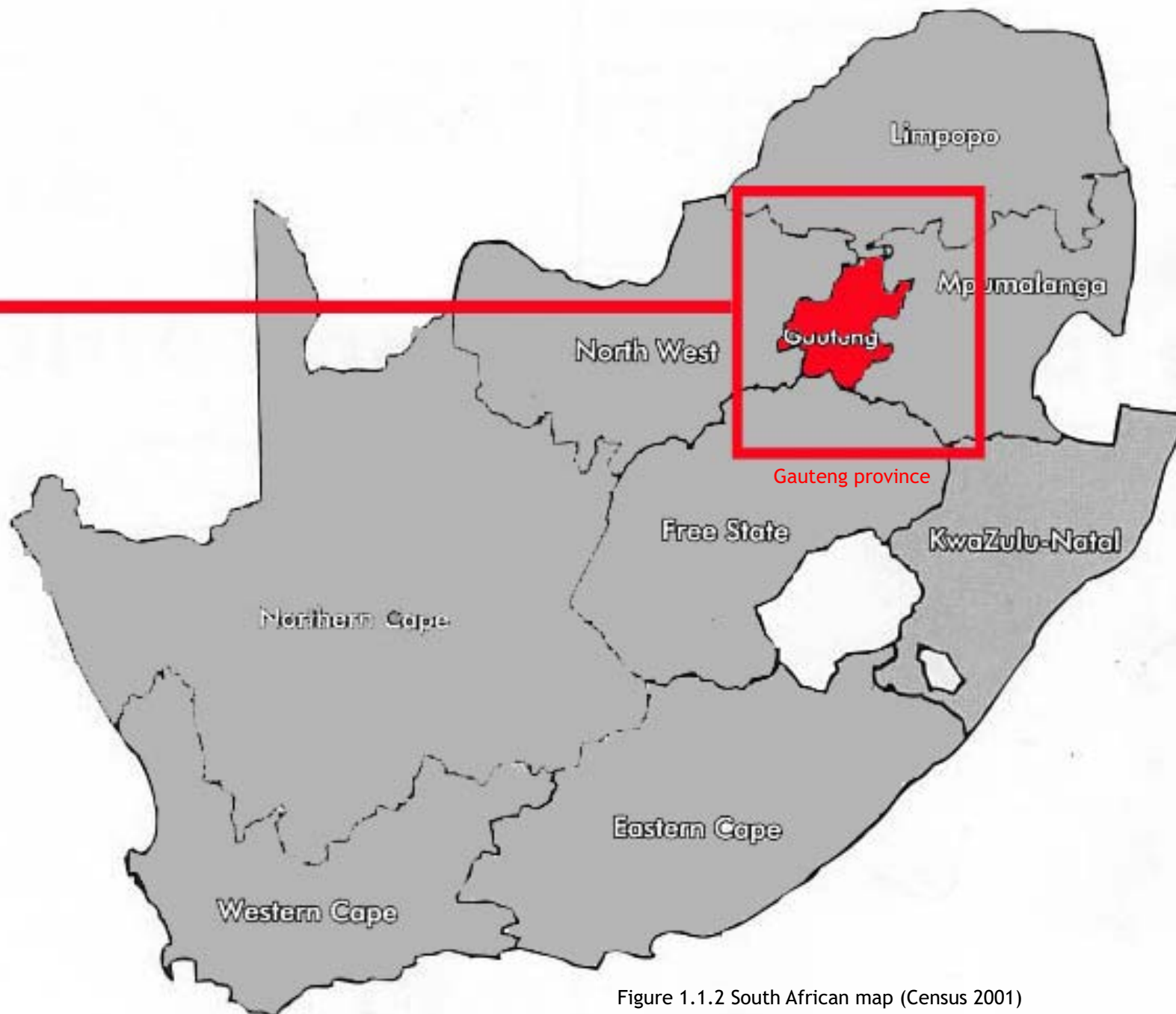

Figure 1.1.2 South African map (Census 2001)



Figure 1.1.3 City of Tshwane jurisdiction (GeoViewer)

The Pretoria station is the heart of the city of Tshwane’s network of a public transport. The station plays host to various inter-modal forms of public transport namely, trains, taxis and buses, covering both short and long distance destinations. While transport services cover the functional importance of the station; of remarkable significance however, is the rich layering of the city’s development history that it narrates. The station firmly asserts itself as a place of historical significance in the birth of the city. The activities of the station date back over a century to even before the 1880’s when the Nederlandse Zuid-Afrikaanse Spoorweg Maatschappij (NZASM) was established to build the Pretoria-Delagoa bay line (Wasserfall 1989:226). Considering the fact that the current station building was designed by Sir Herbert Baker, it is apparent that the Pretoria station is not just a station, but a chapter in the history books of the city of Tshwane’s political and developmental history, and that it is a valuable landmark for posterity.

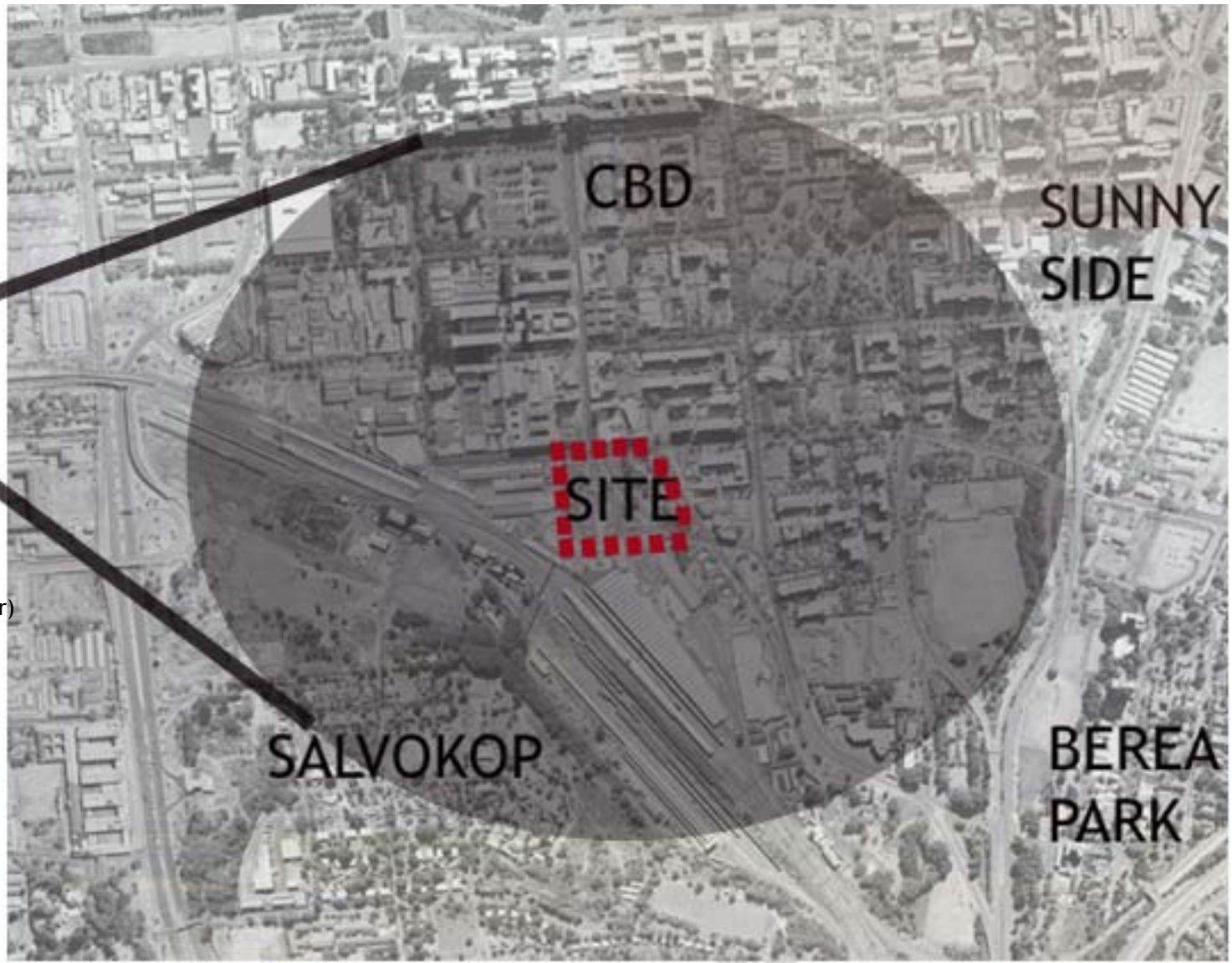

Figure 1.1.4 Focus area (GeoViewer)



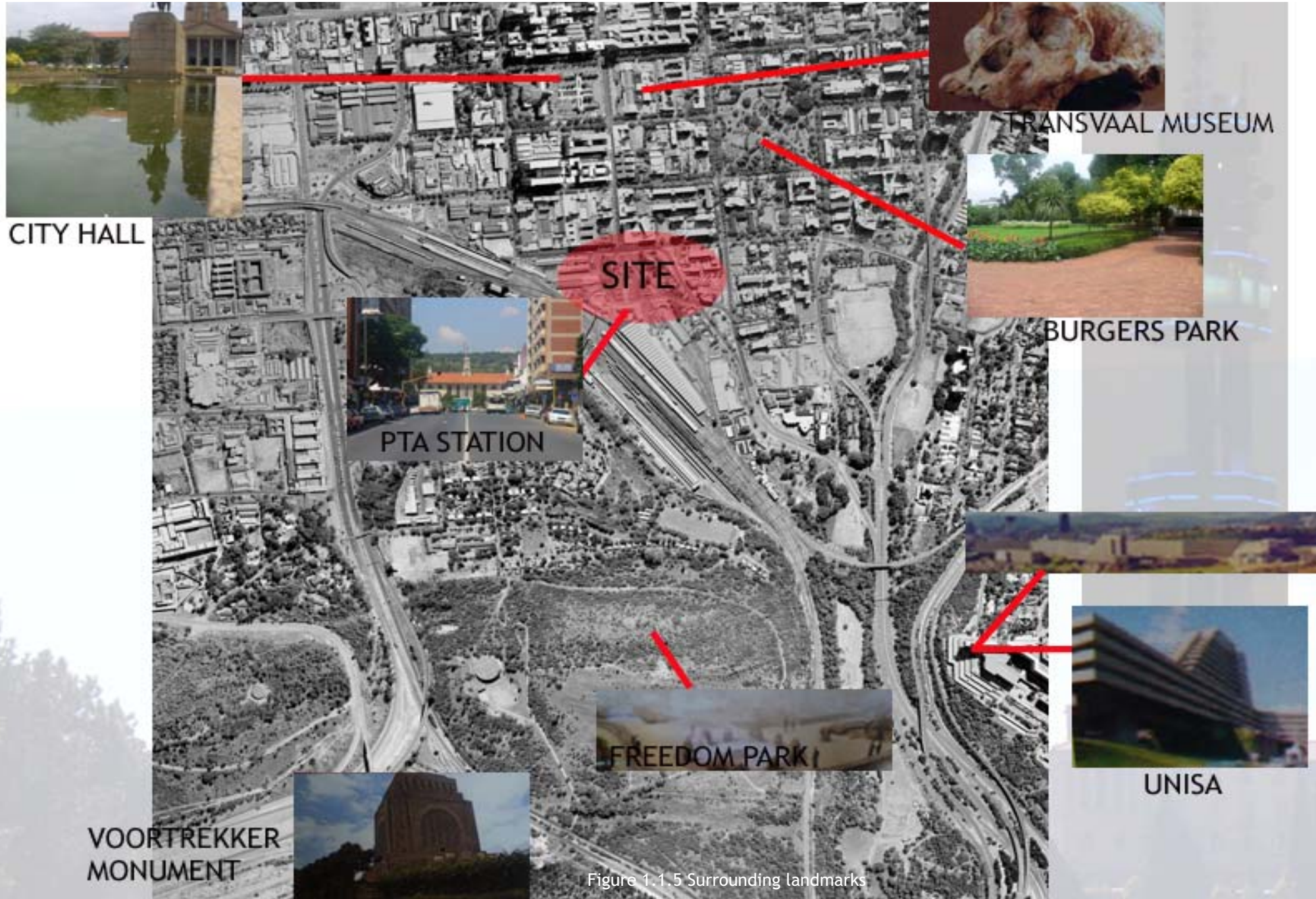

Figure 1.1.5 Surrounding landmarks

## HISTORIC AND PHYSICAL DEVELOPMENT OF THE STATION AND SURROUNDING AREAS

### HISTORIC DEVELOPMENT

#### SUMMARISED CONTEXT FOR THE DEVELOPMENT OF SALVOKOP HERITAGE SITE

The NZASM railway initiatives, which focussed on the hub of Salvokop before 1902, was the biggest single state driven infrastructure venture the Transvaal Republic ever undertook. The venture provided job opportunities for thousands of white and black citizens at the time, and made a huge contribution to the Zuid afrikaanse Republiek (ZAR) economy, in terms of revenue and of sustaining the all important mining industry and also the agricultural community. The increased mobility of labour, black and white, became the pillar on which the capitalist economy trusted. Control over the railway system dominated South African interstate politics up to the Anglo Boer War, and remained an important issue afterwards. During the Anglo Boer War the importance of the railways to the ZAR and the Empire was paramount. British troops were stationed there at various times between 1877 and 1902. After the Anglo Boer War Salvokop, under control of the Central SA Railway, expanded rapidly and became an even more important part of Pretoria's townscape. The buildings and infrastructure of the NZASM Nederlandse Zuid-Afrikaanse Spoorweg Maatschappij (NZASM) and the Central South African Rail/ South African Rail and Harbour (CSAR/SAR&H) also made a significant contribution to the economic well-being of Transvaal towns, and in this case Pretoria. The historical involvement of the railways with the needy section of the white population (*in lieu* of black) goes back to the days of the CSAR in 1907, and was solidified in JBM Hertzog's Pact Government in 1924.

The physical presence of the NZASM, CSAR, and SAR&H spread far beyond the confines of the Salvokop area south of the railroad track: The large goods yard, offices, townships, abattoir yard, recreational areas and hotels in the area indicate the large footprint of the railways on the ecology of the city. The railway line served the industries to the west and east of Pretoria, as well as the abattoir. Only after 1848, when the new Afrikaner nationalist government initiated the large Koedoespoort and Capital Park railway complexes as part of a gargantuan, culture-specific job creation initiative, did the large presence of Salvokop in Pretoria wane. During this time the railway fulfilled an important part in servicing the ISCOR development. The Pretoria station and railway also became an important link in a successful and efficient implementation of the Homeland strategy which included industrial relocation and controlled labour mobility. Despite renewal initiatives in Salvokop during 1974-1980/1, the quality of the area declined rapidly during 1981-2002.

Currently, Salvokop is the focus of a renewed urban revitalisation attempt, initially rooted in the IDP process and the Inner City Spatial Development Framework that evolved from this process, as well as the development initiatives forthcoming from Propnet (for the landowner Transnet), conjoined to the Freedom Park Trust framework proposal for Salvokop, and the Mayoral initiative to develop the area as an urban housing component. (Bakker 2004:2-3)

## A RELEVANT TIMELINE

- Pre-historic times: Elandspoot (east of Salvokop) used as migratory route.  
 15-1600: The 'Transvaal' Ndebele were the first occupants around Pretoria.  
 Pre-Voortrekker settlement of 'Pretoria': The Ndebele were followed by Bakgatla. A large settlement existed near [west of] Salvokop - removed by Pres P Kruger to Makau [Garankua]<sup>1</sup>.
- 1842 Voortrekker brothers Lukas and Gerhardus Bronkhorst establish the farm Elandspoot (named after Elandspoot between Bronberg/Railway/Timeball/Signal /Salvokop Hill on the west and Muckleneuk Hill on the east).
- 1855 On 16 November the town of Pretoria is formally proclaimed as the Transvaal capital.
- 1864 First post coach/cart service started at the Main station and later at Church Square).
- 1875 The ZAR was dependant on the Colonies for access to harbours. The need for a railway to the east was identified. Fund raising effort for a railway to Delagoa Bay started in 1875 by Pres Burgers - his efforts came to nothing.
- 1877 Annexation of the Transvaal. Pretoria becomes the seat of British control.
- 1880 Postmaster-General J A Vogel devised a scheme whereby the arrival and delivery of of the different mails could be signalled. Signals were hoisted from the peak of a telegraph signal staff placed on the summit of the hill north of the Elandspoot. 1880 Start of 1<sup>st</sup> Anglo Boer War.
- 1883 Pres Kruger of the restored ZAR revives the idea of the railway by procuring a loan for a rail concession in the Netherlands and gaining the right from Portugal to construct a line through Mozambique.
- 1886 Discovery of the main gold reef on the Rand provided capital for the ZAR railway venture, and initiated a railway 'race for the Rand' which Pres Kruger was determined to win in terms of the Delagoa Bay NZASM connection, at the cost of the Colonies. The railway aspirations of the South African states and colonies became the issue around which politics were to revolve for the next decade and more. For Kruger the line to Delagoa Bay was the essence of Transvaal independence (This independence was eroded by the Sivewright agreement of 1891 which, in turn for funds, the Cape Colony was given a large say in the running of the proposed railway line).
- 1887 The Nederlandsche Zuid-Afrikaansche Spoorweg-Maatschappij (NZASM) established on 21 June in Amsterdam after many years of problems raising the required funds in the money market.
- 1894 Completion of station buildings, central workshops (Imported pre-fab structure), sheds, a roundhouse and 12 rental dwellings for married and unmarried white employees, most of the latter situated south of the station yard. Further to the west a compound for black workers was erected.
- 1896 Completion of storage depot for printed matter (formerly a national heritage site).
- 1896 J Joffe's Hollandia Hotel on the corner of Scheiding and Paul Kruger Streets completed.

- 1899 Completion of Telegraph office building.
- 1900 Pretoria annexed by the British on 5 June 1900. Pres Kruger leaves for Machadodorp by special train. Regular train services stop. Second annexation of Transvaal in September 1900 during 2<sup>nd</sup> Anglo-Boer War (1899-1902). The railway systems of the NZASM and the PPSM (who supported the Boer war effort) were taken over by the Imperial Railway Company (IMR) on 12 Sept 1900 - local workers were declared prisoners of war if they did not sign the oath of neutrality, and foreign workers were deported<sup>1</sup>. The IMR Salvokop site was also used by the military as camp and housing. The CSAR established its headquarters in Johannesburg, and since then Pretoria has only been a base for railway and other transport related operations in the region north of Johannesburg. During this period the old NZASM and PPSM workshops were enlarged and later replaced with new facilities. Hollandia Hotel renamed 'Victoria Hotel'. Extra floor added before 1902<sup>2</sup>.
- 1902 After peace had been achieved in May 1902, the entire NZASM and PPSM network, together with the railway system of the Free State, became the Central South African Railways (CSAR).
- 1902 End of Anglo-Boer War.
- 1906 Completion of Findlay Reservoir (Started in 1905 - Named after Councilman Findlay) in Salvokop for municipal water provision - the first in Pretoria. Water comes from the Fountains Valley by means of a stone aqueduct.
- 1907 Institute Building erected<sup>1</sup> for the Berea Club (from 1890's) for use by Railway staff. Only sport facility of 'young' Pretoria.
- 1909 Erection of the CSAR Chief Mechanical Engineer's office [now called Popup] to the north of the site just west of the Koch St alignment.
- 1910 CSAR and Cape and Natal railway administrations merge to form the South African Railways and Harbours (SAR [ & H]).
- 1910 Foundation stone of the new station building designed by H Baker laid by Mr Hull in May 1910.
- 1912 Replacement of the NZASM passenger station when the new building designed by sir Herbert Baker is inaugurated. The original station buildings were demolished a few years later and the old public place on Scheiding St disappeared.
- 1920s Demolition of former NZASM station buildings.
- 1925 Re-erection of the statue of Pres P Kruger on Station Square in October 1925. A century after his birth - statue originally unveiled at Prince's Park in 1913)<sup>1</sup>.
- 1926 Hall added to north of the Berea Club<sup>2</sup>.
- 1929 Belgrave Hotel<sup>3</sup> designed in Art Deco style by Hoffman & Hoffman at Railway St 22. Hotel is part of the railway environment.
- 1912-50's The busiest era of the SAR&H operations in Salvokop - many new buildings are erected in the railway zone as well as in the railway camp. In 1928 the Railway Audit building was constructed by Pretice and Mackie, who were involved with the Union Buildings. In 1937 the Railways started refraining from building identical rows of houses, and started to disperse railway properties in other parts of town - many employees houses are to be found east of Railway Street.
- 1946 Sunken garden constructed at Pretoria Station before the Royal visit in 1947.
- 1950's The development of railway lines to the country districts, the founding of Moregloed as a second railway suburb besides Salvokop, and the establishment of large goods shunting and maintenance facilities in Pretoria West, Koedoespoort and Capital Park.
- 1956 Completion of new railway workshops at Koedoespoort (to replace the inadequate workshop facilities of the old NZASM/CSAR precinct - relocation of workshops to Koedoespoort ).
- 1958 The old NZASM head office buildings and Director's residence were demolished to make way for a modern office block for housing the headquarters of the SAR's northern region (Northern Transvaal). This building, named NZASM Building, was taken into use in 1963.
- 1960-70 The last Salvokop houses are built.
- 1976 Simon vd Stel Foundation requests conservation of NZASM Hof.
- 1978 Members of the Simon vd Stel Foundation witness the demolition of all the double-storey semi-attached houses in Second and Third Avenues.
- 1980 The NZASM Hof is renovated by the SAR&H.
- 1981 In 1981 the administrative organisation of the railways became known as the South Africa Transport Services (SATS) - SATS only became a public company on 1 April 1990 when Transnet Ltd was founded.
- 1990 Establishment of TRANSNET as a public company to manage railways, ports, pipelines, road transport etc. The Transnet era was characterised with a decrease in scale of the operations, closure of uneconomical lines and the Pretoria West Goods Yard just north-west of Salvokop.
- 2001 Paul Kruger Street Spine Spatial Framework establishes the Station precinct as a very important node in the central city. Pretoria Station is burnt down by angry commuters. Freedom Park Architects in Association draws up a development framework is drawn up for Freedom Park National legacy site on Salvokop - a draft urban design framework for the suburb below is part of the Freedom Park framework.
- 2002 Station building re-built. GAPP/MMA Architects appointed to draw up a spatial development framework for Salvokop for the TRANSNET/Freedom Park Trust/City of Tshwane client partnership. The Freedom Park development re-establishes the role of Salvokop as an urban precinct. International architects invited to enter a design competition for Freedom Park components.
- 2003 Salvokop Development Framework in progress - to be completed in 1<sup>st</sup> half of 2003.

(Bakker 2004:4-10)

## PHYSICAL DEVELOPMENT

### A NAMING OF THE ZONES AND ELEMENTS OF SALVOKOP

Although Salvokop is an urban township and an entity upon itself - and has been described in various ways through the decades - a few distinctive sub-precincts or zones could be currently discerned for the purposes of the historical and the urban analysis, and urban design to follow. Zones of the larger urban sector within which to Salvokop and its history are bedded, are also identified. The delineation of zones derives from aspects such as function, layout, types and age of buildings as well as connection with adjacent zones and other activity areas. For the urban design process to follow it is proposed that the zones impact on the delineation of precinct zones in the framework, and that the following names be used:

Zone A: NZASM Court - Defined by the NZASM houses and school.

Zone B: CSAR/SAR housing - Defined by CSAR layout and CSAR/SAR houses.

**Zone C: Workshop and marshalling, station and rail - Defined by existing and demolished railway workshop buildings and marshalling yard, the station complex and hotel, and the rail lines and ancillary structures to the east and south-east.**

Zone D: Compound - Defined by the layout of the former black compound.

Zone E: School - Defined by site of Jopie Fourie Primary School.

Zone F: 'Hillside' - Consists mainly of SAR houses in an area designed as an extension of the CSAR Section, but following a contemporary 'garden city' approach.

Zone G: Reservoir - Defined by the Findlay Reservoir.

Zone H: Koppie (Salvokop/Timeball Hill itself).

Zone I: Head office - Location of the former NZASM head office buildings.

Zone J: Berea/Central - New Belgrave Hotel, Berea Club). (Bakker 2004:3)

The Pretoria station site, the focus area, falls within the Zone C



Figure 1.2.1 Pretoria station photo of 1934. (Bakker)



Figure 1.2.2 Aerial view of marshalling yards. (Bakker)

## University of Pretoria etd, Tshombe MX (2007)

### HISTORICAL SPATIAL NARRATIVE OF THE PRECINCT DURING THE SAR&H PERIOD: 1910-1981

This period is described in three phases: a) 1911, b) 1932-7 and c) 1948. The later period after 1948 till the present was a period of decline of Salvokop, and no attention is given in terms of the historical description - All structures built after 1942 are younger than 60 years old.

#### THE SITE IN 1911

The Surveyor-General's [S-G] plan of 1911 is used to demonstrate the site at the beginning of the SAR&H period in 1910.



Figure 1.2.3 Surveyor general's map of 1911. (Bakker)



Figure 1.2.4 Sir Herbert Baker designed station building, completed in 1914. (Bakker)

### THE SITE IN 1932/7

#### THE 1932 PLAN:

One is immediately struck by the tremendous increase in structures in the main Works area (The north-western portion of Salvokop). The first block of Joubert St (currently Skietpoort) is now edged with structures on its northern edge, together with the buildings of the Native Compound on its southern side providing a very 'urban' entrance. (Bakker 2004:17)



Figure 1.2.5 Updated Surveyor general's map of 1932. (Bakker)



Figure 1.2.6 1928 Audit building.

THE 1937 AERIAL PHOTOGRAPH



Figure 1.2.7 Salvokop aerial photograph of 1937. (Bakker)

THE SITE IN 1947



Figure 1.2.9 Salvokop aerial photograph of 1947. (Bakker)



Figure 1.2.8 Pretoria station and square circa 1934. (Bakker)



Figure 1.2.10 Sunken garden built for the British Royal visit of 1947. (Bakker)

THE SOUTH AFRICAN TRANSPORT SERVICES (SATS) ERA 1981 TO 2002



Figure 1.2.11 Old NZASM printing store declared a national monument in 1981.



Figure 1.2.13 The inclusion of luxury liners at the station.



Figure 1.2.12 Shosholoza Meyl ticket office building.

A BRIEF SUMMARY OF THE STATION ACTIVITIES.

The period of 1981-2002, under the jurisdiction of the SATS, saw the enforcement of apartheid policies, the Pretoria station, was reserved as a 'Whites only' station, while the Bosman station, to the north west of the Pretoria station was reserved for 'Blacks.' Physical development around the station precinct continued along the north-western end where the dairy mall flourished. With the establishment of Transnet in 1992, and its take over of railways, ports, and road transport, the uses of the Pretoria station were expanded, by that time racial segregation had been abolished.

The Transnet management saw the introduction of the Blue train, Luxury liners, Maxi cabs, all of which appropriated separate portions of the station precinct space.

Currently the station is used by all the afore-mentioned, including rail commuters, however the issue of planning and space has reached a point of concern.

The station building is not in its original state, it was restored in 2002, after disgruntled commuters had burnt it down, the previous year.

## THE CLIENT

The client, Intersite, was formed in 1992, to manage and develop the property portfolio of the South African Rail Commuter Corporation Limited (SARCC) which comprises some 374 rail commuter stations, and some 4200 hectares of land in the major metropolitan areas of Johannesburg, Pretoria, Durban and Cape Town. ([www.intersite.co.za](http://www.intersite.co.za))

Intersite manages the Pretoria station and the entire Pretoria station precinct. Intersite, in partnership with the Gauteng Provincial Government (GPG), and the City of Tshwane Metropolitan Council have agreed to the development of the Station Interchange project. Station Interchange is the redevelopment of the existing station, by including a new **MULTI-FUNCTION BUILDING** along the north eastern end, incorporating a new taxi rank, a civic square, resource centre, and new offices for the Department of Transport, and leasable office space.

Blue IQ, on behalf of the GPG, and the City of Tshwane Metropolitan council shall provide funding for the initiative.

## STAKEHOLDERS



Figure 1.3.1 Intersite logo



Figure 1.3.2 GPG logo



Figure 1.3.3 Blue IQ logo



Figure 1.3.4 City of Tshwane Metropolitan council logo

## BENEFITING PARTIES

The implementation of station interchange will bring about convenience firstly, for taxi commuters. The long distance distance taxis currently at the Bosman rank will be relocated, thus improving upon the inter-modal functionality of the station precinct, and easier accessibility to such taxis. Local inhabitants, more especially students will be able to make use of the **resource centre**, which will be an extension of the Eskia Mphahlele Community library, combined computer skills training centre, and community meeting place. In addition the station square shall be redesigned to be more user friendly, and to become a place for congregating for televised public addresses and announcements.

The inclusion of shops, **restaurants** and other convenience facilities such as refresh facilities, a travel centre and car hire facilities shall be of benefit to travellers, and passer-by's. The taxi associations will also benefit by having properly planned taxi rank with the necessary amenities. Department of Transport will have access to new offices right in the heart of an inter-modal public transport node.

The development seeks to be convenient to daily commuters, whilst creating a **good first impression** for tourist and passers-by, as one of the gateways into the city.

## SITE SELECTION

The north-eastern end of the Station precinct was selected based upon its close proximity to the existing station building, and due to the fact that it lies across the square, opposite to where the new proposed Luxury liner terminus will be. Thus the location helps create the triangular **interdependence** link between the various modes of transport. Access is provided by the 3 lane Railway street on the eastern side, and the 5 lane Scheiding street on the northern side.



Figure 1.3.5 Pretoria station viewed from Paul Kruger street.



## ACCOMMODATION SCHEDULE

LOCATION	FUNCTIONS	SIZE
Shops	Travel and booking centre	107m <sup>2</sup>
	Car rental facility	95m <sup>2</sup>
	Hair salon	72m <sup>2</sup>
	Pharmacy	72m <sup>2</sup>
	Phone and electronics shop	72m <sup>2</sup>
Restaurants	ATM's	38m <sup>2</sup>
	Newscafe	324m <sup>2</sup>
	Steers	293m <sup>2</sup>
	Ice-cream parlour	189m <sup>2</sup>
	King Pie	233m <sup>2</sup>
Tourist attractions	Public transport museum	538m <sup>2</sup>
	Open-air Exhibition space	389m <sup>2</sup>
	Tourist information offices and curio shop	107m <sup>2</sup>
Information point	General information kiosk	24m <sup>2</sup>
Taxi rank	Queuing islands	
	Loading lanes	1600m <sup>2</sup>
	Hawker stalls	145m <sup>2</sup>
	Public Ablutions	482m <sup>2</sup>
	Hawker cooking and scullery	92m <sup>2</sup>
	Staff refresh facilities	58m <sup>2</sup>
Resource centre	Mini-Library	463m <sup>2</sup>
	Computer skills training centre	152m <sup>2</sup>
	Auditorium and discussion rooms	158m <sup>2</sup>
	e-facilities venue	107m <sup>2</sup>
Offices	Department of transport	4925m <sup>2</sup>
	Leasable office space	1327m <sup>2</sup>
Station Square	Public address space	6810m <sup>2</sup>
Parking	Thoroughfare	
	Underground parking for offices and taxis	8950m <sup>2</sup>



Figure 1.3.6 Bosman taxi station.



Figure 1.3.7 Bosman taxi station with dairy mall.



Figure 1.4.1 Site identification.

#### THE SITE

The station is located at the most southern tip of Paul Kruger Street. Scheiding Street forms the northern border of the site, while Railway Street completes the eastern boundary. To the immediate south lies Salvokop, separated by the rail tracks, and the west is defined by Scheiding Street Terminus, the local and long distance bus station. The Northern section away from the site is characterized by **mixed-use developments**, in the form of retail on the ground floor, and either residential or offices above. The land use creates a **vibrant**, lively **street usage**.

CLIMATIC INFORMATION

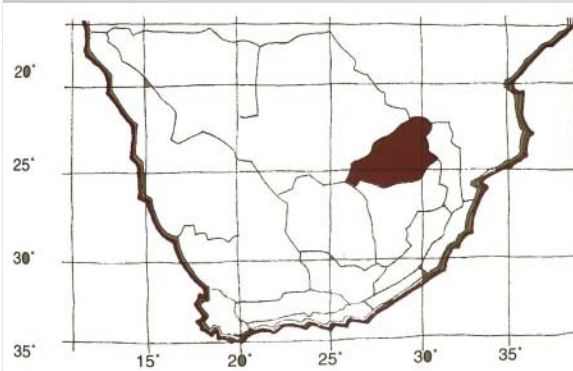

Figure 1.4.2 Northern Steppe climatic region. (Holm 1996)

Geographical Bearing

25,8 To 30,7 Deg. East  
22,0 To 25,9 Deg. South

This particular climatic region is characterized by distinct rainy and dry seasons with high daily temperature variations and strong solar radiation.

The average summer temperature is **24 degrees**, whilst winter is **12 degrees**. In order to combat the high daily temperature change, **thermal mass walls**, and floors are desirable, complimented by **lightweight insulated roofs**. (Holm 1996)

The average annual rainfall is 674mm, with the highest rainfall experienced during the summer season.

Humidity levels average 59%, which is within the general comfort zone of 30 - 65%.

SITE GEOLOGY

The Area lies within the Timeball Hill Formation of the Pretoria Group of the Transvaal Sequence. The dominant rock types are partly ferruginised **quartzites** with **shales**. The sedimentary members of the Pretoria Group are intruded by sills of the Transvaal Diabase. Sill intrusion is often along the contact between the shales and quartzites and often along distances of strike. (Salvokop SDF July 2003)

**Shale** is a common name for fine-grained varieties of sedimentary rock formed by the consolidation of beds of clay.

SITE MORPHOLOGY

The morphology of the site is classified under **Lowlands** with parallel hills.

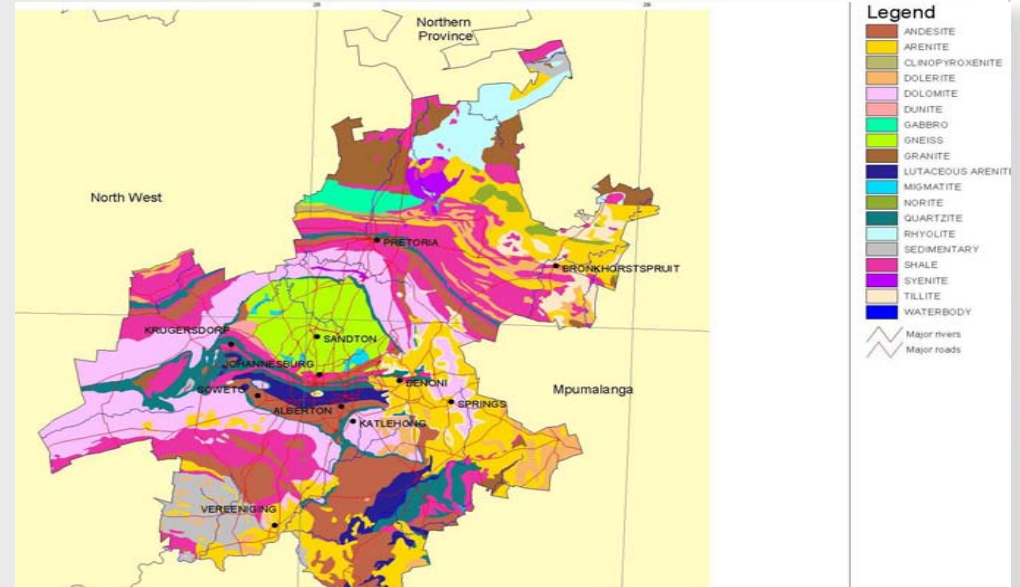

Figure 1.4.3 Geology diagram of Pretoria. (Council for Geosciences)

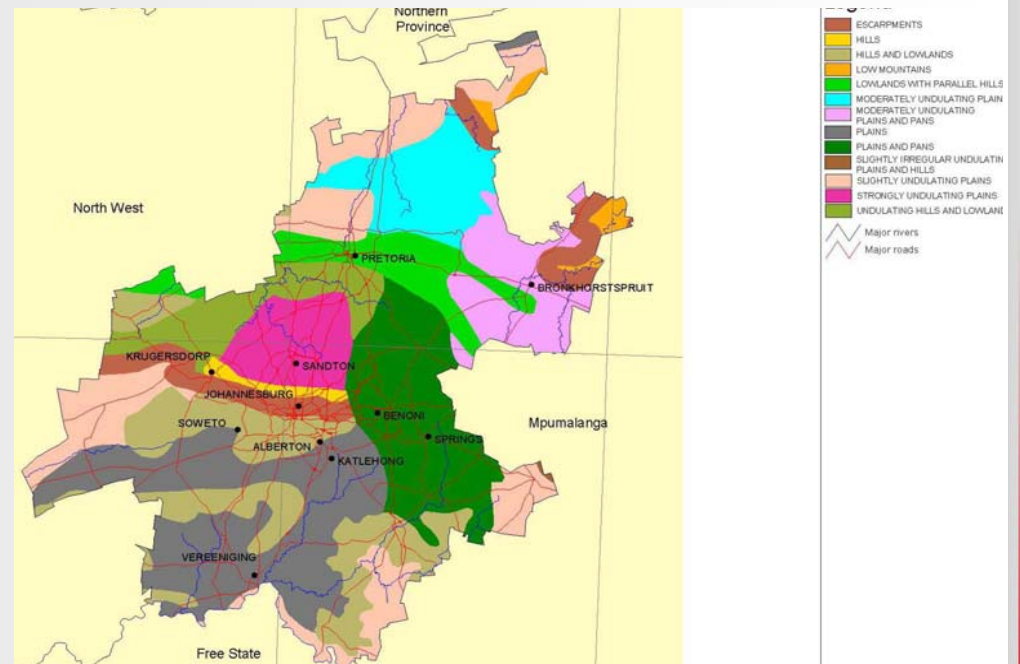

Figure 1.4.4 Morphology diagram of Pretoria. (Institute for soil, climate and water)

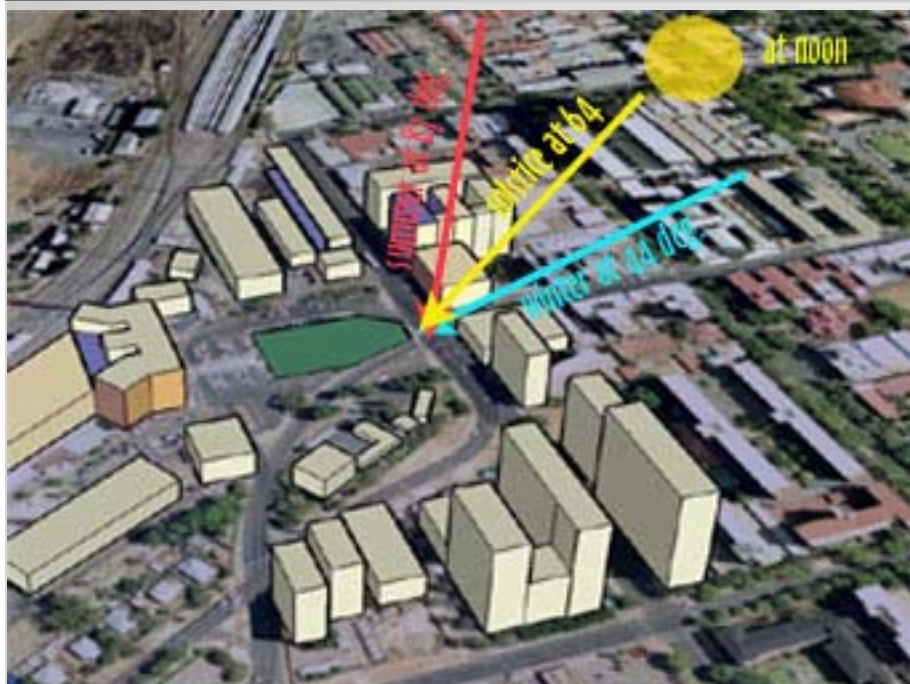

Figure 1.4.5 Sun angles for the site.

SUN ANGLES

SUMMER	87 degrees
SOLSTICE	64 degrees
WINTER	44 degrees

WIND DIRECTIONS

The predominant **summer** winds come from the east-south-easterly and east-north-easterly direction. **Winter** winds come primarily from the south westerly and north east directions.

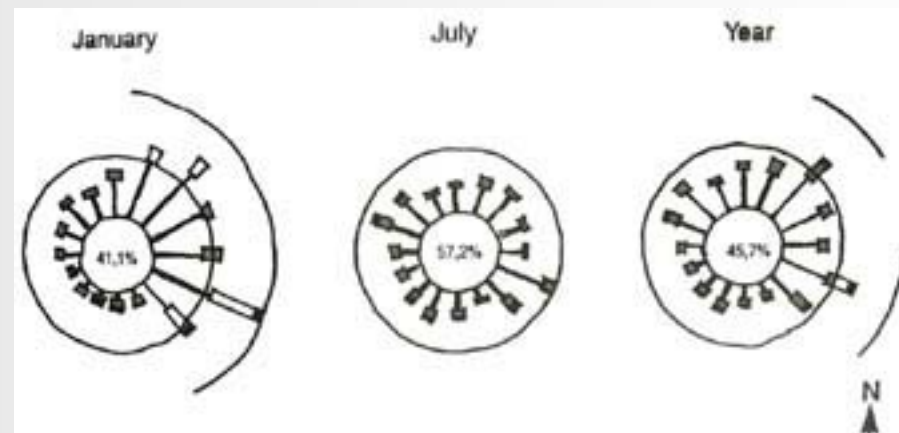

Figure 1.4.6 Wind rose for the site. (Holm 1996)

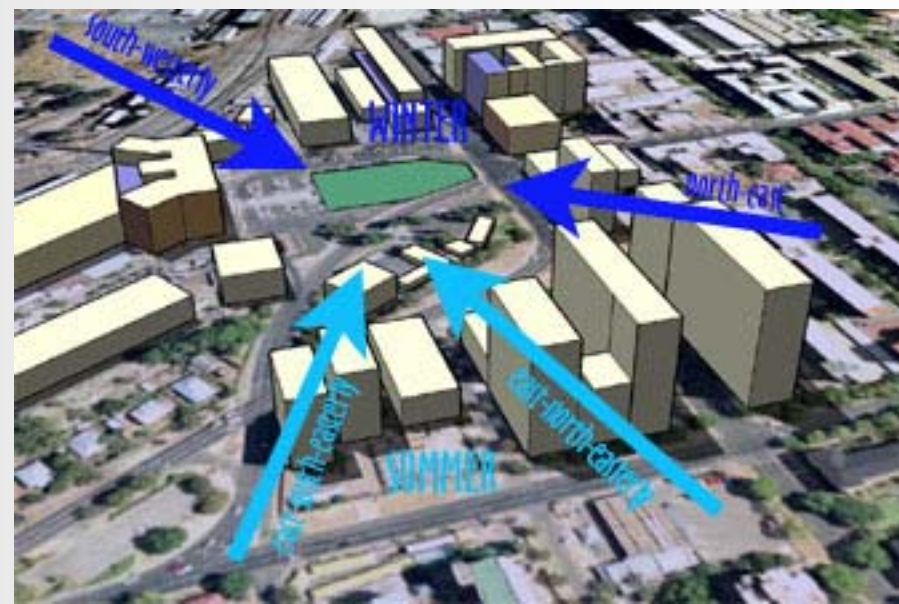

Figure 1.4.7 Wind directions for the site.



Figure 1.4.8 Kgbokaneng tavern



Figure 1.4.9 WW1 & WW2 memorial



Figure 1.4.10 sunken garden



Figure 1.4.11 NLTours offices



Figure 1.4.12 Old station masters house



Figure 1.4.13 Old NZASM printing storage, now Intersite offices.



Figure 1.4.20 Shosholoza Meyl ticket office



Figure 1.4.19 Railway lines



Figure 1.4.18 Salvokop bridge



Figure 1.4.17 Blue train entrance



Figure 1.4.16 Station building



Figure 1.4.14 1928 Audit building now luxury liner offices.



Figure 1.4.15 old coach washing shed



Figure 1.4.21 Bosman taxi station



Figure 1.4.22 Victoria hotel



Figure 1.4.23 Paul Kruger axis



Figure 1.4.24 Butterfield



Figure 1.4.25 Railway street edge



Figure 1.4.34 Bosman train station



Figure 1.4.26 Belgrave hotel



Figure 1.4.33 Scheiding street bus terminus



Figure 1.4.27 SAR Houses



Figure 1.4.32 Salvokop ramp



Figure 1.4.31 Koch street



Figure 1.4.30 POP-UP



Figure 1.4.29 Staff parking



Figure 1.4.28 View from Salvokop (Bakker)



Figure 1.4.35 Figure-ground diagram

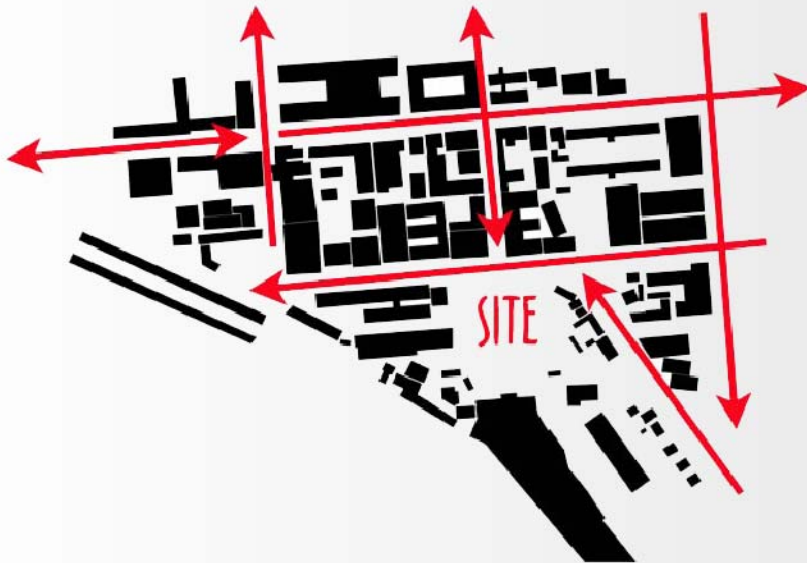

Figure 1.4.36 Prominent routes and route direction



Figure 1.4.37 Protected buildings



Figure 1.4.38 Land use diagram



Figure 1.4.39 Current public transport layout

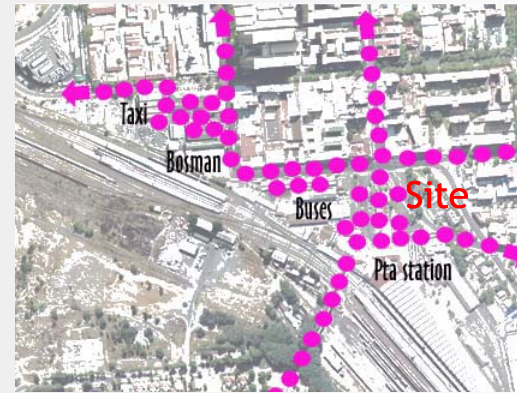

Figure 1.4.41 Pedestrian movement



Figure 1.4.42 Vehicular movement routes



Figure 1.4.40 Proposed public transport layout

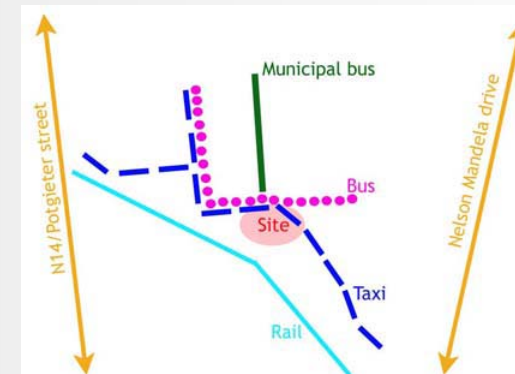

Figure 1.4.43 Public transport movement routes



## PROPOSED DEVELOPMENTS

### NEW LUXURY LINER TERMINUS

KM architects have been commissioned to design the new luxury liner terminus at the north western end of the station square. The design is essentially a triangular shaped layout that has an east-west axis that leads directly into the station square. Although a few structures are to be demolished to accommodate it, the existing Scheiding street bus terminus is retained including its current uses. The design philosophy seems to have prioritized the retention of the existing fabric.



Figure 1.5.1 Luxury liners



Figure 1.5.2 Proposed new luxury liner terminus layout (KM Architects Inc.)



Figure 1.5.3 Food court view (KM Architects Inc.)



Figure 1.5.4 South east aerial view (KM Architects Inc.)



Figure 1.5.5 Hawker stalls (KM Architects Inc.)

GAUTRAIN RAPID RAIL LINK PROJECT

In February 2000, Gauteng premier, Mbhazima Shilowa announced the Gautrain Rapid Rail Link project, commonly known as the Gautrain. R900 million was set aside for the implementation of this project, by the Gauteng MEC for finance and economic affairs, Paul Mashatile in 2005. Most recently the Minister of Finance, Trevor Manuel, announced in the 2006 budget speech that R7,1 billion would be set aside as a national contribution to the Gautrain project. (www.gautrain.co.za)

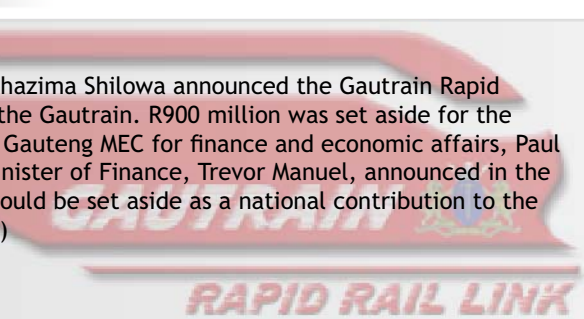

WHAT IS GAUTRAIN?

Gautrain is a Blue IQ2 initiative, one of 10 identified Spatial development Initiatives (SDI's) outlined by the Gauteng Provincial Government aimed at accelerating economic growth in the province. The project is aimed at alleviating the traffic load in the province's roads by providing a fast rail link between Tshwane and Johannesburg, and also linking Johannesburg International Airport (JIA) to Sandton. This rail link is to be an 80km long track network covering a total of 10 stations. The 3 main stations will be Pretoria station, Johannesburg International Airport, and Park station (JHB), 7 other satellite stations, located strategically within the route will complete the network. The distance between Tshwane and Johannesburg will be covered in approximately 35 minutes, at a train speed of between 160 and 180km per hour (kph).Gautrain will add another another dimension to the already existing transport system at the Pretoria station.



Figure 1.5.8 Coach impression (www.gautrain.co.za)



Figure 1.5.9 Coach interior (www.gautrain.co.za)



Figure 1.5.10 Coach in motion (www.gautrain.co.za)

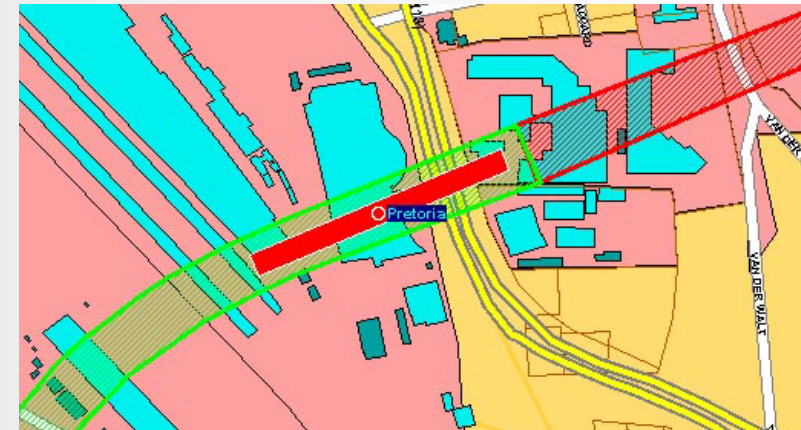

Figure 1.5.11 Pretoria station alignment (www.gautrain.co.za)



Figure 1.5.12 Centurion station artists impression (Murray and Roberts)



Figure 1.5.6 Gautrain route map (www.gautrain.co.za)



Figure 1.5.7 Stakeholders (www.gautrain.co.za)

## FREEDOM PARK DEVELOPMENT

The regeneration of Salvokop township, together with the development of Freedom park adds a tourism dimension to the Station precinct fabric. An opportunity of incorporating and anticipating the impact of this development is created at the Pretoria station.

### WHAT IS FREEDOM PARK?

Freedom Park is a visionary undertaking that will see South Africa boast a **world-class national heritage site** narrating the story of South Africa's **pre-colonial, colonial, Apartheid, and post-Apartheid** history. South Africa's history can be spanned dating back **3.6 billion years**, based on findings in Barberton, which is regarded as one of the most ancient findings of early life forms on earth. (Freedom Park Trust brochure)

### THE VISION

**To be a leading national and international icon of humanity and vision** (Freedom Park Trust Brochure).

### THE MISSION

**To provide a pioneering and empowering heritage destination that challenges visitors to reflect upon our past, improve our present and build on our future as a united nation.** (Freedom Park Trust Brochure).



Figure 1.5.13 Freedom Park (G.Asare-Bediako)



Figure 1.5.14 Freedom Park development framework (Final Draft Urban Design And Development Framework, 2003)

### TSHWANE INNER CITY DEVELOPMENT STRATEGY 2005

The Tshwane city council has embarked on a mission to make the city a formidable capital city, the leading capital city in Africa, and in time, a capital that will be on par with First World capital cities.

#### THE VISION:

To become the **leading** international African **capital city** of excellence that empowers the **community** to prosper in a **safe** and **healthy environment**.

#### AXIS OF EXPRESSION:

Three of the city of Tshwane’s capital anchors, namely: **Church square**, **The Union Buildings**, and **Freedom Park**, are to be linked by a system access termed, the **Government Boulevard**, and **Axis of Expression**. The proposed Government Boulevard will link the Union Buildings to Church Square. The Axis of Expression will link Church Square in a linear access along **Paul Kruger Street**, to the south, past Pretoria Station, and terminating in Freedom Park. The intention is to convert Paul Kruger Street, from Church Square, southwards, into a **pedestrian path**. Along with this proposal, it is envisaged that a variety of people’s squares will be created along the path, furthermore government buildings will also be clustered along such path, in close proximity to the squares.

#### ART IN PUBLIC PLACES PROGRAMME

The Tshwane Metropolitan Spatial Development Framework (MSDF) introduces the **Art-in-Public-Places-Programme**, whereby **1%** of the **budget** for all capital projects in the Inner City is allocated towards the **funding** of **public art elements** in the Inner City. The Axis of Expression is included in the Beautification and pedestrianisation of the strategic street grid which forms part of four catalytic interventions outlined by MSDF to kick-start the urban revival.

#### THE PRETORIA STATION

The Pretoria station is located almost at the most southern tip of the Tshwane inner city. It becomes a gateway into the city from the south direction. The **axis of expression** terminates at the station, and with the **Freedom park** development immediately to the south, it becomes evident that the station becomes an **intermediate point** which should contain qualities that uphold and are on par with the earmarked surrounding developments. The MSDF prioritises pedestrian movement over vehicular movement, as such the station needs to respond positively in accordance.



Figure 1.6.1 Focus areas (Tshwane inner city development strategy 2005 )

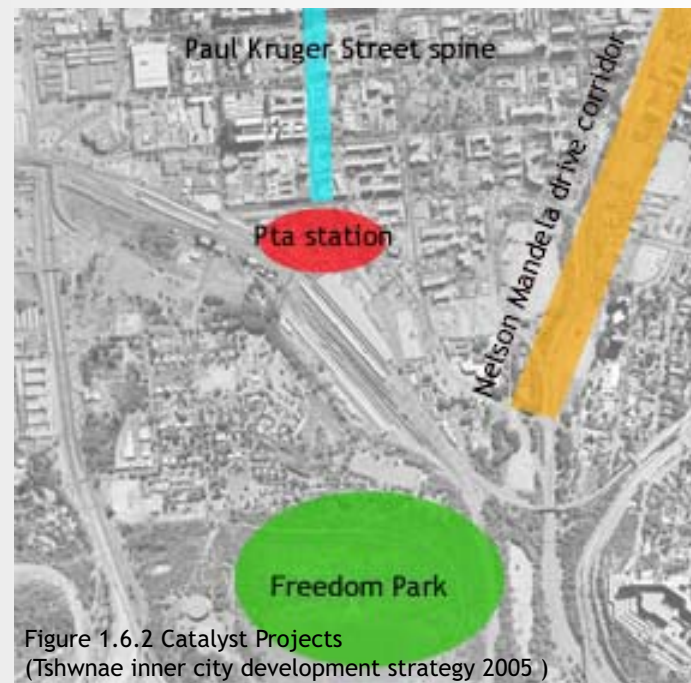

Figure 1.6.2 Catalyst Projects (Tshwane inner city development strategy 2005 )

## NATIONAL AND PROVINCIAL GOVERNMENT INITIATIVES

### DEPARTMENT OF TRANSPORT

#### THE VISION:

**Transport, the Heart Beat of the South African Economy**

#### THE MISSION:

Lead the development of intergrated transport systems by creating a framework and programme of sustainable policies, regulations and implementable models to support government strategies for economic, social and international development.

#### DEPARTMENT'S ACTION PLAN

The transport sector has increasingly been considered the "Heartbeat of the South African Economy" more so as we have witnessed consistent economic growth. The role of transport as an input sector in the economy is crucial and requires extensive investment in transport infrastructure particularly in the growth promoting sectors of freight logistics, aviation and maritime. Given the importance of transport in facilitating mobility in the second economy, further investment is required in the public transport sector to ensure the transformation of the current commuter system to an integrated public transport system. This should serve the entire South African society particularly focusing on improving effeciancy in transport services in urban areas and extending services to previously marginalized and rural areas. In order to improve transport operations, we aim to achieve the effective regulation of all modal operations and integration of the system to maximise both the benefits and nodal efficiencies.

Over the next three years the department will focus on the following:

- Key priority areas of delivery that bring about the greatest impact on the largest number of our clients in the shortest possible time;
- Strategic programmes that focus on the needs of our clients defined as internal and external stakeholders and particularly public transport users and the general public;
- Building capacity to monitor and oversee the public entities that report to the Minister of Transport; and
- Developing the regulatory systems and capacity required to ensure that operators in the transport sector meet the required safety and security standards as well as establishing a single economic regulator for the sector.

One of the key development areas that the Department has set targets for itself is the Public transport system.

#### PUBLIC TRANSPORT SYSTEM

The key challenges to improving the quality of transport operations and the broadening of access to affordable public transport include the continuation of the transformation and formalization of the minibus taxi industry through the taxi recapitalization project. Current statistics show that more than 60% of all commuter traffic is carried by the taxi industry in ageing fleet. It is expected that 60 000 of the oldest taxi vehicles will be scrapped over the next three years. The Department will also support provinces to ensure that adequate capacity and systems are in place to administer operating licenses for taxis, to monitor and enforce compliance with road traffic laws as well as taxi safety standards.

The roll-out and implementation programme will include the establishment of the Scrapping Agency and the scrapping of 10,000 of the oldest taxi vehicles in 2006. The Department is currently busy with the introduction of the new taxi vehicles, which meet the new safety which meet the new safety requirements. Furthermore, the Department is finalizing the conversion of permits to operating licenses, and measures for finalizing the regulation of the taxi industry.

Since the approval of the interim rail plan in 2005 we have proceeded with the restructuring of the passenger rail operations, the stepping up of investment in passenger rail infrastructure, prioritization of strategic rail corridors and appropriately targeting public transport subsidies. The consolidation of Metro Rail and the SARCC was achieved on the 1st of May 2006 with the major objective being the intergration of rail services to bring about efficiencies in the public rail system.

The Gautrain Rapid Rail Link is the most significant investment in passenger rail. This investment was made possible through a public - private partnership and is expected to deliver a new rail service between Johannesburg, Tshwane and the Johannesburg International Airport. Public investment for this project will be drawn from a national contribution in the form of a new conditional grant on the transport vote and a contribution by the Gauteng province. Construction is set to begin in 2006, to deliver 80km of rail track and more than 25km of tunnels, bridges and viaducts. The original Gautrain Rapid Rail Link was subsequently integrated into the existing rail network for Gauteng with clear indications for rail investment projects which will result in an enhanced and integrated network of rail commuter services. ([www.info.gov.za](http://www.info.gov.za))

TAXI RECAPITALIZATION PROGRAMME

The Department's taxi recapitalization programme is outlined in the table below. The taxi recapitalization programme is governments boldest move towards the implementation of safety and comfort within the public transport system. The objective is to improve the image of public transport and provide efficiency, with 2010 just around the corner, the state of public transport is being paid attention. Part of the hurdles and possible successes of the 2010 Soccer World Cup lie with the public transport system.

Measurable Objective: Scrapping of Old Vehicles

Objective	Outputs Descriptive (Deliverables)	Output Measure (KPI)	Time Frame	Measured Impact
Scrapping of 10 000 vehicles.	Administer the payment of the scrapping allowance and to facilitate agreements between transport authorities and taxi operators for the rationalization of saturated routes.	Total number of operators registered to exit the industry	31 Dec 2006	The total number of scrapped Old Taxi Vehicles per financial year.
	Scrap OTVs:	Number of operators receiving the R50 000 scrapping allowance:  The number of scrapped Old Taxi Vehicles: 500 in July 06 1000 in August 06 8500 over September to March 07 The number of taxi operators exiting the taxi industry	31 March 2007	Level of support for the rationalisation plans by municipalities (planning authorities) and taxi industry.
Establishment of an effective Scrapping and Administration Agency (SAA).	To initiate a user-friendly and efficient scrapping process. Exit from Taxi Operators who want to leave the industry	The number of applications received and processed by the SAA. The number of complaints received from taxi operators and commuters	Feb- April 2006	Removal of the most unsafe vehicles from the system Increased profit margins for the remaining operators.



Figure 1.6.3 Old Taxi Vehicles (www.info.gov.za)

The scrapping of the Old Taxi Vehicle (OTV) will see the introduction of the New Taxi vehicle (NTV). This vehicle type will be safer through the introduction of safety belts for each seat. They are more comfortable since they are designed to be slightly bigger and offer more headroom space than the existing taxi's, and have commuter comfort in mind.

Measurable Objective: Roll out of New Taxi Vehicles (NTV)

Objective	Outputs Descriptive (Deliverables)	Output Measure (KPI)	Time Frame	Measured Impact
Facilitate entry of New Taxi Vehicles compliant with Safety Requirements	Availability of NTVs in the market.	Increased roll-out of the NTV during the 2006/2007 financial year	July 2006 – March 2007	Enhanced competition and increased number of models available in the market
Popularise and ensure visibility (branding) of NTVs as a key element of the TRP	Launch of available vehicles in the Market	Improved levels of awareness of the progress of the TRP	May/June 2006	Increased awareness of number of safer New Taxi Vehicles purchased by taxi operators during 2006/07 and colour-coded vehicles



Figure 1.6.4 New Taxi Vehicles (www.info.gov.za)

SOCCER WORLD CUP 2010

The Department of Transport's 2010 Transport Action Agenda is a call to action, an articulation of the department's vision for the transport sector in 2010, with a particular eye on the peak in transport demand to accommodate the events of the 2010 FIFA World Cup™.

In order to facilitate the transport sector preparations for 2010, relevant authorities and host cities prepared priority statements defining their transport infrastructure requirements for 2010 and beyond. A new conditional grant was introduced in 2005/06 to fund some of the more urgent public transport infrastructure projects for host cities. It is anticipated that the public transport infrastructure grant will fund infrastructure investment of R3.5 billion in all municipalities over the medium-term. The Department has prepared a national transport action agenda and will consolidate all the 2010 transport plans into a single plan to ensure that the legacy remains beyond 2010. (www.info.gov.za)

PRECINCT ZONING

The site is zoned as Portion of 170 South African Railway special, Existing roads, and Existing Public square. The land is owned by Transnet.



Figure 1.6.5 Zoning diagram (Salvokop Development Framework 2003)

HISTORIC FABRIC DEVELOPMENT

The diagram below gives an indication of the significant development periods of the precinct.

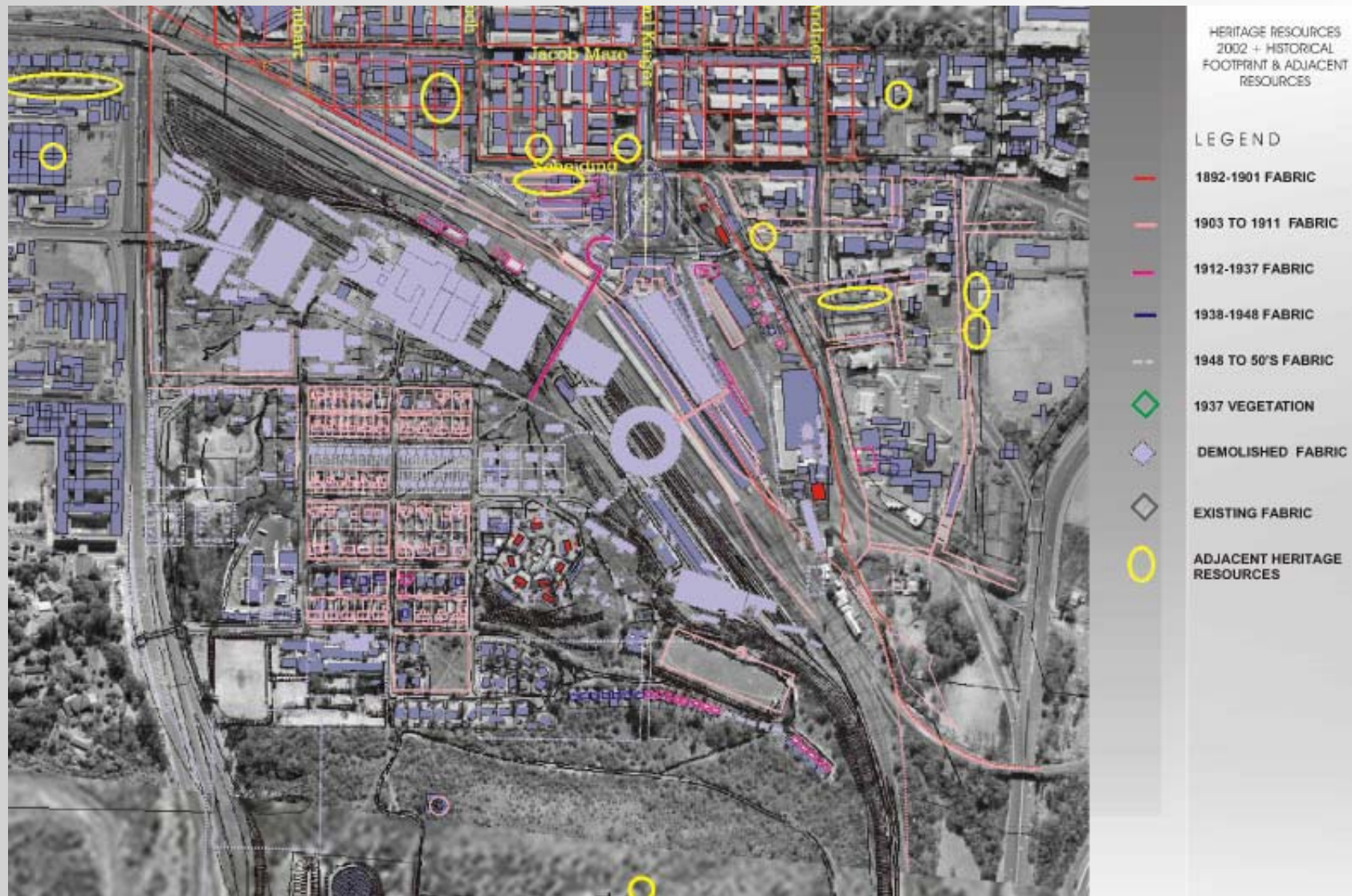

Figure 1.6.6 Heritage fabric development diagram (Salvokop Development Framework 2003)



PRECINCT ZONES

The site is classified under Cb, namely: Workshop, marshalling, station and rails area.

CULTURAL SIGNIFICANCE

The National Heritage Resources Act 25 of 1999, was passed by parliament as an act mandated with the task of conserving the heritage resources of the country. Under this act Salvokop precinct is adjudged to be of cultural significance under the following clauses:

- 3(3)(a) Importance in the community/pattern of South Africa's history.
- 3(3)(d) Importance in demonstrating the principal characteristics of a particular class of South Africa's natural or cultural places or objects.
- 3(3)(e) Importance in demonstrating particular aesthetic characteristics valued by community or cultural group.
- 3(3)(g) Strong or special association with a particular community or cultural group for social, cultural or spiritual reasons.

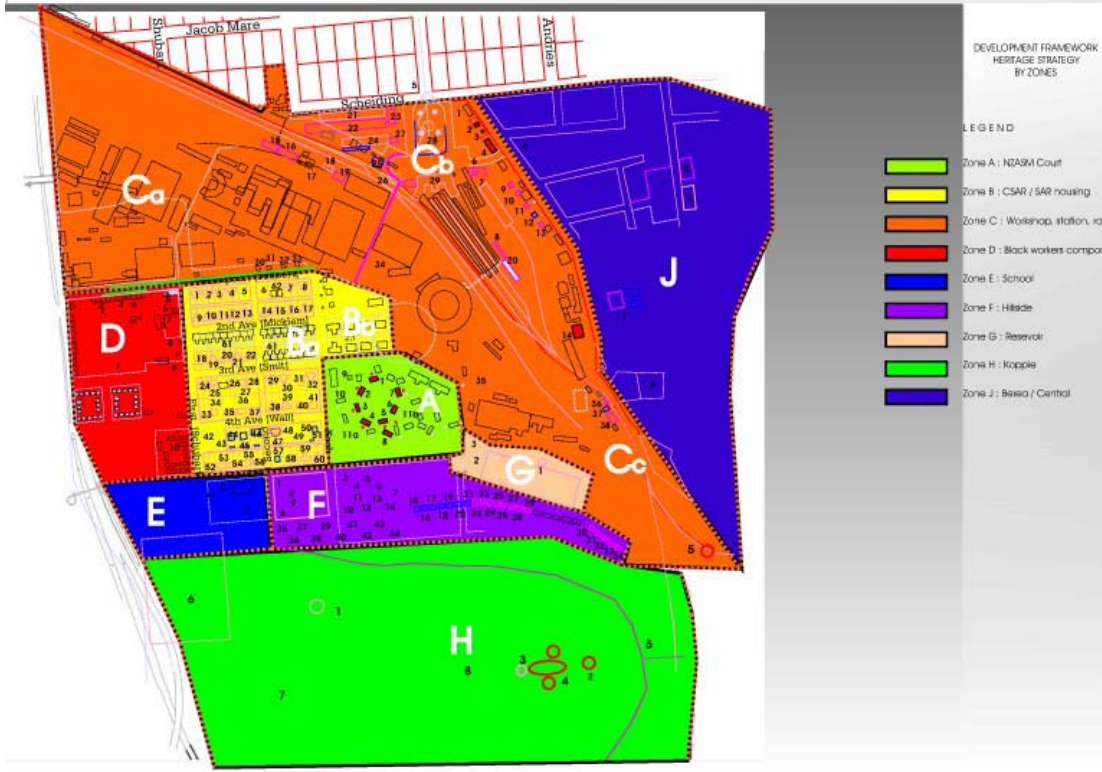
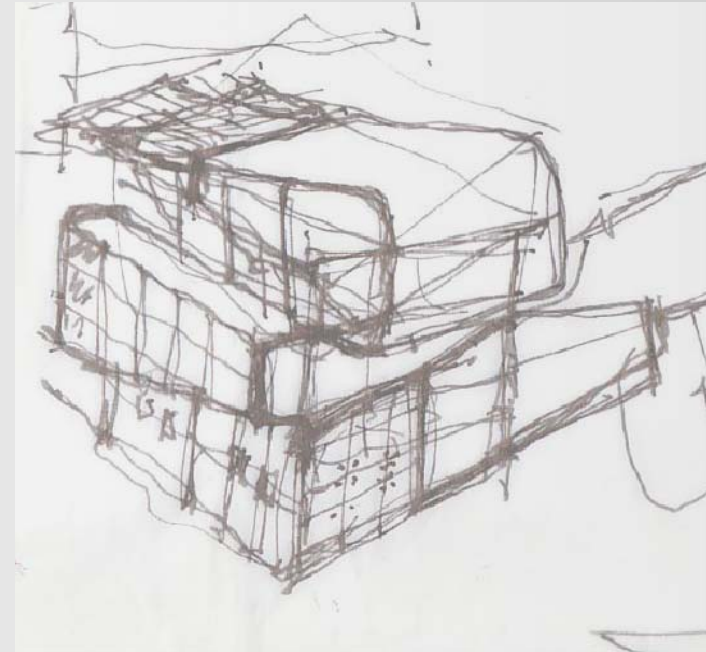

Figure 1.6.7 Precinct zones (Salvokop Development Framework 2003)

## CHAPTER 2

Page 29-44



#### APPROACH TO DESIGN DISCOURSE:

Auto [self] - Poiesis [making]

**Autopoiesis** - The 'self-making' pattern of organization of living systems.

The concept of Autopoiesis is the **philosophical** anchoring of the concerned dissertation. The concept was first introduced by Fritjof Capra in the book *Web of Life* in 1996. Autopoiesis entails a network wherein the function of each component is to participate in the production or transforming of other components within the network, such a network is self-sustained, by virtue of a continuous **closed cycle**. (Capra 1996).

The Pretoria Station Interchange can be viewed as the equivalent of a living system. Its very existence is to provide the shelter and infrastructure for a functional network of inter-modal public transport system to exist. It is 'selfmaking' in the organization and relation of its vital functions. The balance between the static and the transitory, the African and the European, the private and the public, the street and square, the structure and the large human traffic it accommodates validates the interchanges necessity and maintains the closed cycle system, consequently, rendering it self-sustainable.

## PROBLEM IDENTIFICATION

The Pretoria station is faced with the task of reorganization into a coherent and legible intermodal transport node. There exists a need for a new **Taxi rank**, designed to cater for the **New Taxi Vehicles** and to uphold the Department of Transport's quest to improve the **image** of public transport throughout the country. The introduction of the taxi rank enhances the intermodality of the station precinct. **Metrorail** trains already stop at the station, the proposed new **luxury liner terminus** is located in the same precinct, and the **Gautrain Rapid Rail Link** is proposed within the same vicinity.

To fully understand the crucial role that stations have potential to play in our cities, we need only shift focus to first world cities like Paris, London, New York, and so forth. The convenience of an organized public transport in First world cities has fostered a new perception of city **'gateways.'** The stations (subways) have for the most part replaced the traditional motor-route defined gateways. In the developing country of South Africa, we could soon see a similar trend, with the scheduled Government regulation of the public transport system, and the implementation of the **Gautrain**. Hence the design for future stations needs to anticipate such possibilities

We live in a network of **dynamic** actions and reactions; there is an almost tangible tension between the **fast-paced** free movement of the citizens against the backdrop of the **static** formal city layout and built form. The extremely transitory nature of our city life is largely supported by the city's public transport system.

A large population of the city of Tshwane's workforce, in sectors not regarded as **'professional'**, rely on public transport to reach work, and to return home daily on a daily basis. As a result of the ever increasing usage of public transport by pedestrians and the ever increasing traffic load by cars on our roads, it has become apparent that we need to reconsider, or **restructure** the current public transport system, firstly to be more organized and efficient, secondly, to comfortably cater for a broader variety of social class, and lastly, to be easier **accessible** to all forms of access (**foot, car, wheelchair**). If we are to create the spirit of a **pedestrian friendly city**, much attention should be focused on the revival and regeneration of the city's stations. The philosophy behind local transport interchanges requires a deviation from the conventional, purely pragmatic consideration to a more **socially interactive** outlook. Transport interchanges need to be more than just a monotonous boarding and climb-off act, but rather a **pleasant en-route experience** towards a destination. It needs to be the place where the homeliness [comfort] of home fuses with the business [energy] of the work environment translates into a continuous experience.

The Pretoria station is one of the few large scale inter-modal transport interchanges in the city. Its location, function and history suggest that it should be considered as the **heart of the city's network of public transport system**. There arises a need to clearly define, in a coherent manner, the capital city's main station. It is from here that public transport commuters and visitors will get a **first impression** of the city, hence the need for a grandeur structure, reflective of the city's capital status.

## AREAS OF CONCERN

Currently the Pretoria station is victim to poor planning, albeit by default. The current situation was brought about by the development around the precinct which has evolved throughout a century from the initially planned requirements as a result of the city's expansion from just the sole need of a railway station.

The planning layout around the station has become incoherent and disorientating, it has lost its visual appeal. With its location, the station building maintains a prime visual linear to Church square, and vice-versa. The growth of the city resulted in the fragmented development of the station precinct. There are various buildings, all together servicing various modes of transport, but as a whole, unstructured.

The result is that commuters walk distances of up to 370m, one way, from one form of transport mode to another.

The following areas need urgent attention:

**There is no clearly legible pattern of movement to guide boarders/commuters.**

**The public space is infringed upon by car parking.**

**The Bosman street taxi rank arose purely out of need, in the absence of logical planning, subsequently; it lacks basic public amenities, and sufficient roof covering.**

**The sunken garden is poorly-maintained and under-utilized.**

**Generally there is too much vehicular traffic, too close to the buildings on the site.**

**No public amenities catering for the square.**



Figure 2.1.1 Poorly maintained sunken garden

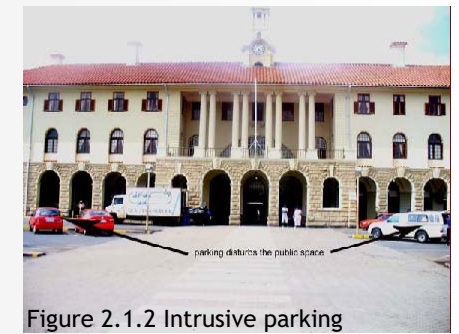

Figure 2.1.2 Intrusive parking

## CONTEMPORARY MOVEMENT IN ARCHITECTURE

Contemporary trends in global architecture favour, the move towards 'green' or 'sustainable' architecture, that is, architecture that is sensitive to the ecology of its context, and employing a cognitive awareness in the use of natural resources towards arriving at a resource efficient product. **Sustainable architecture** must among other considerations, drastically reduce the emissions of greenhouse gases especially carbon dioxide. (The Digest of South African Architecture 2002: 161). Lately, South Africa subscribes to such a movement, but moreover, seeks to find an architecture that reflects this country's **diverse cultures**, expressing and **reconciling** its rich **turbulent history**.

The search for such **architecture of identity** remains a hotly disputed issue within the architecture fraternity in South Africa. Such a quest informs the social, cultural, philosophical and functional base, but the real challenge lies in the **interpretation** and **implementation** of such findings into self **expressive built form**.

Examples of this quest of an architecture of identity, in public buildings are to be found in projects such as the *Constitution Hill*, *Apartheid Museum*, *Freedom Park*, and *Walter Sisulu Square*. South Africa is experiencing a phase concerned with defining a **regional architecture** (architecture of identity), that is, an architecture that is responsive to its context, resource efficient, and culturally and politically appropriate.

However, this situation is parallel to the current international tug of war between the idea of **Global** and **Regional** architecture respectively. On the one hand architects advocate standardized methods of construction globally; globalism; on the other hand, architects promote the concept of regionalism, which is informed primarily by culture, tradition, local materials and skills, all of which will be **unique** to a particular region.

The problem with global architecture is that it seems to produce edifices that look alike, hence surrendering an opportunity of considering an individualistic context unique appearance.

Notably, common to both global and regional architecture concepts is the idea of **sustainability**, though interpretation may differ slightly, for example global architecture attaches sustainability merely to the mitigation of the impact of the building on the environment, from the construction process through to the maintenance thereof. Regional architecture encompasses the aforementioned and further includes aspects specific to the particular region, such as **climate, culture, and heritage**. Regional architecture is prioritises focus on a **common humanism**, opposed to a common technology.

*"A recognition and a celebration of the natural, cultural, and historical uniqueness of different places and times."* (Dewar and Uytenbogaardt 1991)



Figure 2.2.1 Constitutional Hill (Aedes 2005)



Figure 2.2.2 Walter Sisulu Square (Aedes 2005)



Figure 2.2.3 Apartheid Museum (Aedes 2005)



Figure 2.2.4 Freedom Park (www.freedompark.co.za)

## AUTOPOEISIS AND ITS RELATION TO GLOBALISM AND REGIONALISM

In relation to people, the social philosophical concept of Autopoeisis is manifested through **communication**. Human societies in their variety are a reflection of **culture**, notably, culture is rooted in the identification or communion based on **language**. From this we can deduce that language is synonymous with culture.

*“It is certainly true that the social system is an organization like the individual that is bound that is bound together by a system of communication...”* Norbert Wiener (Capra 1996:62).

Since cultures define societies it is inevitable that the structures (habitat) that people erect to satisfy their functional needs will simultaneously **reflect** that particular culture’s beliefs. It is at this juncture that the issue of regionalism and globalism surfaces. On the one hand, civilisation has the technology and ability to create a *‘universal’* architecture, or architecture of a similar language across the globe - **Globalism**. On the other hand, there is the reality that the world is a conglomeration of different cultures located in their specific **context**, and that architecture should be representative of the particular culture and context it addresses - **Regionalism**.

## GLOBALISM

The industrial revolution of the late 19th Century initiated the manufacturing process of mass production, through the introduction of factories. Coupled with that were great advances in technology. The modern movement in architecture capitalised on the potential of the abundant **new technology** and possibilities of **mass production**, by steering towards **standardization** and modulation of building components. The objective of this approach would be the ability to design and construct a structure, based on standardized norms anywhere in the world, without the limitations of availability of materials in the particular context. This would yield a **universal** method of construction and to some extent a uniform appearance of buildings.

The concern however, is the lack of investigation into the contextual qualities and values such as culture, climate tradition and **heritage**. Paul Ricouer in *Universal Civilization and Cultures* of 1961 writes that *“Universalization constitutes a sort of subtle destruction of traditional cultures.”* (Frampton 1980: 313).

The height of the **modern movement** as envisioned by Ron Herron’s *Walking Cities* in 1964, although intended as the reconstruction after a nuclear war aftermath, reveals a disturbing alienation from the conventional *‘on the ground’* interaction of society. The structures are designed to adapt to various ground conditions but still remain visibly **alienated** and disconnected to context. Similarly, **free-standing buildings** advocated by Le Corbusier, one of the pioneers of the modern movement are attacked by both Roger Trancik and Edmund Bacon in *Finding Lost Space* (1986) and *Design of Cities* (1967) respectively, for being isolated to the **landscape**, **street**, and **people**.

Such a future in architecture appeared at the time to be quite fragmented and defiant of the very essence of social beings, which is interaction and contact.

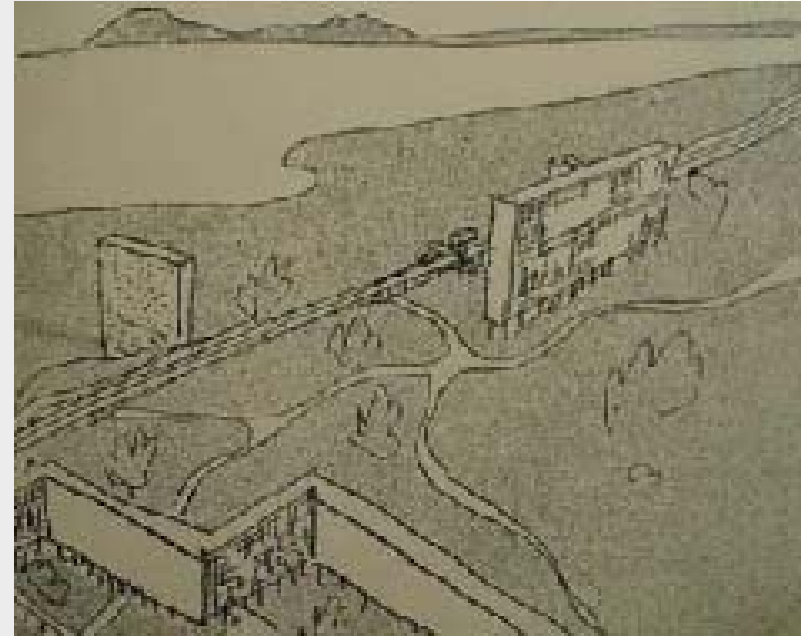

Figure 2.2.5 Free-standing buildings by Le Corbusier (Bacon 1967:217)



Figure 2.2.6 Walking Cities by Ron Herron (Frampton 1980:281)

## REGIONALISM

The aspiration to manifest **cultural, economic, and political independence** constitutes regionalism according to Kenneth Frampton in *Modern Architecture a Critical History* (1980).

**Regionalism** in architecture is most commonly associated with **vernacular** architecture. An analysis into vernacular architecture reveals that the generative concepts are rooted in the culture of the particular region. Anthropologist Hauser Schaublin echoes this point in the statement “*Building traditions are as much a specific cultural heritage of a group as is language and perhaps music*” (Capra 1997).

Language and region which translate into culture and context that define the concept of ‘**vernacular**’ however, the realisation of the concept into structure is partly governed by the availability of **materials** and construction technology. The infusion of **context** (topography and climate), **technology** (materials), and **tradition** (language and culture) define the ‘**Style**’ of a particular type of vernacular architecture.

‘It could be argued that a regionalist architecture will be generated by the designer directly responding to the following aspects in a place specific way: **climate, materials, site, defence, economics, religion.** To this could be added the particular expression of the **community.**’ (Frampton 1980)

Professor Roger Fisher in the article titled *The Third Vernacular: Pretoria Regionalism-Aspects of an Emergence*, concedes that the factors of the afore-mentioned quote as generators of form and style of the vernacular house, can be adopted to any building type which have a regionally specific character. According to Fisher (1998), the term ‘**vernacular**’ is awarded to a tradition of a particular architectural expression when it becomes endemic.

It is worthy to remain cognitive of the fact that cultures although relatively autonomous, employ a constant **gradual evolution**, influenced from time to time by other cultures. In this way cultures constantly renew and reorganize themselves in a similar manner to an autopoiesistic system. Frampton (1980) concedes that “*Culture is transient, not static, and since ancient times has been defined and influenced by other cultures.*’

Within the context of Africa, cultural evolution and inter-influenced is best described by the ‘**Triple Heritage Concept.**’ The Triple Heritage Concept is the illustration of the three prevalent or dominant socio-cultural influences in African culture, namely; Indigenous, Islamic, and Western, introduced by Professor Ali Mazrui and described in the book *African Architecture Evolution and tradition* by Namdhi Elleh (1997).

The cultures in the regional context of South Africa have largely been influenced by Indigenous and western principles. South African society’s perceptions and values are governed by two cultural spheres respectively; namely the **African** and the **European**.

Let us briefly summarise the two influential principles namely, indigenous and western, respectively.

## INDIGENOUS INFLUENCE-UBUNTU

## PHILOSOPHY

The South African cultures can be broken down into various clans and their traditions, but central to all, is the philosophy of *Ubuntu*. The spirit of **humanness, respect, hospitality, order and of community** is embraced by all indigenous clans in African culture. This spirit has been constant throughout the chronology of development of African cultures. In this context African culture represents the core principle of any African tradition that is: *Ubuntu*.

*Ubuntu* embraces the notion of **interdependence** between people, and further extends this interdependence to the relation between people and their environment, whole-ness. In the realm of *Ubuntu*, Ramosi [1999] concedes that “*Humanness regards the being or the universe as a complex wholeness involving the multi-layered and incessant interaction of all entities.*”

The maxim *umuntu ngumuntu ngabantu* (Ramosi 1999), loosely translated meaning: ‘*no man is an island,*’ is evidence to the interrelation and interdependence between people. The whole-ness outlook to existence encompassed in the philosophy of *Ubuntu*, underpins the interdependence between human beings and physical nature. It becomes justifiable to suggest that the concept of *Ubuntu* exhibits characteristics of **ecosystemic** and **autopoiesistic** thought.

The following statement by SITE architects [1980] unwittingly makes reference to the notion of *Ubuntu* “*...if architecture is to regain its status as a meaningful public art, it should be questioned in most of its prevailing definitions in order to become more responsive to the diversity, complexity, and subconscious motivations of our pluralist society.*”

The fundamentals of *Ubuntu*, when appropriately translated into architecture, have the potential of promoting the realisation of a **regional architecture**.



Figure 2.2.7 Pedi village isometric (Architecture SA May/June 2006:43)

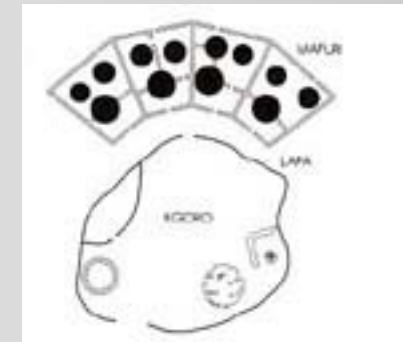

Figure 2.2.8 Pedi village plan (Architecture SA May/June 2006:43)

PLANNING PRINCIPLES

Traditional vernacular settlements of South Africa are characterised by a similar planning layout. This layout which is synonymous with **Bantu** homesteads consists mainly of the following spaces: huts, cattle kraal, granaries of a man and his family, family dependants and followers. (Denyer 1978).

The typical homestead layout follows a circular form. The entire homestead is usually fenced-in for security and accessible from one point. The point of access is located directly opposite to the man's hut 'great hut.' Between the great hut and access point lies the centrally-placed cattle kraal. The development or addition of more huts for additional wives or children occurs in a semi-circular arrangement flanking the great hut on either sides. The cattle kraal is seen as the core **communal centre** of each homestead, and its centrality is defined by the arrangement of huts around it.

These homesteads are security conscious through the employment of one entrance, and locating the cattle kraal (family wealth) centrally, where it can be easily watched by all members of the family. This system operates along similar lines as the idea of **common land** as defined by Christopher Alexander in the book *A Pattern Language*. The architectural quality of these otherwise austere structures was enhanced through decorative finishes of various **textures, patterns and colours**.

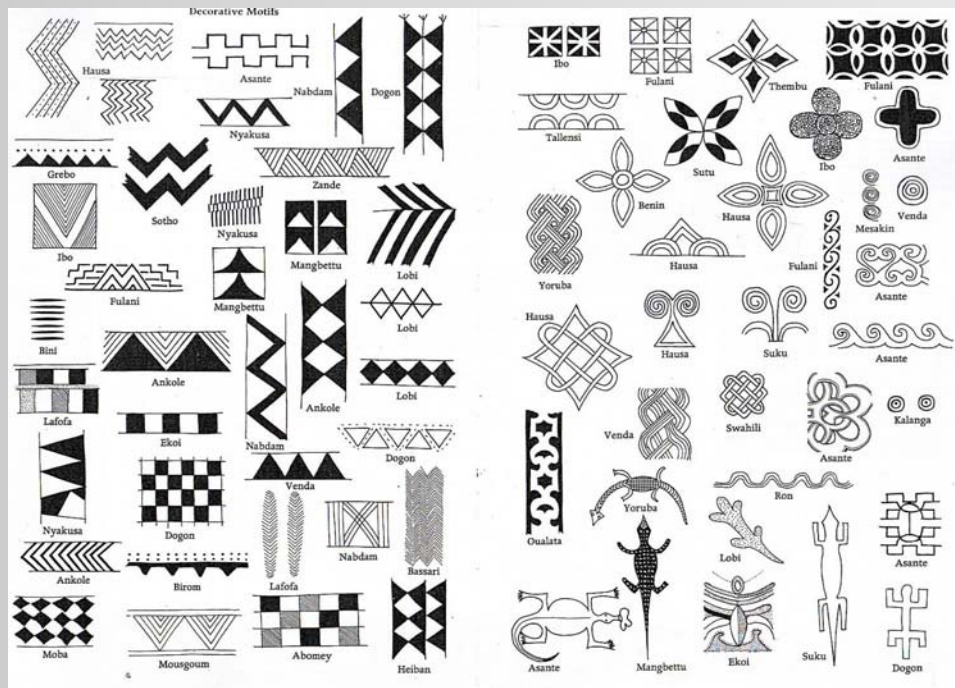

Figure 2.2.9 Decorative motifs (Denyer 1978:121)

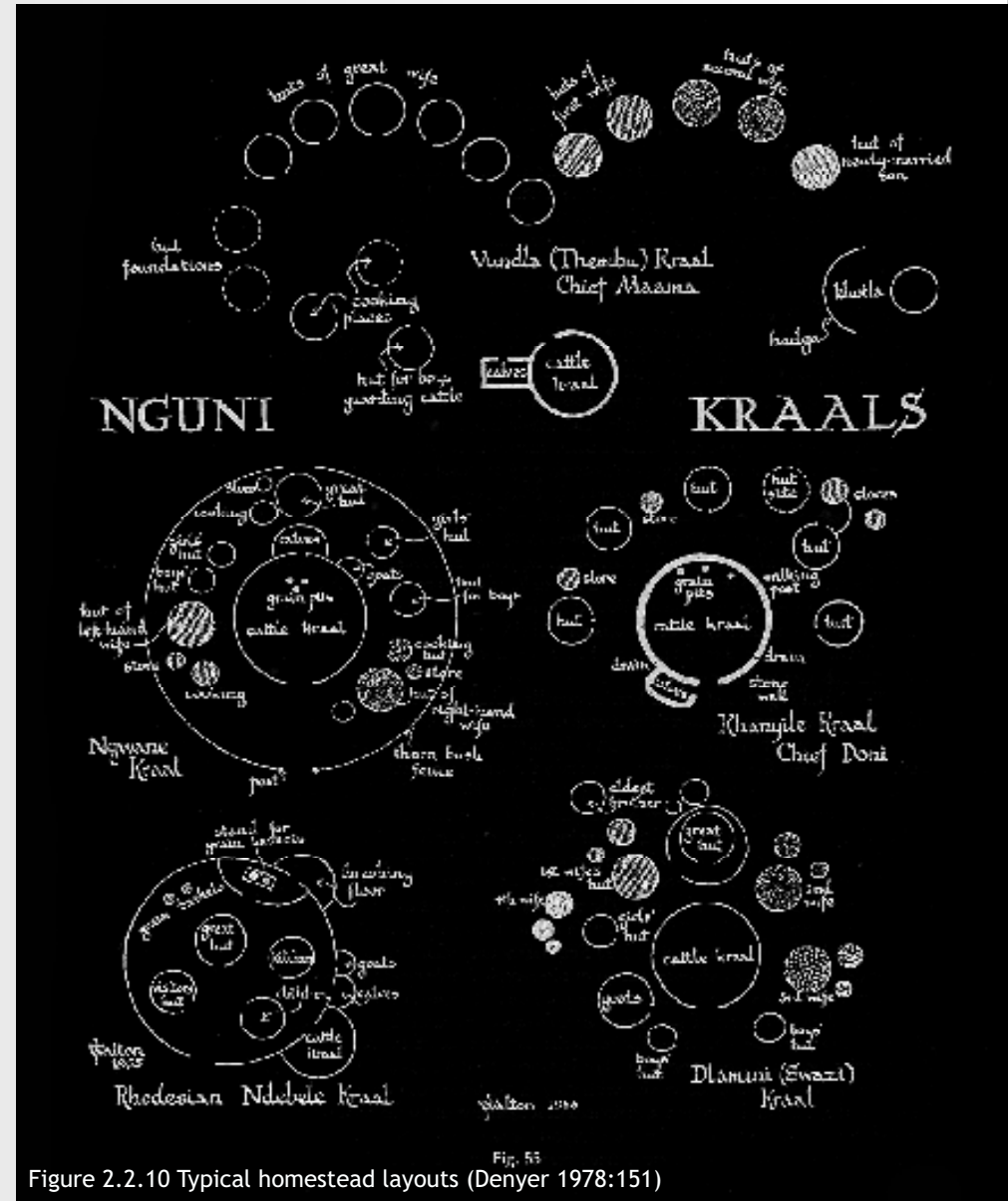

Figure 2.2.10 Typical homestead layouts (Denyer 1978:151)





Figure 2.2.11 Typical Zulu village layout (Denyer 1978:113)

WESTERN INFLUENCE-URBAN PLANNING THEORY

Generally, urban planning philosophy is outlined by four key principles, namely : Systemic, Functionalist, Humanist, and Formalist.

*Systemic*

Manifests a cognitive understanding of social systems at play, and recognizes the existing patterns as cues for further development.

*Functionalist*

Concerned with the establishment of the city core and furthermore, civic interaction within such a core. Advocates the preservation of historically significant fabric for educational purposes.

*Humanist*

Endeavours to prioritise the social domain within architecture, promotes the process of development that is dictated by the user's needs. The humanist use the past as a point of reference, and not replication.

*Formalist*

Promotion and understanding of the timeless qualities of culture and urban heritage. Principles based upon axial planning to achieve order and hierarchy.

CONCLUSION

Through the medium of architecture, principles of urban planning theory shall be balanced with the fundamentals of *Ubuntu* in order to arrive at an eco-systemic, and sustainable end product. People relate better to elements that they can identify with, hence in South Africa, where we have citizens of both African and European origin, it is crucial to strike a balance between the cultural inclinations of both spheres. In many regards there exists parallels between the philosophy of *Ubuntu* and the urban planning principles, which makes it easier to infuse elements of the one into the other and vice-versa.

Notably, vernacular architecture has not been used at a scale beyond the residential compound and village, however the principles of spatial hierachy and climatic understanding can be extended to large scale design such as a transport interchange. Since urban planning is mostly used large scale planning such as city layouts, it is here where the elements will be merged and the result will be both micro and macro factor analysis and understanding.

The architecture that is surfacing recently in South Africa seems to be primarily defined by colour and texture, maybe that could be an area of attention.

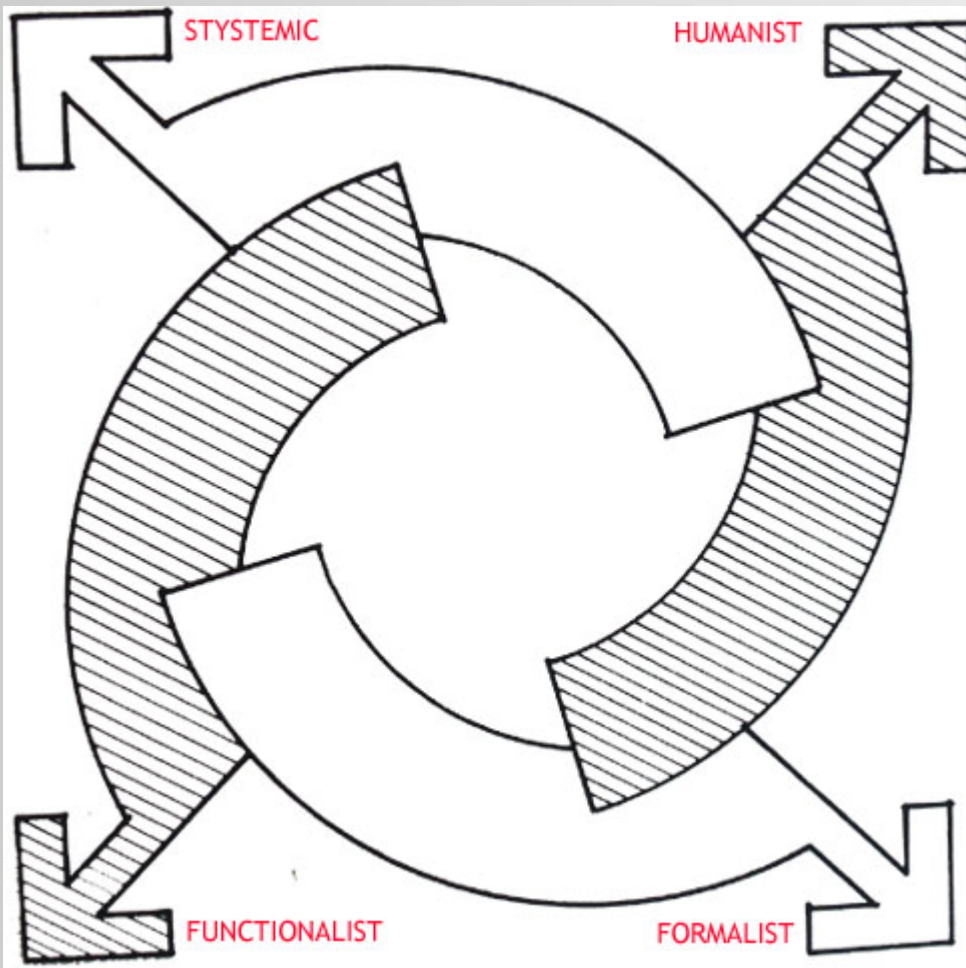

Figure 2.2.12 Urban planning diagram (Attoe and Logan 1989:17)

## RELEVANT PRECEDENTS

The analysis of precedent studies shall focus on a balance between international and local examples. Valuable lessons can be learnt from how the international community dealt with similar challenges, however local examples provide for better information by virtue of a closer and relevant contextual relation. The selected precedents attempt to explore the positive qualities of both intermodal transport interchanges and public spaces.

## INTERNATIONAL PRECEDENTS

**LUCERNE STATION**, Switzerland 1983-1989, *Santiago Calatrava*.

Lucerne station is a 109 x 14 x 19m altogether new virtually freestanding hall addition to an existing building by Calatrava. The original structure was built in 1896, and later modified in 1975. The design explores the limits of tension and compression, combined with the extensive use of glazed curtain walling and suspended roof. The result is a structure characterized by a colossal concrete cantilever roof, spanning the entire length of the building, furthermore gigantic 14m concrete columnar elements support the roof in an order that makes reference to the neo-classical character of the neighbouring buildings, in a modern way.

Although visible distinct from the original structure, Calatrava's intervention remains sensitive to scale, it is visible, but it does not supercede the existing building.

The selection of materials is undeniably modern: concrete, glass, steel, and the effect is a structure that permits sufficient light through the glazed curtain walling, and suspended glass roof, all tied together with meticulous details.

The structure is a visual marvel.

A few similarities exist between the Lucerne station and the Pretoria station. The Pretoria station is a modern addition in a precinct anchored in heritage value, thus the need for sensitivity towards the heritage fabric of the precinct exists. Lessons of appropriate scale can be drawn from the Lucerne station. The tectonic resolution of the glazed curtain walling provides ideas as to resolving similar situations at the Pretoria station. Lastly, the quality of light can be drawn upon, and the tact to create a seemingly light structure.



Figure 2.3.1 View of main facade (www.vitruvio.ch)



Figure 2.3.2 View of main facade (www.vitruvio.ch)



Figure 2.3.3 Roof detail (www.vitruvio.ch)



Figure 2.3.4 entrance (www.vitruvio.ch)

*NORTH GREENWICH TRANSPORT INTERCHANGE, JUBILEE LINE EXTENSION, UK 1998, Foster and Partners*

The interchange is located right next to Millenium Dome, and forms part of the regeneration of the Northern Greenwich peninsula. Positioned directly above the North Greenwich Underground station, the station is characterized by the 160m wide semi-circular roof which shelters arriving and departing passengers. The roof is divided into two by a centrally placed waiting room, the one end of the roof hosts the drop-off point for taxis and cars, the other end houses the bus arrivals and departures. Essentially, this development is a taxi and bus mode addition to an existing rail subway. The ground circulation follows the curved shape of the roof, and is simple and clearly defined. Technically, the roof canopy is perforated to allow daylight to illuminate the deepest spaces, while specially designed lighting units suspended from the ceiling can both project light up to the reflective aluminium ceiling panels and spotlight area immediately below (Phaidon 2004).

The exemplary aspects of this structure lies in the effortless planning and subtle separation of the bus area to the taxi area, and how the space in between conveniently houses the waiting rooms. Furthermore, the simplified vehicle circulation route.



Figure 2.3.5 Interchange aerial view (Phaidon 2004:300)

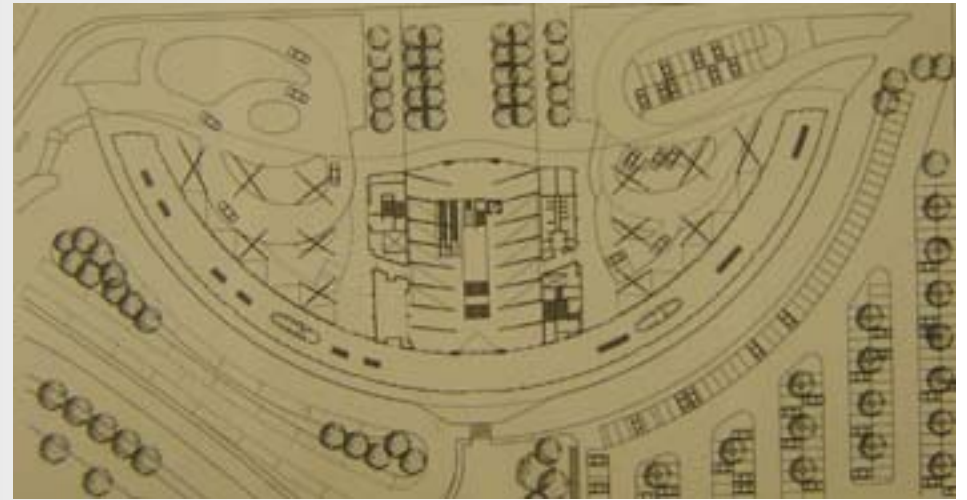

Figure 2.3.6 Plan (Phaidon 2004:300)

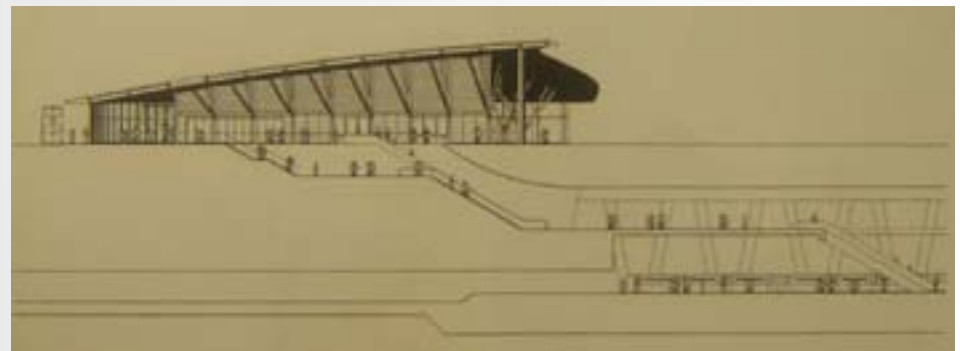

Figure 2.3.7 Section (Phaidon 2004:300)

**THE SOUTH AFRICAN EMBASSY, BERLIN**, Germany 2003, MMA Architects.

The Embassy is located in Tiergarten Park, an embassy district in Berlin, exactly where the original building had been bombed during WW2 (Architecture SA November/December 2004). The building is designed around a central 4 storey atrium with the activity spaces located around the periphery. The design teams philosophy was to conceive a building that would explore the identity of the new South Africa.

To achieve this quest, the selection of materials reflected South Africa's building tradition, namely: stone, plasterwork, metal, wood and wattle. The exterior skin of the structure is clad with honey-coloured sandstone quarried from Limpopo, and black granite used in the building is imported from Zimbabwe.

Although the layout is a rather modest rectilinear plan around a central atrium, the character of the building and 'identity' is manifested through the detailing. The interior is detailed in elements that are reminiscent of South African vernacular architecture, for example the balustrades have a grab rail that makes reference to Ndebele beadwork. A 14m high panel of plaster work, modelled on the traditional *litema* was crafted by local artist on site, and so was a panel of woven art hung in the atrium. The sculptures in the building were created by local artists. Located in the rear garden is a column also treated in a *litema*-like finish. (Architecture SA November/December 2004)

The exterior is characterized by bands of horizontal aluminium elements that conceal the cladding joints, and help reflect the sun.

The building provides an example of the simplicity and elegance of a rectilinear form around a central court, and how local materials can be used in a modest yet strikingly appealing manner. Lastly, the value, aesthetically and practically of showcasing the work of local artists and how such a gesture could grow to be synonymous with local architecture.

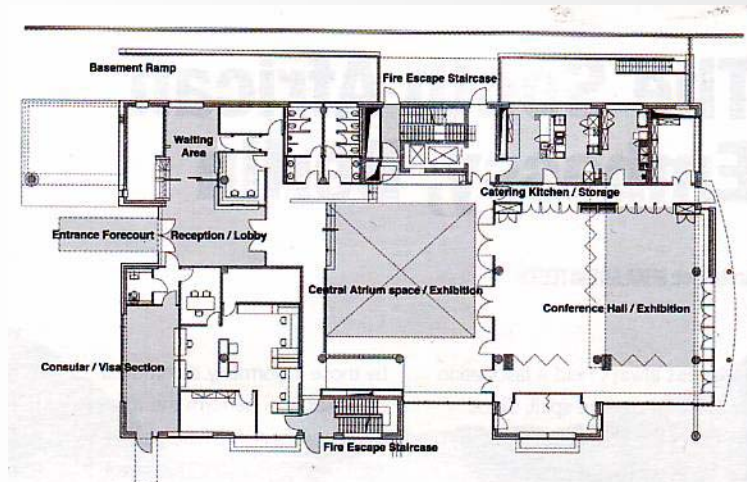

Figure 2.3.8 Ground plan (Architecture SA November/December 2004)



Figure 2.3.9 Building detail.  
(Architecture SA November/December 2004)

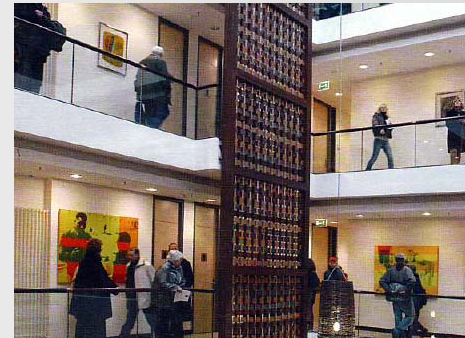

Figure 2.3.10 Atrium.  
(Architecture SA November/December 2004)



Figure 2.3.11 *Litema* plaster panel.  
(Architecture SA November/December 2004)



Figure 2.3.12 Rear garden.  
(Architecture SA November/December 2004)

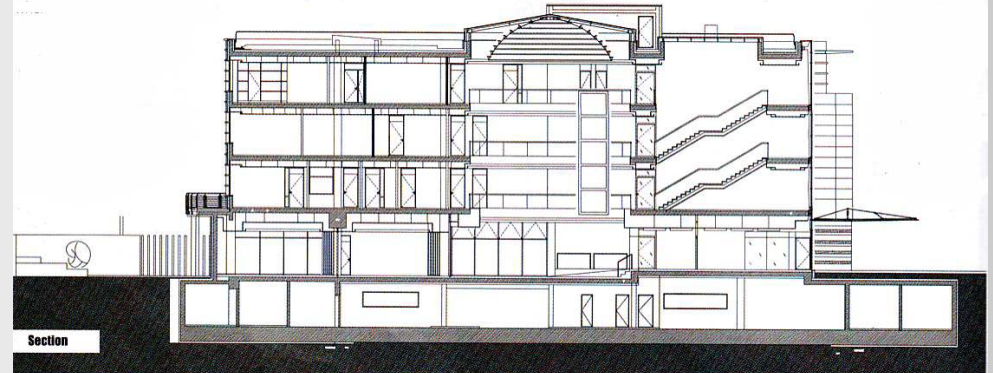

Figure 2.3.13 Section.  
(Architecture SA November/December 2004)

**FEDERATION SQUARE, Australia 1997, Lab Architects and Bates Smart Architects.**

The development of Federation Square essentially began in the mid 1990s as part of the Jolimont Rail Yard rationalisation project that reduced the railway lines running parallel to the Yarra River from a total of 53 lines to 12, an initiative made possible by improved railway technologies and the relocation of space consuming shunting operations to more outer-lying locations in Melbourne. ([www.federationsquare.com](http://www.federationsquare.com))

During the project, the Victorian state government in association with the Melbourne city council initiated an international design competition to design a square over the existing rail lines, and remove two eyesore buildings, namely the 'Gas' and 'Fuel' towers.

Lab architects design philosophy was to make the square the new centre of cultural activity for Melbourne, under the theme: 'Independent identities combining for a larger whole.' ([www.federationsquare.com](http://www.federationsquare.com))

The development is bordered on one end by the Yarra river, adjacent to that side lies the Princes bridge. the layout is anchored around an irregular shaped 20 000 people capacity public square bordered by a series of buildings, almost all of which open up directly to the square. The surrounding buildings are multi-use in function, ranging from a national art gallery, covered public spaces, indoor auditoriums, offices, cinema complex, a cathedral, and about 15 restaurants, cafe's and bars.

Federation Square is Melbourne's meeting place and a unique cultural precinct. ([www.federationsquare.com](http://www.federationsquare.com))

Distinct similarities can be drawn between Federation square and The Pretoria station. Both these areas have a history attached to the rail development of their respective cities. The development of Federation square was succesful attempt of regenerating an area with the emphasis on civic activity and upliftment, in a similar way that the Pretoria Station interchange attempts. Again, federation square, similarly to the Station interchange anchors around a multi-use public square, with multi-function buildings anchored around it.

Federation square sets the precedent on how to create a civic environment that the users can relate to.



Figure 2.3.14 Night panorama. ([www.federationsquare.com](http://www.federationsquare.com))

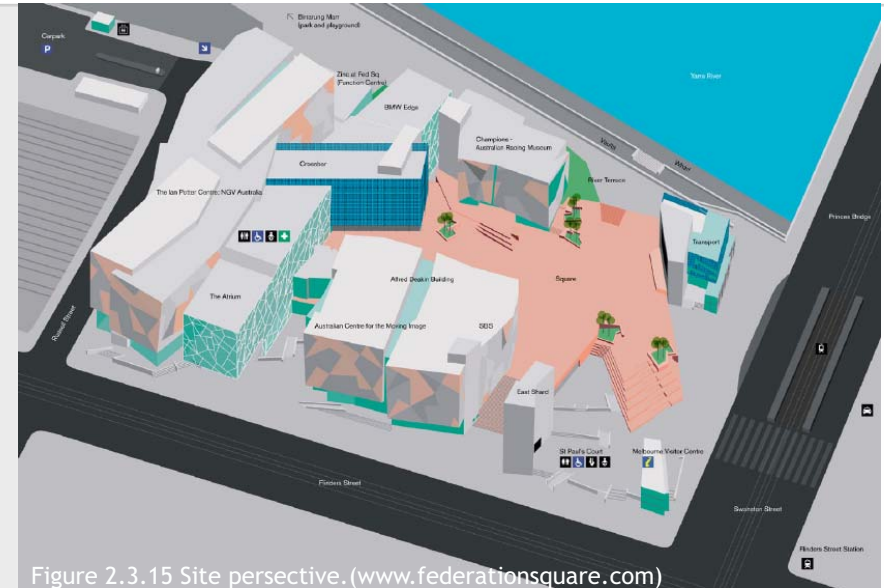

Figure 2.3.15 Site perspective. ([www.federationsquare.com](http://www.federationsquare.com))



Figure 2.3.16 Live events. ([www.federationsquare.com](http://www.federationsquare.com))



Figure 2.3.17 Restaurants. ([www.federationsquare.com](http://www.federationsquare.com))



Figure 2.3.18 Site panorama. ([www.federationsquare.com](http://www.federationsquare.com))

## LOCAL PRECEDENTS

**METRO MALL**, Johannesburg 2003, *Urban Solutions*.

The Metro Mall is a mixed-use intermodal development incorporating buses, taxis, retail, offices, restaurants, and informal trade. The development is located in the hub of one of Johannesburg's prime regeneration areas: Newtown.

Metro mall accommodates 25 buses, 2000 mini-bus taxis, 800 merchants, and is used by over 100 000 people daily.

Essentially the development is two similar buildings on separate adjacent blocks handled in a similar fashion. The one structure serves Lenasia taxis, and the other, Soweto taxis. The taxi loading zones act as high volume centralized courtyards, bordered by shops, and hawker stalls located on the periphery.

The planning is based around public and private streets. The building front faces Bree street which is an extremely busy one way street. Most of the buildings retail areas are placed along this front, and restricted entirely to pedestrian activity. A buffer zone of hawkers exists between the street edge and the taxi loading zones inside the structure. Parallel to Bree street is Gwengi Mrwebi street, the more private and quieter street that is used for the taxi and bus entrances and exits. This is viewed as the back of the building, where pedestrian movement is discouraged.

The ground floor of this development is designed to be the main public/pedestrian level, with the shops, restaurants, and hawker space placed on the level, including the taxi loading zones. The Basement houses the buses. The levels above the ground floor are more private, with the driver recreational facilities, storage for hawkers, management offices, and taxi parking.

The building remains contextually and functionally appropriate through the use of commonly available yet robust materials. The facades are characterized by red brick (common in Johannesburg), and concrete. The use of concrete and brick provides for a robust feel. The entrances are accentuated by the addition of tall towers, decorated by a local artist's steel work, to orientate and celebrate entry. More sculptural elements are littered throughout the structure, done by local artists. The planning is functional and quite legible.

Similarly to Station Interchange, Metro mall is situated right in the city. The mall is a good local example of how to deal with high traffic volumes in a practical manner, and how robust materials can be used to have aesthetic appeal. Lessons on how to plan around the public private relation using various levels are valuable, furthermore, how the entrances are defined is exemplary.



Figure 2.3.18 Facade treatment.



Figure 2.3.20 Entrance treatment

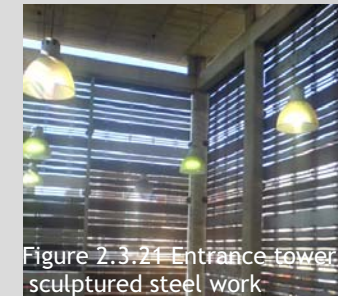

Figure 2.3.21 Entrance tower sculptured steel work



Figure 2.3.22 Plans. (Urban Solutions)

**UNIVERSITY OF PRETORIA LAW FACULTY BUILDING**, Tshwane 2004, Kruger Roos Partnership.

The layout is a simple rectilinear structure oriented predominantly in an east-west axis. This simple rectilinear structure contains 'green pockets' in the form of two uncovered tree-lined courtyards, around which lecture facilities are arranged. The courtyards feed off from the main walkway that spans the length of the building. The entrance is defined by a visual continuation of an existing avenue of trees, and is accessible from both the north and south.

The planning is such that major public traffic is restricted to the ground floor, where the lecture venues, library and auditorium. The upper levels are dedicated to more private areas like the study areas and offices.

The techtonical approach to the building sees the south facade completed in glazed curtain wall, that invokes a sense of transparency. The glazing is recessed to reduce the amount of heat load on the surface. The south facade transmits light into the interior, gives a feel of lightness to the structure. The north facade comprises of a solid wall punctured by various sized windows, in a strip or vertical orientation.

The design takes advantage of passive means of climate control, through the entire-building-length-spanning main walkway (gallery) that is outside but covered on all four levels.

The handling of uncovered courtyards and their relation to the adjacent covered spaces provides positive lessons. The building is designed to around a simple, rational, and highly legible circulation pattern. Another fine example is how the public activity is limited to the ground and first floors, while the upper floors are dedicated to more private activities. (Architecture SA November/December 2004)



Figure 2.3.23 Ground Plan. (Architecture SA November/December 2004)



Figure 2.3.24 South east view. (Architecture SA November/December 2004)

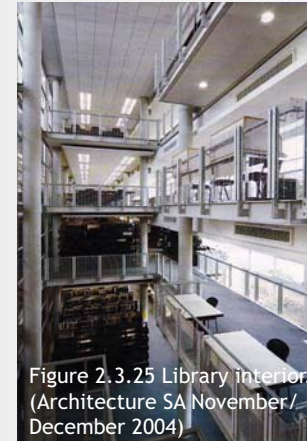

Figure 2.3.25 Library interior. (Architecture SA November/December 2004)



Figure 2.3.26 Facade detail (Architecture SA November/December 2004)



Figure 2.3.27 North east view. (Architecture SA November/December 2004)



**MARY FITZGERALD SQUARE**, Johannesburg 2000, GAPP Architects and Urban designers

The square is located right in the hub of Johannesburg's cultural precinct of Newtown. Originally the square was a wagon site called Aaron's ground and later renamed Mary Fitzgerald in 1939 to honour the first woman trade unionist who played a key role in the 1910 miner's strike. ([www.joburg.org.za](http://www.joburg.org.za))

The square takes up an entire block, but is divided in half by a generous walkway running across the entire width. With a capacity of 50 000 people, coupled with the gigantic 55m<sup>2</sup> LED screen, the square has become a popular venue for public gatherings. Film festivals, markets, concerts and important live broadcasts are just some of the events that the square hosts. However, on a daily basis the square is used as parking space.

Two sky disks are major elements on the square. The first depicts the stellar constellation as at the birth of Mary Fitzgerald, the second depicts the constellation as at the first democratic election of 27 April 1994. There is a third, which can be found at the entrance to the Museum Africa depicting the constellation as at the official launch of the square on 16 December 2001 - Reconciliation Day. The disks use unique optic fibre lights that glow in the dark. ([www.joburg.org.za](http://www.joburg.org.za)).

Tectonically, the square is paved with concrete interlocking pavers for a durable and robust effect, and to assist stormwater run-off. The boundary is demarcated all-round with concrete street furniture. The northern and eastern ends of the square have wooden carved sculptures mounted on concrete bases, done by local artists. In addition, Renowned French lighting engineer, Patrick Rimoux was commissioned to design the lighting for this square as well as for the surrounding public open spaces. ([www.joburg.org.za](http://www.joburg.org.za))

Public drinking fountains are provided, also detailed in concrete.

The square is modern, robust, and functional. Lessons can be learnt from the simple, yet functional design, and how to incorporate the work of local artist in creating visually appealing boundary demarcators.



Figure 2.3.29 Generous walkway.



Figure 2.3.31 Drinking fountain.



Figure 2.3.30 Lights.



Figure 2.3.32 Wooden carved sculptures.



Figure 2.3.28 Square panorama looking west

## *CHAPTER 3*

Page 45-63

## INTRODUCTION TO SUSTAINABILITY

Carbon dioxide emission in the atmosphere remains the largest greenhouse gas contributor to the issue of global warming. (The Digest of South African Architecture 2001/2002 Volume 6:160).

The construction industry is the world's largest industrial employer with 111 million employees and approximately 28% of all industrial employment, furthermore the built environment consumes between 40 and 50% of all energy generated in the world. (Gibberd 2003). Buildings on their own could responsible for up to 40% of global warming. (Architect and Specificator January/February 2005:35). The magnitude of construction activity is fast depleting the world of its non-renewable resources.

Considering the impact that the built environment has socially, economically, and environmentally, it becomes crucial that architects all over the world need to conceive design solutions that mitigate the effect of greenhouse gases, thus yielding a sustainable architecture.

## WHAT IS SUSTAINABILITY?

According to the Oxford English mini-dictionary the word '*sustainability*' means: avoiding using up natural resources.

The World Commission on Environment and Development describes sustainable development as development that "*meets the needs of present without compromising that ability of future generations to meet their own needs.*" (Yang,J; Brandon,PS; Sidwell, AC 2005:ix)

## SUSTAINABILITY AND ITS RELATION TO THE PRETORIA STATION INTERCHANGE

The development of the Pretoria Station Interchange needs to be both contextually and environmentally appropriate. The combined effects of global warming and the ever looming resource depletion situation means that every new development should be carefully considered according to the principles of the 'Triple bottom line' of social, economic, and environmental aspects.

This chapter analyses sustainable developments and their impact on the planning of buildings. Commonly used international building sustainability assessment tools are briefly introduced, but emphasis is placed on the locally developed assessment tool, namely, SBAT (Sustainable Building Assessment Tool). Towards the end of the chapter, the Pretoria station interchange is analysed according to the SBAT and the results are plotted on a results chart.

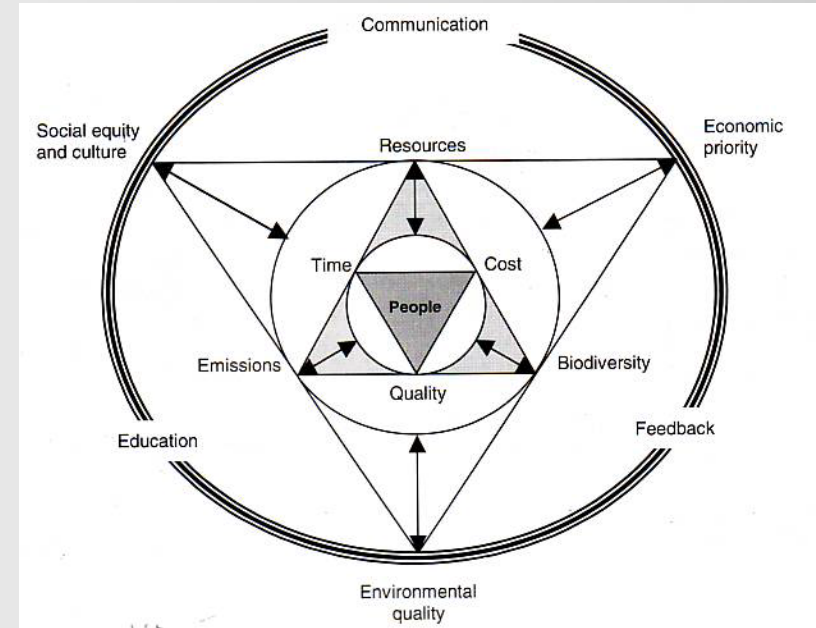

Figure 3.1.1 Intergrated approach to sustainable built environment (Yang, Brandon, and Sidwell 2005:xiii)

## SUSTAINABLE ARCHITECTURE

In the context of architecture, sustainability can be broadly defined as: the conscious design of buildings in a manner that employs the most minimal disturbance to the ecological balance of a site, avoids the use non-renewable resources, contextually appropriate with regards to climate, and requires low maintenance over its lifecycle.

**'The creation and responsible maintenance of a healthy built environment based on resource efficient and ecological principles.'** (Yang,J; Brandon,PS; Sidwell, AC 2005:ix)

5 keys principles guide the path towards sustainable architecture, (The Digest of South African Architecture 2001/2002 Volume 6:160) namely:

- Analyzing the site conditions
- Energy consumption
- Indoor environment components
- Waste management
- Reduce water consumption

## ANALYZING THE SITE CONDITIONS

Climate informed orientation of the building on the site based on optimum light and ventilation exposure helps drastically reduce the building's reliance on mechanical cooling and electrical energy. A well designed building site allows natural energy sources to work for the architect. (The Digest of South African Architecture 2001/2002 Volume 6:161).

## ENERGY CONSUMPTION

The amount of energy consumed by the built environment accounts for between 40 and 50% of the entire world's energy consumption. Products such as energy-efficient fluorescent bulbs have the potential to reduce the energy impact and life-cycle maintenance of a building, similarly, water-efficient products are also available, all aimed at improving the energy consumption of the building. Substantial cost capital savings for heating, ventilation, and air-conditioning can be achieved by controlling the heat gain or loss from windows and heat produced by lights and office equipment. (The Digest of South African Architecture 2001/2002 Volume 6:161). The careful selection of materials and understanding of the energy properties thereof curbs the situation of wasteful consumption.

## INDOOR ENVIRONMENT COMPONENTS

The comfort of the interior spaces in any structure is of paramount importance, an error in such regard results in sick building syndrome and indoor pollution. Needless to say, sick building syndrome and indoor pollution leads to reduced staff productivity and efficiency, and in severe cases, even litigation. The choice of materials largely regulate indoor comfort, therefore it is important that the materials do not have a negative effect on the interior space.

## WASTE MANAGEMENT

Buildings alone currently contribute about 600 million tonnes of air pollution each year. (The Digest of South African Architecture 2001/2002 Volume 6:161). The design of buildings should anticipate the possible future trends during that particular life-cycle, in such a manner that the material should be easily recyclable and reusable. Building materials such as glass steel, and timber are examples of materials that are fully recyclable. In the event of demolition the building should leave a minimal ecological impact on the environment.

## REDUCE WATER CONSUMPTION

It is advantageous to reduce water consumption within the building and on the building site. Within the building, products that are water efficient more especially for ablutions, are being developed. On the building site, it is advised to use landscaping that does not require huge amounts of water, and also to harvest rainwater to supplement irrigation systems.

## SUSTAINABLE COMMUNITIES

Sustainable communities are those that balance the Earth's physical resources with the social, economic, and environmental needs of its society. (Yang, J; Brandon, PS; Sidwell, AC 2005:ix)

Agenda 21 provides the following description:

**'Humanity stands at a defining moment in history. We are confronted with a perpetuation of disparities between and within nations, a worsening of poverty, hunger, ill health, and illiteracy and the continuing deterioration of the ecosystems on which we depend for our well-being.**

**However, intergration of environment and development concerns and greater attention to them will lead to the fulfillment of basic needs, improved living standards for all, better protected and managed ecosystems and a safer, more prosperous future. No nation can achieve this on its own, but together we can in global partnership for sustainable development.'** (Steele 1997:9)

Sustainable communities are those that strive to abide by the afore-mentioned principles, that is to be resource efficient by not depleting the earth of its natural resources. Coupled with being environmentally friendly, sustainable communities need to be both socially and economically viable. The community well-being largely determined by its environmental, social and economic sustainability.

## SOCIAL SUSTAINABILITY

Improvement of the quality of life and human rights through the creation of a safe, healthy, and secure environment.

Improvement of the quality of life and human rights through the creation of a safe, healthy, and secure environment.

Educating the community on issues affecting sustainability.

User friendliness through easy and convenient access by foot, car or wheelchair.

Encouragement of public participation through active interaction with the affected people.

ECONOMIC SUSTAINABILITY

- Creation of low skill labour intensive jobs during construction period.
- Economic upliftment through the provision for SMME, and informal trade accommodation.
- Commissioning of local artist and sculptors.
- Income generation through incorporation of tourist activities.
- Reduced running and maintenance costs by virtue of passive design systems considerations.
- Ensuring that development is based on a scientific approach which measures and monitors social, environmental and economic impacts and this is used to guide development.

ENVIRONMENTAL SUSTAINABILITY

- Reduced wastage of natural resources and emission of greenhouse gases.
- Minimal interference with the existing ecosystem.
- Minimal use of materials with a high embodied energy.
- Efficient consumption of water, and harvestation of stormwater to supplement irrigation and other non 'health hazard' water uses.
- Minimal use of non renewable resources and the reduced energy consumption through passive climate control systems.
- Explore the potentials of reusing existing buildings on the brownfield site.

TABLE 1 Images of architectural sustainability

Image	Dominant concerns	Dominant horizon	Symbolism/aesthetics	Approach
Natural	Environmental place, ecosystems, health, balance	Local	'Touching the earth lightly' with forms echoing nature	Study local natural systems; emphasize sensitivity and humility in relation to nature.
Cultural	Cultural place, people, <i>genius loci</i> , difference, cultural sustainability	Local	Highly contextual with forms, materials and construction methods echoing the local vernacular	Study local culture and building; emphasize local involvement and local expertise
Technical	Technologies, global environmental impacts, cost-benefit analysis, risk management	Global	Leading edge contemporary international systems	Study science, economics and technology; emphasize transnational expertise

(Williamson, Bradford, and Bennetts 2003:25)

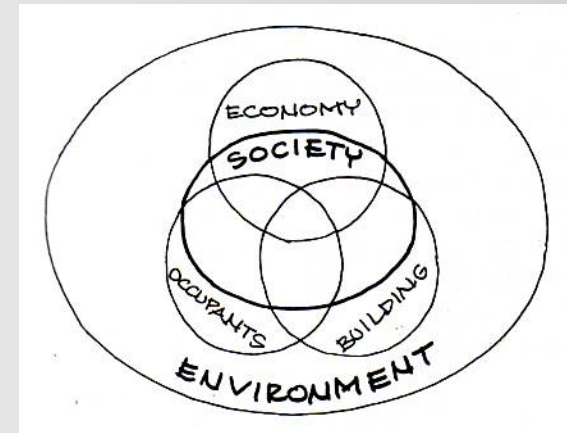

Figure 3.1.2 3 Systems diagram (Williamson, Bradford, and Bennetts 2003:85)

## INTERNATIONAL CONVENTION TO MEASURE SUSTAINABILITY

The international community's response to building energy concerns has been the development of various conventionally used tools that measure the sustainable performance of buildings. The United Kingdom, Europe, and the United States have been in the forefront in developing sustainability tools such as the following: BREEAM, LEED, AND GBtool.

## BREEAM

The Building Research Establishment Environmental rating Method (BREEAM) was developed in 1990 by the Building Research Establishment (BRE), a UK institution. Though initially developed for use on commercial buildings, it has become a benchmark for all building types to minimise any negative environmental impact. Versions of the BREEAM are currently being developed for Hong Kong and Canada.

The key aims of sustainable development described by the tool are the following:

- Social progress which meets the needs of everyone.
- Effective protection of the environment.
- Prudent use of resources.
- Maintenance of high and stable levels of growth and employment.

## TOOL AIMS

BREEAM aims to provide guidance on how to minimise the negative environmental impacts of buildings while ensuring that these provide comfortable and healthy indoor environments. (Gibberd 2003:96)

To distinguish buildings of reduced environmental impact in the market place.  
To encourage best environmental practice in building design, operation, management and maintenance.

To set criteria and standards going beyond those required by laws and regulations  
To raise the awareness of owners, occupants, designers and operators of buildings with reduced impact on the environment.

## ASSESSMENT APECTS

- Management
- Health & Comfort
- Energy
- Transport
- Water
- Materials
- Land use

Site ecology  
Pollution

## LEED

The Leadership In Energy and Environmental Design (LEED), Green Building Rating System was developed by the US Green Building Council. Its mandate was to provide a standard medium that rates buildings in the United States in terms of sustainability issues.

## TOOL AIMS

To provide a standard that improves the environmental and economic performance of commercial buildings using established or advanced industry principles, practices, materials and standards.

To be used by commercial building project stakeholders and project teams as a guide for green and sustainable design.

## ASSESSMENT APECTS

Sustainable Sites  
Water Efficiency  
Energy and Atmosphere  
Materials and Resources  
Indoor Environmental Quality

## GBtool

The GBTool has been developed to assess the environmental performance of buildings. The tool is part of the Green Buildings Challenge Assessment Framework, which is being developed by an international committee called the International Framework Committee. (Gibberd 2003:100)

The key aims of sustainable development described by the tool are the following:

To advance the state of the art in building environmental performance assessment methodologies.

To maintain a watching brief on sustainability issues to ascertain their relevance to "green" building in general, and to the content and structuring of building environmental assessment methods in particular.

Sponsor conferences that promote exchange between the building environmental research communities and building practitioners and showcase the performance assessment of environmentally progressive buildings.

To develop an internationally accepted generic framework that can be used to compare existing building environmental assessment methods and used by others to produce regionally based industry systems.

To expand the scope of the GBC Assessment Framework from green buildings to include environmental sustainability issues and to facilitate international comparisons of the environmental performance of buildings.

## THE SOUTH AFRICAN CONTEXT

### SBAT

The Sustainable Building Assessment Tool (SBAT) was developed in 1999 by the Council for Scientific and Industrial Research (CSIR). The CSIR is South Africa's leading research institute. ([www.joburg.org.za](http://www.joburg.org.za)). Initially developed as school pilot project, the tool has since evolved and been adopted to a broad range of building types such as leisure, education, residential and commercial. It is specifically aimed at implementation in developing countries. (Gibberd 2003:135)

The key uses of the SBAT are the following:

Part of a brief to the design team: by building owners and developers planning new buildings or refurbishments.

A decision support tool for: building design teams including Architects, Quantity Surveyors, Structural Engineers and Mechanical and Electrical Engineers

A way of ensuring that policies on sustainability are implemented and integrated into the construction environment: by government and other organisations. (Gibberd 2003:135)

### USING THE SBAT

Briefing  
Design and Outline assessment  
Detailed Assessment

### BRIEFING

The tool is useful in setting the targets that become the benchmark for the sustainability levels of the design.

### DESIGN AND OUTLINE ASSESSMENT

The SBAT can be used to support decision-making during the design process in the following ways. Once the criteria have been read and understood the design team can develop sketch designs and an outline material/component specification. Where there are choices in design or choices of material, the relevant criteria can be referred to in order to come to a decision. As soon as there is a full sketch design and outline material/component specification, an outline assessment can take place. (Gibberd 2003:138).

### DETAILED ASSESSMENT

The detailed assessment provides a more accurate measure of the building's sustainability performance. This section models the anticipated impact that the building is likely to have during its life-cycle.

### BUILDING LIFE-CYCLE

The life of buildings can be broken down into a number of discrete stages. These are as follows:

**Briefing:** This stage starts with the decision to develop a building and includes initial conceptualisation of the requirements of the building

**Design:** This stage include the development of the design of the building through to tender documentation

**Construction:** This stage refers to the construction of the building and ends at handover to owner or users on completion

**Operation:** This describes the stage where the building is in normal use and ends when a decision is made to refurbish or demolish the building

**Refurbishment/demolition:** This describes the stage when the building is deconstructed, or refurbished for further use. (Gibberd 2003:120)

### BUILDING ELEMENTS

A complete building is a composition of the following elements:

**Location:** This describes the location of the building.

**Site:** This describes the site and landscaping in which the building is located.

Size and shape: This describes the size and shape of the building.

Building envelope: This describes the physical envelope enclosing the building.

Internal space: This describes the space enclosed by the building envelope.

Furniture and fittings: This describes equipment, furniture and fittings located within the internal space.

Services: This describes services in the building such as water, electricity and telephone.

Materials and components: This describes the materials and components used in the building.

### TRIPLE-BOTTOM LINE CONSIDERATIONS

#### ENVIRONMENTAL SUSTAINABILITY

Damage to existing ecosystems must be halted and where possible, damage should be repaired and new ecosystems developed to replace the ones that have been lost. By retaining and developing productive ecosystems it may be possible, over time, to be able to increase the earth's carrying capacity and thus make it easier to balance this with human activities. Bio physical environments that support sustainability will include thriving, productive, resilient and adequately sized ecosystems that are well able to provide life support functions for man.

#### ECONOMIC SUSTAINABILITY

Economic systems have to be developed which enable societies to live within the carrying capacity of the earth. This will mean doing more with less. Economic systems will need to be more equitable, more resource efficient and value people and the environment.

#### SOCIAL SUSTAINABILITY

Societies will need to be more trusting, cooperative and share more. This will avoid wasting scarce resources on crime and defence. They will also need to become increasingly innovative and resourceful - in order to be able to maximise the benefit of limited resources for as many people as possible. Society will require organisation and capacity that enables, and ensures, that it's current and future members' needs are met and are able to live fulfilling lives within the carrying capacity of the environment. (Gibberd 2003:141).

## SOCIAL CONSIDERATIONS

### OCCUPANT COMFORT

The quality of environments in and around buildings have been shown to have a direct impact on health, happiness and productivity of people. Healthier, happier, more effective and people contribute to sustainability by being more efficient and therefore reducing resource consumption and waste. However the quality of this environment needs to be achieved with minimal cost to the environment. (Gibberd 2003:141)

#### Lighting

All work and living environments are well daylight. Day lighting control and glare minimised.

No spaces require constant electrical lighting.

#### Ventilation

Required ventilation provided by natural means. No mechanical ventilation used in building other than in toilets and kitchens.

#### Noise

Noise levels limited in work and living environments to acceptable levels.

#### Views

All living and work areas have access to a view out. All users located in 6m or less from a window.

#### Access to green outside

Access to green outside spaces

### INCLUSIVE ENVIRONMENTS

Buildings can be designed to accommodate everyone, or specially designed buildings need to be provided. Ensuring that buildings are inclusive supports sustainability as replication is avoided and change of use supported. (Gibberd 2003:141)

#### Public Transport

Building is located 100, or less metres to disabled accessible public transport.

#### Routes

All routes between and within buildings of a smooth and even surface (ie easily navigable by wheelchair).

#### Changes in level

No changes in level between or within buildings or,  
All changes in level catered for with appropriate ramps of 1:12 fall, or lifts.



**Edges**

All edges ie between walls and floors and stair nosings clearly distinguished through the use of contrasting colour (For visually impaired).

**Toilets**

Required number of disabled toilets provided.

**ACCESS TO FACILITIES**

Convention living and working patterns requires regular access to a range of services. Ensuring that these services can be accessed easily and in environmentally friendly ways supports sustainability by increasing efficiency and reducing environmental impact. (Gibberd 2003:142).

**Childcare**

Childcare provided in building or close by (within 3km).

**Banking**

Banking services (ie ATM) provided in building or close by (within 3km).

**Retail**

Grocery, items required on a day to day basis available in building or close by (within 3km).

**Communication**

Postal, telephone or email facilities provided in the building or close by (within 3km).

**Residential**

Home, for occupants of the building is within 12km.

**PARTICIPATION AND CONTROL**

Ensuring that users participate in decisions about their environment helps ensure that they care for and manage this properly. Control over aspects of their local environment enables personal satisfaction and comfort. Both of these support sustainability by promoting proper management of buildings and increasing productivity. (Gibberd 2003: 143).

**Environmental control**

Users of building have reasonable control over their environmental conditions, this should include opening windows and adjustable blinds.

**User adaptation**

Furniture and fittings ie tables, chairs, internal partitions designed or specified allow arrangement/rearrangement by user. Provision made for personalisation of spaces if desired. This may include provision for pin boards, choice of colours, places for plants and personal storage.

**Social spaces**

Design for easy informal / formal social interaction. This could involve a tea room with comfortable seating. Seating provided along regularly used routes. Spaces shared between occupants/users (ie photocopying rooms etc) large enough to allow for comfortable social interaction.

**Amenity**

Easy access to refreshment facilities (tea point, kitchen, vending machines) and WCs for all users of the building.

**Community involvement**

Spaces or services shared or made available to local community. This could include access to computers, teaching learning spaces, leisure facilities, crèche.

**EDUCATION, HEALTH AND SAFETY**

Buildings need to cater for the well being, development and safety of the people that use them. Awareness, and environments that promote health can help reduce the incidence of diseases such as AIDS. Safe environments and first aid can help limit the incidence of accidents and where these occur, reduce the effect. Learning and access to information is increasingly seen as a requirement of a competitive work force. All of these factors contribute to sustainability by helping ensure that people remain healthy and economically active, thus reducing the 'costs' (to society, the environment and the economy) of unemployment and ill health. (Gibberd 2003:143).

**Education**

Access to support for learning provided. This can be in the form of Internet access, structured courses, or the provision of learning material such as books, journals and newspapers.

**Security**

Measures taken to ensure that areas of the buildings and routes to and from the building are safe, and feel safe. Measures taken could include well lit routes, routes and spaces overlooked by occupied areas, clear visual links between spaces too.

**Health**

First aid kit provided in a central location. Policy to ensure that this can be used effectively. Information readily available on health, education, and career development issues. This could be in the form of well serviced notice boards located in a central position.

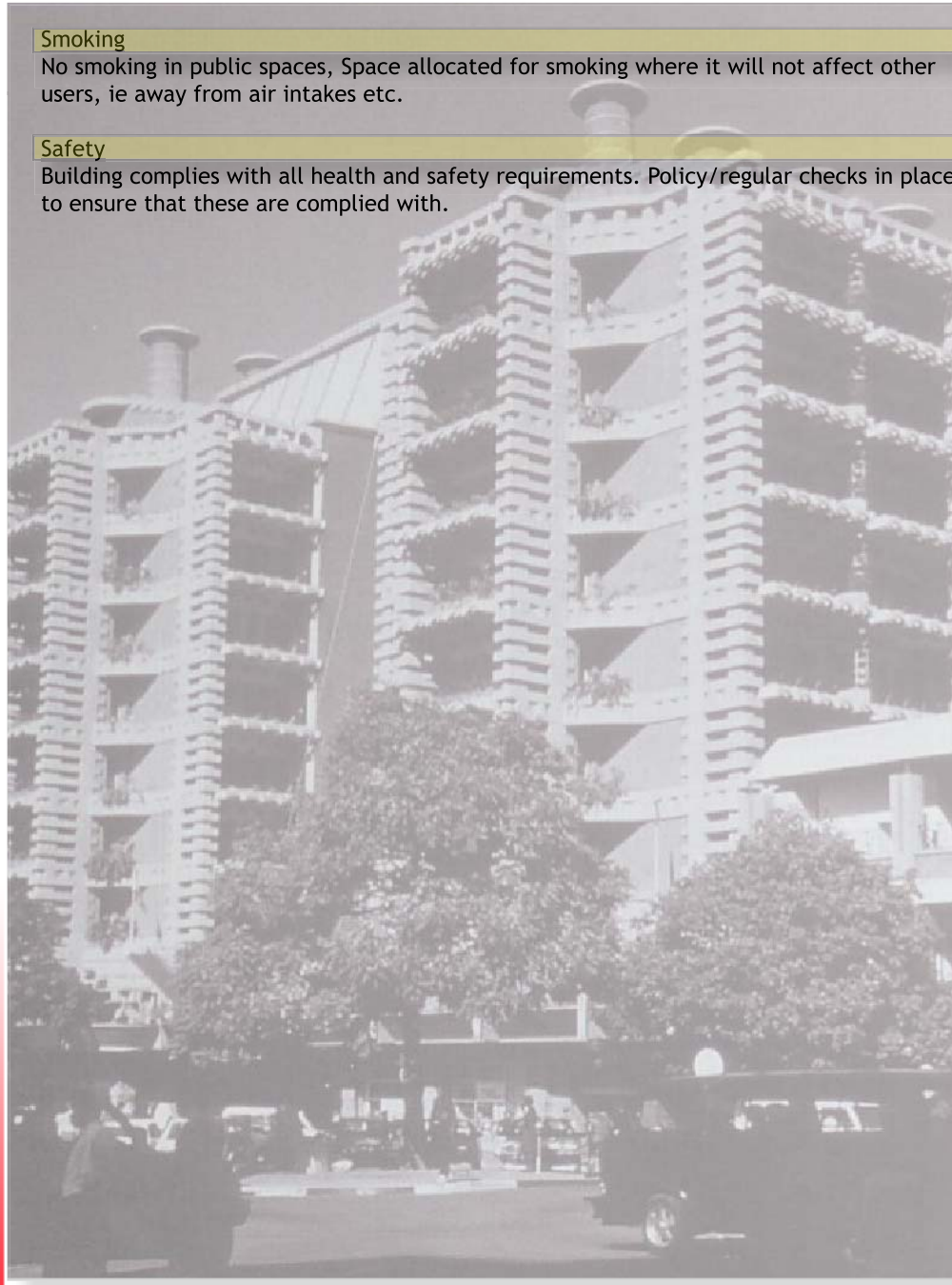

**ECONOMIC CONSIDERATIONS**

**Smoking**

No smoking in public spaces, Space allocated for smoking where it will not affect other users, ie away from air intakes etc.

**Safety**

Building complies with all health and safety requirements. Policy/regular checks in place to ensure that these are complied with.

**LOCAL ECONOMY**

The construction and management of buildings can have a major impact on the economy of an area. The economy of an area can be stimulated and sustained by buildings that make use and develop local skills and resources. (Gibberd 2003:144).

**Local contractors**

80% of the construction has been carried out by contractors based within 40km of the building/refurbishment.

**Local building material supply**

80% of construction materials: cement, sand, bricks etc produced within 200km of site'

**Local component manufacturer (Furniture?)**

80% of building components ie windows and doors produced locally (within 200km).

**Outsource opportunities**

Opportunities created and provision provided for small emerging businesses. This includes outsourcing catering, cleaning services and security as well as making space and equipment available for businesses to use for retail, education etc.

**Repairs and maintenance**

All repairs and maintenance required by the building (including servicing of mechanical plant) can be carried out by contractors within 200km of site.

**EFFICIENCY OF USE**

Buildings cost money and make use of resources whether they are used or not. Effective and efficient use of buildings supports sustainability by reducing waste and the need for additional buildings. (Gibberd 2003:144)

**Useable space**

Non useable space such plant, WCs and circulation does not make up more than 20% of total area.

**Occupancy**

Building and all working/living spaces are occupied for an average equivalent minimum of 30 hours per week.

**Space use**

Use of space intensified through space management approach and policy such as shared work spaces ie 'hot-desking'.

**Use of technology**

Communications and information technologies used to reduce space requirements ie video conference, teleworking etc.

**Space management**

Policy to ensure that space is well used. This may include regular audits, or space management system that charges space to cost centres.

**ADAPTABILITY AND FLEXIBILITY**

Most buildings can have a life-span of at least 50 years. It is likely that within this time that the use of the building will change, or that the feasibility of this will be investigated. Buildings which can accommodate change easily supports sustainability by reducing the requirement for change (energy, costs etc) and the need for new buildings. (Gibberd 2003:145).

**Spaces**

Spaces should be readily adapted for different uses. For instance spaces may be required for work during the day, social activities in the evening and quiet study during weekends and at night.

**Furniture**

Internal spaces can be easily reconfigured to suite different organisation requirements / users.

**Services**

Services can be configured to allow different internal arrangements and can be accessed easily to be extended / altered.

**Structure**

Structure / load bearing elements configured to enable variety of different internal arrangements.

**Vertical Circulation and Service Cores**

Vertical circulation and service cores configured to enable range of different spatial arrangements.

**ONGOING COSTS****Maintenance**

Specification and material specification for low maintenance and or low cost maintenance. All plant and fabric have a maintenance cycle of at least 2 years. Low or no maintenance components (ie windows, doors, plant, ironmongery etc) selected. Maintenance can be carried out cost effectively (ie replaceable items such as lightbulbs can be easily reached and replaced). (Gibberd 2003:145).

**Cleaning**

Measures taken to limit requirement for cleaning. Hard wearing solid flooring (limited or no carpeting) specified. Windows easily accessible for cleaning.

**Security / care taking**

Measures taken to limit the requirement and costs of security. This should include mixed use development (area is always occupied), buildings and spaces overlooked by occupied neighbouring buildings.

**Insurance / water / energy / sewerage**

Costs of insurance, water, energy and sewerage monitored. Consumption and costs regularly reported to management and users. Policy and management to reduce consumption (ie switching off lights on leaving building spaces) implemented.

**Disruption and 'downtime'**

Electrical and communication services, HVAC and plant located where they can be easily accessed with a minimum of disruption to occupants of building. This should maximise access to this from circulation areas (rather than work/living areas) and lift off panels at regular intervals to vertical and horizontal ducting.

**CAPITAL COSTS**

Buildings are generally one of the most valuable assets that people, and often organisations and governments own. Money spent on buildings is not available for other uses such as health and education. Often too, the high cost of buildings results in the services (ie health and education) and the accommodation (for work and living) is beyond the reach of people with the lowest incomes. Buildings that are cost effective support sustainability by helping provide access to accommodation and services for low income areas and by enabling money to be spent on other areas that support sustainability. (Gibberd 2003:146).

**Consultant fees**

Consultant fees not just calculated on total project cost basis. Incentives provided to consultants to reduce capital cost and ongoing costs.

**Build-ability**

Building designed to be easily and cheaply built. Building form simple. Replication of elements and components.

**Construction**

Construction approach designed to reduce initial capital cost of building. Building undertaken in a series of phases. Building built as shell first with finishes to be added later.

**Shared costs**

Cost of building shared with other users.

**Sharing arrangements**

Size and quantity of buildings reduced through arrangements to use existing spaces and buildings.

**WATER**

Water is required for many activities. However the large-scale provision of conventional water supply has many environmental implications. Water needs to be stored (sometimes taking up large areas of valuable land and disturbing natural drainage patterns with associated problems from erosion etc), it also needs to be pumped (using energy) through a large network of pipes (that need to be maintained and repaired). Having delivered the water, a parallel effort is then required to dispose of this after it is used, ie sewerage systems. Reducing water consumption supports sustainability by reducing the environmental impact required to deliver water, and dispose of this after use in a conventional system. (Gibberd 2003:147).

**Rainwater**

Rainwater is harvested, stored and used.

**Water use**

Water efficient devices.

**Grey water**

Grey water (water from washing etc) recycled (to flush toilets or water plants).

**Runoff**

Run off reduced by using pervious or absorbant surfaces. Hard landscaping minimised, previous surfaces specified for car parking and paths.

**Planting**

Planting has low water requirement (indigenous species).

**ENERGY**

Buildings consume about 50% of all energy produced. Conventional energy production is responsible for making a large contribution to environmental damage and non-renewable resource depletion. Using less energy or using renewable energy in buildings therefore can make a substantial contribution to sustainability. (Gibberd 2003:147).

**Location**

Building located within 400m of public transport.

**Ventilation System**

Passive ventilation system.

**Heating and Cooling System**

Passive environmental control system use.

**Appliances and Fittings**

Energy efficient fittings and devices specified. 80% of light fittings are fluorescent/low energy consumption.

**Renewable Energy**

Buildings uses electricity generated from renewable sources ie wind, sun.

**RECYCLING AND REUSE**

Raw materials and new components used in buildings consume resources and energy in their manufacture and processes. Buildings accommodate activities that consume large amounts of resources and products and produce large amounts of waste. Reducing the use of new materials and components in buildings and in the activities accommodated and reducing waste by recycling and reuse supports sustainability by reducing the energy consumption and resource consumption. (Gibberd 2003:148).

**Toxic waste**

Arrangements made for the safe disposal / recycling of toxic/harmful substances ie batteries, printer toners, vehicle oil.

**Inorganic waste**

Arrangements for sorting, storage and pick up of recyclable waste.

**Organic waste**

Recycled on site ie compost.

**Sewerage**

Contribution to mains sewerage from toilet minimised through use of compost toilets, and other 'local' systems.

**Construction waste**

Construction waste minimised through design careful management of construction practices. Design limits wastage by designing to comply with modular dimensions of materials etc.

**SITE**

Buildings have a footprint and a size that take up space that could otherwise be occupied by natural ecosystems which contribute to sustainability by helping create and maintain an environment that supports life. (By, for instance controlling the carbon dioxide and oxygen balance and maintaining temperatures within a limited range). Buildings can support sustainability by, limiting development to sites that have already been disturbed, and working with nature by including aspects of natural ecosystems within the development. (Gibberd 2003:149).

**Brownfield site**

Building constructed on a site already previously built on.

**Neighbouring buildings**

Building does not have harmful affect on neighbouring buildings ie over shading, where access to sunlight is important.

**Vegetation**

Site has extensive vegetation. Opportunities have been taken to plant in car parking areas, and in and around buildings ie atriums, window boxes and roof gardens.

**Habitat**

Site has provide habitats for animals. This includes a coordinated landscaping strategy that takes into account planting, water and habitat etc.

**Landscape inputs**

Landscape does not require heavy artificial input i.e. fertilizer, insecticide and pesticide.

**MATERIALS AND COMPONENTS**

The construction of buildings usually requires large quantities of materials and components. These may require large amounts of energy to produce. Their development may also require process that are harmful to the environment and consume non-renewable resources. (Gibberd 2003:149).

**Embodied energy**

80% of the building materials and components made from materials and components with low embodied energy. Low embodied energy materials include locally (within country) made and sourced timber, concrete, concrete block timber windows and doors.

**Material / component sources**

90% of materials and resources from renewable resources.

**Manufacturing processes**

Environmental damage limited during product component development. No green house gases released, no pollution caused.

**Recycled / reused materials and components**

10% of building materials and components are reused or from recycled sources.

**Construction processes**

Building and construction process designed to minimally impact the environment. Requirement for large scale vegetatjon clearing and earth movement minimized.

**SUSTAINABILITY AND BUILDING MATERIALS**

It is important to thouroughly understand the implications of the building materials selected for any particular building, and their environmental impact. 3 of some of the most commonly used materials, namely aluminium, steel, and concrete are good examples of how the aesthetic appeal comes with high hidden embodied energy requirements.

**ALUMINIUM**

Aluminium has come to symbolize the essence of progress in architecture, and the proud finish in high-tech architecture. However the production of aluminium represents one of the most extreme forms of resource abuse.

Made from bauxite ore, aluminium is the product of a finite commodity, calculated as a world reserve of little more than 24.0 billion metric tons. The majority of of this resource, other than the 4.44 billion metric tons found in Australia, is located in the developing, primarily in Guinea (5.6 billion metric tons), Jamaica (2.0 billion metric tons), India (1.0 billion metric tons), and Brazil (2.8 billion metric tons). Bauxite is extracted primarily by strio mining, which scars the landscape and creates general environmental disruption. (Steele 1997:209).

Aluminium is commonly manufactured using the Hall-Heroult electrolytic reduction process. This process takes place in a smelter, wherin alumina powder is is dissolved in long narrow carbon-lined vats containing molten cryolite, or sodium-aluminium flouride. An anode is lowered into the bath transfers 250,000 Ampere of electricity through it, sperating the alumina molecules into aluminium. The aluminium is periodically drawn out of the vats during the process, which never stops. After processing, the aluminium is fabricated through various techniques, including casting, extrusion, and rolling, and may be painted or anodized. (Steele 1997:209).

The extensive amount of energy needed to process aluminium, the substantial toxic waste generated, and the extensive requirements for fresh water qualify qualifies the product as containing a high embodied energy.

**CONCRETE**

Cement which makes up 10 to 20% of a concrete mixture is the most energy-intensive component to produce. It is manufactured by heating limestone with clay. The materials are fed into into a long sloping sloping rotary kiln, which has progressively hotter zones, eventually reaching 1480 degrees Celsius. As it rotates, the kiln slowly mixes the contents moving through it, generating the neccessary chemical reaction, through hydration. Neraly 1500 kg of limestone and clay, or shale, are required tp produce 1 ton of finished cement. A great deal of carbon dioxide, as well as nitrous oxide, sulphur, and other pollutans are generated by the coal used to heat the kiln. (Steele 1997:210)

STEEL

Steel is made from iron ore, which is mostly found in developed countries. Reserves estimated at approximately 65 billion metric tons are found in the following countries: Australia (10,2 billion metric tons), Canada (4,6 billion metric tons), United States (3,8 billion metric tons), South Africa (2,5 billion metric tons), and Sweden (1,6 billion metric tons). An addition 14,5 billion metric tons is found in developing countries, such as Brazil, Venezuela, China and India.

The basic ingredients in steel production, iron ore, limestone, and coal, are each produced in complicated processes of their own, making this the most energy-intensive of all construction materials. (Steele 1997:226).

The 3 selected materials provide an example of how much natural resources go into manufacturing some of the most commonly used construction materials. Architects need to be more aware and selective of their choice of materials based on their environmental impact.

ENERGY SOURCES

In a world of constantly diminishing renewable resources it becomes imperative to take advantage of the most commonly available energy source-the sun. It is a good source for light, heat, and sometimes even electricity. In the context of South Africa, the moderate climate allows for the exploitation of the outdoor environment. Buildings should be orientated to capitalize on the ample available daylight, however, the effects of solar heat loading should be clearly understood. For example the roof takes 60% of the heat load, and that the north facade takes 30% and 20% of the heat load in summer and winter respectively.

Climatic wind conditions should be analyzed and the orientation and design should respond accordingly, the provision of openable windows allows a building to ventilate naturally, and increases the amount of fresh air circulating. Generally, air-conditioned buildings are sealed-off altogether to assist the technical requirements of the mechanical system, the result is that only 5 to 10% of the air is usually fresh-air, opposed to 30 to 40% in naturally ventilating buildings.

TABLE 2 Embodied energy of materials

MATERIAL	EMBODIED ENERGY	
	MJ/ kg	MJ/m <sup>3</sup>
Aggregate	0.1	150
Straw bale	0.24	91
Soil-cement	0.42	819
Stone (local)	0.79	2030
Concrete block	0.94	2950
Concrete (30Mpa)	1.3	3180
Concrete precast	2.0	2780
Lumber	2.5	1380
Brick	2.5	5170
Cellulose insulation	3.3	112
Gypsum wallboard	6.1	5890
Particle board	8.0	4400
Aluminium (recycled)	8.1	21870
Steel (recycled)	8.9	37210
Shingles (asphalt)	9.0	4990
Plywood	10.4	5720
Mineral wool insulation	14.6	139
Glass	15.9	37550
Fibreglass insulation	90.3	970
Steel	32.0	251200
Zinc	51.0	371200
Brass	62.0	519580
PVC	70.0	93620
Copper	70.6	631164
Paint	93.3	117500
Linoleum	116	150930
Polystyrene insulation	117	3770
Carpet (synthetic)	148	84900
Aluminium	227	515700

Note: Embodied energy values are based on several international sources – local values may vary. These values are to be used as a guide only.

(Astrup 2005)

## SBAT ASSESSMENT CRITERIA

The building performance is assessed in terms of sustainability, using the SBAT principles. The first step is to set the realistic targets that the design will strive to achieve, thereafter the building's social, economic, and environmental performance is assessed.

## TARGET SETTING

TABLE 3 Target setting table

	Criteria	No Requirement 1	Low Requirement 2	Medium Requirement 3	High Requirement 4	Essential 5
<b>SO</b>	<b>Social</b>					
SO1	Occupant Comfort					*
SO2	Inclusive Environments					*
SO3	Access to Facilities					*
SO4	Participation and Control					*
SO5	Education Health and Safety					*
<b>EC</b>	<b>Economic</b>					
EC1	Local Economy					*
EC2	Efficiency of Use					*
EC3	Adaptability and Flexibility					*
EC4	Ongoing Costs				*	
EC5	Capital Costs					*
<b>EN</b>	<b>Environmental</b>					
EN1	Water			*		
EN2	Energy				*	
EN3	Waste			*		
EN4	Site				*	
EN5	Materials and Components			*		

(Gibberd 2003:140).

## BUILDING PERFORMANCE - SOCIAL

Criteria	Indicative performance measure	Measured	Points
<b>SO 1 Occupant Comfort</b>		<u>Explanatory notes</u>	<b>4.5</b>
SO 1.1 Daylighting	% of occupied spaces that are within distance 2H from window, where H is the height of the window or where there is good daylight from skylights	100	1.0
SO 1.2 Ventilation	% of occupied spaces have equivalent of opening window area equivalent to 10% of floor area or adequate mechanical system, with unpolluted air source	100	1.0
SO 1.3 Noise	% of occupied spaces where external/internal/reverberation noise does not impinge on normal conversation (50dba)	80	0.8
SO 1.5 Thermal comfort	Temperature of occupied space does not exceed 28 or go below 19°C for less than 5 days per year (100%)	80	0.8
SO 1.5 Views	% of occupied space that is 6m from an external window (not a skylight) with a view	90	0.9
<b>SO 2 Inclusive Environment</b>		<u>Explanatory notes</u>	<b>4.2</b>
SO 2.1 Public Transport	% of building (s) within 400m of disabled accessible (20%) and affordable (80%) public transport	100	1.0
SO 2.2 Information	Comprehensive signage provided (50%), Signage high contrast, clear print signage in appropriate locations and language(s) / use of understandable symbols / manned reception at all entrances (50%)	70	0.7
SO 2.3 Space	% of occupied spaces that are accessible to ambulant disabled / wheelchair users	80	0.8
SO 2.4 Toilets	% of occupied space with fully accessible toilets within 50m along easily accessible route	100	1.0
SO 2.5 Fittings & Furniture	% of commonly used furniture and fittings (reception desk, kitchenette, auditorium) fully accessible	70	0.7
<b>SO 3 Access to Facilities</b>		<u>Explanatory notes</u>	<b>3.8</b>
SO 3.1 Children	All users can walk (100%) / use public transport (50%) to get to their childrens' schools and creches	70	0.7
SO 3.2 Banking	All users can walk (100%) / use public transport (50%) to get to banking facilities	100	1.0
SO 3.3 Retail	All users can walk (100%) / use public transport (50%) to get to food retail	70	0.7
SO 3.4 Communication	All users can walk (100%) / use public transport (50%) to get to communication facilities (post/telephone/internet)	70	0.7
SO 3.5 Exercise	All users can walk (100%) / use public transport (50%) to get to recreation/exercise facilities	70	0.7
<b>SO 4 Participation &amp; Control</b>		<u>Explanatory notes</u>	<b>4.5</b>
SO 4.1 Environmental control	% of occupied space able to control their thermal environment (adjacent to openable windows/thermal controls)	80	0.8
SO 4.2 Lighting control	% of occupied space able to control their light (adjacent to controllable blinds etc/local lighting control)	80	0.8
SO 4.3 Social spaces	Social informal meeting spaces (parks / staff canteens / cafes) provided locally (within 400m) (100%)	100	1.0
SO 4.4 Sharing facilities	5% or more of facilities shared with other users / organisations on a weekly basis (100%)	90	0.9
SO 4.5 User group	Users actively involved in the design process (50%) / Active and representative management user group (50%)	100	1.0
<b>SO 5 Education, Health &amp; Safety</b>		<u>Explanatory notes</u>	<b>4.0</b>
SO 5.1 Education	Two percent or more space/facilities available for education (seminar rooms / reading / libraries) per occupied space (75%). Construction training provided on site (25%)	100	1.0
SO 5.2 Safety	All well used routes in and around building well lit (25%), all routes in and around buildings visually supervised (25%), secure perimeter and access control (50%), No crime (100%)	90	0.9
SO 5.3 Awareness	% of users who can access information on health & safety issues (ie HIV/AIDS), training and employment opportunities easily (posters/personnel/intranet site)	50	0.5
SO 5.4 Materials	All materials/components used have no negative effects on indoor air quality (100%)	100	1.0
SO 5.5 Accidents	Process in place for recording all occupational accidents and diseases and addressing these	60	0.6

(Gibberd)



BUILDING PERFORMANCE - **ECONOMICAL**

Criteria	Indicative performance measure	Measured	Points
<b>EC 1</b>	<b>Local economy</b>	<u>Explanatory notes</u>	<b>4.2</b>
EC 1.1	Local contractors	% value of the building constructed by local (within 50km) small (employees<20) contractors	80 0.8
EC 1.2	Local materials	% of materials (sand, bricks, blocks, roofing material) sourced from within 50km	80 0.8
EC 1.3	Local components	% of components (windows, doors etc) made locally (in the country)	90 0.9
EC 1.4	Local furniture/fittings	% of furniture and fittings made locally (in the country)	90 0.9
EC 1.5	Maintenance	% of maintenance and repairs by value that can, and are undertaken, by local contractors (within 50km)	80 0.8
<b>EC 2</b>	<b>Efficiency</b>	<u>Explanatory notes</u>	<b>4.4</b>
EC 2.1	Capacity	% capacity of building used on a daily basis (actual number of users / number of users at full capacity*100)	90 0.9
EC 2.2	Occupancy	% of time building is occupied and used (actual average number of hours used / all potential hours building could be used (24) *100)	80 0.8
EC 2.3	Space per occupant	Space provision per user not more than 10% above national average for building type (100%)	90 0.9
EC 2.4	Communication	Site/building has access to internet and telephone (100%), telephone only (50%)	100 1.0
EC 2.5	Material & Components	Building design coordinated with material / component sizes in order to minimise wastage. Walls (50%), Roof and floors (50%)	80 0.8
<b>EC 3</b>	<b>Adaptability</b>	<u>Explanatory notes</u>	<b>4.2</b>
EC 3.1	Vertical heights	% of spaces that have a floor to ceiling height of 3000mm or more	100 1.0
EC 3.2	External space	Design facilitates flexible external space use (100%)	90 0.9
EC 3.3	Internal partition	Non loadbearing internal partitions that can be easily adapted (loose partitioning (100%), studwall (50%), masonry (25%))	90 0.9
EC 3.4	Modular planning	Building with modular structure, envelope (fenestration) & services allowing easy internal adaptation (100%)	60 0.6
EC 3.5	Furniture	Modular, limited variety furniture - can be easily configured for different uses (100%)	80 0.8
<b>EC 4</b>	<b>Ongoing costs</b>	<u>Explanatory notes</u>	<b>3.2</b>
EC 4.1	Induction	All new users receive induction training on building systems (50%), Detailed building user manual (50%)	0 0.0
EC 4.2	Consumption & waste	% of users exposed on a monthly basis to building performance figures (water (25%), electricity (25%), waste (25%), accidents (25%))	60 0.6
EC 4.2	Metering	Easily monitored localised metering system for water (50%) and energy (50%)	70 0.7
EC 4.3	Maintenance & Cleaning	% of building that can be cleaned and maintained easily and safely using simple equipment and local non-hazardous materials	100 1.0
EC 4.5	Procurement	% of value of all materials/equipment used in the building on a daily basis supplied by local (within the country) manufacturers	90 0.9
<b>EC 5</b>	<b>Capital Costs</b>	<u>Explanatory notes</u>	<b>3.5</b>
EC 5.1	Local need	Five percent capital cost allocated to address urgent local issues (employment, training etc) during construction process (100%)	90 0.9
EC 5.2	Procurement	Tender / construction packaged to ensure involvement of small local contractors/manufacturers (100%)	90 0.9
EC 5.3	Building costs	Capital cost not more than fifteen % above national average building costs for the building type (100%)	70 0.7
EC 5.4	Technology	3% or more of capital costs allocated to new sustainable/indigenous technology (100%)	30 0.3
EC 5.5	Existing Buildings	Existing buildings reused (100%)	70 0.7

(Gibberd)

**BUILDING PERFORMANCE - ENVIRONMENTAL**

	Criteria	Indicative performance measure	Measured	Points
<b>EN 1</b>	<b>Water</b>		Explanatory notes	<b>3.1</b>
EN 1.1	Rainwater	% of water consumed sourced from rainwater harvested on site	40	0.4
EN 1.2	Water use	% of equipment (taps, washing machines, urinals showerheads) that are water efficient	100	1.0
EN 1.3	Runoff	% of carparking, paths, roads and roofs that have absorbant/semi absorbant/permeable surfaces (grassed/thatched/looselaid paving/ absorbant materials)	80	0.8
EN 1.4	Greywater	% of water from washing/relatively clean processes recycled and reused	0	0.0
EN 1.5	Planting	% of planting (other than food gardens) on site with low / appropriate water requirements	90	0.9
<b>EN 2</b>	<b>Energy</b>		Explanatory notes	<b>3.5</b>
EN 2.1	Location	% of users who walk / cycle / use public transport to commute to the building	80	0.8
EN 2.2	Ventilation	% of building ventilation requirements met through natural / passive ventilation	70	0.7
EN 2.3	Heating & Cooling	% of occupied space which relies solely on passive environmental control (no or minimal energy consumption)	50	0.5
EN 2.4	Appliances & fittings	% of appliances / lighting fixtures that are classed as highly energy efficient ( ie energy star rating)	90	0.9
EN 2.5	Renewable energy	% of building energy requirements met from renewable sources	60	0.6
<b>EN 3</b>	<b>Waste</b>		Explanatory notes	<b>0.9</b>
EN 3.1	Toxic waste	% of toxic waste (batteries, ink cartridges, flourescent lamps) recycled	10	0.1
EN 3.2	Organic waste	% of organic waste recycled	0	0.0
EN 3.3	Inorganic waste	% of inorganic waste recycled.	80	0.8
EN 3.4	Sewerage	% of sewerage recycled on site	0	0.0
EN 3.5	Construction waste	% of damaged building materials / waste developed in construction recycled on site	0	0.0
<b>EN 4</b>	<b>Site</b>		Explanatory notes	<b>2.6</b>
EN 4.1	Brownfield site	% of proposed site already disturbed / brownfield (previously developed)	80	0.8
EN 4.2	Neighbouring buildings	No neighbouring buildings negatively affected (access to sunlight, daylight, ventilation) (100%)	70	0.7
EN 4.3	Vegetation	% of area of area covered in vegetation (include green roofs, internal planting) relative to whole site	30	0.3
EN 4.4	Food gardens	Food gardens on site (100%)	0	0.0
EN 4.5	Landscape inputs	% of landscape that does not require mechanical equipment (ie lawn cutting) and or artificial inputs such as weed killers and pesticides	80	0.8
<b>EN 5</b>	<b>Materials &amp; Component</b>		Explanatory notes	<b>3.1</b>
EN 5.1	Embodied energy	Materials with high embodied energy (aluminium,plastics) make up less than 1% of weight of building (100%)	80	0.8
EN 5.2	Material sources	% of materials and components by volume from grown sources (animal/plant)	30	0.3
EN 5.3	Ozone depletion	No materials and components used requiring ozone depleting processes (100%)	70	0.7
EN 5.4	Recyled / reuse	% of materials and components (by weight) reused / from recycled sources	40	0.4
EN 5.5	Construction process	Volume / area of site disturbed during construction less than 2X volume/area of new building (100%)	90	0.9

(Gibberd)

SBAT ASSESSMENT RESULTS

The sustainable building performance outcomes for the Pretoria station interchange development are indicated in the chart below. The building performs reasonably well in the social and economic section, but falls quite short on the environmental aspects. The SBAT analysis has helped identify areas of sustainability concern, and also areas of positive impacts.

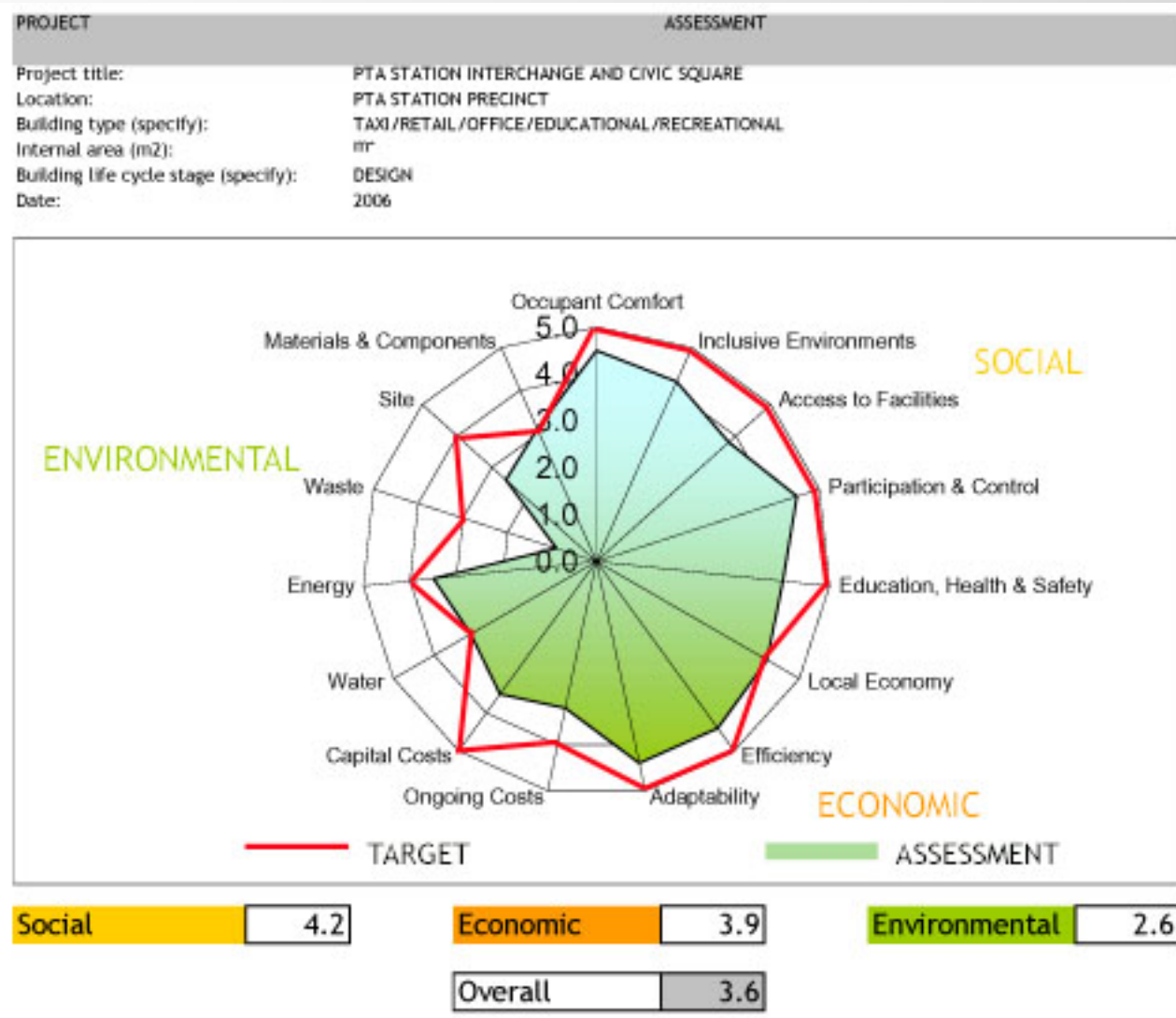

Figure 3.7.1 SBAT results chart

## DERMOGRAPHICS - GAUTENG PROVINCE

## POPULATION

The Gauteng province accounts for 1.4% of the 1 219 090 km<sup>2</sup> total land area of South Africa. However, the province is home to 19,7% of the estimated 44 million population. The city of Tshawne has a population of approximately 1,5 million people.

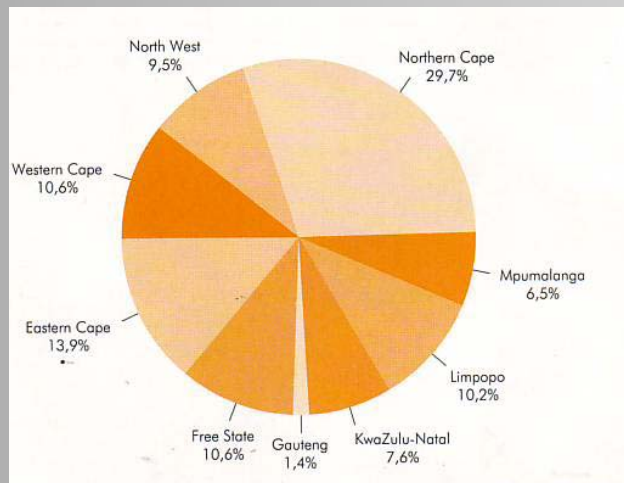

Figure 3.8.1 Land provincial allocation (Census 2001)

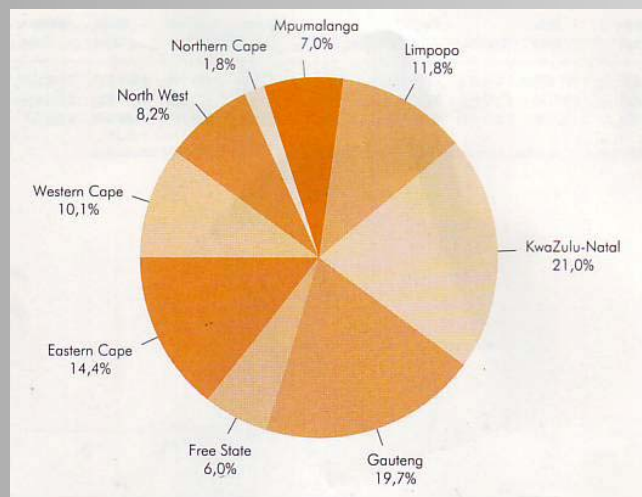

Figure 3.8.2 Population provincial allocation (Census 2001)

## EDUCATION

Statistics reveal that only 8,4% of the 8,8 million people have higher education qualification. 20,4% have matric qualifications, 38% have some secondary school exposure, and an alarming 17,9% have no schooling altogether.

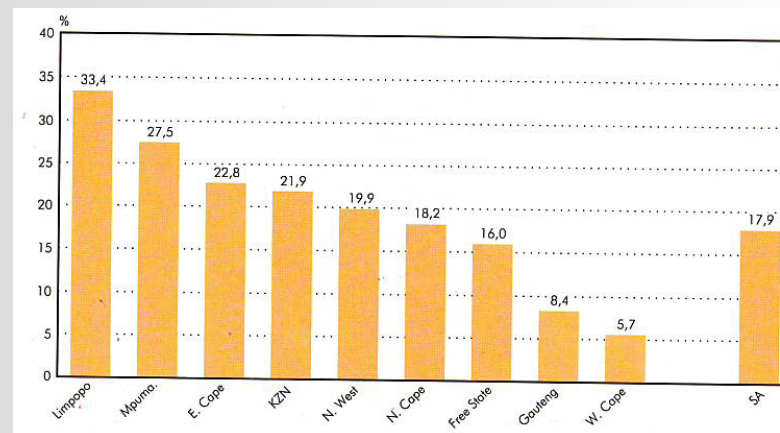

Figure 3.8.3 Percentage of people aged 20 and over with no education (Census 2001)

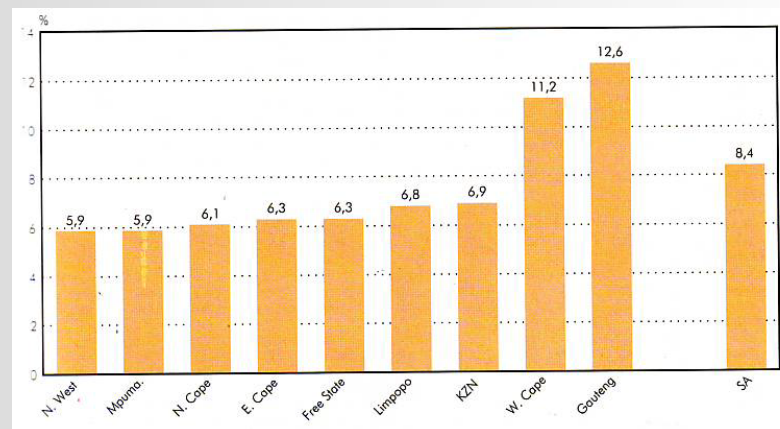

Figure 3.8.4 Percentage of people aged 20 and over tertiary education (Census 2001)

## ECONOMY

Based on Censuss 2001 statistics, 50,4% of the population is economically active, 19,9% is unemployed, while 29,7% is not economically active.

## CHAPTER 4

Page 64-147

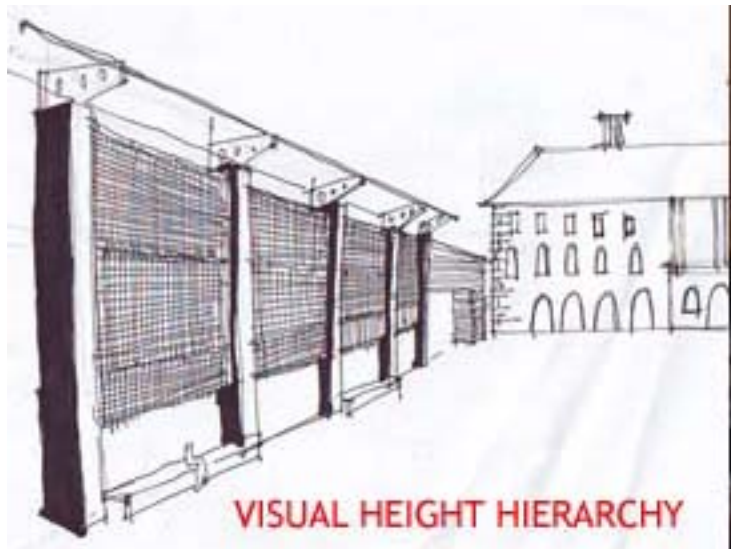

VISUAL HEIGHT HIERARCHY

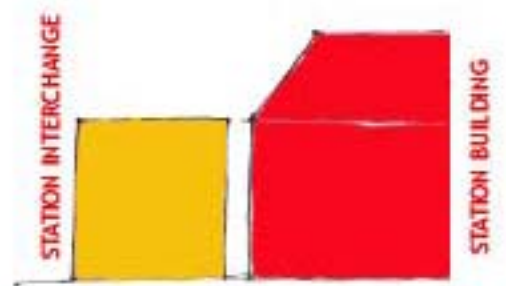

BUILDING PROMINENCE TO BE ARTICULATED BY HEIGHT (BACON),  
THUS THE EXISTING STATION AFFORDED DOMINANCE.

QUALITY PUBLIC URBAN SPACES AT THE FOCAL POINTS AND IN FRONT OF AND  
AROUND BUILDINGS OF HISTORICAL SIGNIFICANCE (PAUL KRUGER STREET SPINE)



HISTORIC SIGNIFICANCE OF THE PRETORIA STATION RESPECTED AND OBSERVED.  
THE FUNCTIONALIST APPROACH ADVOCATES THE PRESERVATION OF HISTORICALLY  
SIGNIFICANT BUILDINGS FOR HERITAGE AND EDUCATIONAL VALUES.  
  
THE FORMALIST IDEAL IS REFLECTED THROUGH UNDERSTANDING THE TIMELESS  
QUALITIES OF CULTURAL AND URBAN HERITAGE



AXIS OF EXPRESSION

MIXED-USE PRECINCT  
PRETORIA STATION SQUARE WITH RETAIL,  
OFFICES, LUXURY BUS TERMINUS.  
(PAUL KRUGER STREET SPINE)

INTERGRATION OF THE PUBLIC TRANSPORT  
SYSTEM WITH THE PEDESTRIAN NETWORK  
(PAUL KRUGER STREET SPINE)

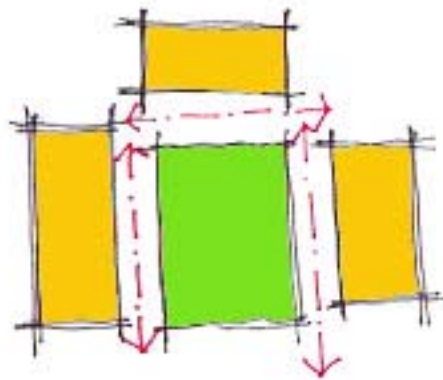

**SQUARE DEFINED BY BUILDINGS IN A U-SHAPE**  
Opening up to it, and fully accessible by means of pedestrian walkways

**URBAN SPACE**-“space between buildings in towns and other localities.”  
KRIER

- CIVIC SQUARE ACTIVITIES**
- RECREATION/LEISURE
  - TOURISM
  - INFORMAL TRADE/MARKETS
  - THOROUGHFARE
  - RELIGIOUS GATHERINGS
  - OPEN-AIR ENTERTAINMENT
  - POLITICAL RALLIES
  - LIVE BROADCASTS
  - PAUSE SPACE

**UBUNTU**

Similarly to urban planning principles, the pattern of traditional homesteads is characterized by a centrally placed courtyard. This courtyard is the communal social space. The Rooms are usually just the shelter spaces at night and during undesirable weather.

**FUNCTIONALIST**- Promotes communal intercation (civic) in the city core.

**HUMANIST**- Concerned with the social domain in architecture.

**THE SQUARE AND THE STREET DEFINE THE STREET (KRIER)**

Ideally, equilibrium of commercial and cultural activities should be maintained in any public square, dependant upon location, such a square should cater for diurnal and nocturnal activities.

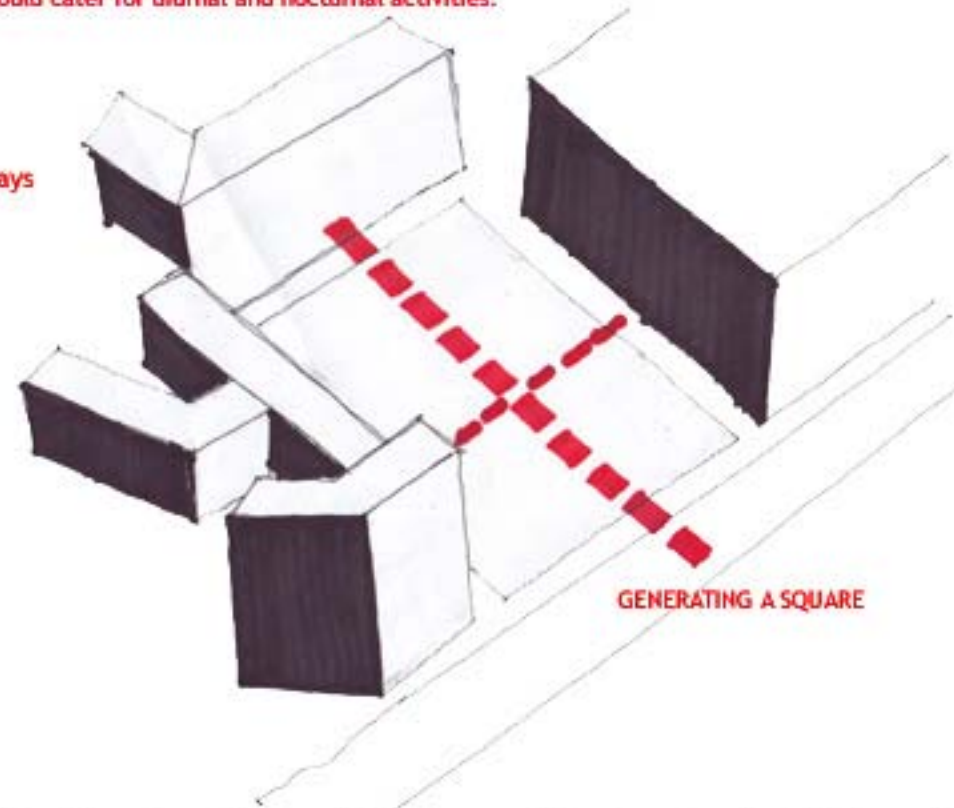

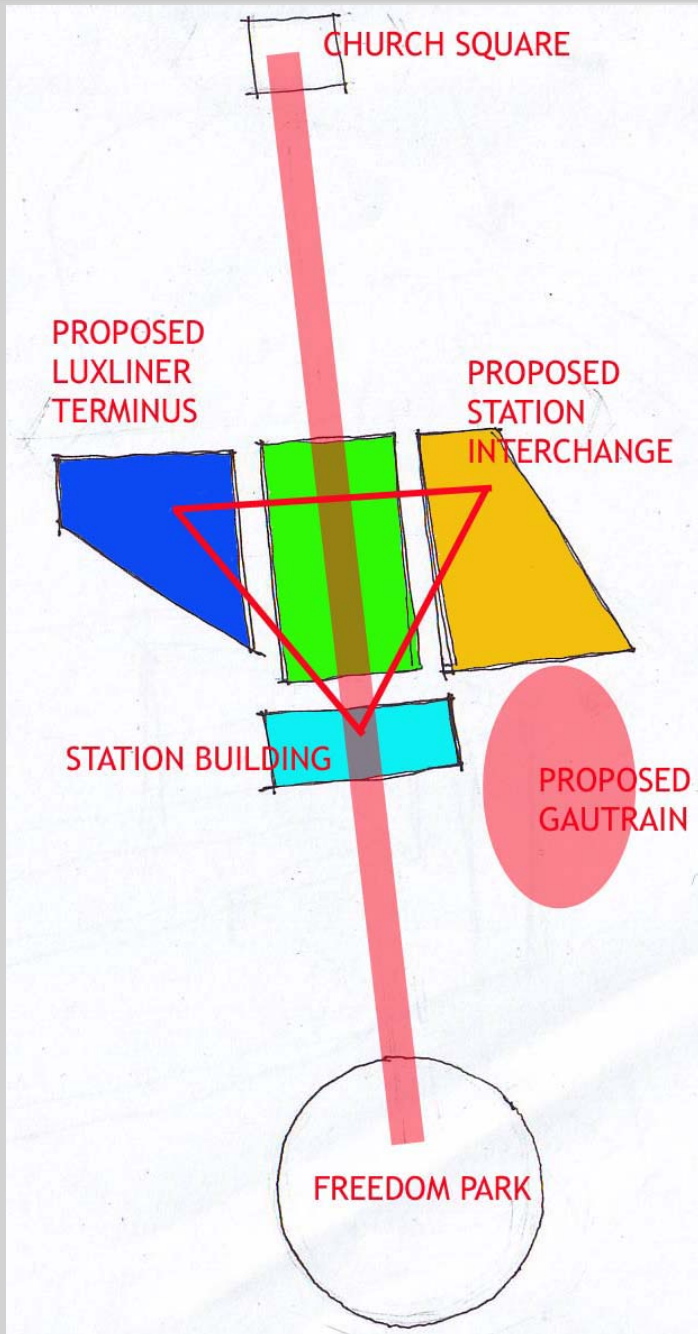

**IMPACT OF SURROUNDING DEVELOPMENT.**

The positioning of the proposed new luxliner terminus, combined with the existing station building, and proposed station interchange enhance the intermodal status of the Pretoria station.

The locationing of the 3 forms of transport modes create a triangular shaped interdependent link. The result is that the developments frame the civic space, thus creating a vibrant and defined public square.

An opportunity exists to make the Pretoria station the gateway into the city, the point of orientation, and an intermodal interchange reflective of the Capital city status.



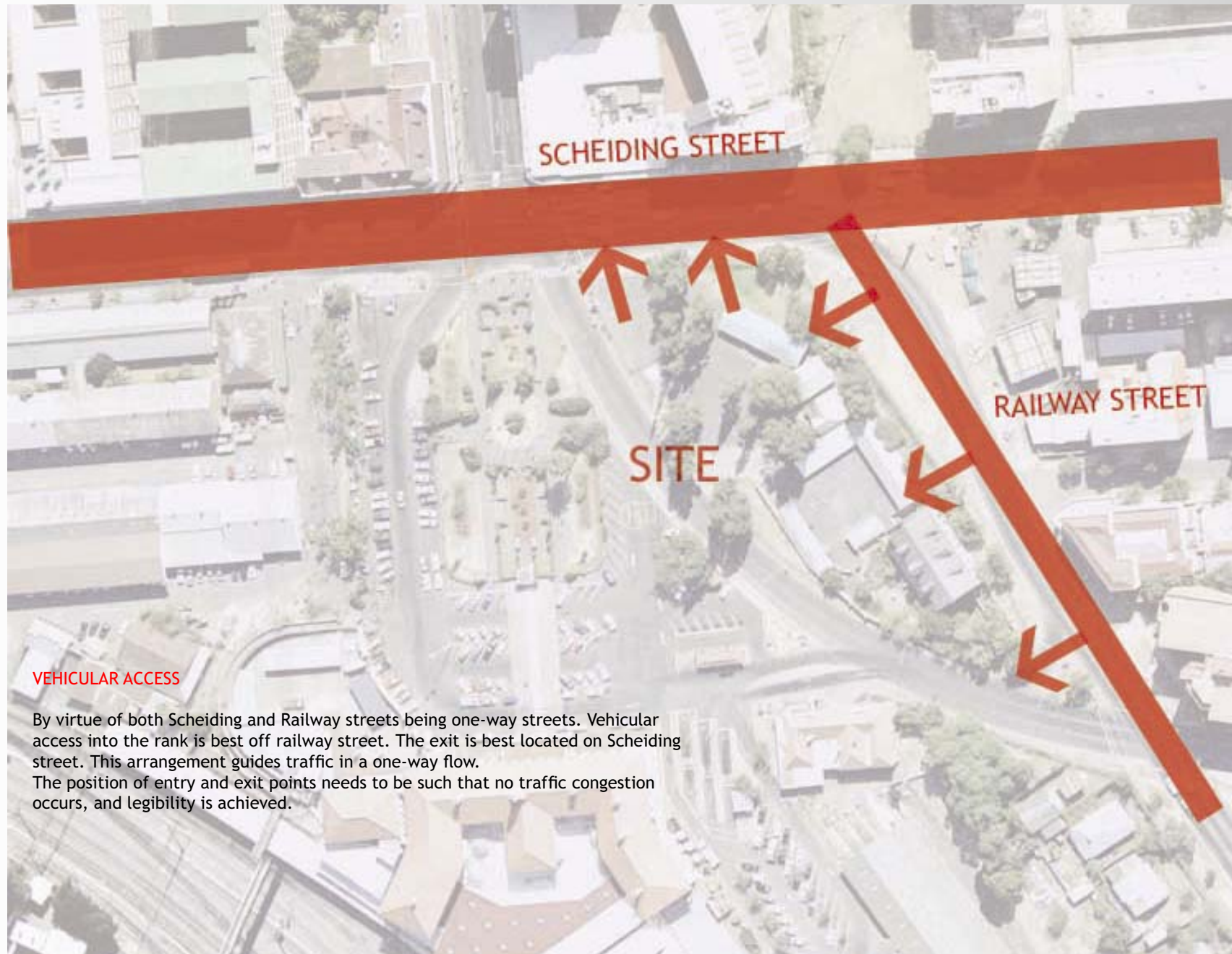

#### VEHICULAR ACCESS

By virtue of both Scheiding and Railway streets being one-way streets. Vehicular access into the rank is best off railway street. The exit is best located on Scheiding street. This arrangement guides traffic in a one-way flow. The position of entry and exit points needs to be such that no traffic congestion occurs, and legibility is achieved.



**CONCENTRATION OF PEDESTRIAN MOVEMENT AROUND THE SQUARE**

The movement pattern on the the square is informed by the existing paths, most especially the north-south axis leading from Paul Kruger street. The intervention follows the Systemic school of thought by prioritising existing patterns, especially movement and shelter.

**CONCENTRATION OF PEDESTRIAN MOVEMENT AROUND PRECINCT**

People walk the 400m distance between Pretoria station, Bosman station and the Bosman taxi rank. The major pedestrian movement is in a north-south axis, heading into the city, with some eastward movement heading towards the Sunnyside area.

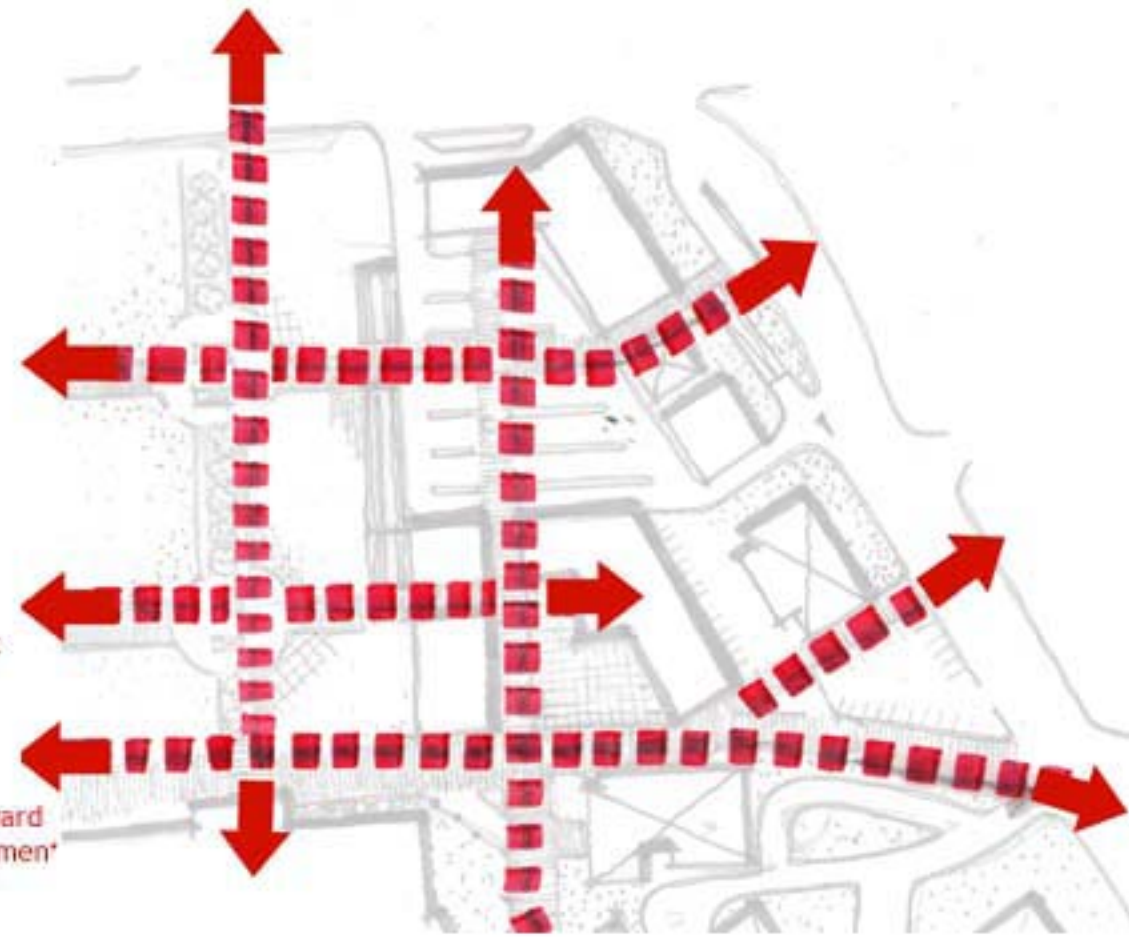
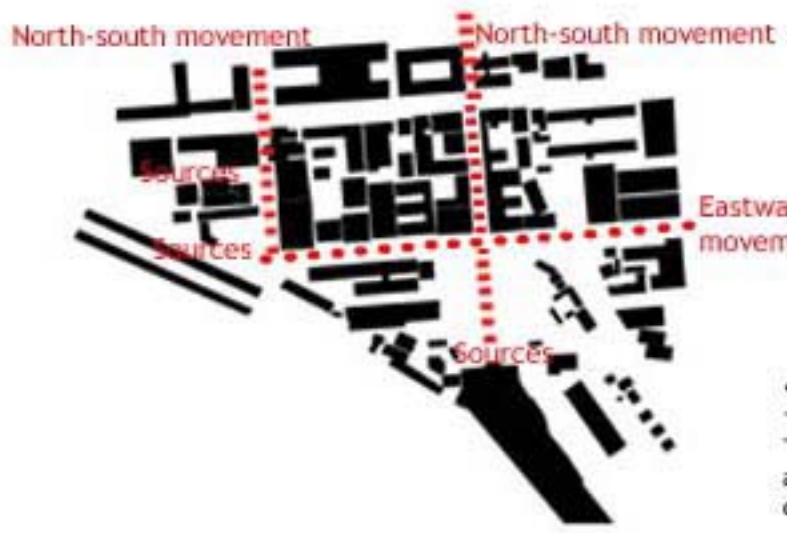

*'Walking is the most ubiquitous form of movement, open to almost everybody'* (Green and Roberts 1998)

The civic square is designed to compliment the axis of expression from Paul Kruger street by means of a prominent walkway axial extension stretching to the Pretoria station building. Traffic will be slowed down at the intersection of Scheiding street and Paul Kruger street to afford priority to pedestrians.

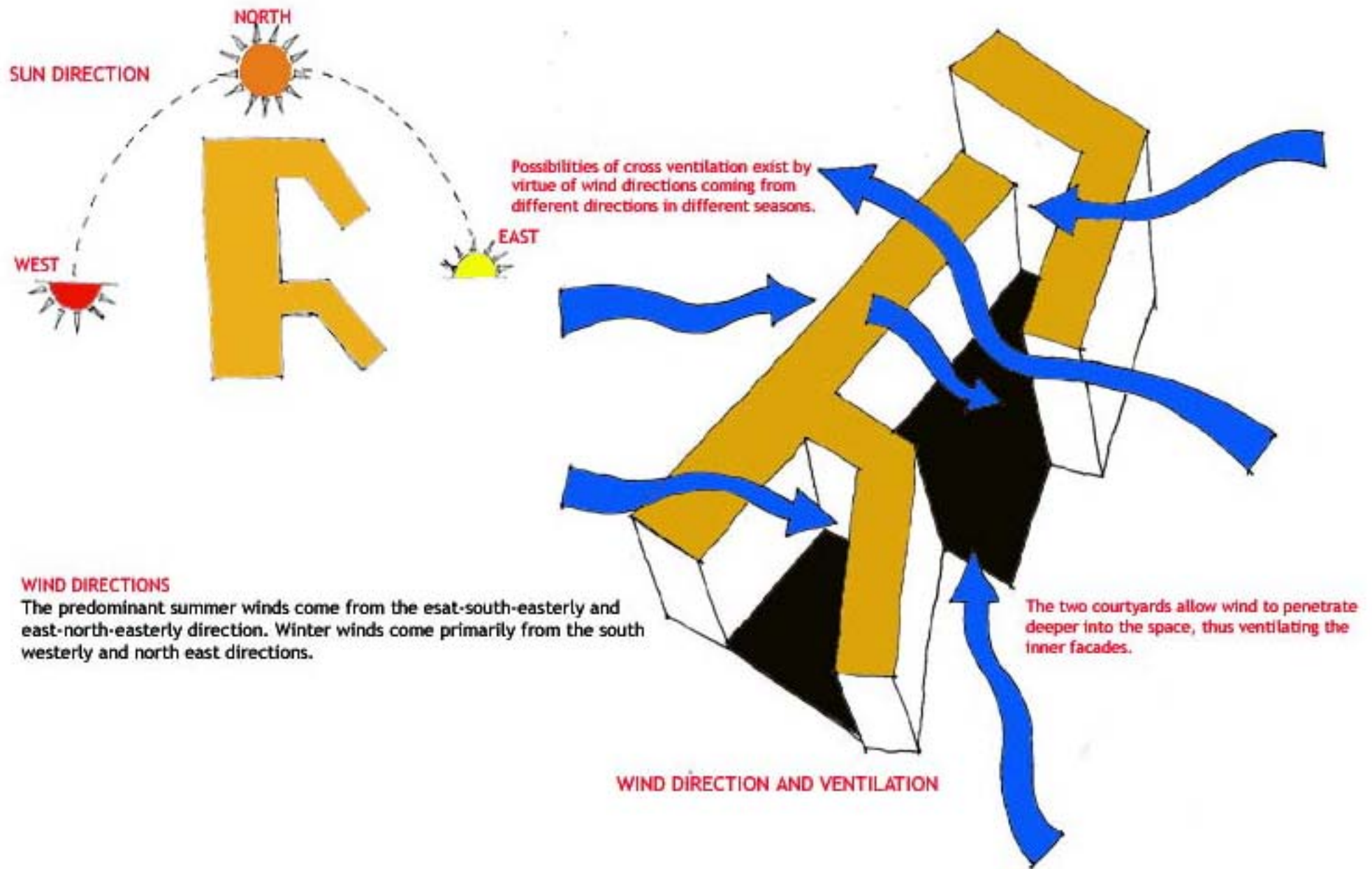

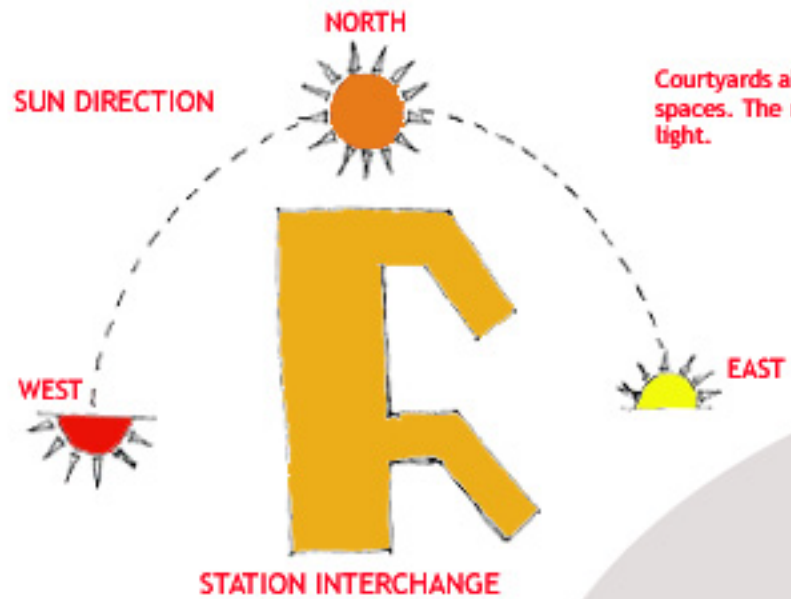

Courtyards allow light to penetrate deeper into the interior spaces. The result is that all the interior spaces have sufficient light.

SUN ANGLES AT NOON

SUMMER	87 Degrees
SOLSTICE	64 Degrees
WINTER	44 Degrees

WEST SUN EXPOSED FACADE

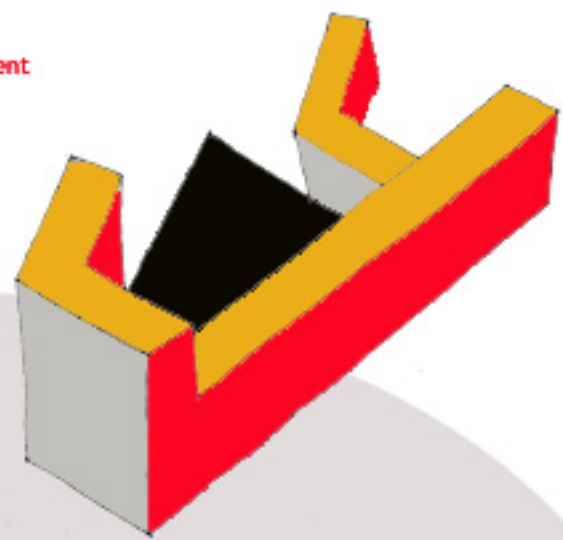

NORTH SUN EXPOSED FACADE

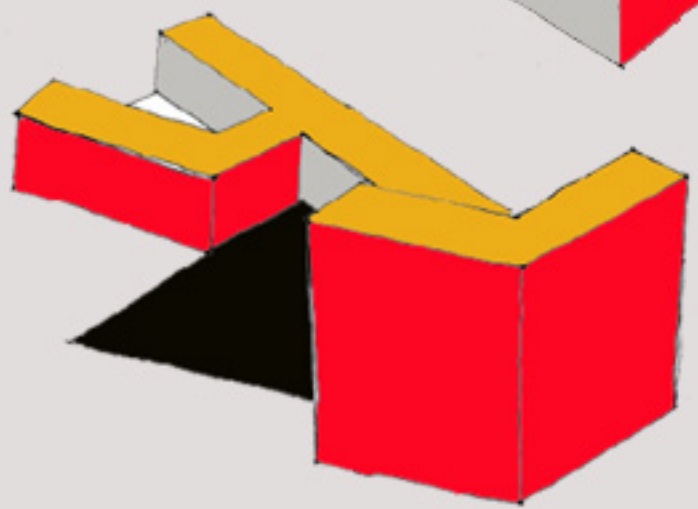

EAST SUN EXPOSED FACADE

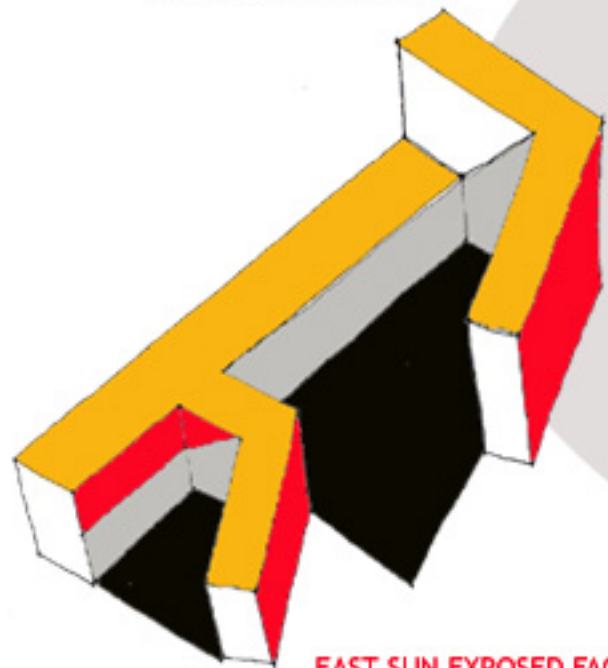

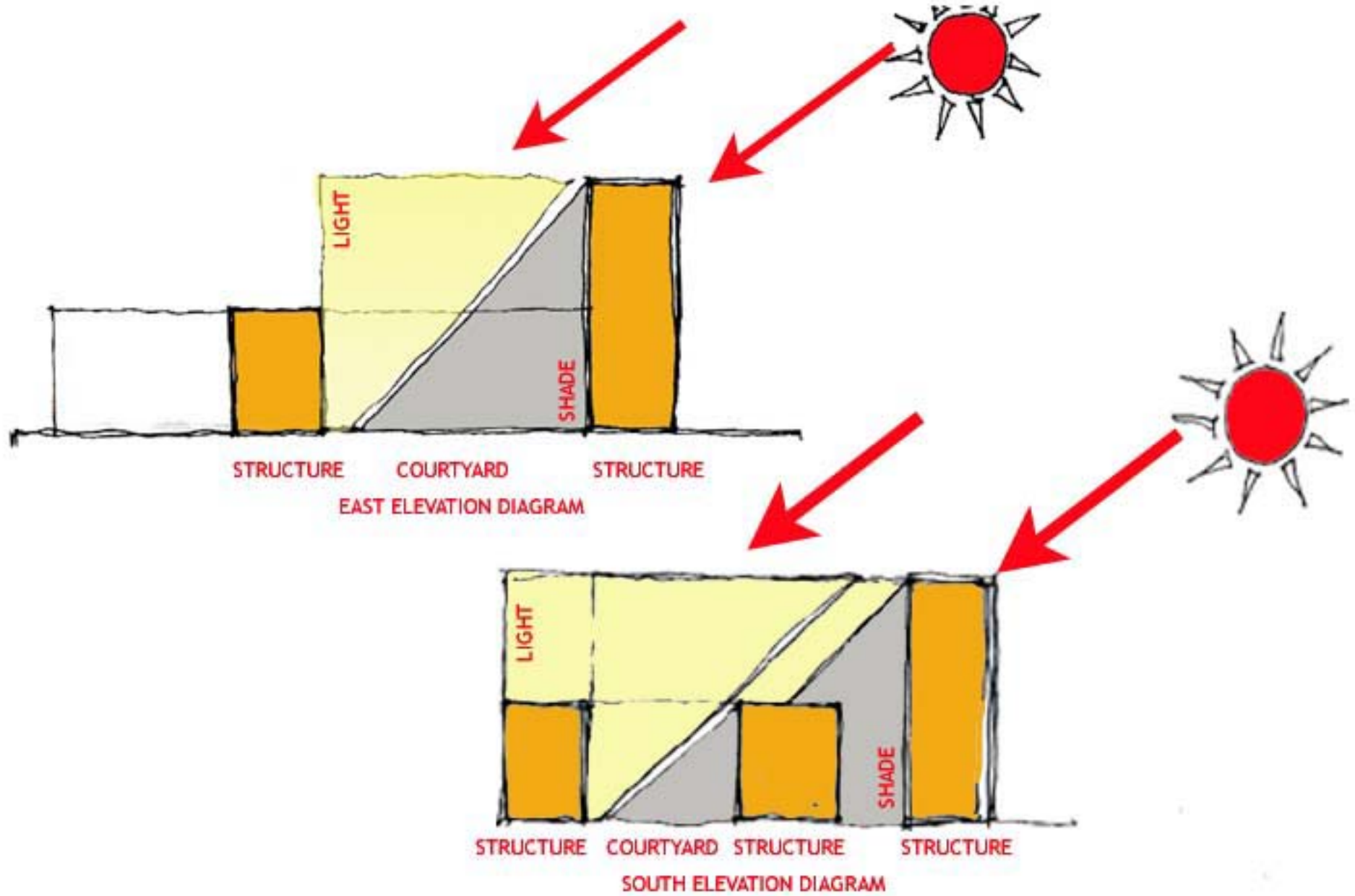

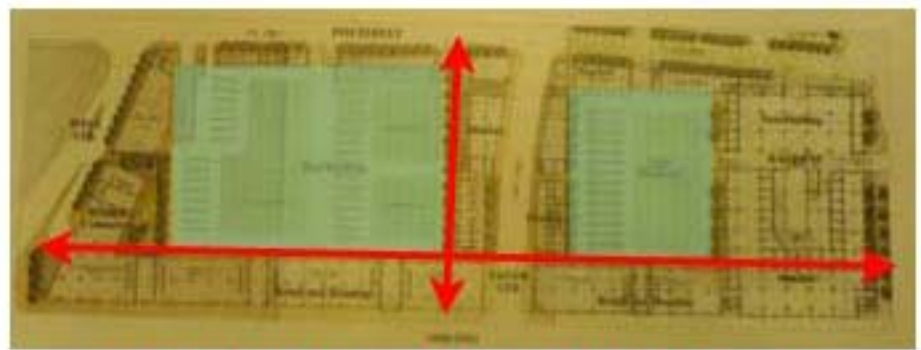

Metro mall highlighting the loading zones acting as central courts. The periphery is used as circulation space.



Tuks law building designed around two central courtyards that act as communal space. The courts are also placed adjacent to the circulation space.

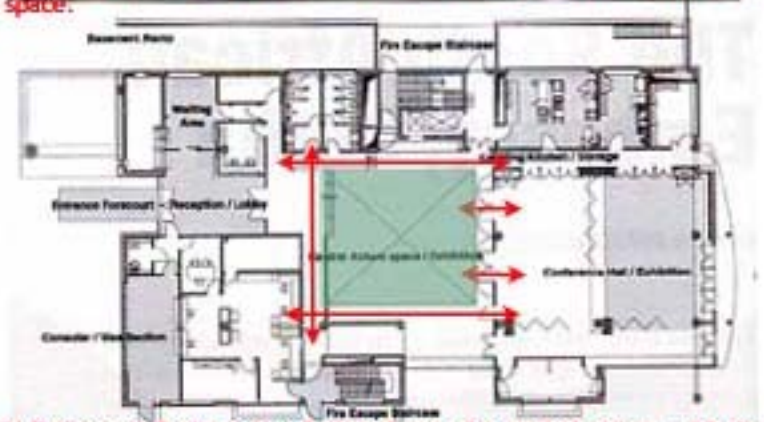

SA Embassy in Berlin is also designed around a central atrium, with the circulation space arranged on the periphery.

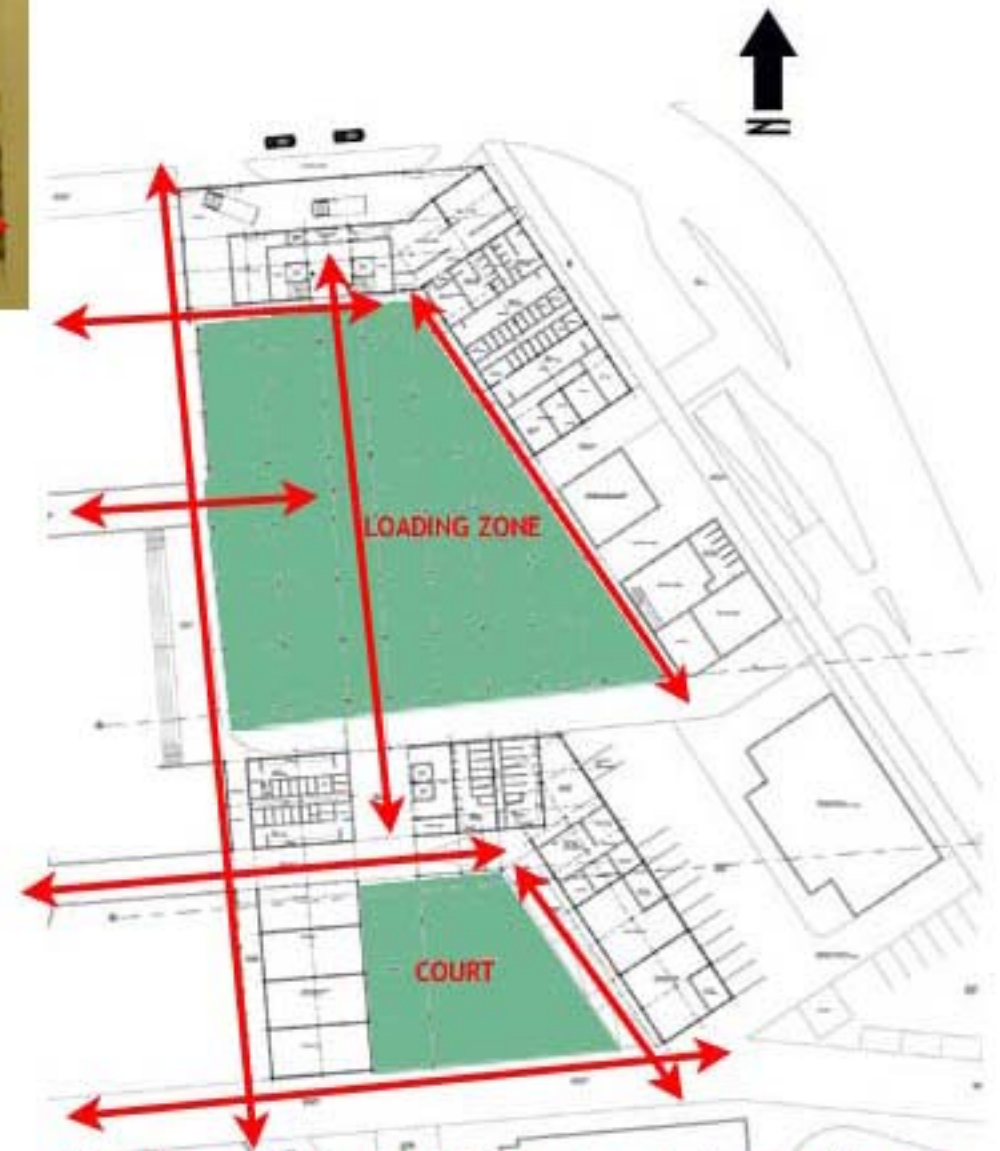

Using the courtyard as the point of departure for creating the main public spaces, with accessways directly linking the interior spaces to the courtyards.



#### VEHICULAR ACCESS

The Metro mall is designed around a simple yet effective vehicular circulation system. The busy street, (Bree street) is used as the commercial edge and taxi movement is kept completely off this edge, instead the 'backstreet' Gwingwi Mrwebi street is used for the entering and exiting of taxis.

Similarly, the station interchange adopts a system whereby Railway street is the entrance point and Scheiding street is the exit point. Traffic is directed in a one-way flow inside the loading lanes, consistently to the one-way status of both the access and exit streets.

The edge facing the square is seen as the front of the building, and is therefore used as the main commercial edge to capitalize on the high human traffic.

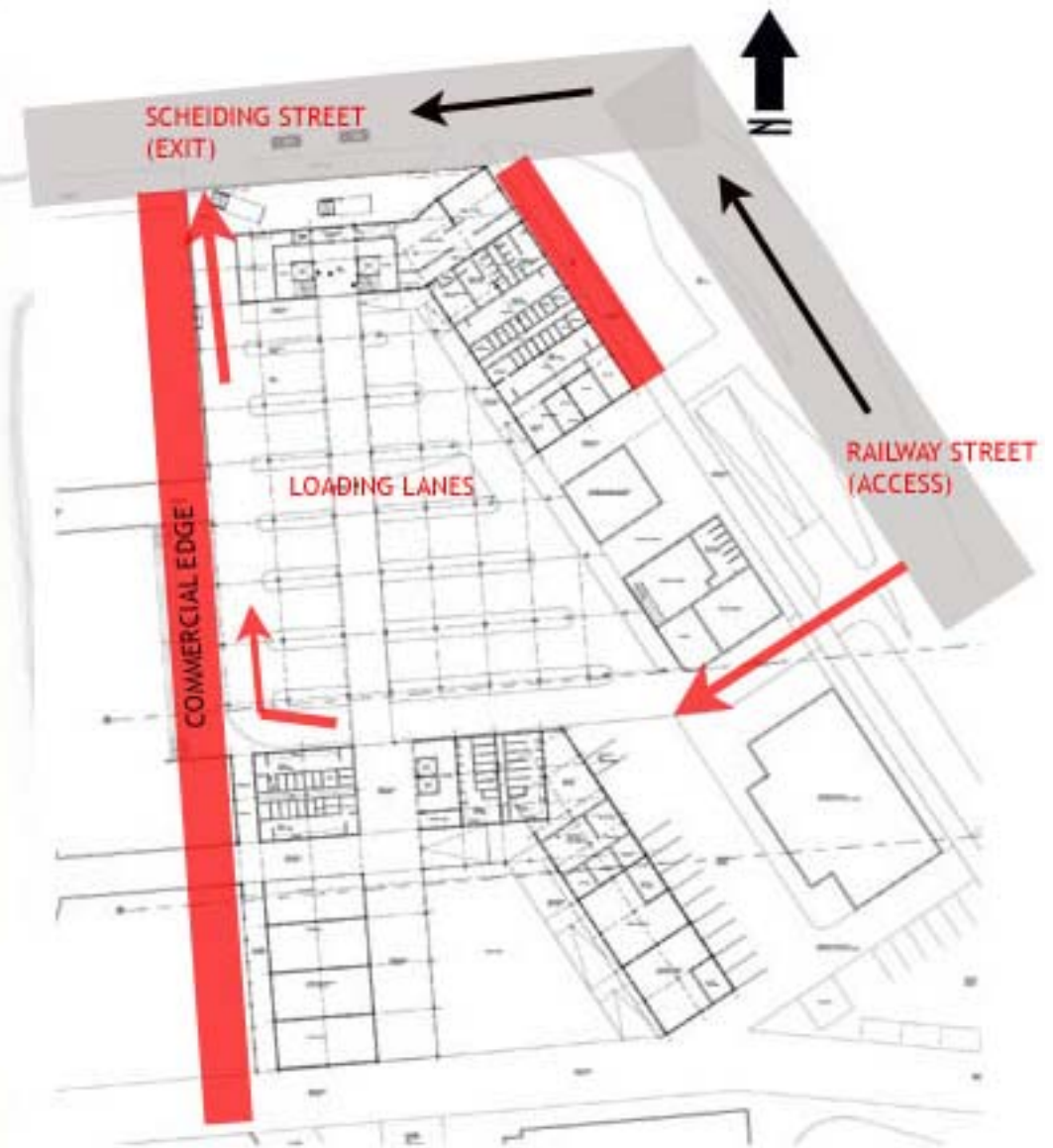







The Federation Square is laid out to accommodate 20 000 people in a square located centrally to an array of various functions such as cinemas, offices, restaurants, and art gallery. The precedent provides examples of how to create a lively civic environment. Although irregular in shape, the square remains bare in its layout to accommodate large masses. Its handling of the floor surface is austere and functional, which helps with keeping maintenance requirements low.

(www.federationsquare.com)



(www.federationsquare.com)



Vast open space



Similarly to The Federation square, Mary Fitzgerald square is designed to accommodate a large crowd of 50 000. The planning however is simple and rectilinear defined on the periphery by pedestrian walkways. The threshold between the square and the pedestrian walkways is subtly defined by carved woodwork sculptures placed on concrete bollards. The combination of street furniture and paving once again is aimed at being simple, functional yet robust.

Paving pattern/texture



Robust paving materials

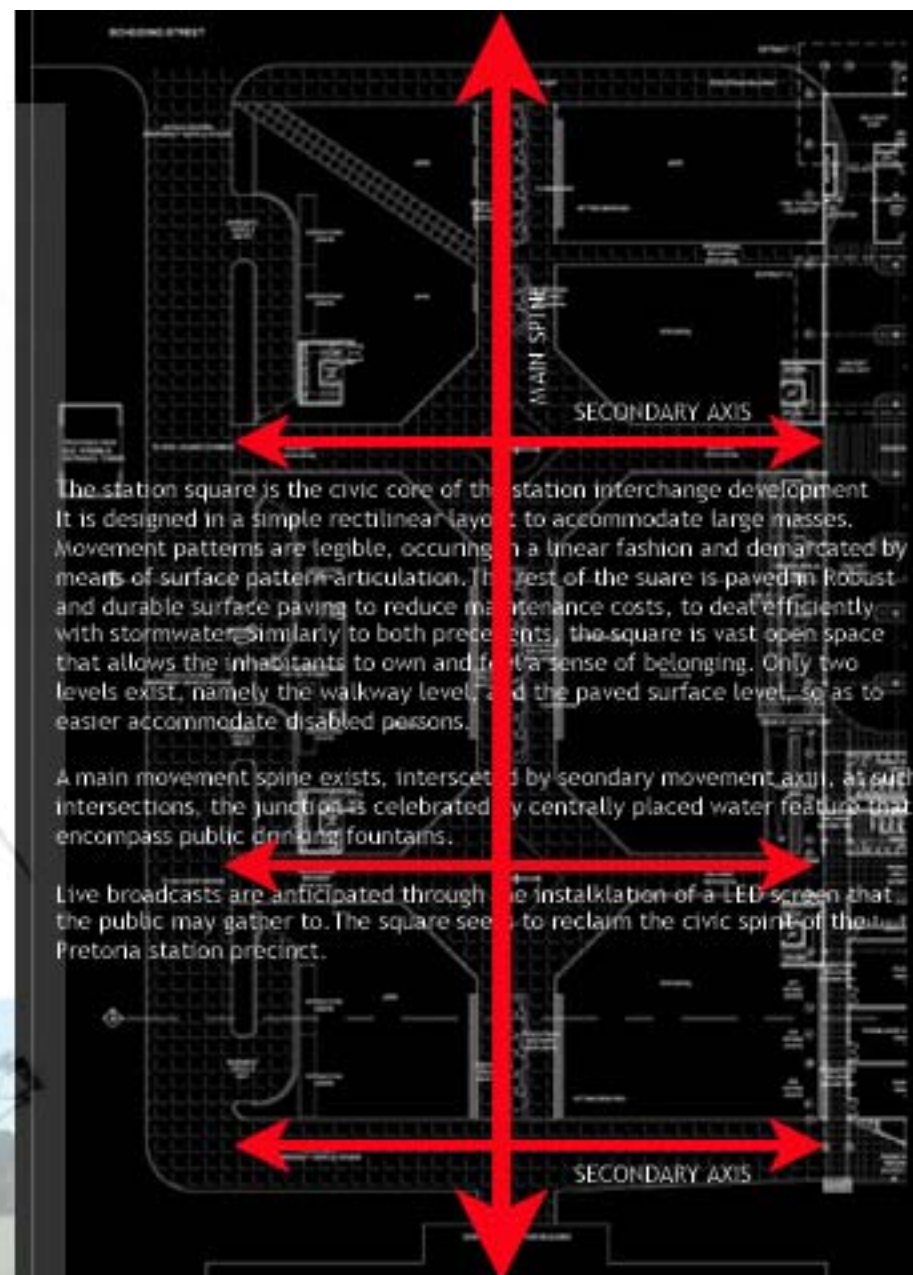

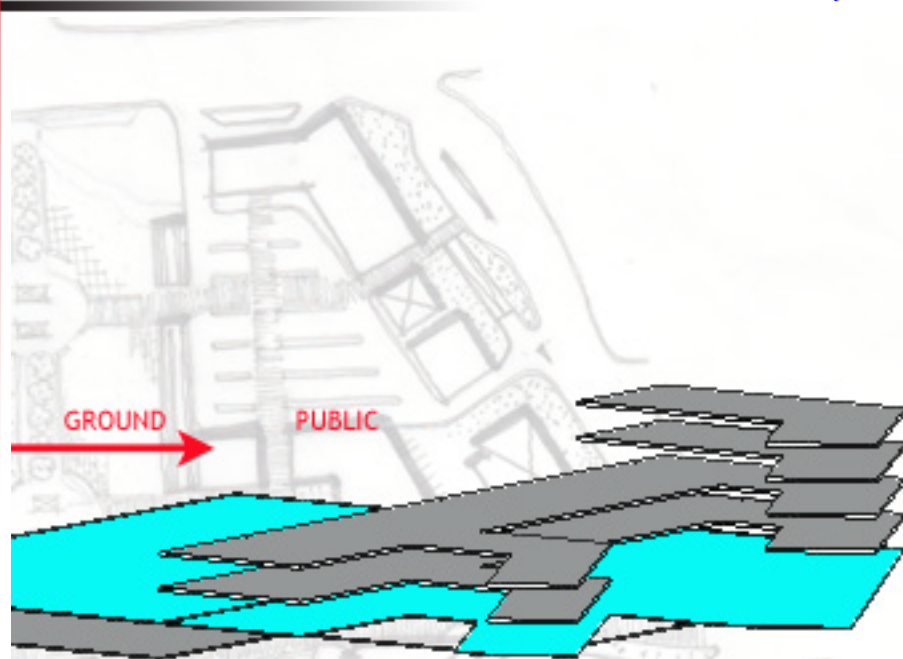

#### GROUND FLOOR

The public domain where most public traffic occurs. Retail activities, taxi rank, hawker stalls, ablutions, retail services and civic square located on this level. By virtue of its level, it is the most accessible part of the building to the public. The ground floor is openly accessible to the public thus encouraging civic activity as advocated by functionalist and humanist planning. The level at which the ground floor is open makes reference to a communal belonging and sharing in a manner that promotes the interrelation and interdependence of the various users, thus leaning towards *Ubuntu* principles.



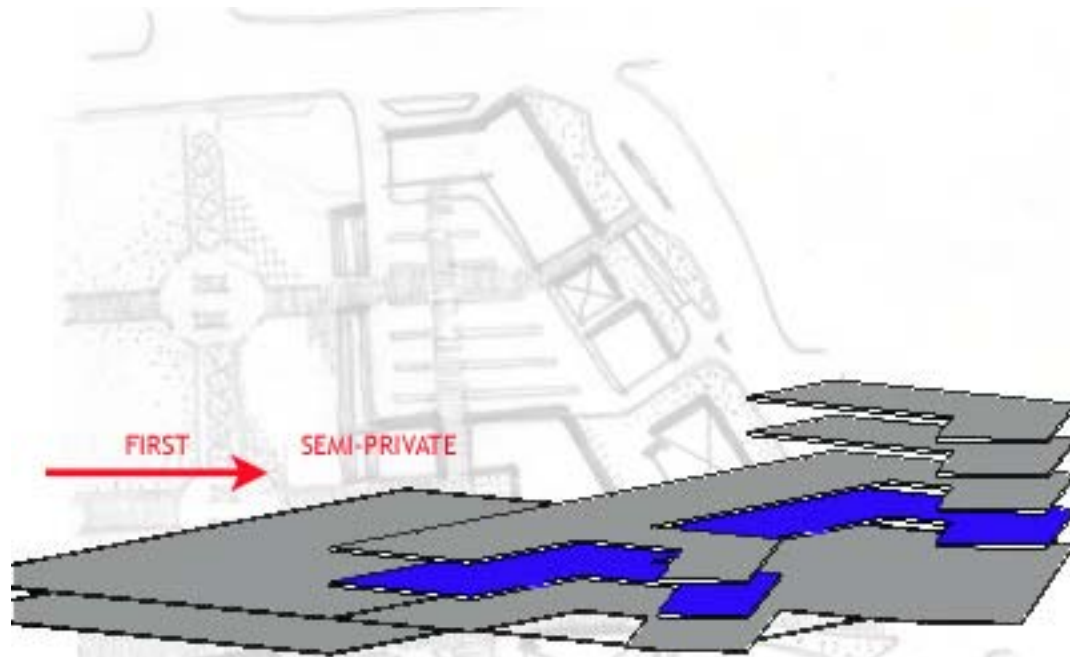

#### FIRST FLOOR

The first floor is regarded as the semi-private domain. The public activity is encouraged in the restaurant, pub, and open air gallery space.

The resource centre is also a semi private domain. Facilities available are the study area and reference books section, computer skills training centre, e-facilities centre, and a conference/meeting venue.



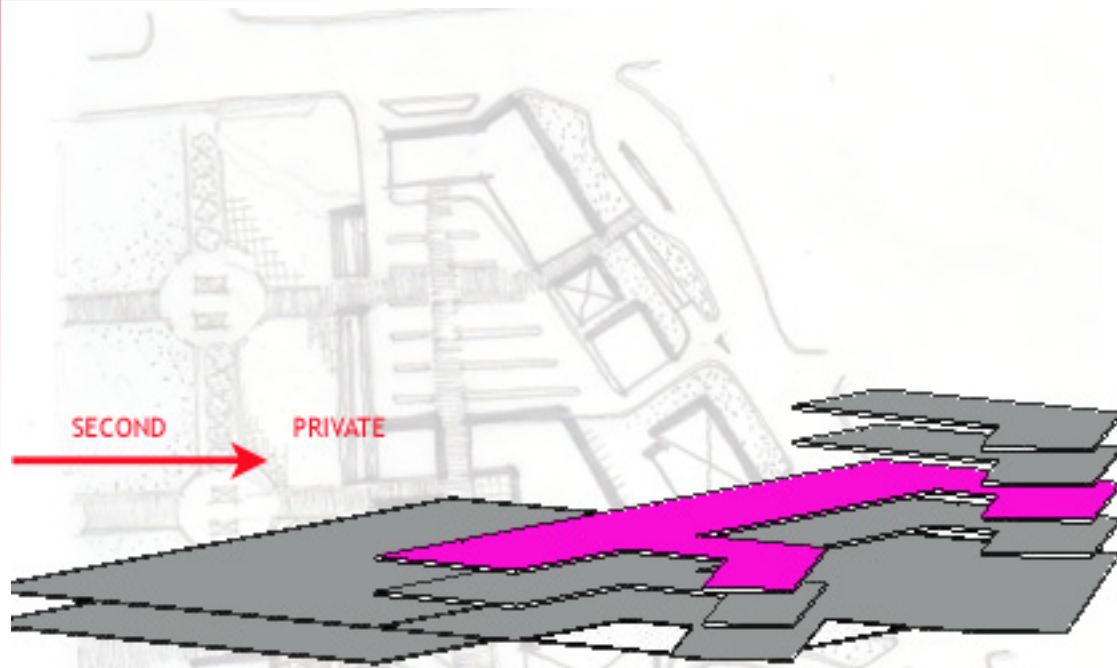

**SECOND FLOOR**

This level is reserved for office space, and is regarded as private domain. The general public is restricted unless visiting by necessity.



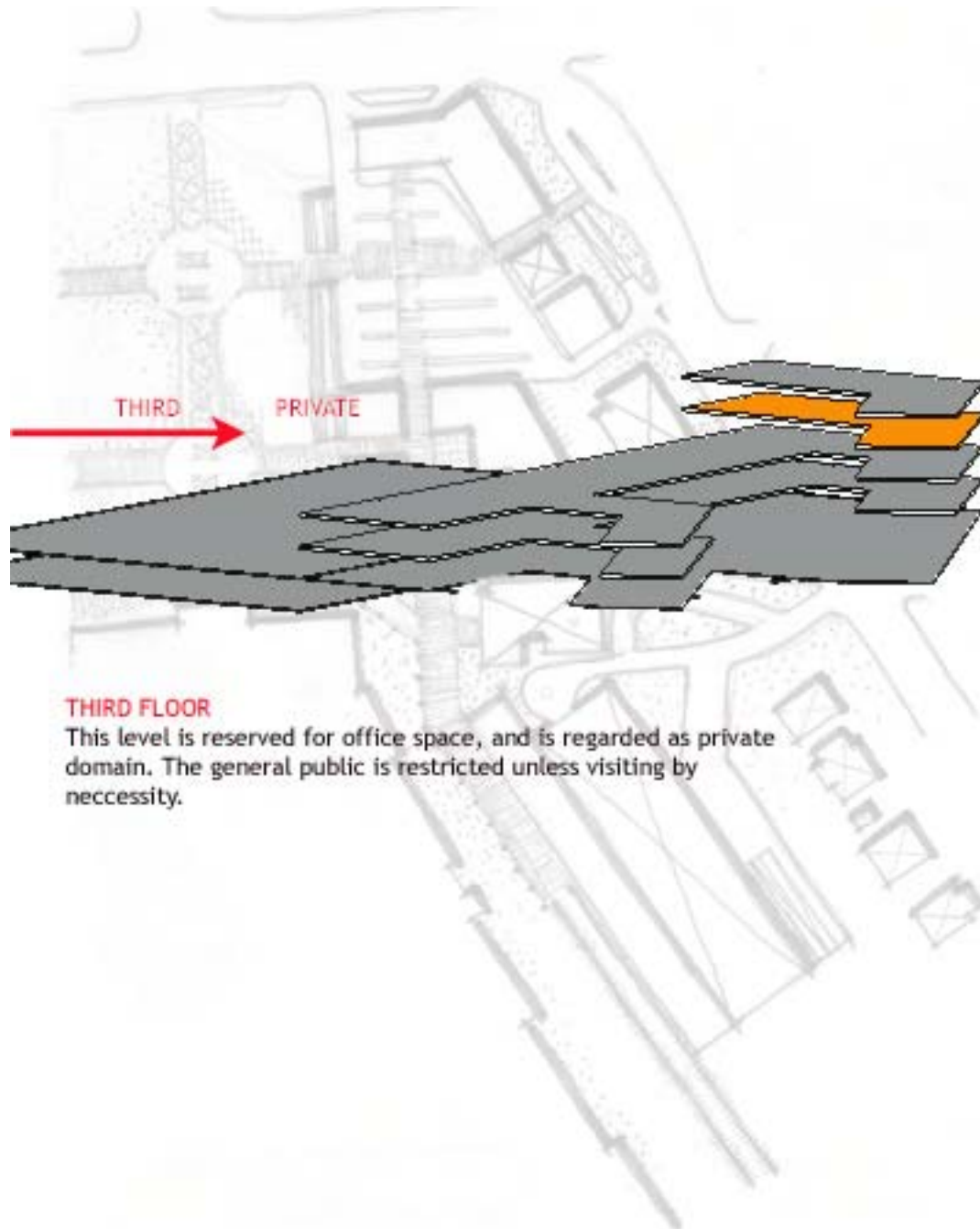

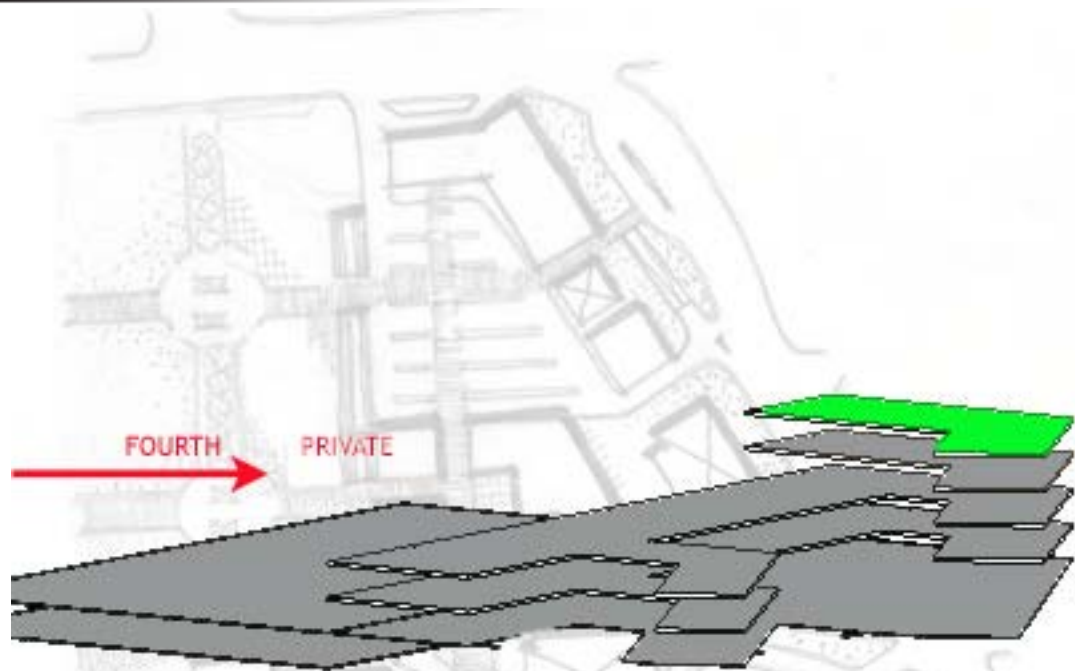

**FOURTH FLOOR**

This level is reserved for office space, and is regarded as private domain. The general public is restricted unless visiting by necessity.





The station interchange thresholds are the points from which the commuters, workers, and visitors get their first impression of the place. Here it is important to articulate the entry points that demarcate the inside and outside of the development. However, since the station is a public place, such entrances need to be subtle yet visually appealing and also offer orientation.

The choice of materials is stone and concrete, in order to achieve a striking, almost monumental effect, yet retaining a modern feel.

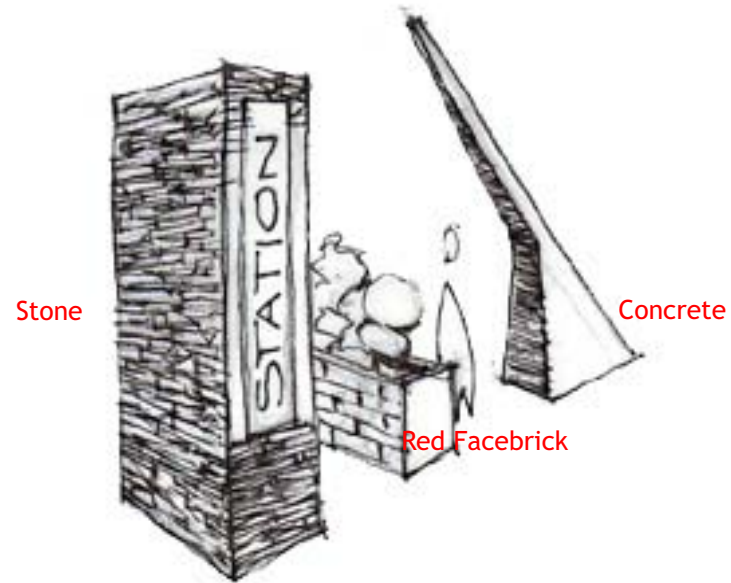

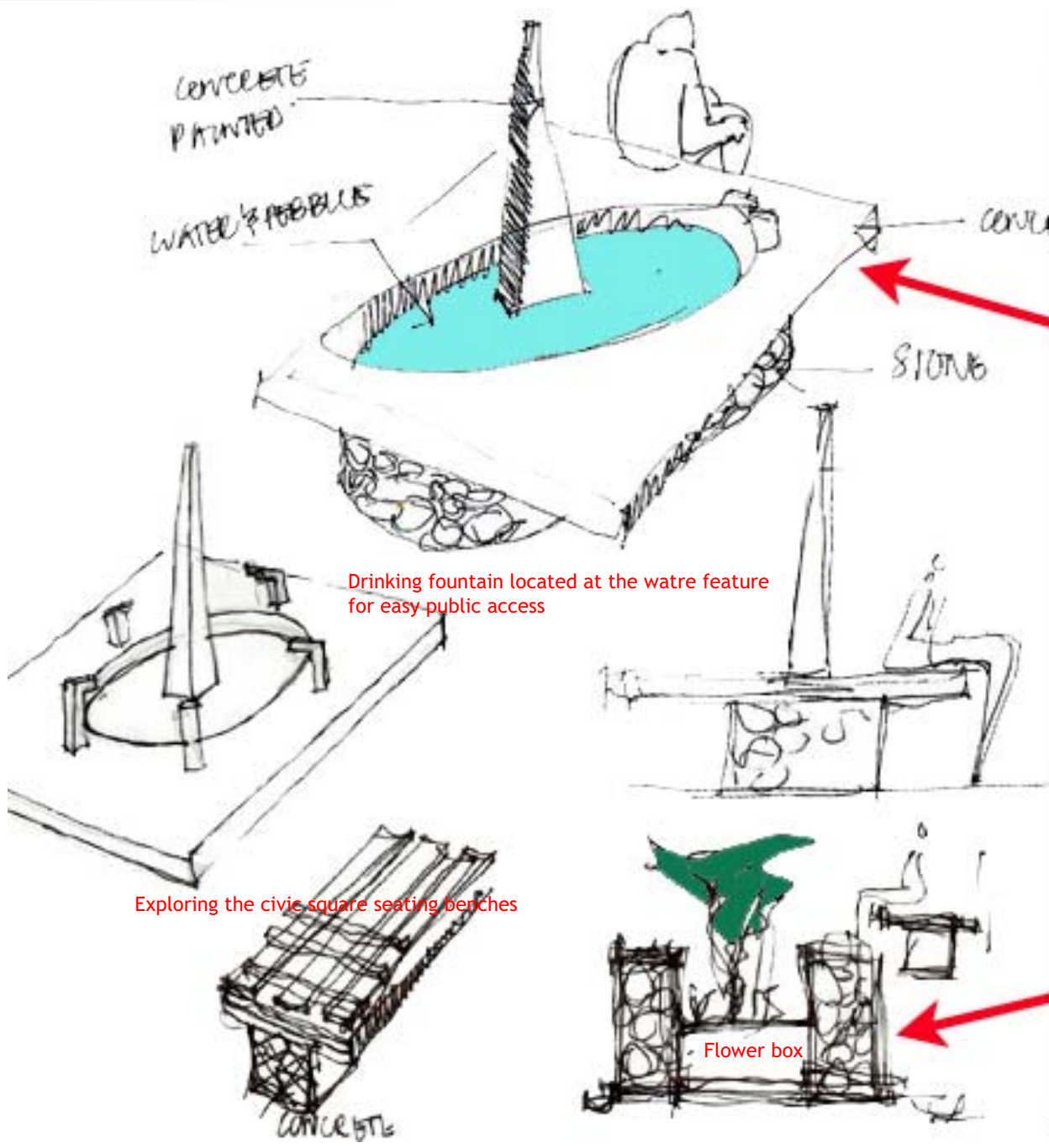





(Hoiting and Boer 2000:74)



Screen mesh cladding

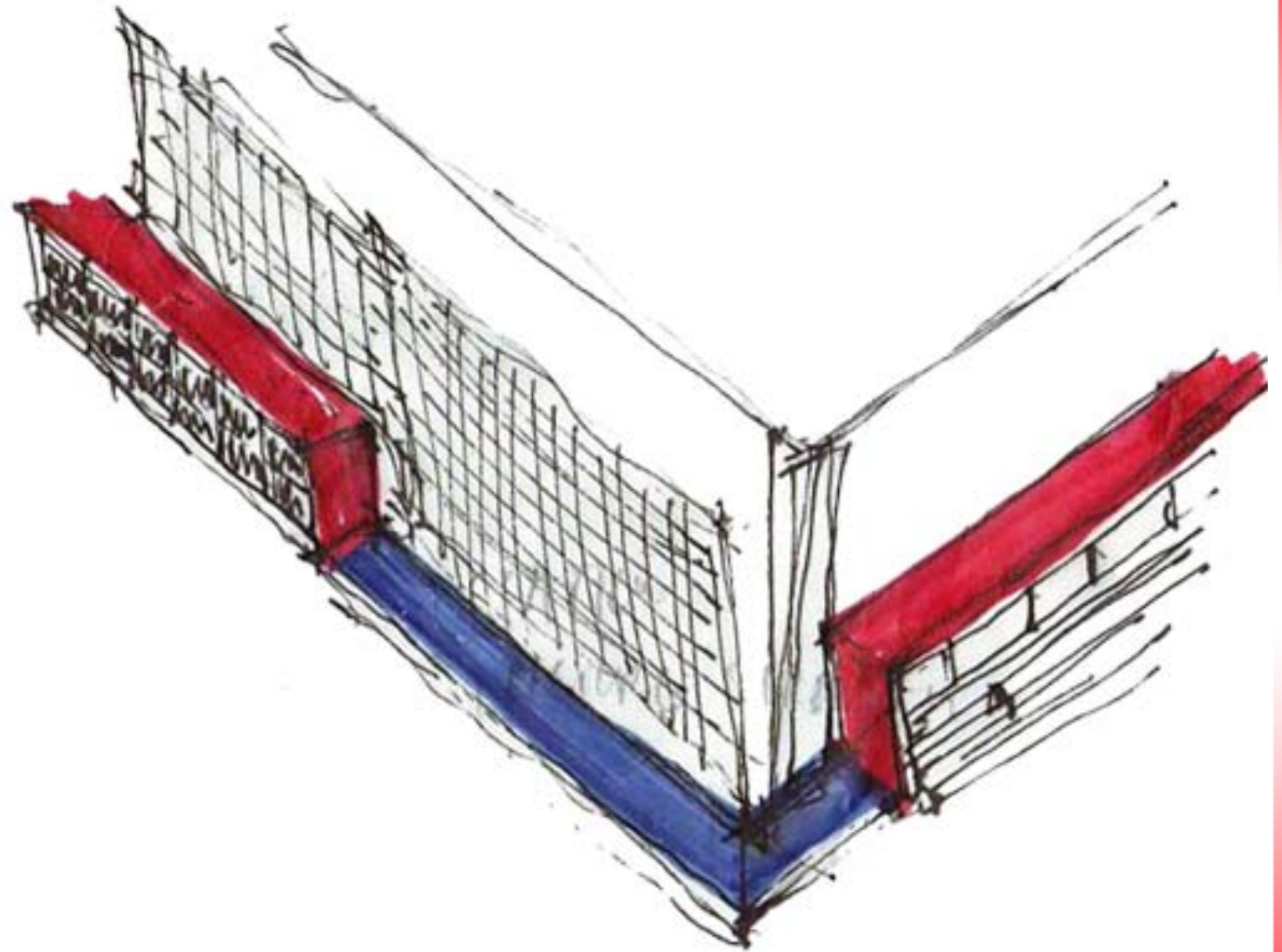

Exploring how screens can be both functional and aesthetic on the facades. The introduction of brightly coloured concrete elements assist in creating a lively experience.

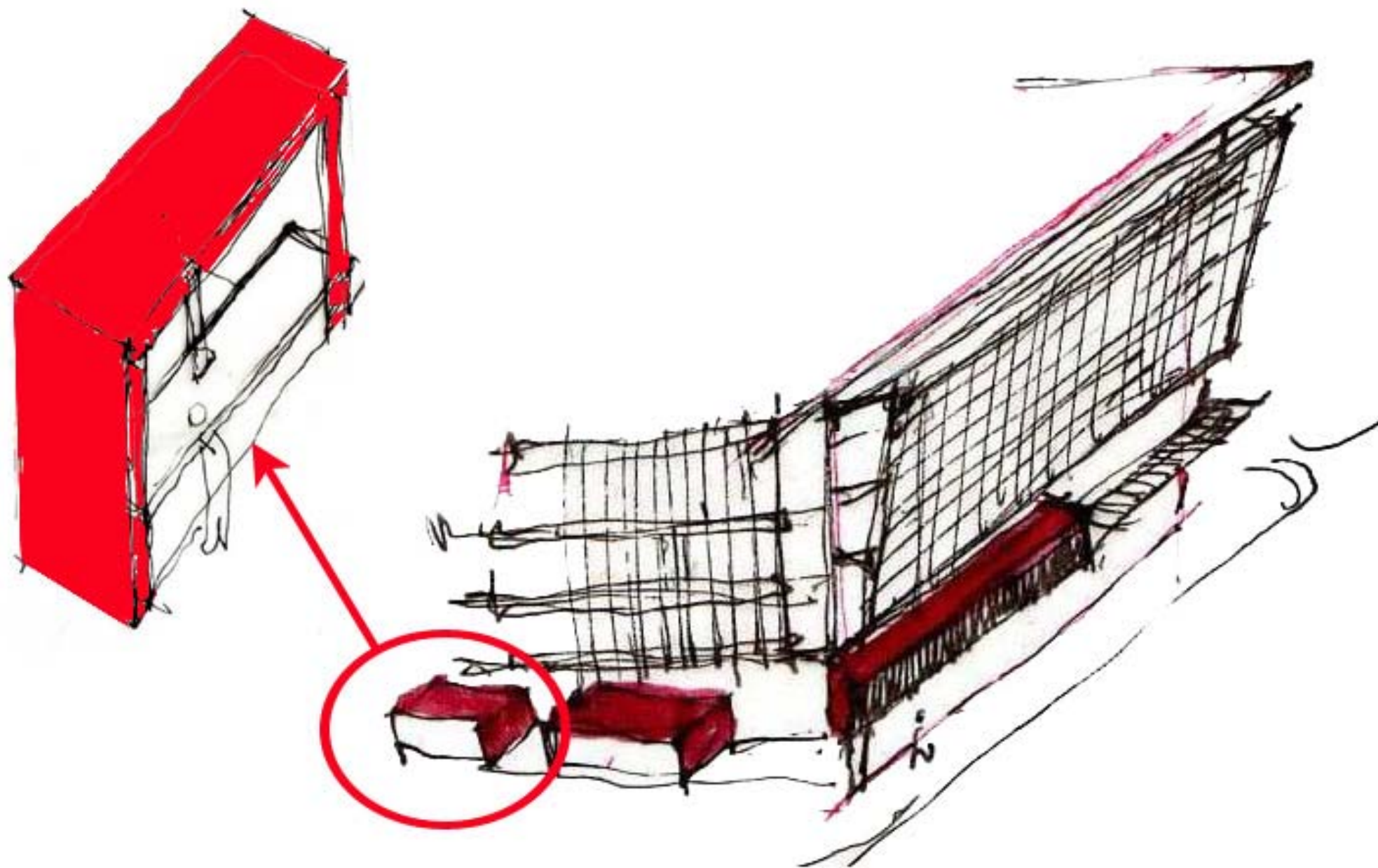

The commercial edge is articulated by means of brightly coloured box-shaped hawker stalls. These attract the passer-by's attention and add character to the facade.

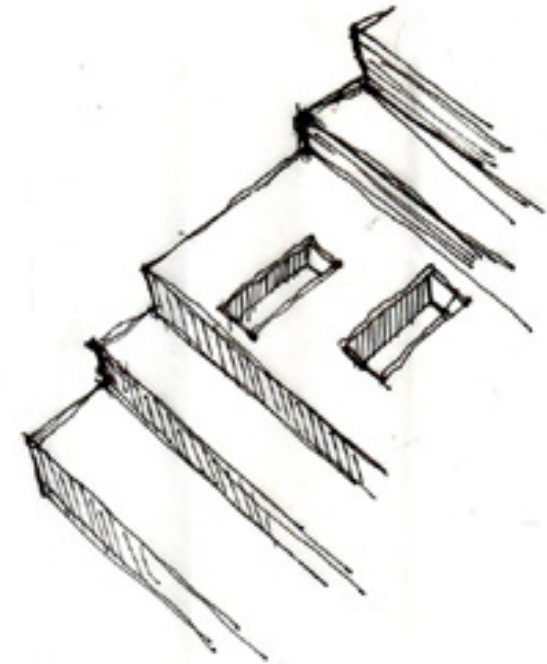
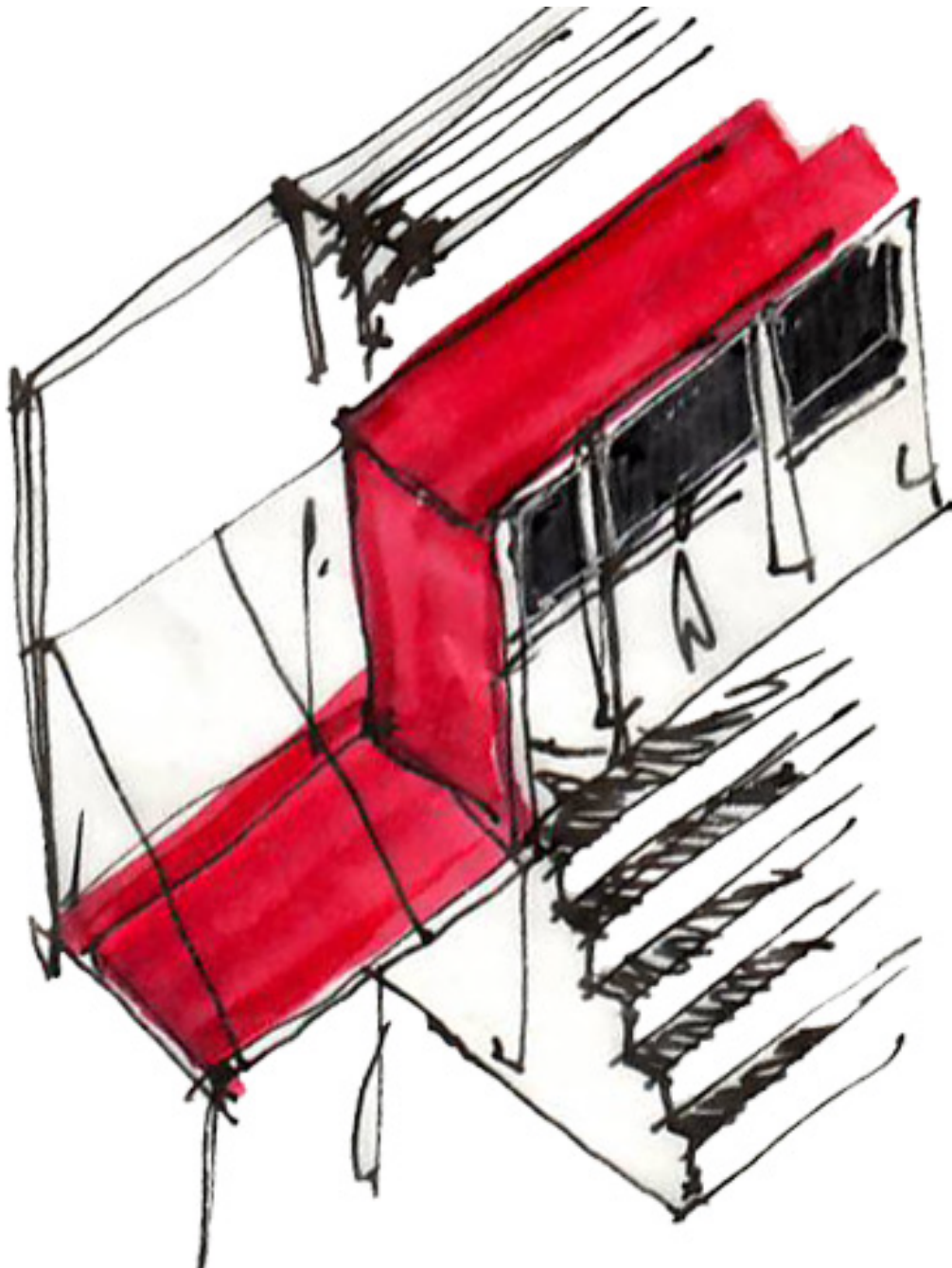

Means of creating seating overlooking the civic square, by creating deep riser and wide tread stairs. The underside of these stairs become hawker stalls facing the taxi rank. Ideas of allowing light to penetrate into the taxi rank area are explored

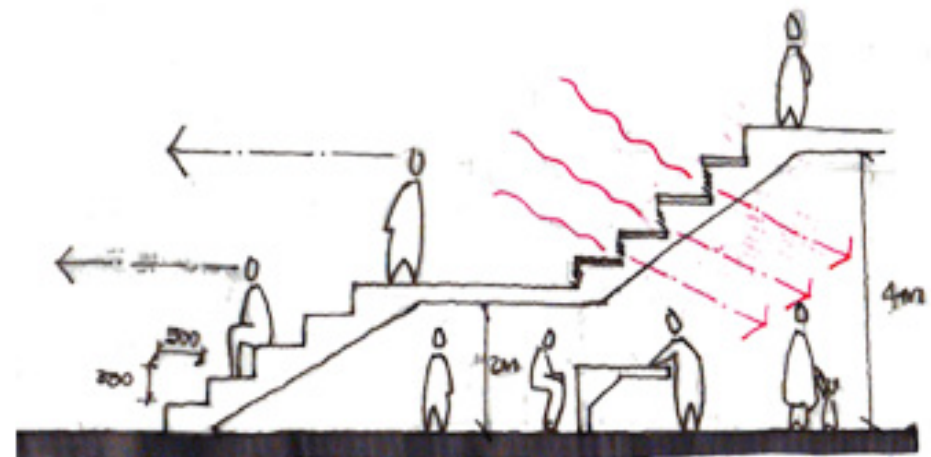



Dealing with the junction of the old and the new, looking at how to play with colour and texture in order to visually merge the two.

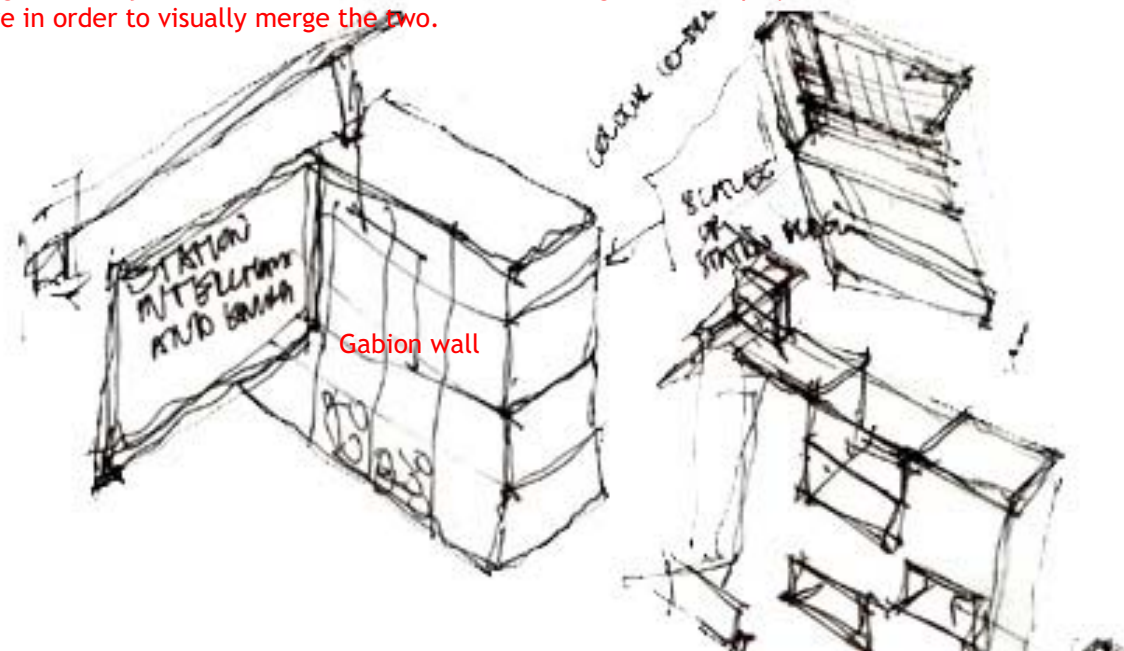
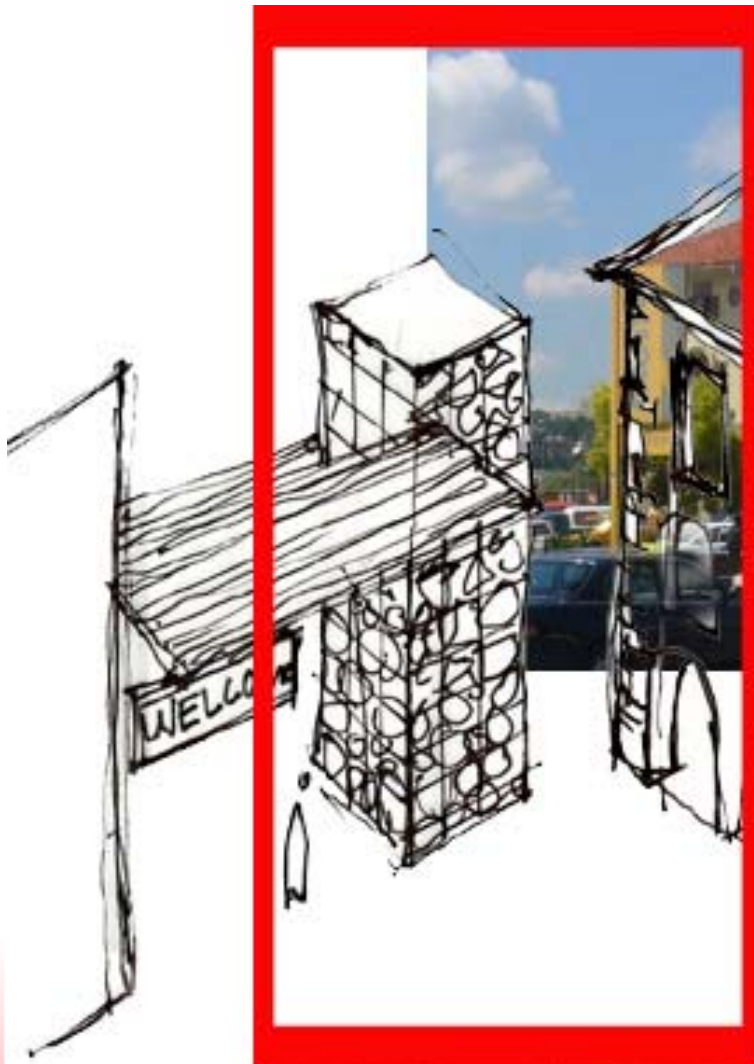

Roof technology exploration

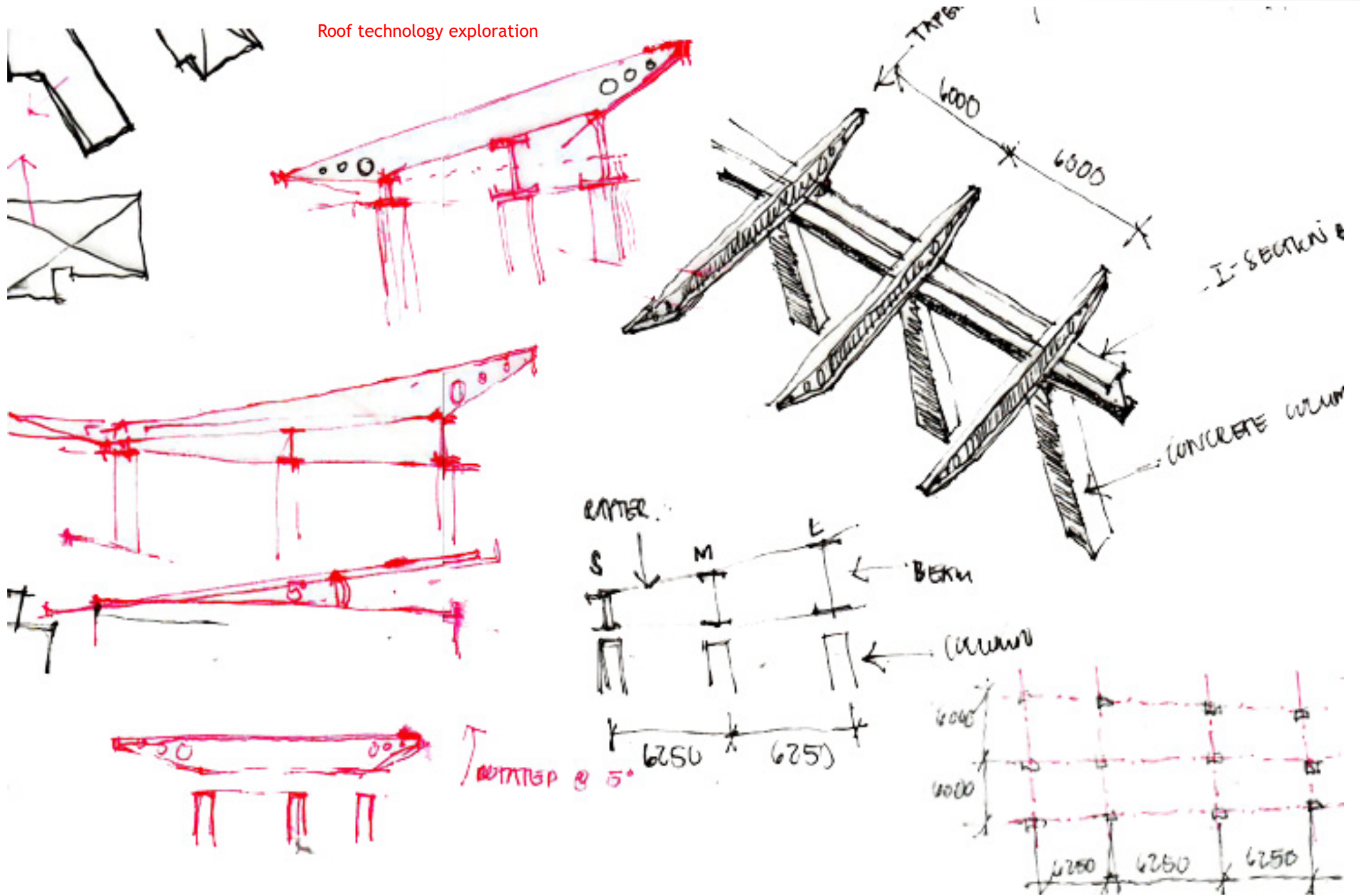

Ideas for covered walkway roofs

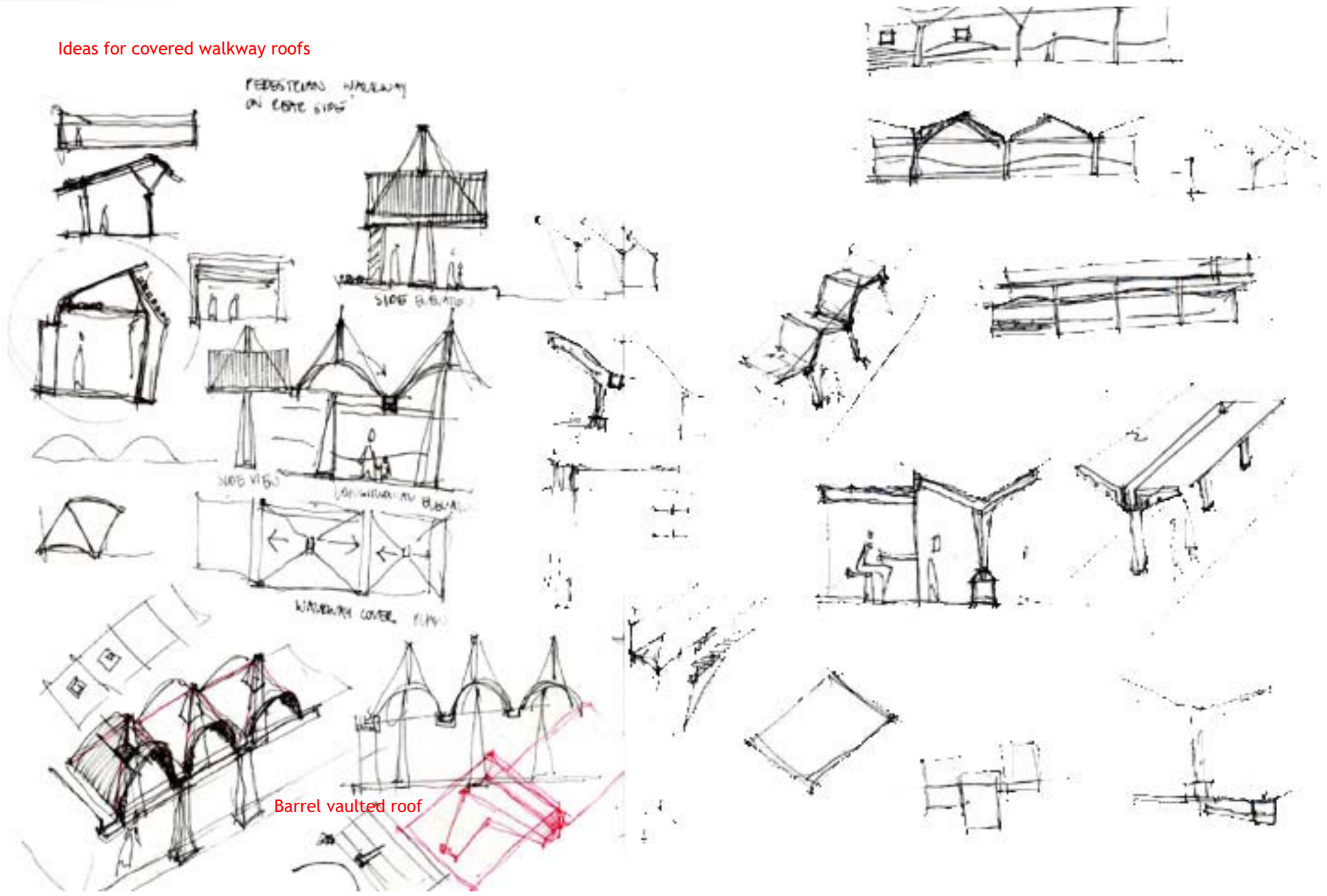

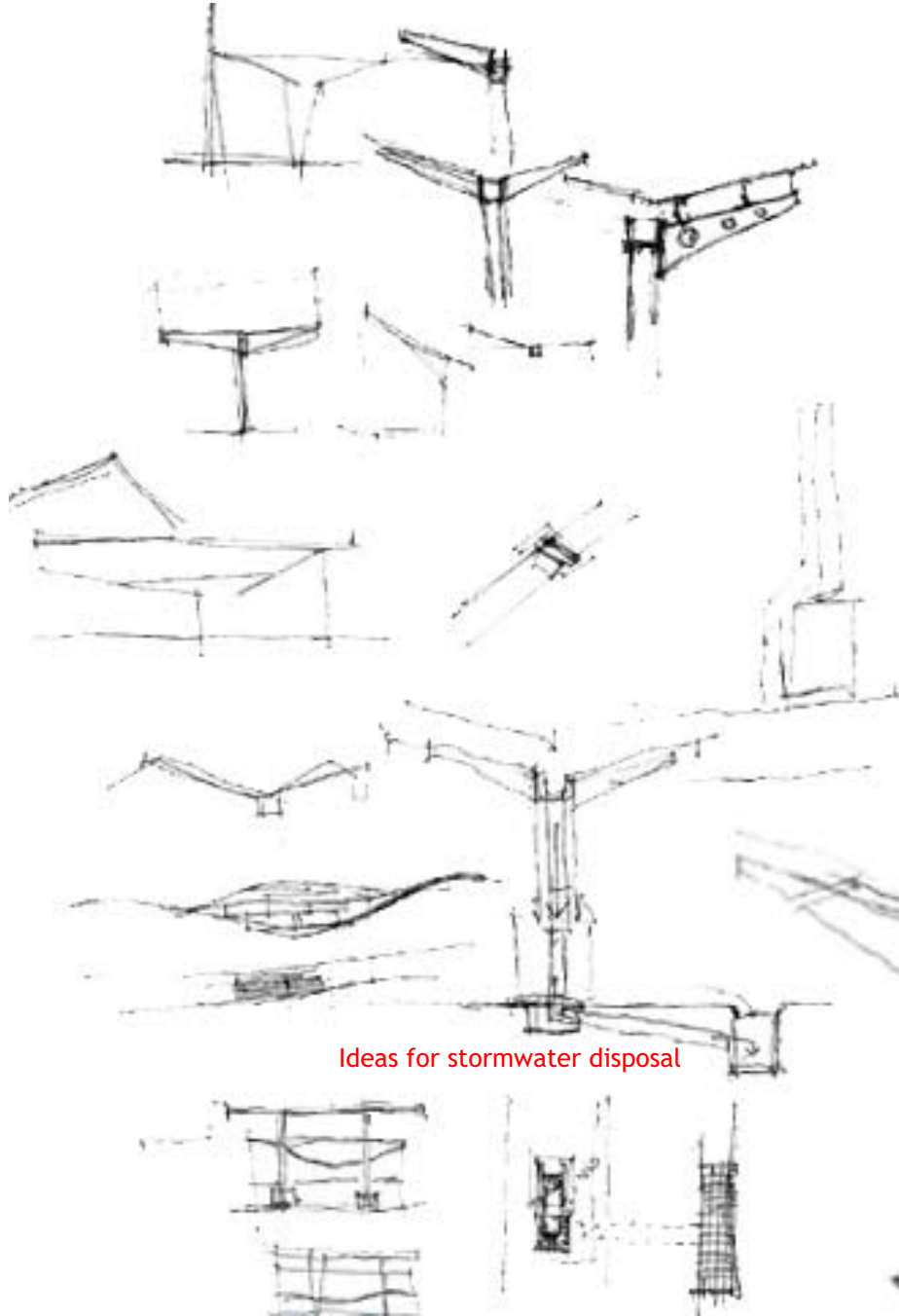

Ideas for stormwater disposal

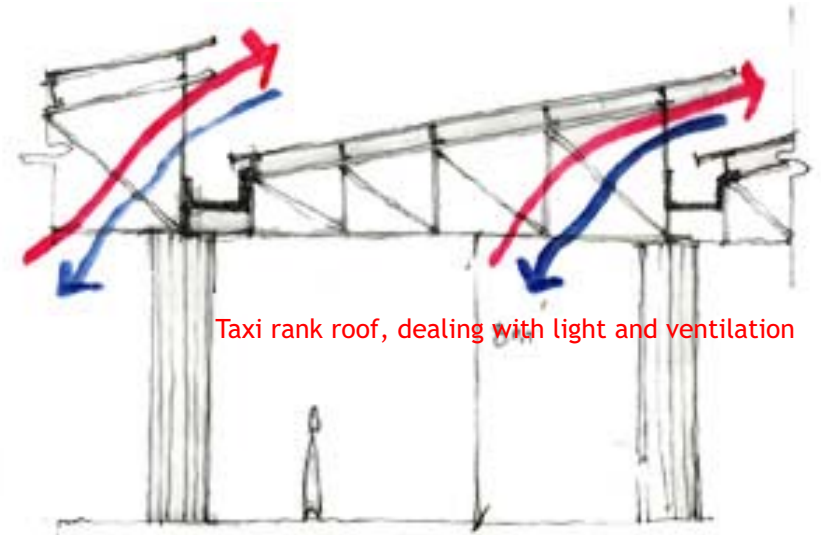

Taxi rank roof, dealing with light and ventilation



Covered walkway screen wall ideas

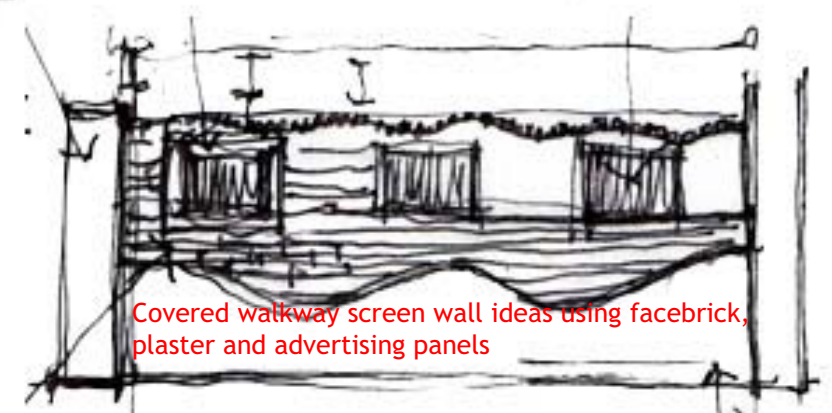

Covered walkway screen wall ideas using facebrick, plaster and advertising panels

Elements of the tree shape begin to surface

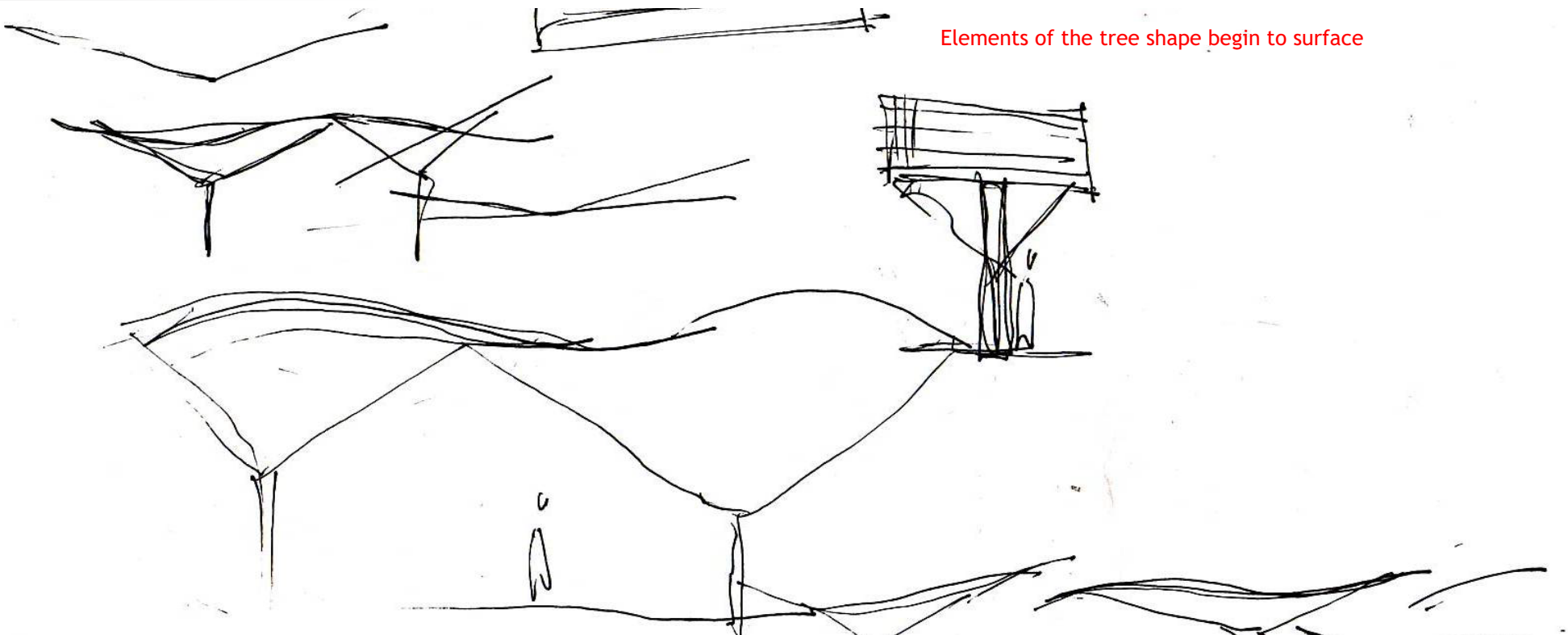

Continued exploration of roof covering profile

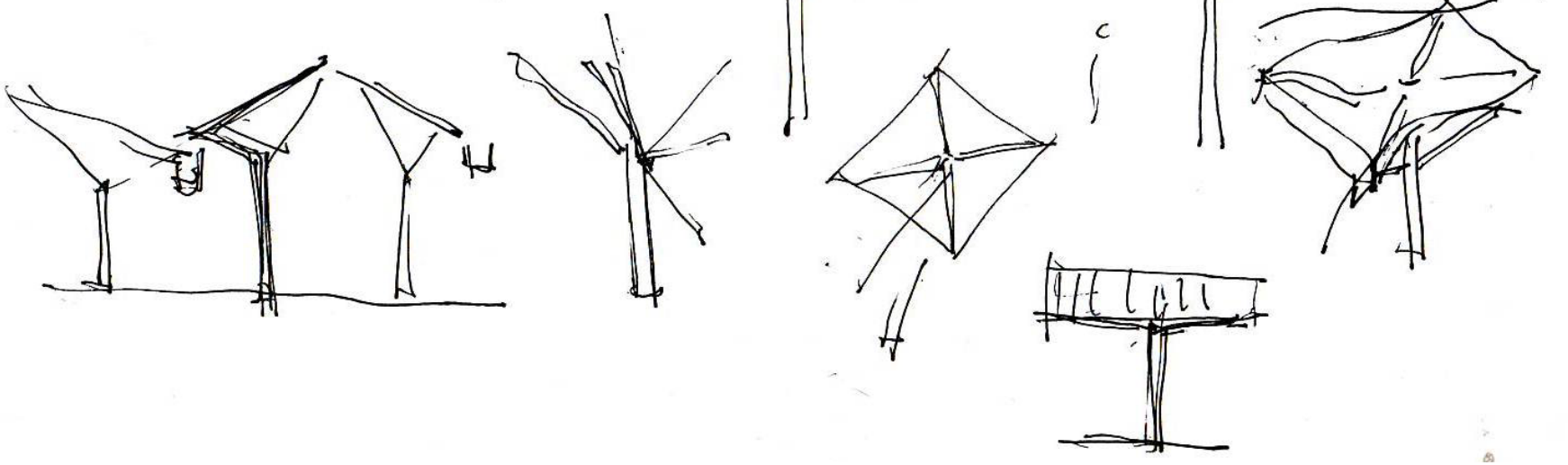



Development and refinement of the tree shape begin to surface

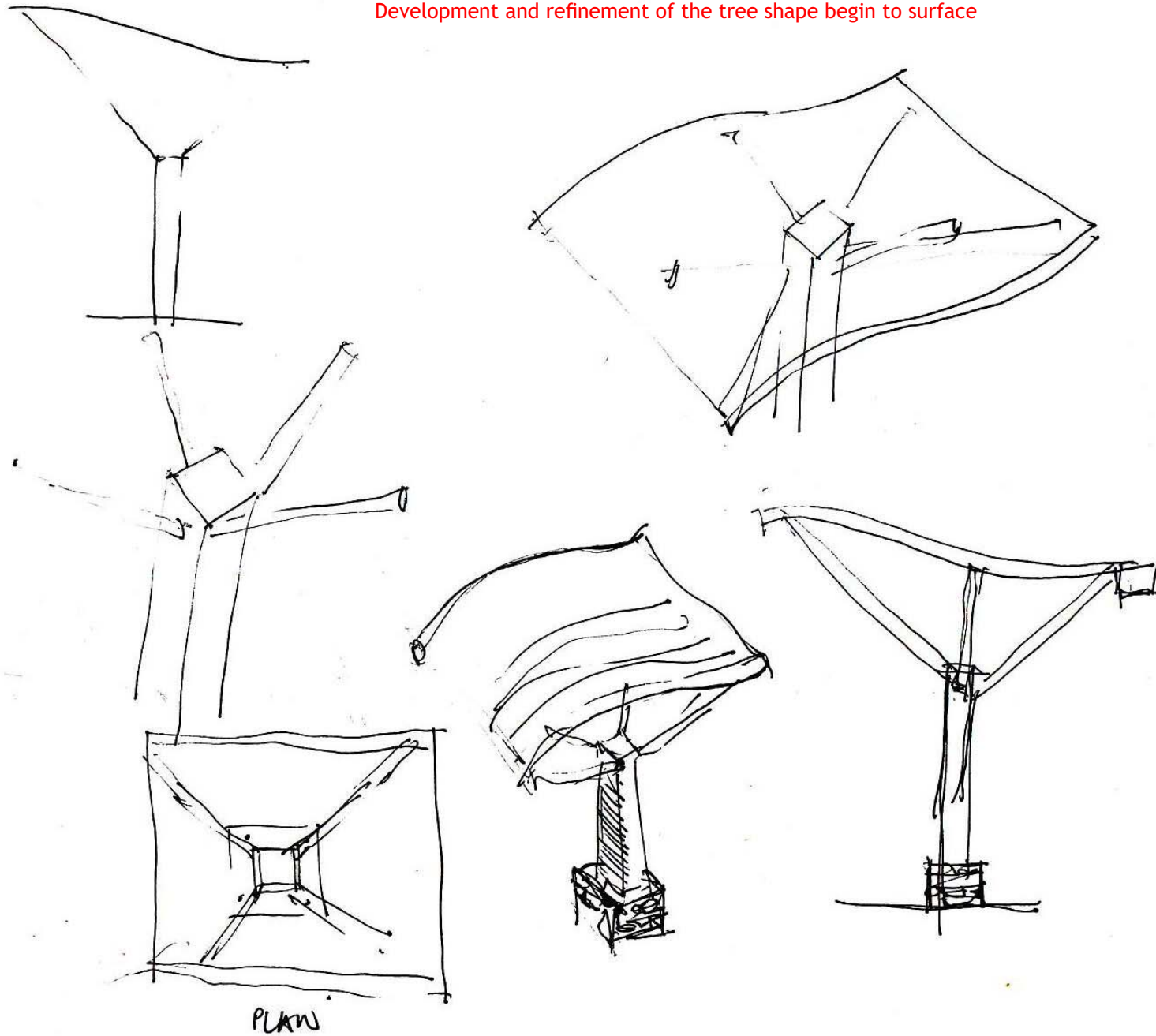

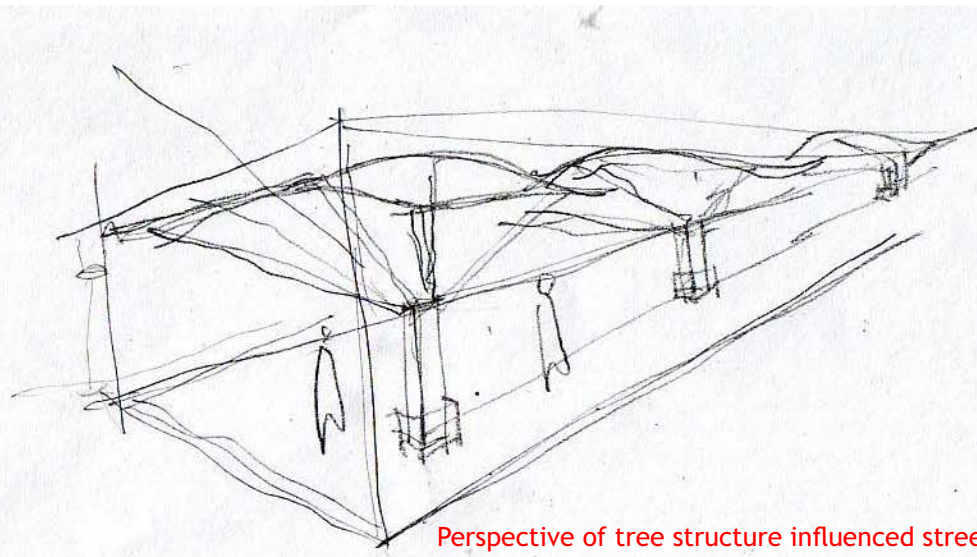

Perspective of tree structure influenced street walkway roof covering

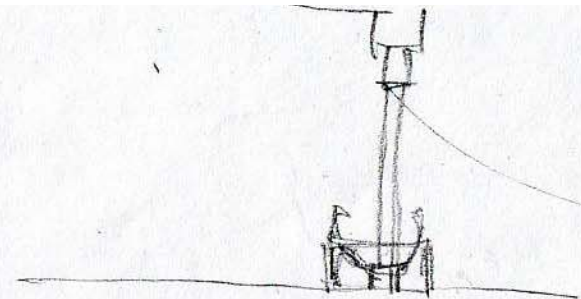

Stormwater treatment

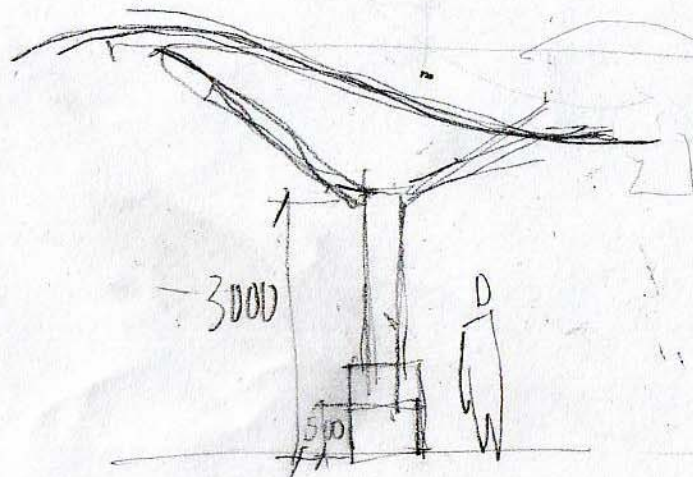

Side profile walkway sketch

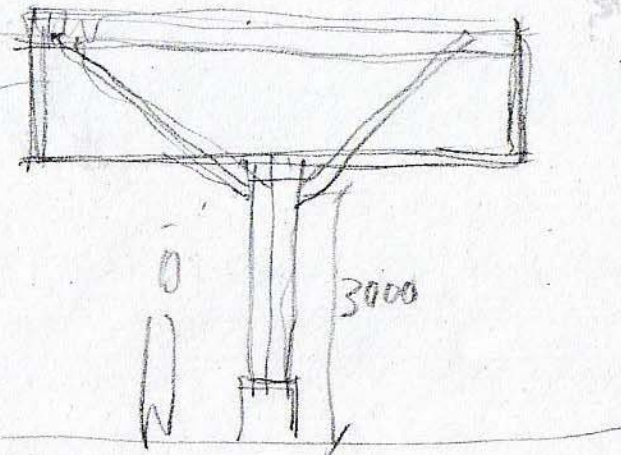

Cross section of tree structure walkway

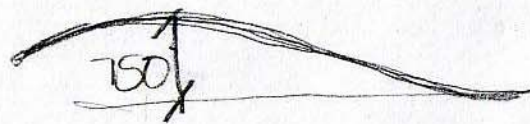

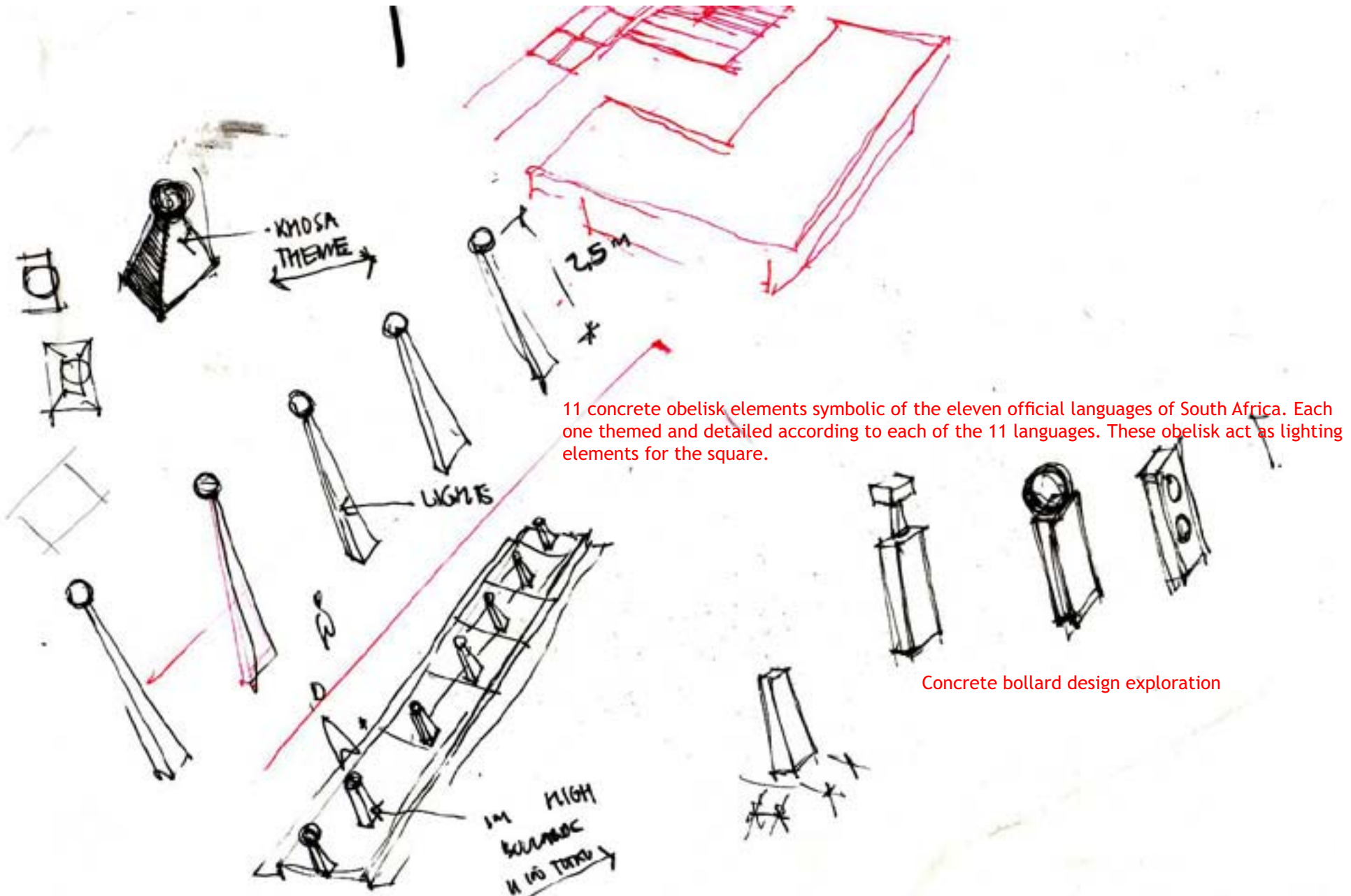

11 concrete obelisk elements symbolic of the eleven official languages of South Africa. Each one themed and detailed according to each of the 11 languages. These obelisk act as lighting elements for the square.

Concrete bollard to demarcate the boundary of the square, while offering a visually aesthetic means of enclosure

Exploration of solar protection on the north facade

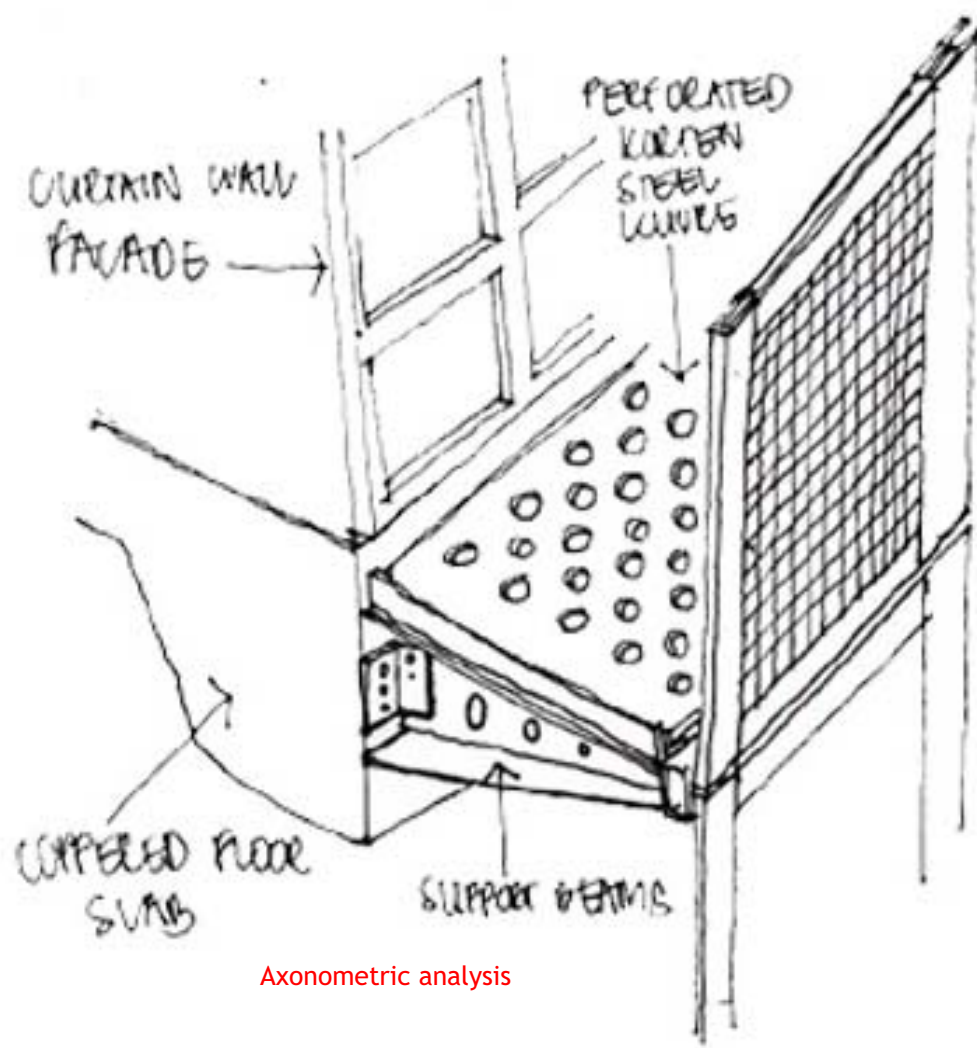

Axonometric analysis

STAINLESS STEEL FINE GRIDDED MESH IN A STEEL FRAME.

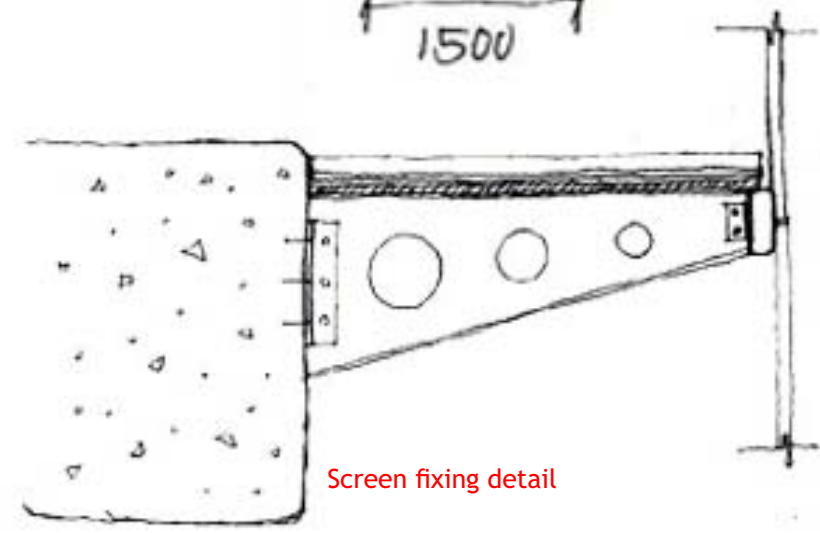
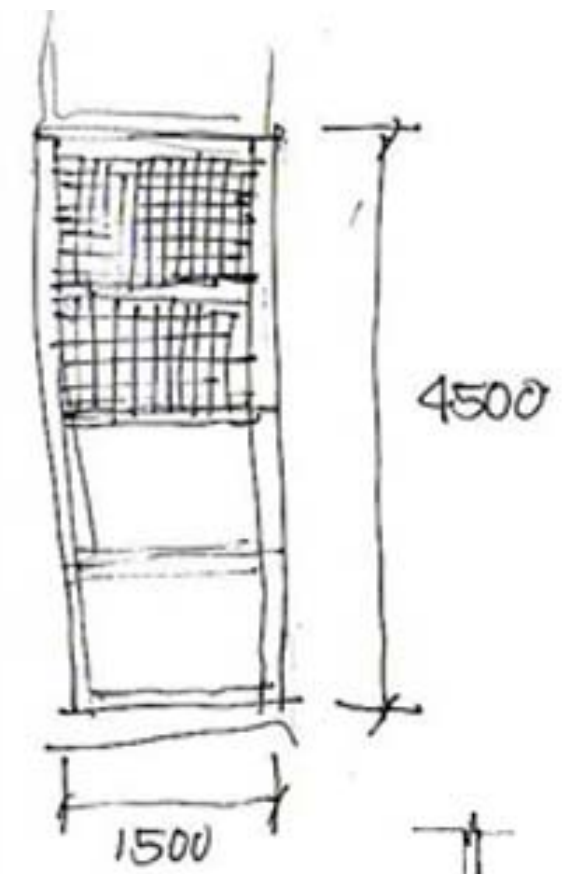

Screen fixing detail

Exploration of solar protection on the east and west facades

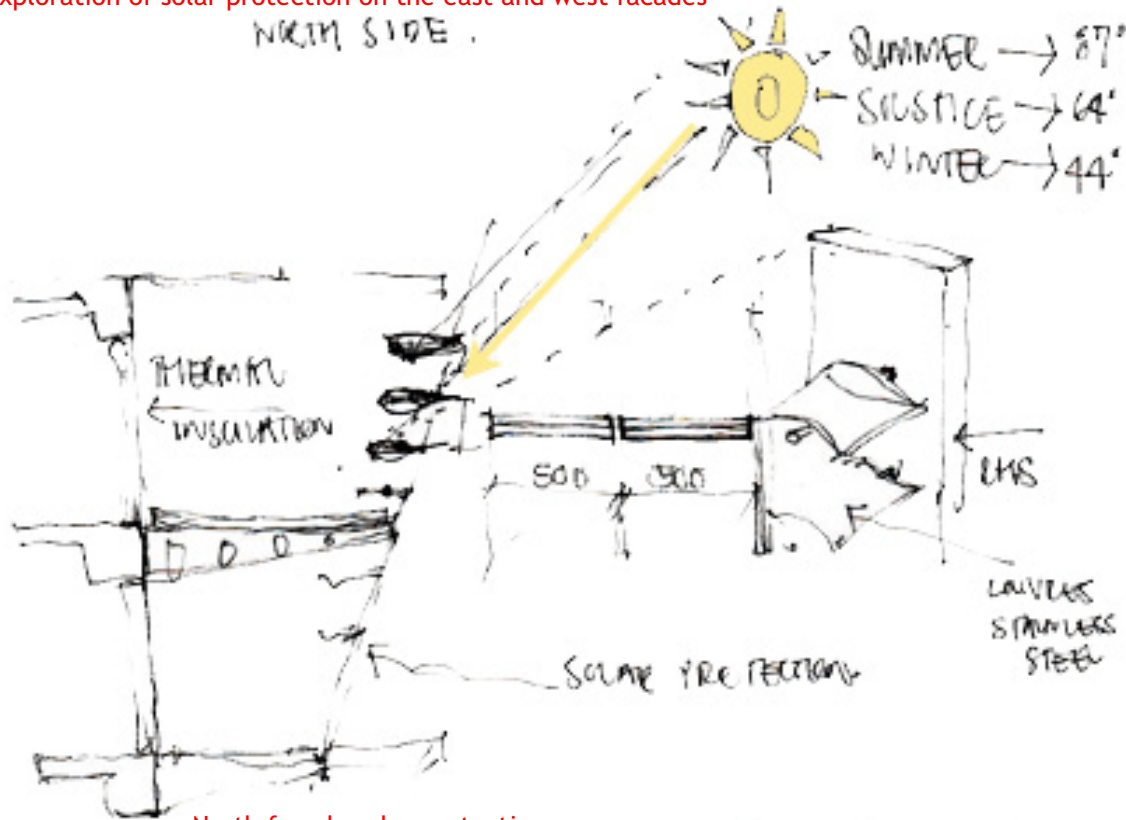

North facade solar protection

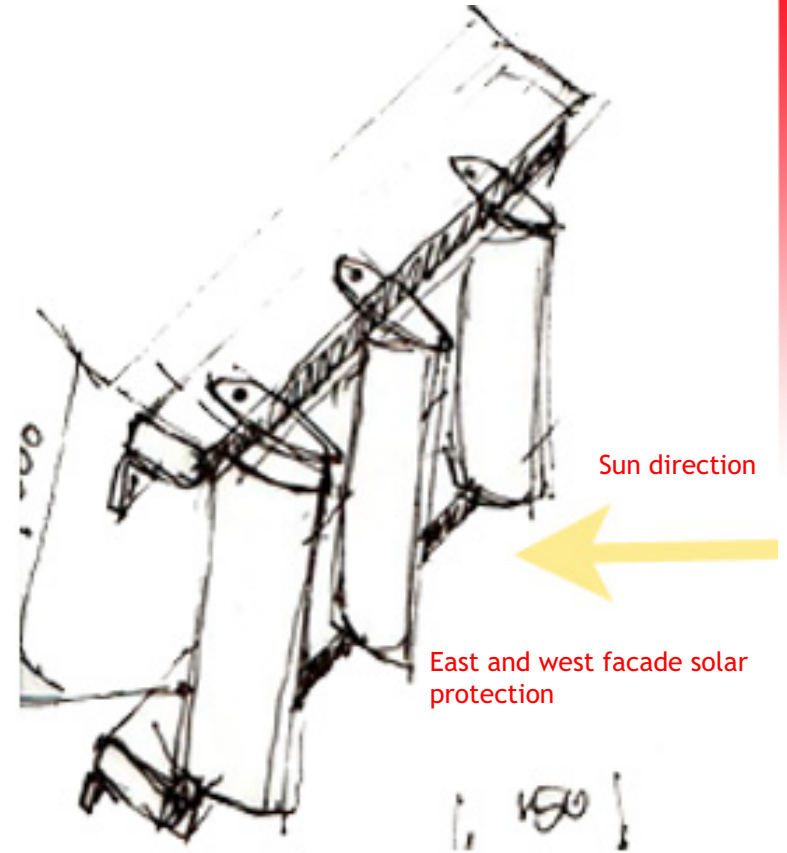

East and west facade solar protection

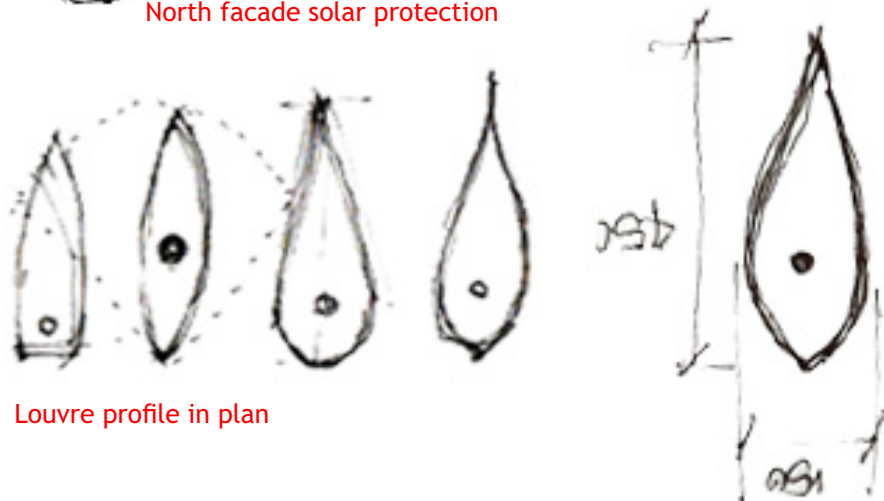

Louvre profile in plan

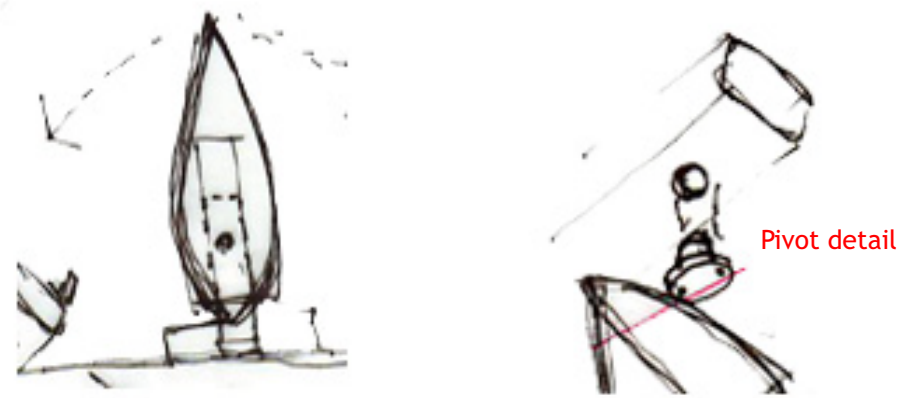

Pivot detail

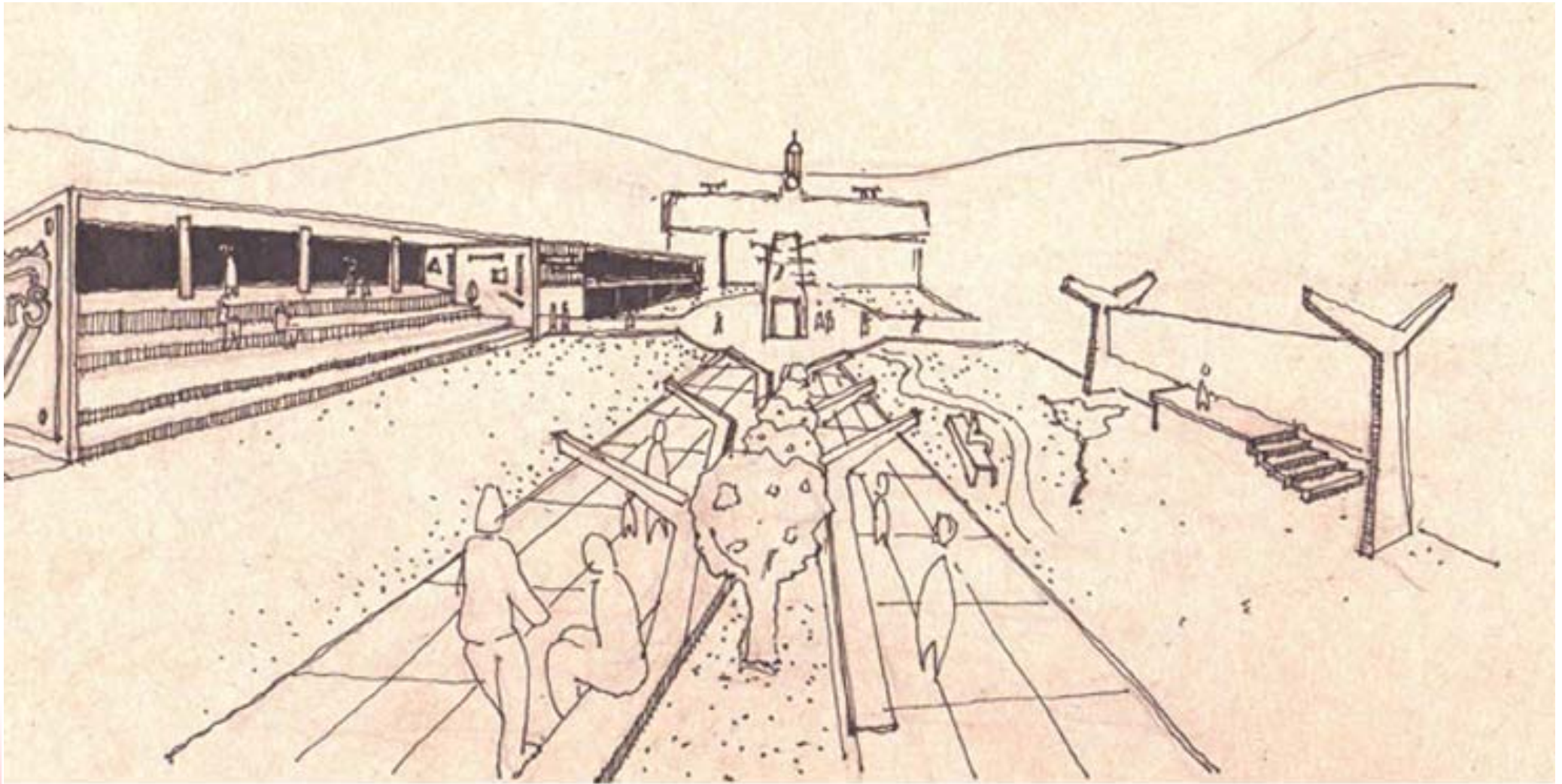

#### CONCEPTUAL CIVIC SQUARE PERSPECTIVE

Characterised by the articulated Church square linear axis. People movement occurs mainly on two perpendicular axii. Where the perpendicular axii intersect lies the centrally place water feature with orientation obelisk, and drinking fountains, and also the meeting junctions. The building on the left combined with the screen on the right contain the square and create the sense of enclosure.

The new buildings are scale-sensitive in relation to the existing Sir Herbert Baker building, thus maintaining its visual hierarchy.

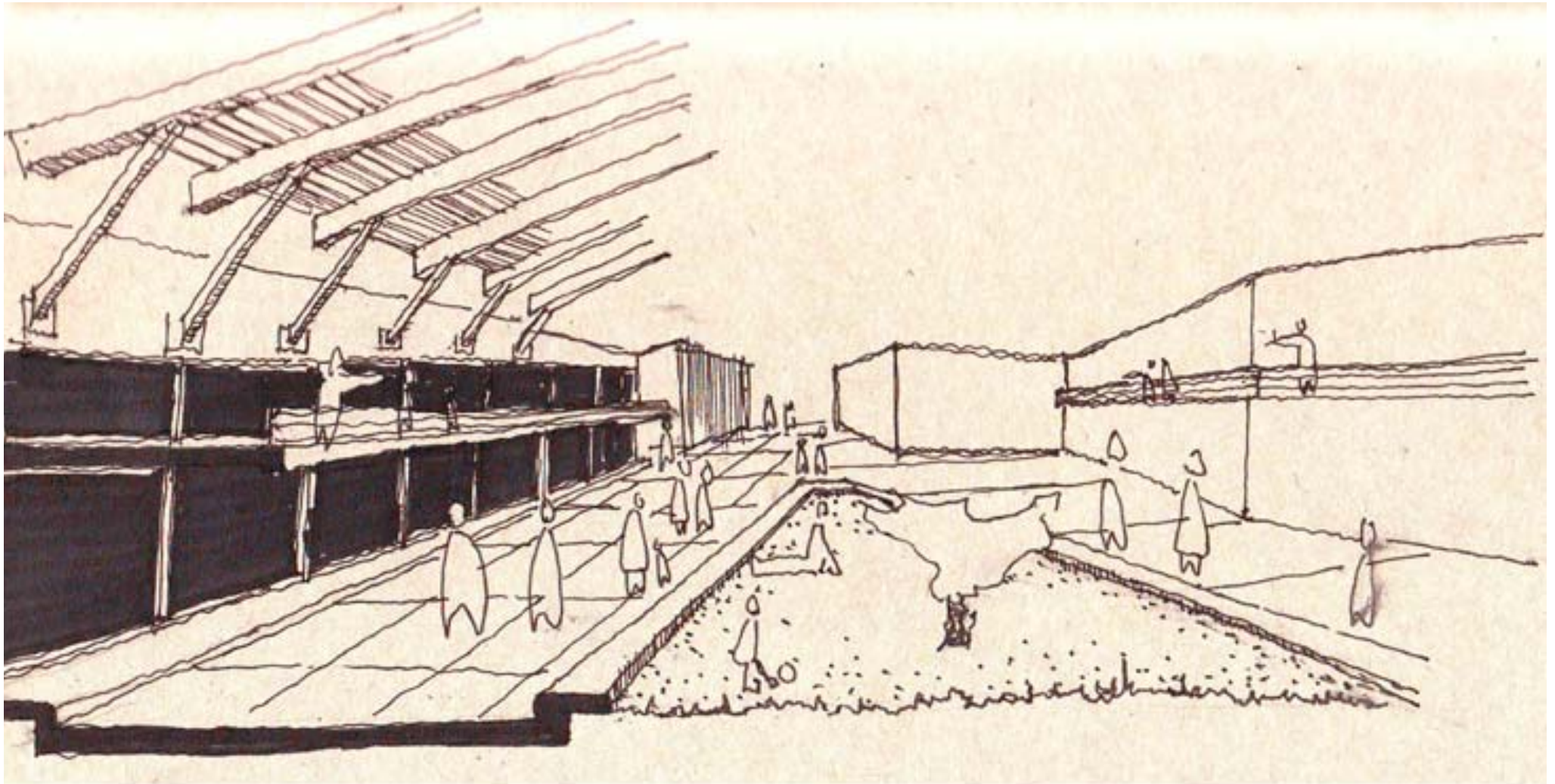

#### CONCEPTUAL UNCOVERED COURTYARD

The courtyard brings green space into the development. It is intentionally uncovered in order to capitalise on the moderate climate, and to offer the feeling of being truly in the outdoors. To the building it acts as a light well, thus keeping the enclosing facades well lit.

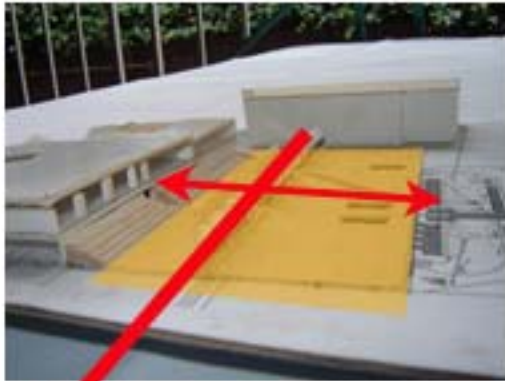

CONCEPTUAL MODEL

Initial development and articulation of movement routes, highlighted by the main spine and a single perpendicular secondary axis. The secondary axis connects the taxi rank to the proposed new bus terminus.

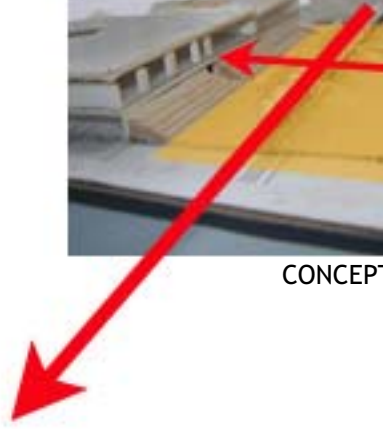

The progression sees the introduction of the second perpendicular secondary axis which connects the taxi rank to the Salvokop bridge, and still maintaining the main spine. The movement patterns start to become defined and legible. The previously existing parking on the square is removed altogether, and the square is reclaimed as a public space. The sunken garden is removed and the square is set on two levels, namely the walkway, and square level. Public amenities are introduced by means of drinking fountains on the square, and public ablutions.

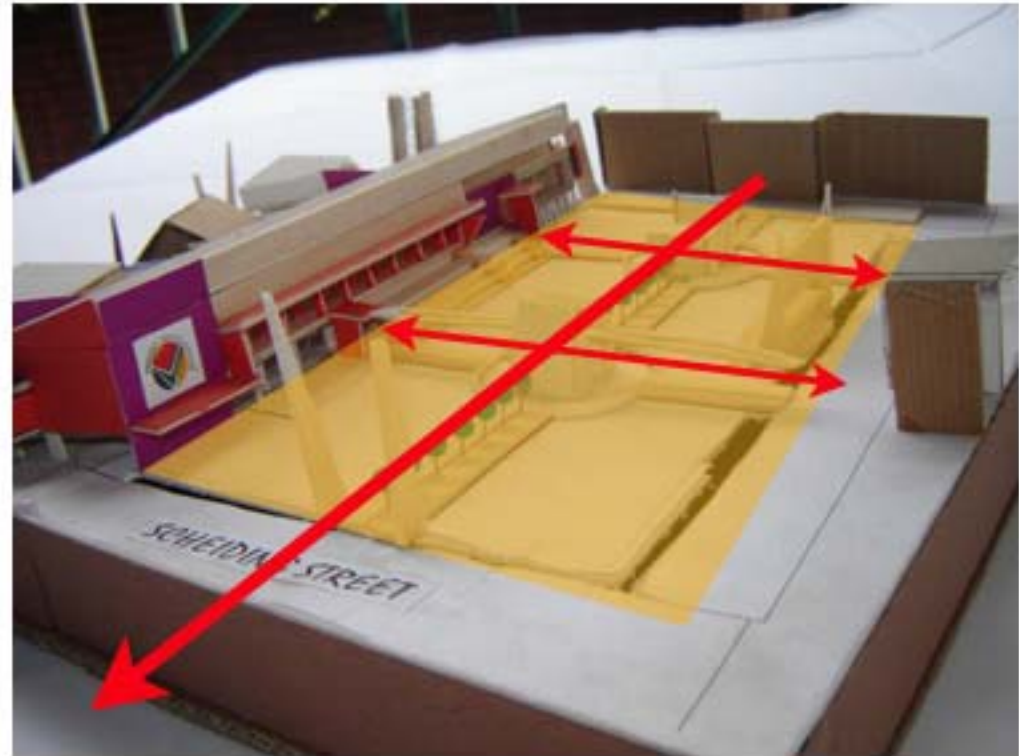

DEVELOPMENT MODEL



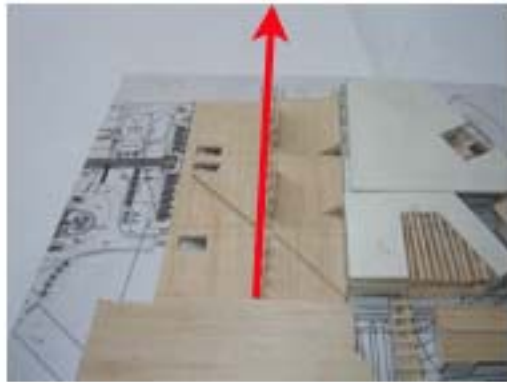

CONCEPTUAL MODEL

The square orientation and main axis feeds off from the Paul Kruger street axis, creating a pedestrian continuation of the street.



Looking towards the city.  
Maintaining and prioritising the main axis through a walkway.

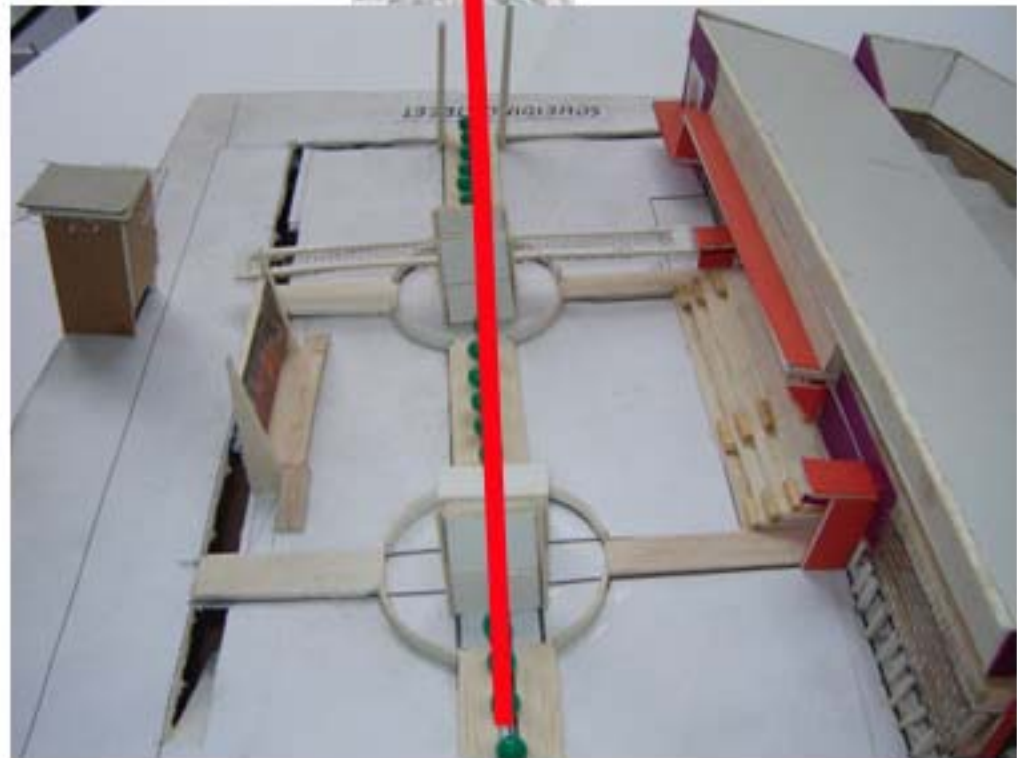

DEVELOPMENT MODEL



CONCEPTUAL MODEL

Initially, a red concrete box covered the restaurant area overlooking the square. This feature becomes a prominent element that visually attracts people towards the restaurant space, and creates a lively intervention on the facade.

The red concrete box evolves in shape and doubles as walkway covering. A stark contrast is created by the introduction of purple coloured sections of the wall to further add liveliness to the facade.

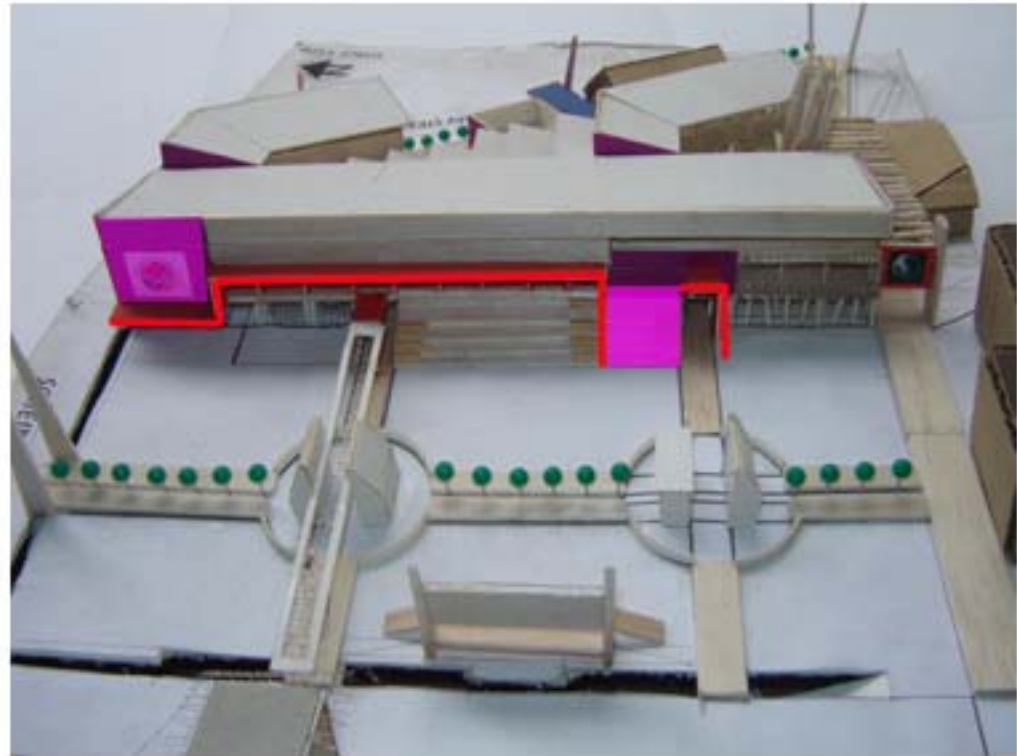

DEVELOPMENT MODEL



CONCEPTUAL MODEL

The initial location of the LED screen, along the main spine is illustrated. The screen is located such that it is fully visible from all the restaurants located on the first floor and overlooking the square.

The relocation of the screen and the symmetrical positioning, in order to accommodate a wider viewing angle.

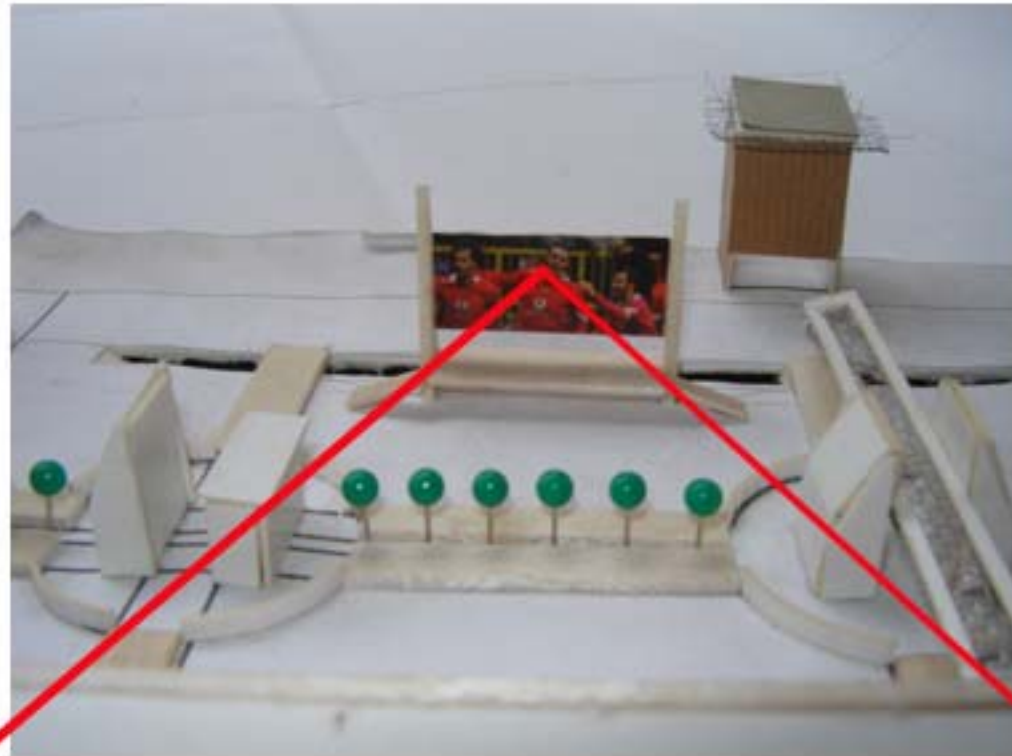

DEVELOPMENT MODEL



North west aerial view

CONCEPTUAL MODEL



North west aerial view

DEVELOPMENT MODEL



North east aerial view

CONCEPTUAL MODEL



North east aerial view

DEVELOPMENT MODEL



South east aerial view

CONCEPTUAL MODEL



South east aerial view

DEVELOPMENT MODEL



South west aerial view

CONCEPTUAL MODEL

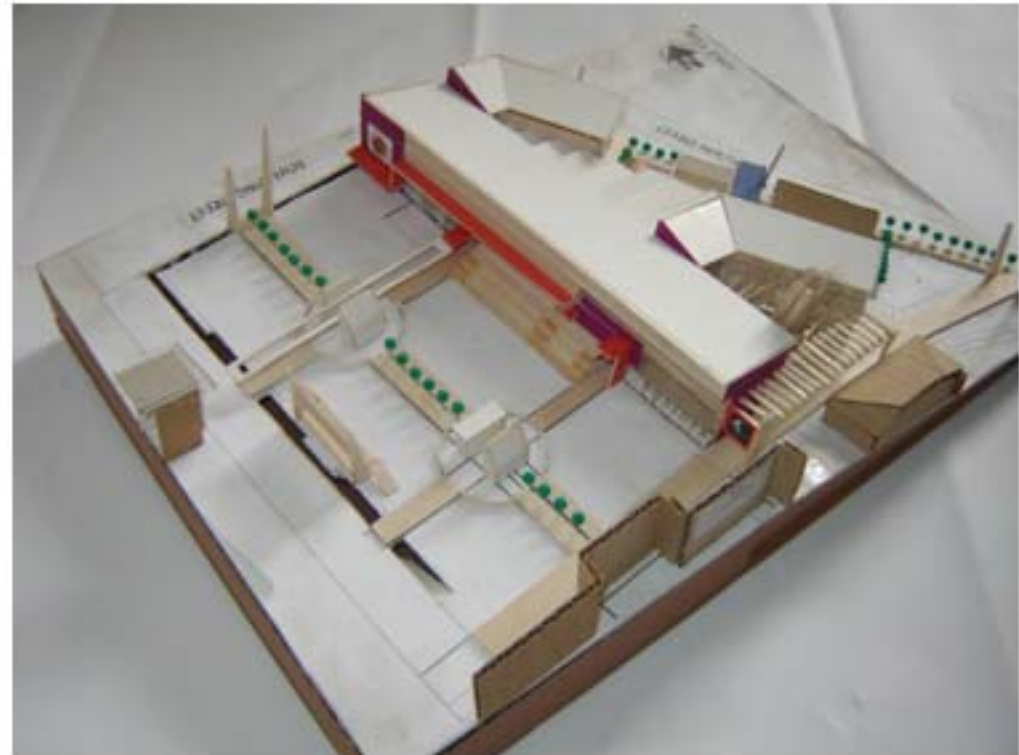

South west aerial view

DEVELOPMENT MODEL





#### APPROACH TO TECHNICAL INVESTIGATION

The technical composition of the building attempts where possible to minimise the use of materials with a high embodied energy towards arriving at a sustainable building. The construction technology is relatively simple to accommodate low skilled labour in order to afford job opportunities during the construction period. Emphasis is placed on locally manufactured and available materials. Another consideration is the life-cycle costs, which are kept at a minimum through the employment of simple technology. The building capitalizes on passive climate control elements thus reducing the need for energy consuming climate control means.

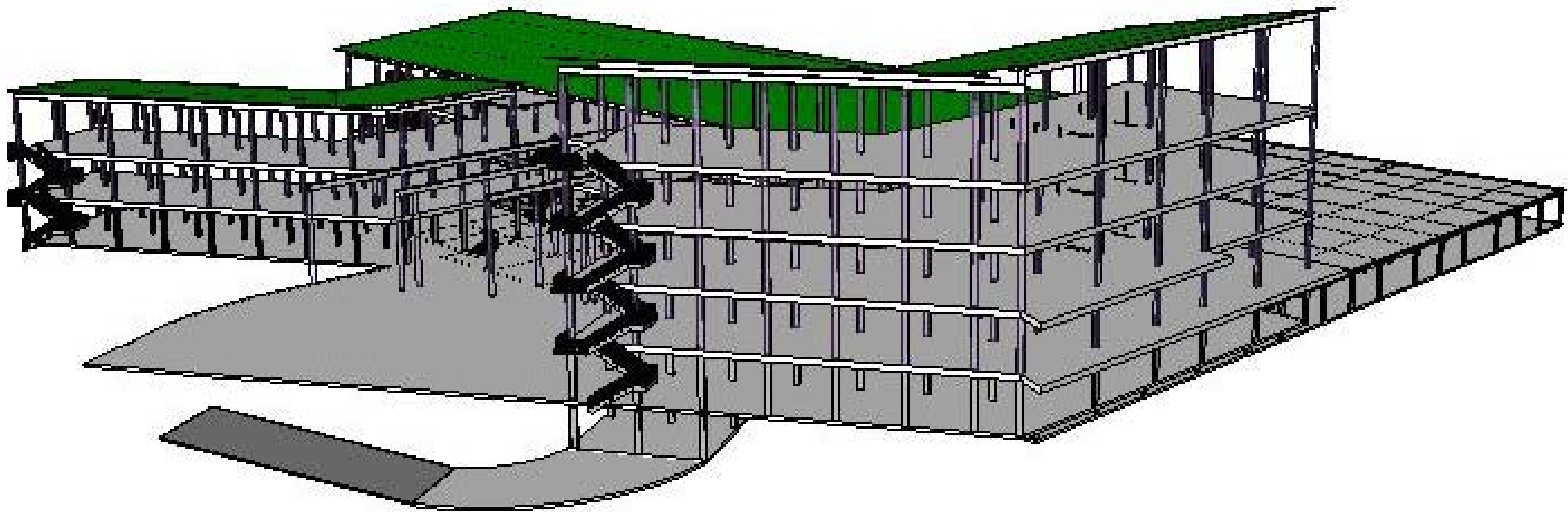

NORTH EAST VIEW STRUCTURE MODEL

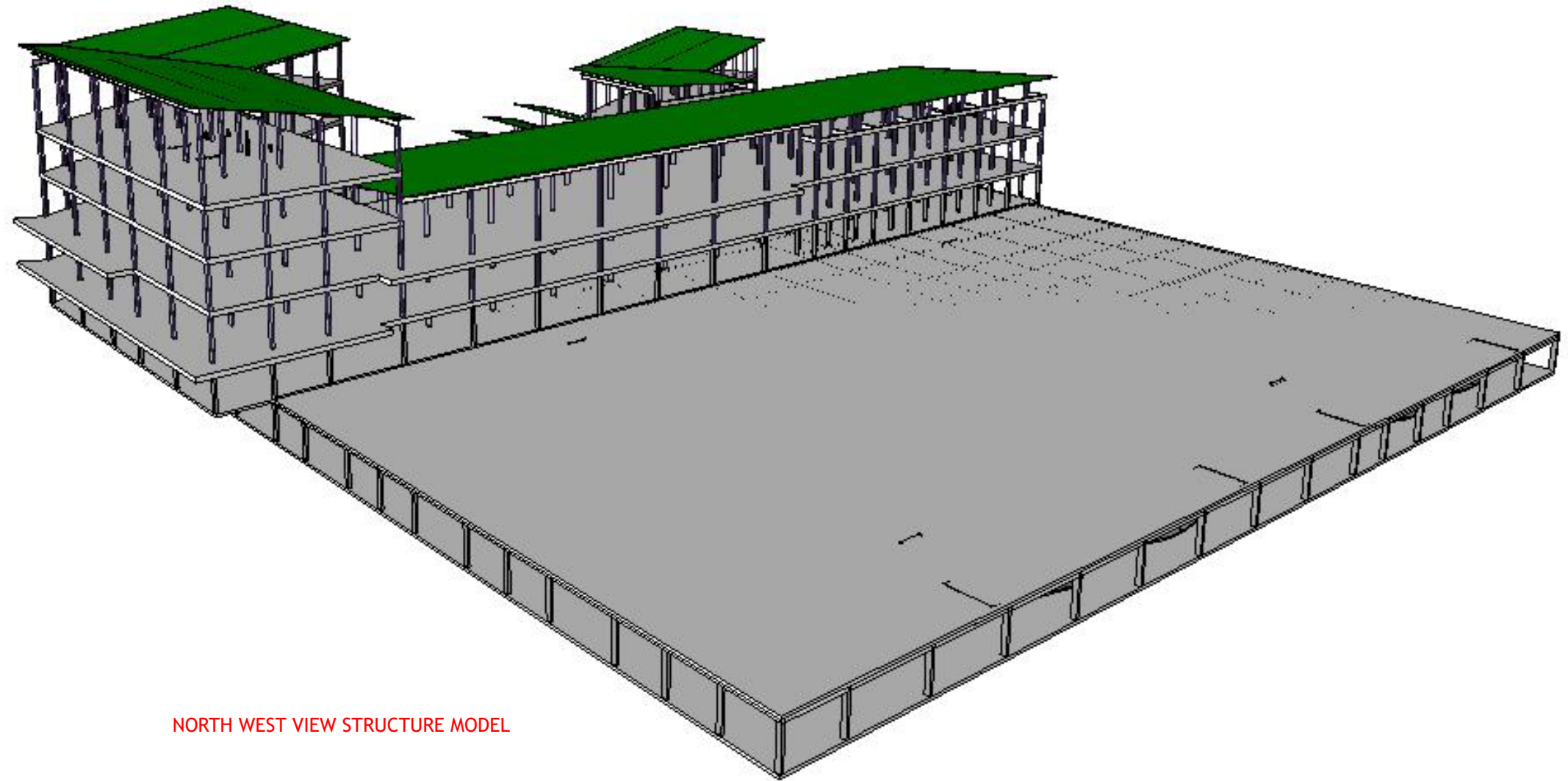

NORTH WEST VIEW STRUCTURE MODEL

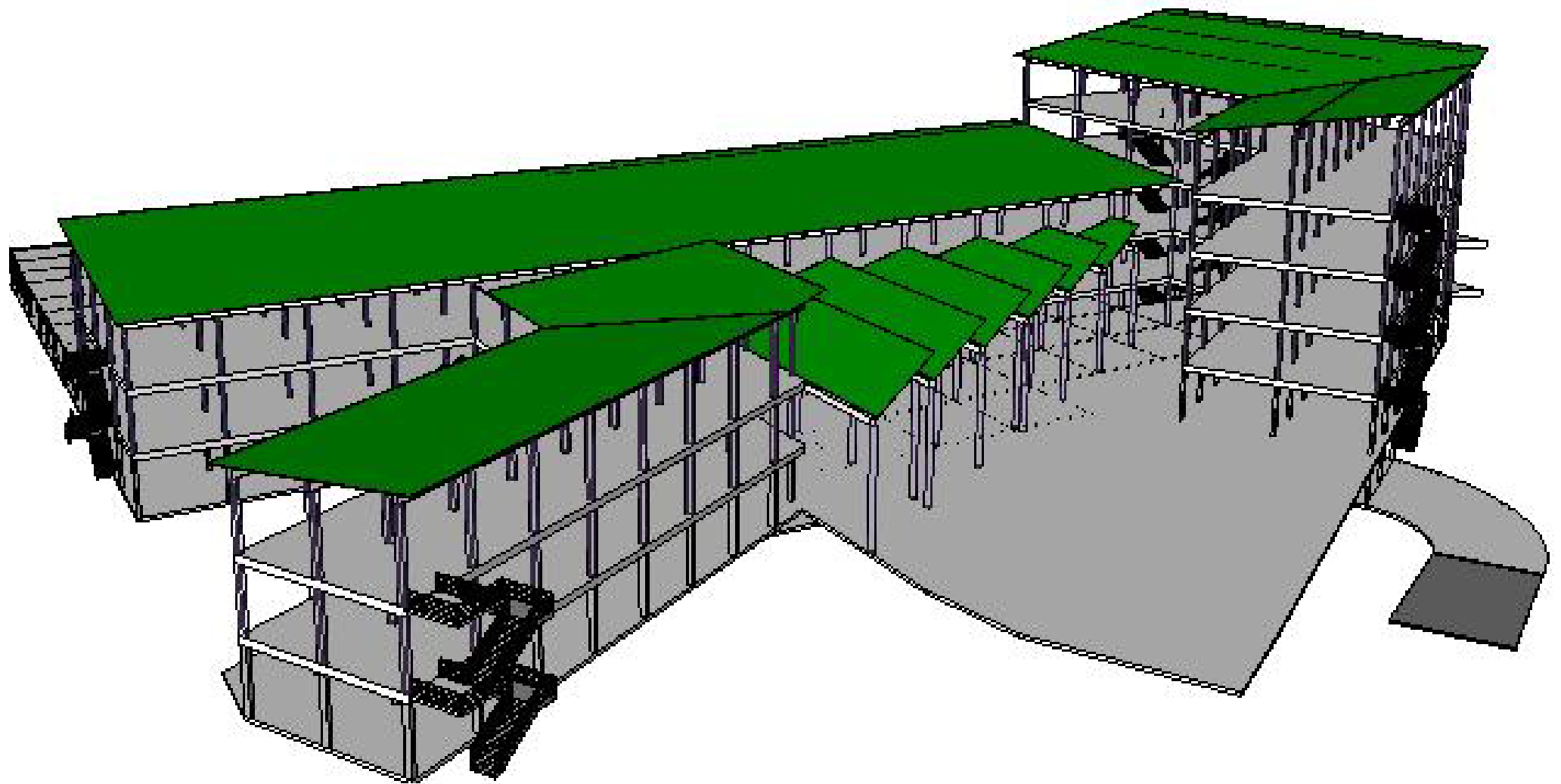

SOUTH EAST VIEW STRUCTURE MODEL

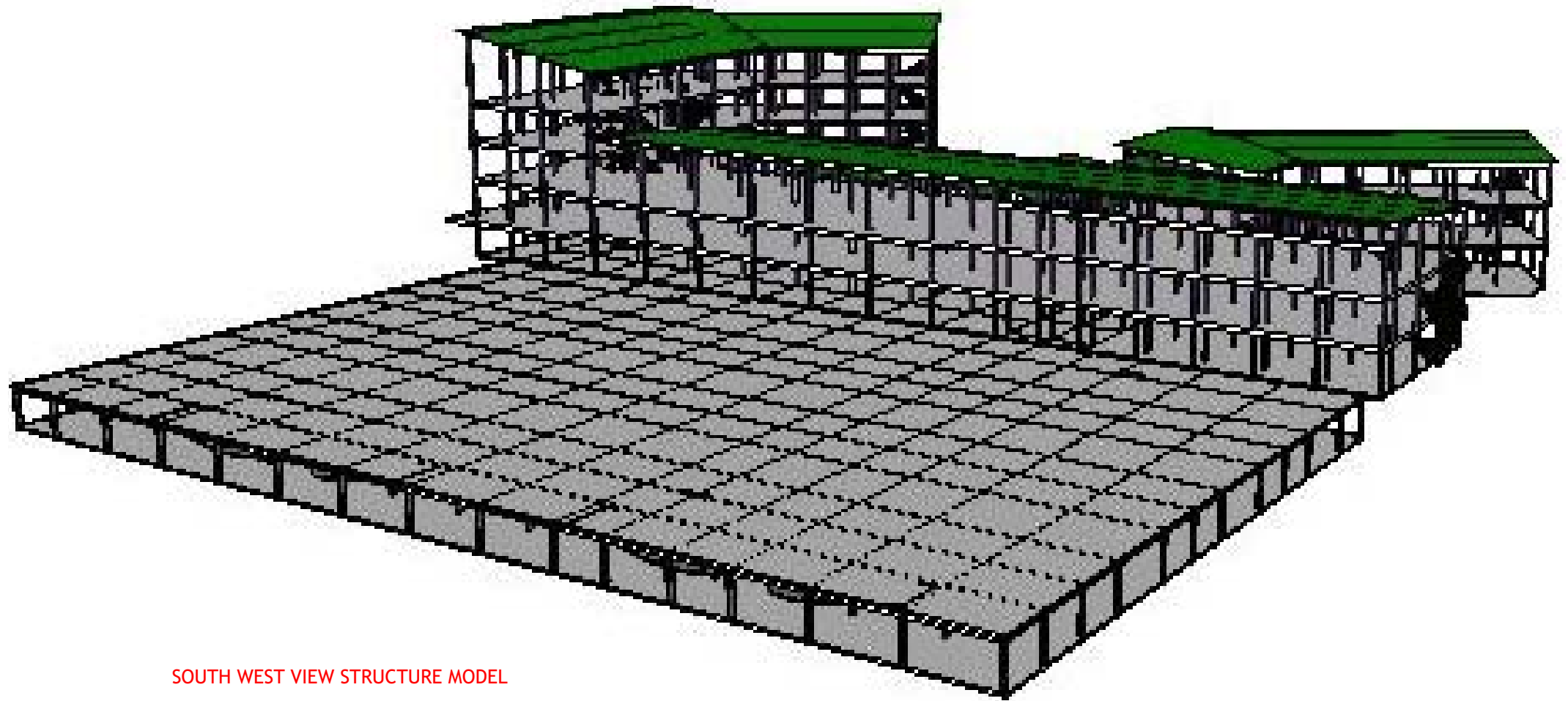

SOUTH WEST VIEW STRUCTURE MODEL

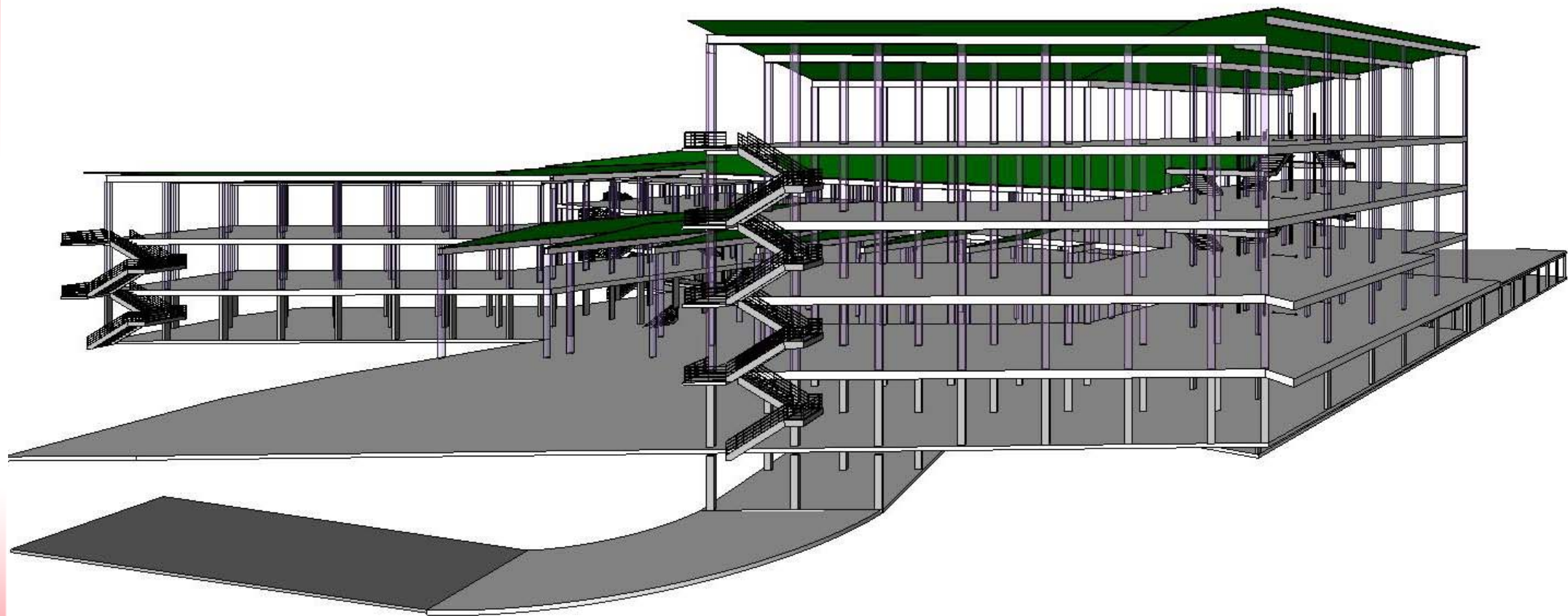

VIEW 1 STRUCTURE MODEL

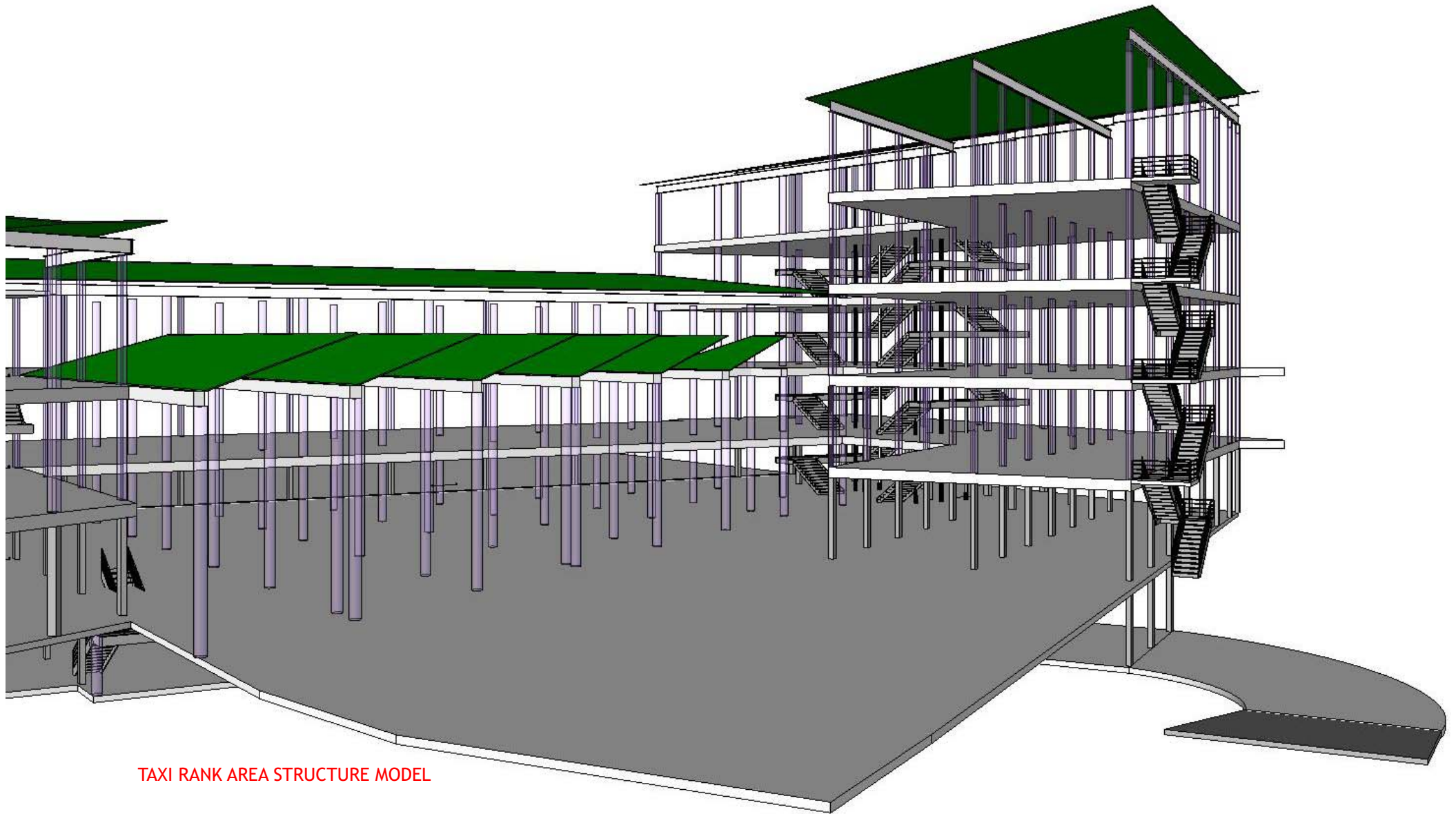

TAXI RANK AREA STRUCTURE MODEL

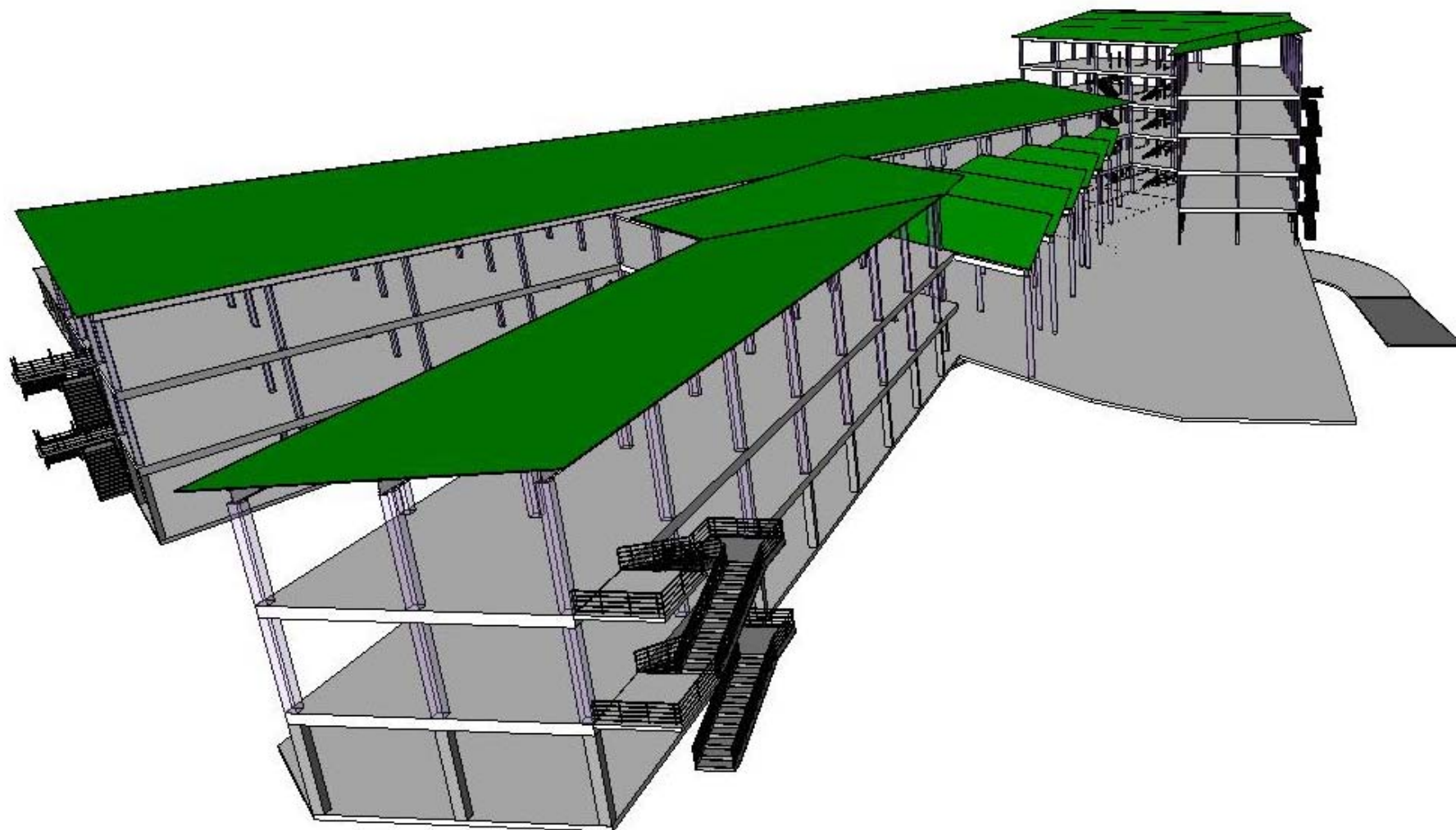

SOUTH BIRD'S EYE-VIEW STRUCTURE MODEL



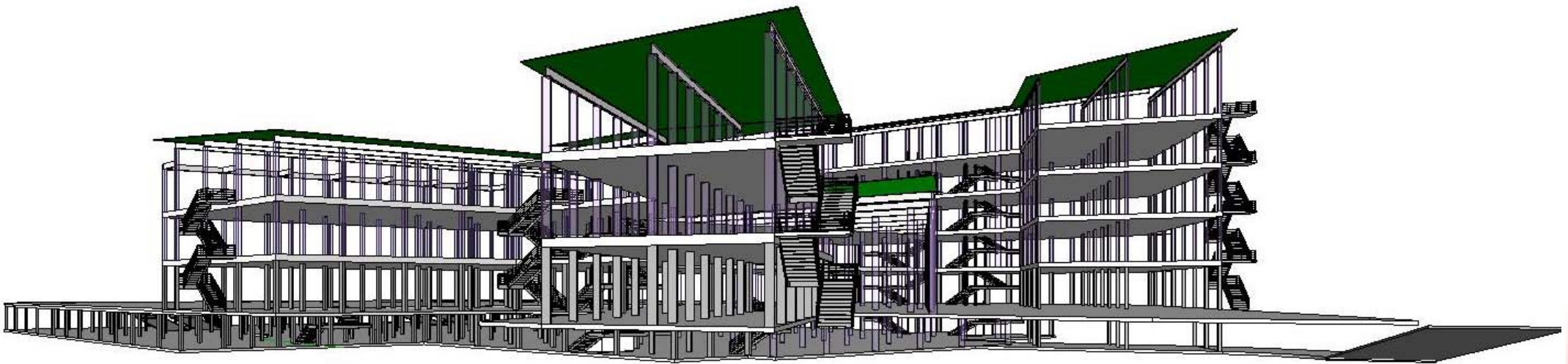

SOUTH WORM'S EYE-VIEW STRUCTURE MODEL

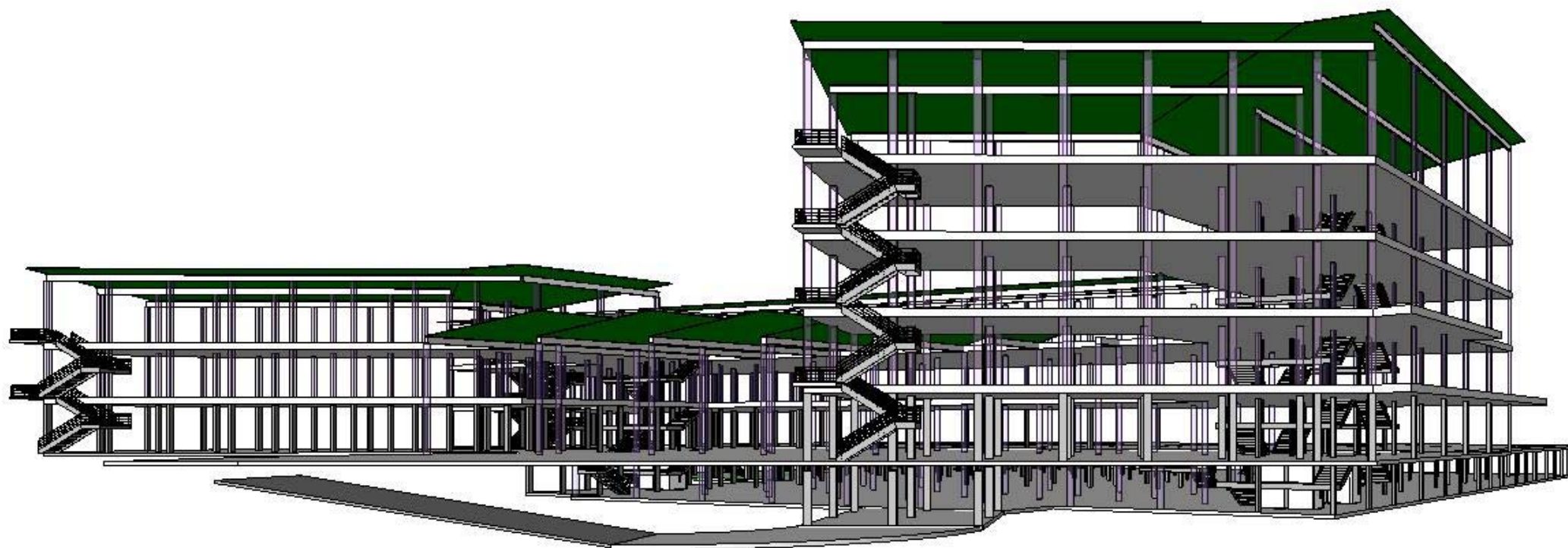

LEVELS STRUCTURE MODEL

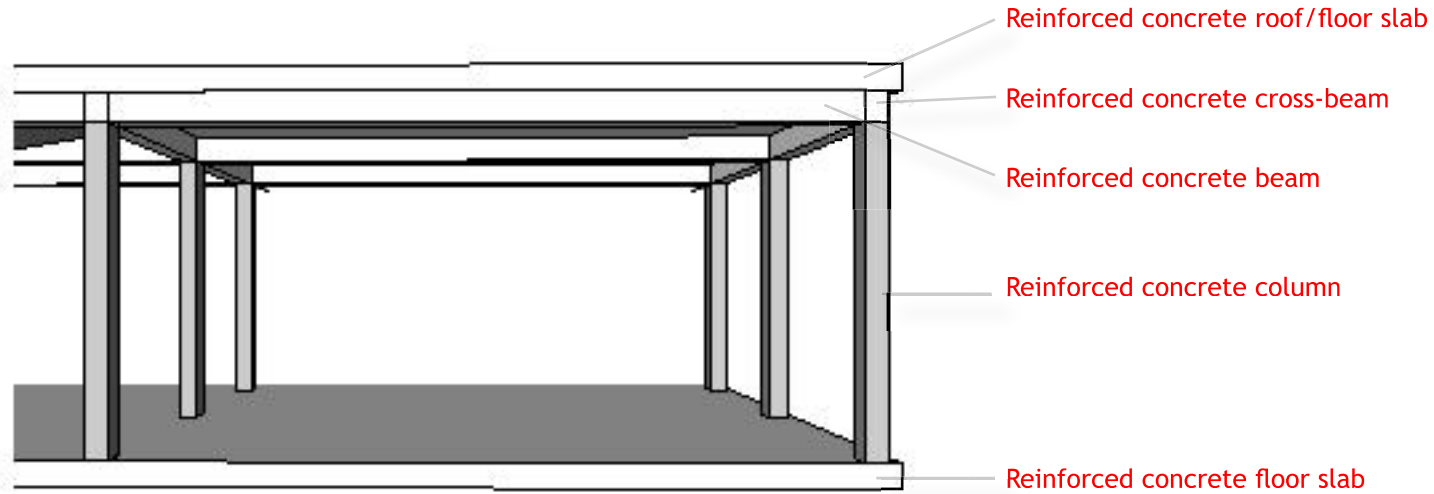

STRUCTURAL COMPOSITION OF BASEMENT

STRUCTURAL COMPOSITION OF THE BUILDING

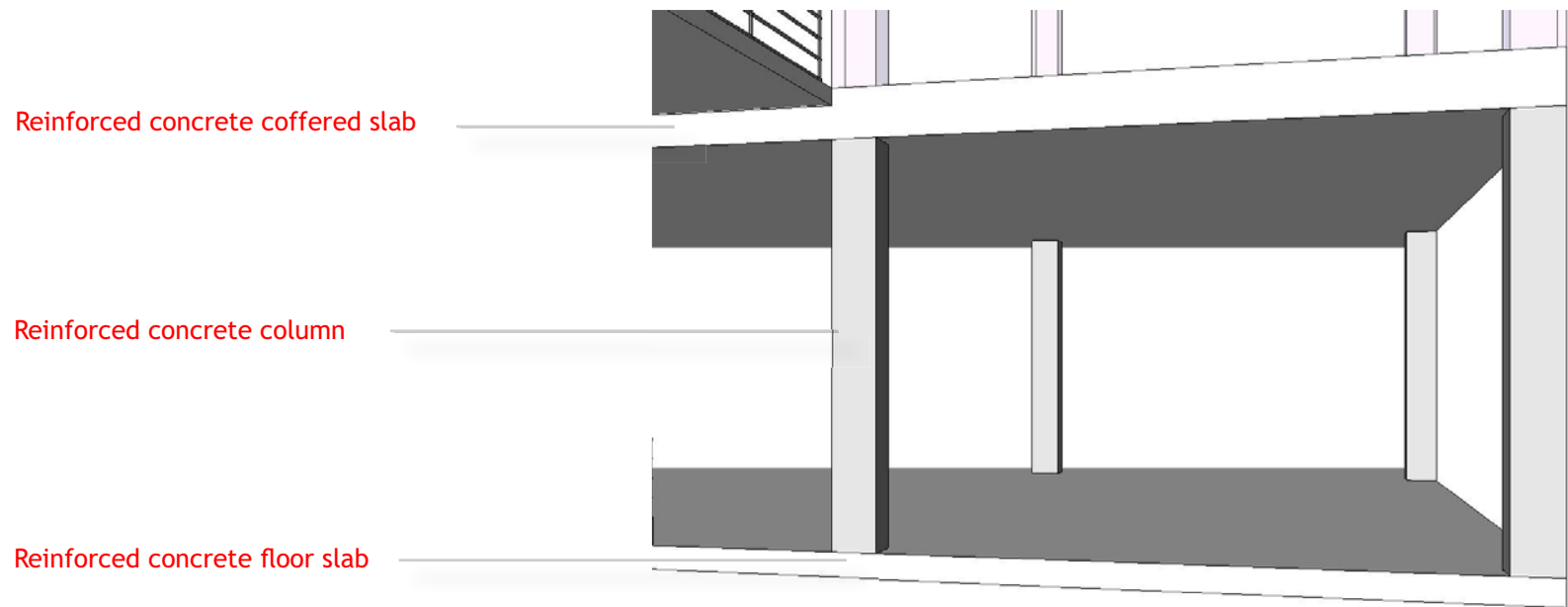

## SUB STRUCTURE

### FOUNDATIONS

Raft foundations are best suitable for the combination of Quartzite and shale soil formation. Raft foundations are particularly ideal for spreading heavy column loads evenly over the entire area of the site.

A layer of 100mm thick concrete blinding is necessary under the raft foundation to protect the waterproofing membrane.

A reinforced concrete mix of 1:2:4/20mm aggregate with a strength of 25 MPa, at 28 days is ideal.

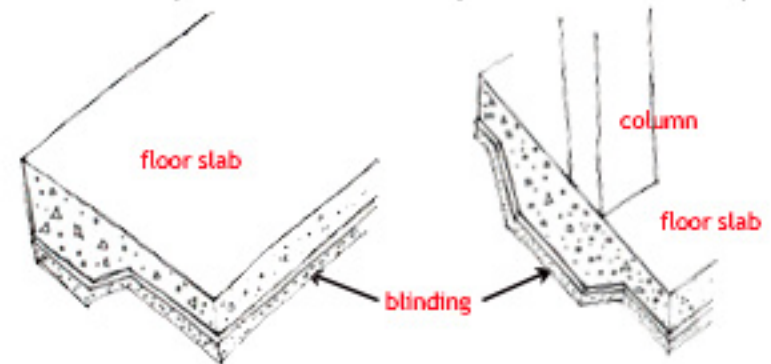
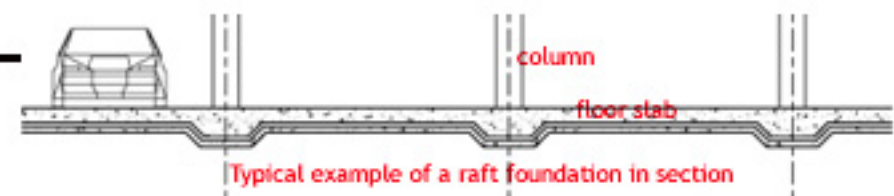

### BASEMENT WALL

230mm reinforcement concrete basement wall protected on the outside by a 115mm masonry brick wall.

A reinforced concrete mix of 1:2:4/20mm aggregate with a strength of 30 MPa, at 28 days is ideal.

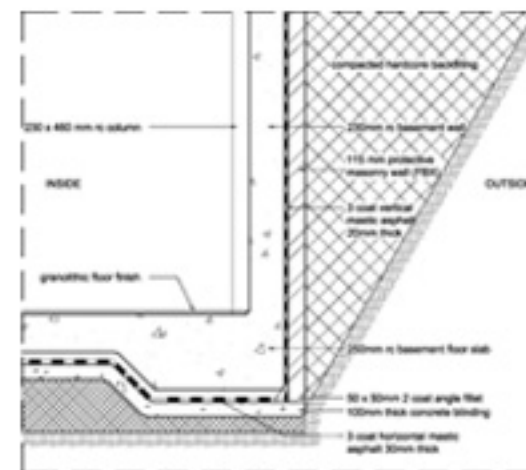

Basement wall detail

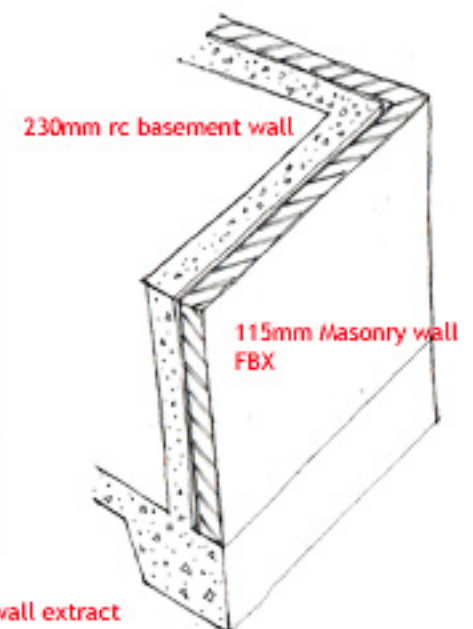

Basement wall extract

## SUPER STRUCTURE

### SLABS/FLOORS

500mm Deep coffered slabs are used generally on the project for construction economy. Coffered slabs require less concrete in comparison to slab and beam construction furthermore, the need for reinforcements is reduced, the need for beams is almost eliminated. The two-directional span properties allow for large floor spans between column supports. The underside can be exposed for visual aesthetics. Coffered slabs can also act as mass floors, thus helping to regulate the interior climate, this is ideal for a climate zone with a high diurnal temperature variation. The finish applied on the slab will be determined by the space usage.

A reinforced concrete mix of 1:2:4/20mm aggregate with a strength of 25-30 MPa, at 28 days is ideal.



Typical example of a coffered slab in section



Typical coffered slab profile



Typical coffered slab 3d extract

### COLUMNS

Two types of structural columns are used throughout the structure.

1. Rectangular 460 x 230mm rc columns.
2. Cylindrical diameter 460mm rc columns.

The use of 460 x 230mm columns is motivated by the ability to fit flush depending on the orientation within a 230mm masonry wall. However the cylindrical columns will be used in the taxi rank area, where there is no masonry infill between the columns. Artwork mosaic tiles are to be cladded onto the cylindrical columns.

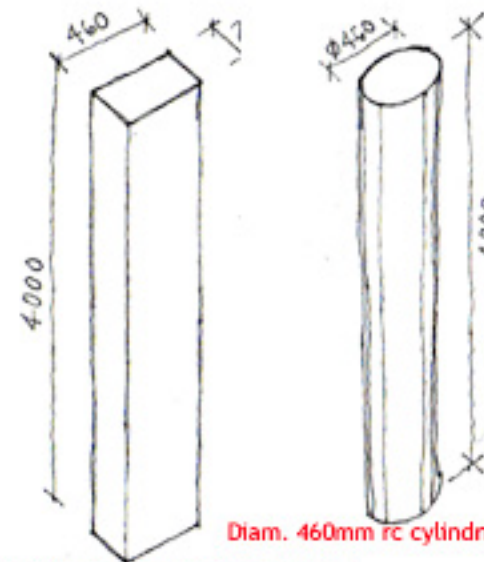

460 X 230mm rc rectangular column

Diam. 460mm rc cylindrical column



Example of column art treatment. (Architecture SA Nov/Dec 2004:36)



Example of column art treatment. (Aedes 2005:13)

## IN-FILL

## WALLS

3 types of infill walls are used throughout the structure.

1. 230mm Masonry wall
2. 115mm Masonry wall
3. 100mm Rhinoboard partitions.

The 230mm wall is generally used as outside walls of the infill structure, the 115mm walls are used internally only, and the partitions are used mainly in the ablutions and office spaces. Common stock-bricks are used for plastered sections, while fired facebrick (FBS) is used for sections where the brick work is unplastered.

Generally the brickwork is non-structural. The city's art in public places programme (ISDF 2005) is exercised through local artists showcasing their art work on large sections of exposed walls both internally and externally. The use of bright colour paints give a inviting feeling of liveliness.

Where possible the masonry walls are used as aesthetic features, layered with various textures and colours.

Climatically the 230mm masonry walls offer a thermal mass effect.

The walls and the bonding thereof are to be SABS 0400 (1990) Part K compliant.

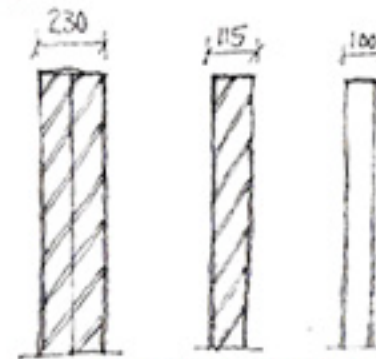

3 Types of wall thicknesses

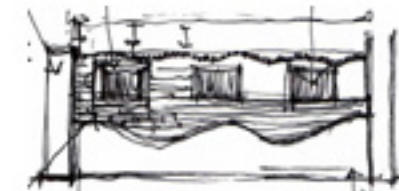

Wall texture exploration



Plastered wall extract



Effect of colours, Umkhumbane Community Health centre, Cato manor (Architecture SA Mar/April 2006:17)



Facebrick wall extract (FBS)



Facebrick example (www.corobrik.co.za)



Mural wall treatment, Bara taxi rank (Aedes 2005:23)

## IN-FILL

## CURTAIN WALLS

Two types of glazing technology are employed throughout the structure, namely the framed glazing, and patch-fitted glazing panels. The aluminium framed glazing panels are in the form of Solar Insulated Glazing Units (SIGU), with an air space of 12mm with varying glazing thickness according to the type of glazing selected.

The use of SIGU is motivated by its climate control properties, which are especially beneficial in combating the high diurnal temperature changes of the Northern Steppe climatic region. The selection of glazing will be informed by the orientation of the facade, in order to reduce heat loads and solar radiation. To further add to climate comfort, the framed glazing panels are to have opening section that will allow for cross-ventilation through the structure. Another advantage of the glazed curtain wall system is the opportunity of taking advantage of the ample daylight available in this particular climatic region.

The patch-fitted glazing units are generally 25mm thick, however, the glazing selection is also subject to the orientation of the facade. The patch fittings are made from stainless steel, and the gaps between the glazing panels are filled with clear silicone sealant.

All glazing panels and fixing thereof is to be SABS 0400 Part N compliant.

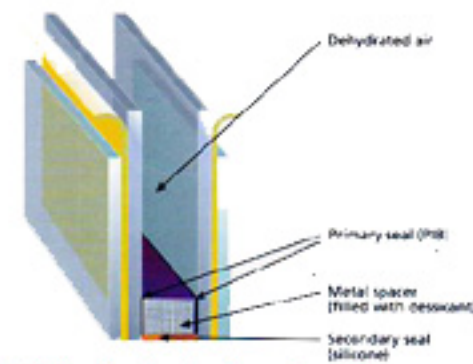

SIGU detail, obtained from Smartglass catalogue



SIGU sample panel, obtained from Smartglass catalogue

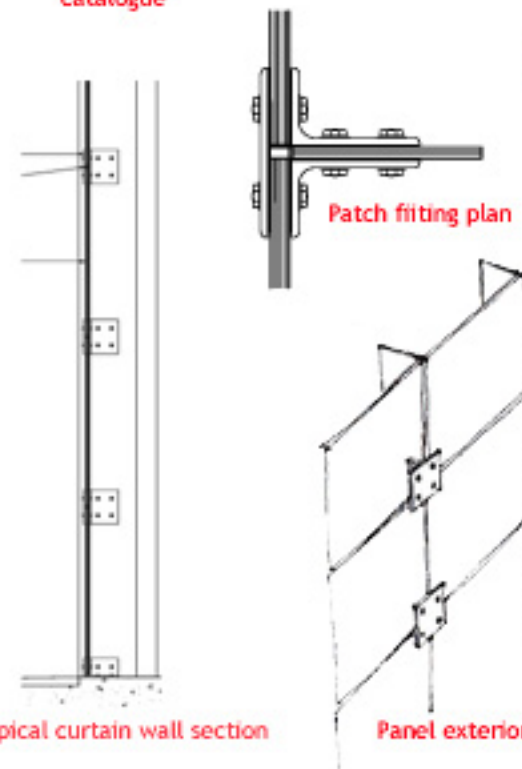

Typical curtain wall section

Panel exterior

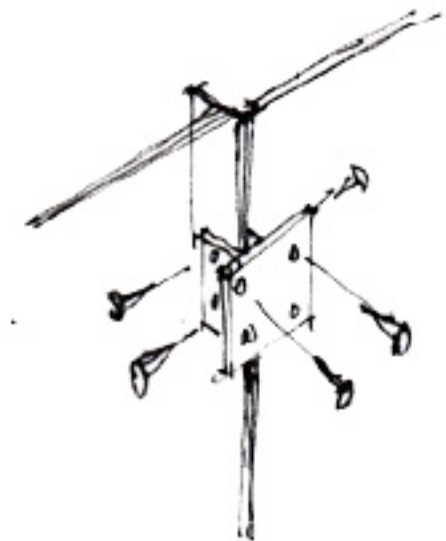

Exploring the method of fixing the glazing

## COVERING

## GALVANIZED SHEETING ROOFS

Two types of roofs are used throughout the structure.

1. Galvanized metal sheeting, Craft-Lock profile.
2. Reinforced concrete flat roofs.

Generally the Craft-lock profile supported by steel trusses is used for over 90% of the entire structure. Galvanized metal roofing is used primarily because it is a lightweight type of roof, as required for optimum climatic comfort for the Northern steppe climatic zone. The Craft-lock profile is preferred since it has concealed fixing cleats to the purlins/lipped channels, opposed to the bolt/nail technique, thus reducing the chances of water leaks, and consequently, maintenance costs. The Craft-lock profile is deep therefore helps water run-off at a pitch as low as 3 degrees.

The execution of the roof construction must be SABS 0400 (1990) compliant.

## RC FLAT ROOF

Reinforced and waterproofed concrete flat roof with a minimum of 1:50 shall be used in selected areas. Fine crushed rock pebbles are to be placed on top of the torch-on waterproofing membrane for thermal insulation. Concrete roofs are used economically, only in sections where the galvanized sheeting creates awkward junctions, to avoid high maintenance costs.

A reinforced concrete mix of 1:2:4/20mm aggregate with a strength of 30 MPa, at 28 days is ideal. The execution of the roof construction must be SABS 0400 (1990) compliant.



Craft-lock sheeting profile (Clotan Steel Catalogue)

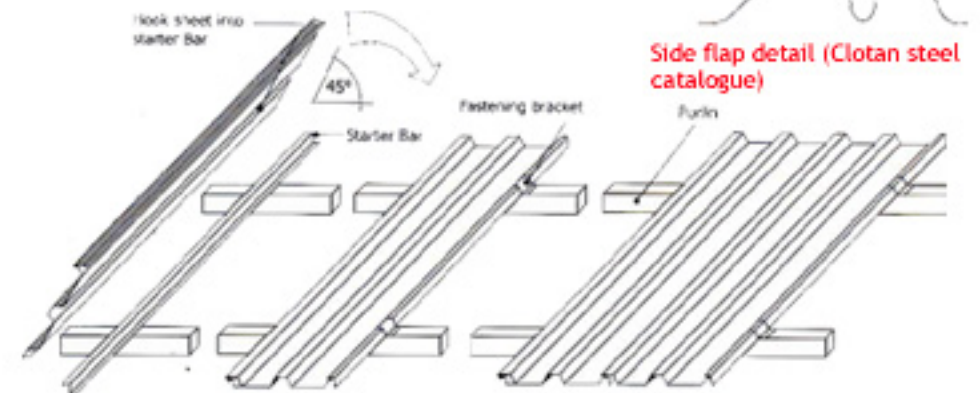

Sheeting erection process (Clotan steel catalogue)



Typical roof truss section

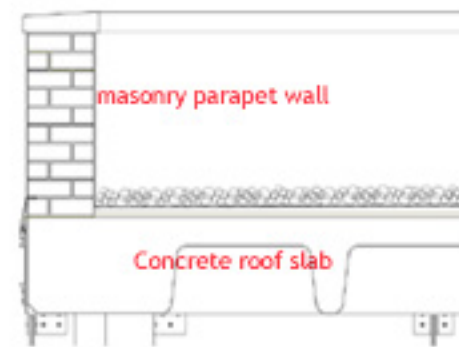

Rock pebbles used as thermal insulation.



CONNECTIONS

FIXING METHODS

Exploring means of connecting the different materials.  
 Chemical bolts are used to anchor steel to concrete.  
 Normal bolts or welding is used to anchor steel to steel

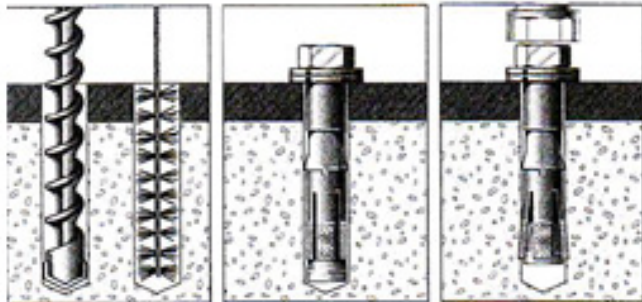

1. Drill recommended sized holes as per technical specifications. Clean hole thoroughly with brush. Remove debris by way of a vacuum pump, compressed air, hand pump, etc.
2. After ensuring anchor is assembled correctly, insert anchor through fixture and drive in until washer contacts fixture.
3. Tighten bolt with torque wrench to specified assembly torque.

Example of chemical bolts (Ramset catalogue)

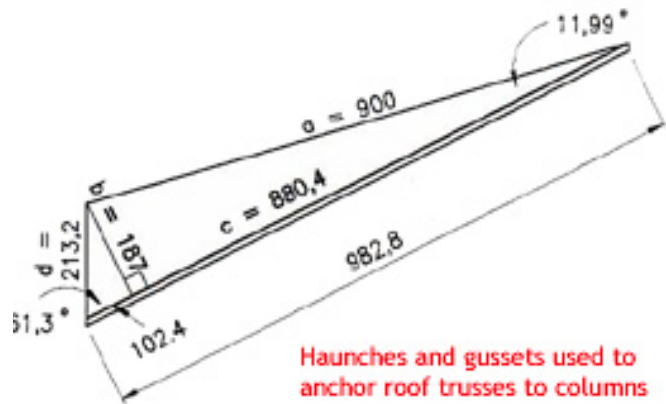

Haunches and gussets used to anchor roof trusses to columns

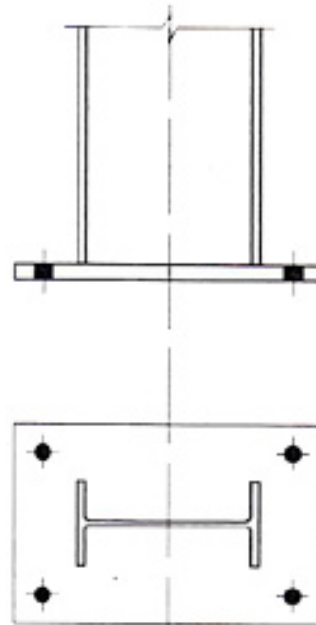

Simple slab gusset base plate (SA Structural steelwork manual)

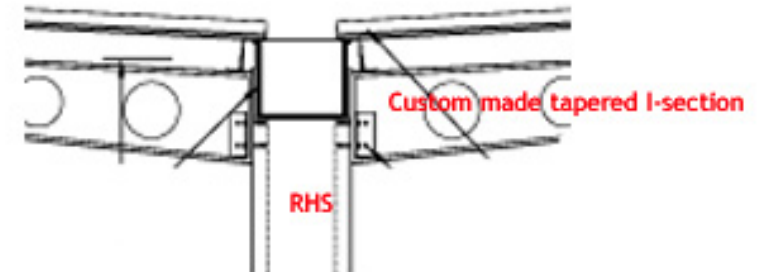

Typical walkway roof connection

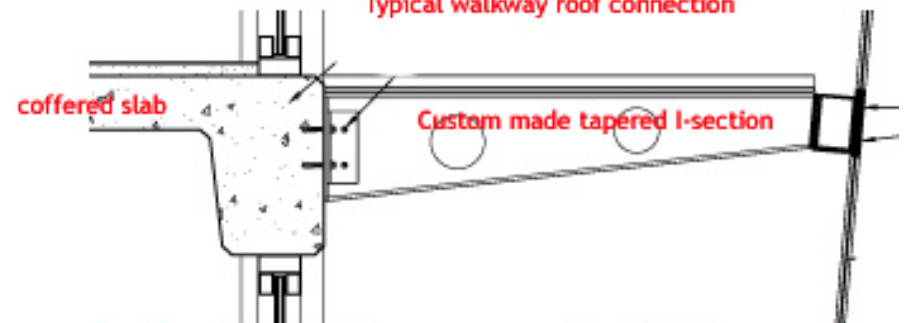

Typical mesh screen fixing to concrete coffered slab by means of steel angle cleats

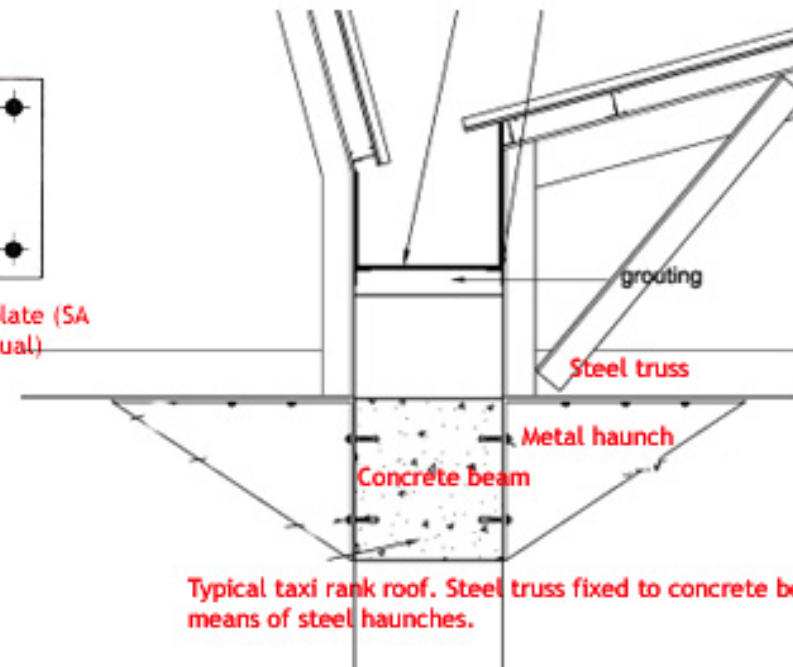

Typical taxi rank roof. Steel truss fixed to concrete beam by means of steel haunches.

### THERMAL INSULATION

#### ROOF HEAT LOAD CONTROL

Isoboard extruded polystyrene insulation board fixed on the top chord truss members is used under the Craft-lock sheeting. Isoboard is rigid and lightweight and can be fitted directly on the purlins for ease of construction. Isoboard is an ideal thermal insulator for the combating of the high diurnal temperature variations synonymous with this particular climatic region. In areas where rc flat roofing is used, rock pebbles are laid over the waterproofing membrane as thermal insulation.



Example of Isoboard insulation fixed over purlin (Architect and builder 2004:91)

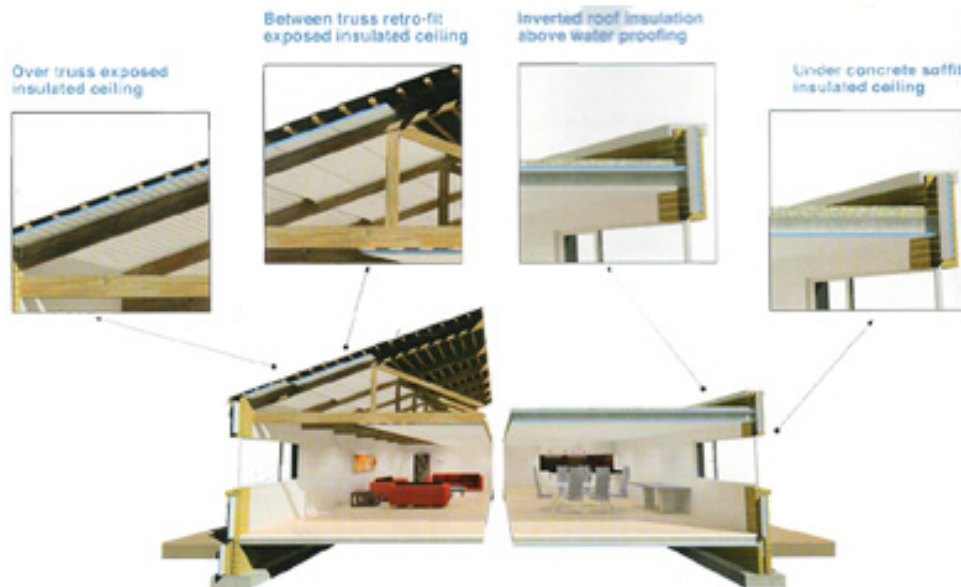

Various fixing methods of the Isoboard panels (Architect and builder 2004:91)



Example of Isoboard insulation used as a ceiling (Architect and builder 2004:91)

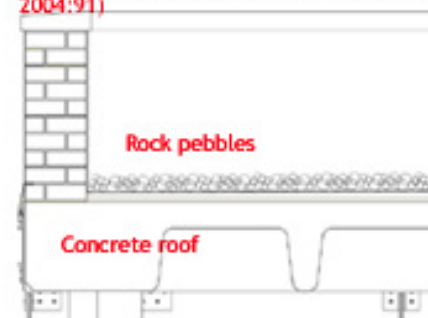

## SOUND INSULATION

## NOISE CONTROL

Noise is controlled throughout the structure by the use of Solar Insulated Glazing Units (SIGU). By virtue of being double glazed, these panels help reduce sound transfer. These double glazed units are to be fitted with Soundprufe glazing, a type of glazing manufactured with a special vinyl interlayer that offers better sound control than traditional polyvinyl butyral (PVB) interlayers.

Soundprufe glazing is used mainly in the office space and resource centre to reduce the noise pollution generating from the taxi rank.

In addition to the glazing, blinds are used to further minimise sound pollution. In sections exposed to high noise levels like the taxi rank, most of the facade employs brickwork in order to achieve mass.

All glazing and fixing to be SABS 0400 (1990) Part N compliant.

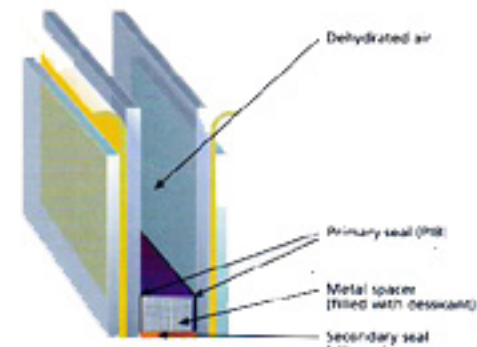

SIG unit (Smartglass catalogue)

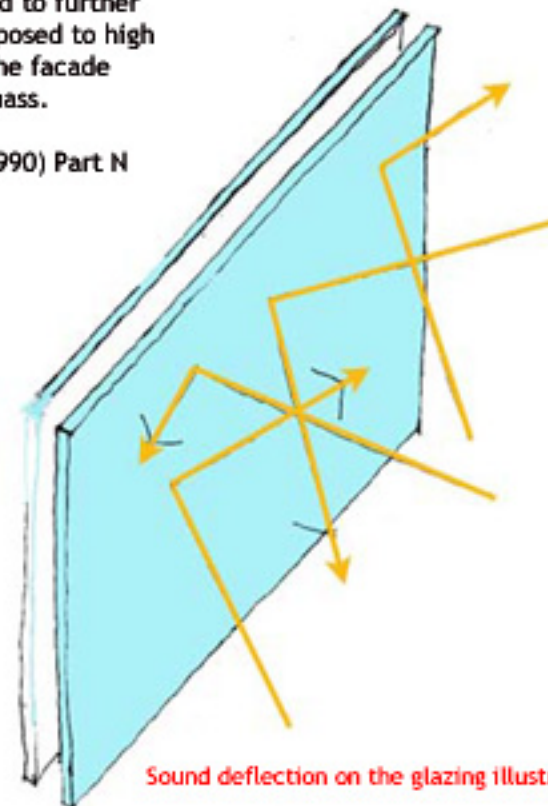

Sound deflection on the glazing illustration

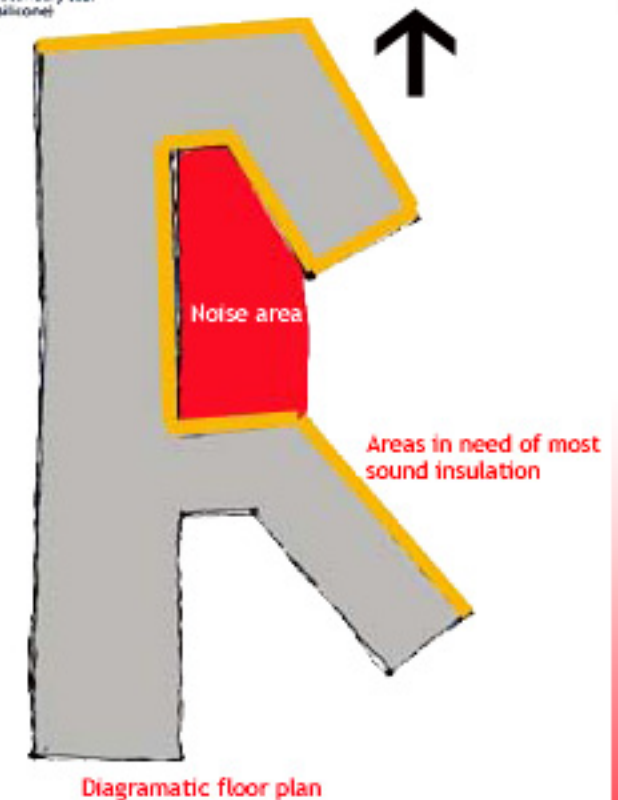

Diagrammatic floor plan

## CLIMATE CONTROL

## SOLAR PROTECTION

The Northern Steppe climatic zone is characterized amongst other factors, strong solar radiation. Such a situation necessitates solar screens and louvres, more especially on the north and west facades.

From a design perspective, the high traffic areas are recessed deeper into the structure on the northern facade, whilst on the west facade balconies act as overhangs to protect the glazing from solar gain.

The entire structure is wrapped in a stainless steel fine-grilled mesh screen, to screen out the sun, in addition the 1500mm wide horizontal placed perforated korten steel panel louvres add further solar protection. The mesh and louvres protect the surfaces from direct sun, while allowing natural light to penetrate. The selection of glazing for the curtain walling is informed by the solar properties of the glazing in relation to the elements faced on the particular facade. Generally Solarshield glazing is used for its 99% UV protection, with an additional solar reflective metallic coat to help reflect the sun's rays.

The balcony overhangs and the space between the mesh screen and the curtain wall, create a 'cooler buffer zone' between the external temperature and the internal temperature of the structure.



Sun angles for the site



Examples of the screen mesh in newtown ,JHB

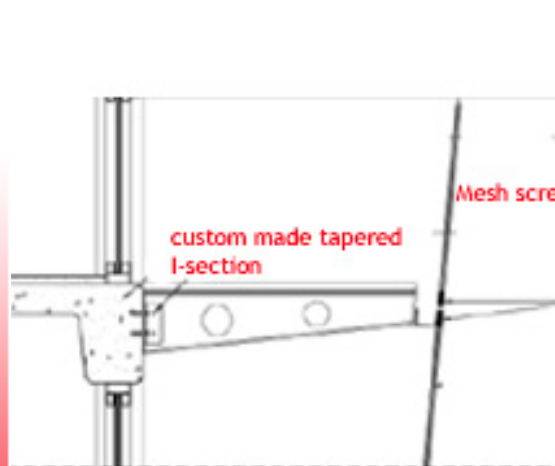

Typical north elevation screen detail

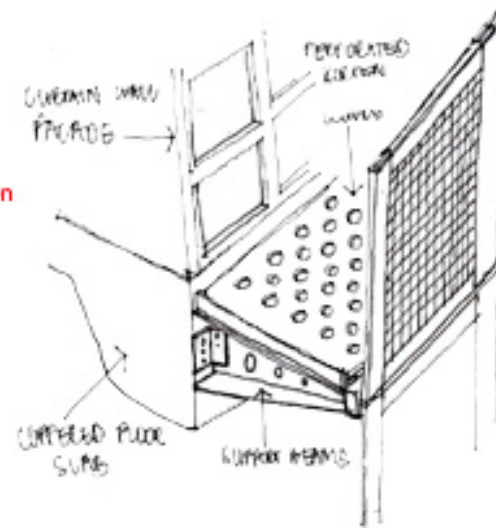

North facade screen axonometric

STAINLESS STEEL FINE GRILLED MESH IN A STEEL FRAME.



Typical east and west facade screen treatment

Vertical louvres

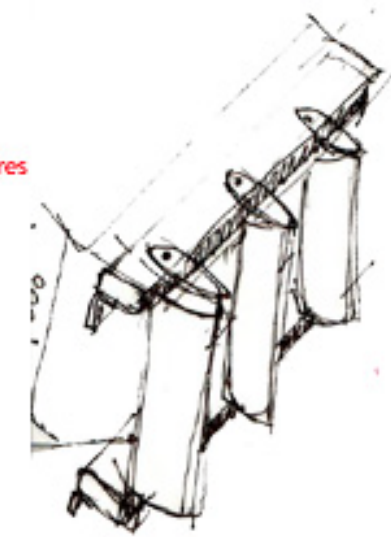

Typical east and west facade screen treatment axonometric

## CLIMATE CONTROL

## SOLAR PROTECTION

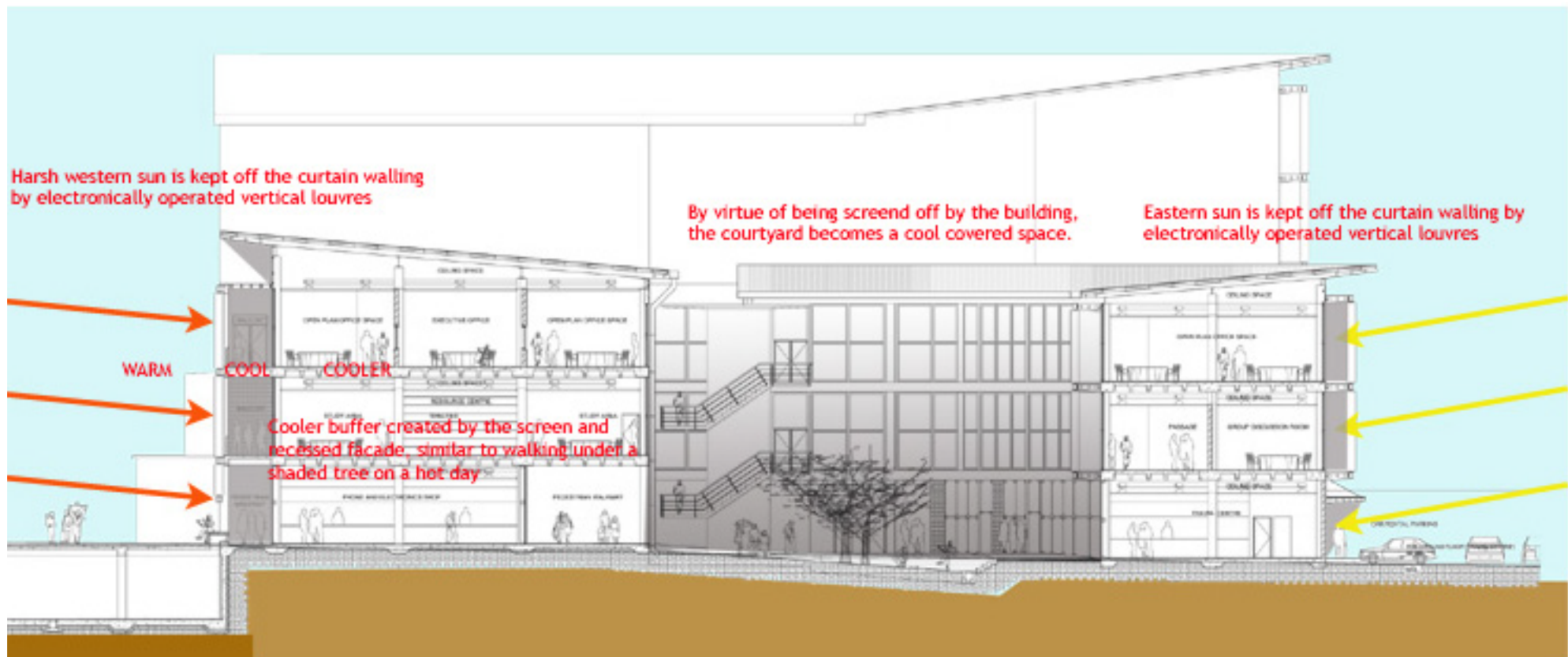

Section illustrating east and west sun conditions.

# CLIMATE CONTROL

## SOLAR PROTECTION

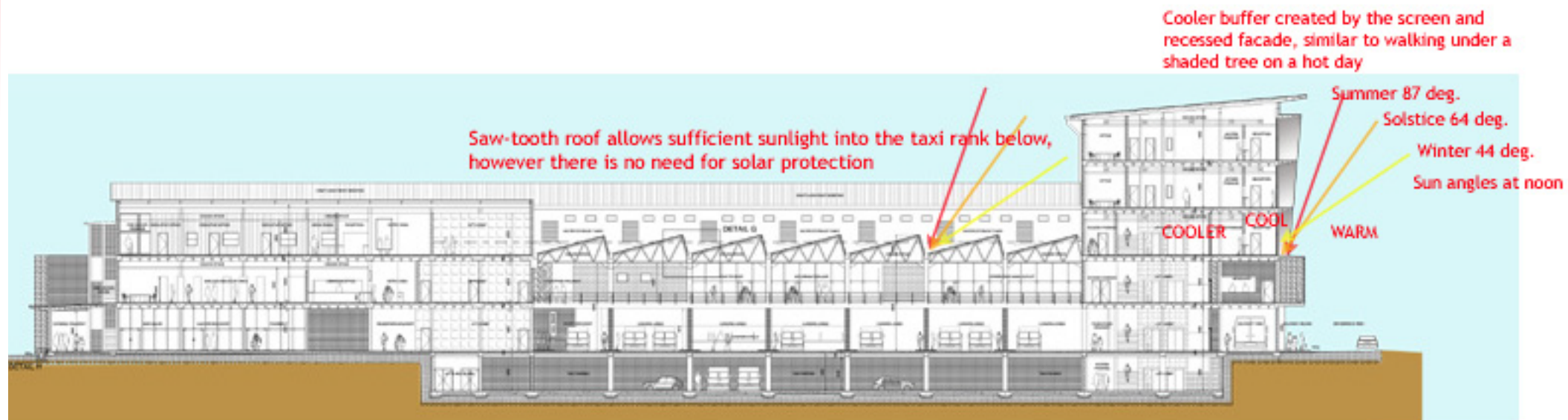

Section illustrating north sun conditions.

CLIMATE CONTROL

LIGHT PENETRATION



Section illustrating light penetration from the north.

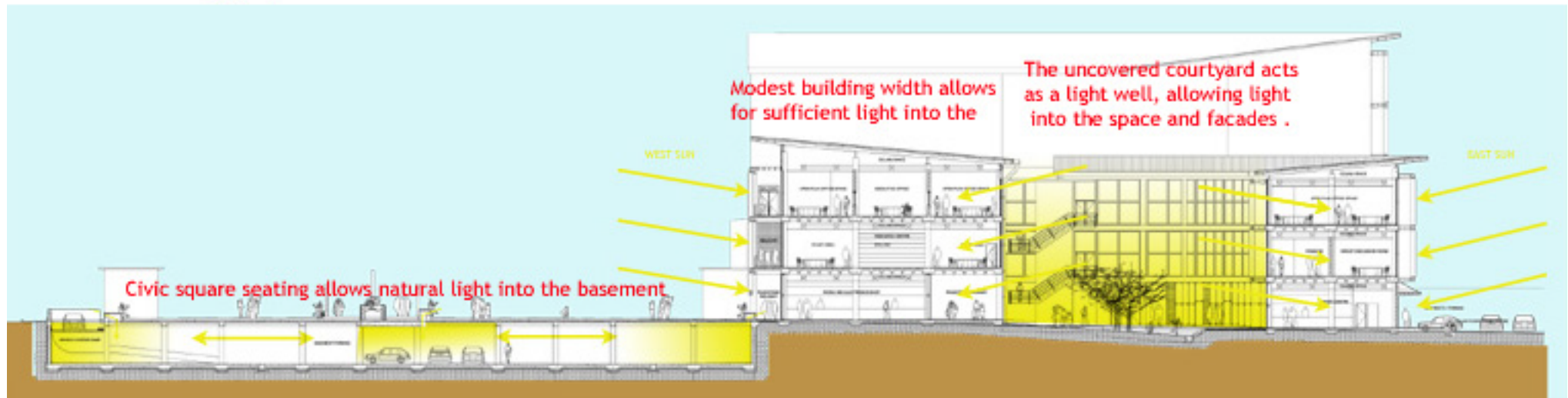

Section illustrating light penetration from the east and west.

## CLIMATE CONTROL

## HEATING AND VENTILATION

The design of the structure seeks to reduce the reliance on mechanical ventilation by exploring means of passive cooling. The inclusion of screens and louvres helps keep the heat load low, thus alleviating the need for mechanical ventilation. Glazing used in the office space, restaurants and resource centre has opening sections that induce cross ventilation.

The site experiences east-south-easterly and east-north-easterly summer winds, and south westerly and north easterly winter winds. The wind direction in both seasons offers possibilities of cross ventilation.

In addition to passive means, two aircon plant rooms are located at opposite ends in the basement of the structure. Each with its own feeder duct throughout the entire height of the structure, that feeds airconditioned air to each of the floors.

The Capital Project Application (CPA) air handling unit (AHU) system is employed to distribute the airconditioned air.

The basement parking is ventilated by means of air intakes and vehicle entrance that are positioned on one side, and extractor fans that expel the air on the opposite end of the basement.

Heating is provided throughout the structure when necessary by adjusting the temperature of the airconditioning the system.

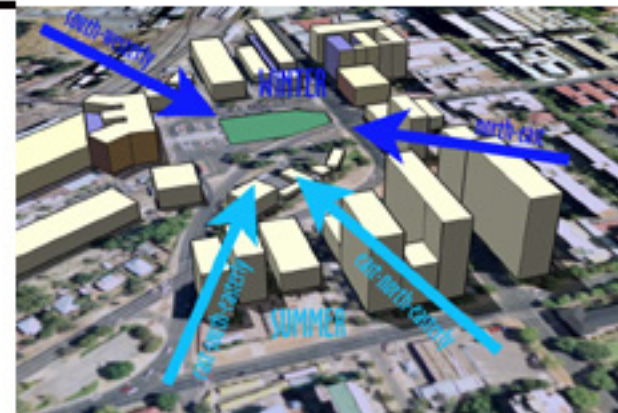

Wind directions for the site

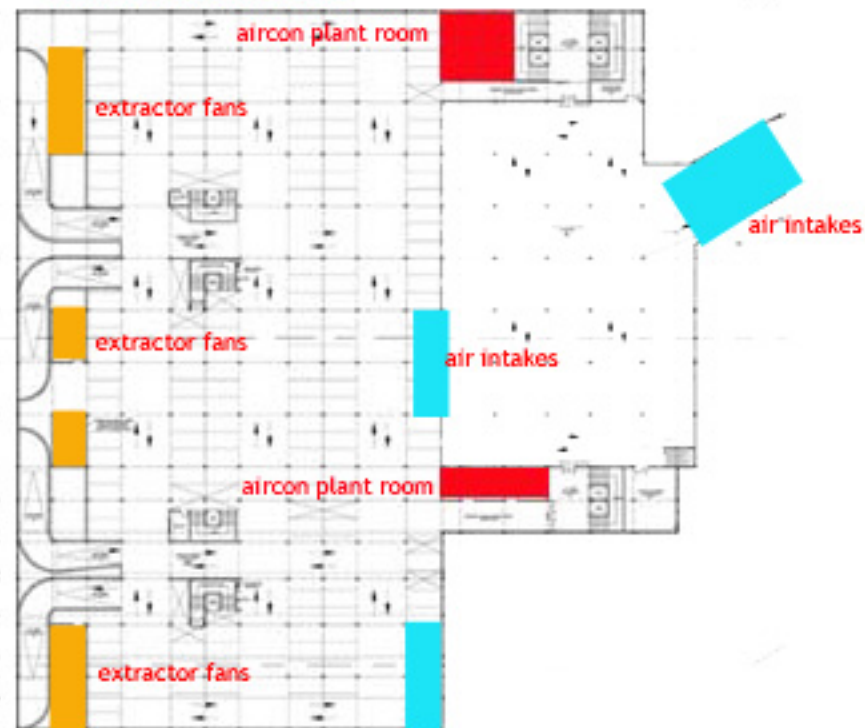

Basement plan illustration the aircon plant rooms



# CLIMATE CONTROL

## HEATING AND VENTILATION



Positioning of Aircon ducts in subsequent floor levels

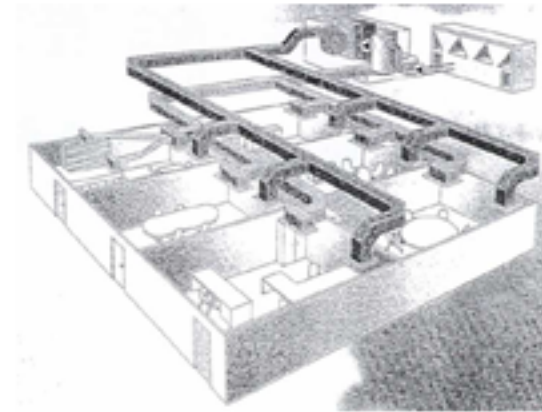

Typical Daikin AH unit (Daikin Manual)

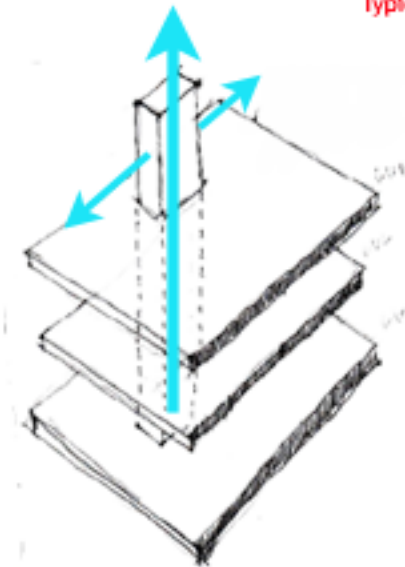

Duct penetration extract and air supply

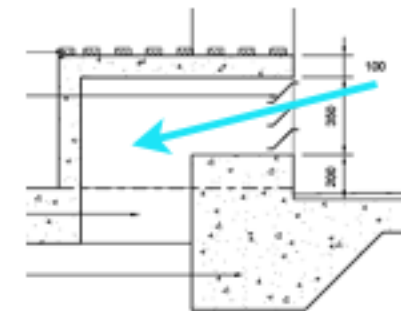

Basement air inlet detail

# CLIMATE CONTROL

## HEATING AND VENTILATION

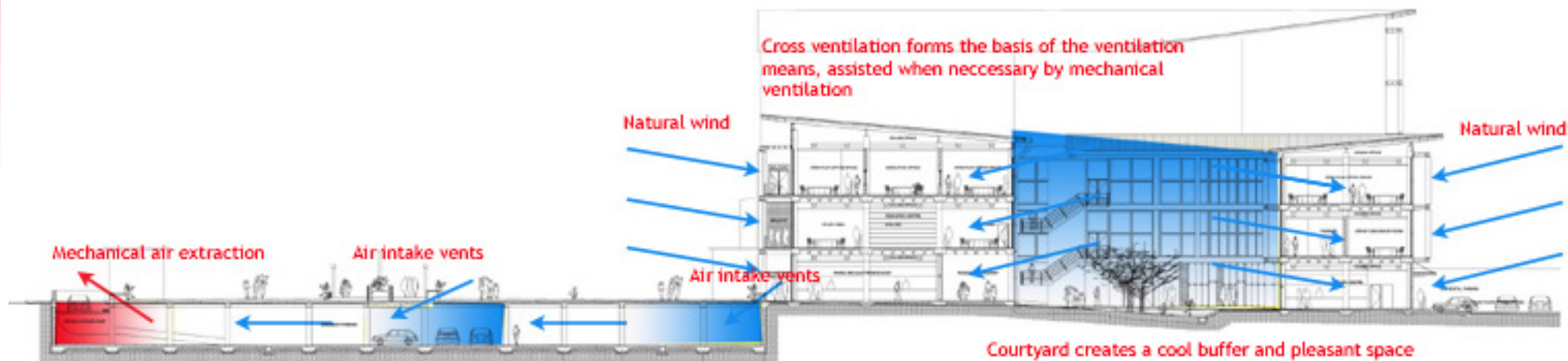

Section illustrating ventilation methods

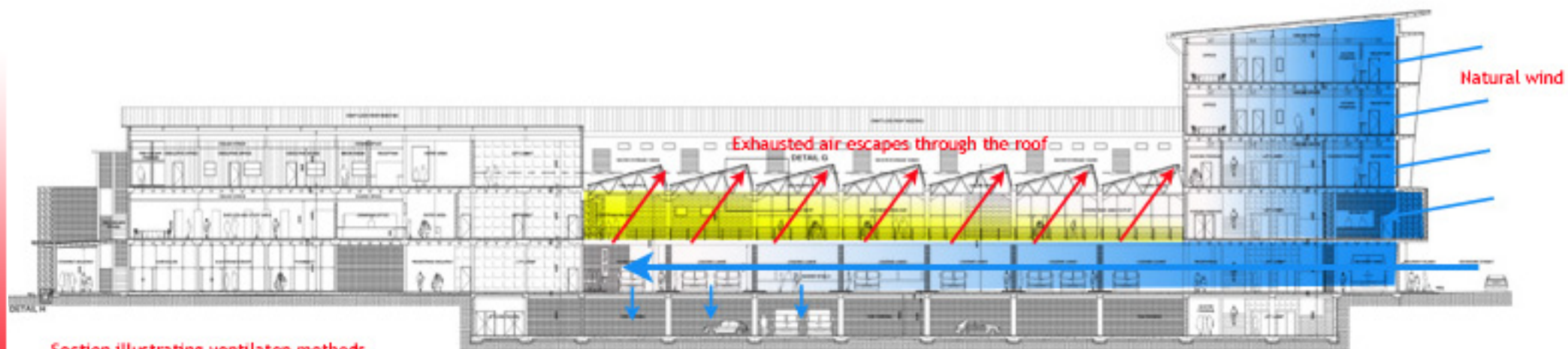

Section illustrating ventilaton methods

## STORMWATER DISPOSAL

## RAINWATER TREATMENT

All eaves on the run-off side of the roof are fitted with gutters and downpipes to channel water either into the stormwater drains, or storage tanks for taxi washing. Diameter 150mm uPVC downpipes are fitted inside the RHS columns and discharge into stormwater drains where there is covered walkways. The street walkway along Railway street allows the water to drip from the gutter into a stormwater drain below, without a downpipe.

The stormwater drains have access point along its length at intervals not exceeding 40m, in compliance with SABS 0400 (1990) Part R.

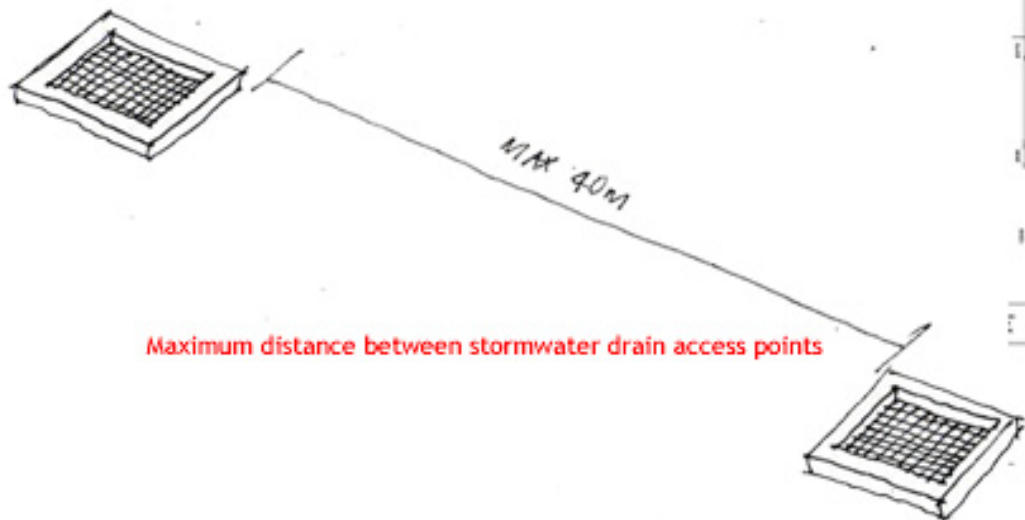
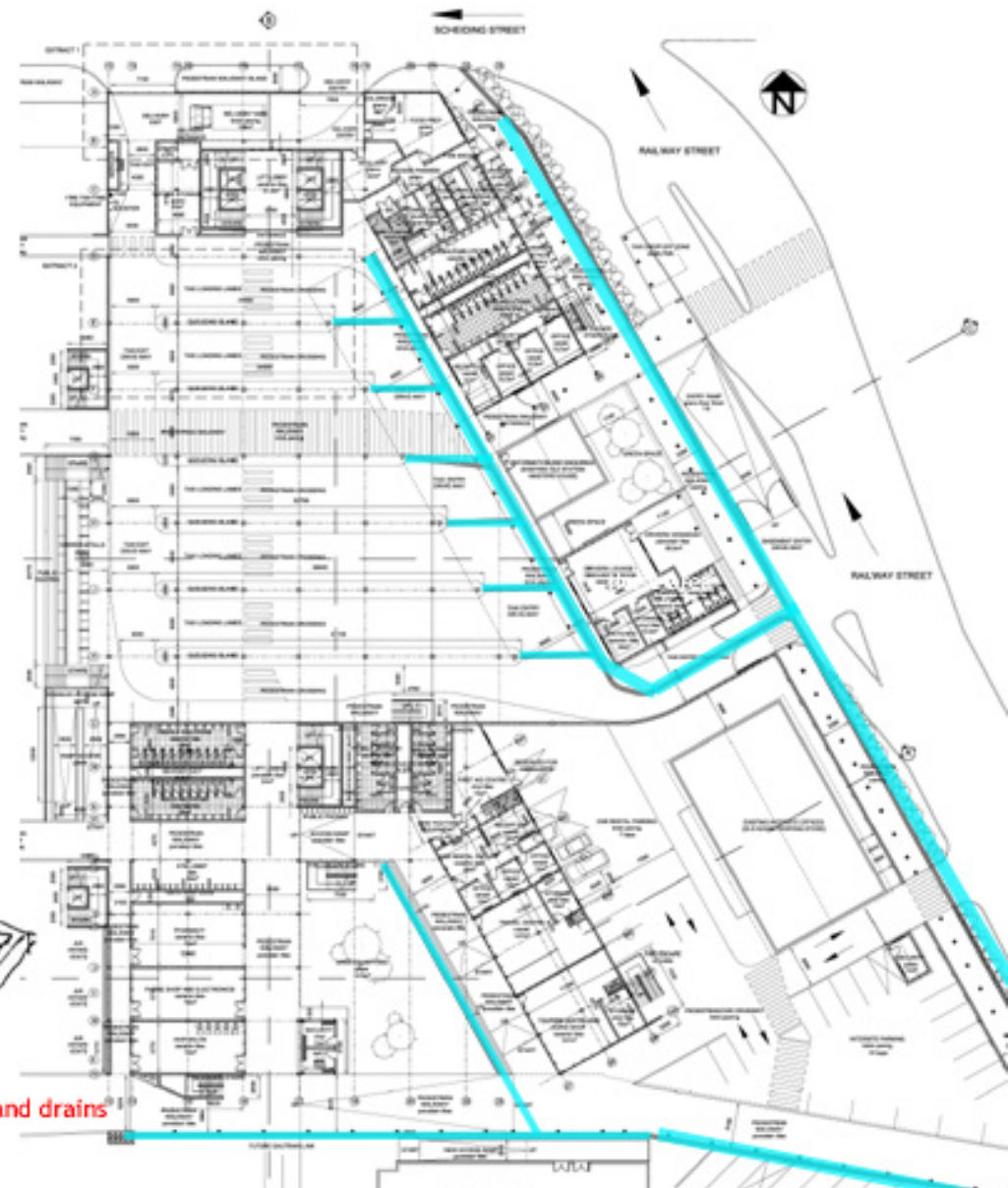

Maximum distance between stormwater drain access points

Location of stormwater channels and drains

### STORMWATER DISPOSAL

#### RAINWATER TREATMENT

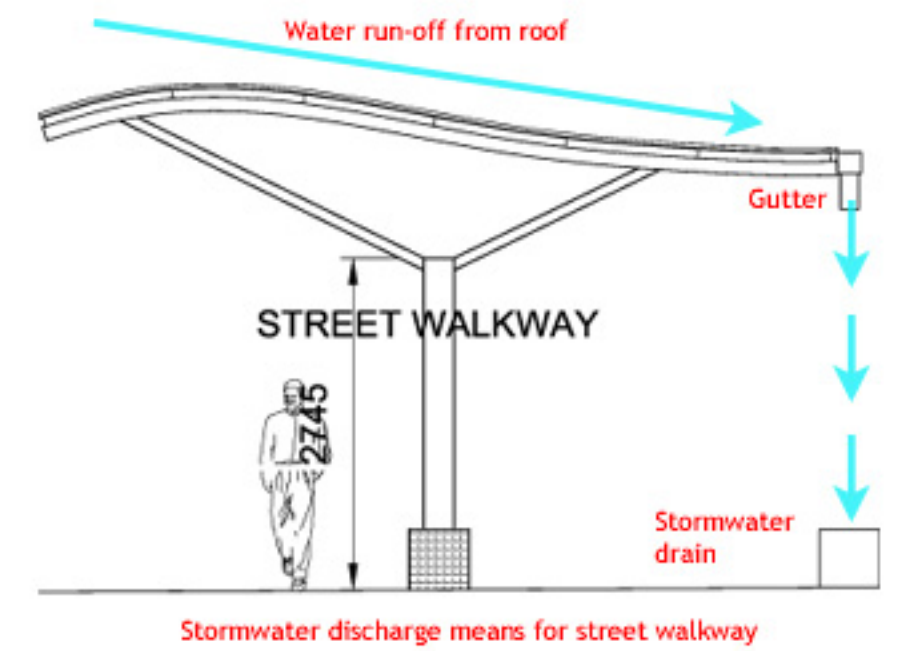
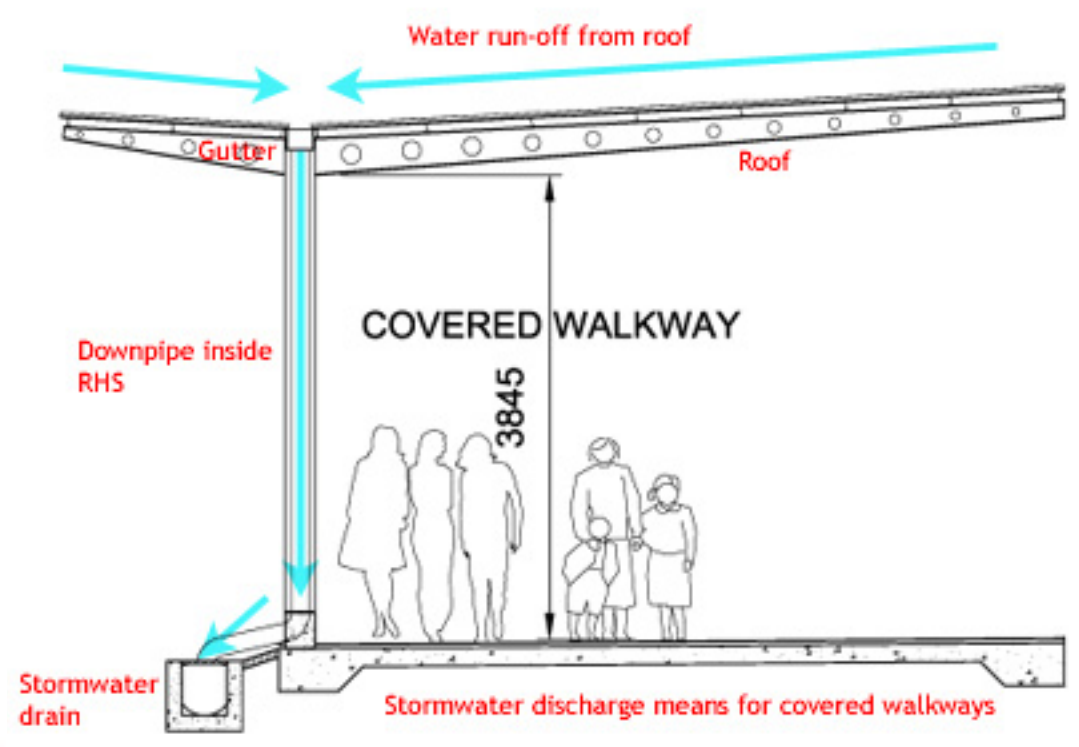

STORMWATER DISPOSAL

RAINWATER TREATMENT

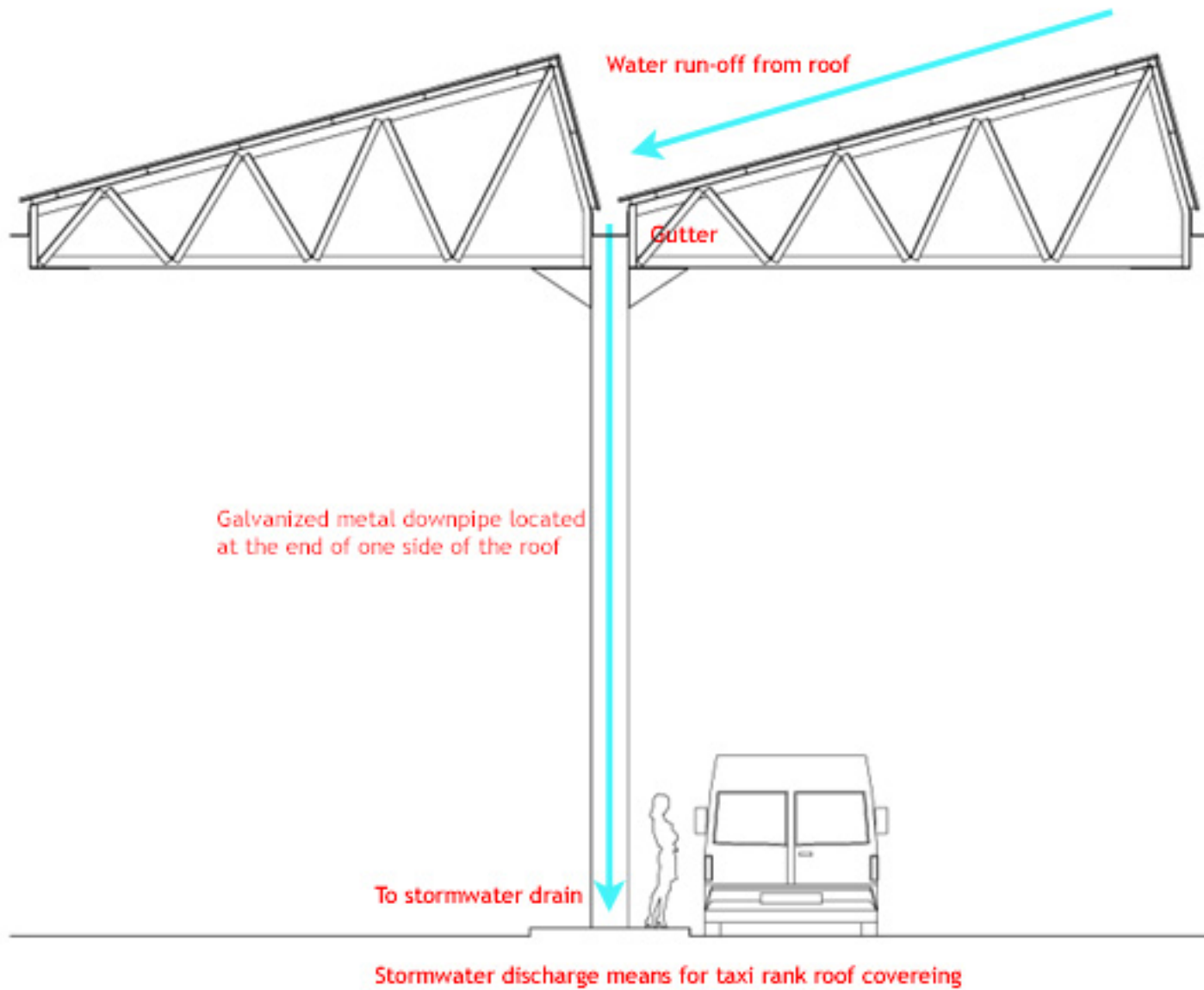

## VERTICAL CIRCULATION

### LIFTS, STAIRS AND RAMPS

The structure is designed such that the ground and first floor are the main public spaces. The levels above those are semi-private. Vertical circulation between the ground and first floor is by means of lifts, stairs and ramps. However, from the first floor to the top floor, only lifts and stairs service people. For the convenience of the employees, two express lifts run non-stop from the basement up to the first level of offices.

Disabled people are provide for through a ramp with a slope of 1:12 and a width of 2m to allow two people to pass in opposite directions.

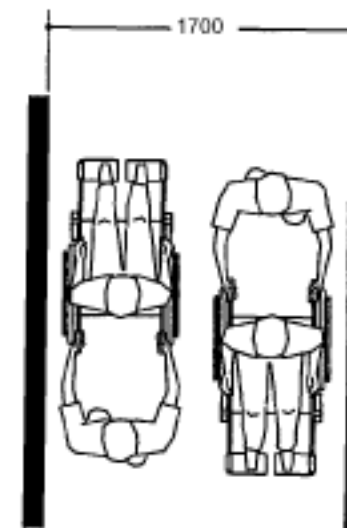

Dimensions for two disable people passing alongside  
(Metric handbook planning and design data)

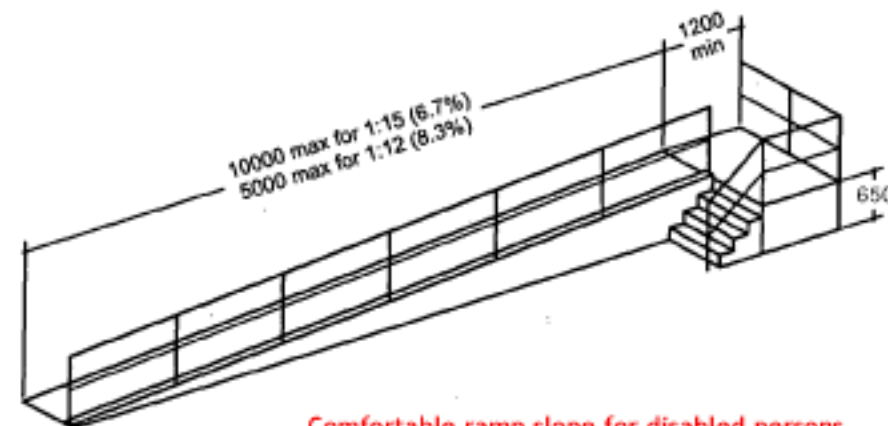

Comfortable ramp slope for disabled persons  
(Metric handbook planning and design data)

## VERTICAL CIRCULATION

## LIFTS, STAIRS AND RAMPS



Positioning of vertical circulation on plan  
(Metric handbook planning and design data)

VEHICLE ANALYSIS

DIMENSIONS AND TURNING ANGLES

A thorough understanding of the dimension and turning angles for taxis, delivery vehicles and refuse collection vehicle is necessary in order to design for the spaces accordingly.

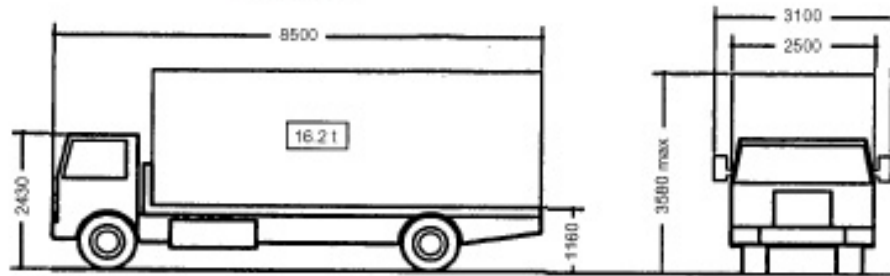

Dimensions for a delivery truck (Metric handbook planning and design data)

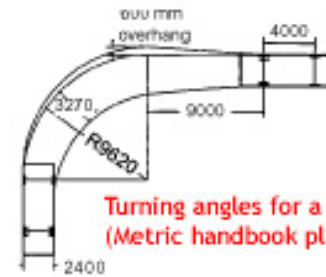

Turning angles for a delivery truck (Metric handbook planning and design data)

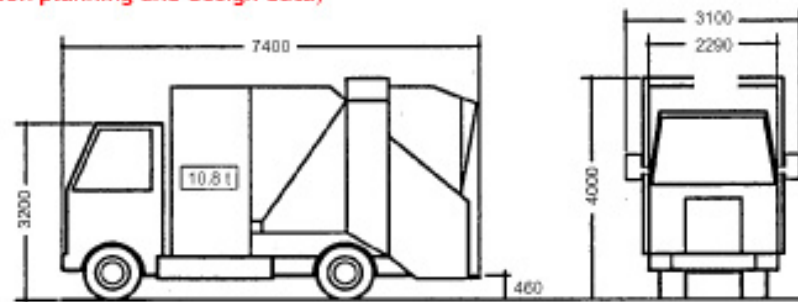

Refuse truck (Metric handbook planning and design data)



Dimensions for a Mercedes Sprinter taxi (largest taxi)



VEHICLE ANALYSIS

DIMENSIONS AND TURNING ANGLES

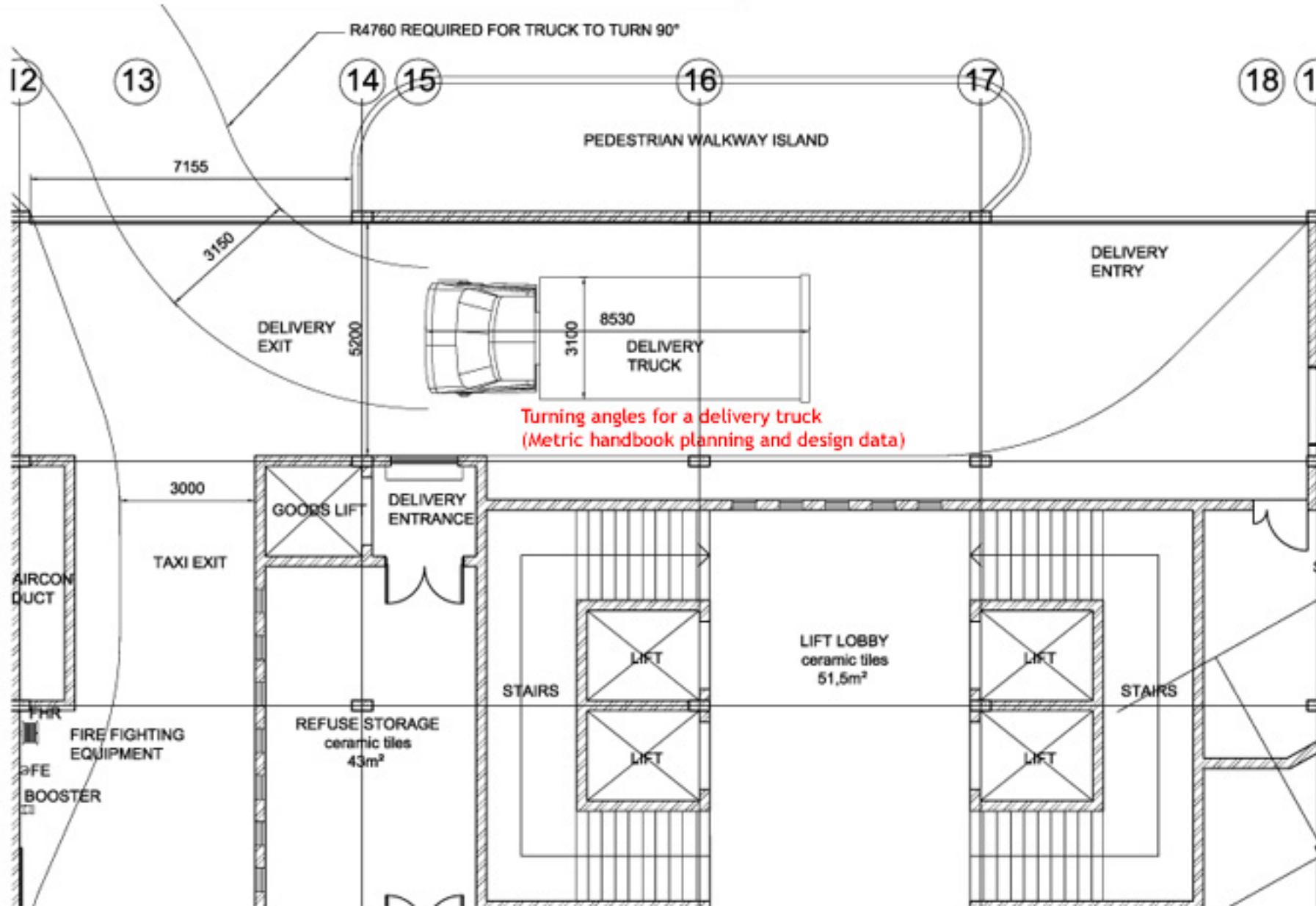

## VEHICLE ANALYSIS

## DIMENSIONS AND TURNING ANGLES

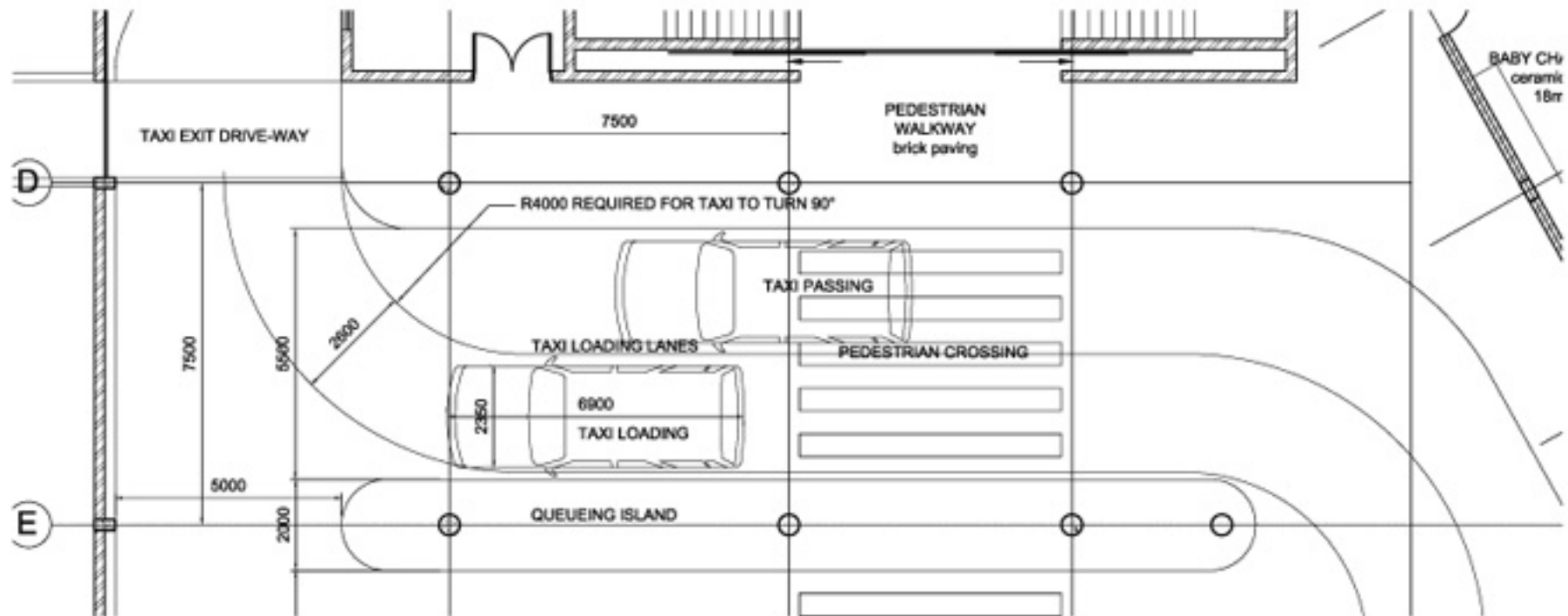

Turning angles for the largest taxi (Sprinter)  
 (Metric handbook planning and design data)

## ABLUTION SERVICES

### MALE AND FEMALE ABLUTION SERVICES

The mixed-use structure can be classified under the following occupancy classes:

- A3-Resource centre
- C1 & C2-Exhibition hall and Museum
- D4-Plant room
- F2-Small shop
- G1-Offices
- J4-Parking garage

SABS 0400 (1990) table 4 and 6 outline the provision of sanitary fixtures for the classes in question.

The location of the ablutment points in plan is dictated ease of by accessibility, the idea is to have the ablutments as centrally placed as possible. The design is such that the male and female ablutments are back to back with a duct in between to conceal the service pipes, and also to afford maintenance access.

1	2	3	4	5	6
For a population of up to —	Number of sanitary fixtures to be installed relative to the population given in Column 1				
	Males			Females	
	WC pans	Urinals	Washbasins	WC pans	Washbasins
15	1	1	1	2	1
30	1	2	2	3	2
60	2	3	3	5	3
90	3	5	4	7	4
120	3	6	5	9	5
	For a population in excess of 120 add 1 WC pan, 1 urinal and 1 washbasin for every 100 persons			For a population in excess of 120 add 1 WC pan for every 50 persons	For a population in excess of 120 add a washbasin for every 100 persons

Table 6 [SABS 0400 (1990)]

ABLUTION SERVICES

MALE AND FEMALE ABLUTION SERVICES

1 Type of occupancy and population	2 Fixture	3 Exceptions
A1: Personnel Public and visitors	Table 6 Males: 1 WC pan 1 washbasin Females: 1 WC pan 1 washbasin	<p>a) In any building where facilities in accordance with Table 5 are available to both personnel and the public or visitors, no separate facilities shall be required for the public or visitors.</p> <p>b) No separate facilities for the public or visitors shall be required within any shop having a floor area of less than 50 m<sup>2</sup>.</p> <p>c) In any group of shops under one ownership or in any shopping complex on a single site –</p> <p>i) facilities for personnel may be situated at convenient locations and not necessarily in any particular shop or shops;</p> <p>ii) facilities for personnel may be grouped or combined with those provided for the use of the public or visitors.</p> <p>d) In any occupancy where personnel are exposed to high risk substances, dirt, sm, dust, soot, oil, grease or any similar substance, exposure to which is such that showers are necessary, at least 1 shower per 15 persons shall be provided separately for each sex and such showers shall be located in, or have direct access to, a change room.</p>
A2: Personnel Public and visitors Peak demand No peak demand Participants in sports	Table 6 Table 7 (part a) Table 7 (part b) Table 8	
A3	Table 6	
A4: Personnel Public and visitors	Table 6 Males: 1 WC pan 1 washbasin Females: 1 WC pan 1 washbasin	
A5: Public and visitors Peak demand No peak demand Participants in sport	Table 7 (part a) Table 7 (part b) Table 8	
B1, B2 and B3 Personnel Public and visitors	Table 6 1 WC pan 1 washbasin	
C1 and C2 Personnel Public and visitors	Table 6 Males: 1 WC pan 1 washbasin Females: 1 WC pan 1 washbasin	
D1, D2 and D3 Personnel Public and visitors	Table 6 No separate provision required No provision required	
D4	Table 6	
F1: Personnel Public and visitors	Table 6 Males: 1 WC pan 1 washbasin Females: 1 WC pan 1 washbasin	
F2 and F3 Personnel Public and visitors	Table 6 1 WC pan 1 washbasin	
G1: Personnel Public and visitors	Table 6 Males: 1 WC pan 1 washbasin Females: 1 WC pan 1 washbasin	

Table 4 [SABS 0400 (1990)]

**ABLUTION SERVICES**

**MALE AND FEMALE ABLUTION SERVICES**

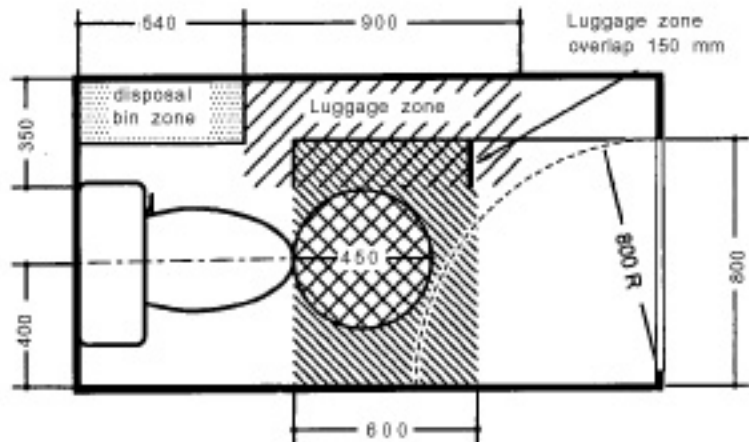

Typical size of WC cubicle with an inward opening door (Metric handbook planning and design data)

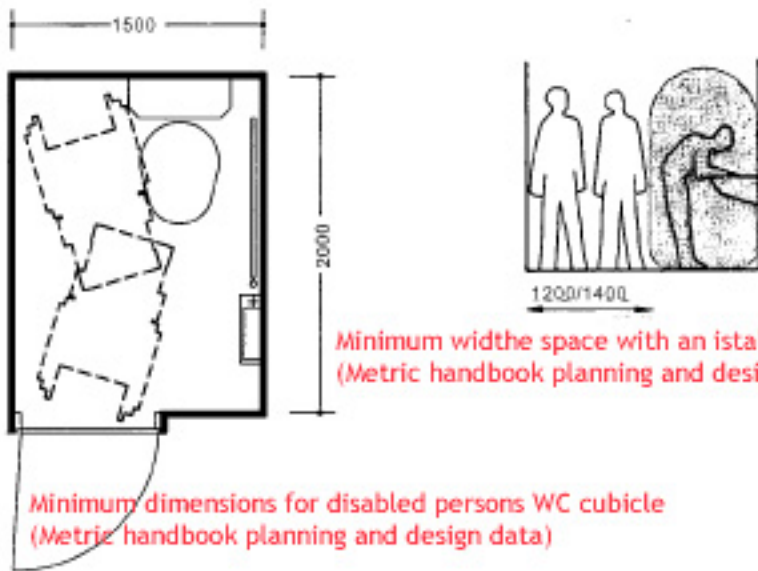

Minimum width space with an installation on one side (Metric handbook planning and design data)

Minimum dimensions for disabled persons WC cubicle (Metric handbook planning and design data)



Positioning of ablutions on plan

## FIRE PROVISION

## FIRE EQUIPMENT AND ESCAPE ROUTES

The building is designed to have two firefighting points with fire extinguishers, fire hose reel and fire hydrant. Main covered walkways have a clearance height of 5m and a width of 5m to allow emergency vehicles access.

Inside the structure, fire escape exits are located within a distance less than 30m from the furthest point along the escape route, in accordance to the SABS 0400 (1990) Part T.

Fire escape doors are provided for and the materials on the fire escape routes have a minimum fire resistance of 120 minutes.

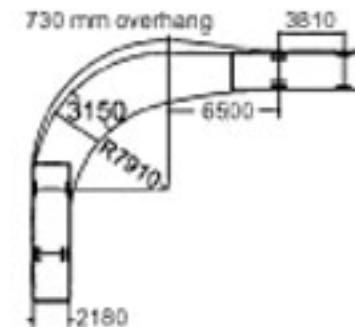

e fire appliance

Turning radius for a fire appliance (Metric handbook planning and design data)

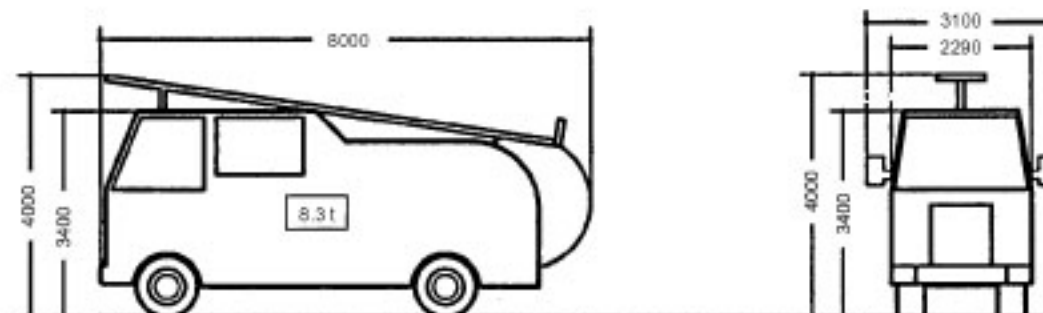

Dimensions for a medium size fire appliance (Metric handbook planning and design data)

# FIRE PROVISION

## FIRE EQUIPMENT AND ESCAPE ROUTES

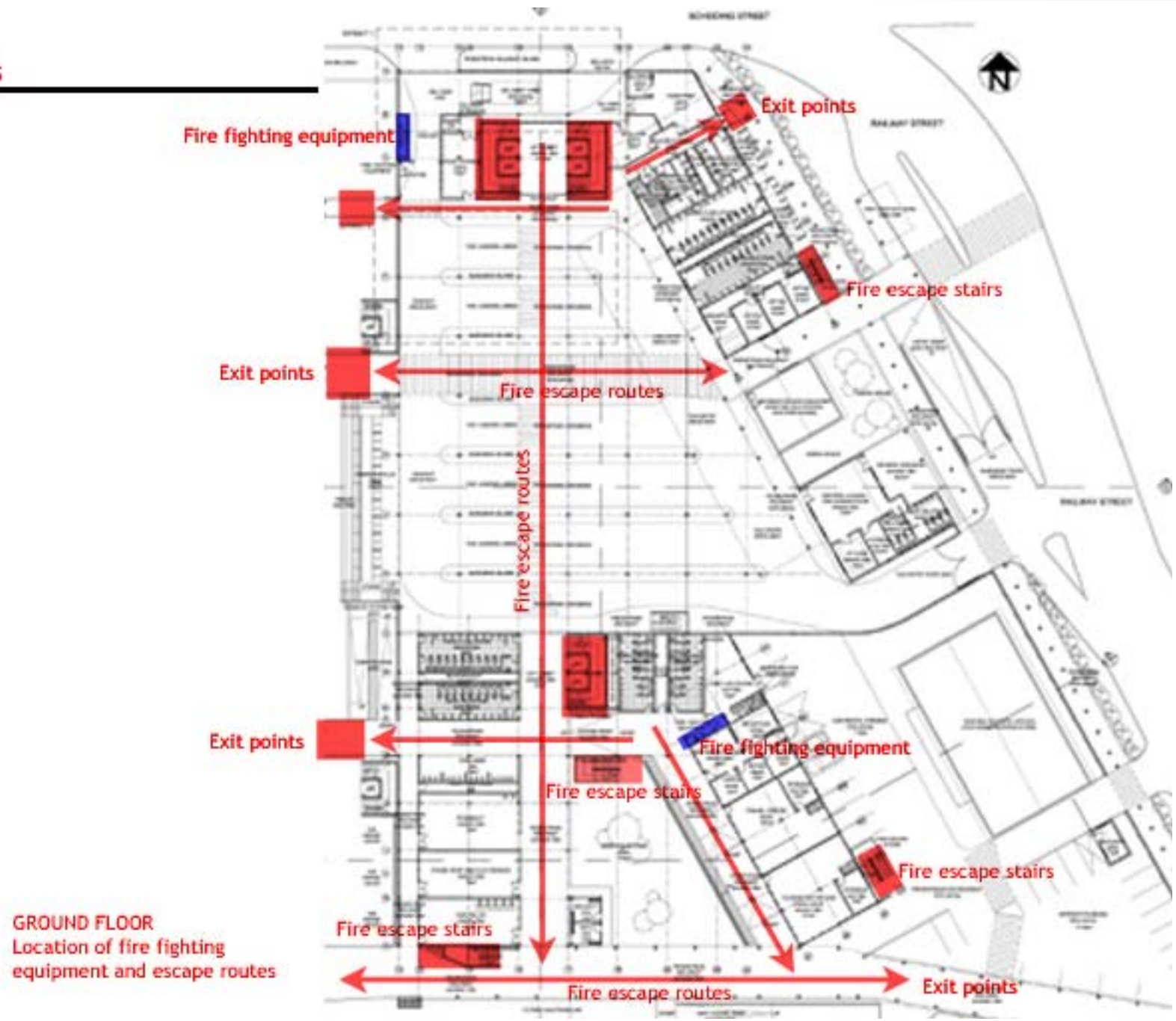

GROUND FLOOR  
Location of fire fighting  
equipment and escape routes

FIRE PROVISION

FIRE EQUIPMENT AND ESCAPE ROUTES

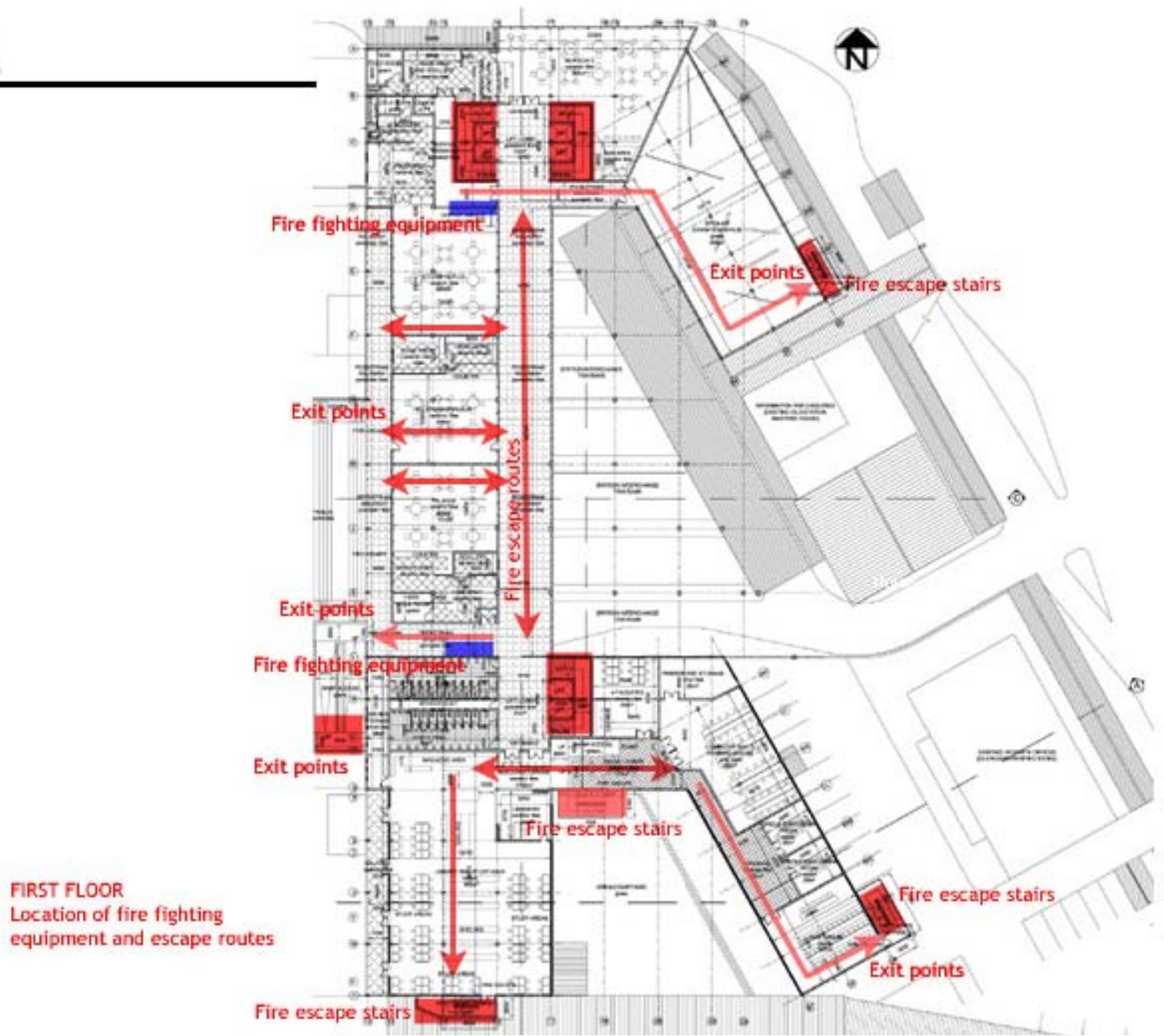

FIRST FLOOR  
Location of fire fighting  
equipment and escape routes



## *CHAPTER 5*

Page 148

# University of Pretoria etd, Tshombe MX (2007)

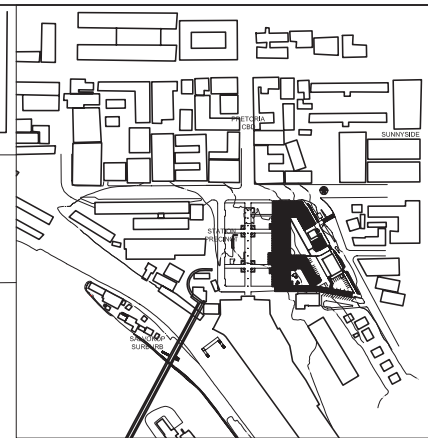
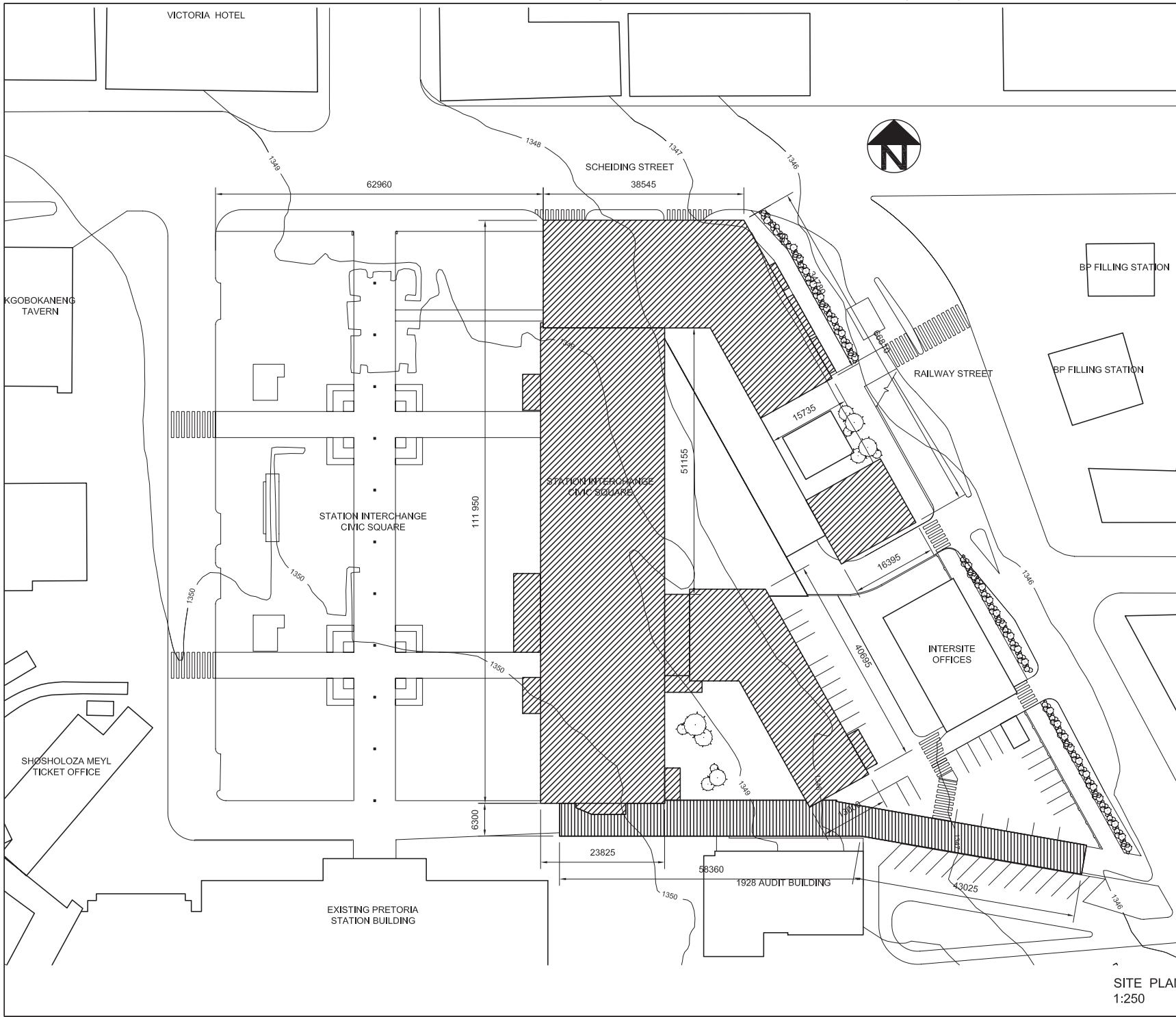

LOCALITY PLAN  
1:2500

SITE PLAN  
1:250

DATE: 29-11-2006	
PROJECT: STATION INTERCHANGE AND CIVIC SQUARE	
DESCRIPTION: LOCALITY AND SITE PLAN	
SCALE	1:250 / 1:2500
UNIVERSITY OF PRETORIA	
25317556	

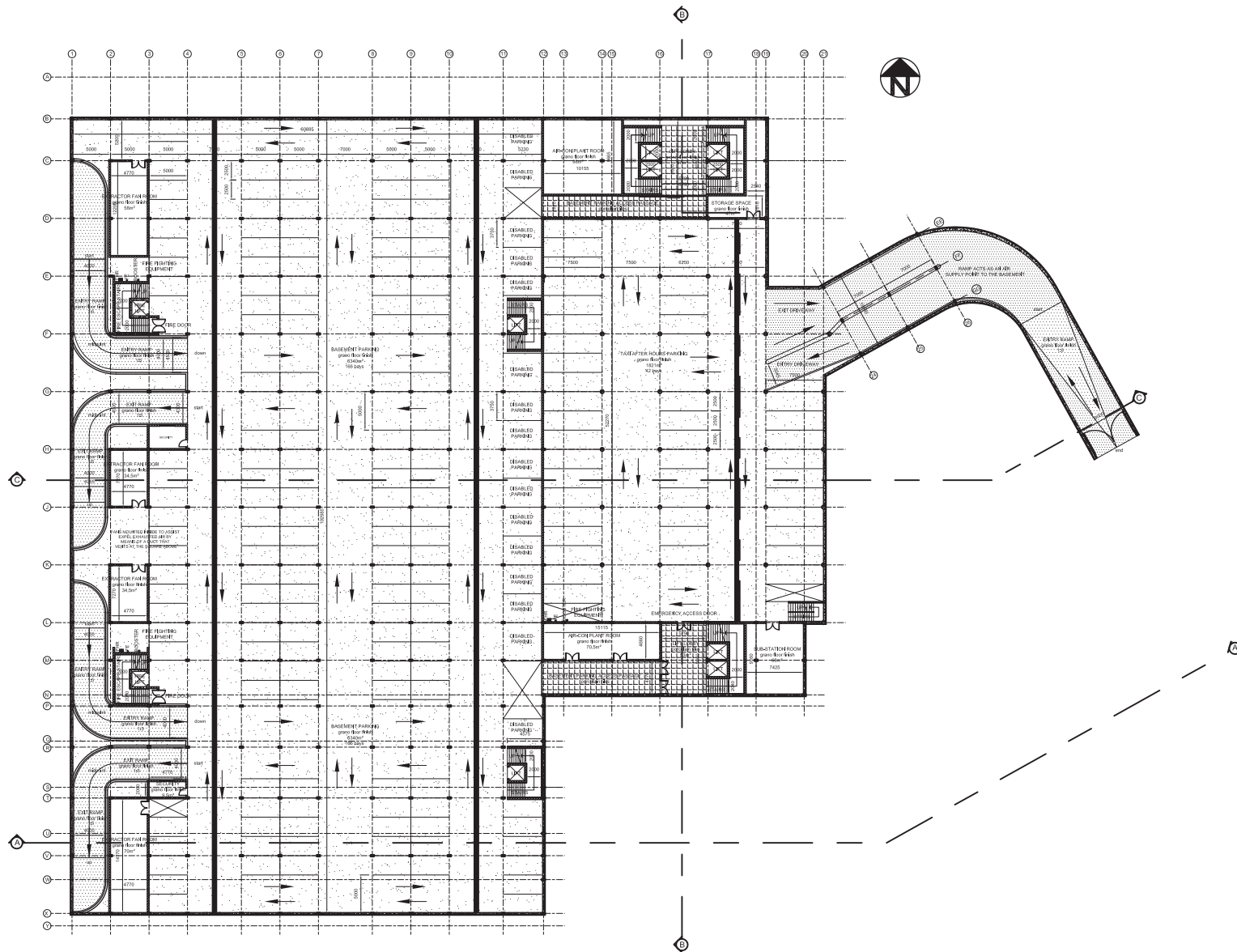

BASEMENT FLOOR PLAN  
1:200



DATE: 28-11-2006

PROJECT:  
STATION INTERCHANGE  
AND CIVIC SQUARE

DESCRIPTION:  
BASEMENT PLAN

SCALE 1:200

UNIVERSITY OF PRETORIA  
25317556

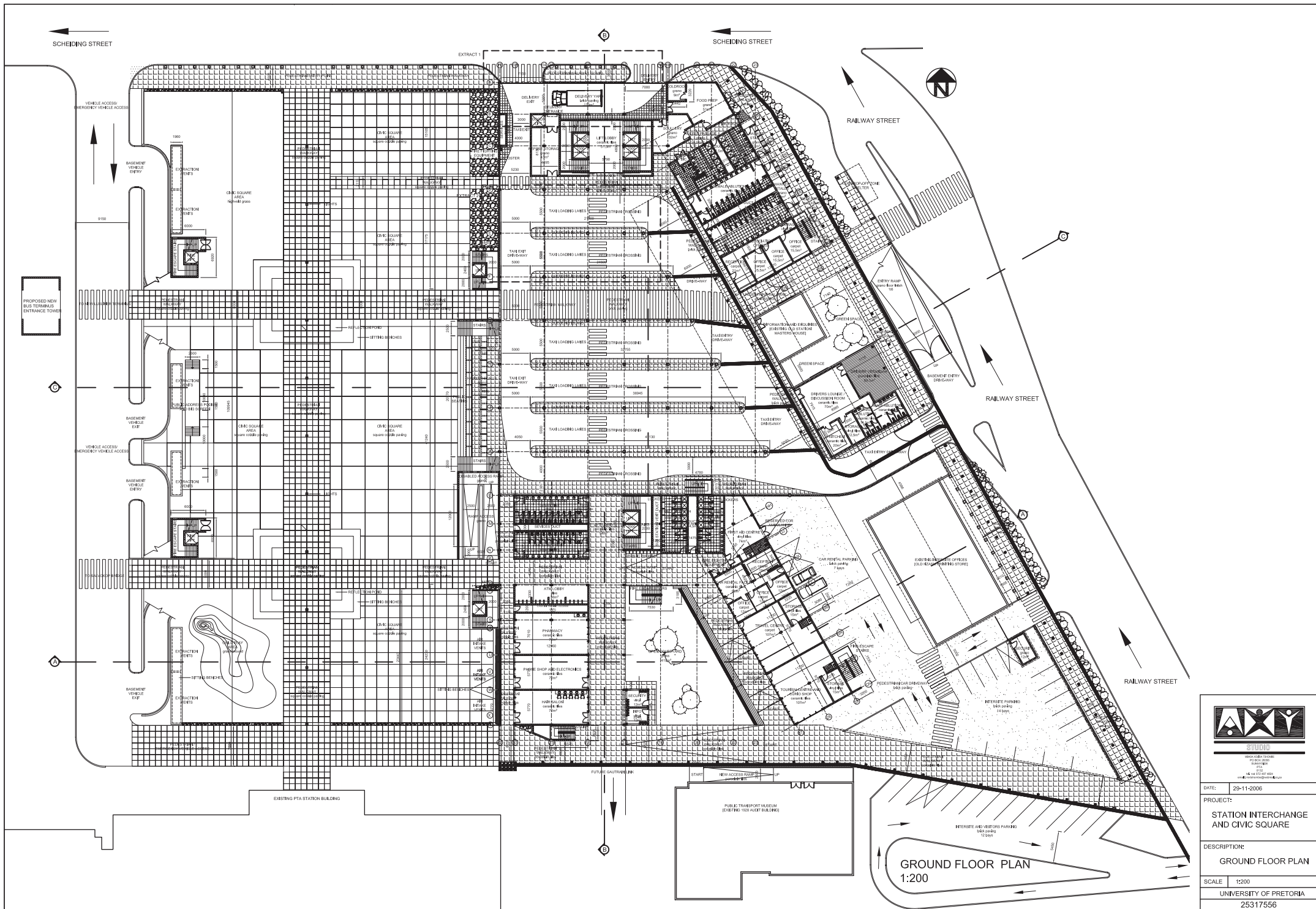

GROUND FLOOR PLAN  
1:200



UNIVERSITY OF PRETORIA  
ARCHITECTURE  
14, DE WET STREET  
PRETORIA 0001

DATE: 29-11-2006  
PROJECT: STATION INTERCHANGE AND CIVIC SQUARE  
DESCRIPTION: GROUND FLOOR PLAN  
SCALE: 1:200  
UNIVERSITY OF PRETORIA  
25317556

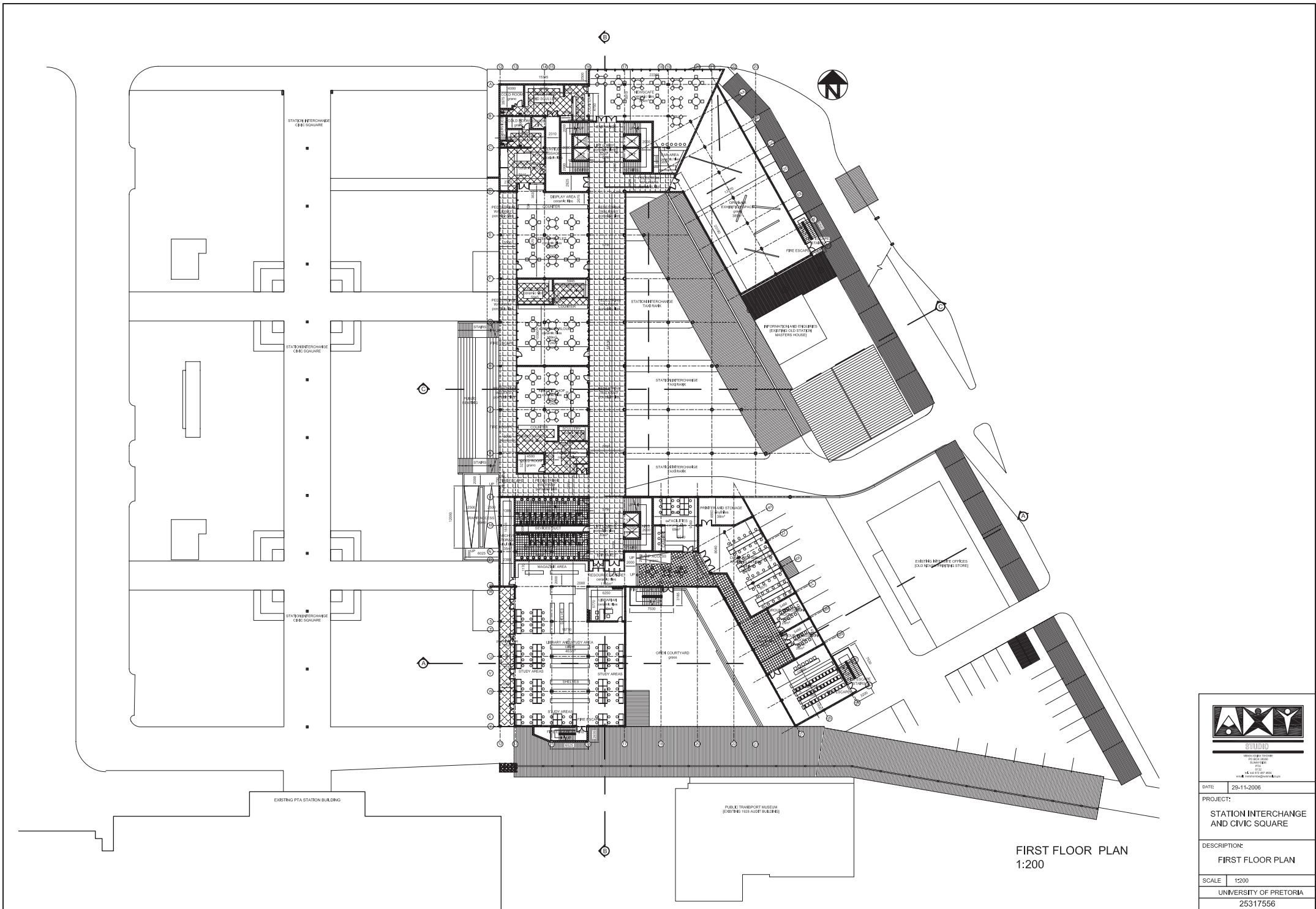

FIRST FLOOR PLAN  
1:200

	
DATE: 23-11-2006	
PROJECT: STATION INTERCHANGE AND CIVIC SQUARE	
DESCRIPTION: FIRST FLOOR PLAN	
SCALE:	1:200
UNIVERSITY OF PRETORIA 25317556	

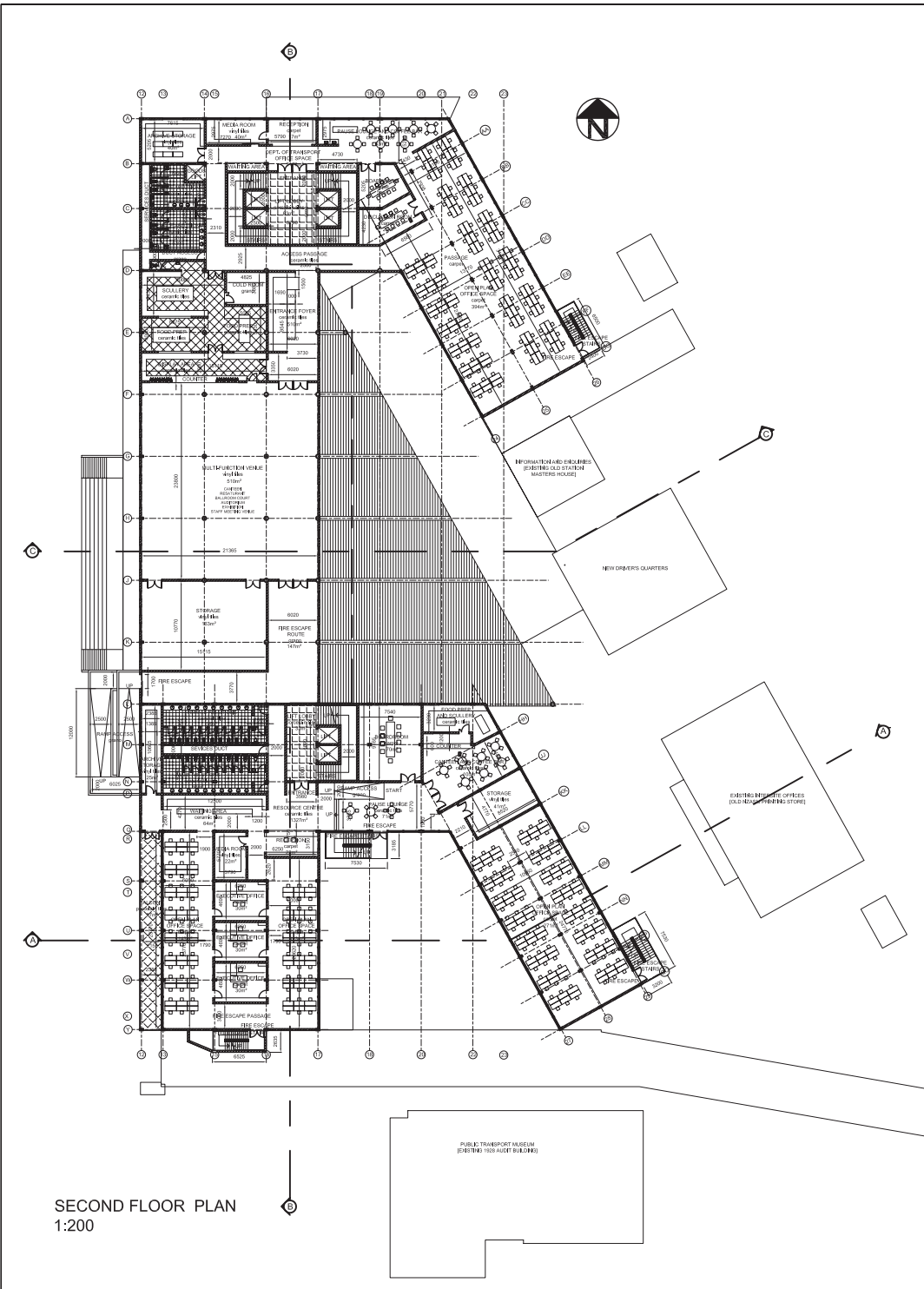

SECOND FLOOR PLAN  
1:200

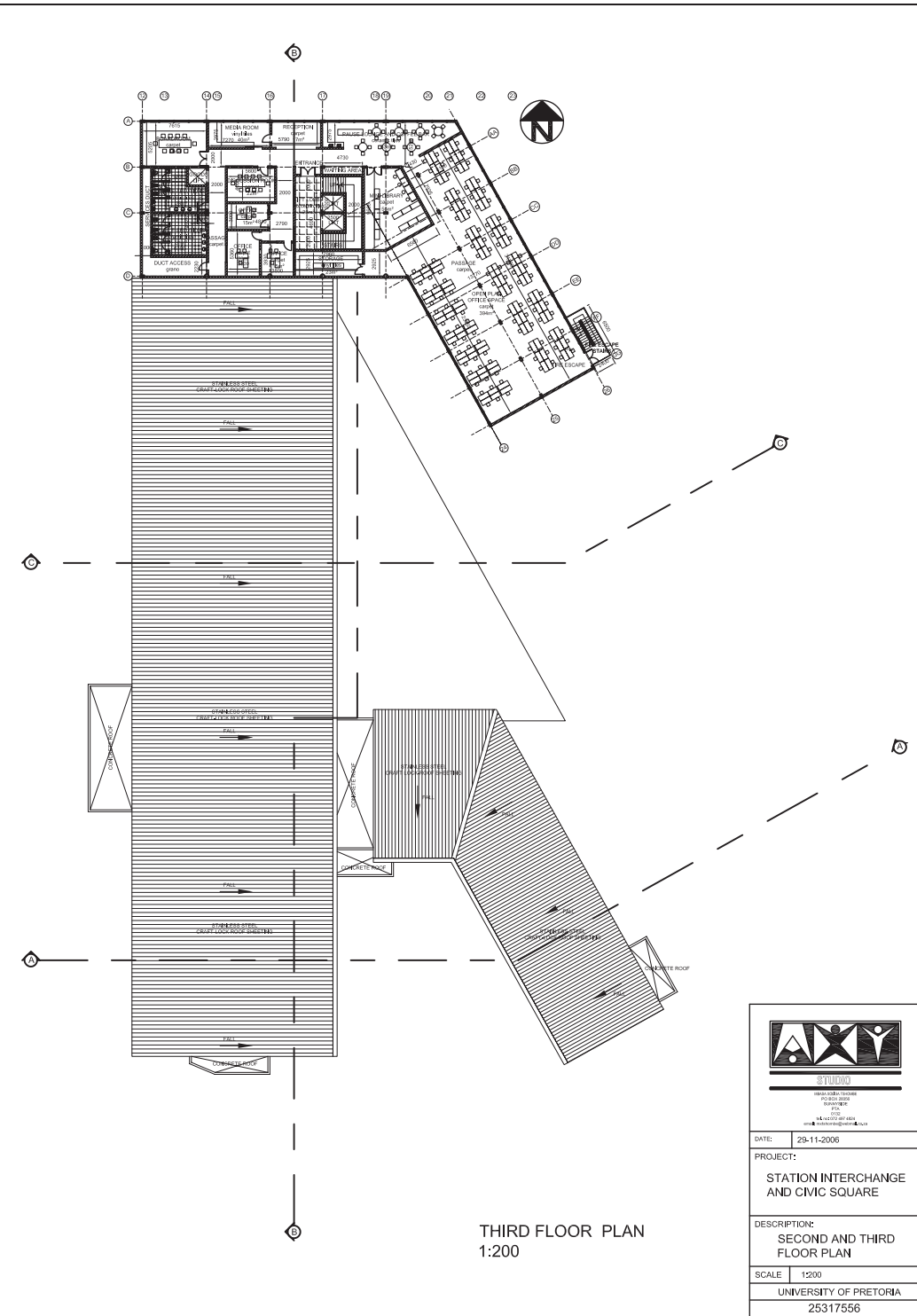

THIRD FLOOR PLAN  
1:200

UNIVERSITY OF PRETORIA  
ARCHITECTURE  
DEPARTMENT  
2007  
25317556

DATE: 29-11-2006

PROJECT:  
STATION INTERCHANGE  
AND CIVIC SQUARE

DESCRIPTION:  
SECOND AND THIRD  
FLOOR PLAN

SCALE: 1:200

UNIVERSITY OF PRETORIA  
25317556

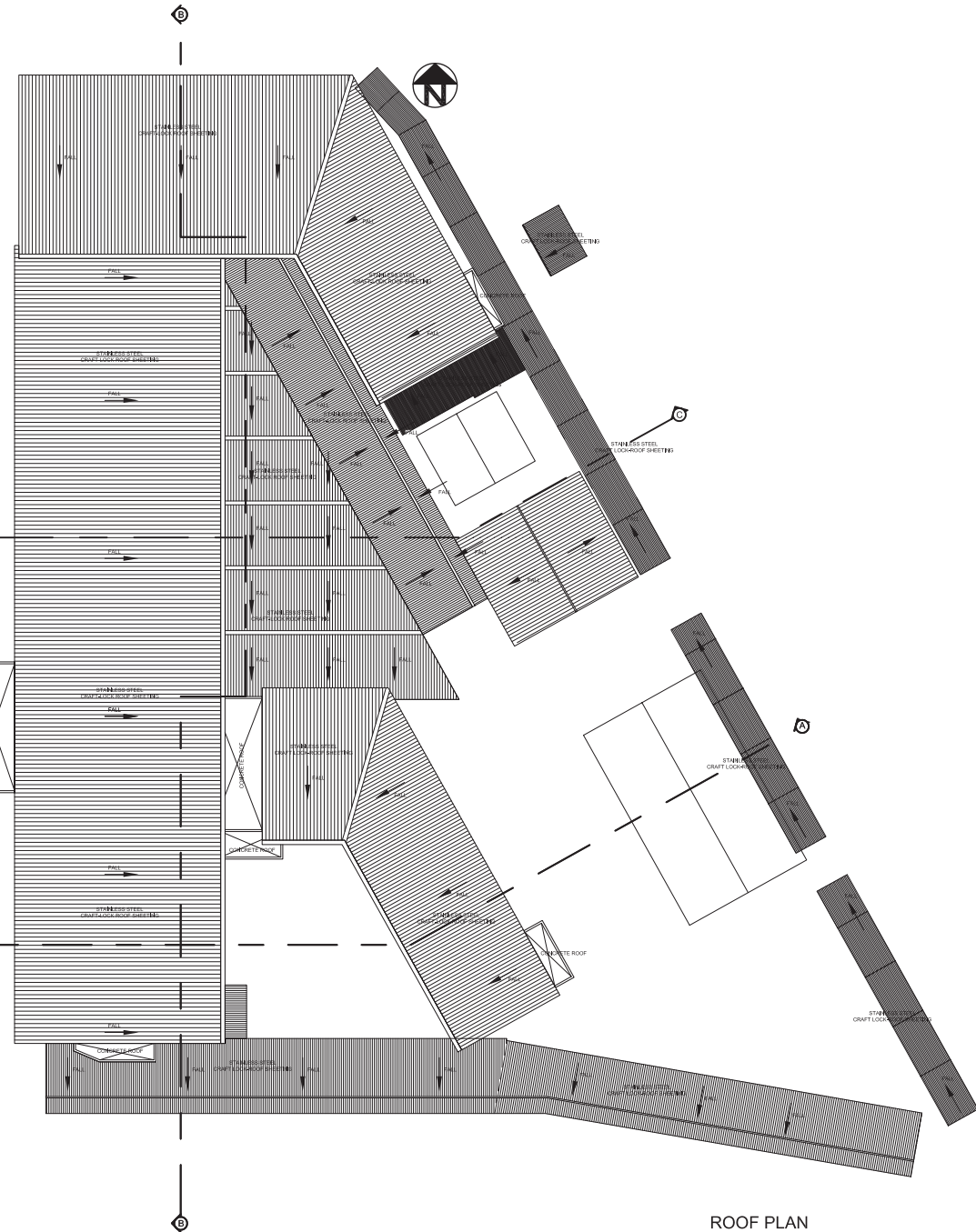
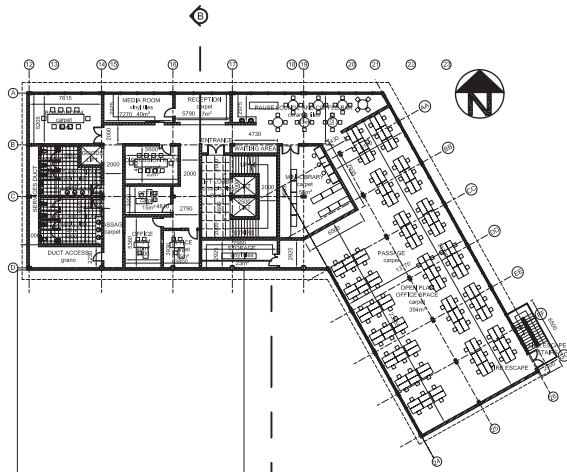

FOURTH FLOOR PLAN  
1:200

ROOF PLAN  
1:200



DATE:	29-11-2006
PROJECT:	STATION INTERCHANGE AND CIVIC SQUARE
DESCRIPTION:	FOURTH FLOOR AND ROOF PLAN
SCALE:	1:200
UNIVERSITY OF PRETORIA	
25317556	

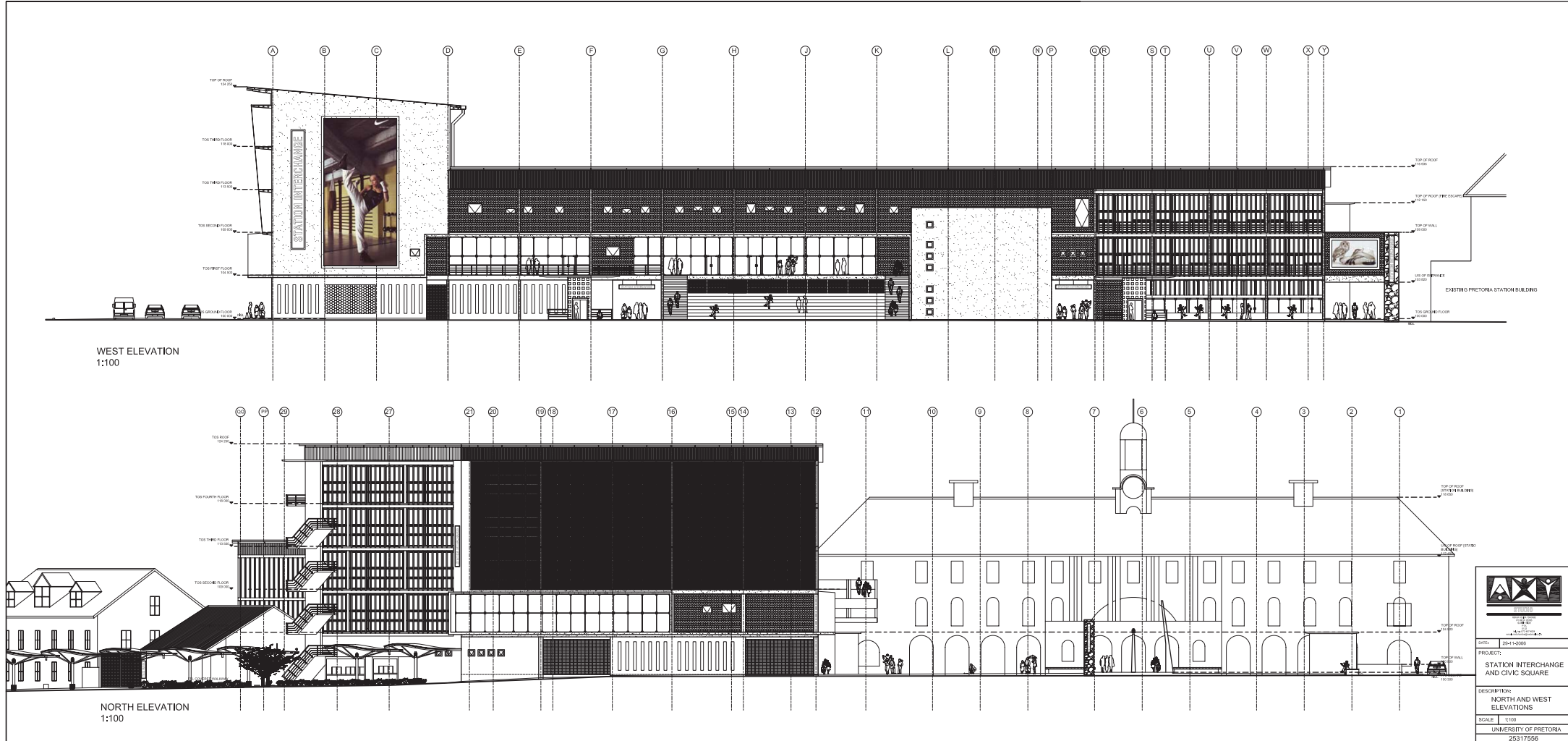

WEST ELEVATION  
1:100

NORTH ELEVATION  
1:100

 UNIVERSITY OF PRETORIA SCHOOL OF ARCHITECTURE	
DATE:	2004-10-06
PROJECT:	STATION INTERCHANGE AND CIVIC SQUARE
DESCRIPTION:	NORTH AND WEST ELEVATIONS
SCALE:	1:100
UNIVERSITY OF PRETORIA	25317556





EAST ELEVATION  
1:100

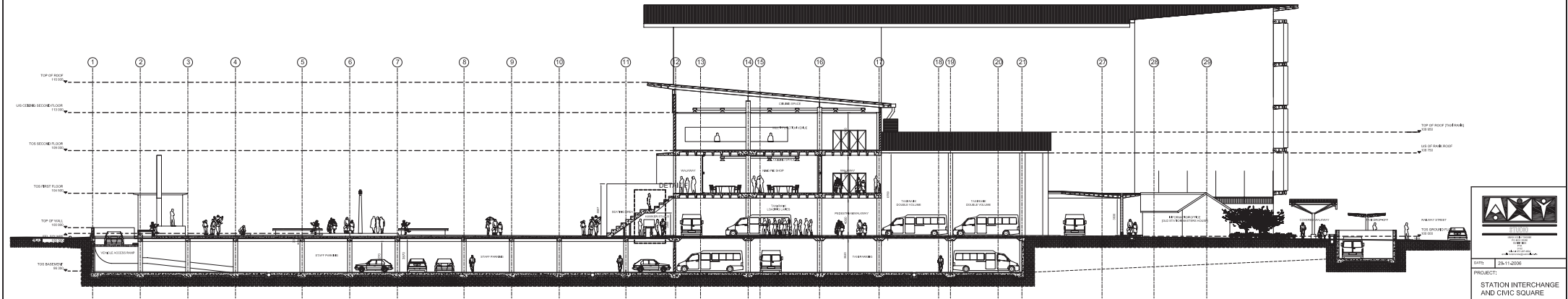

SECTION C-C  
1:100

	
2011-2009 UNIVERSITY OF PRETORIA ARCHITECTURE	
DATE: 26/11/2009 PROJECT: STATION INTERCHANGE AND CIVIC SQUARE	
DESCRIPTION: EAST ELEVATION AND SECTION C-C	
SCALE: 1:100 UNIVERSITY OF PRETORIA 25317568	

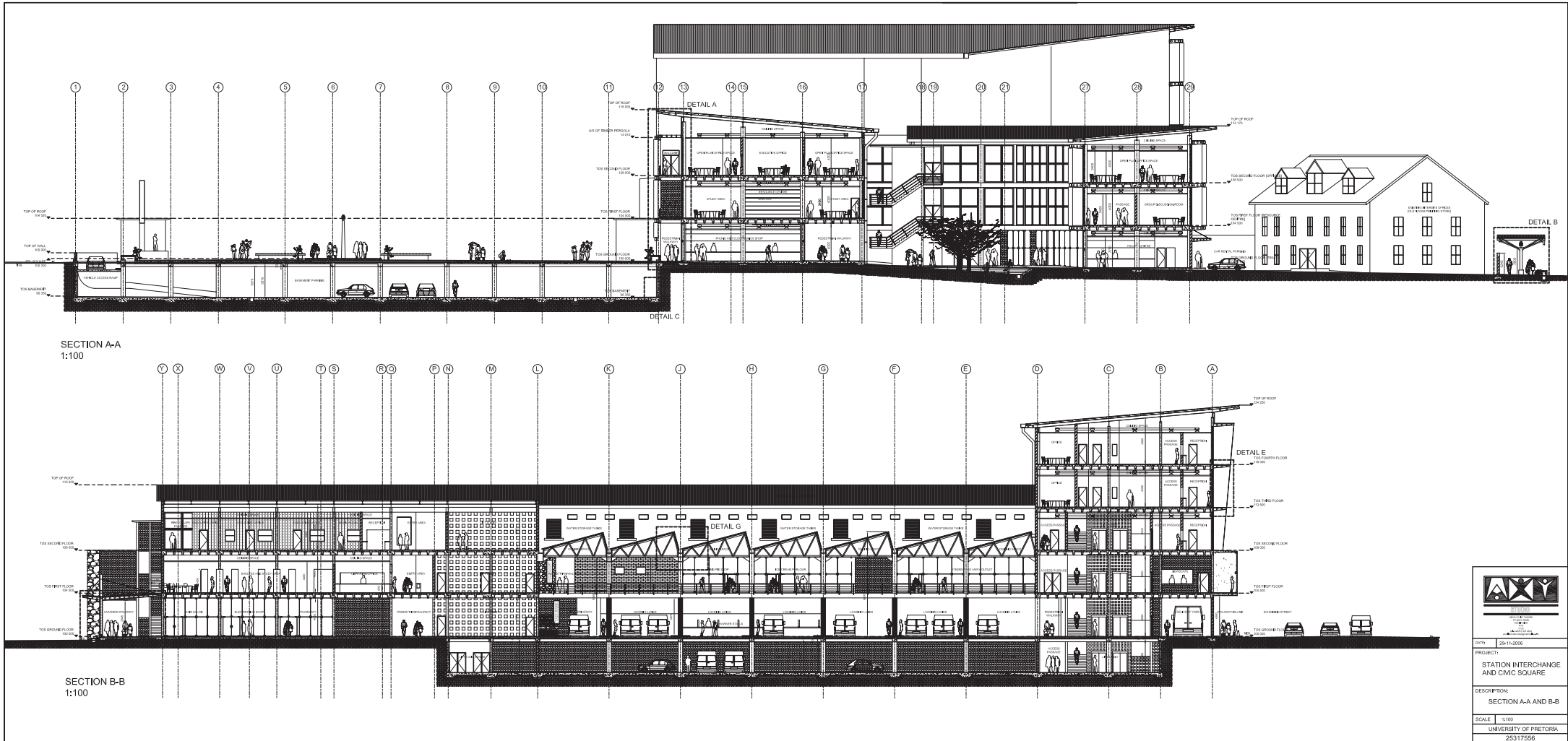

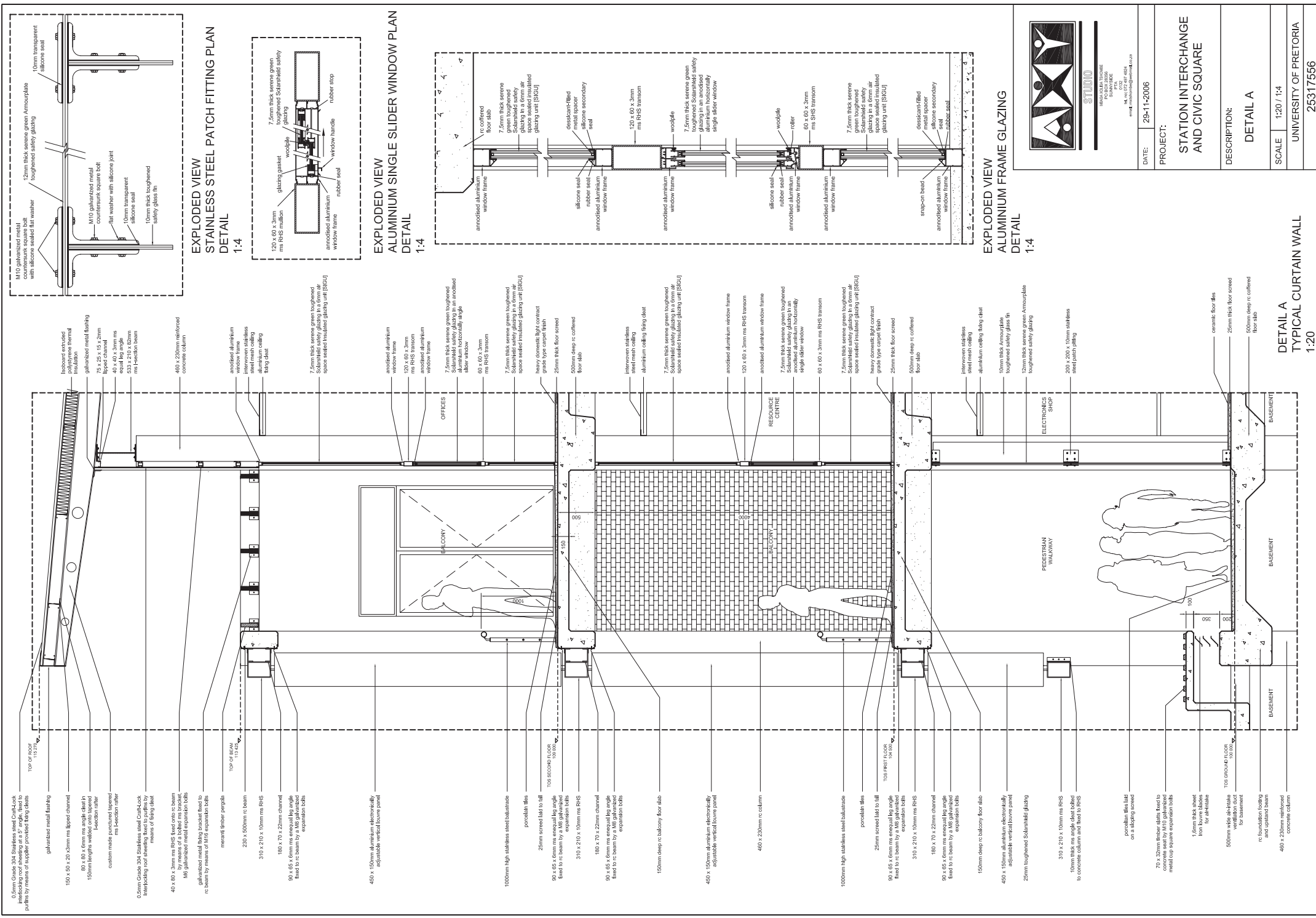

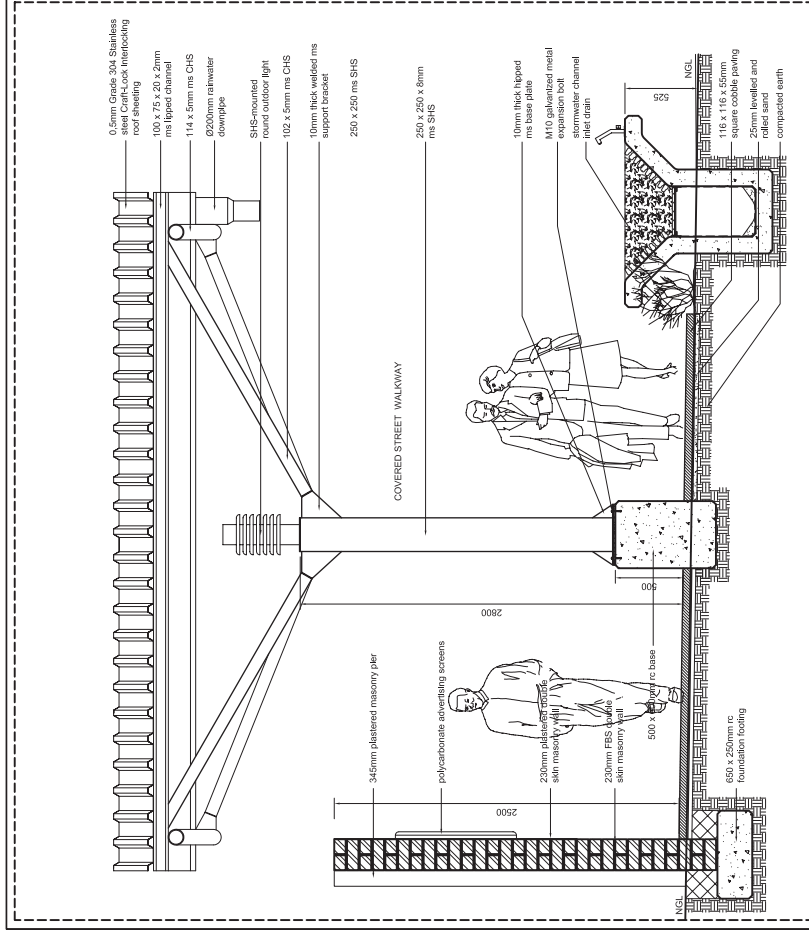

**DETAIL B  
STREET WALKWAY  
1:20**

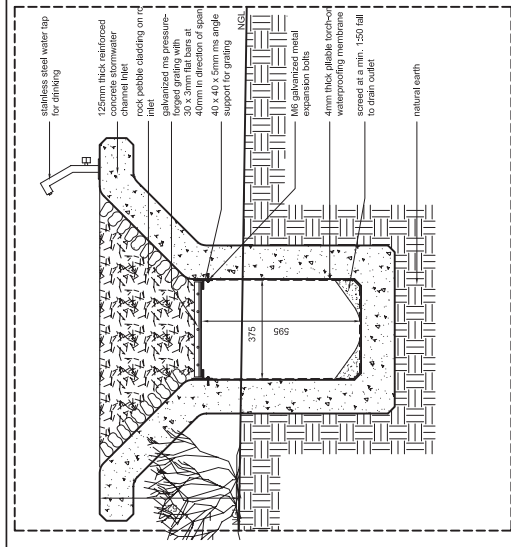

**EXPLODED VIEW  
STORMWATER CHANNEL INLET DETAIL  
1:5**

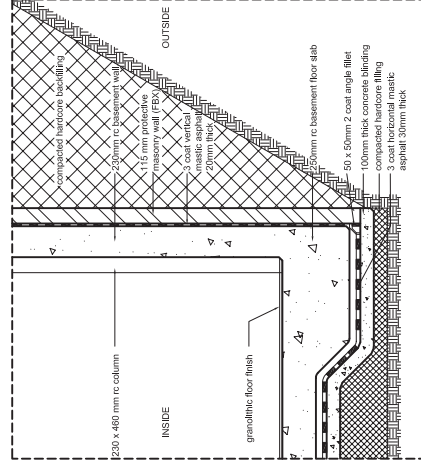

**DETAIL C  
BASEMENT DETAIL  
1:20**

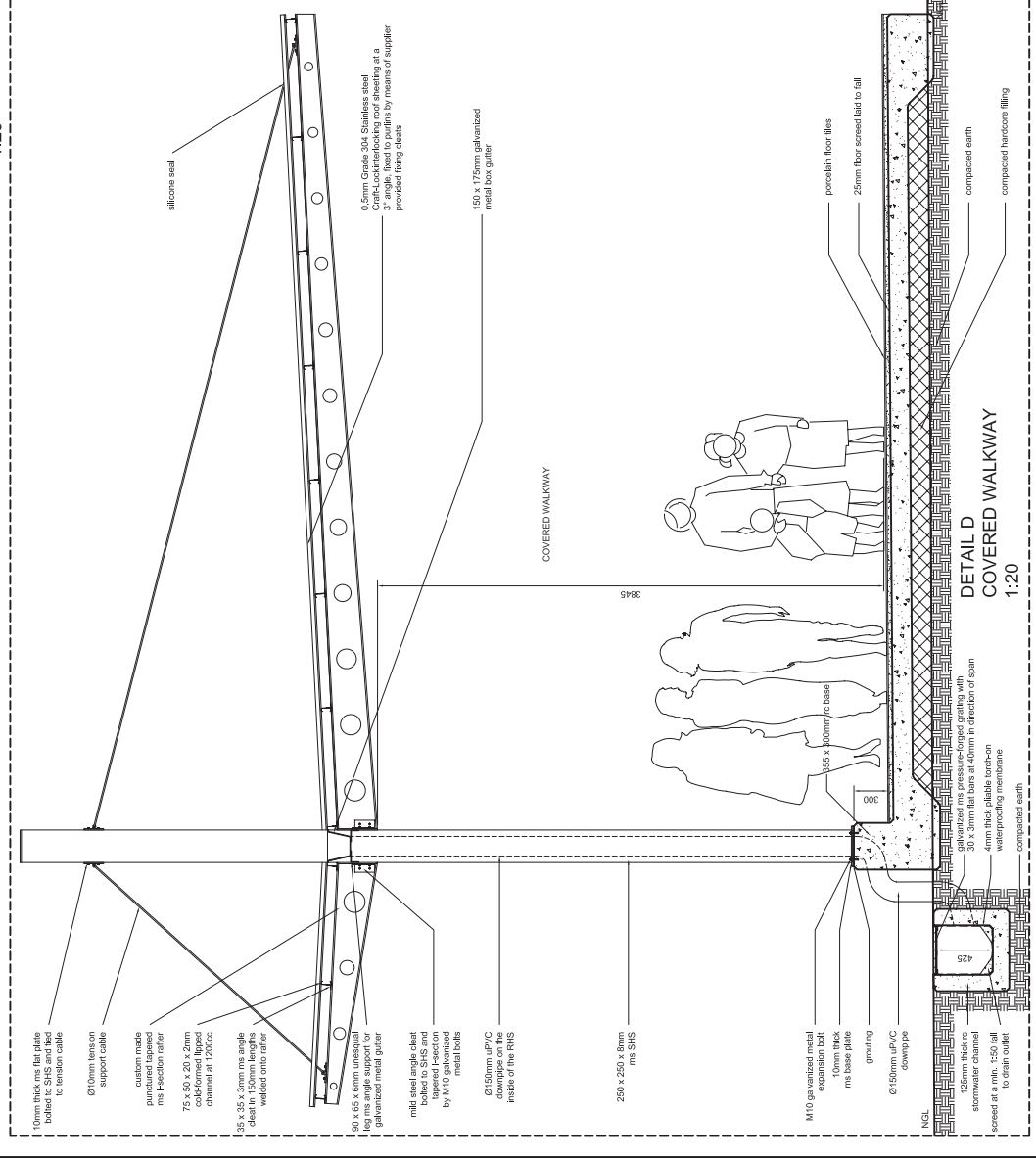

DATE:	29-11-2006
PROJECT:	STATION INTERCHANGE AND CIVIC SQUARE
DESCRIPTION:	DETAILS B, C, D
SCALE:	1:20 / 1:5
UNIVERSITY OF PRETORIA	
25317556	



# REFERENCES

## *REFERENCES*

AEDES EAST INTERNATIONAL FORUM FOR CONTEMPORARY ARCHITECTURE. (2005). FAST FORWARD JOHANNESBURG NEW ARCHITECTURE AND URBAN PLANNING IN SOUTH AFRICA. Aedes, Author and Architects.

ARCHITECT AND SPECIFICATOR JANUARY/FEBRUARY (2005). (pg 35-37) Energy efficiency, Ignore at your own Peril.

ARCHITECTURE SOUTH AFRICA. Journal of the South African Institute of Architects May/June (2006) (pg 40-45). Roots, Forms, and Relevance, Typological Patterns of indigenous settlements in Southern Africa by Gerald Steyn.

ARCHITECTURE SOUTH AFRICA. Journal of the South African Institute of Architects November/December (2004) (pg 33-36). Works of Significance. The South African Embassy, Berlin MMA Architects.

ARCHITECTURE SOUTH AFRICA. Journal of the South African Institute of Architects November/December (2004) (pg 86-88). Works of Significance. University of Pretoria Law Faculty Building by Kruger Roos Architects.

ASTRUP, R (2005). Pretoria Station Precinct and Community Development Centre. University of Pretoria electronic thesis document.

ATTOE, W; and LOGAN, D (1989). American Urban Architecture Catalysts in the design of Cities. Berkeley: University of California Press.

BACON, E.N. (1967). Design of Cities. London: Thames & Hudson Ltd.

BAKKER, K. (2004). Heritage report A for Salvokop Development Framework steering Committee. University of Pretoria: Pretoria.

CAPRA, F (1997). Web of Life: A new Scientific Understanding of Living Systems. New York: Anchor Books.

DAIKIN AIR-CONDITIONING SOUTH AFRICA INFORMATION MANUAL (2002).

DENYER, S(1978). African Traditional Architecture: An Historical and Geographical Perspective. London: Heinemann publishers.

DEWAR, D and UYTENBOGAARDT, R.S. (1991). South African Cities: A Manifesto for Change. University of Cape Town: Cape Town Urban Problems Research Unit.

ELLEH, N (1997). African Architecture. Evolution and Tradition. New York: Mcgraw-Hill.

FISHER, R; LE ROUX, S; AND MARE, E (1998). Architecture of the Transvaal. Pretoria: University of South Africa.

FREEDOM PARK TRUST BROCHURE (2005). Garden of Remembrance.

FREEDOM PARK ARCHITECTS IN ASSOCIATION (2003). Final Draft Urban Design and Development Framework, prepared for the Freedom Park Trust.

FRAMPTON, K (1980). Modern Architecture, A Critical History. London: Thames & Hudson Ltd.

GIBBERD, J (2003). Integrating Sustainable Development into Briefing and Design processes of Buildings in Developing Countries: An Assessment Tool. University of Pretoria thesis document.

GOOSEN, D.P. (2001). RST302-X UNISA Study Guide, Religion and Art: Aesthetic Religious Transcendence in the Modern and Postmodern Art and Architecture. Pretoria: University of South Africa.

GREED, C. and ROBERTS, M. (1998). Introducing Urban Space. Singapore: Longman Singapore Publishers [Pty] Ltd.

HOITING, H and BOER, F (2000). Sun and Architecture Examples and Guidelines for Architects. Utrecht: Novem Publications.

HOLM, D (1996). Manual for Energy Conscious Design. Pretoria: Department of Minerals and Energy.

<http://www.blueiq.org.za> Cited on 8 April 2006.

<http://www.federationsquare.com> Cited on 26 September 2006.

<http://www.freedompark.co.za> Cited on 20 August 2006.

<http://www.gautrain.co.za> Cited on 5 April 2006.

<http://www.google.com> Cited on 5 April 2006.

<http://www.info.gov.za> Cited on 5 April 2006.

<http://www.intersite.co.za> Cited on 8 April 2006.

<http://www.vitruvio.ch> Cited on 26 September 2006.

KRIER, R. (1979). Urban Space (Stadrum). London: Academy Editions London.

PERMANYER, L (1991). Barcelona Open-Air Sculpture Gallery. New York: Rizzoli International Publications, Inc.

RAMOSE, M.B. (1999). African Philosophy through Ubuntu. Harare: Mond Books.



## University of Pretoria etd, Tshombe MX (2007)

ROCCON, E.B. (2005). Gautrans Sub-Urban Train Station. University of Pretoria electronic thesis document.

SITE, ARCHITECTURE AS ART (1980). New York: St. Martins Press, Inc.

STATISTICS SOUTH AFRICA CENSUS 2001, Census in Brief Document, Second Edition.

STEELE, J (1997). Sustainable Architecture. New York: Mcgraw-Hill.

THE DIGEST OF SOUTH AFRICAN ARCHITECTURE (2001/2002). Volume 6. (pg 160-162) Global Warming: What's Architecture got to do with it by Llewellyn van Wyk.

THE PHAIDON ATLAS OF CONTEMPORARY WORLD ARCHITECTURE (2004). London: Phaidon World Press Limited.

TRANCIK, R. (1986). Finding Lost Space. New York: Van Nostrand Reinhold Company.

TSHWANE INNER CITY DEVELOPMENT STRATEGY (2005).

TUAN, Y. (1977). Space and Place. Minnesota: North Carolina Publishing Company.

UNIVERSITY OF PRETORIA (2000). Paul Kruger Street Spine. Urban Design Framework for the Improvement of Environmental conditions on Paul Kruger Street, prepared for the City of Tshwane Metropolitan Council.

WASSERFALL, J. (1989). Early Mine and Railway Housing in South Africa. DPhil thesis. Cambridge: University of Cambridge.