

technical study

- 01_technical design
- 02_structure
- 03_materials
- 04_structural calculations
- 05_construction process
- 06_building codes
- 07_project specifications

TECHNICAL STUDY INTRODUCTION

This section serves to highlight the numerous technical considerations and decisions taken towards the practical realization of the project. Success of any architectural structure is measured in part through its fabrication and construction processes which when successfully integrated with design can lead to both a feasible and provoking form. This investigation will thus impart to the reader, the processes of synthesis between the theoretical design objectives and the technical manner of their solution.

TECHNICAL DESIGN

There is sufficient basis in the authors experience to state that technical resolutions of designed spaces may at times, begin to either remove focus from the spatial design of the structure or, of greater concern, begin to detract from the initial expressions of the design.

It thus becomes of great importance for the author that objectives be stated and met, not only at a design level but at a technical level too, expressing similar thinking to that of the buildings design. To negate this step puts into jeopardy the clarity of expression and communication through the design.

Thus several objectives have been identified in the technical resolution of the design of this project, to be kept foremost in thought through the investigative process into solutions.

SPATIAL QUALITY PRIMARILY

Through the theoretical investigations expressed earlier in the book, focus was placed primarily on the quality of spaces in the facility during the design phase. In order that the design of the building be read in this manner, the viewer should not be asked to understand the physical construction and assembly of such spaces. The focus must be kept on the spatial experience of the user.

One may argue that technical articulation of space can however add to this spatial experience. This fact is true in the author's opinion and as such, remains the only exception to technical design.

Where the quality and experience of space is enhanced through technical articulation, only then is the solution permissible. Initial thoughts on possible examples of this could be tensile cable supports of an atrium stairwell, where the experience of rising through a space is enhanced through a lack of structural mass.

M A S S / V O L U M E I N T E R P L A Y

Point, line and plane generate through their interplay, volume. Space throughout the building becomes an interplay of these volumes, represented through the mass of the building.

The 'interlocking' nature of structural mass and spatial volume is used to enhance the readability of the design as an assemblage of spaces. Focus shifts to internal space by giving the appearance that structure has been pulled apart. The semi-congruent structural forms establish between them a sense of possible fit and inter-locking.

The use of relevant materials to suit this relationship will also enhance this aspect of the design by suitably positioning transparent and solid elements.

E X P R E S S I O N O F E L E M E N T S

Whilst visible construction detailing as mentioned before will only be appropriate in order to enhance spatial sensations, the expression of the building as a composition of smaller units each comprising smaller elements remains a firm design goal.

Enlightening visitors to the facility on the intricacies and complexities involved in the design and development of a built structure shall be communicated through the juxtapositioning of the various building elements. Walls, columns, piers, windows, partitions, doors and concrete slabs must remain identifiable as an individual element through the detailing yet also combine together to create a composition greater than the sum of its parts.

Throughout the building, various messages and devices will proclaim this relationship of built elements to each other and to the viewer.

This wall took 7 men,
2498 clay bricks,
12 bags of cement,
360 litres of water and
140 hours to build.

In a similar manner, all taps will be fitted with individual meters which will monitor the amount of water flowing through the taps. Electrical connections will also house individual meters displaying consumption of power from each point. In so doing, the user will begin to comprehend the building as an amalgamation of processes providing for the people contained within the structure.

Interestingly, these three technical objectives each concern themselves with a different scale in relation to the building structure, ranging from the large-scale massing to, medium-scale readability and the small-scale detailing of the technical structure.

S T R U C T U R E

The entire structure of the facility can be broken down into several core elements that require attention in isolation and then in relation to the other structural elements. The differentiations can arise out of material, practical or performance requirements and are to be analysed in the following sections.

R E I N F O R C E D C O N C R E T E F R A M E

Since the inception of reinforced concrete frame structures, this has become one of the most economical and easily constructed methods of building. With a focus on user spatial experience in the building, thought must in addition be bent towards the practicalities of erection and assemblage for such experience to even occur. The reinforced concrete frame is seen as the ideal solution to remove dependability of spatial layout on the structure to a degree. In the same breath, with the popularity of reinforced concrete frame construction, this project seeks to investigate in part an alternate approach to the building design using this structural system; to place space foremost and design with feasibility and functionality of secondary importance to user experience.

Design objective – To alter the manner in which structure dominates modern buildings and to free spatial experience from this, to allow space to permeate through the building and so give a tangible sense of space to the viewer.

Technical resolution – The reinforced concrete frame was decided upon due to its ability to allow spatial design freedom from alternatives such as load-bearing masonry or mass in-situ cast concrete.

S K Y L I G H T R O O F

Daylight is a highly important design consideration and its utilisation within a building in the South African climate is considered a must. With the high amounts of solar radiation South Africa receives, it is irresponsible of designers to not facilitate the use of daylight in their buildings. Whilst heat generation is a concern, the correct use of shading and reflective materials can ensure a minimal heat gain, combated by intelligent passive and mechanical ventilation systems.

Stemming from the theoretical ideas towards the designed structure, to encapsulate a sense of exploration through the structure and a process of unveiling and revealing along a path, the use of daylight is seen to connect this idea with the conceptual exploration of a canyon with its meandering route through rock, lit from above with daylight cascading down to the canyon floor.

Addressing practical concerns sees the inclusion of a central skylight as a method to improve office design quality through the use of natural light being able to permeate through both sides of office compartments, from the outside and the central atrium.

Design objective – To enhance the sense of exploration similar to that of exploring a natural environment and bring that experience into the building structure through the use of the skylight. To also improve the quality of working spaces, such as offices, in the building by allowing light to permeate from both sides. Ventilation vertically through the atriums and out through the skylights will also establish comfortable temperatures for the users of the building. Building occupants will as a result have an increased connection with the environment outside the building.

Technical resolution – In order to achieve continuity not only through design but construction too, the same construction solution as found in the arcade

portal frame structure will be used. This will allow a very fragmented and abstract form to be created to enhance the refraction and reflecting abilities of glass when in contact with light. Glass is required to be laminated safety glass which will be drilled and bolted to the frames with a UV reflective interlayer to reduce the problem of the greenhouse effect.

G L A S S A R C A D E

The existing arcade on the site was an abandoned, concrete roofed danger spot in the city block. All the shop units were available to let and no one utilised the arcade other than to gain access to the VWL Sentrum building. The redesign of the arcade and its incorporation in the CUBE facility has taken a reactionary approach in several aspects in opposition to the existing arcade.

Instead of solid enclosure which created a darker and potentially dangerous place, the materials of glass and steel only were selected to reduce structural member sizes and allow in the maximum volume of light. The single storey enclosure has been doubled in height and will act as a central movement route between both structures on site.

Design objective – Presently the VWL Sentrum tower block connects physically to the arcade as it wraps around the building like an apron. This approach was deemed unsuitable both functionally and design wise and was thus reversed in the new design. The establishment of the new glass arcade will separate the buildings, allowing each to stand independently and be observed thus with the arcade existing ‘as light a touch as possible’ between the two structures.

Technical resolution – The positioning of the arcade on the north and east sides of the VWL building ensured that it would be protected by the four storey height of CUBE, providing the necessary shade to create a

comfortable internal climate. A mono-pitch glass roof drains onto the CUBE facility's roof, protecting the internal arcade space. Steel portal frames constructed off site were designed to be positioned easily and quickly, attaching onto the concrete structure of the CUBE building to act as the frames for the glasswork of the arcade.

S T E E L T R U S S B R I D G E

Design objective - The bridging of the two halves of the building on either side of the courtyard serves several purposes. Firstly to provide a direct route between the office areas on the upper floors and eliminate the need to return to ground floor to access the other side of the building; an inefficient and time costly exercise in circulation. Secondly to provide partial protection to the courtyard and the users below. In addition to this shading is provided to the arcade space too allowing a shaded and cooler public movement route. The design of the building structure ensures that direct sunlight will only be allowed to penetrate for a small amount of time during the day.

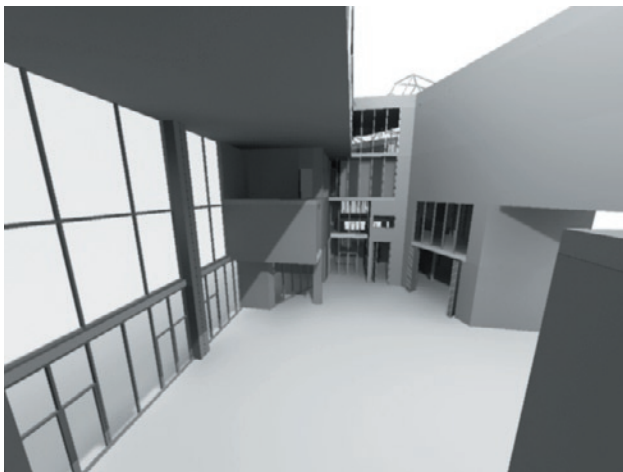

Fig.11_01.Shading of arcade

Technical resolution – The lack of vertical supports for approximately 18m resulted in the selection of a steel girder truss to bridge the distance between buildings. This provided an economical structure which could be assembled on site post fabrication and integrated into the existing structural layout of the concrete frame buildings with relative ease.

M A T E R I A L S

The smallest scale of technical design deals with the physical properties of the materials which will be used to achieve the proposed structure and all the considerations required at this level to achieve the design.

C O N C R E T E

- Shuttering considerations

The process of building within the narrow confines of the site does represent some technical problems with the assemblage of shuttering for the concrete super structure. Consideration has been given to the close proximity of the building to the surrounding structures and adequate space provided. The cantilevering slab edges have been provided with sufficient distance between column and edge to allow shuttering modules to be used.

- Mixture ratios for strength ratings

A design strength mixture of 30MPa has been used in the calculations of the building structure. A suitable mixture according to engineer's specifications and complying with cube and slump tests will be used.

- Fire resistance

Depending on the thickness of the concrete element the resistance to fire will vary. However with similar ratings as clay brick wall, concrete provides adequate support during a fire for the protection of evacuating people. According to SABS 0400, a minimum of 120 minutes is required for the safe evacuation of the



Fig.11_02. Concrete finish example

designated occupancy class of the building. This equates to a minimum of 50mm cover on structural steel members and plastered brick walls of 150mm in thickness.

- Max spans, cantilevers and thicknesses

The various methods of concrete construction were considered. Coffer slabs however were rejected due to the increased thickness of the slab and inability to run services below the slab. Flat slab construction was chosen with reinforced concrete beams along the outer edges to provide support to the cantilevering edges. A structural grid of 6m x 5m was chosen which allowed a 250mm-280mm slab thickness. The reduced thickness of the slab allowed the use of

suspended ceilings to hide service conduits without requiring significant floor to ceiling heights.

All slab edges are designed to cantilever to improve structural bending moments in the concrete. The increase in space between the structure and neighbouring buildings will create a far less difficult construction problem.

Maximum spans are set at 8m with the inclusion of reinforced edge beams to improve stability.

- Reinforcing required

Various thicknesses of mild steel bars are used in the reinforcing of concrete. Whilst the steel does need to be made into the reinforcing cages, the fabrication process can be done off-site. Rapid construction speed once the reinforced cages are delivered, can be achieved.

- Service life

Concrete is a remarkably robust, durable and strong material. If there are no faults made during the erection of the concrete structure, there is little which can negatively affect the structure other than earthquake damage, explosions, fires or flooding.

- Construction and expansion joints

The expansion of concrete is similar to that of brickwork which makes the two materials ideal to be used in conjunction. Expansion calculations predict that a 20mm construction joint will be required every 18m-25m for which the design catered. Expansion and day joints during the erection process would be located at column and slab junctions where the completion of a days work resulted in the differing curing times of different elements.

- Concrete finishes

A variety of finishes allows designers to achieve a large range of aesthetics looks from concrete. Hacking, sandblasting, brushing, grinding, painting and arbeton are all locally used finishes which range from a fine sand texture to a large particle abrasive look. The required concrete finish for the project will utilise brushing to achieve a fine, sandy, rock texture similar to that of sandstone cladding found

on neighbouring buildings. The use of sandblasting is restricted within the city and as such the brushing technique has been chosen.

- Adaptability of structure

Once built, the concrete structure will not be able to be altered without significant construction being required. However the adaptability of brick walls and partitions utilised within the concrete frame is not restricted at all other than by the service ducts. This does allow a large range of possible variations to be done during the buildings lifespan should it be necessary to alter the buildings spaces.

- Reasons for choice

Concrete remains one of the most economical construction materials. The process of reinforced concrete construction is also very fast which can reduce time spent on site by contractors and workers. It is a robust material with a variety of textured finishes which relate to the surrounding buildings and the extensive use of concrete throughout Pretoria. The texture especially relates to one of the design ideas of generating a rough, rock-like texture to enhance the sense of exploration through a built structure.

- Sourced from location

Multiple locations around the city provide concrete ingredients and readymix concrete which can be transported to site with relative ease.

- Location in building

Reinforced concrete is used as the main structural element of the CUBE building. Reinforced concrete columns and slabs provide the necessary vertical and horizontal load paths to support the designed spaces with minimal support sizes.

- Alternatives

Loadbearing brickwork was considered as the structural material but was rejected through the increase in support sizes. Space on site was greatly restricted and minimal supports were required.

Steel frame construction was considered as well due to the minimal area required for the vertical supports. However steel construction remains costly

and requires high amounts of energy to be produced. Both these alternatives were rejected in favour of the economical and common concrete construction system.

G L A S S

- Type of glass

Any use of structural glazing requires that certain pane thicknesses are used in specific situations. For the construction of the arcade, all the glass will be required to be laminated safety glass and comply with the necessary class ratings for safety. Comprising two layers of clear float glass with a PVB interlayer of 0.76mm will allow the glass work in the arcade to comply with class 2 safety ratings for high impact and burglar proof glass. The incorporation of the interlayer will hold glass fragments together safely should the glass pane break.

- Pane sizes available

Laminated glass is produced from multiple panes of clear float glass which is manufactured in sizes of 2400mm x 3200mm. The various thicknesses can vary from 2, 3, 4, 6 to 10mm. For the construction of the arcade glass floor 2 x 10mm thick laminated glass will be used with 2 x 6mm thicknesses used for the walls and roof.

- Fire resistance

Ordinary clear float glass does not react well under the influence of fire with most of the glass breaking due to heat stress or pressure variations. Laminated safety glass however has the benefit of increased numbers of glass panes and the PVB interlayer which binds the layers together, providing additional strength to the glass pane.

- Framing types

Extruded aluminium frames are easily available but do require large amounts of energy during manufacture. Steel window frames are also readily available in the Pretoria area with the added benefit of being able to be recycled. Both are used in the building with

aluminium frames used in visible public areas and in folding doors due to their appearance.

- Sourced from location/manufacturer

With the only float glass plant in South Africa located in Springs, Gauteng, the glass will be purchased either directly or through a secondary manufacturer in the case of either tinted or laminated glass. The availability of glass in the immediate area thus does not require large expenditure on travelling costs.

- Location in building

The predominant use of glass is found in the construction of the arcade. Elsewhere in the building glass is mainly used in windows, stacking and folding doors and display areas.

- Alternatives

Annealed or toughened glass construction was considered in place of the laminated safety glass but several aspects resulted in the decision to remain with the safety glass.

The high cost of toughened glass due to the additional processes involved in the manufacture of the glass was an initial disadvantage. The process of producing toughened glass also results in the panes not being allowed to be drilled or cut in any way as the stress forces between the layers of glass would cause the pane to break. Since construction of the arcade required the panes to be drilled to be fixed to the framing system, the ability to use toughened glass was voided.

Steel sheeting panels were also considered however the inability to allow light through was a major design drawback. However a similar system of using perforated and patterned steel sheets clipped onto the glass panes was chosen to be used in the design to create unique light shadows and spatial sensations.

S T E E L

- Location and usage in building

Mild steel bars are the reinforcing material used in conjunction with concrete in the structure of the building. The steel provides much greater tensile strength for spanning distances in contrast with concretes significant compressive strength for vertical load transfers.

The public arcade uses purely steel construction to support the glass work in order to reduce member sizes and create a design aesthetic based on transparency and light.

- Sizes available

Steel profiles vary in their dimensions according to manner of manufacture and profile shape. Hot-rolled H-profile steel members are used as the main vertical column supports for the arcade structure. I-profile beams are used to span horizontally between supports with angle profiles used to fix elements together and provide surfaces on which to secure and weld other members.

- Sourced from location

Several steel producing plants exist around South Africa with many located in Gauteng in the surrounding cities and towns of Pretoria. Whilst steel is high in embodied energy and heavy to transport, the benefit of being able to recycle steel components qualifies steel as a suitable construction material.

- Methods of fixing

Bolting remains the main method of fixing steel elements together in this project. The ability to disassemble the structure will allow future construction or repairs to be undertaken far more easily than if the structure was welded. High-friction bolts and washers have been used on structural steel joints and connections with the reinforced concrete super structure.

- Alternatives

Reinforced concrete of the main building was considered as the material for the arcade. However

whilst the member sizes of concrete and steel columns may have been only of minor variation, it was the design aesthetic of steel as a clean and precise material that was preferred in conjunction with the glass work of the arcade.

B R I C K W O R K

- Types of bricks

Three main types of clay brick are produced locally. Non Face Plaster bricks or 'stock' bricks are used in the construction of walls which will be plastered or rendered at a later stage. These are the chosen clay bricks for use in the project where internal, non-loadbearing wall will be finished to appear similar to concrete. Face Brick Aesthetic and the other classes of face bricks as well as the Non Face Extra category are the other two types of clay bricks produced in South Africa.

- Fire resistance

SABS 0400 gives a 120 minute safety rating to a brick wall of 150mm when plastered. The design of the internal walls of the building are single-brick 240mm thick walls which will comply adequately with the required resistance to fire.

- Finishing

All brick surfaces are to be plastered with small to medium sized aggregate and brushed to produce a sandy, rough finish similar to brushed concrete. The design seeks to create a semi-natural, rock-like feel to the structure which will enhance a sense of exploration through the building.

- Mortar

Mixtures according to manufacturers specifications to be used as the brickwork mortar.

- Jointing

Due to the plastering and rendering processes to be performed on the wall post construction, no specific jointing is required.

- Location in building

All walls as indicated on plans will be constructed

from clay bricks and plastered.

F I N I S H E S

- Tiling

Ceramic tiling will be used in all bathrooms. Manufacturers directions for tiling cement and backing fixative must be followed to ensure the tiles do not displace under the influence of water and condensation.

- Power screed

A power trowel will be used to finish off a concrete screed over the concrete slab floors. The smooth finish of the concrete floor will provide a smooth and level surface on which to walk and be aesthetically similar to the finish of the walls.

- Plaster

A plaster mix with a small percentage of medium grain aggregate to be used on all clay brick walls. A light sand colour similar to that of sandstone to be used. After several days of drying time the plaster will be brushed to provide a semi-smooth, sandy texture with an irregular spread of medium particles.

- Paintwork

The steel construction of the arcade must be painted once all welds and joints have been completed, prior to the installation of the glass work. Suitable base coats and matt gun-metal grey coloured overcoat will be used to provide protection to the steel. An intumescent paint layer will also be applied to provide some resistance to fire and ensure sufficient time for the evacuation of the arcade space.

S T R U C T U R A L C A L C U L A T I O N S

The following pages document some of the initial calculations of structural member sizes and loading that could be expected from the designed building.

CONCRETE EXPANSION: $12 \times 10^{-6} \times 40 \times 28000 \text{ mm}$ University of Pretoria etd - Sackett, C (2007)

= 13.44 mm over 28 meters
 ∴ 6.7 in ONE DIRECTION
 ∴ 20mm JOINT SUFFICIENT

CANTILEVER $\frac{L}{8} = d$

$\frac{1300}{8} = 162.5$



TOTAL CRUSHING FORCE

∴ $7.5 \times 6 = 45 \text{ m}^2$

$h = \frac{L}{24} = \frac{8000}{24}$ USING 280 A3 PRELIM.
 = 333 mm

∴ $V = 45 \text{ m}^2 \times 0.28 \text{ m}$
 = $12.6 \text{ m}^3 \times 2.400 \text{ kg/m}^3$

1xSAB = 30240 kg (30.24 kN) **302.4 kN**

5xSAB = 151.2 kN (151200 kg) **1512 kN** **DL**

LL OFFICE BUILDING - 2.5 kN/m²

$LL_T = 1.6 \times 2.5 \text{ kN PER FLOOR}$
 = 4 kN/m²

$LL_T = 4 \text{ kN} \times 45 \text{ m}^2 \times 5$

$LL_T = 900 \text{ kN}$

$P_f = 1.2(DL) + 1.6(LL)$
 = $1.2(1512) + 900$
 = $1814 + 900 = 2714.4 \text{ kN}$

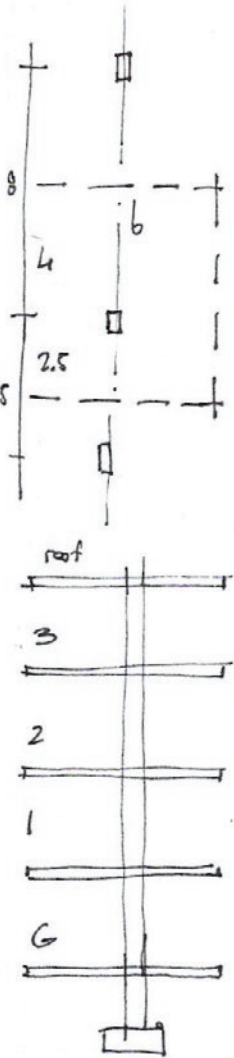

$C_r = 0.35 \times 30 \text{ MPa} \times A_c$

$\frac{\text{FORCE}}{\text{AREA}} = \text{STRESS}$

$A_c = \frac{C_r}{0.35 \times 30}$
 (mm²)
 = $\frac{151200 \text{ N}}{0.35 \times 30 (10.5)}$
 = 144000 (SAFE CASE)

$C_r = (0.35 \times f_{cu} \times A_g) + (0.6 \times f_y \times 0.02 A_g)$
 = $(0.35 \times 30 \times 0.98 A_g) + (0.6 \times 300 \times 0.02 A_g)$
 = $10.29 A_g + 3.6 A_g$

$1512 = 13.89 A_g$
 $\times 10^3 \text{ N} = 111258.3 \text{ mm}^2$

$450 \times 250 = 112500$
 ∴ WILL SUFFICE



$450 \times 250 = 112500 \text{ mm}^2$
 ∴ NOT ENOUGH

• $150900 = 500 \times 300$

$\frac{CA}{LTA} = 0.0025\% \times 100$
 = 0.25% OF FLOOR AREA

STEEL AREA IN COLUMN

$$A_{sc} = 0.02 \times 111258.5$$

$$= 2225.166$$

$$6 \text{ BARS} \times 370 = \pi r^2$$

$$r = \sqrt{\frac{370}{\pi}}$$

$$r = \phi 11 \text{ BARS}$$

$$d = \phi 22$$

$$= 0.35 \times f_{yk} \times A_s + 0.6 \times f_y \times A_c$$

$$= (0.35 \times 30 \times 0.78 A_g) + (0.6 \times 300 \times 0.02 A_g)$$

$$= 10.29 A_g + 3.6 A_g$$

$$2714.4 = 13.89 A_g$$

$$\times 10^3 = 195421 \text{ mm}^2$$

$$\approx 442 \times 442 \text{ mm}^2$$

$\therefore 450 \times 350$ WILL NOT SUFFICE

+ [500 x 390]

+ [550 x 350]

+ [600 x 385]

$$A_{sc} = 0.02 \times 175421$$

$$= 3508.42$$

$\therefore 10$ BARS OF 390.8 mm²

$\therefore 12$ " OF 325.7

$\therefore 14$ " OF 279

ALPHA = πr^2

$$\therefore r = \sqrt{\frac{A}{\pi}}$$

(10) $r = \sqrt{124.4}$

$r = 11.1$

$\therefore \phi 22 \times 10$ BARS

$\therefore 16 \times \phi 16$

(12) $r = \sqrt{103.7}$

$= 10.1$

$\therefore \phi 20 \times 12$ BARS

(14) $r = \sqrt{88.8}$

$= 9.4$

$\therefore \phi 18 \times 14$ BARS

$$\frac{CA}{LTA} = \frac{0.2}{45} = 0.0044$$

$$= 0.44\%$$

GLASS WEIGHT

$\approx 2400 \text{ kg/m}^3$

$5.5 \text{ m} \times 0.01 = 0.055 \text{ m}^2$

$0.05 \times 2400 = 132 \text{ kg/m}$

$f_g = 1.2 \times 132$

$= 158.2 \text{ kg/m}$

$\approx 1.6 \text{ kN/m}$

$15.5 \times 0.006 = 0.093$

$0.093 \times 2400 = 223.2$

$1.2 \times 223.2 = 267.8$

$\approx 2.8 \text{ kN/m}$

$5 \times 0.01 = 0.05 \text{ m}^2$

$0.05 \times 2400 = 120 \text{ kg/m}^2$

$1.2 \times 132 = 158.2$

$\approx 1.6 \text{ kN/m}$

$\approx 11.5 \text{ m} \times 0.01 = 0.115$

$0.115 \times 2400 = 276$

$1.2 \times 276 = 331$

$\approx 3.3 \text{ kN/m}$

(VARY TO PORTAL SIZE)

TOTAL GLASS WEIGHT W/ PORTAL

$1.6 + 2.8 + 2.9 + 1.6 + 3.3$

$= 12.2 \text{ kN/m}$

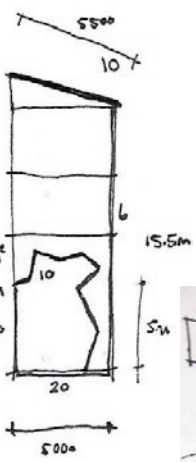

STEEL PORTAL WEIGHT

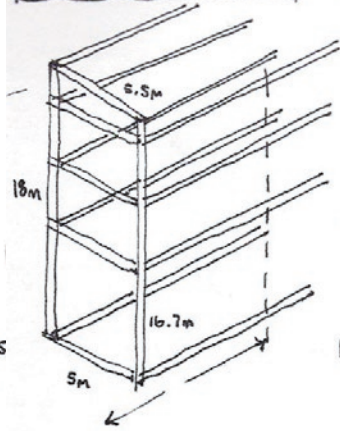

$\approx 7000 \text{ kg/m}^3$

Area = $2(6.250 \times 0.015) + (250 \times 15)$

$= 0.01125 \text{ m}^2$

$\therefore 0.01125 \times 7000 \times 1.2$

$= 94.5 \text{ kg/m}$

$= 0.94 \text{ kN/m}$



$\therefore \text{PORTAL}_w = (18 \times 0.95) + (16.7 \times 0.95) + (55 \times 0.95)$

+ $4(5 \times 0.95)$

$= 57.19 \text{ kN}$

$\text{Box}_w = 10(6 \text{ m} \times 0.95)$

$= 57 \text{ kN}$

\therefore TOTAL BOX SEGMENT WEIGHT

$= 57.19 + 57$

$= 114.19 \text{ kN}$

STEEL CALCULATIONS

STEEL LOAD

GLASS LOAD

THICKNESS = 20mm

DENSITY = 2,400 kg/m³

DENSITY = 7000 kg/m³

STEEL LENGTHS: 18 + 20 + 5(5) + 5.5

LENGTH = 5.5 + 26 (OVERLAP/RESSURE)

STEEL WIDTHS: 10 (6)

= 31.5m x 6m = 189m²

∴ 189m² x 0.02 = 3.78m³

W = 3.78 x 2400

= 9072 kg (91 kN)

DL_f = 1.2 (91)

= 109.2 kN

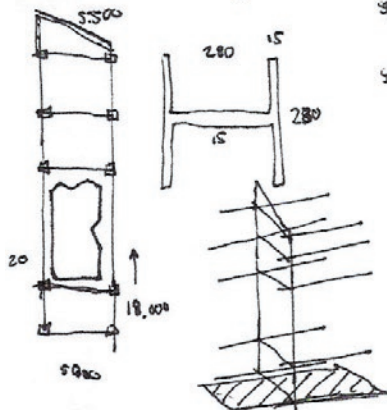

• 305 x 305 x 137 (13.8)

$$C_r = \phi \times (A)^2 \times f_{eff} \geq C_f$$

$$320.2 \text{ kN} = 0.9 \times A \times 46 \text{ mm}$$

$$\frac{320200 \text{ N}}{0.9 \times 46} = A$$

$$A = 7734$$

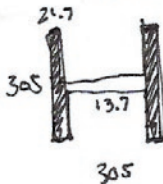

$$A = 2(305 \times 21.7) + (2616 \times 13.7)$$

$$= 13237 + 3583.9$$

$$= 16820.9$$

N = 10 x M

∴ 128.5m x 137kg = 17604 kg per bm
 FACTOR FOR SAFETY OF LIVE + DEAD LOADS
 RUBIC AREA = 5 kN/m²
 ∴ LL_f = 1.6 (5 kN x 5 x 6m)
 = 240 kN OVER 6m AREA
 DL = 17604 kg (176 kN) 1.2
 = 211 kN WITH INCREASE WATER WITH GLASS WEIGHT

$$\therefore = 320.2 \text{ kN} / 2$$

∴ 160.1 kN per COLUMN

$$SR = \frac{A}{S} = \frac{3600}{138}$$

$$= \frac{f}{r} = \frac{3600}{18.2}$$

$$= \frac{3600}{78.2} \text{ or } \frac{3600}{138}$$

∴ 46 OR 26.2

PORTAL BOX

- 26m PROFILE LENGTH x 6 PORTALS
- 18 LENGTHS OF 6m

$$\text{PORTAL BOX TOTAL} = 1153.15 + 798 =$$

$$= 1951.15 \text{ kg}$$

$$= 19.51 \text{ kN}$$

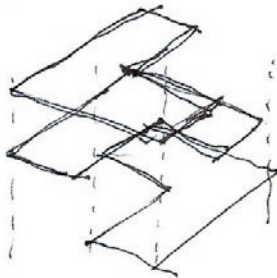
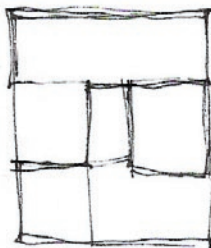
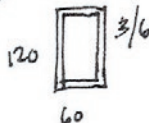
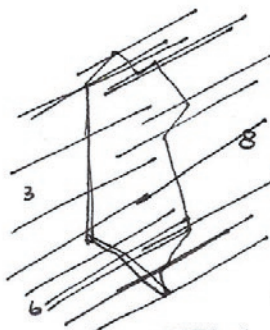



T E C H N I C A L P R E C E D E N T S

S P A N D A U T R A I N S T A T I O N B E R L I N

Completed recently, the new Spandau Train Station in Berlin has become the largest train station in Europe. Of particular significance is the massive glass and steel tunnel construction which provides protection to the trains and passengers.

A series of large, hollow-profile steel arches span the space and give support to smaller intermediate arches. The glass work is integrated into this supporting structure along the outer edge.

The resulting structure sees the structural arch frames put into compression with diagonal tension bracing cables connected along the inside of the structure. This ensures the supports remain in compression and provides lateral stability.

Fig.11_03.Support detail view (above), Lyall, S, 2002

Fig.11_04.Vault construction (below left), Lyall, S, 2002

Fig.11_05.Vault elevation (below right), Lyall, S, 2002

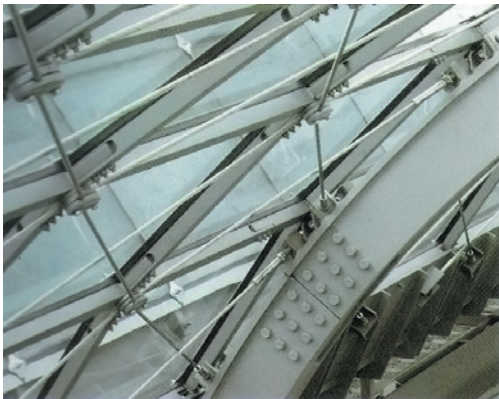

O R A N G E R Y P R A G U E C A S T L E

The construction of this project provides an alternative to the traditional glassed vault. In this instance, the supporting framework and the glass have been separated to form two different skins; the outer structure supporting the inner glass work.

In contrast to the Spandau Station's construction, the Orangery utilises circular, compressive, diagonal members to support the load with very little vertical structure required. The elimination of these typically large vertical support members allows the transparent nature of the glass to be enhanced.

The glass panes are laminated safety glass, bolted to stainless steel joints which are ingeniously integrated into the support structure. Such a construction allows the internal space to be entirely surrounded by glass work creating a smooth and homogenous surface.



Fig.11_06.Outside view (above right), Lyall, S, 2002

Fig.11_07.Inside view (below right), Lyall, S, 2002

Fig.11_08.Details (below), Lyall, S, 2002



B U I L D I N G C O D E S A N D S T A N D A R D S

R E I N F O R C E D C O N C R E T E

- SANS 1083 – Aggregates for Concrete
- SANS 0109 – Concrete Floors (part 1 and 2)
- SANS 0161 – Design of Foundations for Buildings
- SANS 0100 – Structural Use of Concrete
- SANS ENV 197-1 – Cement
- SANS 920 – Steel Bars for Concrete Reinforcement

C L A Y B R I C K W O R K

- SANS 227 – Clay Bricks Masonry Units
- SANS ENV 413-1 – Masonry Cement
- SANS 28 – Metal Ties for Cavity Walls

G L A S S W O R K

- SANS 1263 – Safety Glazing Materials
- SANS 1305 – Sealing Compounds, Silicone based
- SANS 0137 – Installation of Glazing Materials
- SANS 50572 – Work on Glass for Glazing

S T E E L W O R K

- SANS 1431 – Weldable Structural Steel
- SANS 044 – Welding
- SANS 064 – Preparation of Steel Surfaces for Coating
- SANS 14713 – Structural Steel Component Design
- SANS - Fire Protection of Steelwork
- SANS 1319 – Paint Primer
- SANS 684 – Structural Steel Paint
- SANS 1700 – Fasteners
- SANS 1282 – High Strength Bolts, Nuts, Washers

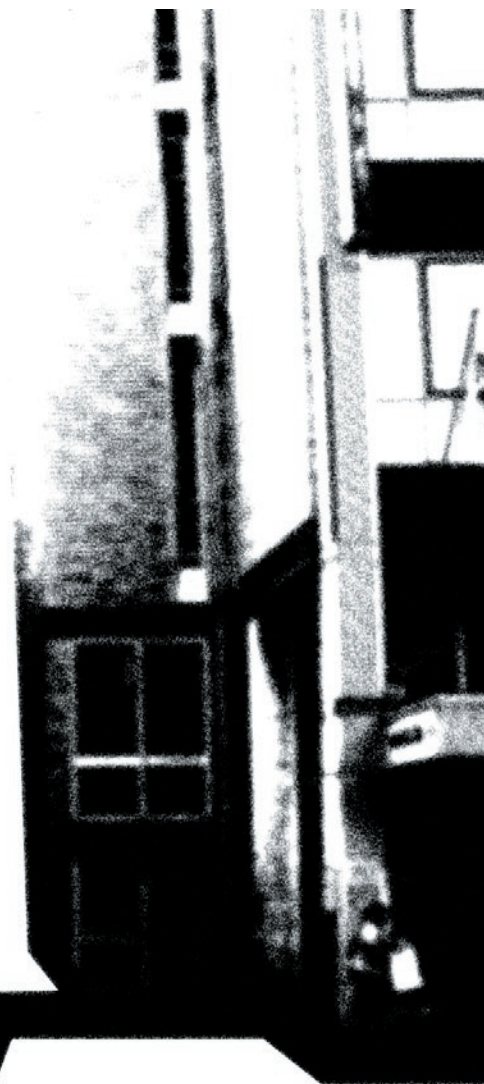

Fig.11_09.Pretoria News building

P R O J E C T S P E C I F I C A T I O N S

R E I N F O R C E D C O N C R E T E

Storage

Keep all bagged cement stored under cover and dry until ready for use.

Type, composition and strength of cement to be indicated on bags with the SABS mark of compliance to manufacture.

Always use oldest cement first and in proceeding chronological order.

Do not use cement with lumps that cannot be crumbled by hand and cement which may have been contaminated with foreign material due to bag being opened or damaged.

Preparation of Shuttering

Ensure access to sufficient quantity of shuttering prior to project execution.

Timeous erection of shuttering and supports to be followed in accordance to the preparation of the concrete mixture.

Shuttering to be cleaned and prepared with suitable non-adhesive coating prior to casting.

Ensure no foreign, organic or chemical matter is left inside shuttering prior to casting.

Steel reinforcing cage positions to be checked and monitored by engineer during construction.

Correct shuttering material to be used in accordance with architects specified finishes for the surfaces as indicated on drawings. All concrete surfaces will be finished as defined below or as otherwise specified.

Shuttering to remain in position until approval given by the engineer.

Supports to remain in place while slabs cure until full concrete (28 day) strength is achieved.

Notice

Give timely notice in advance to the architect or principal agent before commencing with casting of concrete.

Reinforcement

Steel reinforcing bars sizes and tensile strength to engineer's specifications.

Ensure reinforcing cages are checked by engineer or contractor for integrity upon delivery to site or post-assembly if constructed on site.

Reinforcing cage placement within shuttering to be monitored and checked by engineer or contractor prior to commencing with casting.

Clean steel reinforcing cages of foreign and organic matter and brush with steel brush prior to casting.

Concrete Mix

Mix cement, sand and stone by volume or mass to produce the specified compressive strength at 28 days according to engineers specifications.

Mixing of concrete to be done by machine.

Proportions to be calculated prior to mixing according to either the cement manufacturer's instructions or the engineer's certified design mix.

Ensure adequate stock of all materials is stored on site prior to commencement of mixing.

Examine aggregates for continuity in colour and appearance and do not use any aggregate material which falls outside acceptable limits.

Ensure sand aggregate complies with SANS 1083 and acceptable particle size distribution is achieved.

Ensure stone aggregate complies with SANS 1083 and only particle sizes as specified by the engineer are used.

Have sand filtered prior to mixing to remove organic and foreign material.

Water

Water to be used in mix must be potable, clean and free from any amount of acids, alkalis, organic matter

or any chemical substance which could impair the strength or durability of the concrete.

Ensure water tests are conducted if there is any doubt about the source.

Curing

Cast concrete to be cured for seven days; longer if ambient temperatures fall below 10°C.

Ensure concrete surface remains damp by spraying with water and protect all surfaces with polyethylene cover sheeting.

Testing

Cast concrete test cubes of size and quantity at intervals as specified in accordance with SANS test methods 861-2 and 861-3.

Have all test cubes tested for compressive strength at an approved laboratory according to SANS test method 863.

Finishing of surfaces

Surfaces of concrete to remain off shutter with any honey combing or voids made good according to approved methods.

Surface discolourations be allowed to remain.

Concrete to be grinded to smooth surface three days after casting.

A R C A D E G L A S S W O R K

Material

Arcade glasswork to consist entirely of clear laminated float glass with 0.76mm polyvinyl butyral interlayer to comply with SABS 1263 part 2 for burglar-resistant strength (High Penetration Resistance).

Sandblasted laminated glass floor panes to be 20mm in thickness and factory cut to specified sizes prior to transport to site.

Clear laminated float glass panes of 12mm thickness

to be used for wall and roof glazing of the arcade passageway.

Markings specifying glass strength class to be visible after installation and situated at bottom left corner of the pane.

Preparation

Glass panes must be stored in a secure area on site and held stable in a vertical position. Laminated glass panes to be examined prior to installation for surface imperfections, delamination, cracking and any other defects or damage. Glass panes not passing inspection will not be approved for installation and must be replaced.

Do not cut any glass panes on site with a thickness greater than 4mm.

Ensure frames are clean, dry and true to shop drawings prior to installation of panes.

Fixing

Laminated safety glass must be cut and drilled upon completion of manufacture to the specified dimensions as laid out in the glass specialist's report once pane dimensions have been measured and confirmed to be suitably accurate in relation to the supporting frame construction on site.

High strength bolt as per engineers specifications and complying with SABS 1282.

Neoprene washers to be used on both sides of glass pane where in contact with bolt head and nut.

Jointing and sealants

Glass panes joints to remain open unless where specified on drawings.

Where required a silicone rubber sealant complying with SABS 1305 will be used. Joint sizes to be 12 - 20mm maximum in width.

A suitable backing material that does not adhere to the structural frame such as cellular polyurethane foam or fibrous soft board must be used.

Sealant must be fungus proof.

Protection and Cleaning

Protect against harmful splashes and weld spatter.

Damaged glass panes must not be installed.

Clean as soon as practical after installation with mild soap and water mixture.

Ensure cleaning equipment and materials are not harmful to glazing surface or sealant compounds.

Completion

Obtain a warranty by the manufacturer of the laminated glass against delamination for a minimum period of five years.

Obtain written proof that all stages of fabrication and installation have been completed in accordance with the relevant level of quality as specified in SABS ISO 9000

Provide written proof that the sealants specified for use in the glazing installation are compatible with the framing material, any tape used and the glass type specified.