

# adaptive reuse of the agrivaal building

---

by  
Neda Samimi

# adaptive reuse of the agrivaal building

---



SUBMITTED IN PARTIAL FULFILMENT OF THE  
REQUIREMENTS FOR THE DEGREE  
MASTER OF ARCHITECTURE (PROFESSIONAL)  
DEPARTMENT OF ARCHITECTURE  
FACULTY OF ENGINEERING, BUILT ENVIRON-  
MENT AND INFORMATION TECHNOLOGY  
UNIVERSITY OF PRETORIA

Study leader: Karel Bakker (Prof.)  
Course coordinator: Jacques Laubscher (Dr)

PRETORIA  
2011

Full dissertation title: **Adaptive Reuse of the Agrivaal Building**

Submitted by: Neda Samimi (Miss)

Student number: 24115704

Study leader: Karel Bakker (Prof. )

Course coordinator: Jacques Laubscher (Dr)

Degree: Master of Architecture (Professional)

Department: Department of Architecture

Faculty: Faculty of Engineering, Built Environment and Information Technology

University: University of Pretoria

## project summary

Programme: New Headquarters for the Delegation of the European Commission in South Africa

Site description: Adaptive reuse of an existing dilapidated building

Client: The Delegation of the European Commission for South Africa, The European Union.

Users: Staff of the European Commission, Government and non-governmental organisations, general public

Site Location: Erf 1087, Arcadia, Pretoria

Address: c/o Hamilton Street and Edmond Street, Arcadia, Pretoria, South Africa

GPS Coordinates: 25°44'26.00" S, 28°12'18,32" E

Architectural Theoretical Premise: The investigation of the principles of environmental sustainability and heritage

Architectural Approach: The adaptive reuse of an existing building using principles of cultural significance and environmental sustainability

Research filed: Environmental potential

In accordance with Regulation 4(e) of the General Regulations (G.57) for dissertations and theses, I declare that this thesis, which I hereby submit for the degree Master of Architecture (Professional) at the University of Pretoria, is my own work and has not previously been submitted by me for a degree at this or any other tertiary institution.

I further state that no part of my thesis has already been, or is currently being, submitted for any such degree, diploma or other qualification.

I further declare that this thesis is substantially my own work. Where reference is made to the works of others, the extent to which that work has been used is indicated and fully acknowledged in the text and list of references.

The dissertation is 16 324 words long (excluding the scanned items).

---

signature

Neda Samimi

\_thank you to:

\_Nouri, Lily and Erfan Samimi for the constant support, love and advice.

\_ Dr Laubscher, Prof. Bakker and Prof. Vosloo

\_my Bokunde friends

## abstract

This project stemmed from the idea of abandoned buildings prevalent in the City of Pretoria. It also responds to the increasing effect of environmental damage becoming evident worldwide.

As part of the solution, this dissertation explores the adaptive reuse of the existing Agrivaal Building in Pretoria, South Africa. The early Modern, Art Deco influenced Agrivaal Building has been left dormant for a number of years, with the intention of being renovated and brought to life. However political and sensitive debate has hindered the progress of the abandoned building. This project envisions the revival of the building, through an intervention that is mindful of pertinent environmental issues, as well as respecting existing cultural heritage.

The investigation includes principles of heritage and environmental sustainability, as main design informants of the proposed new headquarters of The European Commission in South Africa. This will entail research on the existing building and ways it can be appropriated to mitigate issues of environmental damage. The proposed intervention will also respond to the identity of the European Commission in a South African context.

# **\_contents**

---



_ Copyright Notice .....	III
_ Abstract .....	IV
_ List of figures.....	VII
<b>01_ Introduction.....</b>	<b>1</b>
1.1_ The Changing Environment.....	3
1.2_ Changes in the built environment.....	4
1.3_ Pretoria’s Potential.....	4
1.4_ Dormant buildings in Pretoria.....	5
1.5_ Defining the Problem.....	6
<b>02_ Design Planning_ review and reasoning.....</b>	<b>9</b>
2.1_ Problem Statement.....	10
2.2_ Hypothesis.....	10
2.3_ Main Research Question .....	10
2.4_ Sub Research Questions.....	10
2.5_ Vision.....	10
2.6_ Introducing the Client.....	11
<b>03_ Theoretical Discourse .....</b>	<b>17</b>
3.1_ Introduction.....	18
3.2_ Sustainability.....	19

3.3_Heritage .....	22
3.4_Adaptive Reuse .....	24
3.5 Current Stance and Application .....	26
<b>04_ Context .....</b>	<b>29</b>
<b>4.1_ Context .....</b>	<b>31</b>
4.1.1_Introduction .....	31
4.1.2_Location .....	31
4.1.3_Climatic Zone .....	32
4.1.4_Site Location .....	33
4.1.5_Legislative Context .....	39
4.1.6_ Urban Design .....	40
<b>4.2_Site Analysis .....</b>	<b>46</b>
<b>4.3_Building Analysis .....</b>	<b>52</b>
4.3.1 Agrivaal Building Phase 1 (1938) .....	54
4.3.2 Agrivaal Building Phase 2 (1946) .....	55
4.3.3 Agrivaal Building Phase 3 (1953) .....	55
4.3.4 Agrivaal Building Phase 4 (1963) .....	56
4.3.5 Analysis of special architectural elements of Cultural Significance .....	57
4.3.6 Statement of Significance.....	61
<b>05_ Precedent Study .....</b>	<b>65</b>
<b>06_ Client and Brief .....</b>	<b>79</b>

<b>07_Design Development .....</b>	<b>88</b>
<b>08_Technical Investigation .....</b>	<b>115</b>
8.1_Structure .....	116
8.2_Material Strategy .....	119
8.3_Systems - Ventilation, Heating and Cooling...	122
8.4_Façade Treatment .....	132
_References.....	148

## List of Figures:

Fig.1:Map indicating buildings that should be reused, retained or left neutral according to the Heritage Congress Mapping Workshop , [Source: Heritage Congress, 2009]	5
Fig.2:Fig.2:Adaptive reuse of dormant buildings [Source: author 2011]	6
Fig.3:Fig.4:European Union and South Africa Development Partners Logo [Source: European Union and South Africa, 2010]	11
Fig.4:Fig.3:President Zuma and EU Development and Humanitarian Aid Commissioner Karel de Gucht (representing European Commission President Jose Manuel Barroso) at the 2nd SA-EU Summit in Kleinmond, South Africa, in September 2009 [Source: European Union and South Africa, 2010:2]	11
Fig.5:Fig.5: Location of the Agrivaal Building, corner of Edmond Street and Hamilton Street [Source: Municipality of City of Tshwane, edited by author 2011]	12
Fig.6:Fig.6: 3D interpretation of the site [Source: author 2011]	12
Fig.7:Fig.7:Eastgate Shopping Centre, designed influenced by the workings of a termite hill. [Source: www.treehugger.com/files/2006/08/biometric_buil_1.php, accessed 2 October 2011]	21
Fig.8:Fig.9:Eastgate Centre elevation, with chimney vents allowing air to escape the building. [Source: www.nubianarchitects.wordpress.com/2010/08/16/termites-and-temperature-control-from-zimbabwe/, accessed 2 October 2011]	21
Fig.9:Fig.8: Ventilation [Source: www.treehugger.com/files/2006/08/biomimetic_buil_1.php, accessed 2 October 2011,edited by author 2011]	21
Fig.10:Fig.10:Process from the Burra Charter that assists in understanding the significance of the building. This process has been done for the Agrivaal Building under chapter 4, building analysis	23
Fig.11:Fig.11:Pie chart showing the percentage of average total embodied energy [Source: www.heritagefoundation.ca/docs/Energy_Waste_EN.pdf. accessed: March 2011]	24
Fig.12:Fig.12:Bar chart showing the recurring embodied energy of an office building [Source: www.heritagefoundation.ca/docs/Energy_Waste_EN.pdf. accessed: March 2011]	24
Fig.13:Fig.13:Interpretation of Fred Scott's theory on altering architecture [Source: author 2011]	25
Fig.14:Fig.14:A image portraying the architect as a major cause in changes in the environmnet. [Source: WELLS, p 272]	27
Fig.15:Fig.15:the world	30
Fig.16:Fig.16:Tshwane framework intensions [Source: City of Tshwane Municipality, edited by author 2011]	31
Fig.17:Fig.18:gauteng [Source: City of Tshwane Municipality, edited by author 2011]	31
Fig.18:Fig.17:South Africa [Source: City of Tshwane Municipality, edited by author 2011]	31
Fig.19:Fig.20:Wind driven ventilation system in Sutton, England. Wind cowls use the wind to draw warm stale air up from inside, and direct fresh air downwards over passive heat exchanger [Source: www.flickr.com/photos/8586443@N03/2377282168/in/photostream/ ]	32
Fig.20:Fig.19:solar water heaters utilizing solar energy to provide warm water [Source: www.solardev.com/FSEC-solar-heating.php, edited by author 2011]	32
Fig.21:Fig.21:concept sketch of recycled water system from green roof [Source: Author]	32
Fig.22:Fig.22:large roof space where areas will be for PV panels [Source: Author]	33
Fig.23:Fig.23:concept of proposed ventilation in the Agrivaal Building [Source: Author]	33
Fig.24:Fig.24:Position of the Agrivaal Building Source: City of Tshwane Municipality, edited by author 2011]	34
Fig.25:Fig.25:The Agrivaal Building, located on the corner of Hamilton Street and Edmond Street. [author:2011]	35
Fig.26:Fig.26:Agrivaal Building	37
Fig.27:Fig.27:Focus area for framework	40
Fig.28:Fig.28:Transport route [Source: author 2011]	42
Fig.29:Fig.29:View [Source: author 2011]	42
Fig.30:Fig.30:Facades of the Agrivaal Building [Source: author 2011]	46
Fig.31:Fig.32:Pedestrian and vehicular movement surrounding the Agrivaal Building	47
Fig.32:Fig.33:Height of buildings surrounding the Agrivaal Building	47
Fig.33:Fig.31:Massing of the Agrivaal Building and the surrounding Buildings	47
Fig.34:Fig.34:Bollards on sidewalks, however ending just before the Agrivaal Building [Source: author 2011]	48
Fig.35:Fig.37:High volumes of traffic at peak hours on Hamilton Street, photo taken on roof of the Agrivaal Building. [Source: author 2011]	48
Fig.36:Fig.35:Hamilton Street has four lanes, not very pedestrian friendly. [Source: author 2011]	48
Fig.37:Fig.38:Pine trees of heritage value on Edmond Street, Agrivaal Building located to the right of the photo. [Source: author 2011]	48
Fig.38:Fig.36:Narrow sidewalks [Source: author 2011]	48
Fig.39:Fig.39:Corner of Edmond and Hamilton Street, newspaper selling, proving high movement of customers. [Source: author 2011]	49
Fig.40:Fig.41:Hamilton Street, one way four lanes towards Sunnyside. [Source: author 2011]	49
Fig.41:Fig.40:Lack of parking on Hamilton Street, opposite the Agrivaal Building [Source: author 2011]	49
Fig.42:Fig.42:Commercial activity south of the Agrivaal Building, two blocks away. The Agrivaal Building has no commercial activity in it's surrounding. [Source: author 2011]	49
Fig.43:Fig.43: Building progression of the Agrivaal Building from 1938 to 1963 [Source: author 2011]	52
Fig.44:Fig.44: Clear distinction of different phases of the Agrivaal building due to material use. [Source: author 2011]	52
Fig.45:Fig.45: Different phases of the Agrivaal Building [Source: author 2011]	53
Fig.46:Fig.46:Corner articulation of the Agrivaal Building [Source: author 2011]	54

Fig.47:Fig.49:Phase 1 of the Agrivaal Building [Source: author 2011]	55
Fig.48:Fig.47:Phase 2 addition of the Agrivaal Building, 1946. [Source: author 2011]	55
Fig.49:Fig.48:Phase 3 addition of the Agrivaal Building, 1953. [Source: author 2011]	55
Fig.50:Fig.50:Phase 4 addition to the Agrivaal Building, 1963 Council Chamber. [Source: author 2011]	56
Fig.51:Fig.51:Glass blocks used to accentuate the corner articulation of the Agrivaal Building [Source: author 2011]	57
Fig.52:Fig.52:Main existing entrance, currently blocked by a brick wall. [Source: author 2011]	57
Fig.53:Fig.53:Lettering and the teak mask. [Source: author 2011]	58
Fig.54:Fig.54:Mural. [Source: author 2011]	58
Fig.55:Fig.55:Steel casement windows. [Source: author 2011]	58
Fig.56:Fig.58:Edmond Street framed with pine trees. [Source: author 2011]	59
Fig.57:Fig.56:Paving with Kirkness insignia. [Source: author 2011]	59
Fig.58:Fig.57:Pines trees from the landscaping plans of the Union Building [Source: author 2011]	59
Fig.59:Fig.59:Phase 3, with exposed brick. [Source: author 2011]	60
Fig.60:Fig.60: and	66
Fig.61:Fig.61:CH2 Building [Source: www.melbourne.vic.gov.au/Environment/CH2/]	66
Fig.62:Fig.67:Timber shutters and glass louvres. [Source: www.melbourne.vic.gov.au/Environment/CH2/]	67
Fig.63:Fig.62:Vertical garden [Source: www.melbourne.vic.gov.au/Environment/CH2/]	67
Fig.64:Fig.66:Lighting and Shading[Source: www.melbourne.vic.gov.au/Environment/CH2/]	67
Fig.65:Fig.63:wind cowl assisting in ventilation [Source: www.melbourne.vic.gov.au/Environment/CH2/]	67
Fig.66:Fig.64:and	67
Fig.67:Fig.65:timber louvers [Source: www.melbourne.vic.gov.au/Environment/CH2/]	67
Fig.68:Fig.68:CH2 in Summer Mode [Source: www.melbourne.vic.gov.au/Environment/CH2/]	68
Fig.69:Fig.69:Heating and Cooling through the Cieling[Source: www.melbourne.vic.gov.au/Environment/CH2/]	68
Fig.70:Fig.71:Vertical Garden and Balcony Condition. [Source: www.melbourne.vic.gov.au/Environment/CH2/]	69
Fig.71:Fig.70:CH2 in Winter Mode [Source: www.melbourne.vic.gov.au/Environment/CH2/]	69
Fig.72:Fig.72:and	70
Fig.73:Fig.73: Harmonia 57 Office Building	70
Fig.74:Fig.76:Pipes that form part of the water recycling system in Harmonia 57 [Source: <a href="http://www.architonic.com/aisht/harmonia-57-triptyque-architecture/5100477">http://www.architonic.com/aisht/harmonia-57-triptyque-architecture/5100477</a> ]	71
Fig.75:Fig.74:Water recycling system of Harmonica 57. [Source: <a href="http://www.architonic.com/aisht/harmonia-57-triptyque-architecture/5100477">http://www.architonic.com/aisht/harmonia-57-triptyque-architecture/5100477</a> ]	71
Fig.76:Fig.77:Accessible roof [Source: <a href="http://www.architonic.com/aisht/harmonia-57-triptyque-architecture/5100477">http://www.architonic.com/aisht/harmonia-57-triptyque-architecture/5100477</a> ]	71
Fig.77:Fig.75:Proposed recycle sytem for the Agrivaal Building, using the Harmonia and Central Saint Giles building. [Source: <a href="http://www.architonic.com/aisht/harmonia-57-triptyque-architecture/5100477">http://www.architonic.com/aisht/harmonia-57-triptyque-architecture/5100477</a> , edited by author 2011]	71
Fig.78:Fig.78:3D renderings envisioned by architects [Source: <a href="http://www.architonic.com/aisht/harmonia-57-triptyque-architecture/5100477">http://www.architonic.com/aisht/harmonia-57-triptyque-architecture/5100477</a> ]	71
Fig.79:Fig.79:VIP drop off point [Source: www.bdp.com/Projects/By-Name/P-Z/Umoja-House/]	72
Fig.80:Fig.80:night view [Source: www.bdp.com/Projects/By-Name/P-Z/Umoja-House/]	72
Fig.81:Fig.81:Main entrance of Umoja House	72
Fig.82:Fig.83:Access points at the Umoja House[Source: www.bdp.com/Projects/By-Name/P-Z/Umoja-House/]	73
Fig.83:Fig.82:louvers, fencing, roof.[Source: www.bdp.com/Projects/By-Name/P-Z/Umoja-House/]	73
Fig.84:Fig.84:Turbine Hall [Sourced: www.conference-venues.co.za/gjhb_forumturbine.htm]	74
Fig.85:Fig.88:Existing steel bunker. [Source: author]	75
Fig.86:Fig.89:New glass partitioning with aluminium frames. [Source: author]	75
Fig.87:Fig.85:g Gass box inside concrete shell [Source: author]	75
Fig.88:Fig.86:New ballustrade connected to existing coloumn. [Source: author]	75
Fig.89:Fig.87:Plaque: information of the heritage of the building. [Source: author]	75
Fig.90:Fig.90: Detail of ceramic solar shading structure. [Source: <a href="http://www.architectmagazine.com/exteriors">http://www.architectmagazine.com/exteriors</a> ]brandhorst-museum.aspx	76
Fig.91:Fig.91: Section showing position of shading system [Source: <a href="http://www.arcspace.com/architects/pianoNYT/">http://www.arcspace.com/architects/pianoNYT/</a> ]	76
Fig.92:Fig.92: Entrance of the New York Times Building [Source: www.arcspace.com/architects/piano/NYT/]	77
Fig.93:Fig.93:Lobby Entrance [Source: www.newyorktimesbuilding.com/ Photograph by Kenzo Hsieh (HSUEH-HSIEN HSIIEH), 2007.]	77
Fig.94:Fig.94:Lobby Entrance [Source: www.newyorktimesbuilding.com/ Photograph by Kenzo Hsieh (HSUEH-HSIEN HSIIEH), 2007.]	77
Fig.95:Fig.95: and	77
Fig.96:Fig.96: [Source: www.arcspace.com/architects/piano/NYT/]	77
Fig.97:Fig.97:European Union flags outside the European Commission headquarters building in Brussels, Belgium. [Source: www.royalgazette.com/article/20110623/BUSINESS04/706239907&source=RSS]	80
Fig.98:Fig.98:diagram indicating the function of the EC in South Africa [Source: www.eusa.org.za/]	81
Fig.99:Fig.99: Diagram showing a proposed view on how the EC want to be perceived in South Africa [Source: author]	82
Fig.100:Fig.100: Simplified diagram on the needs of the new building [Source: author]	82
Fig.101:Fig.101: Diagram showing the users of the uilding [Source: author]	83
Fig.102:Fig.102:Diagram of proposed wasys the poeple will enter the building [Source: author]	84
Fig.103:Fig.103:Diagram of concept, Sustainable Heritage [Source: author]	89
Fig.104:Fig.104:Diagram showing the needs of the user	90
Fig.105:Fig.105: open plan office	92



Fig.106:Fig.106: partitioned group offices layout	92
Fig.107:Fig.107:cubicle- semi enclosed	92
Fig.108:Fig.108: private office	92
Fig.109:Fig.109: private shared office	92
Fig.110:Fig.110:private shared office	92
Fig.111:Fig.111: partitioned work space	92
Fig.112:Fig.112: quick work point	92
Fig.113:Fig.113:small boardroom	92
Fig.114:Fig.114: large boardroom	93
Fig.115:Fig.115:small meeting space	93
Fig.116:Fig.116:large meeting space	93
Fig.117:Fig.117: boardroom facilities	93
Fig.118:Fig.118: quick meeting point	93
Fig.119:Fig.119: xerox room	93
Fig.120:Fig.120: filing space	93
Fig.121:Fig.121: storage space	93
Fig.122:Fig.122: locker area	93
Fig.123:Fig.123: coffee/tea area	93
Fig.124:Fig.124: waiting area	93
Fig.125:Fig.125:smoking room/area	93
Fig.126:Fig.126:proposed ground floor [Source: author]	95
Fig.127:Fig.127:proposed first floor [Source: author]	95
Fig.128:Fig.128:proposed second floor [Source: author]	95
Fig.129:Fig.129:First line of defence, the boundary fence [Source: author]	96
Fig.130:Fig.130:different security zones in the building [Source: author]	96
Fig.131:Fig.131:Existing plan of the Agrivaal Building	97
Fig.132:Fig.132:Parti diagram	97
Fig.133:Fig.133:Existing Agrivaal Building [Source: author]	98
Fig.134:Fig.134:The Link between the courtyard building and the 'new building' [Source: author]	98
Fig.135:Fig.135:Auditorium and addition to council chamber [Source: author]	99
Fig.136:Fig.136:Proposed concept for Agrivaal Building [Source: author]	99
Fig.137:Fig.137:Design development [Source: author]	100
Fig.138:Fig.138:View of new southern facade [Source: author]	100
Fig.139:Fig.139:Sketch showing the concept of boundary fencing and entrance [Source: author]	101
Fig.140:Fig.140:Southern view of the proposed Agrivaal Building as seen on Edmond Street [Source: author]	101
Fig.141:Fig.141:Site Plan	104
Fig.142:Fig.142:Typical Basement Plan	105
Fig.143:Fig.143: VIP Entrance Plan	106
Fig.144:Fig.144: Ground Floor Plan	107
Fig.145:Fig.145: First Floor Plan	108
Fig.146:Fig.146: Second Floor Plan	109
Fig.147:Fig.147: Third Floor Plan	110
Fig.148:Fig.148: Roof Plan	111
Fig.149:Fig.149: Section A-A	112
Fig.150:Fig.150: Section B-B	113
Fig.151:Fig.151: South Elevation	114
Fig.152:Fig.152: North Elevation	115
Fig.153:Fig.153:New and existing structure. [Source: author]	116
Fig.154:Fig.154: New and existing structure	117
Fig.155:Fig.155: New concrete structure [Source: author]	118
Fig.156:Fig.156: Steel column, rectangular hollow profile with two steel channels welded to opposite sides. [Source: author]	118
Fig.157:Fig.157: CONCEPT sketches of steel details, drawings not to scale. [Source: author]	118
Fig.158:Fig.158: Terrazzo Cladding	119
Fig.159:Fig.159: Clay Bricks	119
Fig.160:Fig.160: Existing Parquet Flooring	119
Fig.161:Fig.161: Steel railing	119
Fig.162:Fig.162: GKD mesh	119
Fig.163:Fig.163: Mentis Grid	119
Fig.164:Fig.164: Steel	119
Fig.165:Fig.165: Stainless steel cables	119
Fig.166:Fig.166: Safety glass	119
Fig.167:Fig.167: Laminated glass	119
Fig.168:Fig.168: Toughened glass	119
Fig.169:Fig.169:Timber flooring	119
Fig.170:Fig.170:Reused parquet flooring	119

Fig.171:Fig.171: Concrete	119
Fig.172:Fig.172: Ventilation system. [Source: author]	123
Fig.173:Fig.173: Trombe assisted solar chimney . [Source: author]	123
Fig.174:Fig.175: Warm air production, internal workings of stack, front view. [Source: author]	124
Fig.175:Fig.176: Warm air production, internal workings of stack connected to parabolic heat collector, side view [Source: author]	124
Fig.176:Fig.177: Cool air production, internal workings of stack front view. [Source: author]	125
Fig.177:Fig.178: Cool air production, internal workings of stack B, side view	125
Fig.178:Fig.179:Southern façade stack - top condition	126
Fig.179:Fig.180: Southern façade stack - middle condition	127
Fig.180:Fig.182:Exterior appearance of southern façade stack	128
Fig.181:Fig.181:Plan of southern façade stack	128
Fig.182:Fig.183:Section through Trombe Assisted Solar Chimney - top condition	129
Fig.183:Fig.184:Section through Trombe Assisted Solar Chimney - middle condition	130
Fig.184:Fig.186:Exterior appearance of Trombe Assisted Solar Chimney	131
Fig.185:Fig.185:Plan of Trombe Assisted Solar Chimney	131
Fig.186:Fig.187: GKD mesh, Woven-in bar with spring, top and middle attachments [Source: www.gkdmalfabrics.com/pdf/attachments/woven-in_bar_with_spring.pdf, accessed 2 October 2011]	132
Fig.187:Fig.188: GKD mesh, Woven-in bar with spring [Source: www.gkdmalfabrics.com/pdf/attachments/woven-in_bar_with_spring.pdf, accessed 2 October 2011]	132
Fig.188:Fig.189:3D representation of proposed stack and screen south facade. [Source: author]	133
Fig.189:Fig.190:Exploded image of screen. [Source: author]	133
Fig.190:Fig.191:Steel connections for screen. [Source: author]	134
Fig.191:Fig.192:Screen detail with GKD mesh fixing. [Source: author]	135
Fig.192:Fig.193:Light shelf concept [Source: author]	136
Fig.193:Fig.196:Night purge openings [Source: author]	136
Fig.194:Fig.194:Balconies [Source: author]	136
Fig.195:Fig.195:Manually controlled blinds [Source: author]	136
Fig.196:Fig.197:North facade existing condition with no solar protection [Source: author]	137
Fig.197:Fig.198: Table of solar angles in Pretoria [Source: Napier,2000]	137
Fig.198:Fig.199: 21 June, Winter, solar angle condition at 08h00 and 16h00 ( solar angle at 14 degrees) [Source: author]	138
Fig.199:Fig.200: 21 June, Winter, solar angle condition at 12h00 (solar angle at 40 degrees) [Source: author]	138
Fig.200:Fig.201: 21 December, Summer, solar angle condition at 08h00 and 16h00, (solar angle at 35 degrees) [Source: author]	139
Fig.201:Fig.202: 21 December, Summer, solar angle condition at 12h00, (solar angle at 88 degrees) [Source: author]	139
Fig.202:Fig.203: Northern Facade Treatment	140
Fig.203:Fig.204: Plan of North Facade Treatment	140
Fig.204:Fig.206:Light shelf fixing to wall	141
Fig.205:Fig.205:Northern Facade Treatment, new balcony and light self detail	141
Fig.206:Fig.207: Plan of Pergola	142
Fig.207:Fig.208: Section of Pergola	142
Fig.208:Fig.209: Section of Glass Stairs	143
Fig.209:Fig.210: Detail of Stairs	143
Fig.210:Fig.211: Plan of Stairs	144
Fig.211:Fig.212: Balustrade Detail	144
Fig.212:Fig.213: Proposed recycle water cycle for the Agrivaal Building	145

# chapter 01

## introduction

---

“  
*To create sustainable architecture you have to listen to the users.*

*E.D. Melet*



# 01\_introduction

In architecture, adaptation for new use is not a new phenomenon; buildings have been re-used throughout history (John, 2008:1). The Baths of Diocletian in Rome were converted into the Santa Maria degli Angeli Church by Michelangelo in 1566, and the Hagia Sofia in Istanbul, Turkey, was once a church (360-1453) which was later converted to a mosque (1453-1931), and is at present functioning as a museum (Adams, 2002:295). Currently, new and sensitive architectural interventions are regarded as an inventive way to breathe new life into an existing historical layer of the city, whilst contributing to economic and social value (John, 2008:1). The marriage of new and old architecture brings life to a building while providing an appropriate new use. This will eventually add to the building's historical fabric as well as contribute to the urban landscape.

To re-use an existing building retains a certain amount of the existing embodied energy, which otherwise would be completely wasted. Thus a project is enabled to take an environmentally sustainable stance as opposed to an entirely new constructed building. The current increase in climate change and economic pressure globally has affected the earth negatively. It is evident that if the world continues with its careless attitude, greater deterioration will steal the 'mundane' and turn them into luxuries.

This project will investigate the re-use of an existing building in which the mitigation of negative environmental impact, and respect for cultural value will be explored.

## 1.1 THE CHANGING ENVIRONMENT

The earth is experiencing rapid urban sprawl and population growth. Most of the future growth of urban populations is anticipated in the developing world (Wilby, 2003:1).

By 2005, the average global temperature was 0.76 °C above the level in pre-industrial times, according to the UN Intergovernmental Panel on Climate Change (IPCC). The panel projects that the earth is likely to warm by a further 1.8°-4 °C this century, and in the worst case scenario by as much as 6.4°C, unless the world acts to cut Green House Gas emissions (GHG) (EU Climate Action, 2010:2).

In many developing countries, climate change is not a pressing factor; the focus rather falls on economic development. Poverty is exacerbated by the impacts of environmental change, and in turn by the deterioration of the landscape.

South Africa is awakening to the shift in paradigm. According to the Department of Environmental Affairs, “changes in climate already affect various sectors of South African society and the economy as well as the biophysical environment, and the effects are predicted to be significant in future. The areas of highest vulnerability are the health sector, maize production, biodiversity, water resources, and rangelands” (South Africa. Department of Environmental Affairs, 2010:1). A National Climate Change Response Strategy for South Africa was compiled in 2004, which aimed to address issues identified as priorities for dealing with climate change in the country (South Africa. Department of Environmental

Affairs, 2010). The Kyoto Protocol was adopted on 10 December 1997. It aims to reduce the effects of climate change by reducing the emissions of six greenhouse gases (South Africa. Department of Environmental Affairs, 2010). However, South Africa is regarded as a developing country and signing documents to be part of the international effort to mitigate climate change does not bind the country to follow all the requirements. Thus, these protocols and treaties are rather superficial in terms of implementation in the country.

According to the Department of Environmental Affairs, it has been predicted that by 2050 the coastal areas of South Africa will warm by around 1-2°C, and the interior by around 2-3 °C (2010:5). Certain areas of the country will be much drier, and increased evaporation will cause an overall decrease in water availability, significantly affecting human health, agriculture and the environment in general (South Africa. Department of Environmental Affairs, 2010:5). Given the significance of these impacts, it is clear that urgent and decisive international and local action is required to achieve a real reduction in greenhouse gasses.

Radical changes on earth require radical changes in society. The built environment is particularly implicated in the changing conditions, and should be a prime target in the war against catastrophic climate change (Smith, 2001:ix). If the built environment is a large contributing factor to the deterioration of the environment, it is heavily implied that architects have a specific role to play in protecting the environment.

## 1.2 CHANGES IN THE BUILT ENVIRONMENT

Global warming is unequivocal and it is very likely that the increase in anthropogenic greenhouse gas concentrations is responsible for the increase in temperature since the mid twentieth century (South Africa. Department of Environmental Affairs, 2010:4). “South Africa is both a contributor to, and potential victim of global climate change given that it has an energy-intensive, fossil-fuel powered economy and is also highly vulnerable to the impacts of climate variability and change” (South Africa. Department of Environmental Affairs, 2010:4).

In an era when climate change and construction processes are costly, a city cannot afford to ignore buildings that potentially have historical and cultural value that may contribute to the rich layers of the city. Jane Jacobs, writing on urban planning and decay, argues in her seminal work *The Death and Life of Great American Cities* that “if a city has only new buildings, the enterprises that can exist are automatically limited to those that can support the high costs of a new construction” (1993:200). She further emphasizes that “time makes certain structures obsolete for some enterprises, and they become available to others. Time can make the space efficiencies of one generation the space luxuries of another generation. One century’s building commonplace is another century’s useful aberration” (Jacobs, 1993:202).

“Buffeted by economic uncertainty, globalization, and disruptive technologies, architects today have more questions than answers” (Pearson, 2011:20). It is clear that changes in lifestyle are imminent in society. Environmental issues have affected all parts of society, including the built environment. Many questions are being asked without being answered. There is a sense of uncertainty in terms of what the future will bring, especially if the world continues in its materialistic, competitive manner.

“Can design change the world?” or rather, “Is the world changing design?” Warren Burger’s approach is, “What design actually can do [is], solve problems on a case-by-case basis around the world (2009:2). As it does that, it changes the world, because it changes the reality for people wherever the situation is happening” (2009:2). The approach of this thesis is to understand the specific problems of the project and apply this understanding through architecture. This enables a building to function successfully, while respecting and contributing to its

urban environment. Every building designed responsibly is a “case-by-case” step forward.

A starting point in the built environment is the recycling of buildings. Existing structures are re-used consistently in first world countries, taking advantage of prime location, finances and an existing structure to work with. South Africa is currently taking to the idea of recycled buildings, with well-known examples such as Turbine Hall in Newtown, Johannesburg.

There are two possible scenarios concerning an abandoned building intended for re-use. Firstly, a building can be sold or rented to a new company, then retrofitted or adapted to suit specific needs. The second scenario leaves the building abandoned and thus ‘dormant’ for years to come. In a city, the latter poses issues of security, expense and wasted space. The abandoned building’s embodied energy has now gone to waste and is not contributing to the city; it is deemed unsustainable.

## 1.3 PRETORIA’S POTENTIAL

A dormant building can be defined as an abandoned or unused building that is not currently operational.

The City of Tshwane was established in 1855 (Holm, 1998:61) and is considered a young city, yet a number of buildings are dormant in the Central Business District (CBD) and its surroundings. This gives the impression of deteriorating urban areas. Abandoned buildings can be found in many cities in the world, and it is uncommon that the City of Tshwane has such a high number of abandoned buildings. What happens to these abandoned buildings will determine the future of the surroundings and the city at large.

Abandoned buildings provide opportunities for interventions that can breathe life into these dormant shells and their surrounding areas. The architectural history of the City of Tshwane relates to the pre-Modern era, Modernism and Post-Modernism. Many of these dormant buildings have value in their architectural expression, allowing for interventions that can draw on a rich heritage.

## 1.4 DORMANT BUILDINGS IN PRETORIA

Mapping studies were conducted during the Heritage Congress in 2009 as part of research on buildings in the City of Tshwane. The mapping expresses issues concerning the quality of building stock in the city. This includes, buildings that can be re-used, altered, demolished and buildings of heritage value.

The Agrivaal Building has been identified as the proposed site for this dissertation. According to the information gathered by the mapping exercises the Agrivaal is a deteriorating abandoned building, which does not respond to its surroundings. Majority of the surrounding buildings have been classified as 'neutral', implying that the buildings are in good working condition and contributing to the urban fabric.

This dissertation proposes to house the new Delegation of the European Commission (EC) for South Africa in the Agrivaal Buildings because:

- The building is located on the 'Government Boulevard' identified in the ReKgabisa Framework, which will be analyzed in a later chapter.
- It is located close to the Union Buildings, symbolically important in terms of the position of the New EC Headquarters
- It is located on a street that has a number of office buildings
- The building's scale and surrounding space allows for an appropriate intervention for this dissertation

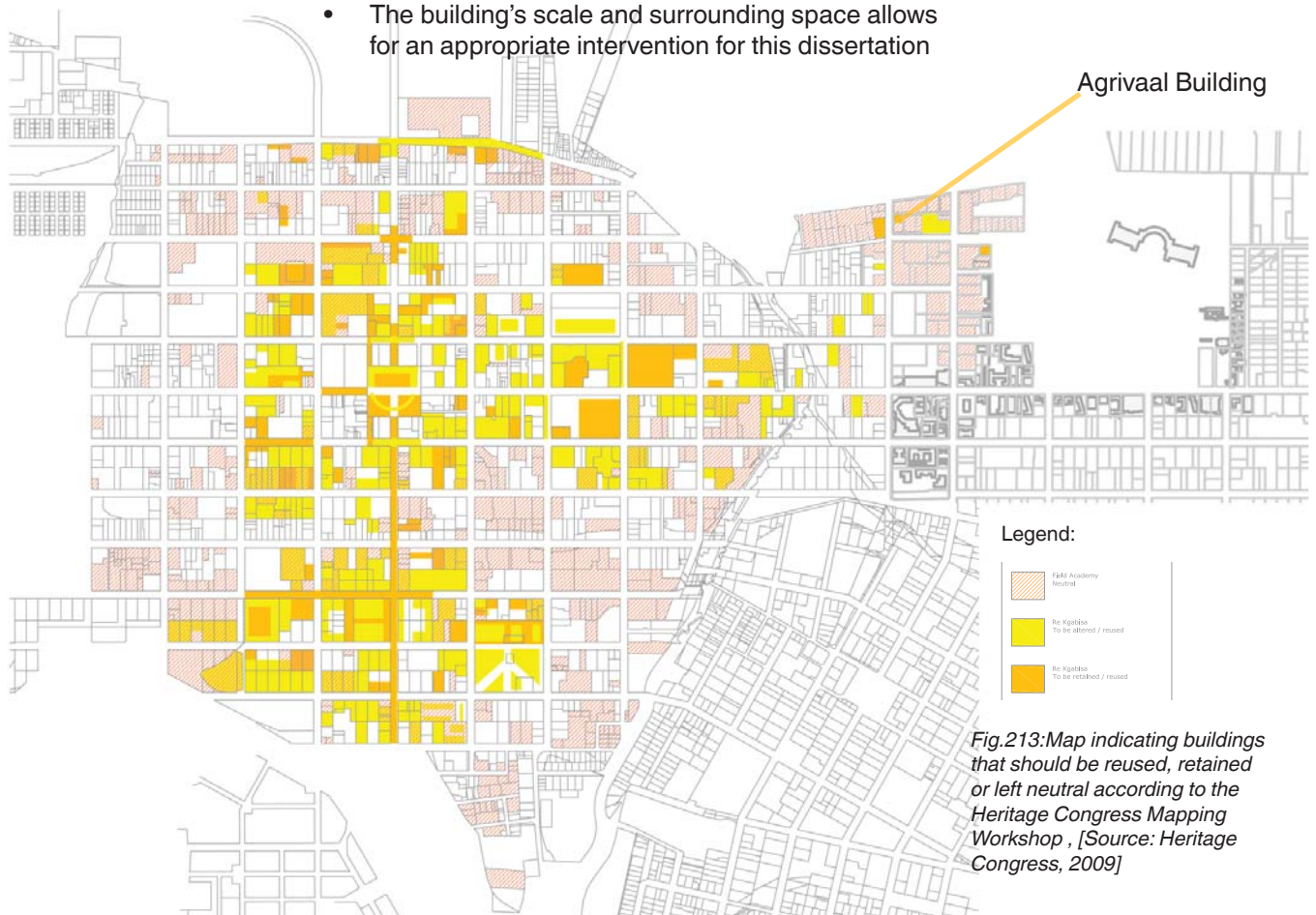

Fig.213:Map indicating buildings that should be reused, retained or left neutral according to the Heritage Congress Mapping Workshop , [Source: Heritage Congress, 2009]

## 1.5 DEFINING THE PROBLEM

This section will define the problems, aim and research methodology concerning the Agrivaal Building. The refined and focused 'problem statement' will feature in the following chapter.

### 1.5.1 PROBLEM

- A dormant building implies waste of space, materials, and a building that does not contribute to the urban fabric.
- Changes in environmental, social, political and economic settings bring about a need for self sufficiency, adjustment, flexibility, and consideration in the built environment. Thus, an architectural response in terms of change must be investigated. In this project, responding to change will encompass the needs of the existing Agrivaal Building. A focus on sustainability, heritage, security issues, client demands and the brief are amongst the issues that will guide the design process.
- The appropriate and respectful representation of the European identity within the South African context.

### 1.5.3 THE AIM OF THE STUDY

This study aims to investigate the reuse of an old dilapidated building that can be revived, and thus respond and contribute positively to the urban landscape. The investigation will include expression of the principles of sustainability and respect towards existing heritage.

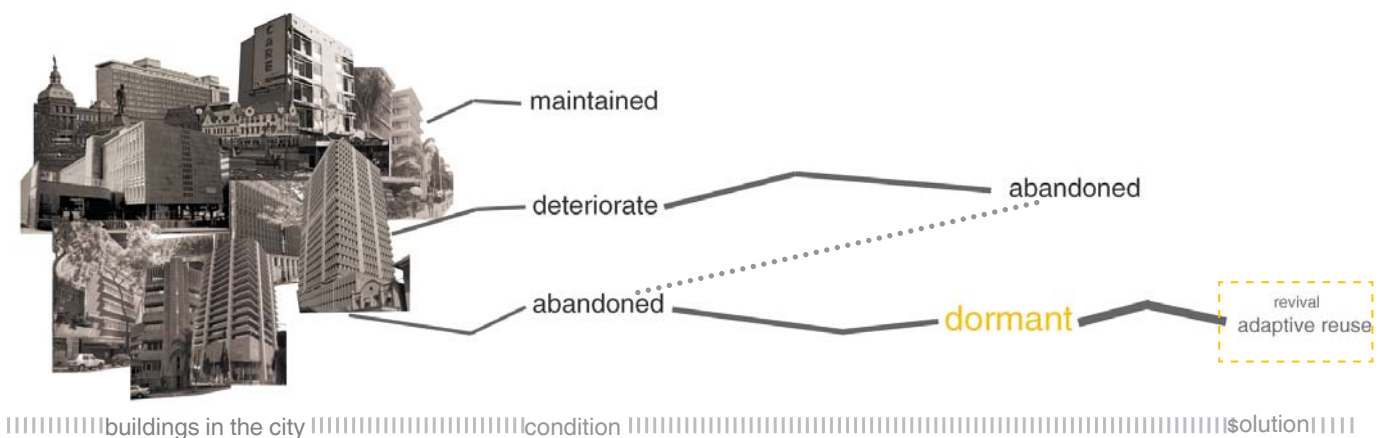

Fig.214: Adaptive reuse of dormant buildings [Source: author 2011]

## 1.5.4 RESEARCH METHODOLOGY

This project will investigate two main theories concerning sustainability and adaptive re-use. These will be consolidated with the Green Star Office Manual and rating tool, as well as the standard SBAT tool, allowing for more insight and detail on environmental issues. Heritage charters such as the Burra Charter will be used as a guiding heritage tool, providing an international standard for dealing with buildings of sensitive cultural significance. Other investigations were conducted for the design (e.g. context study, programme, client needs etc.)

### **\_theoretical investigation**

#### **\_theoretical focus**

##### **theory 01\_sustainability:**

*focus:* Ecological Design and Construction

*summary:* The concept of ecological design and construction is based on the systems of nature. It emulates biomimicry, where systems in nature are adapted and applied to architecture.

##### **theory 02\_adaptive reuse:**

*focus:* 'Altering Architecture'

Alteration, Adaptation and Adjustment

*summary:* Fred Scott's (Scott 2008:11) idea of alteration offers an alternative to preservation or demolition, a more general strategy to keep buildings extant beyond their time, enabling them to be inhabited and occupied. Sensitivity to existing architecture and surroundings are part of the alteration, adaptation and adjustment of a building or space.

#### **\_observation:**

Research through observation was conducted by means of gathering information of the study area. Information gathered allowed for the development of a framework to which the project responds to. The site and existing building was documented during numerous site visits, providing information for the re-drawing of the plans of the existing building and surrounding outbuildings, as original plans were not released from the Department of Public Works. Exploration and comprehension of the site contours were documented.

Information was obtained on security, traffic and pedestrian patterns, as were details of existing sun patterns, tree positions and material use.

#### **\_mapping:**

As a member of the Heritage Congress Mapping Workshop, mapping was conducted on buildings in the City of Pretoria. Buildings were categorised based on the condition of the buildings and thus identifying places where improvement can be focused on. The Agrivaal was zoned as an abandoned building.

#### **\_precedent studies:**

Information and understanding was gained by studying precedents on issues of environmental sensitivity and adaptive re-use of existing buildings. Other precedents focused on more detailed parts of design, such as water recycling, contrast between 'old' and 'new' architecture, heating and cooling etc.

# chapter 02

---

design planning: review and reasoning



# 02\_design planning

## 2.1 PROBLEM STATEMENT

Evidence exists of the repercussions of population increase, urban sprawl and climate change, causing concern for the future environmental condition (Dodman, 2009:1). The built environment community is one part of society that can play a major role in the mitigation of environmental damage.

In terms of architecture, adaptive re-use must facilitate the sustainable regeneration of dormant buildings, thus enabling these to respond to the urban landscape and contribute to sustainable urban growth. Proof of the success of utilising old buildings for new uses can be seen in developed countries such as Holland and Australia.

The goal of this project is to show that the **adaptive reuse of an existing building** that demonstrates the points below:

- beneficial and adapted to the client's NEEDS and IDENTITY
- to use principles that are sensitive to the existing building and the environment
- to provide a working design that contributes to the urban fabric

## 2.2 HYPOTHESIS

The adaptive re-use of a dormant building is inspired by the need for space, the relationship between function and space, accommodation requirements, and processes that will occur in the building. It is also informed by principles of sustainability and heritage.

## 2.3 MAIN RESEARCH QUESTION

Can the dormant Agrivaal Building be adaptively reused to serve the needs of the new European Commission in South Africa?

## 2.4 SUB RESEARCH QUESTION

1. What is a dormant building?
2. Why is the Agrivaal Building dormant?
3. What is adaptive re-use?
4. How will the European Commission be represented in a contemporary South African context?

## 2.5 VISION

This dissertation envisions the adaptive re-use of an existing modern building in an attempt to contribute to the mitigation of the changes in the environment, i.e. climate change, population change and economic pressure. Its heritage value must be commemorated and must contribute to the historical memory of the city. The building must relate to its surroundings, allowing public interaction as well as secure offices for the European Commission.

The chosen site, the Agrivaal Building, is an unused and derelict government building. It was previously used as the headquarters of the Maize Board, which regulated the sale of all maize produced in South Africa. It was the only legal buyer of maize from farmers and set the price paid to farmers each season. It is no longer in use and wasn't a priority for development until 2008/9. A classified proposal was put forth to the Department of Public Works concerning new offices for an unnamed company. However, to date very little has physically materialized. Subsequently the Agrivaal lies dormant.

The Agrivaal Building represents architectural progressiveness in the design of the original two phases, and the 1963 Council Chamber displays the consolidation of power in Nationalist South Africa. The building is part of a historical and cultural landscape that has value and adds richness and layering to the urban fabric of the precinct and Pretoria.

This dissertation will focus on the adaptive re-use of the Agrivaal Building. The design will be informed by theoretical premises of sustainability, heritage and adaptation. The architectural intervention intends to demonstrate virtues of climatic responsiveness. The program, the headquarters of the European Commission in South Africa, is also a major informant of design, as the link between South Africa and a European organization needs to be expressed in a South African context.



## 2.6 INTRODUCING THE CLIENT

The Delegation of the European Commission  
for South Africa

The Delegation of the European Commission (EC) is currently located in Pretoria, on George Storrar Drive in Groenkloof. This is in close proximity to a number of embassies in Pretoria, namely those in Arcadia, Hatfield and Brooklyn. However, the problem for the client is not the location of the building, but rather the need for more functional space. The current premises consist of a number of detached buildings on the property. The main concern is that different departments need to be housed in one building, thus assisting in the accessibility and inter-dependence of the different departments. Additional concerns include the lack of a large meeting space, where dignitaries, heads of states and members of parliament can convene with the EC, and a need for communal ‘rest’ areas, where staff can relax, communicate and brainstorm.

### 2.6.1 CLIENT’S ROLE IN SOUTH AFRICA

According to the EU publication on ‘European Union and South Africa’ (2009), the Delegation provides humanitarian, political and trade assistance in the country. The EU is South Africa’s largest trading partner. Economic co-operation covers both private and public sector activities. Capital investment takes place in both directions, both from and into South Africa.

Much of the focus is on poverty alleviation. The EU is South Africa’s largest donor, committing over R 1 billion per annum in three focal areas: Social Development, Economic Development and Governance Programs



Fig.216:European Union and South Africa Development Partners Logo  
[Source: European Union and South Africa, 2010]

designed in close co-operation with the Government (EU, 2009).

### 2.6.2 CLIENT’S BRIEF

- \_all departments to be housed in one building
- \_security
- \_additional offices for each department
- \_meeting rooms for each department
- \_large meeting space for convening EU
- \_representatives and other larger meetings
- \_canteen
- \_coffee shop
- \_storage areas



Fig.215:President Zuma and EU Development and Humanitarian Aid Commissioner Karel de Gucht (representing European Commission President Jose Manuel Barroso) at the 2nd SA-EU Summit in Kleinmond, South Africa, in September 2009 [Source: European Union and South Africa, 2010:2]

### 2.6.3 INTRODUCTION TO THE SITE



The proposed site is located on the corner of Edmond Street and Hamilton Street. Chapters 4 and 5 will provide an in-depth context and site analysis.



Fig.217: Location of the Agrivaal Building, corner of Edmond Street and Hamilton Street [Source: Municipality of City of Tshwane, edited by author 2011]

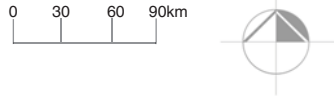

Fig.218: 3D interpretation of the site [Source: author 2011]



## 2.6.4 DELIMITATIONS

This study will specifically investigate ‘dormant’ buildings in the City of Pretoria. The choice of building was narrowed down to the Agrivaal Building. However, virtues of sustainability and heritage can be applied to many other buildings and should be part of all design interventions.

## 2.6.5 ASSUMPTIONS

It is assumed that the government will grant the permission of the use of the site on of merits of regeneration of government buildings and the inner city renewal as identified by the Re-Kgabisa framework.

## 2.7 OBJECTIVES

- Revitalize the Agrivaal Building, to contribute to and activate the surrounding urban fabric
- Respond to sustainable architectural issues
- Enhance and commemorate the heritage value of the existing building
- Achieve an iconic and contemporary building that is indicative to the European Union image but respectful of the contemporary South African context
- Provide a platform where interaction between of the European Commission and the South African government, non-governmental organizations, and the public can convene.
- Provide private, secure office space for the delegates of the European Commission
- Create a public realm: an informative, educational ‘rest point’ in the city

## DEFINITIONS



### **recycling\_**

1. to convert into usable material
2. to return to a previous stage in a cyclic process



### **dormant\_**

1. alive but not actively growing.
2. temporarily devoid of activity
3. temporarily in abeyance capable of being activated
4. to be asleep



### **cultural heritage\_**

1. the things, places and practices that define who we are as individuals, as communities, as nations or civilisations and as a species. It is that which we want to keep, share and pass on (University of Canberra, 2009)



### **sustainability\_**

1. sustainability is the long-term maintenance of well being, which has local and global action on environmental, economic, and social dimensions as inseparable and interdependent components of human progress (European Commission Environment, 2009)



### **sustainable heritage\_**

1. the use of principles pertaining to sustainability and cultural heritage.
2. coexistence of the principles of sustainability and cultural heritage



### **cultural significance\_**

1. The Australia ICOMOS Burra Charter, refers to cultural significance as “aesthetic, historic, scientific or social value for past, present or future generations” (The Australia ICOMOS Burra Charter, 1999:1).

### **conservation\_**

1. All the processes of looking after a place so as to retain its cultural significance (The Australia ICOMOS Burra Charter, 1999:2).

### **adaptation\_**

1. modifying a place to suit the existing use or a proposed use.

# chapter 03

## theoretical discourse

---

*“The hard facts of ‘sustainable’ development are that humans are totally dependent upon the green world – on living plants – for survival. Plants are the primary producers upon which all higher organisms are dependent.... On the other hand, plants do not need higher organisms such as humans to survive. They can survive – thrive, actually – without us.”*

*(Wells, 2003:271)*

# 03\_theoretical discourse

## 3.1\_INTRODUCTION

What follows is the theoretical approach of this project. It will discuss the meaning, intension and application of 'sustainability', 'heritage' and 'adaptation'. As part of this theoretical investigation, the author poses questions which intend to be rhetorical. However an answer is given based on this theoretical investigation and the author's normative position.

Question: What is the role of architecture in era of environmental change? Can architecture really influence the world in its current environmental state?

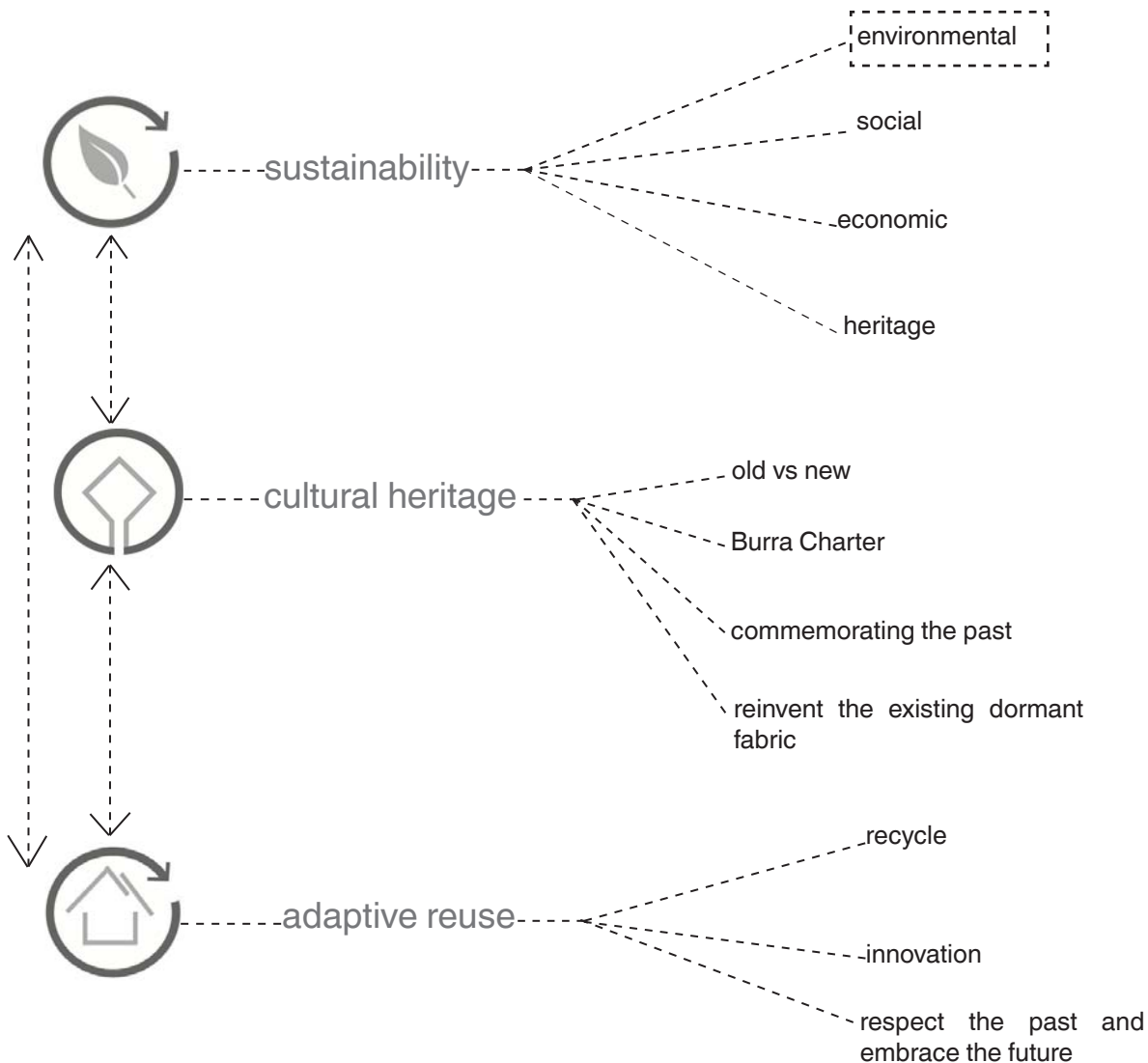

## theoretical intension for the Adaptive Reuse of the Agrivaal Building

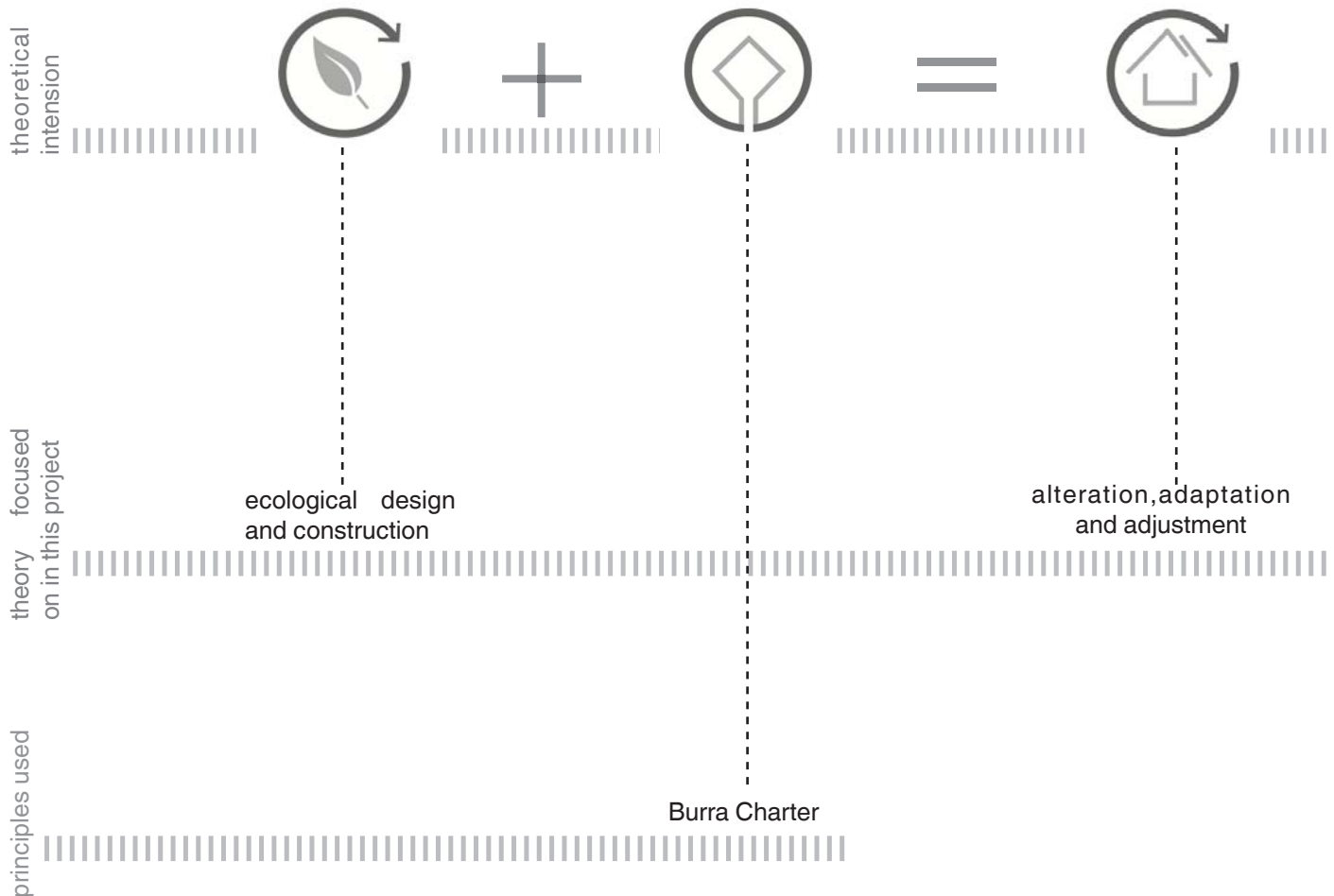

### 3.2 SUSTAINABILITY

Warnings have been given on the consequences of modern society's ignorance of its actions (Wells, 2003:268). Reports from the United Nations, environmental summits and scientific research prove that we are facing detrimental environmental issues. As early as Rachel Carson's *Silent Spring* (1962) and Paul Ehrlich's *The Population Bomb* (1968), we have been exposed to climate change warnings and the "unsentimental reports on issues and trends that most wish to ignore or pretend will somehow be miraculously solved by technological innovation" (Wells, 2003:268).

Despite our knowledge of environmental troubles, new buildings are proliferating even as the world's resources are at a premium. "Suburban sprawl continues to remove productive forests and agricultural lands and create a landscape that numbs the soul" (Wells, 2003:271).

"The life cycle components of the typical building – its materials, the land on which it sits, how it is designed to work with local temperature, rainfall, sun, wind, the humanity of the interior environment, the ability to adapt and change, and the preservation or re-use and recycling of the whole or the parts at the end of its functional life – are in fact controllable by the designers, builders, developers, and owners of buildings" (Wells, 2003:268).





### 3.2.1 ECOLOGICAL DESIGN AND CONSTRUCTION

The concept of ecological design and construction is based on the systems of nature. In emulation of biomimicry, the study of nature enables the reproduction of nature's 'blueprint' and applies it to architecture. "Ecosystems are the source of important lessons and models for transitioning human activities onto a sustainable path" (Kilbert, Sendzimir and Bradley Guy, 2003:6). The design process looks at a number of scales involving the holistic intension. This informs and enables a study of different linking systems that, when put together as a whole, establish closer linking and cyclical processes which enable sustainable design. "Examining nature and ecological systems for patterns of energy and materials metabolism for their potential adoption into human systems can provide a substantial improvement on current methods of attempting to green the built environment" (Kilbert et al, 2003:26). These thoughts are synonymous with Fritjof Capra's theories. He mentions that the main characteristics of 'systems thinking' emerged simultaneously in several disciplines during the first half of the 20th century. It was initially thought of by biologists who insisted that living organisms are best understood as integrated wholes (Capra, 1997:21). It was further deepened by Gestalt psychology and the new science of ecology. It affected quantum physics which showed that at the subatomic level there are no parts at all, that what we call a part is merely a pattern in an inseparable web of relationships (Capra, 1997:21).

Capra believes that the key to the theory of living systems depends on two approaches: the study of pattern (or form, order, quality) and the study of structure (or substance, matter, quantity). The structure approach tries to understand the properties that make up the object of study. The pattern approach attempts to understand the relationships between its constituent parts (Capra, 1997). The combination of these two approaches in accordance with the living systems theory brings about a new way of thought and comprehension of reality. Pattern, structure and process are inseparable perspectives of life. Thus to understand any living system one must ask these three questions: what is its structure? What is its pattern of organization? And what is the process of life? (Capra, 1997:21) These questions are relevant in design and construction; they are very important in creating a building that works as a whole.

Design should be aware and responsive to context, climate and the surroundings. "Ecological design is a design of place, the place of the users, the climate, the topography,

and the local culture. As in Nature, where species from similar genetic strains will evolve into subspecies when faced with different bioregional forces, so will the generic 'modern' architecture building either fail in its location (environmentally) or adapt" (Guy, 2003:228). As time passes, needs and conditions change. Architecture cannot afford to ignore these changes, as deterioration and disruption occur in cycles thus affecting systems of the building, the block within the city, and the city itself.

This thesis takes a stance in investigating sustainability in the built environment at different scales. It will focus on the mitigation of climate change through learning from and reacting to nature. This theoretical viewpoint provides a spine which will guide the design in a manner that works with nature so as not to destroy it. The Eastgate Centre is a precedent that uses nature's systems in a termite mound and uses the concept in the design of a large scale shopping and office block.

### 3.2.2 GREEN STAR RATING TOOL

The Green Building Council of South Africa (GBCSA) developed Green Star SA, based on the Green Building Council of Australia's Green Star rating system, to provide the commercial property industry with an objective measuring tool for green buildings and to recognize and reward environmental leadership in the property industry (GBCSA, 2008:v). Each Green Star SA rating tool reflects a different market sector or phase in the building life cycle (GBCSA, 2008:v).

The objective of the rating tool is to establish a common language and standard of measurement for green buildings and to promote integrated, whole-building design. The handbook discusses sustainable approaches that aim to reduce environmental impacts of development.

Green Star SA covers a number of categories that assess the environmental impact that relates to the sequence of a project's site selection, design and construction (GBCSA, 2008:v). This thesis will adapt the criteria according to which the rating tool measures sustainability in an office building. It will systematically provide information and strategic elements to inform the proposed design of the Agrivaal Building. Certain categories will be used to assist in focusing on environmental design i.e. ventilation, heating and cooling and natural light in a building.



Fig.219:Eastgate Shopping Centre, designed influenced by the work-ings of a termite hill. [Source: [www.treehugger.com/files/2006/08/biomimetic\\_buil\\_1.php](http://www.treehugger.com/files/2006/08/biomimetic_buil_1.php), accessed 2 October 2011]

Fig.221:Eastgate Centre elevation, with chimney vents allowing air to escape the building. [Source: [www.nubianarchitects.wordpress.com/2010/08/16/termite-and-temperature-control-from-zimbabwe/](http://www.nubianarchitects.wordpress.com/2010/08/16/termite-and-temperature-control-from-zimbabwe/), accessed 2 October 2011]

## Eastgate Centre

Harare, Zimbabwe  
Architect: Mick Pearce

precedent study on ecological design

The Eastgate Centre was designed to be naturally ventilated and cooled. The designed systems we based on termite mounds which included flues which allow for ventilation through the sides and on top of the mound. The termite mound is shaped in a manner that catches the breeze allowing it into the mound. The termites control the air flow by opening or blocking the tunnels which helps the hot air from the main chambers below the ground exit the structure (Doan, 2007).

Similarly, the Eastgate Centre draws in air which is either warmed or cooled by the building mass, depending on whether the concrete or the air is hotter (Doan, 2007). The air is vented onto concrete beams on the floors of the building's offices before leaving through chimneys at the top.

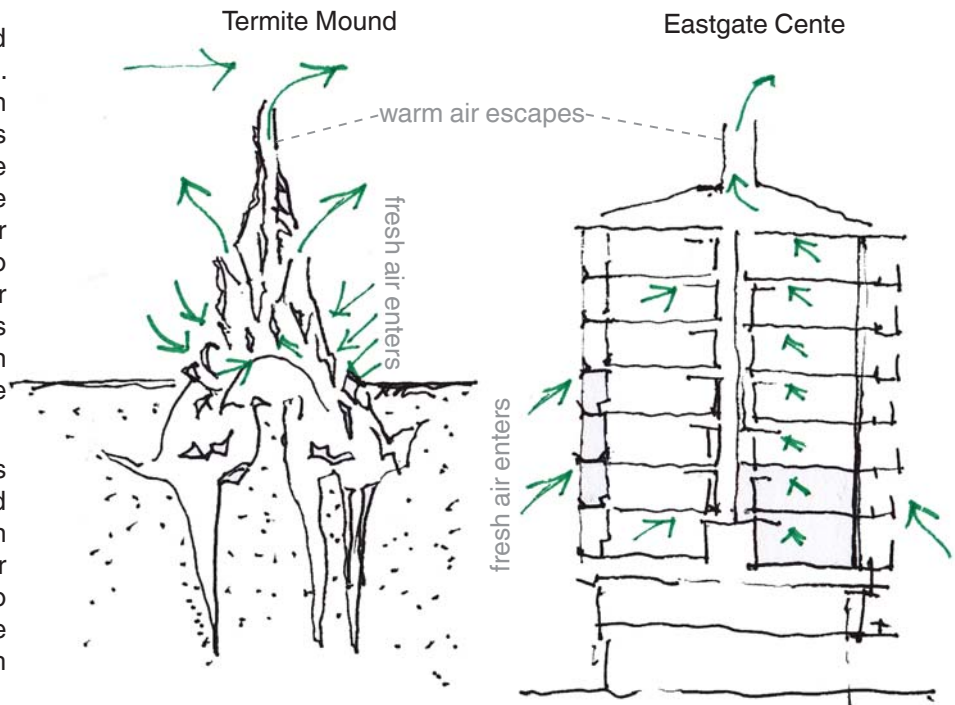

Fig.220: Ventilation [Source: [www.treehugger.com/files/2006/08/biomimetic\\_buil\\_1.php](http://www.treehugger.com/files/2006/08/biomimetic_buil_1.php), accessed 2 October 2011, edited by author 2011]

## 3.3 Heritage

### Introduction

As mentioned in chapter one, the definition of cultural significance is that of “aesthetic, historic, scientific or social value for past, present or future generations” (The Australis ICOMOS Burra Charter, 1999:1). The Agrivaal Building is considered to be part of a cultural significant layer in the City of Tshwane. This layer speaks of the architectural advancement and international influence that has left its mark in the city. This mark is part of the city’s heritage and must be respected and maintained.

Different buildings have different importance and cultural significance. The Union Building is the seat of the administrative government of South Africa. Designed by Sir Herbert Baker in 1908, the building represents layers of heritage and political, social and economic advancement in South Africa. In contrast, the Agrivaal Building may not have such high value and cultural significance on a national scale like the Union Buildings. However, it holds significance to Tshwane, showing signs of architectural transformation in the city in its era. It is a building that forms part of the approach to the Union Buildings and must be awakened from its dormant, abandoned state and contribute to its surroundings.

### Heritage strategy:

A building analysis on the Agrivaal Building (Chapter 4) will highlight elements of cultural significance that will be of importance in the intervention. This process is subjective to the author, and will be moderated by using the Burra Charter, as an international guideline on principle of conservation and cultural significance.

### Burra Charter

The aim of the Burra Charter is to conserve places of cultural significance. According to the Burra Charter the reasons for conservation are as follows :

- people’s lives are enriched
- the preservation of historical records is ensured
- connect the community and landscape, to the past and to lived experiences
- reflect the diversity of a community
- preservation for the present and future generations

The Burra Charter presents a set of guideline that assists in the comprehension of the cultural significance of a place. The following five chapters of the conservation process are pertinent to this design process:

## The Burra Charter Process

Sequence of investigations, decisions and actions

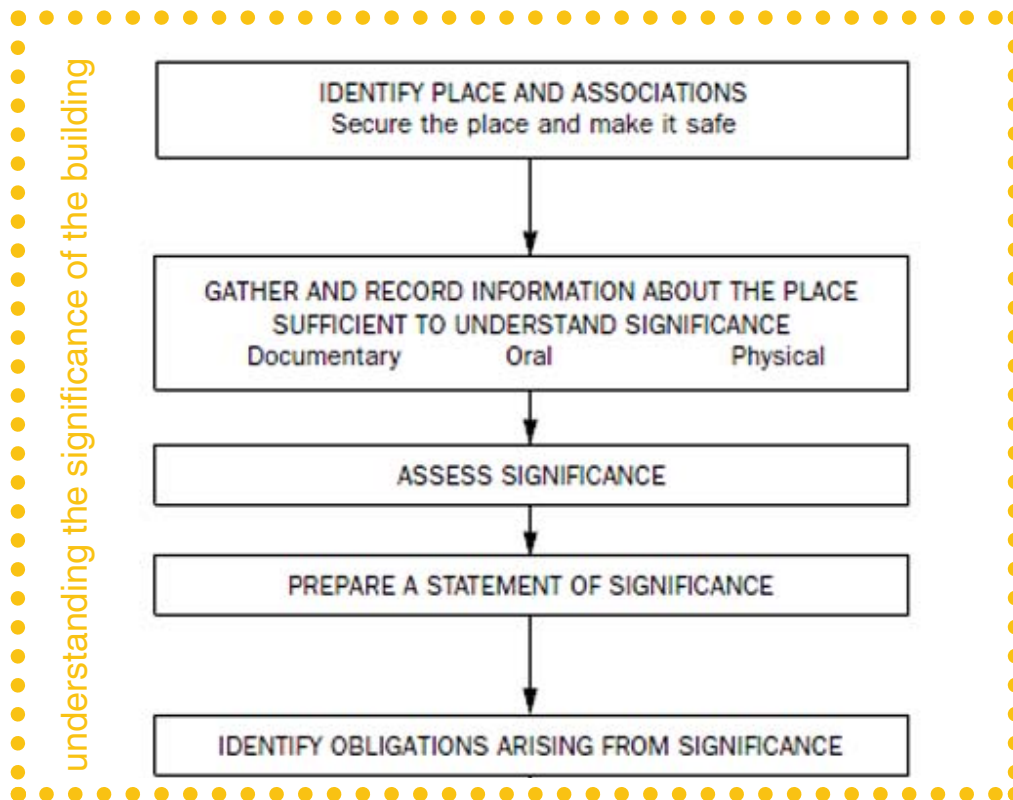

*Fig.222:Process from the Burra Charter that assists in understanding the significance of the building. This process has been done for the Agrivaal Building under chapter 4, building analysis*

### 3.4 ADAPTIVE REUSE

Adaptive re-use encompasses a large pool of thought. This chapter will elucidate adaptive re-use in terms of the Agrivaal Building and how it will be treated. One of the main focuses of this thesis is to be responsible about decisions made in terms of the environment and thus a sustainable approach will be taken. “All buildings, once handed over by the builders to the client, have three possible fates, namely to remain unchanged, to be altered or to be demolished” (Scott 2008:1) There are different thoughts on how buildings should be treated when it comes to a point where ‘something needs to happen’ with the building as whole. A responsible decision would be to work with the building and to neither demolish it nor to allow its condition to worsen. Thus the route taken will be of intervention and adaptation. The responsibility is towards the environment, where wastefulness and the loss of large amounts of material and embodied energy are unnecessary.

The energy used in the lifecycle of a building encompasses all the non-renewable energy consumed. This includes:

- Initial energy - to acquire, process, manufacture, transport building materials and construction
- Recurring energy – to maintain and repair the building
- Operating energy - to heat, cool, ventilate, and light the building
- Energy to demolish and dispose of the building.

A 1996 study by the Heritage Canada Foundation examined the total life-cycle energy use in a 4,620m<sup>2</sup> three-storey, generic office building. On average, the total embodied energy of such a building increases by 56.5% by the time it is 25 years old, 144% by the time it is 50, and by 325% by the time it is 100 (see graph). If the building is demolished, this embodied energy will have gone to waste (Heritage Canada Foundation, 1996:1).

The rehabilitation of heritage buildings conserves embodied energy. A study of the Angus Technopole Building, a Montreal factory built in the early 20th century, compared the energy costs associated with the rehabilitation and adaptive re-use of the building as a residential complex to the energy costs of demolition and the construction of a new building on the same site. It illustrated that rehabilitation required 5,169 Gigajoules (Gj) of energy, while demolition and new construction required 13,734 Gj of energy. Restoration, in other words, would require 8,565 Gj less energy than demolition and building anew (Heritage Canada Foundation, 1996:1).

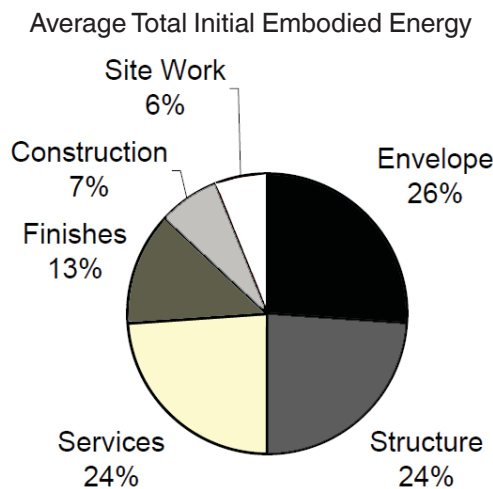

Fig.223:Pie chart showing the percentage of average total embodied energy [Source: [www.heritagefoundation.ca/docs/Energy\\_Waste\\_EN.pdf](http://www.heritagefoundation.ca/docs/Energy_Waste_EN.pdf). accessed: March 2011]

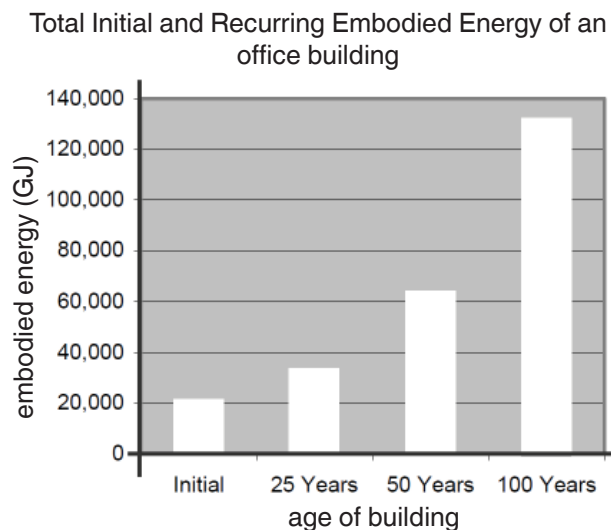

Fig.224:Bar chart showing the recurring embodied energy of an office building [Source: [www.heritagefoundation.ca/docs/Energy\\_Waste\\_EN.pdf](http://www.heritagefoundation.ca/docs/Energy_Waste_EN.pdf). accessed: March 2011]

### 3.4.1 'ALTERING ARCHITECTURE' -

#### ALTERATION, ADAPTATION, ADJUSTMENT

Alteration offers an alternative to preservation or demolition, and is a more general strategy to keep buildings that are to be inhabited/occupied extant beyond their time (Scott, 2008:11). Some buildings with heritage value are artefacts that must be preserved rather than worked with. The Agrivaal Building and its associated heritage will inform the new design, from concept to materiality. In the book *On Altering Architecture*, Fred Scott mentions that "the idea of a work of art is one that attempts to exclude alteration" (2008:7). This implies that a building is not necessarily a work of art which must be preserved and untouched, but rather that, with informed decisions on working with a heritage building, an informed judgment may encourage demolition in certain areas, or the option of creating a new complimentary addition in other areas.

"Context is inescapable for the interventionist; work is clearly inseparable from its context" (Scott, 2008:143). Intervention is almost always more complex than context and pure architecture. It is the cause of the intimacy that the designer must cultivate with the given building, and this is equally not limited to scale (Scott, 2008:143).

If a building is to be altered, chances are it will be altered again. The designer therefore carries responsibility for a building's past, its present and indirectly its future. The interventionist makes a contribution to a continuum, which is the life of the host building (Scott, 2008:143). The understanding that the city is always changing and that the needs of users are constantly modified, gives that greater and definite comprehension of how buildings will also alter towards new needs. It is thus imperative that any design will have the ability or at least the consideration of thinking for the future, but highly considering the present requirements and respect of the layered past.

"When a building is complete it wants to say, look how I'm made. But nobody is listening because the building is fulfilling function. When it becomes a ruin, the building becomes clear, the spirit returns. For Louis Khan, therefore, the spirit or essence of a building is something separated from form and perhaps in some cases antagonistic to function" (Scott, 2008:62).

The spirit of a building should not only reappear once the building is not in use or has been destroyed. This spirit must be experienced and explored by the users. It is as much part of the experience of the building as comfort and usability.

### 3.4.2 PROCEDURES IN ALTERING A BUILDING

Fred Scott provides a system for confronting an adaptive re-use project. He describes four planning procedures, 'stripping back', 'making good', 'enabling works' and 'new works.' These procedures will be used in addressing the new intervention for the Agrivaal Building and will thus guide the design in terms of heritage and sustainability.

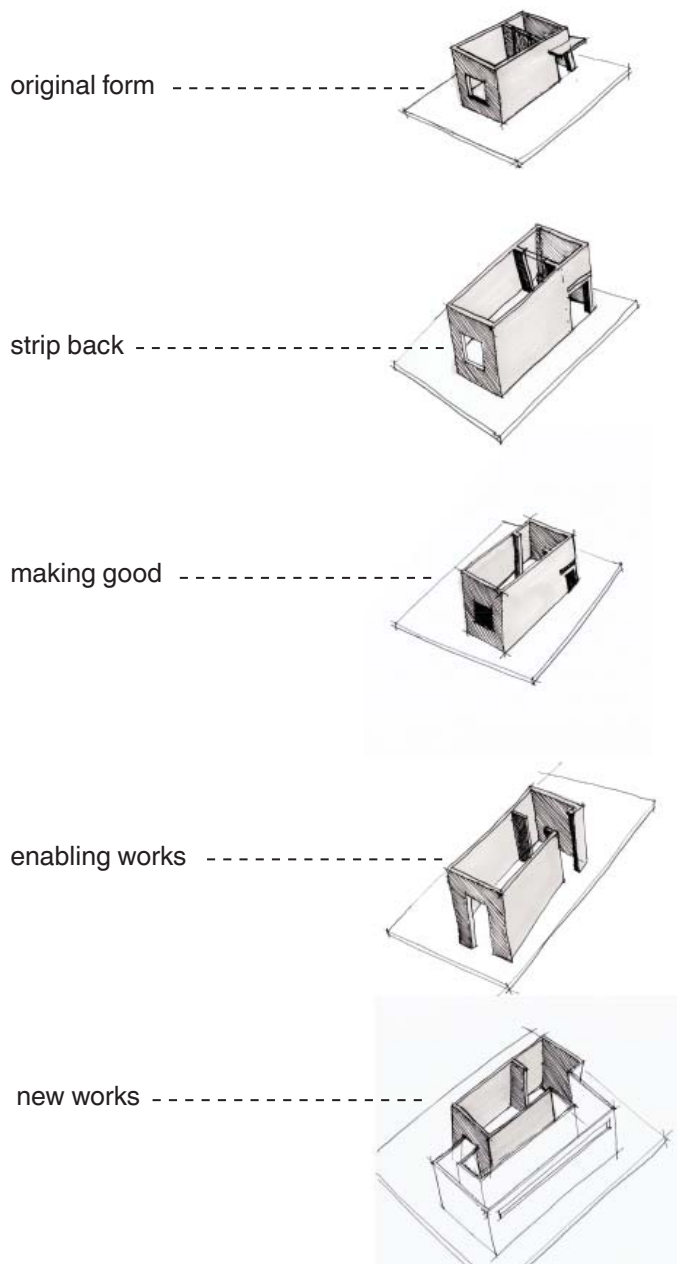

Fig.225: Interpretation of Fred Scott's theory on altering architecture [Source: author 2011]

### 3.5 CURRENT STANCE AND APPLICATION

Groák mentions that “everything we create has at least two narratives through which we comprehend it, two reasons for existence – ‘reason’ as purpose or ‘reason’ as cause” (1993:38). Reason as purpose refers to how we understand purpose, the aesthetic, functional, economic etc. Reason as cause refers to the social and economic circumstances which materialised the building (Groák, 1993). ‘Purpose’ and ‘cause’ are guiding principles in the new intervention on the Agrivaal Building. Consideration for and comprehension of what the previous intentions of the building were will guide current decisions. However, environmental concerns will have to be included in the responses, as they are part of issues that the world is currently experiencing. A significant problem concerning the globe cannot be ignored.

The inhabitants of the planet demand a constantly rising amount of non-renewable resources, with very little control over or consciousness of the impacts relating to current and future generations. An age where disposable non-recyclable products are the norm, and ‘brand new things’ are wanted and not needed, contributes to the environmental crisis.

The thoughts of the average world citizen need to be concerned with recycling, re-using, conserving and harvesting – with a more sustainable way of living. The media, non-governmental organizations, and many governments are slowly encouraging this phenomenon, while many contradictions occur at the same time.

Architecture and the built environment must be part of this sensitization of ignorance towards the environment. A large percentage of material resources taken from nature are building related.

The building sector contributes a large percentage to national waste levels, as well as to the amount of energy consumed.

This thesis aims to specifically investigate an existing building that does not necessarily function well in terms of sustainability, due to the era in which it was built. It is a building that has been deteriorating for a number of years and thus any alteration done to it must be appropriate and should respond to the current needs of the environment. The intervention should respect the building in terms of its architecture, construction and aspects of cultural heritage. It will utilize systems of self sufficiency and interior environmental comfort (bio-climatic comfort). A system that is built with nature, responding to nature and respecting nature, will be created.

The built environment’s moral stance must evolve in terms of understanding the short and long-term repercussions of design decisions. It is therefore imperative that sustainability be an essential informant in design. This thesis intends to be an example of consciousness of the environment, working with existing buildings and thinking contextually.

The Agrivaal Building acts as a ‘shell’ in which sustainable design decisions will enable the success of the building in terms of user comfort, respect for context and cultural heritage. There are a number of tools that ‘measure’ the sustainability of a building. These tools are divided into categories and thus determine how successful the building is. These categories will specifically be investigated and where applicable be incorporated in the design for the Agrivaal Building.

#### 3.5.1 QUESTIONS ANSWERED?

The questions discussed refer to the introduction of the theory chapter, where climate change and architecture preceded theory on ‘sustainability’ and ‘alteration’.

What is the role of architecture in an era of climate change? Can architecture really influence the world in its current environmental state?

In terms of the theory discussed, these questions have been posed and postulated. Hypothetical answers may perchance be provided within a decade or century, depending on the proactive efforts of the current generation.

The author’s hypothesis: The role of architecture is to respond to need and context. Context includes the actual site and its conditions concerning solar angles, wind direction, vegetation etc. It includes the influences of the city block in which the site is located, the precinct, the city, the country, the continent, and finally the earth as a whole. These different scales will all be affected in numerous ways and in different timelines. These affected scales will require different reactions and create different concerns. In this century, at the largest scale and amongst other societal issues, the earth is concerned with global warming and its repercussions affecting all scales of life.

Comprehension of the different scales of context, their interdependency and associated connections will bring answers concerning the mitigation of climate change through the built environment.

Context has changed. Architecture must respond to context.

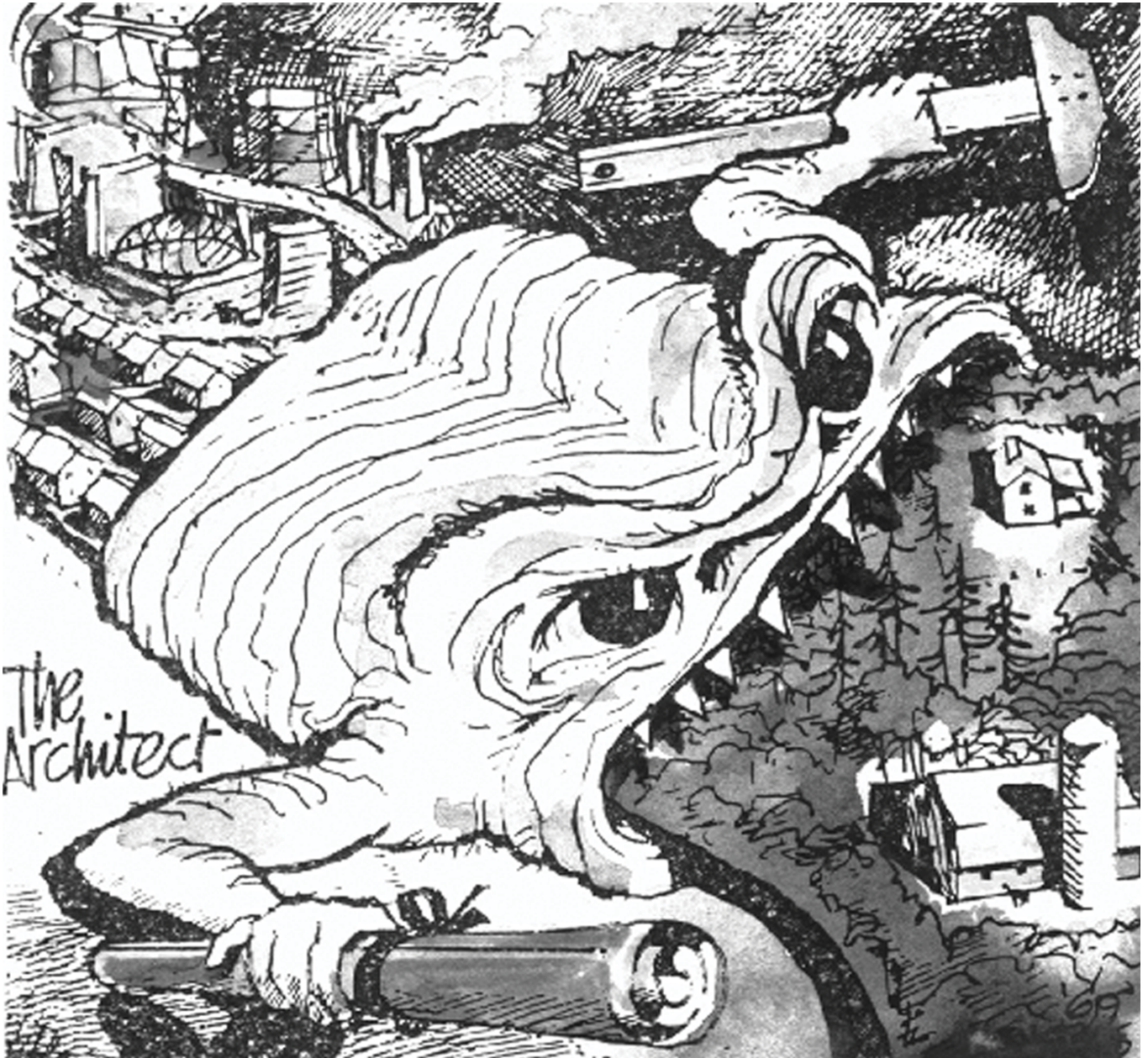

Fig.226:A image portraying the architect as a major cause in changes in the environment. [Source: WELLS, p 272]



# chapter 04

## context

---



Fig.227:the world

# 4.1\_context

## 4.1.1\_INTRODUCTION

This chapter is divided into three parts. The first part will discuss the location of the project. It further describes the climatic conditions of the City of Tshwane and the legislative context of the site. The framework that the design project will be responding to is also included.

The second part will discuss the analysis of the site and its surrounding, followed by an analysis of the existing building.

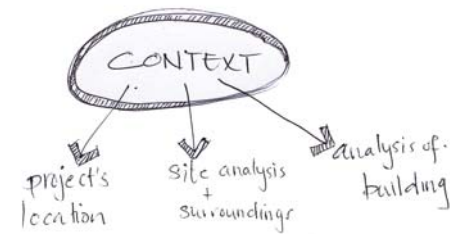

## 4.1.2\_LOCATION

Geographically South Africa is geographically located on the southern point of Africa. This project will focus in the administrative capital, Pretoria, where the European Commission is based. According to the SA-EU Development Partners Progress Report, South Africa is recognized as a major political and economic power on the African continent (SA-EU Progress Report, 2010:2), playing an important leadership role in the progress of this continent.

south africa



Fig.229:South Africa [Source: City of Tshwane Municipality, edited by author 2011]

gauteng



Fig.230:gauteng [Source: City of Tshwane Municipality, edited by author 2011]

city of tshwane

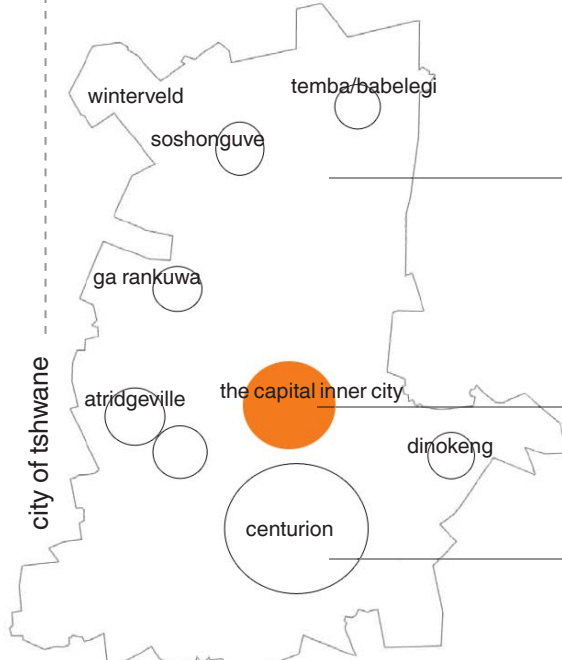

develop the North

develop urban areas

celebrate the City Core

maintain established areas

Fig.228:Tshwane framework-intensions [Source: City of Tshwane Municipality, edited by author 2011]

## 4.1.3\_CLIMATIC ZONE

### \_wind

The City of Tshwane is protected by the ridges of the Magaliesberg, Skanskop, Daspoortridge and Klapperkop. Gale winds are minimal, and the general direction of wind in summer is in a north-easterly direction, blowing in winter from the north-west.

Design implication:

To solely utilise wind as energy will prove to be difficult; however, the idea of roof cowls with the assistance of mechanical pumps can be explored to assist in ventilation, as well as heating and cooling in the Agrivaal Building.

### \_temperature and rainfall

The City of Tshwane can be classified as moderately dry subtropical, with hot and rainy summers and cool, dry winters. The average annual temperature is 18.7°C. Thunderstorms are common in summer, with levels of 110mm of rainfall recorded in the month of January. The high average rainfall presents a design opportunity in terms of water harvesting and protection from heavy rain.

Design implication:

Due to the large variations in temperature and seasons, walls and floors should provide thermal mass. External spaces should provide shade in the summer, and surfaces should be light in colour or reflective to minimize solar heat gain in the warm months (Holm, 1998:69).

The existing concrete roofs on the Agrivaal building, will collect rainfall during rainy seasons, this will be beneficial to areas of the roof that will have a roof garden. The run-off will be directed into a reservoir, where treatment and use for landscaping will benefit the complex.

### \_solar

South Africa has one of the highest solar radiation levels in the world (ranging from around 1450 kWh/m<sup>2</sup> to about 1950 kWh/m<sup>2</sup> per year, compared to Europe which on average receives 910kWh/m<sup>2</sup> per year).

Design implication:

The production of energy will depend on the size and type of photovoltaic (PV) panel used, as well as where it is placed. This provides an opportunity to explore solar energy in an attempt to minimize complete reliance on the national grid.



Fig.232:Wind driven ventilation system in Sutton, England. Wind cowls use the wind to draw warm stale air up from inside, and direct fresh air downwards over passive heat exchanger [Source: [www.flickr.com/photos/8586443@N03/2377282168/in/photostream/](http://www.flickr.com/photos/8586443@N03/2377282168/in/photostream/)]

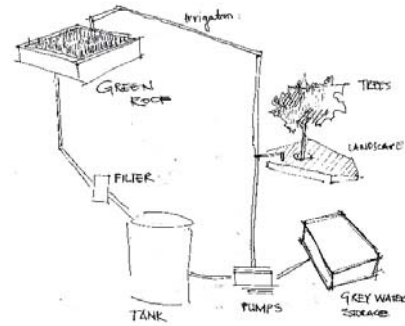

Fig.233:concept sketch of recycled water system from green roof [Source: Author]

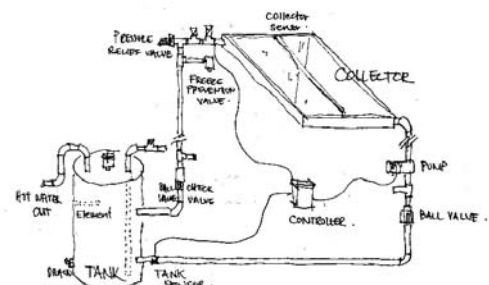

Fig.231:solar water heaters utilizing solar energy to provide warm water [Source: [www.solardev.com/FSEC-solar-heating.php](http://www.solardev.com/FSEC-solar-heating.php), edited by author 2011]

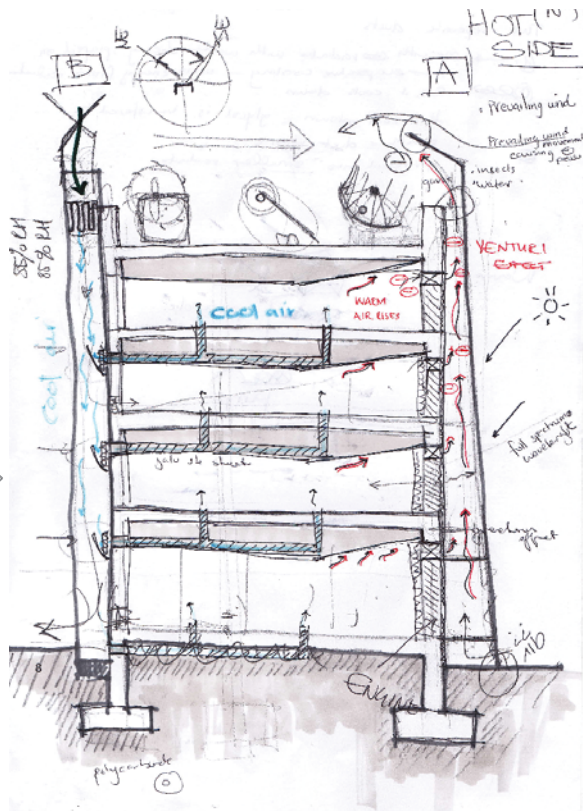

Fig.235:concept of proposed ventilation in the Agrivaal Building [Source: Author]

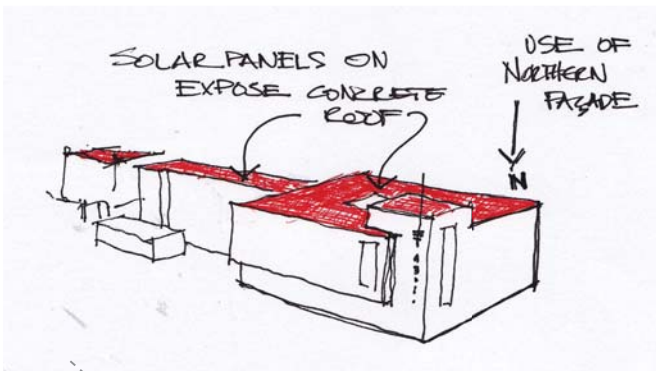

Fig.234:large roof space where areas will be for PV panels [Source: Author]

## 4.1.4\_SITE LOCATION



Fig.236:Position of the Agrivaal Building Source: City of Tshwane Municipality, edited by author 2011]



Fig.237: The Agrivaal Building, located on the corner of Hamilton Street and Edmond Street. [author:2011]



UNIVERSITEIT VAN PRETORIA  
UNIVERSITY OF PRETORIA  
YUNIBESITHI YA PRETORIA

HAMILTON STREET



EDMOND STREET





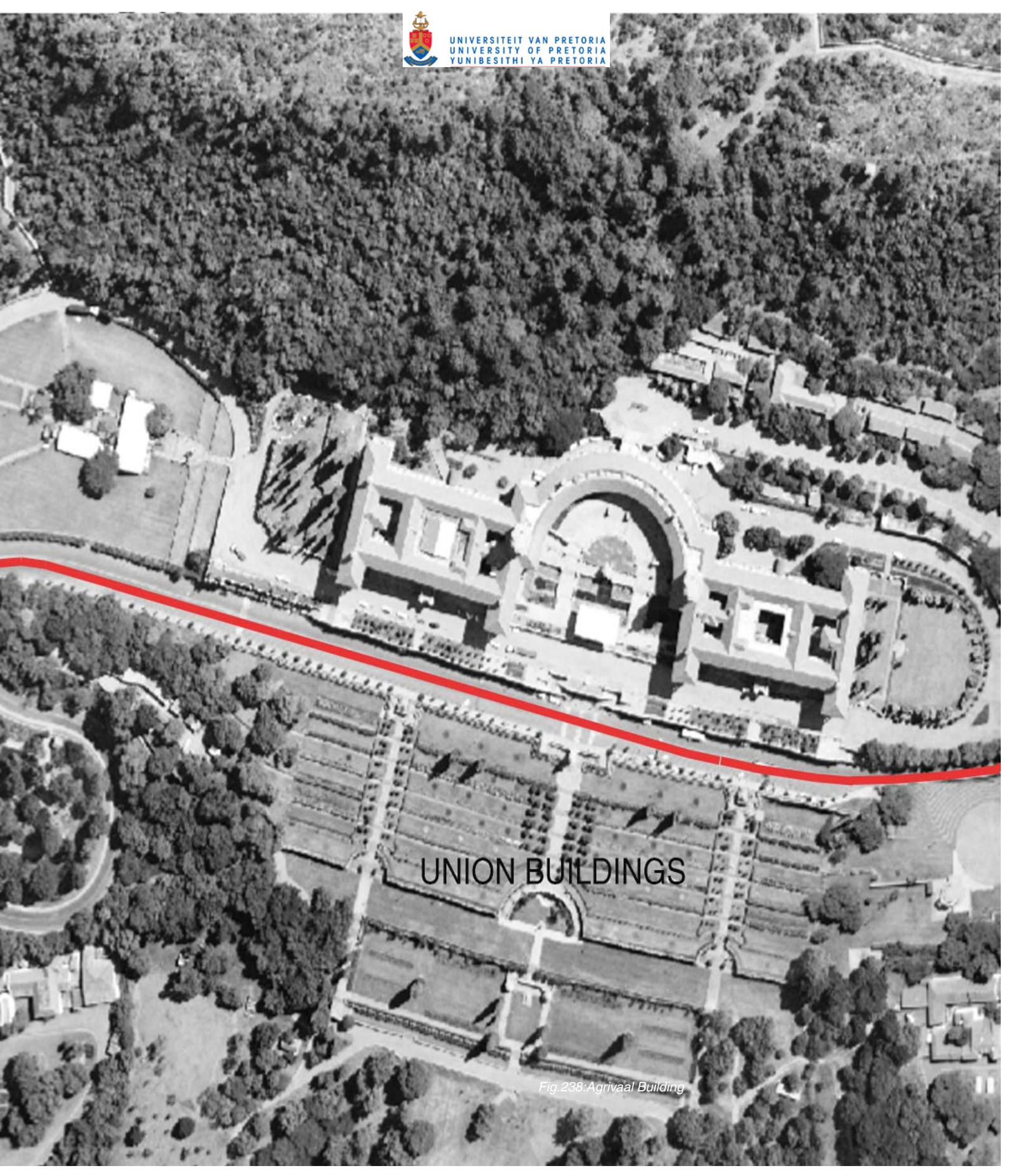

UNION BUILDINGS

Fig.238: Agrivaal Building





## 4.1.5 LEGISLATIVE CONTEXT

The following site information has been gathered from the Municipality of the City of Tshwane.

**Erf number:** 1087, Arcadia

### **Zoning:**

Erf 1087 was previously zoned as 'Residential 4 - which allowed for flats, hotels or guest houses. The erf was rezoned as special when the Agrivaal Building was built as 'Special', allowing government buildings and/or offices.

### **Height restriction:**

48m

Erf 1087 falls outside the 1381m contour height restriction area around the Union Buildings as stipulated by the Tshwane Town Planning (Clarke, 2009:34).

If the proposed design would need relaxation of the height restriction, it will not have negative effects on views to or from the Union Buildings.

## 4.1.6\_URBAN DESIGN

### 4.6.1 INTERNODAL FRAMEWORK

According to the ReKgabisa Tshwane Framework that is currently being implemented in the city, three major nodal points are focused on, the Union Buildings, Freedom Park and Church Square. The area encompassed by these points are where the future interventions are proposed. These interventions are mainly located in the north-eastern quadrant of the City of Tshwane.

The intension of the framework is to explore development flexibility, thus ensuring structures that can respond to changing markets and development requirements. It thus focuses on Fred Scott's theory on 'altering architecture', however taking an urban stance and applying it to the framework. Fred Scott considers four guiding principles when making design decisions.

The main aim of this framework is to ensure that buildings respond to context and users. Furthermore, it aims to address issues of accessibility, legibility and connectivity of all buildings and streets. A guiding principle in the framework design is the focus on movement routes throughout the area, regarding these movement routes as links, a guiding tool, and an accessibility medium from

one area/building/node to another.

This framework focuses major nodes in the north-eastern quadrant of the City of Tshwane. These nodes include the Transportation Hub, the Gateway Node and the Destination Node. The links between these nodes are major movement routes within the area, as well as feeder routes to other places in the city, including the CBD.

As this area is located just outside the CBD it is noticeable that it contains few dense high-rise buildings, but consists more of 3-5 storey buildings, with the single storey building quite common. However, as the area is still in close proximity to the city centre, residential and commercial activities are still prevalent.

The intension of the framework is to explore development flexibility, thus ensuring structures that can respond to changing markets and development requirements.



Fig.239:Focus area for framework



**Internodal strategy**

Due to the scattered layout of the three sites investigated. It is proposed that three nodes are strategically identified. These three nodes will specifically indicate access into and through the proposed study area. The transportation routes within this context define the urban landscape. The connection between these access routes have been identified as nodes and were defined as:

- Gateways
- Places of Arrival or departure
- Transport hub

**Transportation Hub**

The study is located on the urban edge, north east of Pretoria's Central Business District and forms a transport node at a large intersection, where Boom, Southpansberg, Dr. Savage and du Toit Street intersect. Relation to site

The Dr. Savage Taxi Rank as well as the Blood Street Taxi Rank create high accessibility to the site, and encourage heavy pedestrian movement in this area. The Children's Development Centre and Day Clinic will be located at the centre of this transport node in order to improve accessibility and strengthen the educational and health identity of the precinct.

**SWOT Analysis**

**STRENGTHS**

- Existing Dr. Savage Taxi Rank and Blood Street Taxi Rank as transport nodes
- Many buildings with high heritage value
- Heavy pedestrian movement

**WEAKNESSES**

- Deteriorated building fabric of structures in area
- Light industrial programmes of buildings in the CBD

**OPPORTUNITIES**

- The urban edge of the city has the opportunity to become a gateway site through transport nodes
- To strengthen the existing Nelson Mandela Corridor and Apies River Framework
- Abandoned spaces to become public green spaces

**THREATS**

- The lack of educational and health identity of precinct
- Safety in the area is a problem
- The lack of a sense of ownership of buildings south of Boom Street

**Gateway Node**

Gateway node providing access to the north of Pretoria Link to proposed site: a human anatomy centre will benefit from being placed close to a high traffic area; a gateway will provide this opportunity. This is aimed at creating public awareness.

**SWOT Analysis**

**Strengths:**

- High Vehicular/pedestrian traffic levels
- Relationship of node to other institutional buildings
- Access point to the north of the city

**Weakness:**

- The current opportunity for the gateway is not expressed
- Deteriorated building fabric
- Area has light industrial properties. This reduces the opportunity for the user to interact with the urban environment.

**Opportunity:**

- Introducing a gateway provide the opportunity for public interface
- There is now the possibility of introducing a new urban destination
- Placing an anatomy centre in this context should provide growth from within contrasting superimposition.

**Threats:**

- The underutilization of the current Tshwane district hospital site, in conjunction with the perceived poor service delivery is a major concern

**Destination Node**

The Union Buildings, The Seat of Parliament, touristic destination and recreational site.

The Agrivall Building is located on Edmond Street, which leads the Union Buildings. It is one of the last buildings approaching the 'destination' and thus provides a 'gateway' into or out of the site.

**SWOT Analysis**

**Strength**

- The 'node' is located close on BRT and taxi routes
- Hamilton Street is a busy street and allows for traffic flow into the site
- The 'node' is located on the Rekgabisa Framework as part of the Government Boulevard which enriches the identity of the city.
- Framing of the street by heritage Pine Trees from the Union Buildings, relates to the identity of the area

**Weakness**

- Not many pedestrians
- Residents in the area do not use the quieter streets
- Feels unsafe
- No proper signage towards the Union Buildings
- No street furniture

**Opportunity**

- The buildings in the area can take opportunity of the visitors to the Union Buildings, by providing retail, eating places
- Regeneration of certain buildings

**Threats**

- Certain buildings are derelict in the area, not contributing to the urban fabric
- Buildings are closed off to the streets.

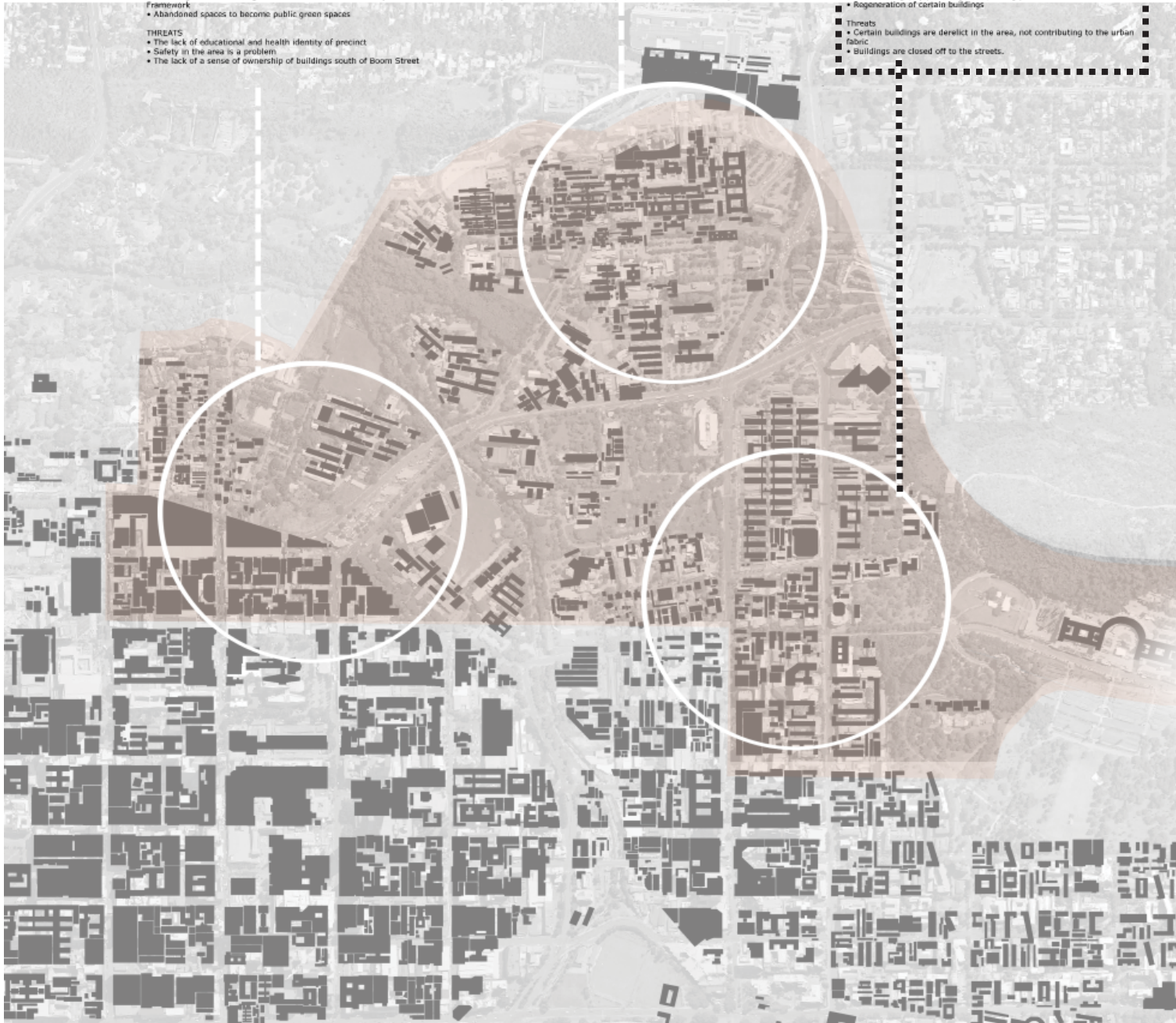



●●●●● main access routes to Agrivaal Building    ●●●●● transport feeder route    — major movement spine

Fig.240: Transport route [Source: author 2011]

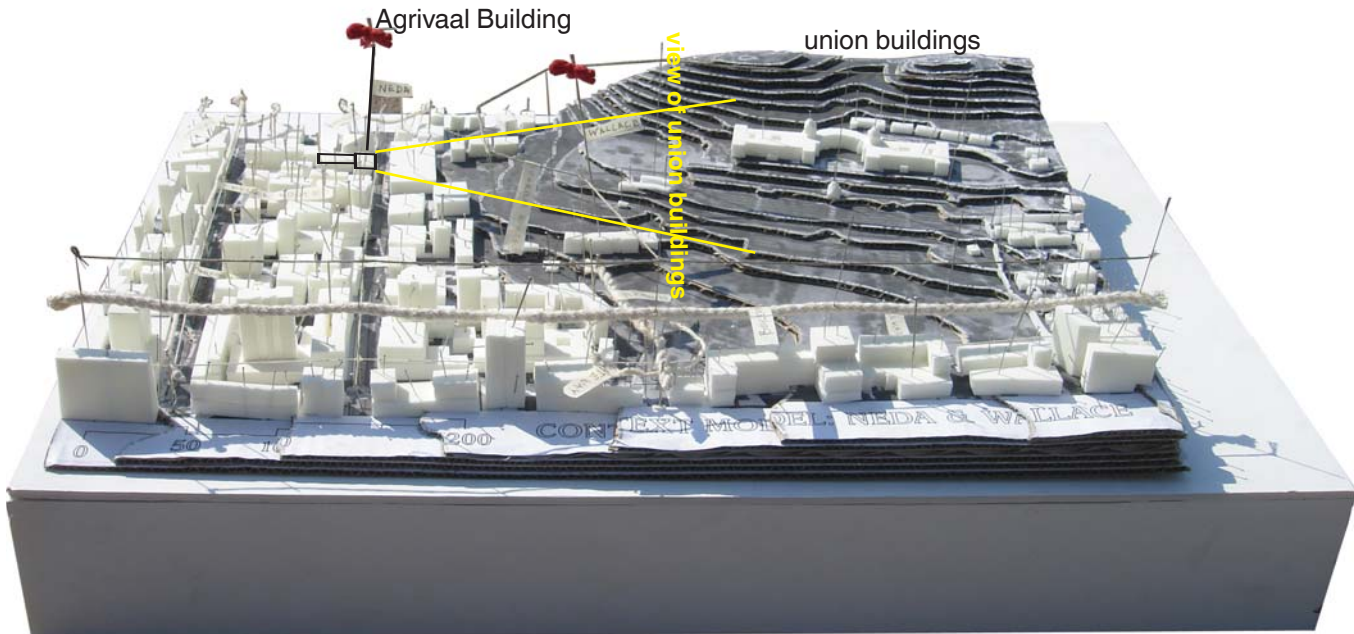

Fig.241: View [Source: author 2011]

# site analysis

---

# 4.2\_site analysis

## 4.2.1\_INTRODUCTION:

This chapter will investigate the following concepts in terms of the Agrivaal Building and its location:

- The existing site conditions and analysis thereof;
- The Agrivaal Building as a dormant building, a disregarded, abandoned space;
- The regeneration of the Agrivaal Building through adaptive re-use, and its response to existing movement patterns, surrounding iconic buildings and structures, and social interactions taking place in the area.



Fig.242:Facades of the Agrivaal Building [Source: author 2011]



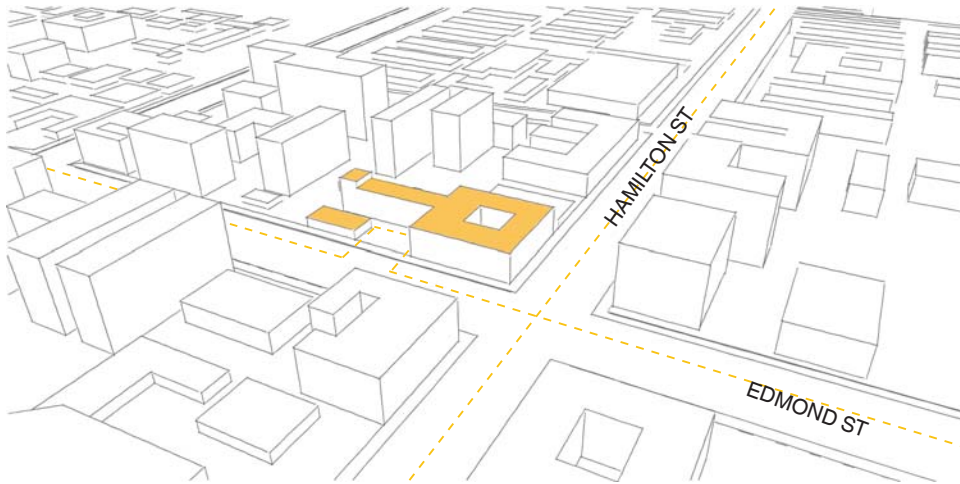

Fig.243: Massing of the Agrivaal Building and the surrounding Buildings

Fig.244: Pedestrian and vehicular movement surrounding the Agrivaal Building

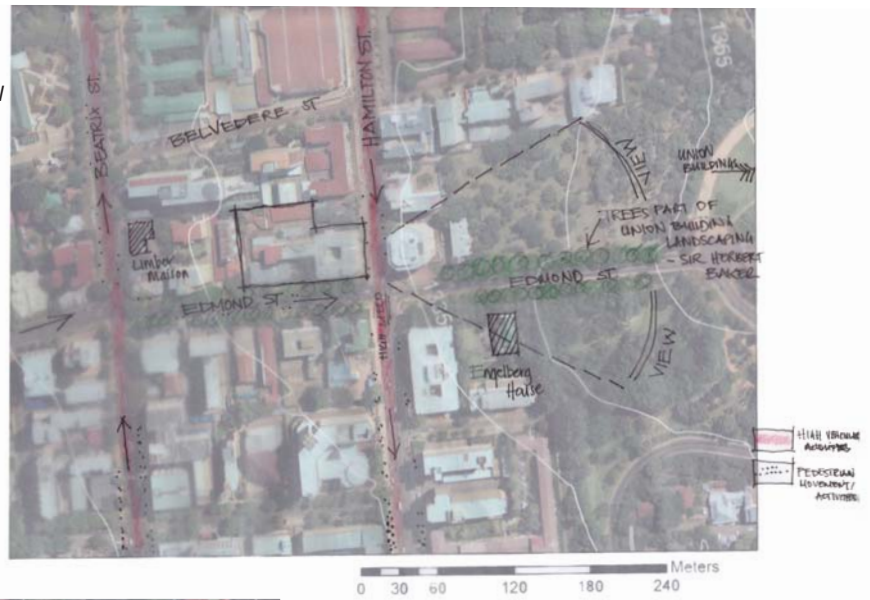

Fig.245: Height of buildings surrounding the Agrivaal Building



Fig.246: Bollards on sidewalks, however ending just before the Agrivaal Building [Source: author 2011]



Fig.247: Hamilton Street has four lanes, not very pedestrian friendly. [Source: author 2011]

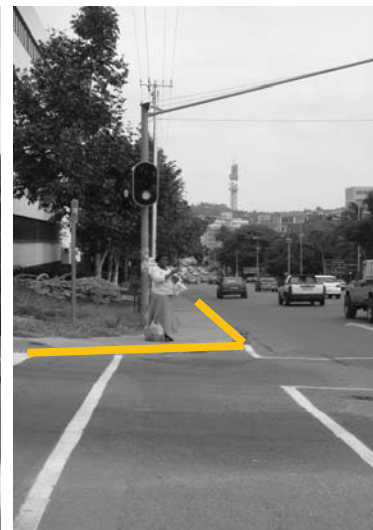

Fig.248: Narrow sidewalks [Source: author 2011]



Fig.249: High volumes of traffic at peak hours on Hamilton Street, photo taken on roof of the Agrivaal Building. [Source: author 2011]



Fig.250: Pine trees of heritage value on Edmond Street, Agrivaal Building located to the right of the photo. [Source: author 2011]

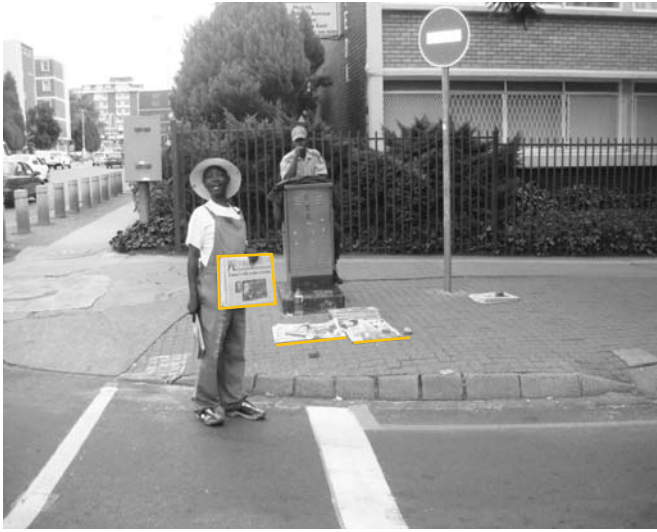

author

Fig.251:Corner of Edmond and Hamilton Street, newspaper selling, proving high movement of customers. [Source: author 2011]



Fig.252:Lack of parking on Hamilton Street, opposite the Agrivaal Building [Source: author 2011]



Fig.253:Hamilton Street, one way four lanes towards Sunnyside. [Source: author 2011]



Fig.254:Commercial activity south of the Agrivaal Building, two blocks away. The Agrivaal Building has no commercial activity in its surrounding. [Source: author 2011]

# building analysis

---

# 4.3\_building analysis

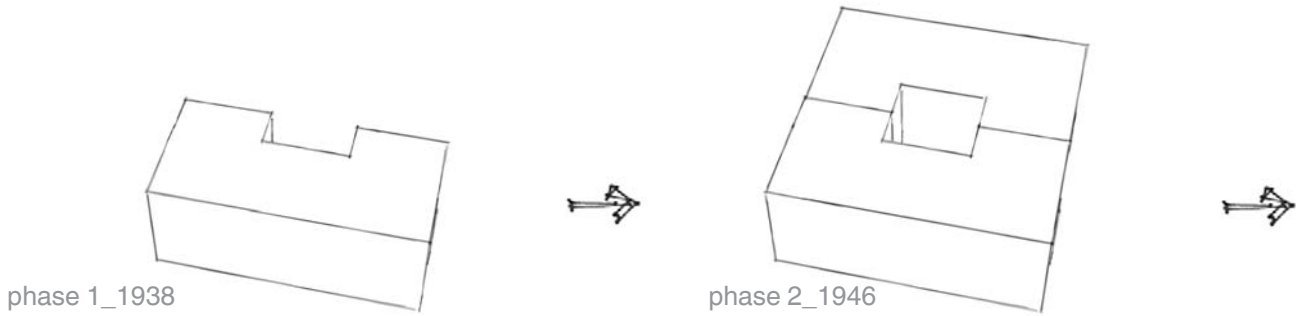

Fig.255: Building progression of the Agrivaal Building from 1938 to 1963 [Source: author 2011]

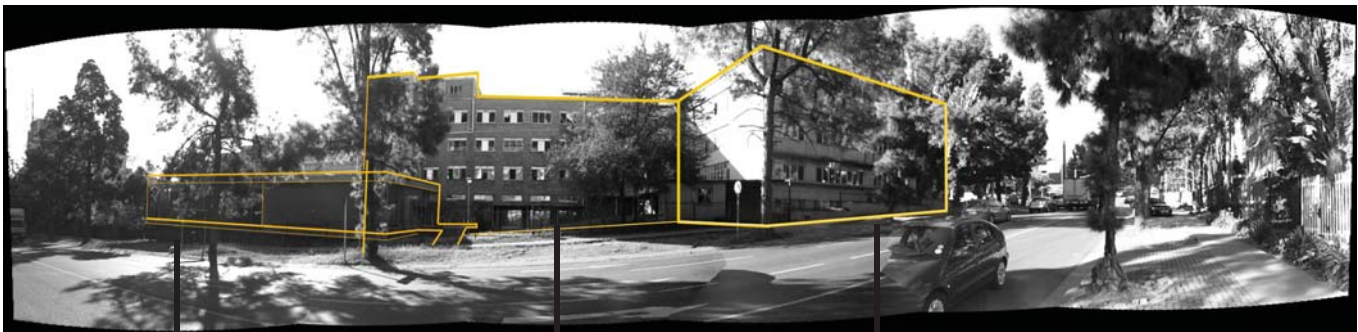
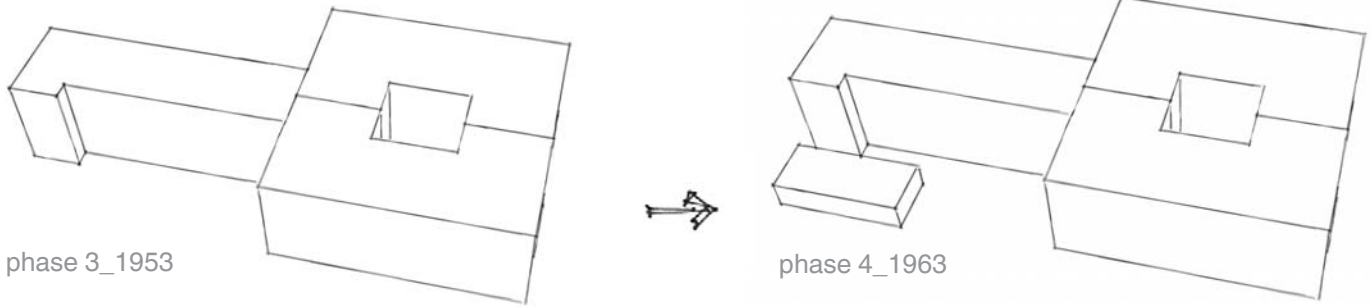

Fig.256: Clear distinction of different phases of the Agrivaal building due to material use. [Source: author 2011]



**PHASE 1 1938**  
 terrazzo clad building  
 steel casement windows  
 glass block  
 terrazzo clad planters  
 high priority HERITAGE

**PHASE 2 1946**  
 1946 addition to match east existing facade  
 north brick facade  
 accessible concrete roof  
 medium priority HERITAGE

**PHASE 3 1953**  
 low priority HERITAGE

**PHASE 4 1963**  
 high priority HERITAGE

corner articulation in an art deco manner located on the corner of Hamilton Street and Edmond Street

service courtyard

brick facade  
 steel casement windows  
 pine trees part of union buildings framework

brick facades  
 brise soleil

Fig.257: Different phases of the Agrivaal Building [Source: author 2011]

### 4.3.1 AGRIVAAL BUILDING PHASE 1 [1938]

The first phase of the Agrivaal Building is typical of the Art Deco period. The terrazzo-clad building shows evidence of early Modernism in South Africa, of which Jimmy Burg the architect of the Agrivaal Building and founder of the firm Burg Lodge and Burg, was a leading exponent. The massing and corner elements are characteristic to its stylistic era.

The visual vocabulary of Art Deco, which was used for decorative, fashionable and commercial use, included influences from Cubism, Futurism, Expressionism and other modern movements (Victoria and Albert Museum, 2011). These were used stylistically in an eclectic manner, ranging between tradition and the avant-garde. In Architecture, Art Deco mediated between the Beaux-Art tradition and modern construction techniques in its distinction between skeleton and cladding (Victoria and Albert Museum, 2011).

The Agrivaal Building uses modern construction techniques consisting of a reinforced concrete framework with brick infill. The first two phases show the need to

decorate, although in a very minimalistic modern fashion, by means of the terrazzo cladding on the street front.

The first phase, built in a U-shaped plan around an open courtyard to the north, consists of a 3 storey building with steel casement windows. The main feature of the simple façade is the corner entrance which is celebrated with a Cubist protrusion defined by glass block elements and a flag mast (refer to fig 2). The main entrance is defined by a freestanding round column. The original doorway has been stolen and currently the entrance is partially closed in with rough brickwork (Clarke, 2009).

Windows are placed almost flush on the façade, relating to the Modernist Movement (Clarke, 2009). The whole of the street façade is covered in terrazzo panelling, which is presented in square blocks, emphasizing the modular nature of the building through this expression on the façade.

The whole building is crowned with a tubular steel balustrade along the parapet wall, typical of Modernist buildings of this era (Clarke, 2009). The facades are plain plastered brick with steel casement windows. They are interrupted by cast iron plumbing accents where needed.

The design of sidewalk elements is in the language of the building, incorporating stairs, planters and platforms for planting in pots, all of the same beige terrazzo. Disabled access was limited, and thus the resulting unsightly concrete ramps for wheelchair access are not in keeping with the overall design of the building (Clarke, 2009).



Fig.258: Corner articulation of the Agrivaal Building [Source: author 2011]



Fig.261:Phase 1 of the Agrivaal Building [Source: author 2011]



Fig.259:Phase 2 addition of the Agrivaal Building, 1946. [Source: author 2011]

### 4.3.2 AGRIVAAL BUILDING PHASE 2 [1946]

The second phase followed the same aesthetic as the first phase of the building, completing the courtyard and providing the building with (now enclosed) balconies on the Hamilton Street façade. This second phase completed the building as a courtyard building, however the façade that do not face the road is not clad in terrazzo (north and west façade).

### 4.3.3 AGRIVAAL BUILDING PHASE 3 [1953]

This addition presents face brick facades, possibly to avoid the high cost of covering the façade in terrazzo. It is set back from the street, connecting on the western façade of the main building. This section of the building follows the bare functionalist aesthetic of the courtyard of the Phase 1 and 2 Agrivaal Building, with some exceptions. The same proportioning as that of the original building was used in terms of the steel casement windows. The building, mostly roofed over with a flat concrete roof also has a balustrade at a higher level, providing for safety to the accessible roof (Clarke, 2009). The building is terminated at the western end by a hipped corrugated-iron roof. At the far western end a single storey corrugated-iron hipped roof provides for open parking at ground level (Clarke, 2009).



Fig.260:Phase 3 addition of the Agrivaal Building, 1953. [Source: author 2011]



#### 4.3.4 AGRIVAAL BUILDING PHASE 4 [1963] COUNCIL CHAMBER

The Council Chamber can be categorised under the 'Brazil Builds' movement of the 1960s that was imported to Pretoria. As is typical of this movement, a range of materials is utilised in the building. Typical elements include rough stone walls, floating terrazzo stairs, mosaics and terracotta airbricks used as screening elements.

This single storey building (plus semi-basement to the west), placed between the street and the third phase 1953 building, defines the street boundary on Edmond Street towards the lower reaches of the site. Its placement creates a semi-enclosed space off Edmond Street, but this has little value as it is defined on one side by the vehicular entrance to the complex and bears no relation to the main entrance on the corner of Edmond and Hamilton Streets (Clarke, 2009).

The building is roughly square on plan with thin steel piloti enclosing a circular council Chamber, expressed as a separate element and celebrated through the oval shape of the Council Chamber itself punching through the concrete roof.

The façade of the building, defined above and below by strong horizontal terrazzo bands (reminiscent of the main building) bears little relation to the rest of the complex, being of a rough dark face brick in soldier bond without any openings along the sides but providing for daylighting towards the west (Clarke, 2009). The entrance to the building is from the east, accessed by pre-cast terrazzo steps floating on a steel substructure.

The building was entered through plate glass doors, now badly vandalized, over a marble and granite floor into a green mosaic entrance foyer, over a kidney-shaped water feature/fish pond which is now derelict.

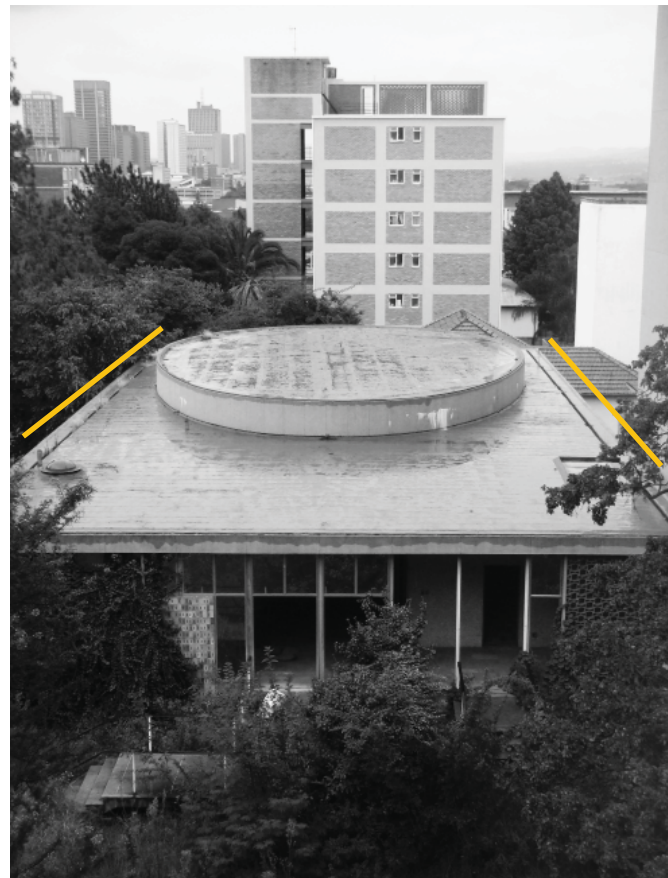

Fig.262:Phase 4 addition to the Agrivaal Building, 1963 Council Chamber. [Source: author 2011]

### 4.3.5 ANALYSIS OF SPECIAL ARCHITECTURAL ELEMENTS OF CULTURAL SIGNIFICANCE

This section will deal with specific identified elements of value, i.e. those aspects of the building most worthy of conservation. It will highlight elements worthy of retention as well as those not so worthy, in order to feed into the decision-making process of the architect. This section has been compiled by means of site visits with a professional architect with experience in heritage, as well as reference with existing analysis documents.

Not all elements will be dealt with in this section. Only elements that have been altered or are relevant to the proposed design will be discussed.

#### **AGRIVAAL PHASE 1 BUILDING (1938) and AGRIVAAL PHASE 2 BUILDING (1946)**

##### **Main Entrance**

The sequence of stairs, planters and platforms leading to the main entrance of the Agrivaal building should be restored, all later accretions (crude access ramps and palisade fence) removed. A new door, of contemporary design, but with sympathetic proportioning to the character of the original design, should be installed. Due to its proximity to the main staircase, this new door could be designed to be utilized as emergency exit.

##### **Glass block panels**

These will be retained and repaired where possible. Glass block panels showing some of the damage that has occurred over time.

##### **Exterior planters**

The design of sidewalk elements is particularly striking, incorporating stairs and planters and platforms for planting in pots all of the same beige terrazzo.

##### **Concrete roof**

The building, mostly roofed over with a flat concrete roof also has a balustrade at a higher level, providing for safety to the accessible roof.



*Fig.263: Glass blocks used to accentuate the corner articulation of the Agrivaal Building [Source: author 2011]*



*Fig.264: Main existing entrance, currently blocked by a brick wall. [Source: author 2011]*

## Mast

The corner mast will be retained as a vital element in the appearance of the building and as contributing factor to the landmark character of the corner of this building on the streetscape (Clarke, 2009).

## Façade Lettering

Like the mast, the lettering should be retained as an integral part of the character and original use of the building.

## Terrazzo Cladding

The whole of the street façade is covered in terrazzo paneling, jointed to form square blocks, emphasizing the modular nature of the building through this expression on the façade. The whole is crowned with a tubular steel balustrade along the parapet wall, typical of Modernist buildings of this era (Clarke, 2009).

## Mural

Commissioned for the entrance foyer of the Maize Board building, this mural, dealing with the cultivation of the mealie, is of value only in situ, in the space it was designed for. While some of the scenes may be thematically offensive to contemporary society, its value lies exactly in its recording of the mindset of a particular class at a particular time in the history of South Africa. It should not be removed. The artistic merit of the work however does not preclude its adaptation. It is proposed that an artist be appointed to add a layer to the mural, thereby making it current. This accretion should be reversible, easily movable or hinged. It should not damage the fabric of the mural in any way, but it can serve to cover some of the more offensive scenes of servitude depicted in the mural. This layer should be in dialogue with the original and form, with the original, a new artwork with new interpretations, not completely obscuring the original artwork.(Clarke, 2009).

## Windows

It is envisioned that the existing windows of the original building might not meet the safety and environmental



Fig.265:Lettering and the teak mask. [Source: author 2011]



Fig.266:Mural. [Source: author 2011]

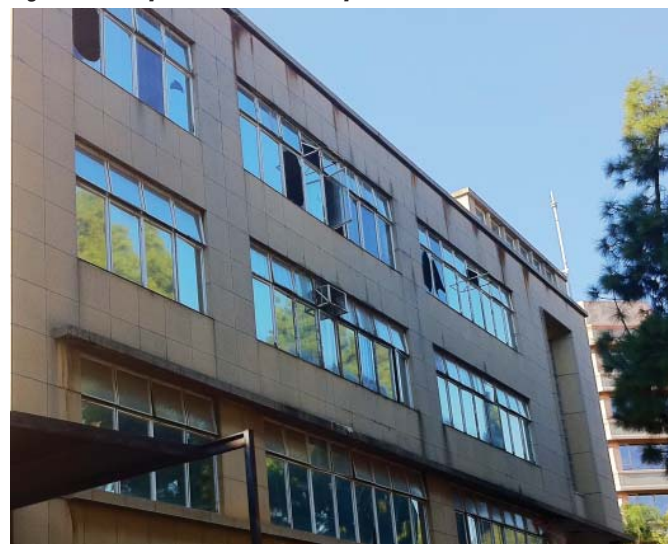

Fig.267:Steel casement windows. [Source: author 2011]

standards of the new occupants. Technology of different materials will however influence the appearance of the windows. Elements such as sun shading applied to the façade of new additions to the complex will be applied to the original building, adding a 21st century layer to the existing façade.

### **Paving**

Bricks bearing the Kirkness insignia will be saved and intended to be re-used in areas of the building . As these are not elements that are of an endangered nature or rare within the context of Pretoria/Tshwane this action is not essential, but preferable (Clarke, 2009).

### **Planting**

No planting with any significance exists on site of the complex. Street planting on Edmond Street is of importance though. This section of Pine tree planting is a continuation of the pines at the Union Building grounds continued down Edmond Street. They are essential to the character and sense of place of this street. The development should not detrimentally affect this planting scheme.



*Fig.268:Paving with Kirkness insignia. [Source: author 2011]*



*Fig.270:Edmond Street framed with pine trees. [Source: author 2011]*



*Fig.269:Pines trees from the landscaping plans of the Union Building [Source: author 2011]*



### AGRIVAAL PHASE 3 BUILDING (1953)

Unlike the first two phases of the Agrivaal/Mealie Board building this phase has very little architectural merit or cultural/historical value and does not add value to the urban environment. It is possible to demolish the whole without any substantial loss of meaning should the whole be documented before demolition.

### AGRIVAAL PHASE 4 BUILDING (1963)

#### COUNCIL CHAMBER

While a high-spec building in its day the Council Chamber has been severely vandalized. It is obsolete and contains very little physical material that should be incorporated in any new development should it be demolished (Clarke, 2009). Further to this the incorporation of breeze block screening walls, such as the one to the east of the Council Chamber, on the pedestrian level will serve as memory of the Council Chamber and evoke the idiom of the Brazil Builds era during which this structure was erected. This building will be kept and serve as an information centre.



Fig.271:Phase 3, with exposed brick. [Source: author 2011]

### 8.5 Outbuildings

These structures will be documented, however have no heritage value. They will be demolished to allow for the proposed intervention.



Phase 4, Council Chamber [Source: author 2011]

## 4.3.6 STATEMENT OF SIGNIFICANCE

### CONTEXT

Existing buildings are records of architectural eras and influences. The city is like a library that retains information on architecture and construction, allowing the public to refer back to the past and integrate it with the present. The Agrivaal Building is a prime example of Modernism with an Art Deco influence. It represents the importance of mealie farming in South Africa. The building retains a layer of the past and represents a layer of knowledge that should be kept and preserved in the city. The building is located on the corner of Hamilton and Edmond Streets, of which the latter lies on Government Boulevard.

Edmond Street forms an important approach to the Union Buildings. The pine trees which line both sides of the street date to c. 1910 (Clarke, 2009). Their purpose was to frame views along a narrow vista from the city to the Union Buildings. Government Avenue is significant because of its close physical association with the Union Buildings, and because it links the city with important sites within Pretoria. It has superb views over Pretoria as well as to the newly developed Freedom Park across the valley (Clarke, 2009). Government Avenue is the gateway to the Union Buildings. Furthermore, the streetscape was never designed or intended to fulfil this function, and today it is being neglected and mismanaged. The value of this area lies in Sir Herbert Baker's original design intent of creating clear and uncluttered vistas to and from the Union Buildings (Clarke, 2009). Numerous tall buildings have been added to the sites surrounding the buildings, leading to them being gradually obscured from certain urban viewpoints.

The current derelict condition of the terrain of the western garden as well as Edmond Street does not provide a suitable approach to the Union Buildings and should be addressed. The majority of the buildings are residential or office buildings that do not open up to the public. The intension is that the new Agrivaal Building should respond to the urban context.

### FORM

Elements to be retained:

The design intension is to identify the old and the new and how they link and work together sustainably. The old must still be understood and appreciated in terms of its merit. The transitional zone between old and new must be identified; it should communicate clearly.

- The corner articulation located on the corner of Hamilton and Edmond Streets is done in an Art Deco manner
- The current Council Chamber was influenced by Brazil Modernism, thus documenting it must be considered
- The courtyard will be utilized mainly for office space. It will be extended towards the west, allowing the courtyard space to include the new structure.
- The existing entrance will be utilized as an alternative entrance for uses such as general information, enquiries, mail services, submission of applications etc.
- The existing lift and staircase will be retained.
- Existing glass blocks must be either maintained or replaced.
- The existing mast will be restored and used for the EU flag. The design of the flags and logo will be expressive of

the identities of the EU and South Africa. These must be visible from both Hamilton and Edmond Streets.

- Existing planters must be retained, maintained, and a system devised to water plants through collected rain
- Existing steel casement windows, especially on the eastern façade, must be restored and sealed to improve airtightness. They must serve to provide waterproofing as well as acoustic value.
- Solar shading must be considered on all necessary façades.
- Balconies that allow for winter sun and shading of the summer sun must be considered for the northern façade.

## FUNCTION

The building is currently derelict and unoccupied. It was previously used as the headquarters of the Maize Board in South Africa. It consisted mainly of offices, with access to a testing laboratory.

The building must accommodate the new European Union Commission in South Africa. It therefore needs to provide the following: the ambassador's office, general private offices and open plan offices, social spaces, meeting spaces, kitchens etc.

### Elements to consider:

- The addition of a basement for secure parking
- The use of public transport will be encouraged. The use of the BRT, taxi feeder systems and bicycles will be encouraged. Safe bicycle parking will be provided.
- All existing stairs must be retained to be utilized as fire escapes.
- It must be ensured that all fire escapes lead to Edmond Street without obstructions.
- A well designed fire strategy must be demarcated.
- The ground floor is a public level, therefore public functions must be made available.
- The safety and position of the reception must be considered, as it allows entry to upper levels. Stairs must be well articulated in order to prevent the public entering the upper levels.
- The reception must be clear and approachable. Clear logic should be applied in terms of the entrance to the building; attaining of information and further reaction ?? must be considered.
- Upper floors are office orientated with a mix of private offices, open networked offices, social spaces, photocopying centres and meeting spaces.
- The ambassador's office must be the most secure. The architect should consider placing it on the top floor, with private access to the open roof garden. Views should be maximized.

## Technology

Building construction:

- The new building will have a light-weight feel, contrasting with the existing heavy terrazzo-clad building. The main materials used will be concrete and steel columns, glass and timber.
- The focus will be on how new materials meet the old and on how the links and joints work.



- Links and joints will represent the merging of the old and new, functioning as one but not necessarily read as one.

## **Environmental**

- solar shading – shading on north, east, west
- ventilation – cross ventilation, night ventilation, stack effect
- heating and cooling – rock store, hot water production
- natural lighting - depending on depth of building, access of light
- water harvesting – water tanks
- water runoff management
- recycling – paper, glass, metals

## **Social**

- Occupant comfort – daylighting, ventilation, noise, thermal comfort, views
- Inclusive environments - public transport, information for public, information occupants, clear signage, toilets, furniture
- Access to facilities – access to BRT and taxi feeder system, access to atm, access to kiosk/canteen/food
- Economic- local material, local skill,
- Institutional- governance, politics – the role that the EU has in south Africa, the meetings that take place in relation to the EU and SA.





# chapter 05

## precedent study

---



## CH2 Building

Melbourne, Australia  
City Council Planners and Design Inc.  
2006

focus: sustainability\_systems approach\_green star rating\_passive design

### Introduction

The CH2 Building was designed to imitate the planet's ecology, which is a complex system of interrelated components (City of Melbourne, 2005). Just as it is impossible to assess the role of any part of this ecology without understanding and considering the greater whole, CH2 comprises many parts that work together to heat, cool, power and water the building, creating a harmonious environment (City of Melbourne, 2005).

### Brief

- a sustainable building
- an example to the city, i.e. a didactic process and building
- to be energy efficient, water conscience and specific in sustainable design
- to provide comfortable working environment

### Design based on ecology and climate

A major focus of the design process for CH2 was to comprehend Melbourne's climate and weather patterns. "An ecosystem responds to its environment and its ability to adapt to take advantage of changing weather conditions contributes greatly to the success of the system" (City of Melbourne, 2005).

It was seen that responding to the site's climatic conditions revealed a range of opportunities for energy efficiency, resulting in some of CH2's most innovative features and systems.

"Melbourne is well known for its 'four seasons in one day'" (City of Melbourne, 2005). This provided an opportunity to design the building around the concept of cold energy storage. The building therefore operates in two seasonal modes, winter and summer, with the added consideration of conditions that operate as day mode and night mode.

*Fig.272: and  
Fig.273:CH2 Building [Source: www.mel-  
bourne.vic.gov.au/Environment/CH2]*



fig.57



fig.58



fig.59



fig.60

**vertical green shading**

Vertical greenery to balcony sides screen low angle sun + filter glare.

**light shelf**

Ambient and direct daylight bounces off external and internal light shelf.

**shading**

Light shelf + balcony floors provide horizontal shading from northern sun.

Internal upward rolling retractable blind controls high level glare.

**timber screens**

Manually adjustable vertically sliding timber screens block direct low angle sun and maintain views.

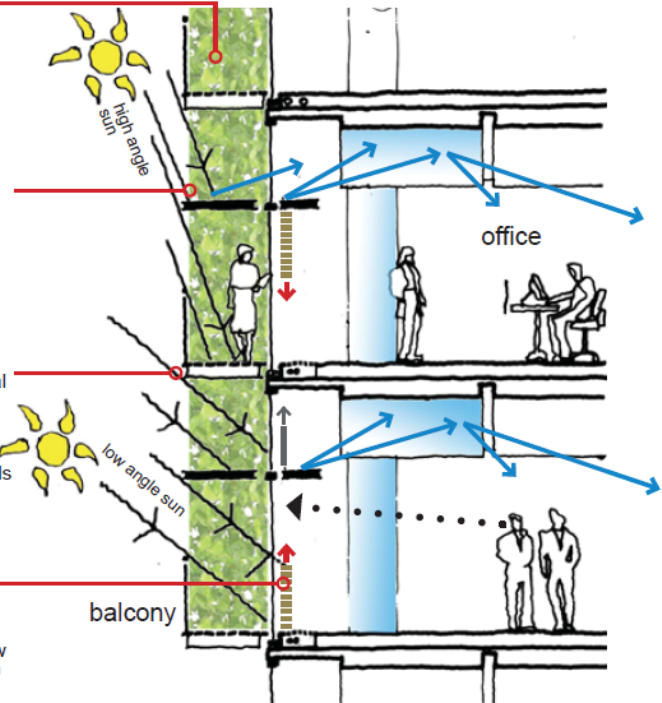

Fig.278: Lighting and Shading [Source: [www.melbourne.vic.gov.au/Environment/CH2/](http://www.melbourne.vic.gov.au/Environment/CH2/)]

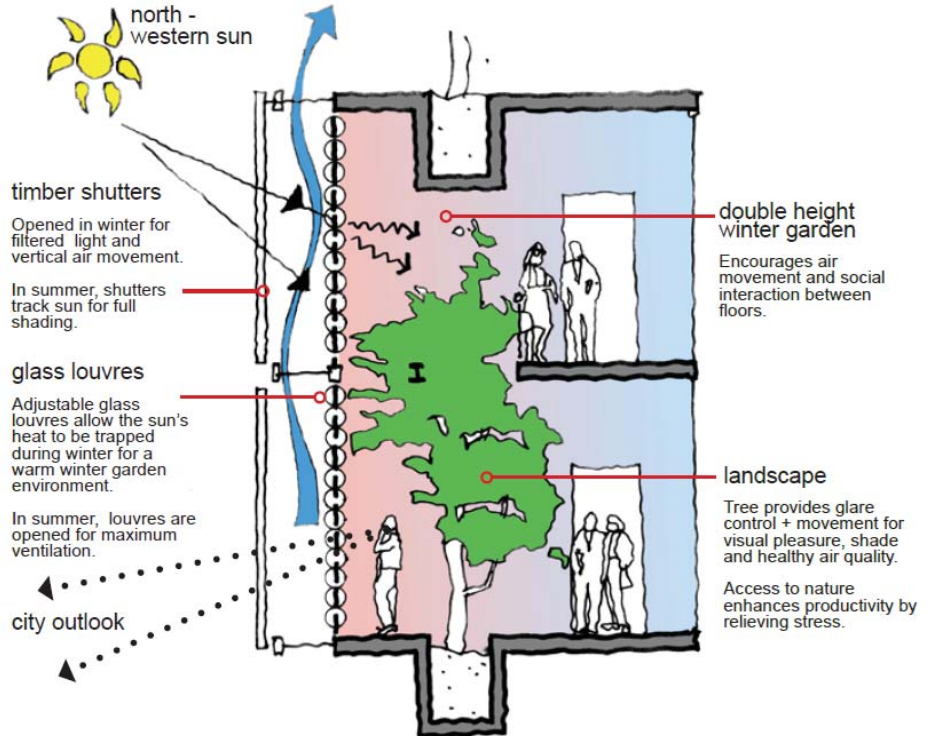

Fig.279: Timber shutters and glass louvres. [Source: [www.melbourne.vic.gov.au/Environment/CH2/](http://www.melbourne.vic.gov.au/Environment/CH2/)]

Fig.274: Vertical garden [Source: [www.melbourne.vic.gov.au/Environment/CH2/](http://www.melbourne.vic.gov.au/Environment/CH2/)]

Fig.275: wind cowl assisting in ventilation [Source: [www.melbourne.vic.gov.au/Environment/CH2/](http://www.melbourne.vic.gov.au/Environment/CH2/)]

Fig.276: and Fig.277: timber louvers [Source: [www.melbourne.vic.gov.au/Environment/CH2/](http://www.melbourne.vic.gov.au/Environment/CH2/)]

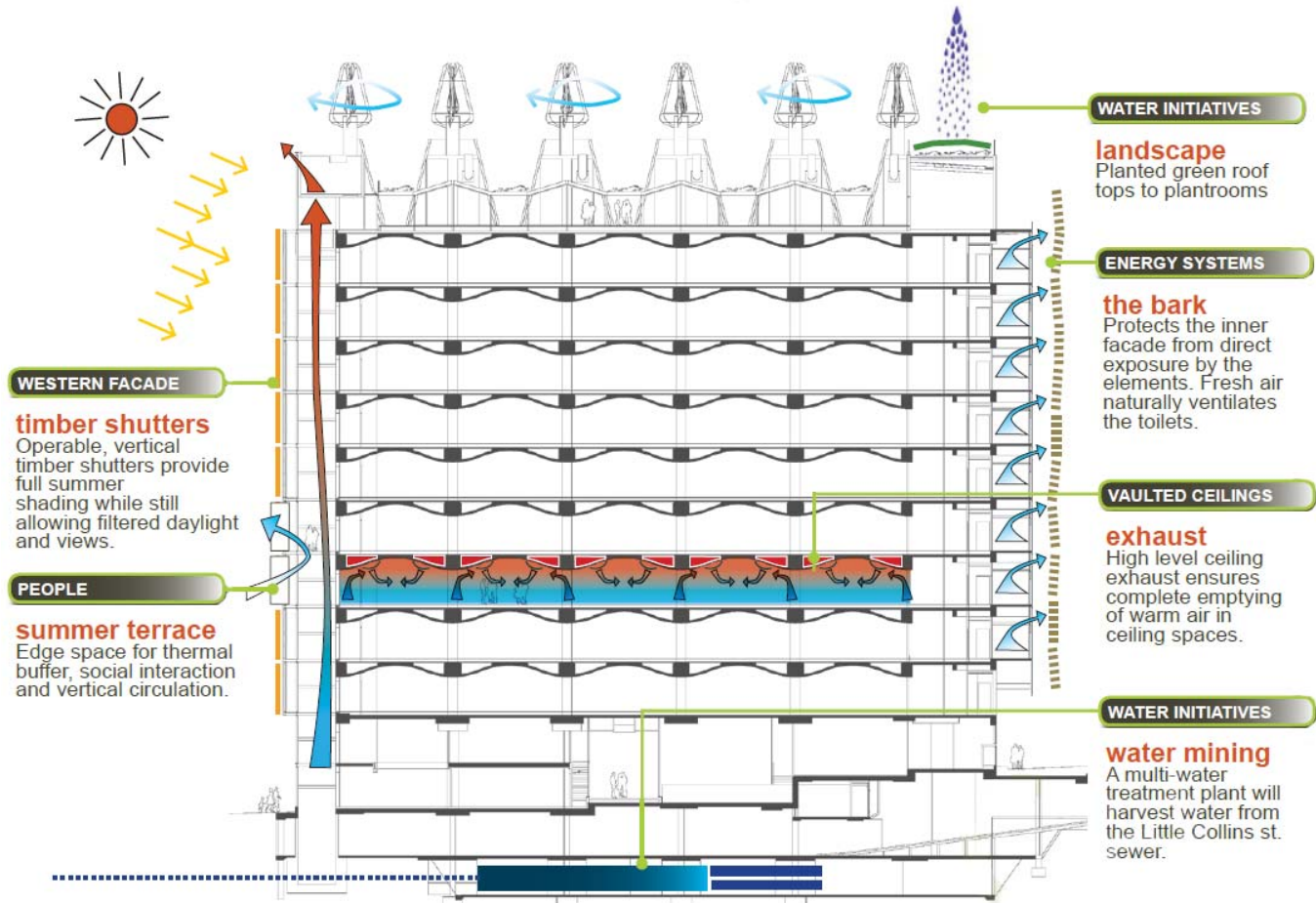

Fig.280:CH2 in Summer Mode [Source: [www.melbourne.vic.gov.au/Environment/CH2/](http://www.melbourne.vic.gov.au/Environment/CH2/)]

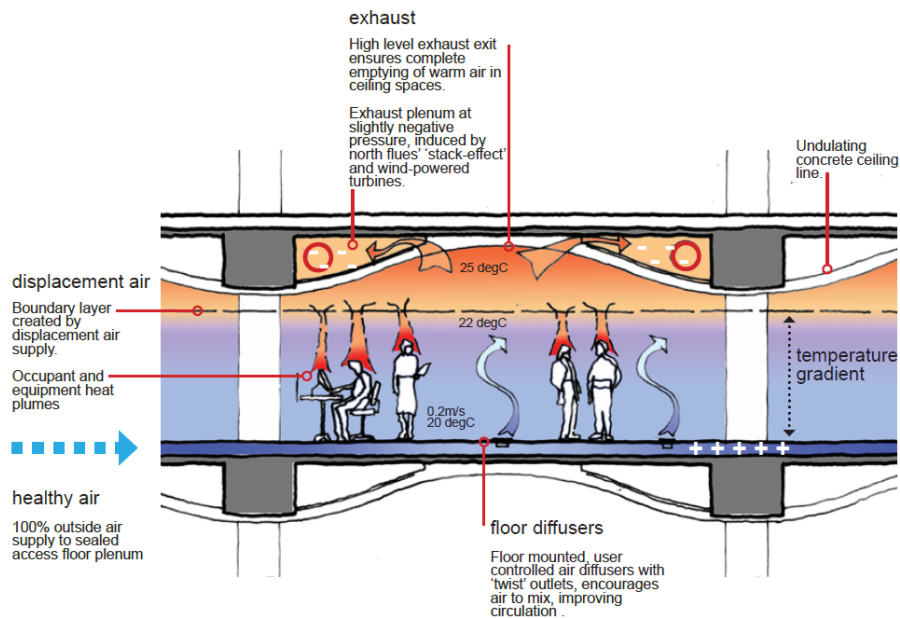

Fig.281:Heating and Cooling through the Ceiling[Source: [www.melbourne.vic.gov.au/Environment/CH2/](http://www.melbourne.vic.gov.au/Environment/CH2/)]

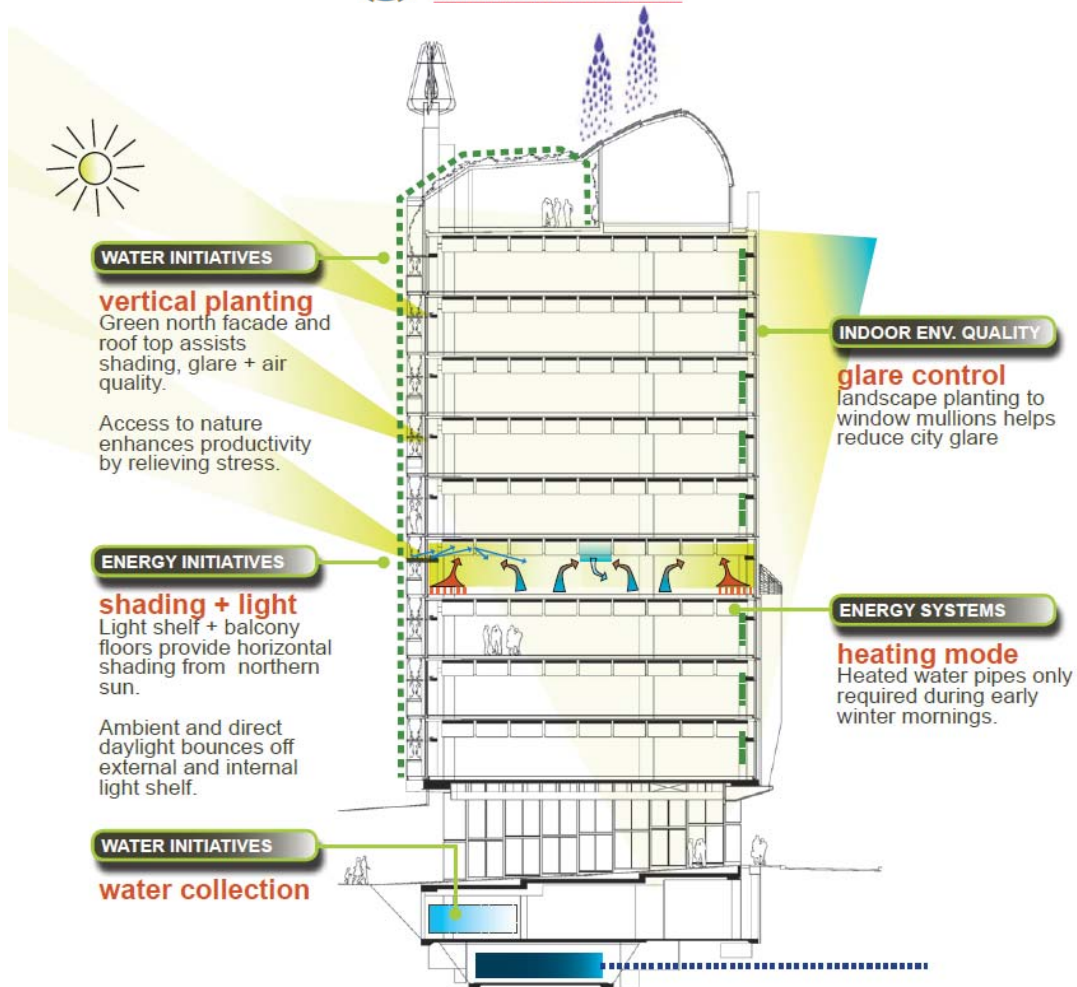

Fig.282:CH2 in Winter Mode [Source: [www.melbourne.vic.gov.au/Environment/CH2/](http://www.melbourne.vic.gov.au/Environment/CH2/)]

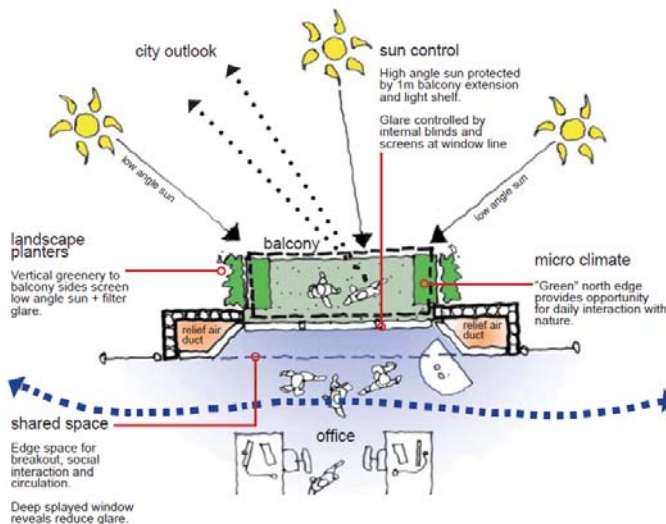

Fig.283:Vertical Garden and Balcony Condition. [Source: [www.melbourne.vic.gov.au/Environment/CH2/](http://www.melbourne.vic.gov.au/Environment/CH2/)]

### Conclusion:

The design process of the Agrivaal Building will take into consideration the different modes in which the overall building can function, thus reacting to seasonal and daily changes in the environment. This will allow for higher occupant comfort levels within the building. It is clear that the CH2 Building tries to mimic systems of nature, resulting in energy efficiency, self-sufficiency and comfort. The Agrivaal Building will consider all the above systems and interpret them according to the climate of the City of Tshwane and the needs of the building itself.



fig 67



fig 68

Harmonia Office Building  
São Paulo, Brazil  
Tryptique  
2010

Focus: passive design\_

## Introduction

The project in Harmonia Street is located in a neighborhood on the west side of São Paulo. It is an office building with planted facades irrigated by a mist system that uses recycled water from the roof garden. The building demonstrates sensitivity towards systems in nature, mimicking them in architecture.

## Brief

- a building that demonstrates systems that work with nature
- energy efficient
- recycling of water

## Like a Living Body

Compared to a living body, the building breathes, sweats and modifies itself (Harmonica 57 by Triptyque, 2008). The walls are thick and covered externally by a green layer that works like the skin of the structure. This dense wall is made of an organic concrete that has pores, where several plant species grow, giving the facades a unique look (Harmonica 57 by Triptyque, 2008).

Rain and soil waters are drained, treated and reused, a complex ecosystem is formed in its surroundings. The pipelines that serve the whole building – as well as the pumps and the water treatment system – are showing in the exterior walls, embracing them like veins and arteries of a body (Harmonica 57 by Triptyque, 2008).

## Conclusion

The recycled water system will be adapted to suite The Agrivaal Building.

*Fig.284:and*  
*Fig.285: Harmonia 57 Office Building*



Fig.288:Pipes that form part of the water recycling system in Harmonia 57 [Source: <http://www.architonic.com/aisht/harmonia-57-triptyque-architecture/5100477>]



Fig.289:Accessible roof [Source: <http://www.architonic.com/aisht/harmonia-57-triptyque-architecture/5100477>]



Fig.290:3D renderings envisioned by architects [Source: <http://www.architonic.com/aisht/harmonia-57-triptyque-architecture/5100477>]

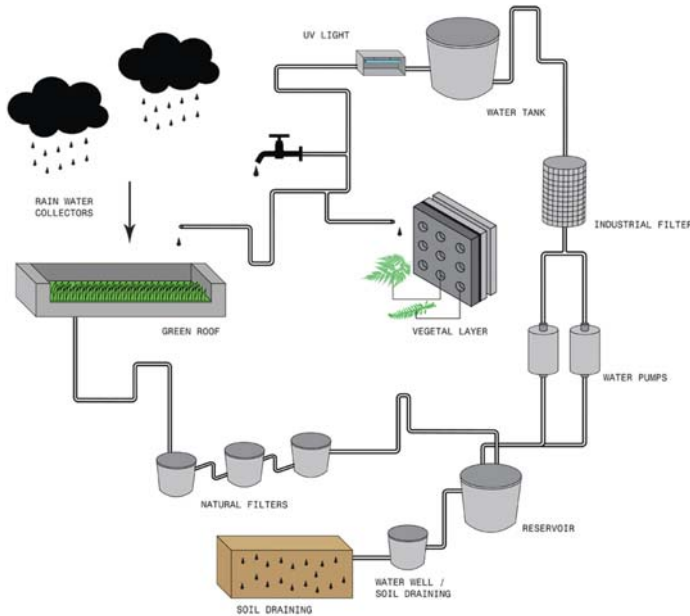

Fig.286:Water recycling system of Harmonia 57. [Source: <http://www.architonic.com/aisht/harmonia-57-triptyque-architecture/5100477>]

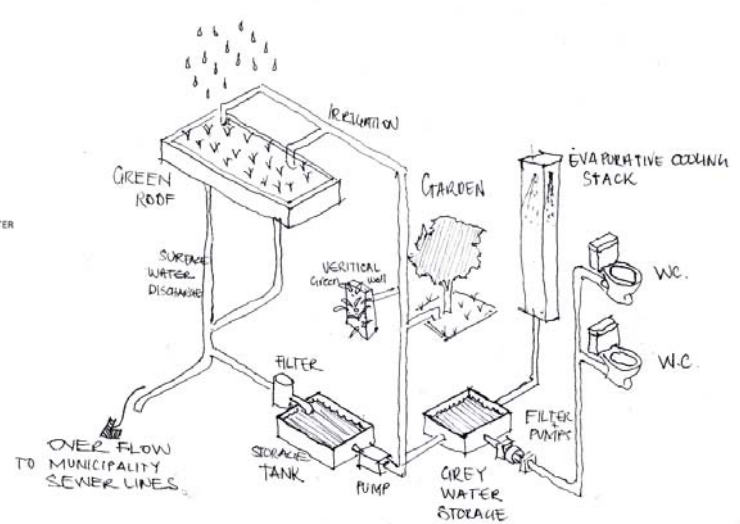

Fig.287:Proposed recycle sytem for the Agrivaal Building, using the Harmonica and Central Saint Giles building. [Source: <http://www.architonic.com/aisht/harmonia-57-triptyque-architecture/5100477>, edited by author 2011]



Fig.291:VIP drop off point [Source: [www.bdp.com/Projects/By-Name/P-Z/Umoja-House/](http://www.bdp.com/Projects/By-Name/P-Z/Umoja-House/)]

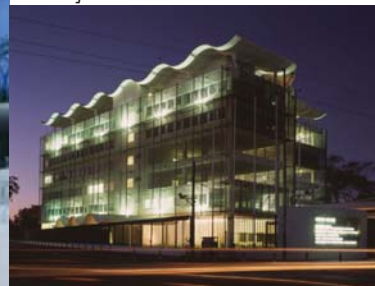

Fig.292:night view [Source: [www.bdp.com/Projects/By-Name/P-Z/Umoja-House/](http://www.bdp.com/Projects/By-Name/P-Z/Umoja-House/)]

Fig.293:Main entrance of Umoja House

## Umoja House

Dar es Salaam, Tanzania  
Manser Practice, London  
2002

focus: embassy building\_security\_entrance points\_louver system\_African city

### Introduction

The Umoja House accommodates the British High Commission and embassies of Germany and The Netherlands. It also houses the European Commission in Tanzania (BDP, 2011). The Manser Practice won the design competition. The 4,000m<sup>2</sup> building was designed for a high level of security and employs passive environmental controls to maintain comfortable naturally ventilated interior spaces.

### Brief

- to create a secure building
- to build to European standards in a developing country
- to respond to an extremely aggressive climate
- to provide the client with comfortable internal conditions

### A fitting response to the city and its climate

Protection against the climate pervaded all aspects of the design. To prevent overall heat gain the design has a floating solar roof and external louvers to three elevations.

Materials were sourced locally wherever possible, and supported supplied? via local agents and contractors (BDP, 2011). Metal mesh screens articulate three of the facades of the building. In all cases the mesh systems act as solar screens, maintaining protection from the sun. The screen mesh also acts as a protective skin, allowing for effective ventilation.

There are two major entrances to the compound, i.e. public and staff entrances. Each entrance is highly supervised and controlled by guards and CCTV as well as metal detectors.

### Conclusion

Security is an important factor while designing for the proposed intervention of the Agrivaal Building. Check points and minimal access points to the building must be adhered to as clients are of high importance as political issues may cause life threatening situations.

Climate control is an important feature that the new intervention will explore. The Façade and boundary fence work in unison at the Umoja House. The two elements are visually permeable, but provide security and solar shading.





Fig.295: Access points at the Umoja House [Source: www.bdp.com/Projects/By-Name/P-Z/Umoja-House/]

Security is a high priority at the Umoja House. There are two entrance/exits into the complex. The main entrance receives visitors into the building. The second entrance is for people who work in the building, as well as accommodating for services.

Both access points to the site are monitored by CCTV, and have guards monitoring movement in and out of the building. The main entrance has a pedestrian check point, where a person entering is searched and clears the security check. They are directed to the main reception, who notifies the requested embassy. The visitor is either ushered or directed to the required floor and meets a second security check allowing them into the offices of the desired embassy.

A car entering the compound through the main entrance is usually VIP visitors. Depending on the guest, different security checks and protocols are executed.

The back entrance usually accepts service vehicles and people working in the offices in the building. High security checks are performed before entering.



Fig.294: louvers, fencing, roof. [Source: www.bdp.com/Projects/By-Name/P-Z/Umoja-House/]

→ CONCRETE ROOF ALLOWING FUNCTIONS ON ROOF TOP. - SHADED FOR HOT SUN

→ STEEL LOUVRED SCREENS.  
- SOLAR CONTROL  
- SECURITY  
- FACADE LANGUAGE - UNITY OF FACADE  
- ALLOWS FOR OPENABLE WINDOWS FOR FRESH AIR WITH STILL BEING SECURE.

→ WAVE TYPE STRUCTURE ALLOWS FOR AIR MOVEMENT WHILE PROVIDING SHADE AND PROTECTION FROM RAIN AND WIND.

→ BOUNDARY FENCE - SIMILAR LANGUAGE TO STEEL LOUNGES ON FACADE. VISUALLY PERMEABLE - SEEMING ACCESSIBLE AND OPEN (NOT HIDING - OPEN TO PUBLIC)



Fig.296: Turbine Hall [Sourced: [www.conference-venues.co.za/gjhb\\_forumturbine.htm](http://www.conference-venues.co.za/gjhb_forumturbine.htm)]

## Introduction

focus: heritage\_

The original Turbine Hall is considered one of the finest examples of industrial architecture in Johannesburg, occupies a land mark site in Newtown, situated at the “gateway to Newtown” on Miriam Makeba (formerly Bezuidenhout) and Jeppe Streets (Turbine Hall, 2004). It is a listed heritage site, but over the years had fallen into serious decay. Its development has been an important symbol of the progressive realisation of the Newtown revitalisation vision.

For many years the neglected building was home to a large number of squatters who were subsequently relocated in 2000. The occupation of the building by squatters has resulted in some structural damage to the building, which stood until April 2002, when minor repairs (the replacement of the roof and cleaning of the boiler room) were undertaken to enable the facility to be utilised for major events in Newtown (Turbine Hall, 2004).

## Brief

- rehabilitation of the building
- to be part of the reverse the decline of western sector of Johannesburg (Turbine Hall, 2004).

## Design

The design concept was to provide offices and needed space while preserving the spirit of the existing Turbine Hall. This was achieved by demolition of one structure to create a underground parking. New buildings relate to the existing complex in a way that makes them spatially and functionally interdependent (Krige & Beswick, 2001:99). New work has been painted, while existing structure is left in its original state.

## Demolition

The Heritage Impact Assessment (HIA) concurs with the proposed demolition of one of the three buildings on site put forth by AngloGold Ashanti. The space allowed for underground parking that is hidden and not a structure that would overpower the existing Turbine Hall, which is the tallest building on the compound (Krige & Beswick, 2001:90).

## Burra Charter

The principles of the Burra Charter provided guidance on the conservation of cultural significance in the Turbine Hall. The charter discourages demolition of culturally significant fabric of place, however in this case it is



fig 75



fig 76

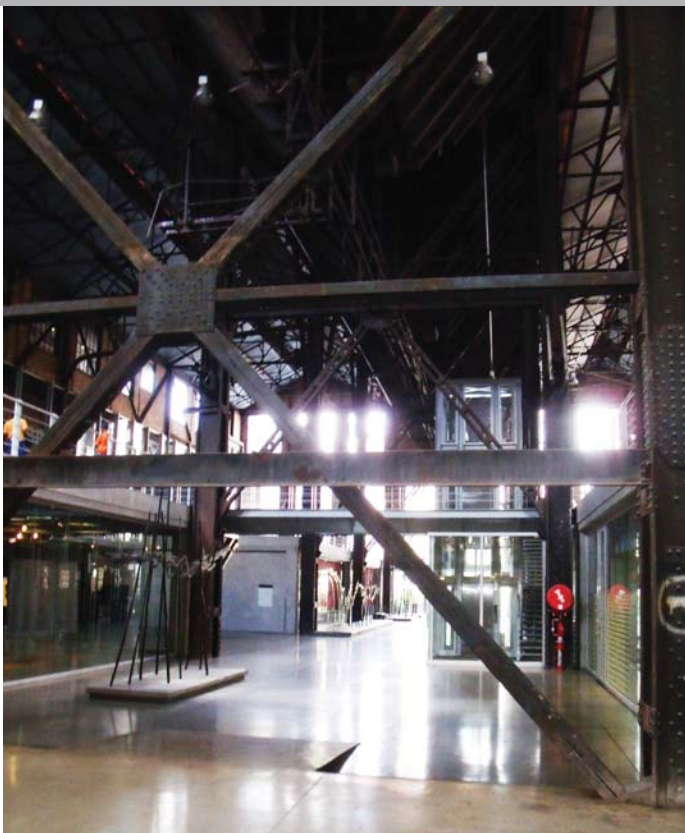

fig 77

*Fig.297:g Gass box inside concrete shell [Source: author]*

*Fig.298:New ballustrade connected to existing co-loumn. [Source: author]*

*Fig.299:Plaque: information of the heritage of the building. [Source: author]*



*Fig.300:Existing steel bunker. [Source: author]*



*Fig.301:New glass partitioning with aluminium frames. [Source: author]*

appropriate as it allows for conservation of the complex (Krige & Beswick, 2001:91).

## Conclusion

The new work in the Turbine Hall is clearly distinguished. The memory of the old building has been retained and enhanced by the use of steel structures lightly hovering over the existing concrete beams. The use of the Burra Charter enable well informed decisions allowing for functional spaces and conservation of existing structures.



## New York Times

New York, USA  
Renzo Piano Building Workshop and Fox & Fowle Architects  
2005

Among the most prominent of the building's "green" features is the unique open-air garden, the first of its kind in Manhattan. The garden, which is surrounded by glass, features a grove of 16 m paper birch trees, a ground covering of autumn fern, and an elegant wooden footbridge. Visible from the lobby, the building's offices and the street, the garden is a calm and serene environment, a 'green' oasis in the middle of one of the busiest, most densely packed neighborhoods in New York (Fox and Fowle Architects, 2002).

### Double-Skin Curtain Wall

To reduce the amount of heat coming into the building, architect Renzo Piano envisioned a second skin of horizontal ceramic rods that act as a sunshade, sufficient in number to block half of the sun's energy (Fox and Fowle Architects, 2002). This is the first time this type of double-skinned curtain wall has ever been used. By deflecting the heat, the double curtain wall allows use of floor-to-ceiling ultra-clear glass that maximizes views and light for occupants of the building while allowing people outside the building to see movement within (Fox and Fowle Architects, 2002). The ceramic rods also enhance the design by gently reflecting light and color changes throughout the day (Fox and Fowle Architects, 2002).

focus: double skin\_security\_shading structure\_signage

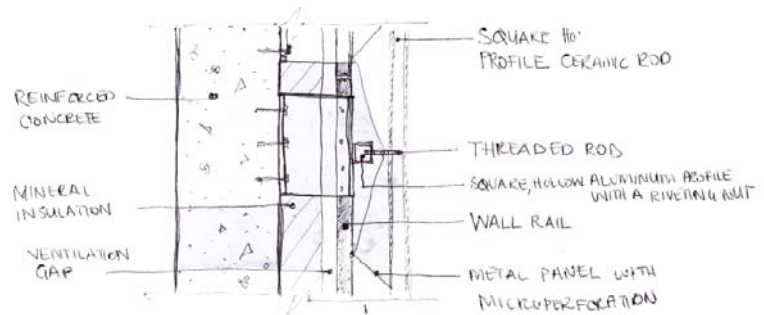

Fig.302: Detail of ceramic solar shading structure. [Source: <http://www.architectmagazine.com/exterior/brandhorst-museum.aspx>]

position of second skin



Fig.303: Section showing position of shading system [Source: <http://www.arcspac.com/architects/pianoNYT/>]



Fig.304: Entrance of the New York Times Building [Source: [www.arcspace.com/architects/piano/nytt/](http://www.arcspace.com/architects/piano/nytt/)]

Fig.305:Lobby Entrance [Source: [www.newyorktimesbuilding.com/](http://www.newyorktimesbuilding.com/) Photograph by Kenzo Hsieh (HSUEH-HSIEN HSIEH), 2007.]



Fig.306:Lobby Entrance [Source: [www.newyorktimesbuilding.com/](http://www.newyorktimesbuilding.com/) Photograph by Kenzo Hsieh (HSUEH-HSIEN HSIEH), 2007.]

Fig.307: and Fig.308: [Source: [www.arc-space.com/architects/piano/nytt/](http://www.arc-space.com/architects/piano/nytt/)]



# chapter 06

## client and brief

---



*Fig.309:European Union flags outside the European Commission headquarters building in Brussels, Belgium. [Source: [www.royalgazette.com/article/20110623/BUSINESS04/706239907&source=RSS](http://www.royalgazette.com/article/20110623/BUSINESS04/706239907&source=RSS)]*

## 06\_the delegation of the European Commission

The Commission is a key EU institution. It alone has the right to draw up proposals for new EU legislation, which it sends to the Council and Parliament for discussion and adoption (Fontaine, 2010: 26). The Commission is must answer to the Parliament. There is one Commission member ('Commissioner') from each EU country, including the Commission President and the High Representative of the Union for Foreign Affairs and Security Policy, who is one of the Commission's vice-presidents.

On 9 February 2010, the European Parliament voted to approve the new Commission. The former Prime Minister of Portugal, José Manuel Barroso, was reappointed President of the Commission for a second five-year term (Fontaine, 2010: 26). The Commission enjoys a substantial degree of independence in exercising its powers. Its job is to uphold the common interest, which means that it must not take instructions from any national government. As 'Guardian of the Treaties', it has to ensure that the regulations and directives adopted by the Council and Parliament re being implemented in the member states. If they are not, the Commission can take the offending party to the Court of Justice to oblige it to comply with EU law (Fontaine, 2010: 26).

As the EU's executive arm, the Commission implements the decisions taken by the Council in areas such as the common agricultural policy. It has wide powers to manage the EU's common policies, such as research and technology,

overseas aid and regional development. It also manages the budget for these policies (Fontaine, 2010: 26).

The Commissioners are assisted by a civil service, based mainly in Brussels and Luxembourg, divided into 43 departments and services. There are also a number of agencies, set up to carry out specific tasks for the Commission in other countries.

## What is the European Union and what does it believe in?

- The European Union is the world's leading trading power and therefore plays a decisive role in international negotiations, such as those among the 153 member countries of the World Trade Organisation (WTO), or at the United Nations conferences on climate change.
- The EU takes a clear position on sensitive issues affecting ordinary people, such as environmental protection, renewable energy resources, the 'precautionary principle' in food safety, the ethical aspects of biotechnology, the need to protect endangered species, etc.
- The EU remains at the forefront of global efforts to tackle global warming. In December 2008 it unilaterally committed itself to a 20 % cut in greenhouse gas emissions by 2020.
- The EU believe in relationships countries outside Euopre, provided trade opportunities and assistance to developing countries.

## What is the European Commission doing in South Africa?

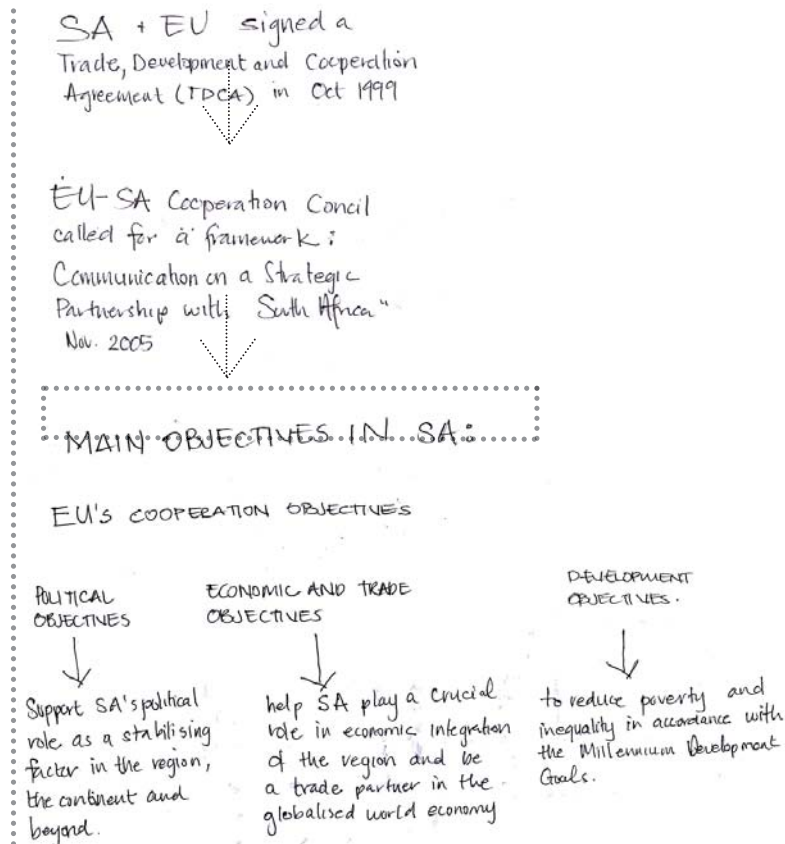

Fig.310: diagram indicating the function of the EC in South Africa [Source: www.eusa.org.za/]



# How does the Delegation of the European Commission in South Africa want to be perceived?

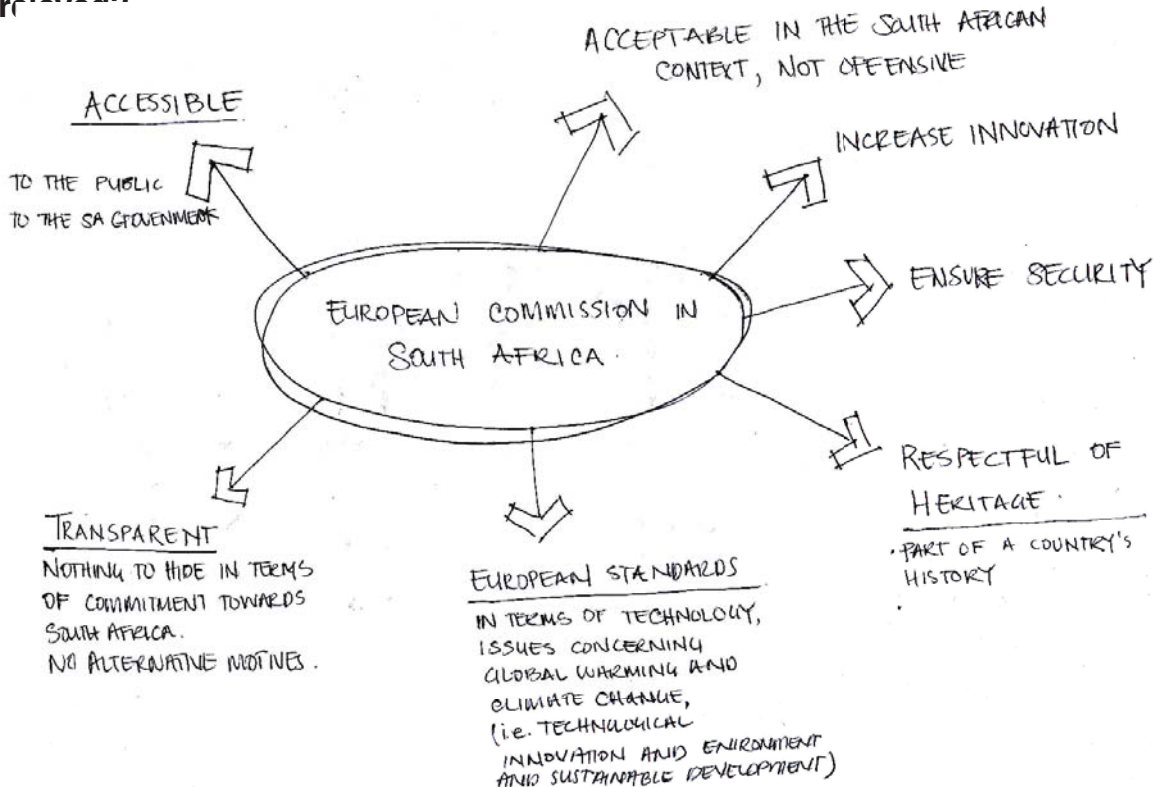

Fig.311: Diagram showing a proposed view on how the EC want to be perceived in South Africa [Source: author]

# What are their needs in terms of a new building? (spaces/functions)

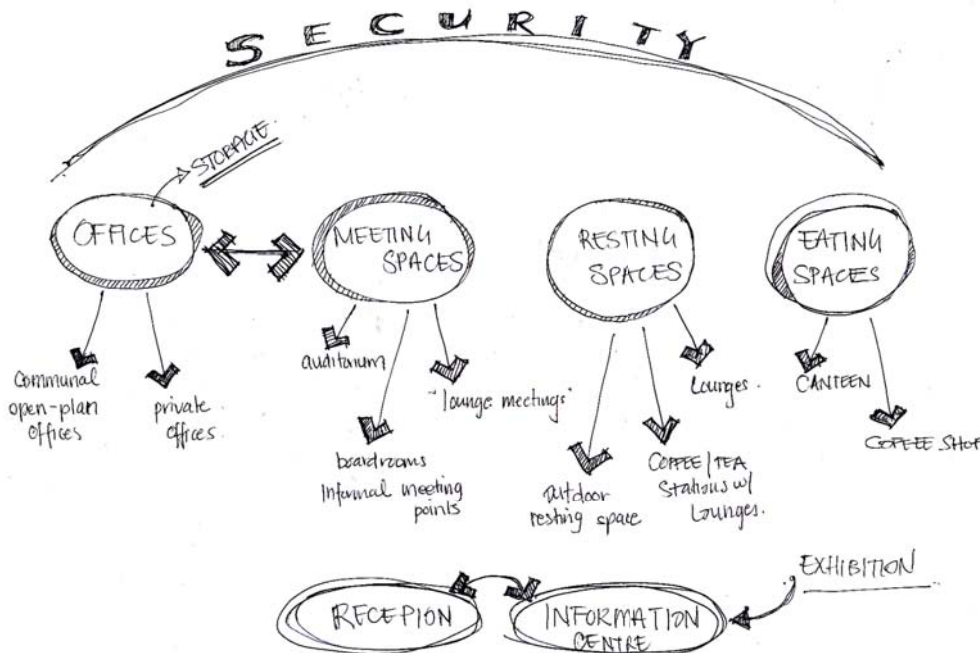

Fig.312: Simplified diagram on the needs of the new building [Source: author]



## Who will use this building?

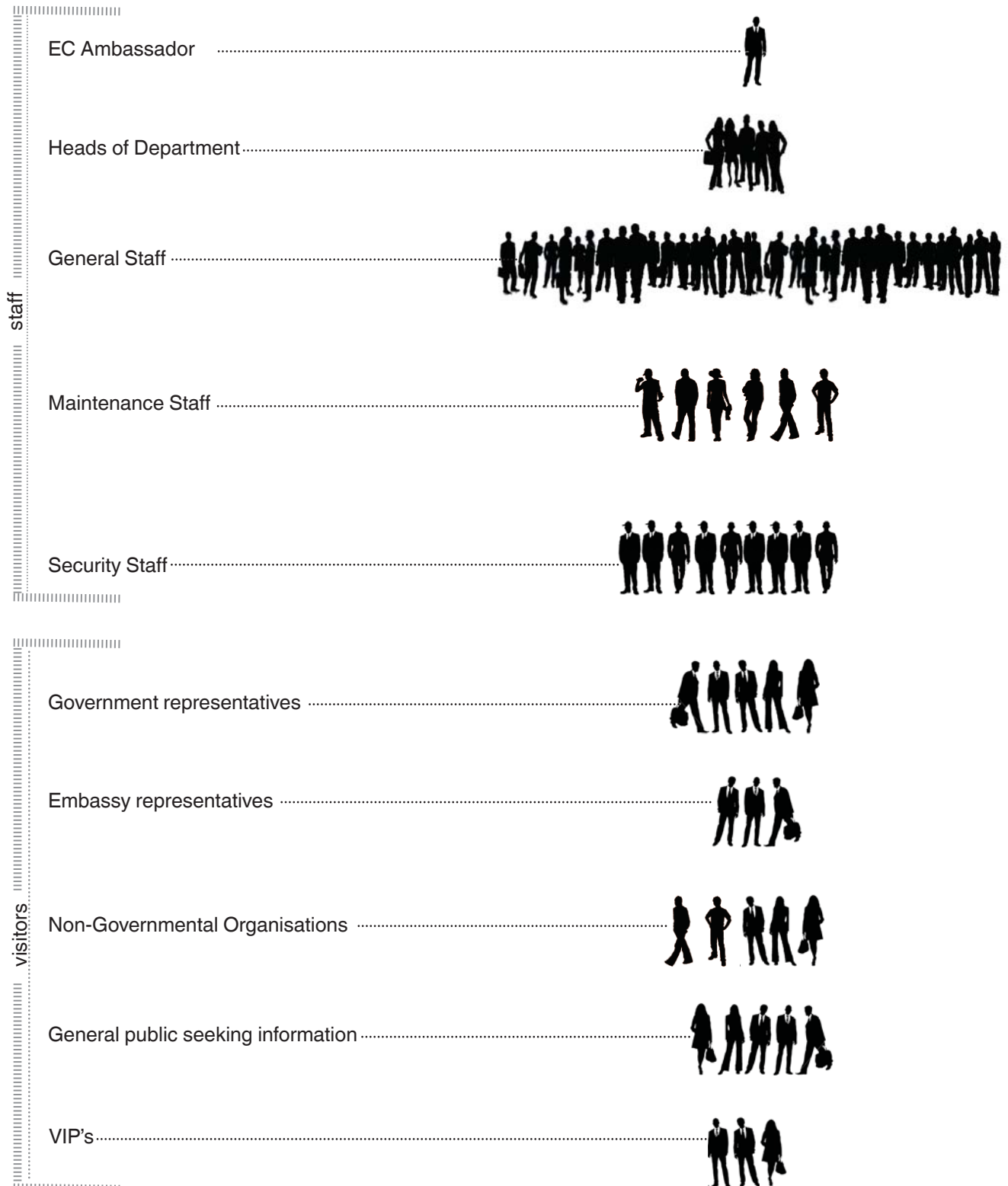

Fig.313: Diagram showing the users of the uilding [Source: author]

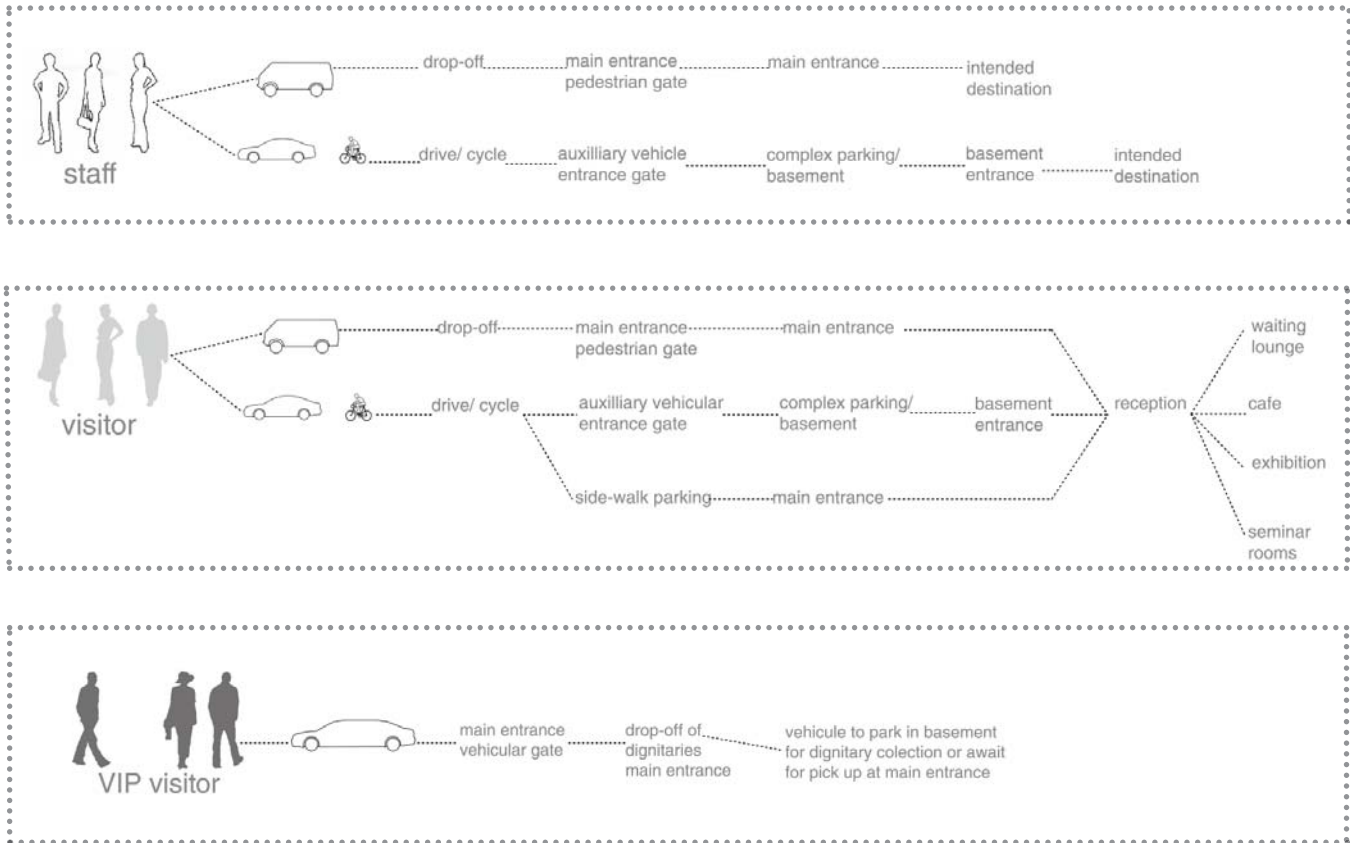

Fig.314:Diagram of proposed ways the people will enter the building [Source: author]

# Brief

The intervention must present well functioning and requested space that provides for the Delegates of the European Commission in South Africa. The adaptive reuse of the Agrivaal Building will use informants of environmental sustainability and heritage as guiding principles in the design.



# chapter 07

## design development

---

# 07\_design development

## Introduction

The hypothesis and main research question (chapter 2) are further being investigated in this chapter. It will specifically look at design generators, informants and decisions in terms of the proposed new intervention of the Agrivaal Building. Focus on the design development from a conceptual point, proceeds to a more physical and realistic design proposal for the new European Commission. The European Commission identifies itself with sustainable development, with a large focus on the environment and it's awareness and sensitivity towards it. Thus a major influence in the design proposal.

## Architectural goal:

adaptive reuse of a dormant building

## Purpose of intervention:

reuse an existing building with the intension of respecting it's heritage and using principles of environmental sustainability.

## Programmatic intension:

to design the new head offices of the European Commission in South Africa, that will reflect their interests in sustainable development and sensitivity to environmental issues.

## Design Generators

### Concept

The concept and design guide for the intervention of the Agrivaal Building stems from the theoretical investigation of heritage and environmental sustainability. These the linking of the informants become the premise of the design. Thus 'Sustainable Heritage', in terms of this project refers to the adaptive reuse of an existng building in a manner that respects the environment and the surrounding context.

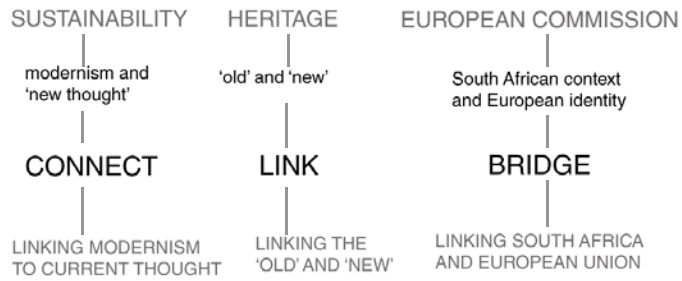

**LINKING**



**Sustainable Heritage**  
Utilizing existing buildings in a manner that respects the environment

informants

concept

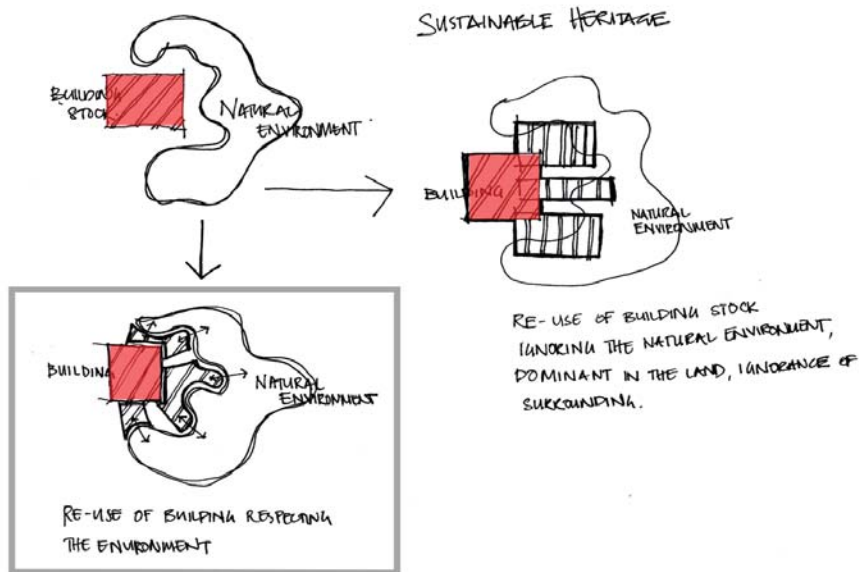

Fig.315:Diagram of concept, Sustainable Heritage [Source: author]

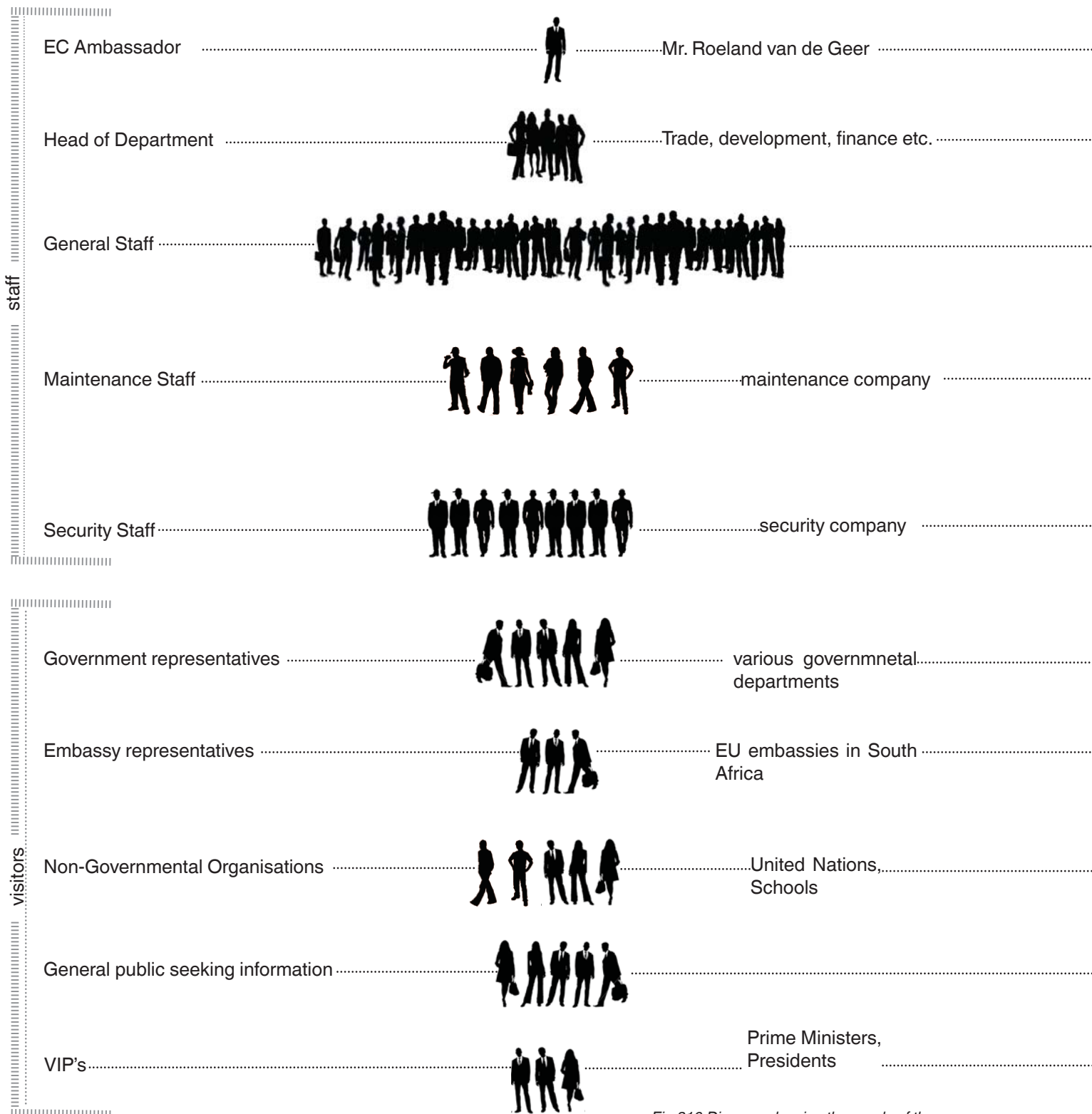

Fig.316:Diagram showing the needs of the user



special needs

space needed

estimated sqm

private office  
security  
Personal Assistant

Private office linick to  
personal assistant and  
boardroom

100sqm

private office with  
access to open plan offices

10sqm

will mostly use open plan offices with  
some in private office depending on  
department

150sqm

office and storage for tools and  
machines. Changeroom and showers  
provided.

90sqm

office and storage for tools and  
machines. Changeroom and showers  
provided.

90sqm

meeting spaces/  
boardrooms

information centre

150sqm

secure lounge used as  
waiting point until ushered to  
destination. The secure lounge  
is also designed to be the 'safe  
zone' incase of an attack.

meeting spaces/  
boardrooms

200sqm



## Types of Office Spaces

The vignettes below are of different office meeting and working spaces that will be incorporated in the design. These drawing communicate the idea of mundane scenarios in an office building, however collectively create a function office as a whole. Concept of vignettes is sourced from [www.officespace.com](http://www.officespace.com)



Fig.317: open plan office



Fig.320: private office

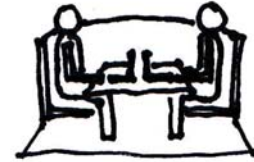

Fig.323: partitioned work space



Fig.318: partitioned group offices layout



Fig.321: private shared office



Fig.324: quick work point



Fig.319: cubicle- semi enclosed



Fig.322: private shared office

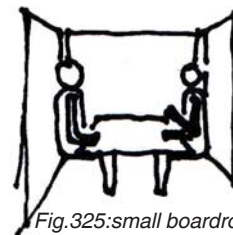

Fig.325: small boardroom



Fig.326: large boardroom



Fig.330: quick meeting point



Fig.334: locker area



Fig.327: small meeting space

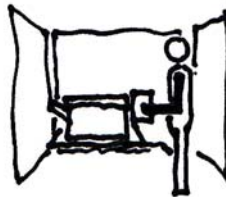

Fig.331: xerox room

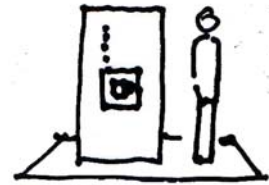

Fig.335: coffee/tea area



Fig.328: large meeting space



Fig.332: filing space



Fig.336: waiting area



Fig.329: boardroom facilities

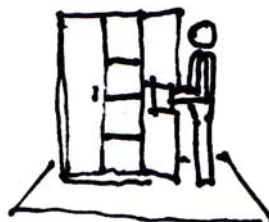

Fig.333: storage space



Fig.337: smoking room/area

## Design Progression

This project engages with the adaptive reuse of the Agrivaal Building in a manner that responds to the needs of the client, respect and sensitivity to cultural heritage and environmental sustainability.

The success of the design will be tested on the following:

- The building working/functioning as a whole
- Security within the building
- Identity
- Environmental systems in the building
- The contrast between existing building and new intervention
- Comfort: working spaces, resting spaces, eating spaces

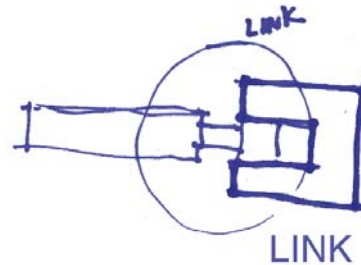
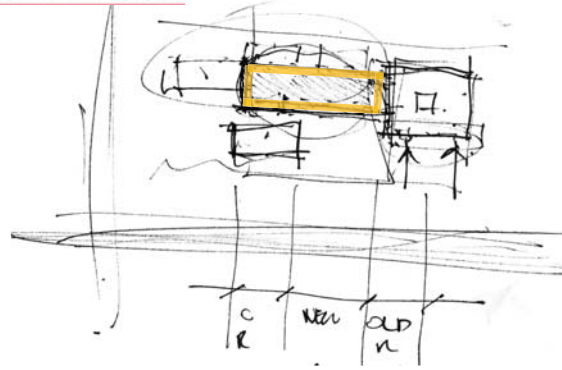

## Form Development

The form and general massing of the new intervention is derived from a number of factors including site analysis and building analysis. The initial focus is to open the courtyard building (phase 1 and 2) into phase 3 allowing for a large atrium space. This allows the link between the two phases in a subtle manner. It also allows visual access between the two buildings.

The second major form that was designed was the auditorium. This is a floating mass supported by pilotis. It is informed by the council chamber positioned in front of it. The height of the building is slightly lower than the rest of the building. This was to respect the main courtyard building, which is benchmark height that the intervention works from. The intension is to keep most of the buildings mass just below the courtyard building, highlighting the importance of it, as well and bringing focus to the corner articulation of the building (high cultural significance).

Proportions were of importance in deciding the form since the the new building must relate to and existing form.

## Proposal 1

The project developed through numerous site visits, site and building analysis of the Agrivaal Building. The

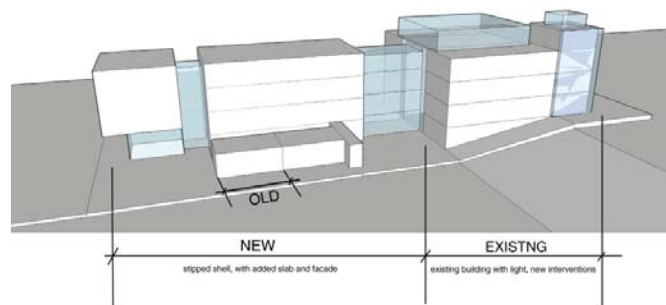
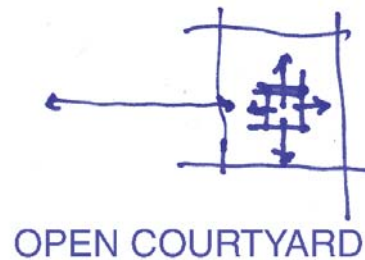

opportunities presented were limited if no demolition was considered. The Burra Charter assisted in the analysis of the building in terms of cultural significance, thus an and informed decision was made on demolition. Phase 3 to be stripped of it's façade and work with its existing columns and slab. According to the HIA, the building was analyzed by an engineer, deeming it structurally sound, and safe to add more weight onto the columns and foundations.

The semi-basement initially was proposed to serve as parking. This presented a very limited parking bays, however allowed for direct entrance to the building, which was needed for important and 'high security' guests. Other possibilities were explored, and will be mentioned in the next proposal.

## Proposal 2

The second proposal responded to the need of a new, pronounced entrance between the courtyard building (phase 1 and 2) and the brick addition (phase3) building. The position seems to be appropriate, allowing an opportunity to demonstrate the intended link between old and new. Phase 3 of the Agrivaal Building is of low cultural significance and thus demolition in some areas would be acceptable. Before entering the building through the main entrance there is a small semi-public square, allowing for a pause, just before the four storey entrance. When entering the complex after a security check, it is the option of the user to either enter the large entrance presented as on moves forward. The other option would be to enter a smaller building, the existing council chamber which is proposed to be the new information centre. The information centre frames the square allowing the for an intimate semi-public space, visually accessible to the street.

In terms of proportion, a number of concepts were explored. The corner articulation of the courtyard building is the main attraction of the existing building, thus the height of the new building should not compete. The new building is the phase 3 column and slab with added floor space and new articulation of facades (north and south facades).

In terms of material, the link between old and new at the new entrance of the building (link between courtyard building and new building) will in contrast to the heavy existing terrazzo cladding be articulated with steel and glass. This will allow for transparency and natural light into the knuckle of the building.

This response, and initial attempt in design proposes that

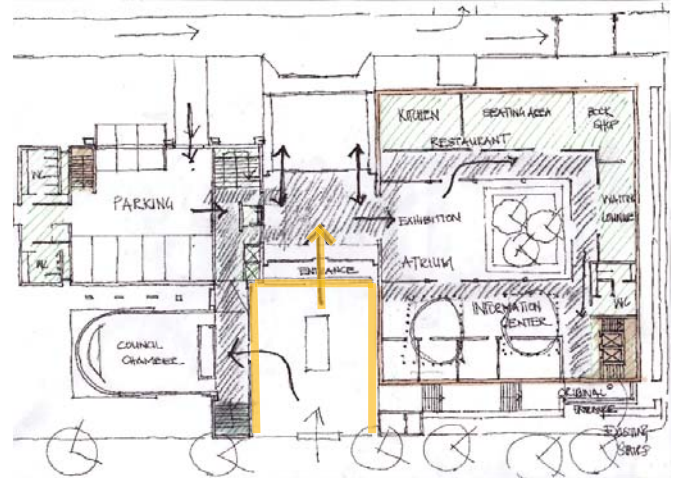

Fig. 338: proposed ground floor [Source: author]

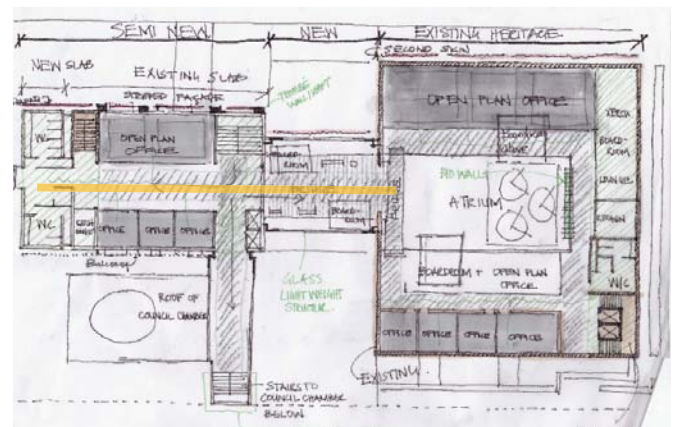

Fig. 339: proposed first floor [Source: author]

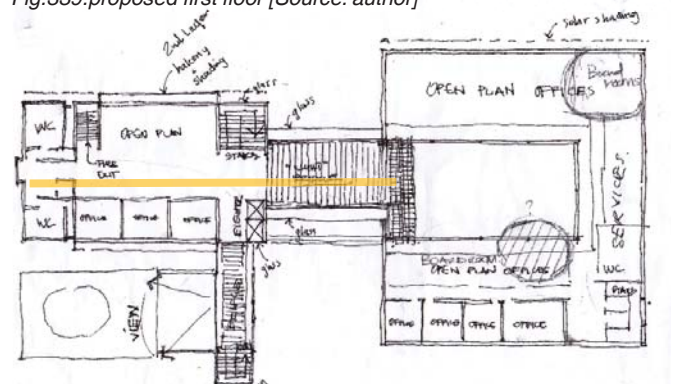

Fig. 340: proposed second floor [Source: author]



the existing concrete roof becomes another office floor. The idea of a new roof structure with roof sheeting was considered and explored. Water recycling methods were considered at this point, where water can be directed towards water tanks for use within the complex.

### Proposal 3

The third proposal focused on the link between the new building and the council chamber that sits to the south of the new building. The council chamber is a quaint and small structure that speaks of the early Modern era, with influence of Pretoria Regionalism. This building has two floors with as semi basement as the lower floor. The semi basement will be utilized as the security office, and the floor above will be the information centre. The link between the council chamber and the new building will be a wide passage, allowing visual access into the square. This passages frames the square at main entrance of the building.

### Proposal 4

Proposal four looks and the systems of the building. The influence of security, heating and cooling, ventilation and façade treatment. This process re-evaluated many issues in the building, moving openings, creating new spaces, etc. This stage of designed force the holistic view of the building. As informed design decisions were made previously, the detailed systems confirmed and justified, or rejected the idea or concept.

### Security

The security in the building considers three major categories of users within the building. There are the staff that work on a day to day basis. Visitors will be expected, in terms of the general public, and well as important people, such as head of states and government officials. Due to bombings and premeditated attacks, the first line of defense is right at the boundary entrance, where a complex structural steel mesh prevents anything from being thrown in (to a certain level) but still allows visual access to the building and complex. The pedestrian will enter and must pass a security check point before entering the compound. At the main entrance the user is confronted with the receptionist and further security check if entering the upper levels of the building must be conducted. Vehicles entering the building will also be checked at each entrance.

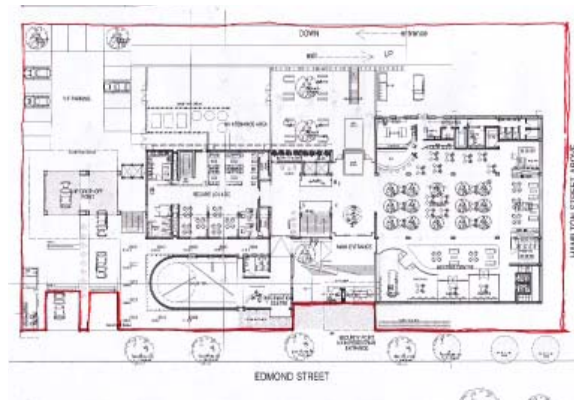

Fig.341: First line of defence, the boundary fence [Source: author]



Fig.342: different security zones in the building [Source: author]

## Façade treatment

The north and south façades are articulated in response to the sun. The southern façade is also presented at the entrance side of the building and should present the signage and flags of the European Commission.

## Links

Major physical links are located between the courtyard building and the new building. The smaller link is between the council chamber and the new building. These links are intended to be articulated in a light manner, contrasting to the existing cladding of the Agrivaal Building.

## Heating and Cooling system

The heating and cooling system uses trombe stacks that encourage the movement of air out of the building from the northern side of the building. Fresh treated air enters from the south side of the building. This process will be fully explained in the technical investigation.

## Ventilation system

The ventilation system works simultaneously with the heating and cooling system, and is the driving force of movement of heated or cooled air. The ventilation system also uses stacks located on the northern and southern façade, where solar energy heats the trombe stack encouraging movement of air from an area of high pressure to an area of low pressure. This process will be fully explained in the technical investigation.

Stacks had determined the facade articulation.

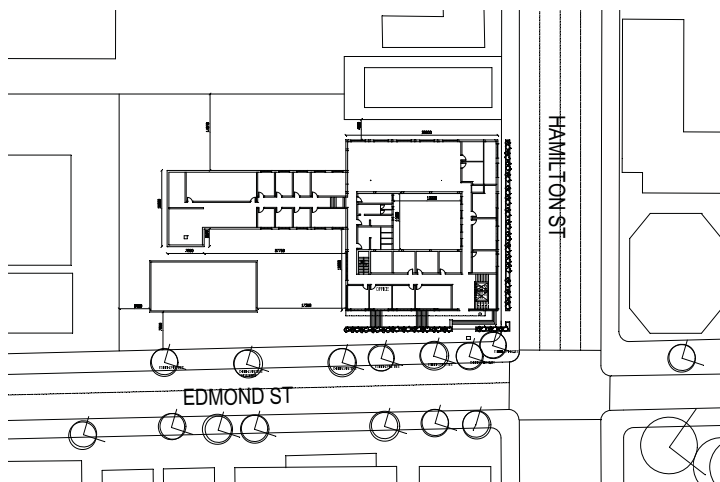

Fig.343:Existing plan of the Agrivaal Building

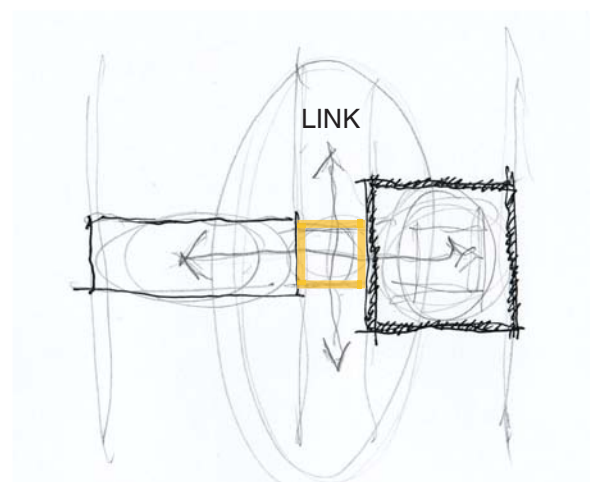

Fig.344:Parti diagram

# CONCEPT DEVELOPMENT

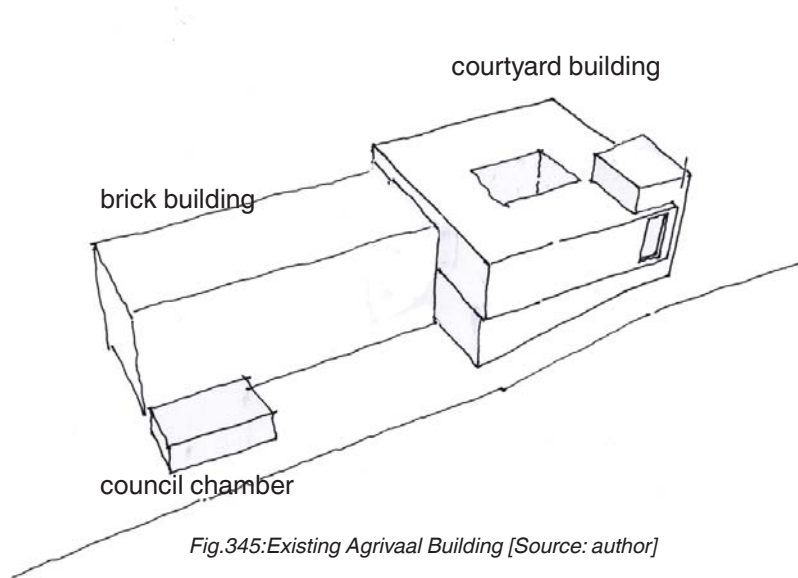

Fig.345:Existing Agrivaal Building [Source: author]

Identified as the 'new building' as existing facades to be stripped and slab and columns to be reused

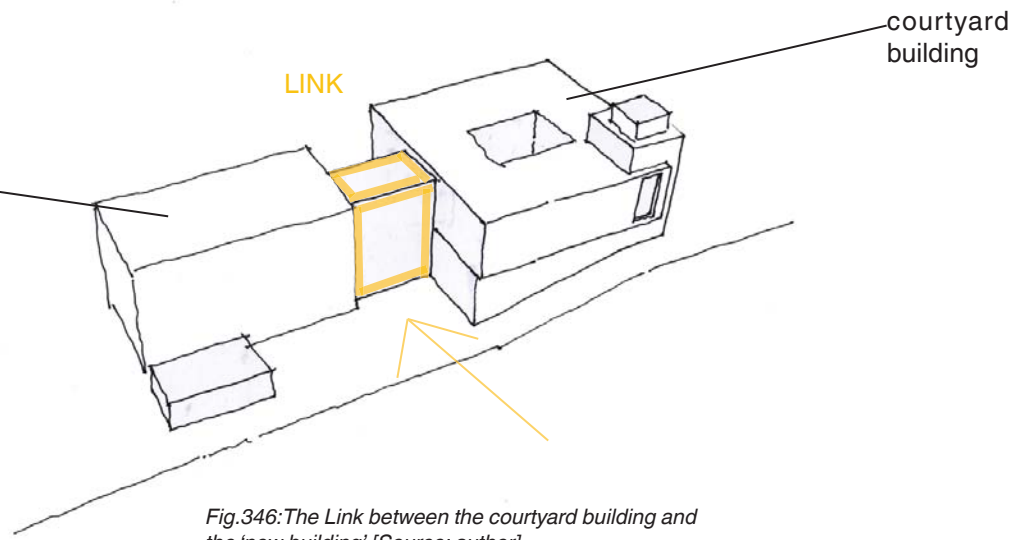

Fig.346:The Link between the courtyard building and the 'new building' [Source: author]

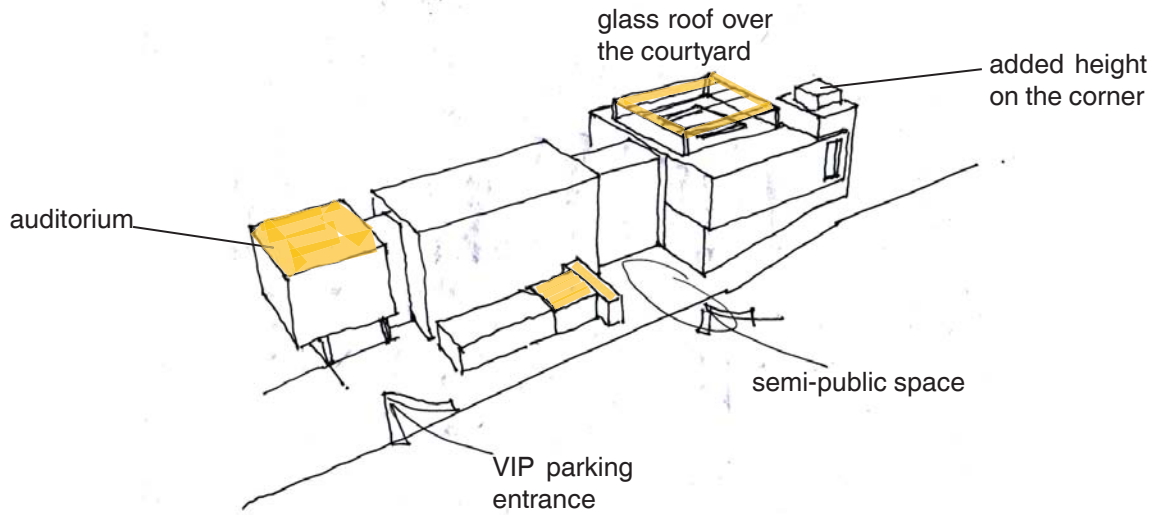

Fig.347: Auditorium and addition to council chamber [Source: author]

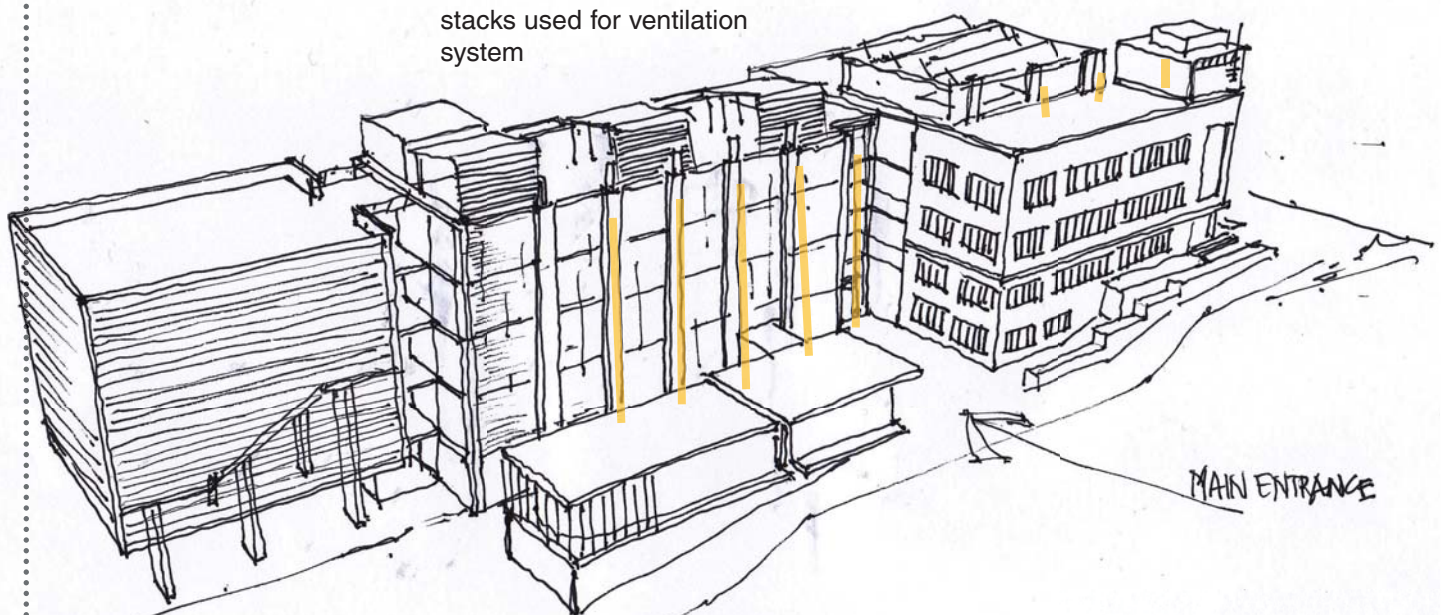

Fig.348: Proposed concept for Agrivaal Building [Source: author]



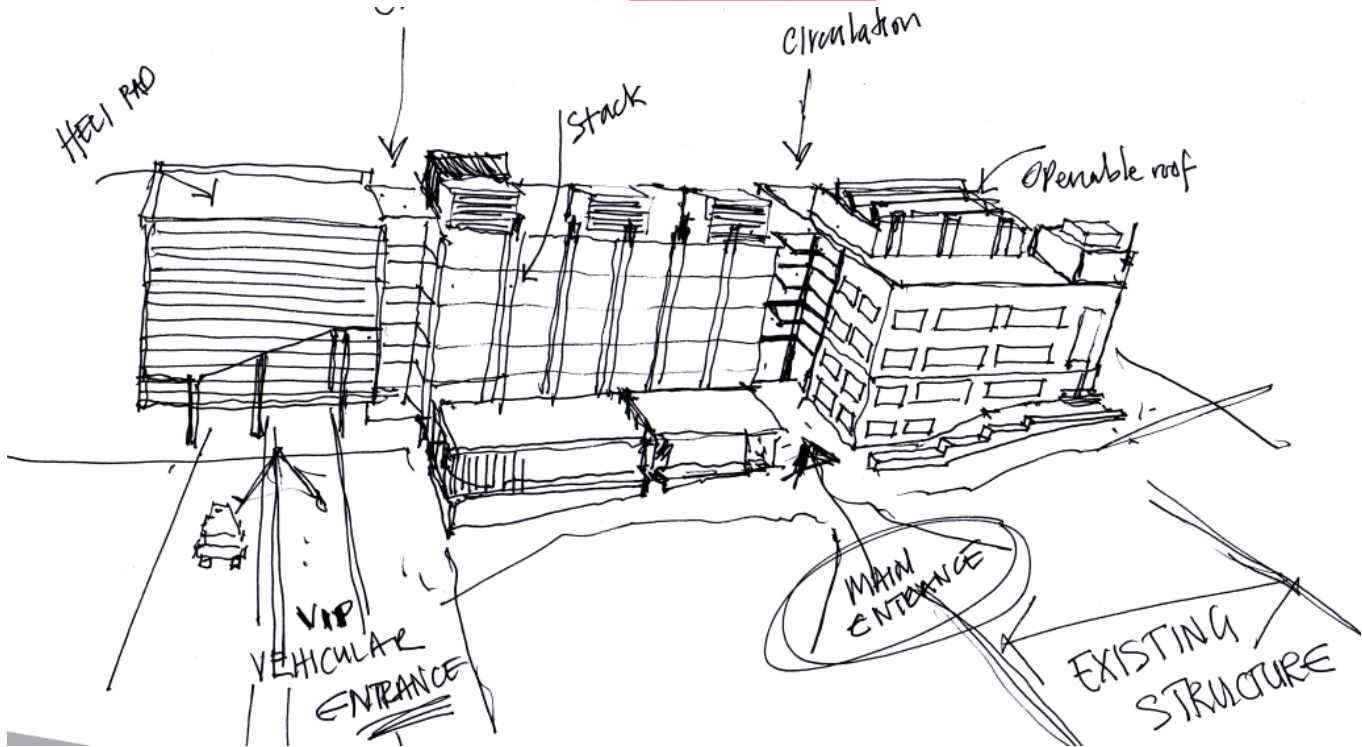

Fig.349: Design development [Source: author]



Fig.350: View of new southern facade [Source: author]

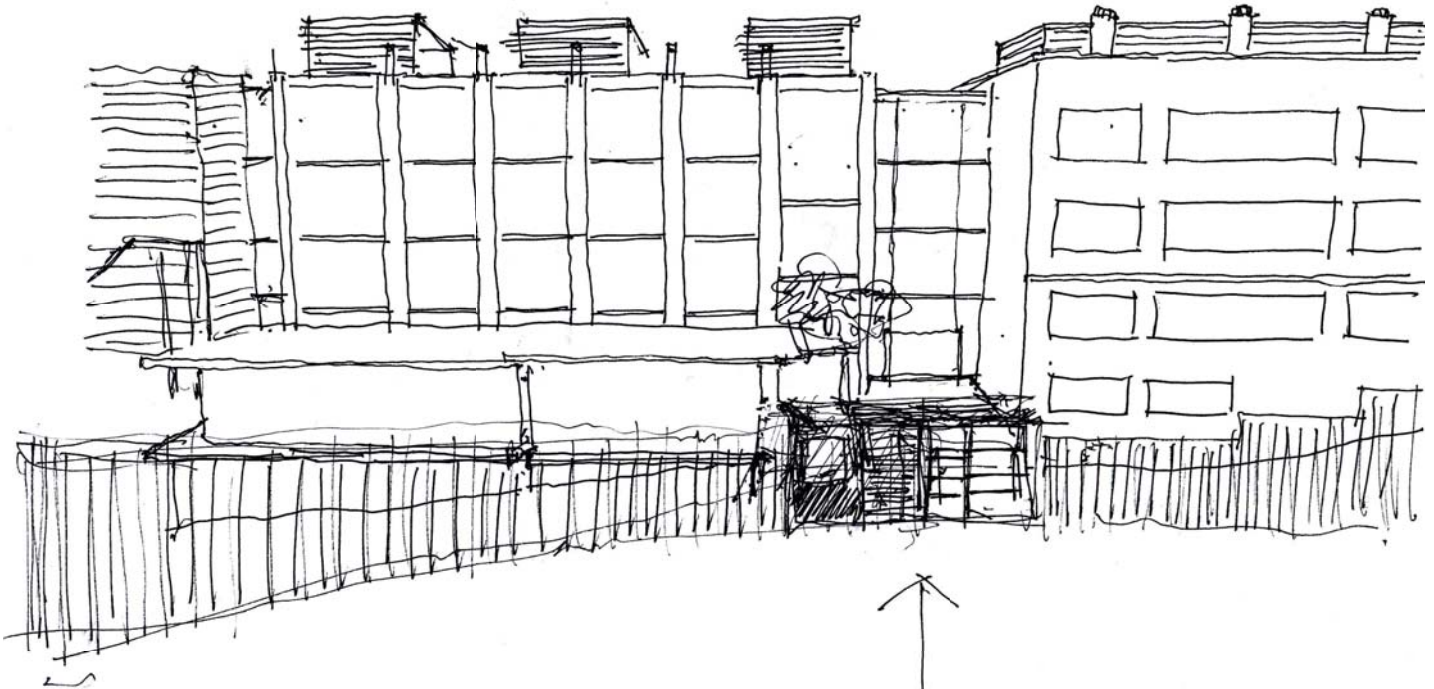

Fig.351: Sketch showing the concept of boundary fencing and entrance  
[Source: author]



Fig.352: Southern view of the proposed Agrivaal Building as seen on Edmond Street [Source: author]

# chapter 08

## technical investigation

---

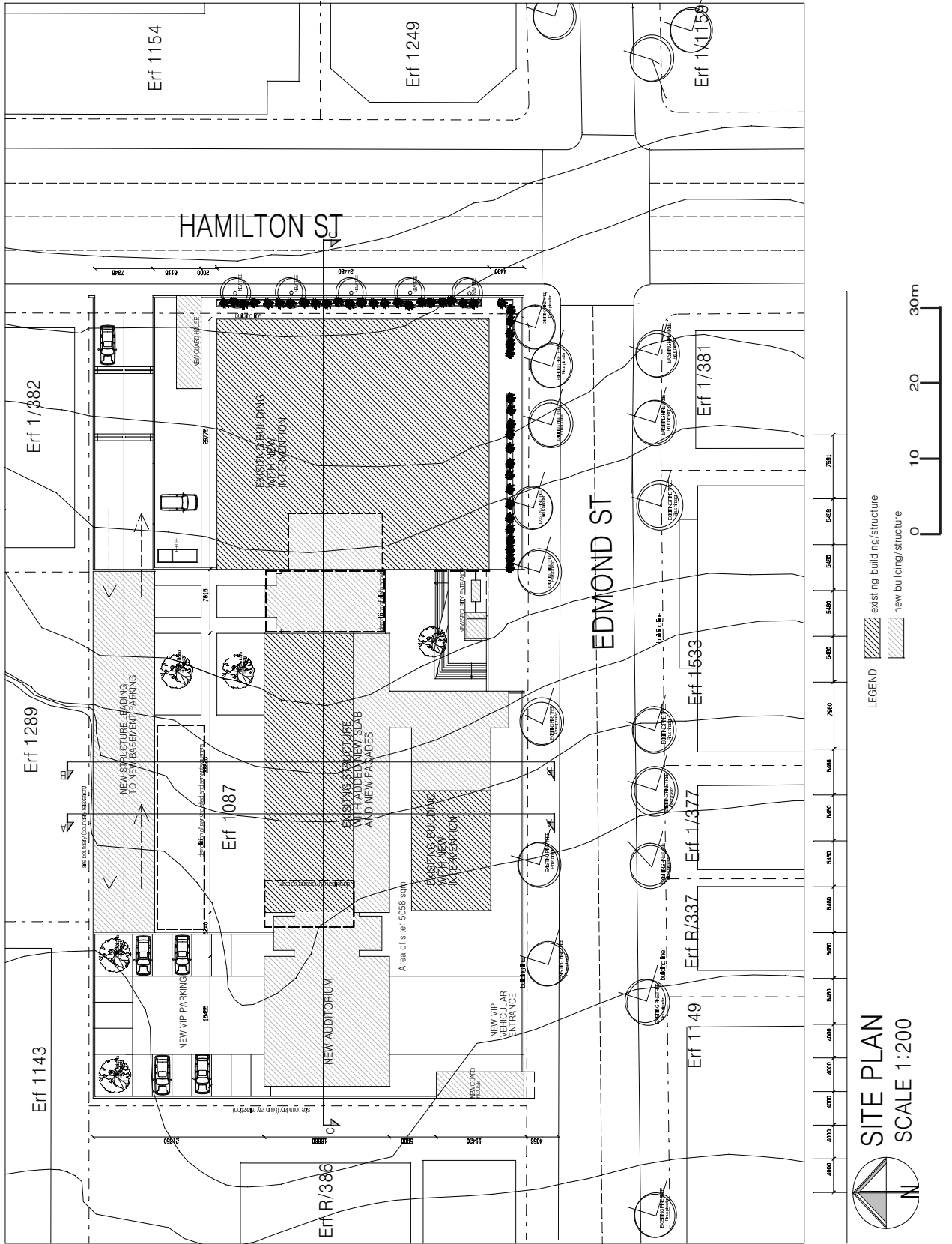

Fig. 353: Site Plan

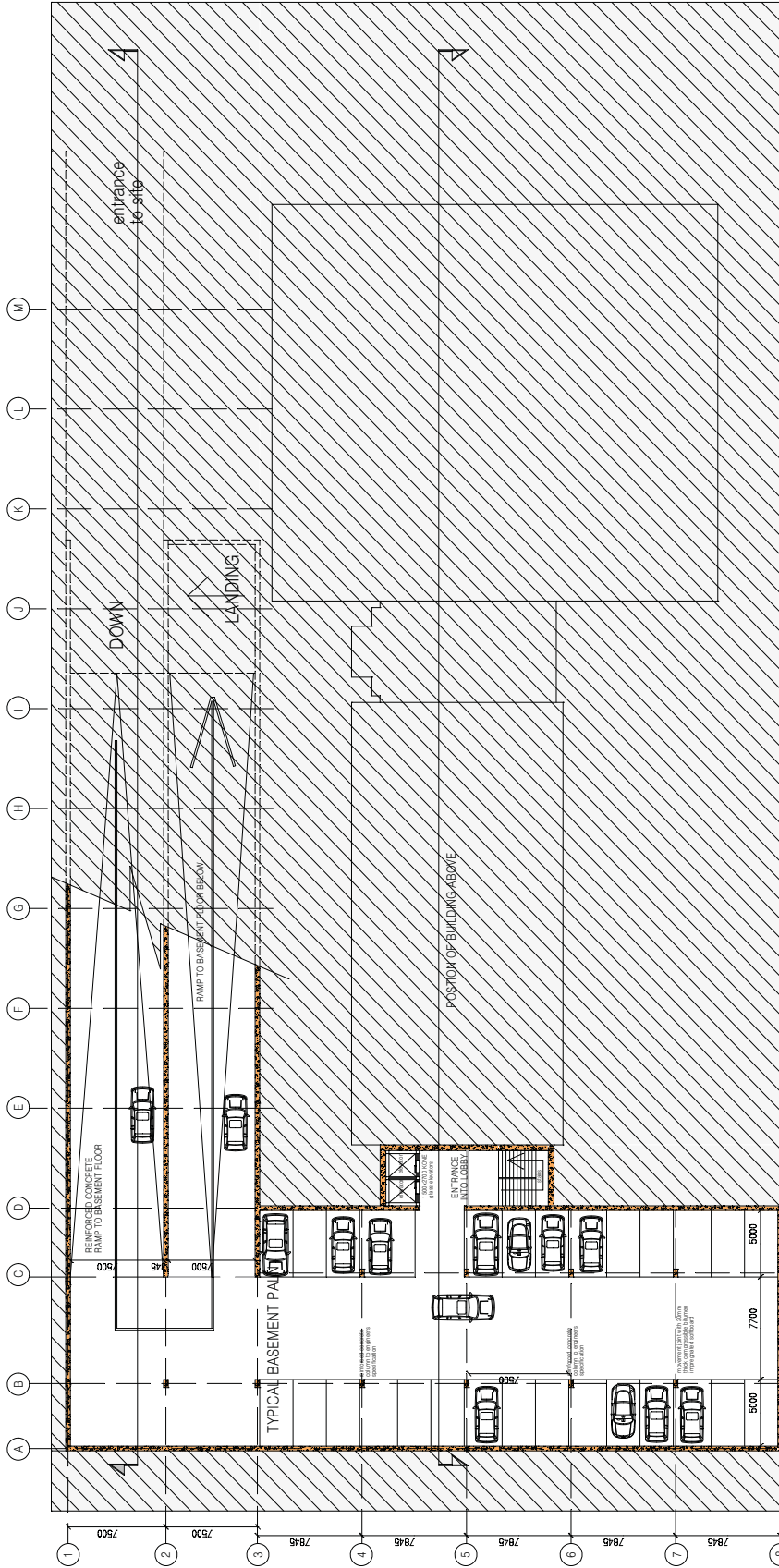
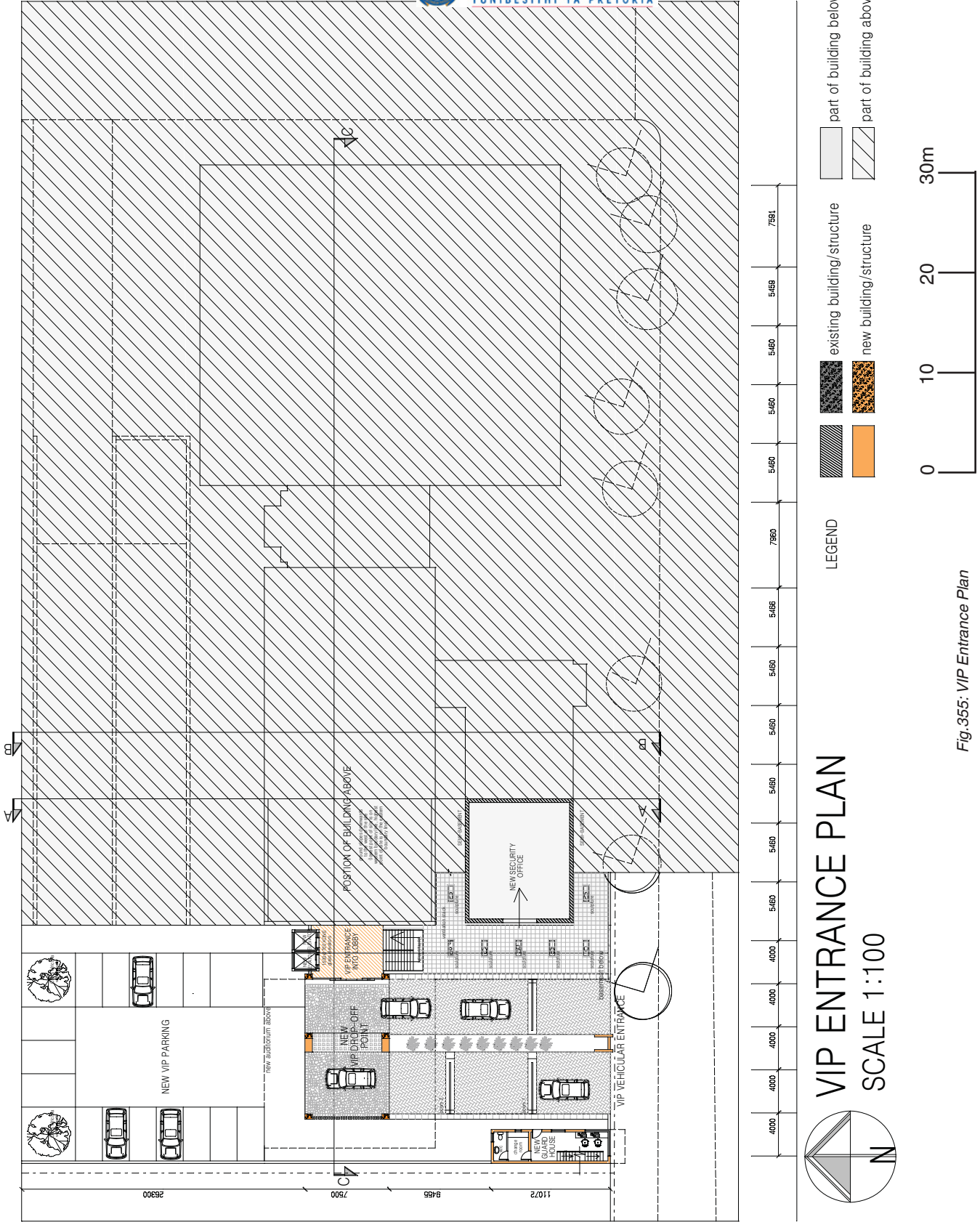

Fig. 354: Typical Basement Plan



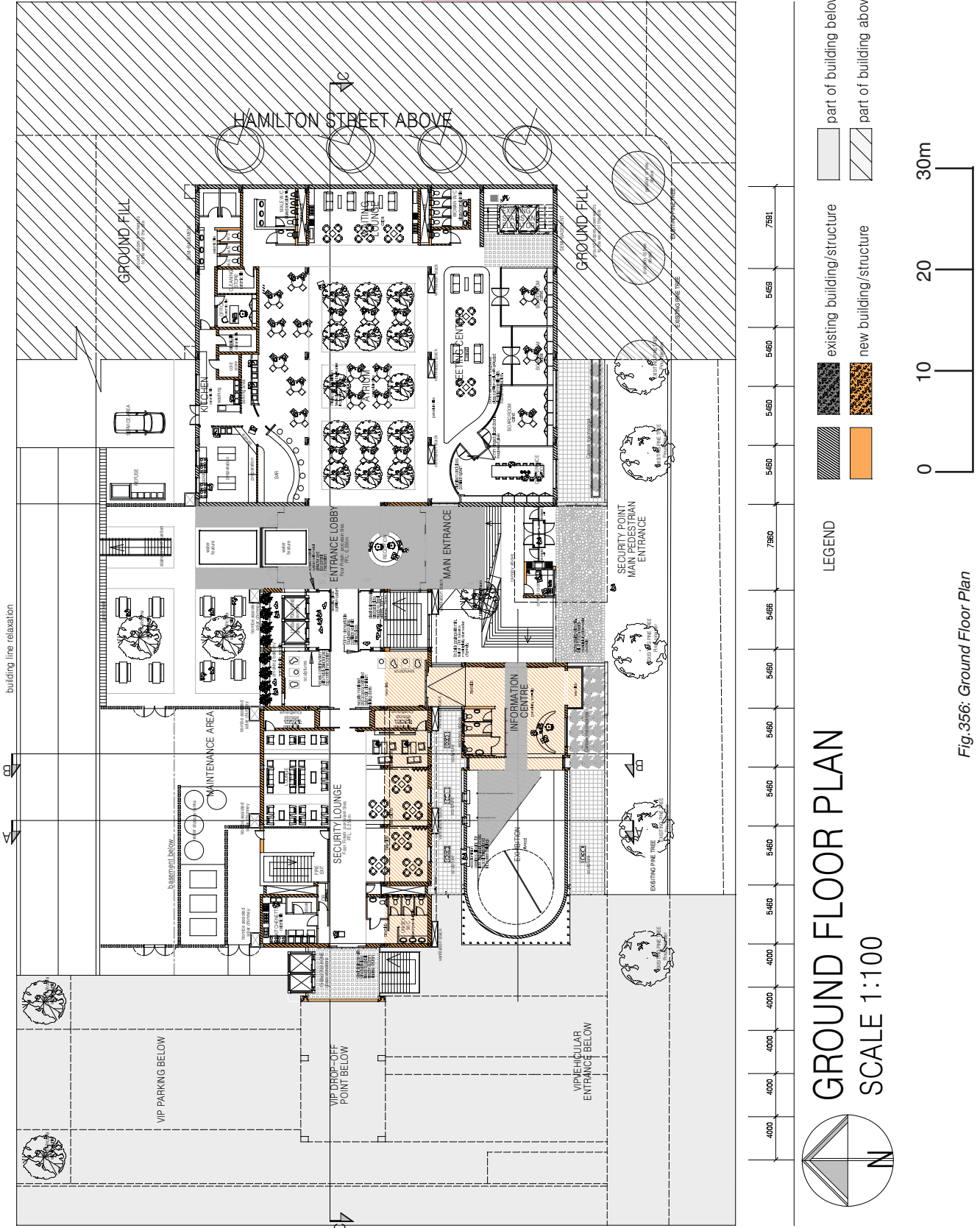

Fig.356: Ground Floor Plan





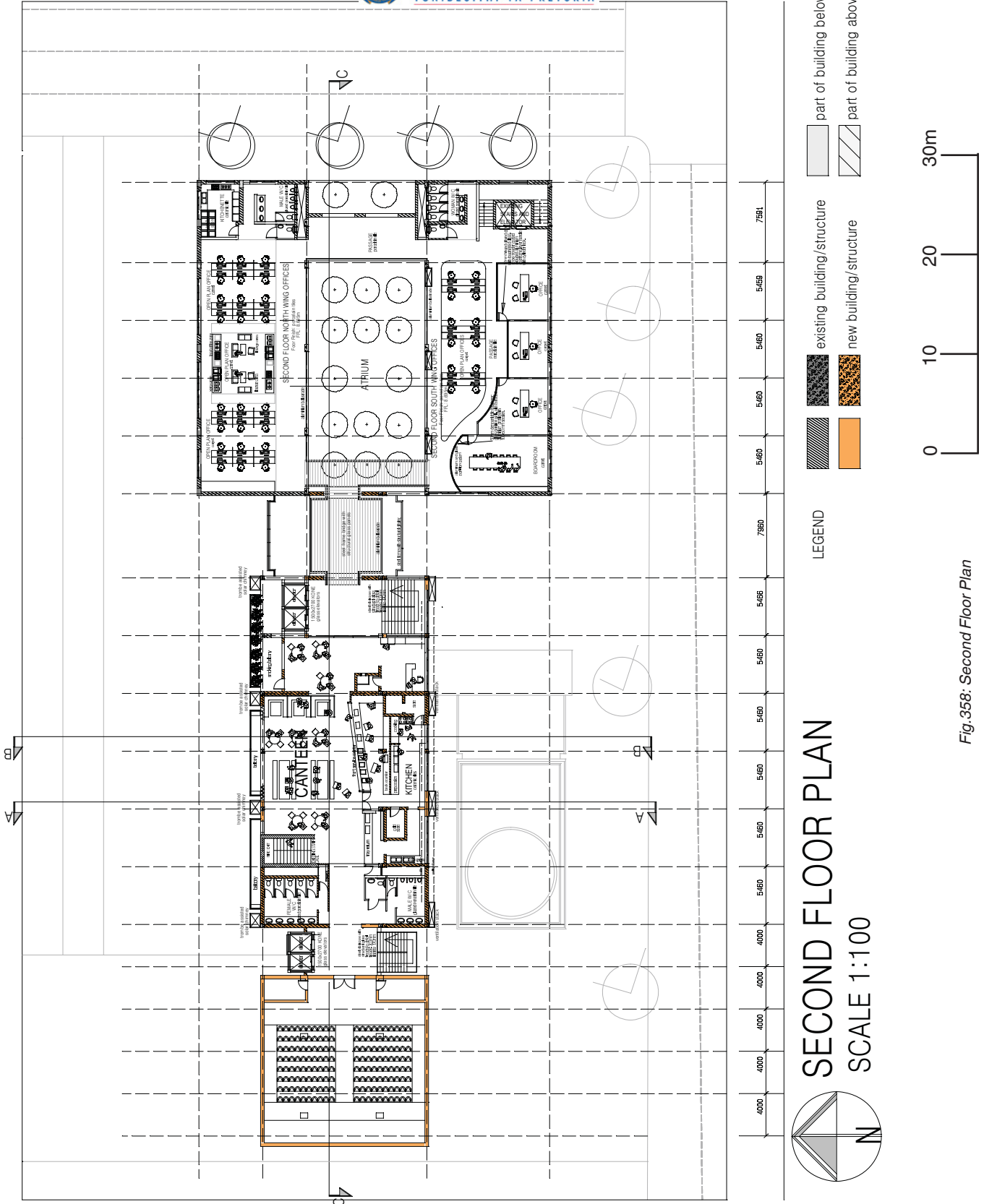

Fig.358: Second Floor Plan

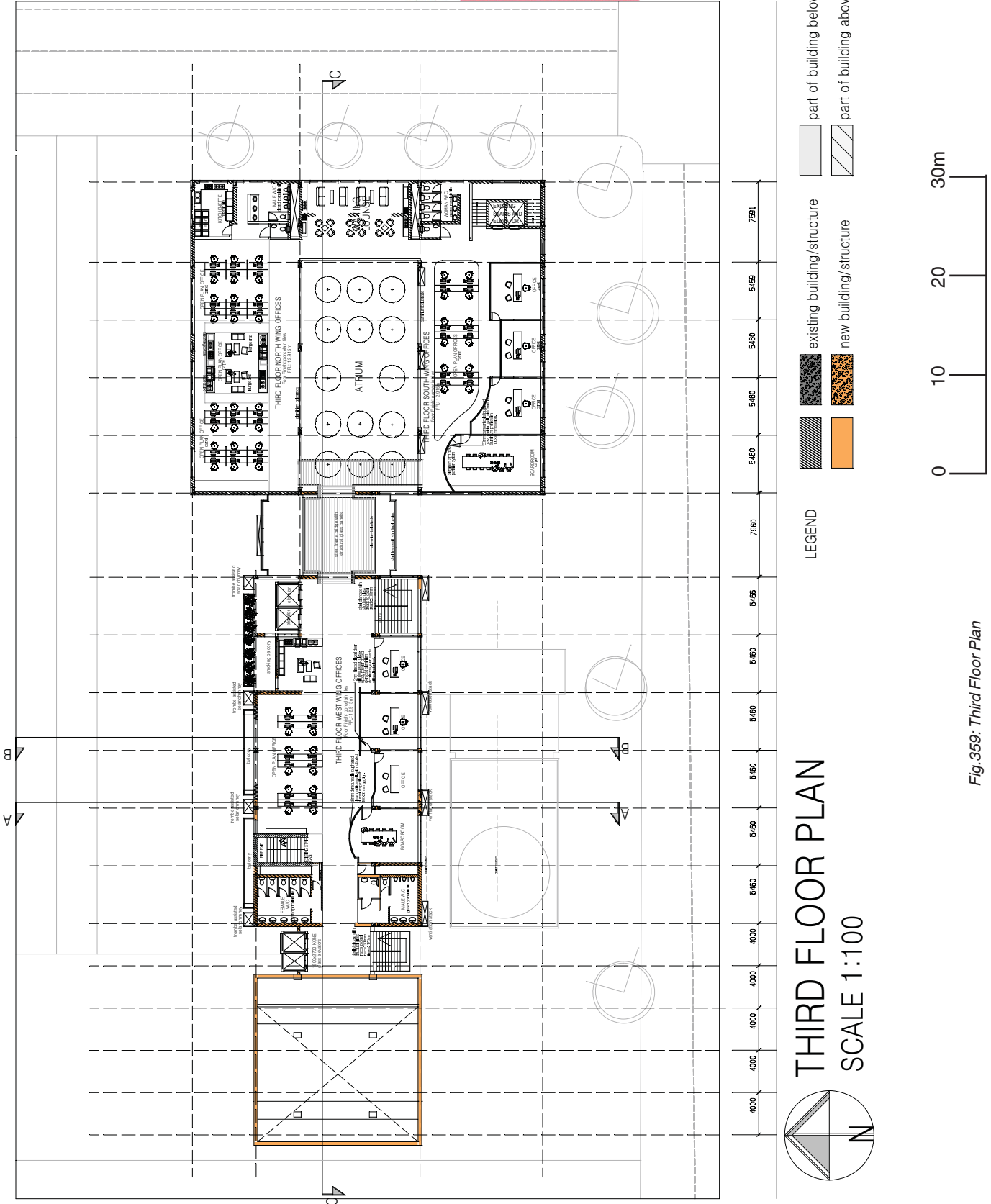

Fig.359: Third Floor Plan

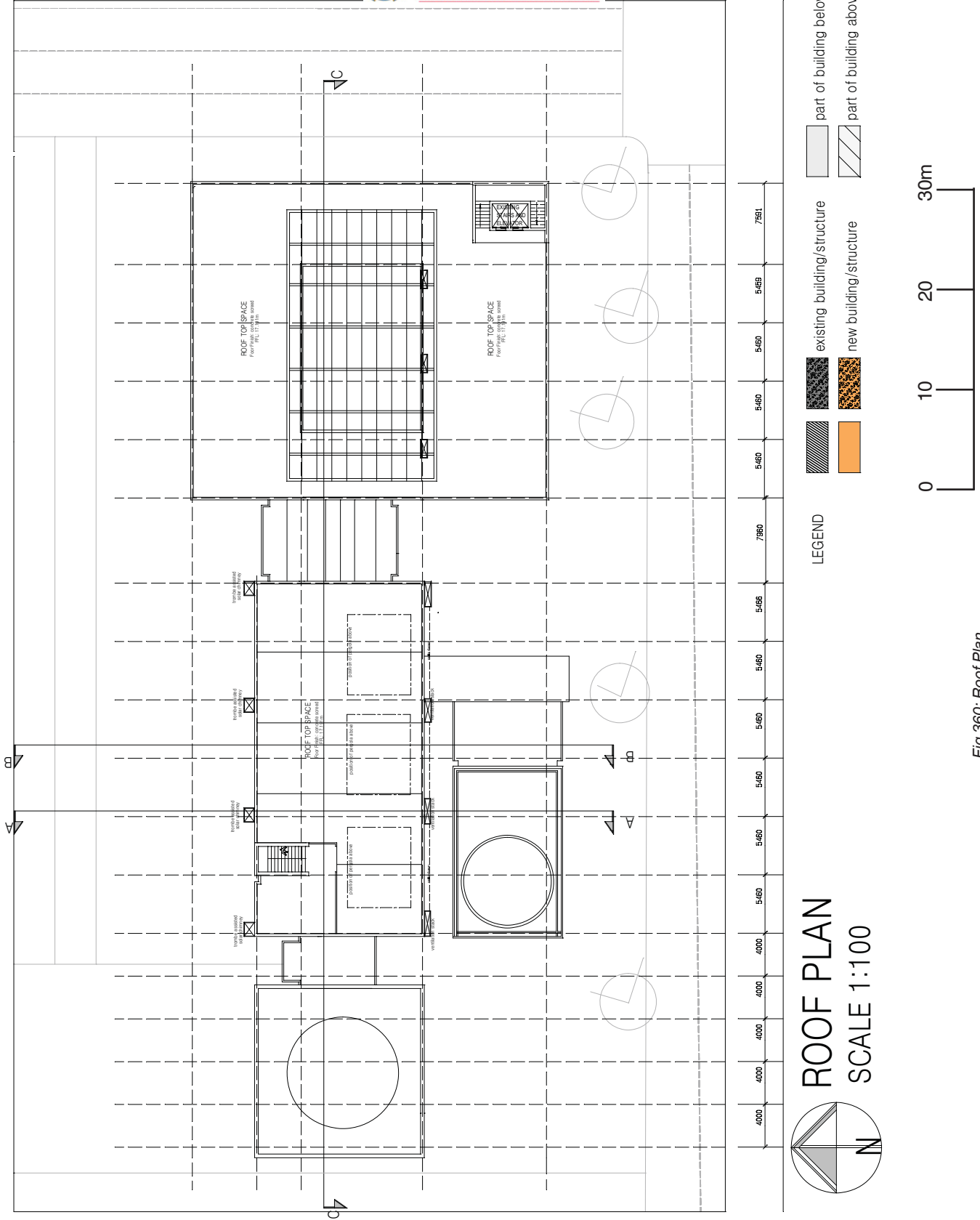

Fig.360: Roof Plan



Fig.361: Section A-A

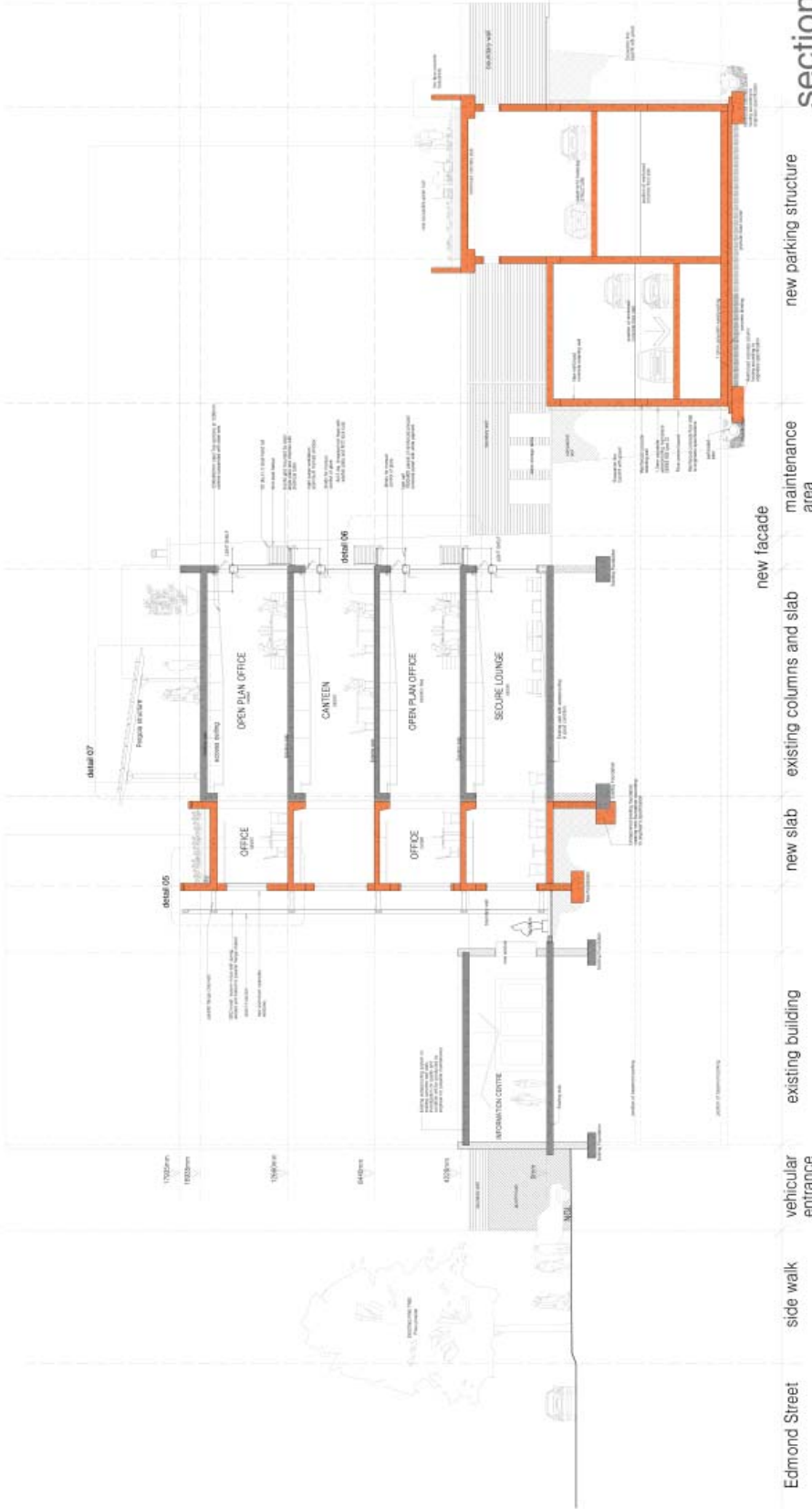

Fig.362: Section B-B



South Elevation

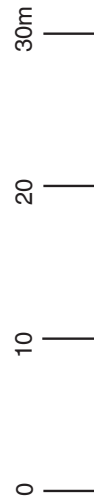
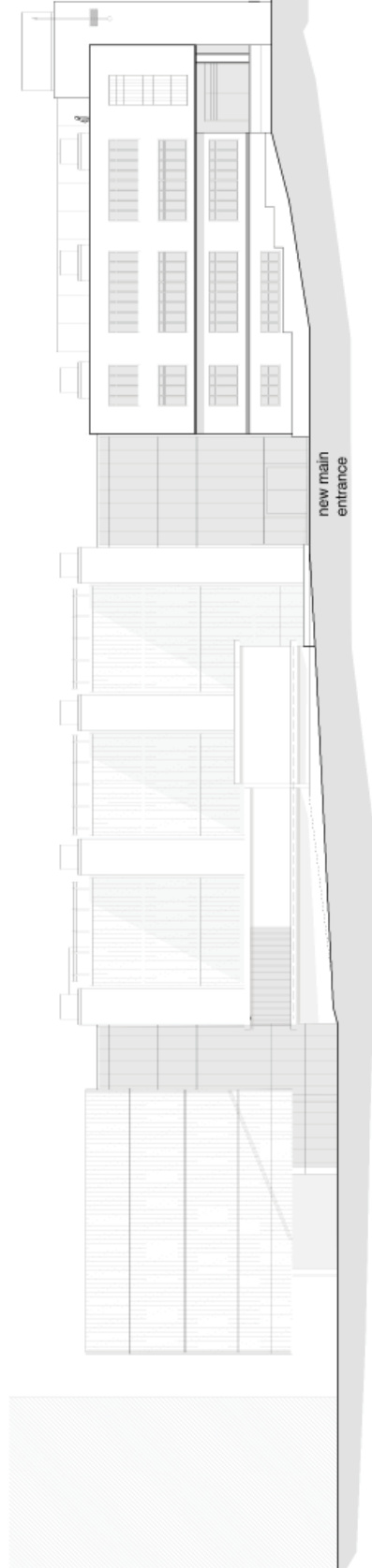

Fig. 363: South Elevation

# North Elevation

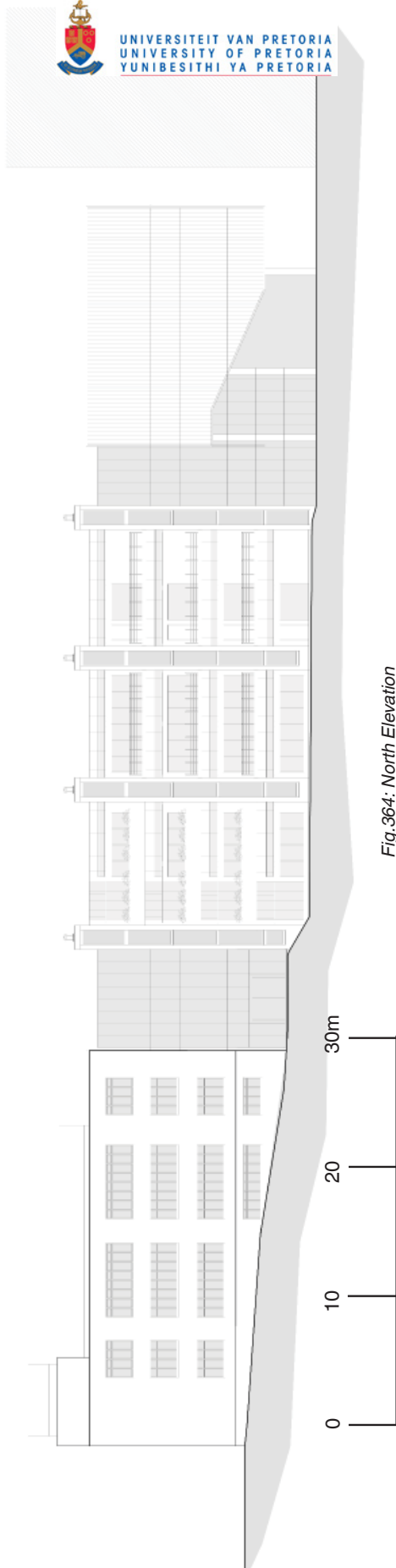

Fig.364: North Elevation

# \_technical investigation

## 8.1 STRUCTURE

The existing Agrivaal building comprises of concrete column and slab construction, indicative of Art Deco and early Modernism in South Africa. There are a number of grid systems used in the organisation of the building, as a result of many additions through the years. Large spans of space were achieved by the use of deep beams, some measuring up to 850mm. In the courtyard building (phase 1 and 2) 345 x 690mm rectangular reinforced concrete was utilised. Phase 3 extension has 345 x 345mm square reinforced concrete. Estimated slab thickness used throughout the existing building ranges from 255 to 300mm.

The new addition to the building mimics the structure in terms of material, however differs in detail. Subtle differences include the profile of beams, the finish of the concrete and the size of column utilised. The intention is to highlight the new structure, however in a manner that does not lose the integrity of the existing. Columns continue to respect the original grid system used by the architect of the Agrivaal.

The new vertical circulation utilised steel construction. The steel structure is placed between concrete masses for both circulation shafts. This contrast from the heavy and solid appearance of the existing Agrivaal Building. Steel columns consist of a rectangular hollow profile with two steel channels welded to opposite side (refer to fig. 299). The hollow profile provides rainwater downpipes. Each column will need new column footings.

Fig. 298 shows the added floor space and the auditorium as new structures.

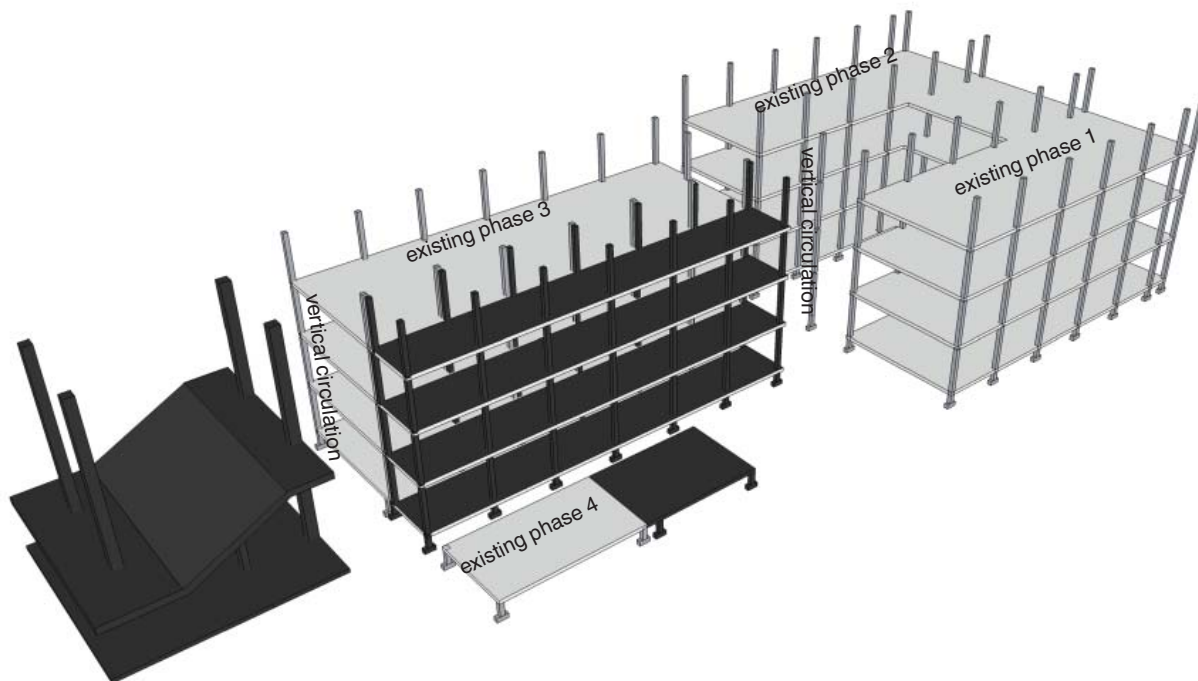

Fig.365:New and existing structure. [Source: author]



There are three primary structural additional to the building. They can be categorized as

- 1) addition of floor space on phase 3
- 2) vertical circulation at two points along the building (stairs and elevators)
- 3) addition to the information centre
- 4) new auditorium



Fig.366: New and existing structure

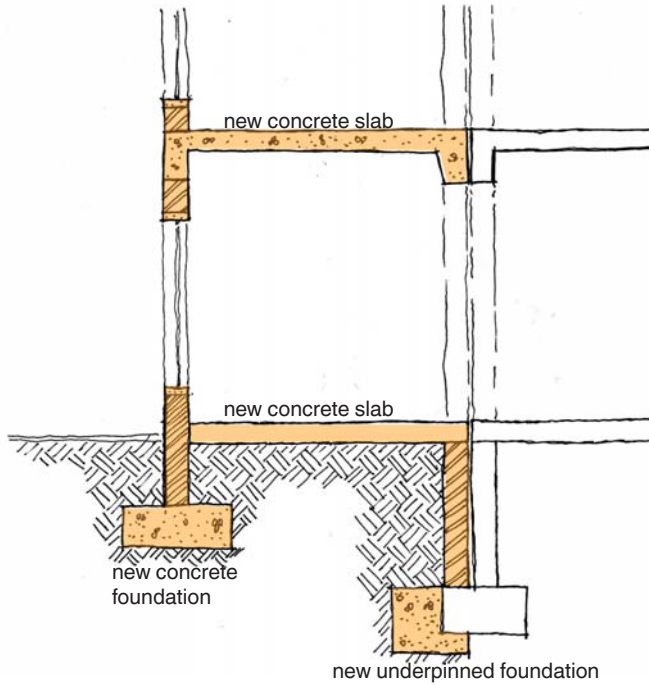

Fig.367: New concrete structure [Source: author]

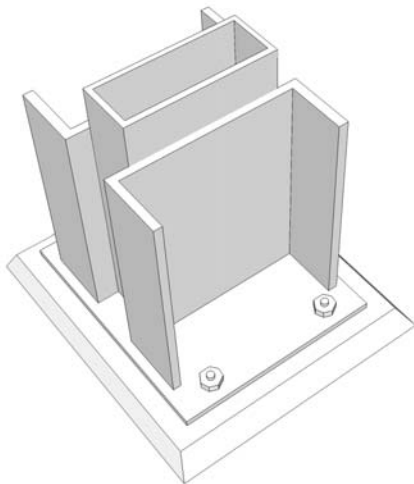

Fig.368: Steel column, rectangular hollow profile with two steel channels welded to opposite sides. [Source: author]

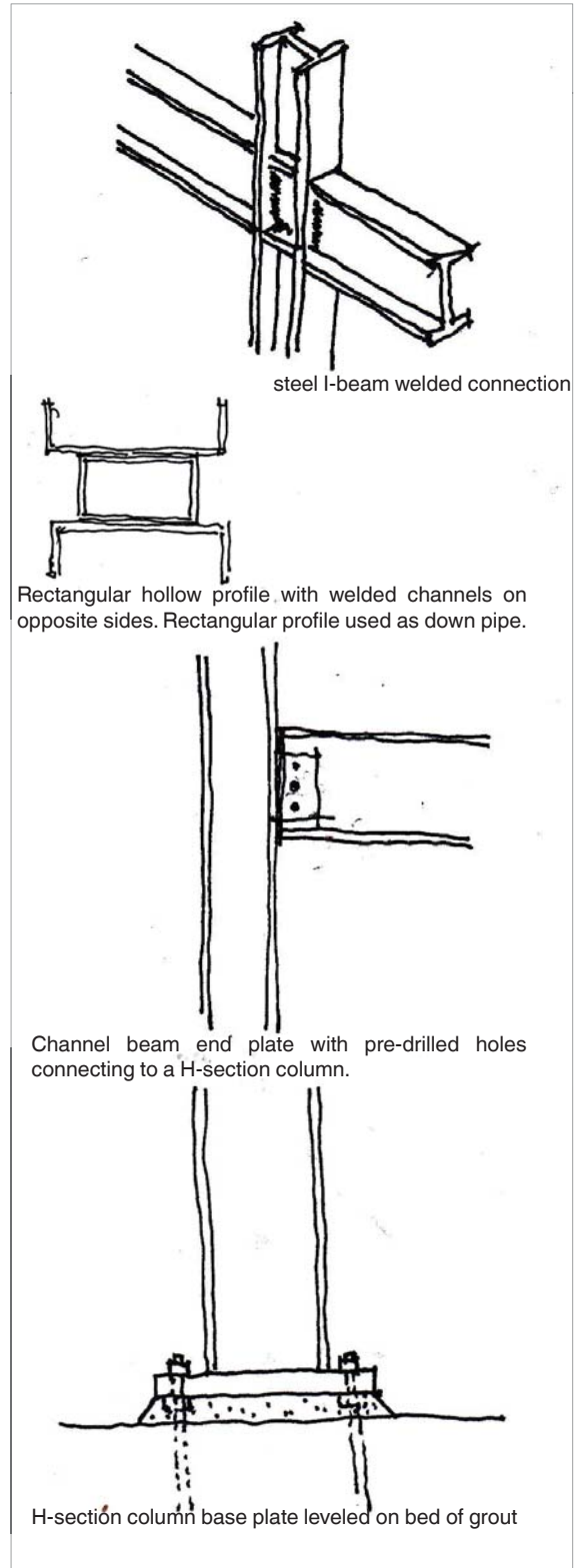

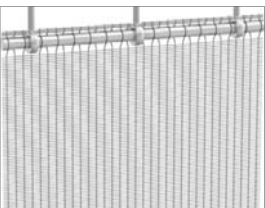



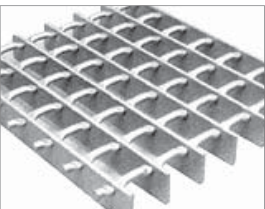
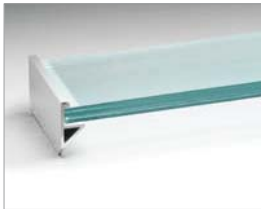







Fig.369: CONCEPT sketches of steel details, drawings not to scale. [Source: author]

## 8.2 MATERIAL STRATEGY

Material choice for a building that will be used on a daily basis, including areas for public use, must be durable and have easy cleaning qualities. Materials chosen were either to complement and in some cases completely contrast the existing materials. Housing the Delegation of the European Union, the building intends to reflect an appearance of transparency, integration and high-technology while respectful to nature. Other issues influencing material choice included security, respect for cultural heritage, and sustainability.

Existing Materials	Proposed Materials			
	Metals	Glass	Timber	Concrete
 <p data-bbox="170 833 435 866"><i>Fig.370: Terrazzo Cladding</i></p>	 <p data-bbox="479 841 743 866"><i>Fig.374: GKD mesh</i></p>	 <p data-bbox="755 841 1015 866"><i>Fig.378: Safety glass</i></p>	 <p data-bbox="1031 841 1299 866"><i>Fig.381: Timber flooring</i></p>	 <p data-bbox="1315 841 1575 866"><i>Fig.383: Concrete</i></p>
 <p data-bbox="170 1119 435 1142"><i>Fig.371: Clay Bricks</i></p>	 <p data-bbox="479 1119 743 1142"><i>Fig.375: Mentis Grid</i></p>	 <p data-bbox="755 1119 1015 1142"><i>Fig.379: Laminated glass</i></p>	 <p data-bbox="1031 1119 1299 1142"><i>Fig.382: Reused parquet flooring</i></p>	
 <p data-bbox="170 1386 435 1408"><i>Fig.372: Existing Parquet Flooring</i></p>	 <p data-bbox="479 1386 743 1408"><i>Fig.376: Steel</i></p>	 <p data-bbox="755 1386 1015 1408"><i>Fig.380: Toughened glass</i></p>		
 <p data-bbox="170 1652 435 1675"><i>Fig.373: Steel railing</i></p>	 <p data-bbox="479 1652 743 1675"><i>Fig.377: Stainless steel cables</i></p>			



## Metals

### Steel

Steel will be used as the primary load bearing structure material for the vertical circulation, and for the secondary structure as façade screen.

Steel columns are needed to support the new vertical circulation shafts, located at the main entrance and to the east of the new auditorium. These columns will be painted with fire retardant paint.

**Heritage:** Steel is utilised as it is a structural material that can be disassembled from the existing building. This is in accordance with the Burra charter.

**Sustainability:** According to the South African Institute of Steel Construction (2011), Steel has a number of advantages which include: “low waste, flexibility, offsite manufacture, speed, resource efficiency, adaptability, demountability, long lasting appeal, safety, reusability and recyclability. These inherent characteristics result in many social, environmental and economic benefits to satisfy sustainability’s “triple bottom line””.

**Old and new:** The use of steel for the vertical circulation and the screen system in the southern façade is intended to contrast the appearance of the solid, heavy terrazzo in the existing courtyard building. A clear distinction in material choice and articulation of both these elements in the design emphasises that they are new.

## Other Metals

### GKD mesh

GKD mesh is utilised on the southern façade as a protective layer, on what would have been a façade articulated with glass. Possible bomb threats are part of the security design considerations. The façade is also parallel to Edmond street, where the new main entrance to the building is located. The screen acts as a unifying element from the auditorium to the main entrance of the building.

### Mentis grid

Mentis grid is used mainly on the northern façade on balconies that are new additions to the existing structure.

## Timber

Offices in the existing Agrivaal Building consists of parquet teak flooring. Some of the material has been damaged or stolen. However there is a large amount of the parquet available to be reused.

Many of the offices have good condition teak cupboards, door frames and decorative wall framing. Apart from the vandalized material, many can be recycled and used for flooring, paneling or furniture.

In the proposed design, timber is used as partition systems, demarcating different zones of security and/or privacy. Timber is also used as a floor finish to highlight areas of prescribed use, such as waiting areas, walkways etc.

All timber used will have the South African Bureau of Standards (SABS) seal of approval.

**Heritage:** Existing timber will be reused throughout the building. The existing timber does not have high heritage value however, it is part of the original material palette, and thus contributes to memory of the space.

**Sustainability:** Existing teak timber on site will be reused. Any new timber used will be sourced locally from a certified sustainable forest.

**Old and new:** The existing teak timber had a deep dark colour, which will be maintained. New timber used will be a lighter shade, creating a contrast between the existing and the new.



## Glass

Glass is used to contrast the solid heavy appearance of the existing Agrivaal Building. The glass and steel articulation provides light and transparent links at certain parts of the building which is experienced visually from outside the building. When inside the building, clear distinction of the new is experienced by being completely surrounded with glass, natural light and exposure to the exterior.

Safety glass is utilised in the building as it provides strength and thus safety for use in high activity areas such as stair cases, elevators and large glass openings. Safety glass used include toughened glass, and toughened laminated glass.

Glass applications include the staircase, elevator shaft, partition systems and large window openings.

All glazing type and fixing will adhere to the SABS, The application of the National Building Regulations (NBR), Part N on glazing. Indicating guidelines on safety, waterproofing, awareness of glass around people, position of glazing, requirements on fixing and material choice.

**Heritage:** Glass allows the transparency and visual link to the existing building. Where steel structure and glass infill provide for the 'link' between the **old and new** structures, it is executed in a manner that lightly touches the existing and appears to be temporary.

**Sustainability:** Glass is a recyclable material. It provides a visual and physical connection to the outdoors. Windows can be opened or closed to manipulate indoor air quality and comfort, including ventilation, keeping heat in or out.

## 8.3 SYSTEMS - VENTILATION, HEATING AND COOLING SYSTEM

### 7.3.1 Ventilation

Ventilation in the Agrivaal Building will make use of trombé assisted solar chimneys on the northern façade. The southern façade of the building will have stacks, used for introducing new air into the building. Stacks on the southern façade are composed of masonry 230mm walls with openings to each floor, and a whirlybird at the top of the shaft to encourage air movement. The northern trombé assisted solar chimneys will have glass panels facing the northern sun. This allows solar energy to accumulate in the chimney creating pressure and thus an upward movement in the stack.

The ventilation system works on the following principles refer to Fig. 317:

- Air moves from an area of high air pressure to an area of low pressure.
- Warm air in the room rises and accumulates at the ceiling. The slanted ceiling encourages the movement of air towards an opening leading to the stack.
- The trombé assisted solar chimney has been heated due to the accumulation of longwave radiation from the solar energy exposure on to the glass panel. This has caused negative pressure in the stack. This also encourages the movement of air from the room towards the opening of the trombé stack.
- Heated air moves upwards, which is speeded up by the narrowing of the stack. The building's masonry layer is insulated on the interior side, limiting heat transfer into the building.
- When air is channeled into a constricted opening, its speed increases (venturi effect).
- The air exists the chimney.
- Due to the negative pressure on the north side of the building, the southern side experiences displaced air, thus sucking in air from the southern façade stack.

### 7.3.2 Heating and Cooling

The heating and cooling of the building is dependant on the principles of the ventilation system. The ventilation system delivers the heated or cooled air to the intended space. This system was designed after consultation with Vosloo (2011).

The air drawn in from the atmosphere on the southern façade (due to suction, since warm air escaped from the chimney on the northern façade), will pass through a heated or cooled radiator resulting in the users required temperature for the space occupied.

Thus, the goal is to attain a heated 'liquid' to pass through the radiators to achieve warm air. For cool air, cold 'liquid' is needed to circulate in the radiators.

For cool air :

The concept used to achieve the cooling of a 'liquid' such as anti-freeze liquid or glycol is evaporative cooling.

The stack located on the southern façade is separated into two separate ducts (refer to Fig. 324). Duct A is where the evaporative cooling will take place. Duct B is where the air will pass through the cool radiator to achieve cool air.

Both ducts have large radiators positioned at the top of the stack, where air enters from the atmosphere. In duct A water is sprayed onto the radiator where by evaporative cooling lowers the temperature of the glycol. The excess water is collected and recycled into a water system. The cool glycol from stack A is pumped into the second stack B to circulate in the large radiator, which can now cool the air that moves through it (refer to Fig. 325). Smaller radiators are positioned before the entrance of the opening leading into level of the building to further cool the air if needed.

For warm air :

The concept used to achieve the heating of a 'liquid' such as glycol or oil is through solar energy utilising a parabolic heat collector.

For heated air into the building, hot liquid from a parabolic heat collector positioned on the roof is circulated into the radiator (refer to Fig. 322 and 323). Air from the atmosphere passes through the radiator, warming the air intended for the interior space. The movement of air is dependant on the ventilation system, specifically the displacement of air from the northern stacks causing suction in the southern stacks. The southern stack narrow towards the bottom, encouraging the movement of air. Funnels aid in directing air into openings to the interior spaces.

The parabolic heat collector uses solar energy to concentrate the sun's energy onto a focal point where heat transfer liquid (usually oil) is positioned. When the liquid is heated it is pumped into an insulated storage tank ready for use.

# Ventilation

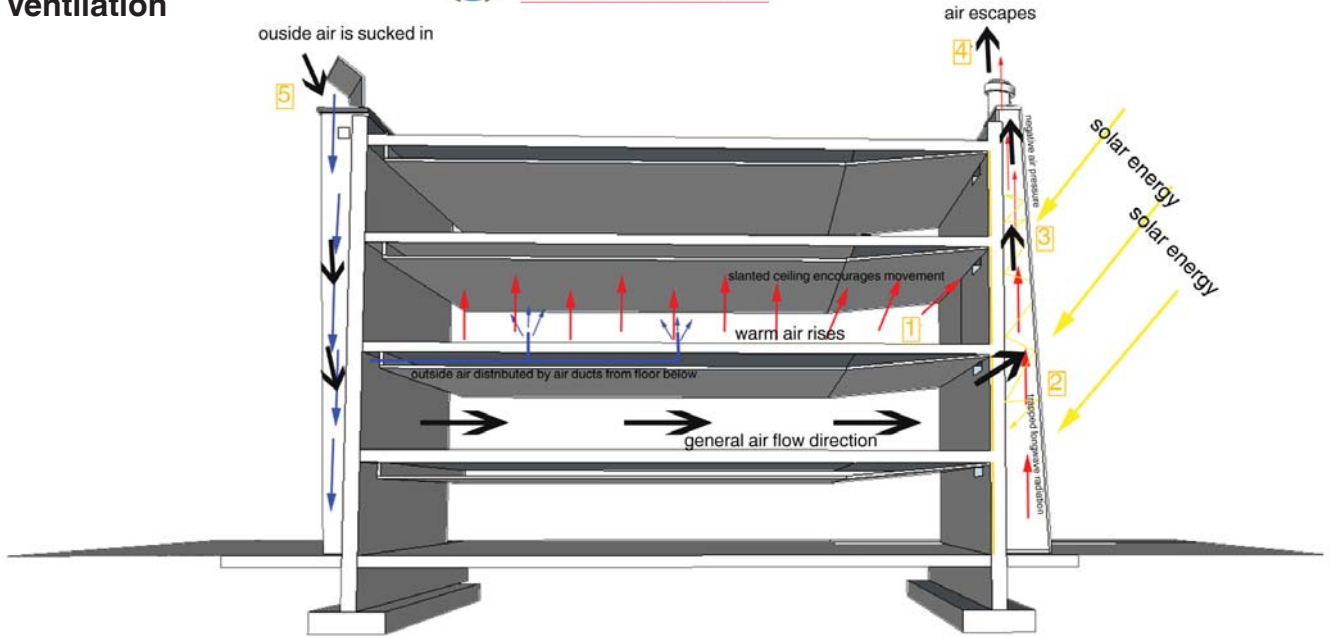

Fig.384: Ventilation system. [Source: author]

## Ventilation Concept

- ventilation →
- 1 Warm air in the room rises and accumulates at the ceiling.
  - 2 The trombé assisted solar chimney has been heated due to the accumulation of longwave radiation from the solar energy exposure on to the glass panel. This has cause negative pressure in the stack.
  - 3 Heated air moves upwards, which is speeded up by the narrowing of the stack. The building's masonry layer is insulated on the interior side, limiting heat transfer into the building.
  - 4 The air exists the solar chimney.
  - 5 Due to the negative pressure on the north side of the building, the southern side experiences displaced air, thus sucking in air from the southern façade stack.

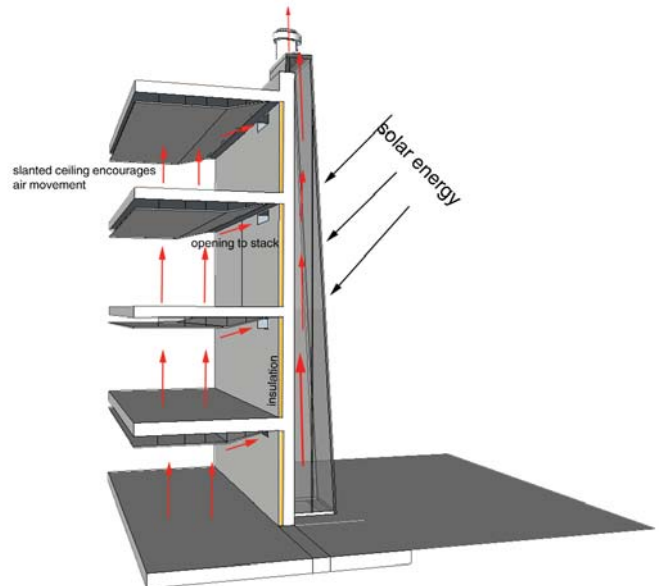
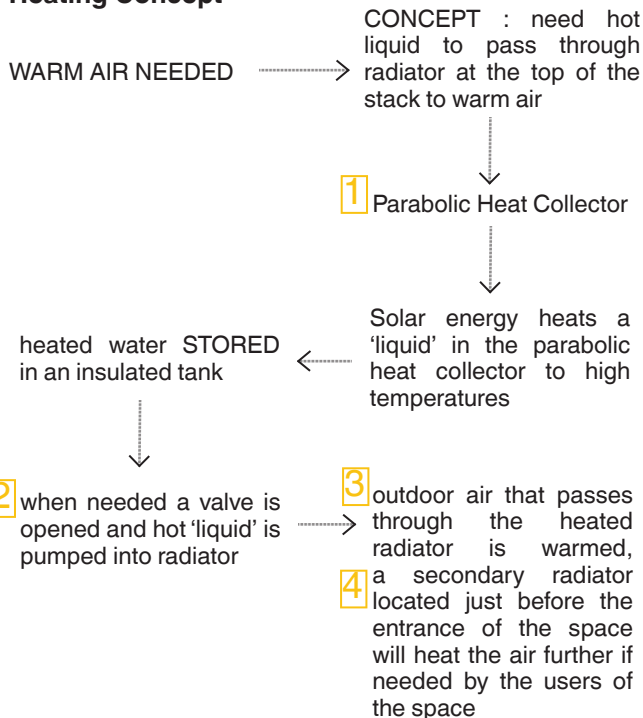

Fig.385: Trombe assisted solar chimney . [Source: author]

## Heating and Cooling

$$\begin{array}{ccccc}
 \text{VENTILATION} & & \text{WARM AIR} & & \text{CONDITIONED} \\
 \text{SYSTEM} & + & \text{or} & = & \text{ROOM} \\
 & & \text{COOL AIR} & & \\
 \text{[delivery system]} & & \text{[conditioned air]} & & \text{[conditioned room]}
 \end{array}$$

### Heating Concept



### Warm air

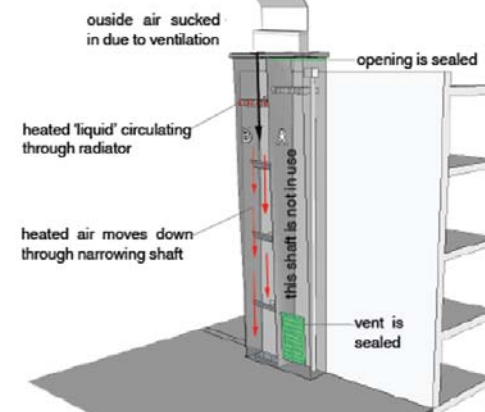

Fig.387: Warm air production, internal workings of stack, front view. [Source: author]

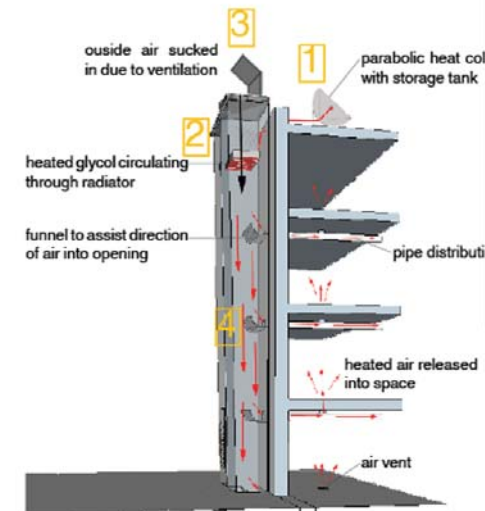

Fig.388: Warm air production, internal workings of stack connected to parabolic heat collector, side view [Source: author]



**Heritage:** The ventilation and heating/cooling system utilise are masonry structures that can demolished from the structure without damaging the existing structure or facade. Openings for air movement between shaft and room can be closed and plastered back to match original building material.

**Sustainability:** The ventilation and heating/cooling system tries to be passive systems. The exception includes pumps that rely on electricity. Areas such as the auditorium use a monitored air conditioning system.

**Old and new:** The stacks used for ventilation and heating/cooling system are repetitive elements on the new north and south façades. On the courtyard building façade (south), the terrazzo cladding takes importance and thus the stacks are placed inside the building, protruding out of the concrete roof. New architectural language informed by the ventilation and heating/cooling system provides character to the proposed design.

### Cooling Concept

COOL AIR NEEDED

CONCEPT : need cool liquid to pass through radiator at the top of the stack to cool air

Evaporative Cooling

**2** stack A: radiator will be circulating glycol in it, which has high thermal capacity. Air from outside stack will pass through the radiator while water is sprayed onto the radiator. This will cool glycol.

**1** The stack will be divided into two sections.

**3** stack B: cool glycol is transferred from stack A to stack B's radiator. Air from outside passes through radiator in stack B. This produced cool air.

**4** a secondary radiator located just before entrance of the space will also receive cooled glycol, where the cool air in stack B can further be cooled if needed by the users of the space

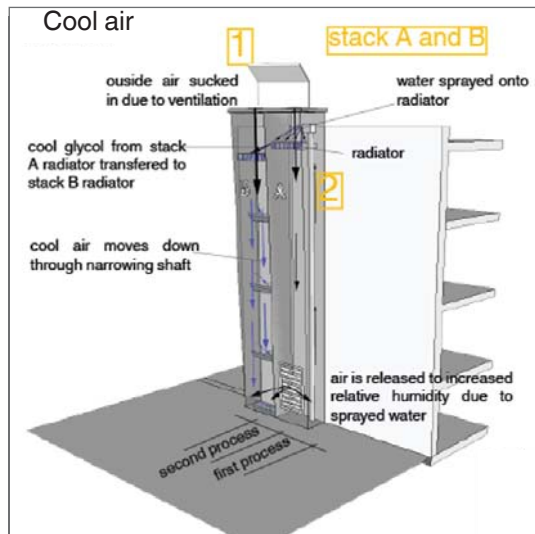

Fig.389: Cool air production, internal workings of stack front view. [Source: author]

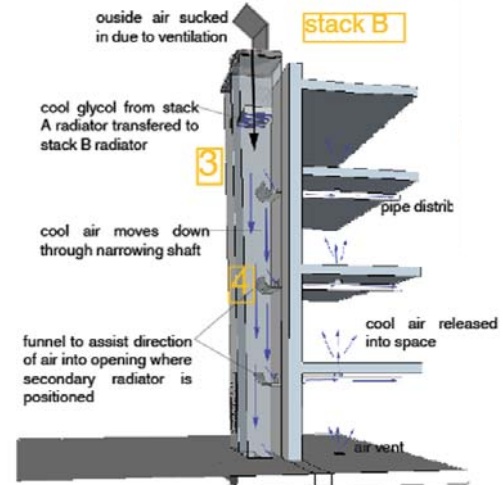

Fig.390: Cool air production, internal workings of stack B, side view

## DETAIL 01

### Southern Façade Stack

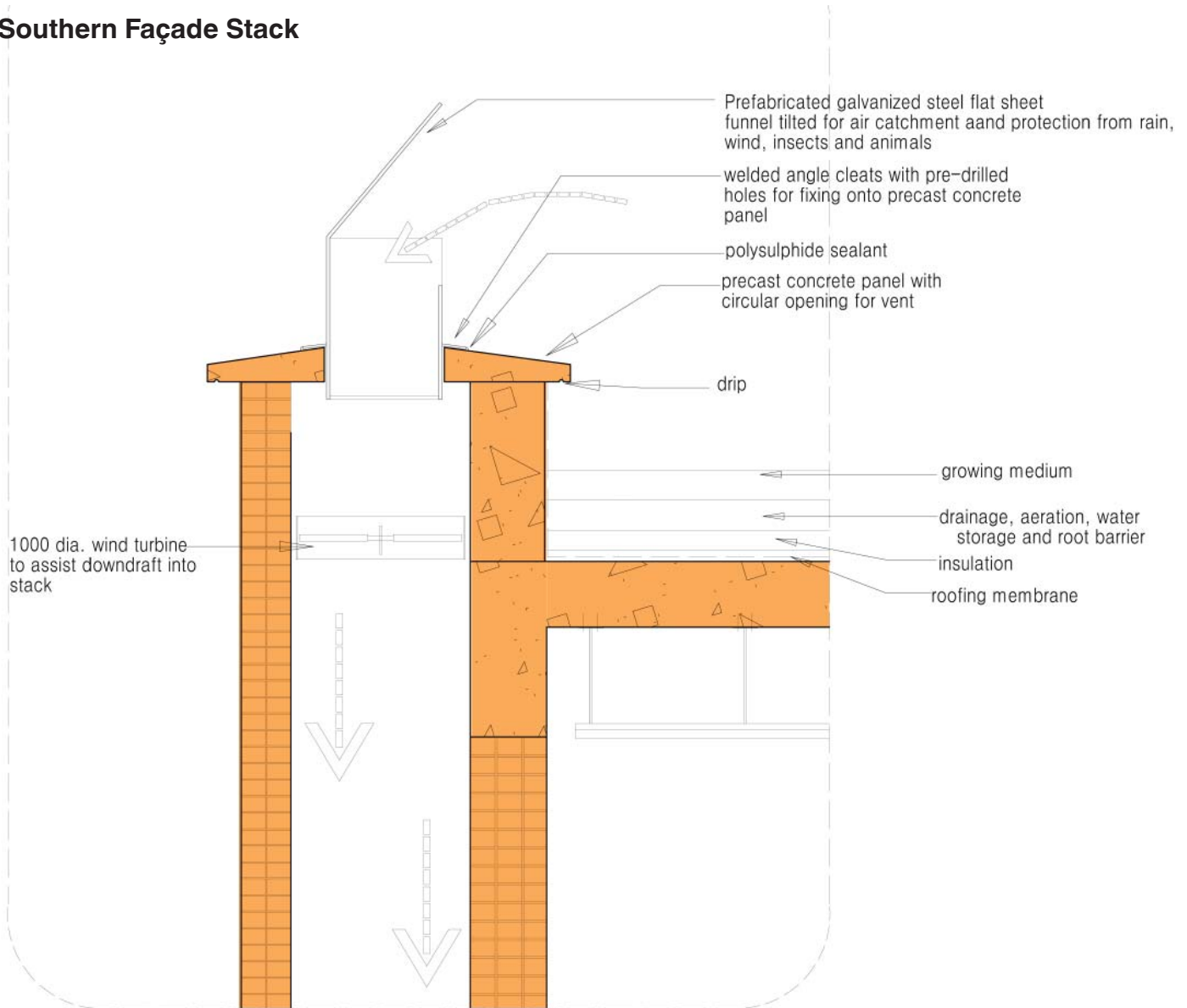

Fig.391:Southern façade stack - top condition

#### WHAT is the 'southern façade stack' ?

This is a masonry air shaft with openings into the building allowing fresh air into a designated space. The stack is divided into two shafts.

#### WHERE is it located?

It is found on the southern façade of the building

#### WHY is it used in the design?

It is used in the ventilation of the building, where air dispelled from the solar chimney on the northern façade, creates displaced air, thus new air is suck into the building through the southern façade stacks.

It is also used to provide cool air for the building : one shaft provides fresh air into the building, the second shaft allows the cooling of glycol in a radiator that provides cool glycol to circulate in secondary radiators at each level of the building. This provides cool air for the building.

## DETAIL 02

### Southern Façade Stack

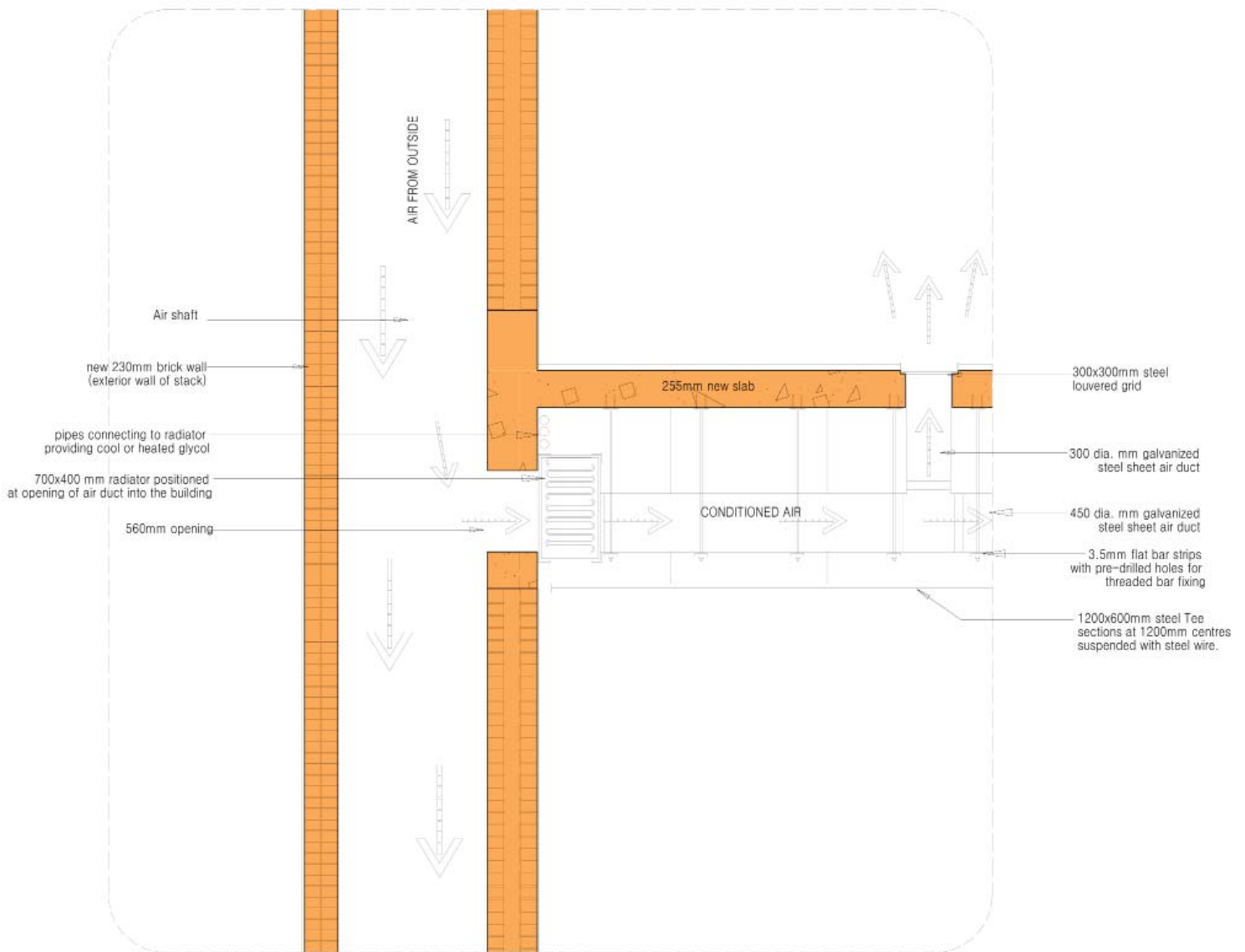

Fig.392: Southern façade stack - middle condition

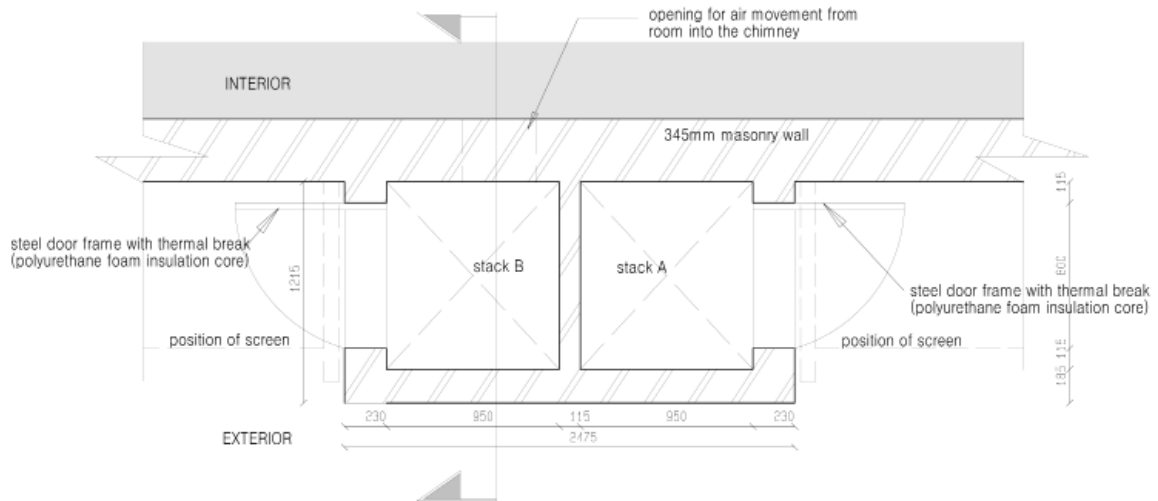

Fig.393: Plan of southern façade stack



Fig.394: Exterior appearance of southern façade stack

## DETAIL 03

### Trombe Assisted Solar Chimney

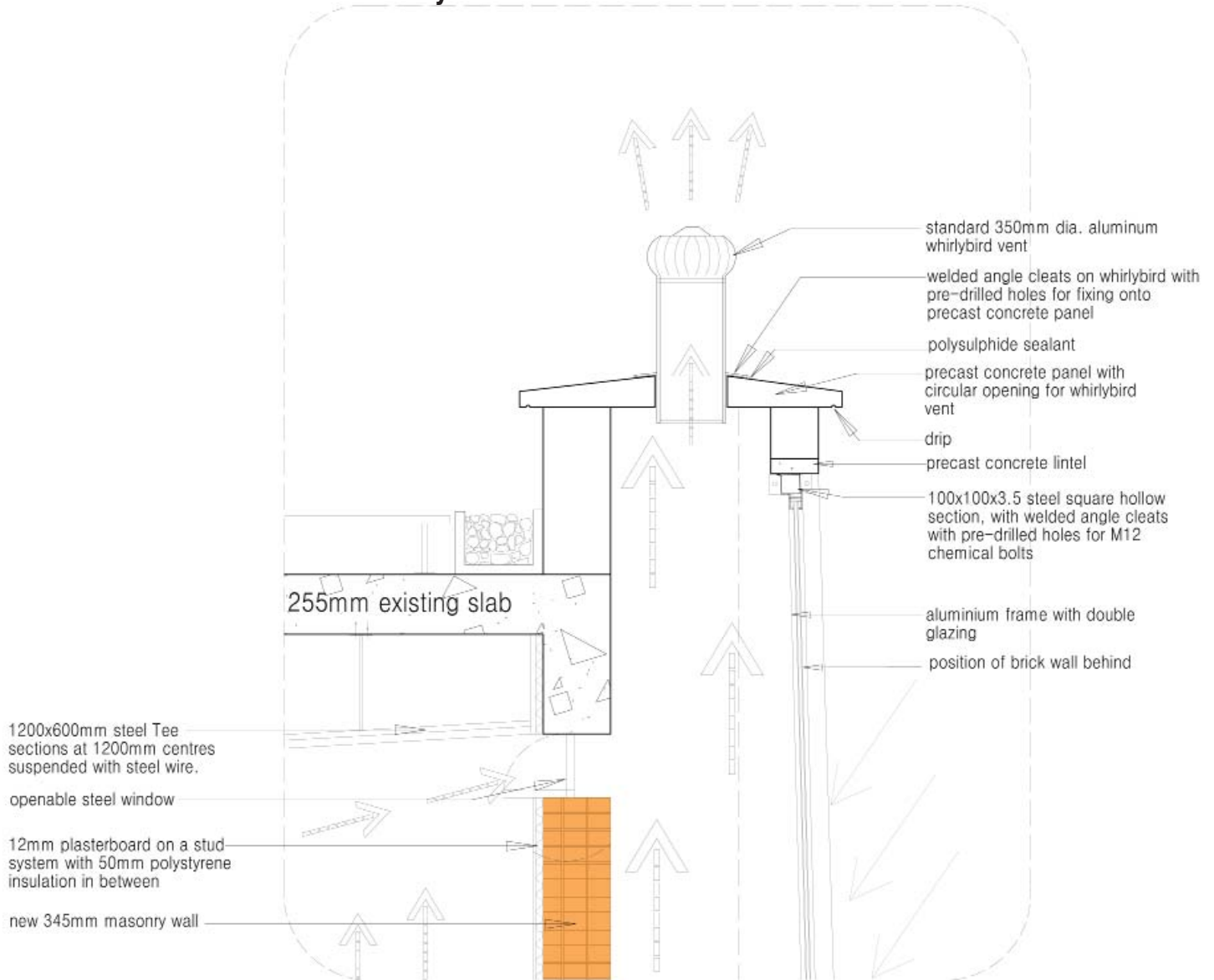

Fig.395:Section through Trombe Assisted Solar Chimney - top condition

#### WHAT is the 'trombé assisted solar chimney' ?

A trombé assisted solar chimney is a masonry air shaft with openings at every floor level allowing air to exit the space, into the shaft and into the atmosphere. The north facing façade has double glazing , which traps longwave radiation.

#### WHERE is it located?

It is found on the northern façade of the building

#### WHY is it used in the design?

It is used in the ventilation of the building. The trombé assisted solar chimney is heated due to the accumulation of longwave radiation from solar energy exposure on to the glass panel. This causes negative pressure in the stack, thus the warm air rises. This also encourages the movement of air from the room towards the opening of the trombé stack.

## DETAIL 04

### Southern Façade Stack

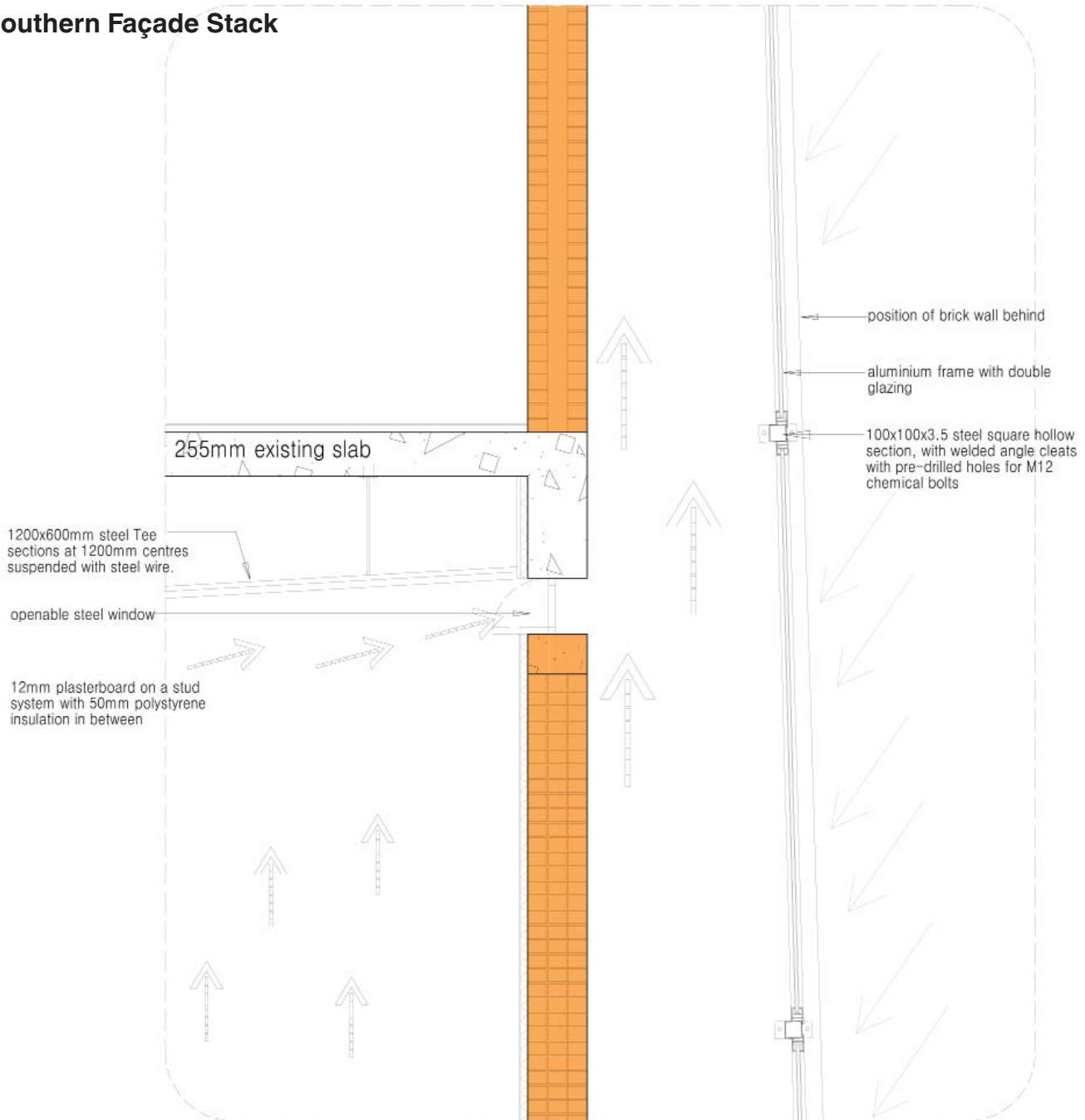
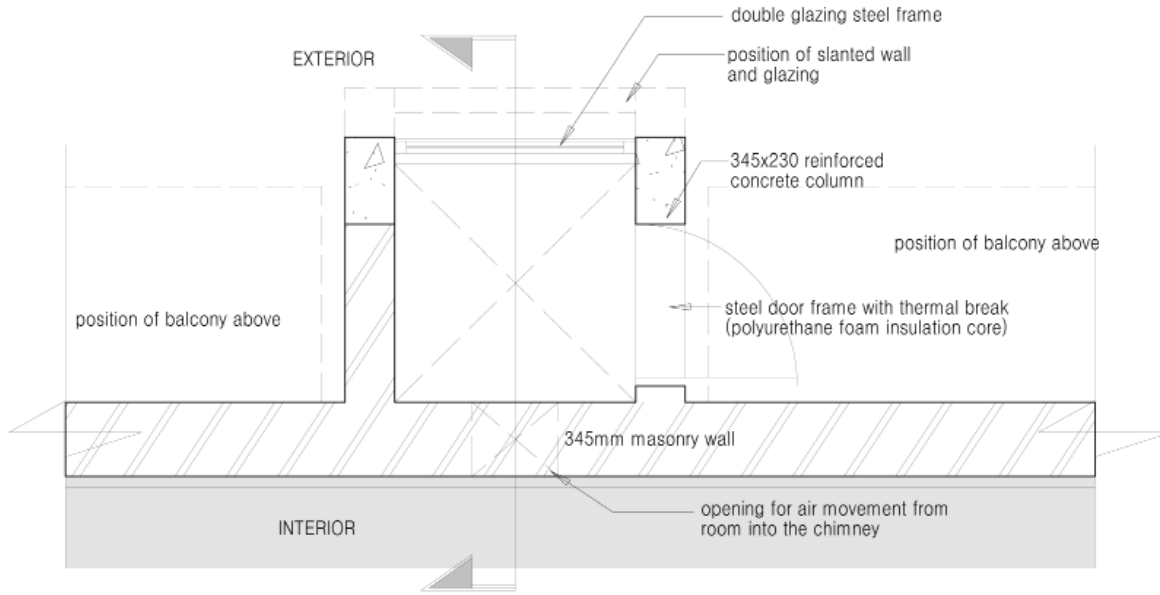
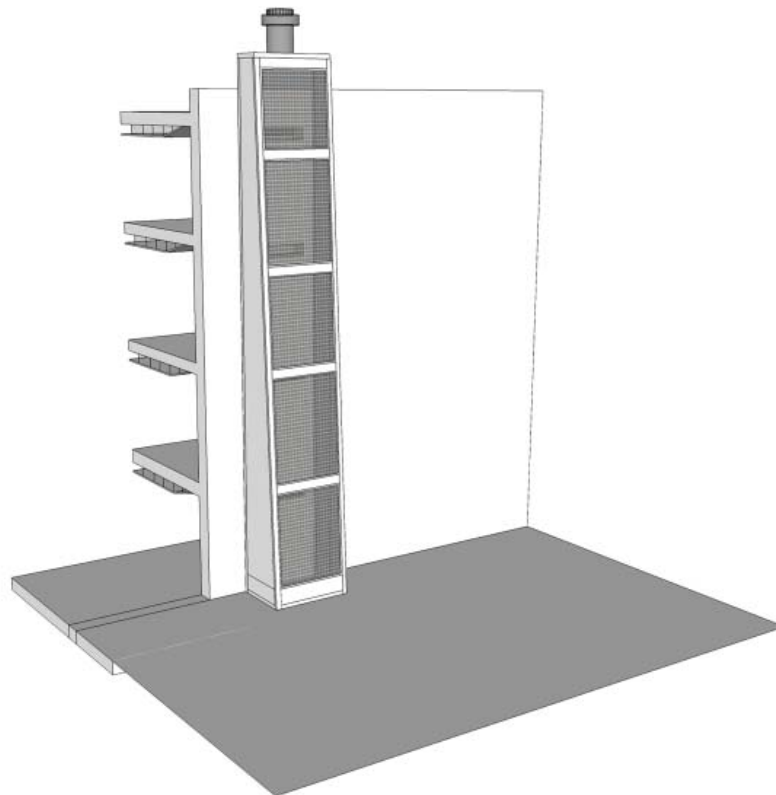

Fig.396:Section through Trombe Assisted Solar Chimney - middle condition



*Fig.397:Plan of Trombe Assisted Solar Chimney*



*Fig.398:Exterior appearance of Trombe Assisted Solar Chimney*

## 8.4 FAÇADE TREATMENT

### 8.4.1 SOUTH FAÇADE SCREEN SYSTEM

As mentioned, GKD mesh is utilised on the southern part of the building as a protective (security) layer to a façade that is mainly comprised of glazing. This transparency portrays an image of openness between the European Commission and the South African public. It is also possible as the southern façade does not receive harsh solar exposure.

The screen also acts as a unifying element from the auditorium to the main entrance of the building.

GKD metal fabrics are non-corrosive, durable, heat, fire and impact resistant and sustainable for all climates and environments.

According to GKD Metal Fabric (2011),

- Stainless steel used in GKD metal fabrics contains 35% post industrial and 25% post consumer content recycled material.
- Recyclable directly correlates with minimization of waste
- Recycling stainless steel involves no health hazardous materials
- Utilizing GKD metal fabrics is an environmentally responsible and resource efficient choice
- does not require a surface coating that can deteriorate and possibly pollute the environment
- does not require hazardous cleaning products to maintain
- is 100% recyclable, retaining its' inherent qualities throughout the recycling process
- is low maintenance
- Is accepted by LEED®

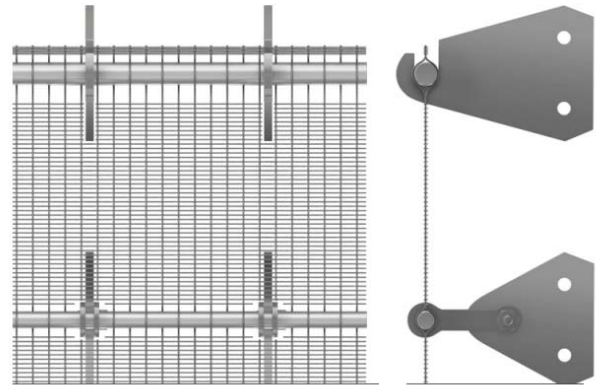

Fig.399: GKD mesh, Woven-in bar with spring, top and middle attachments [Source: [www.gkdmetalfabrics.com/pdf/attachments/woven-in\\_bar\\_with\\_spring.pdf](http://www.gkdmetalfabrics.com/pdf/attachments/woven-in_bar_with_spring.pdf), accessed 2 October 2011]

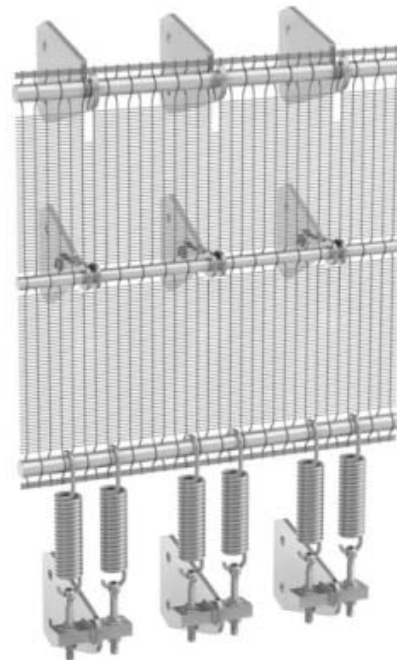
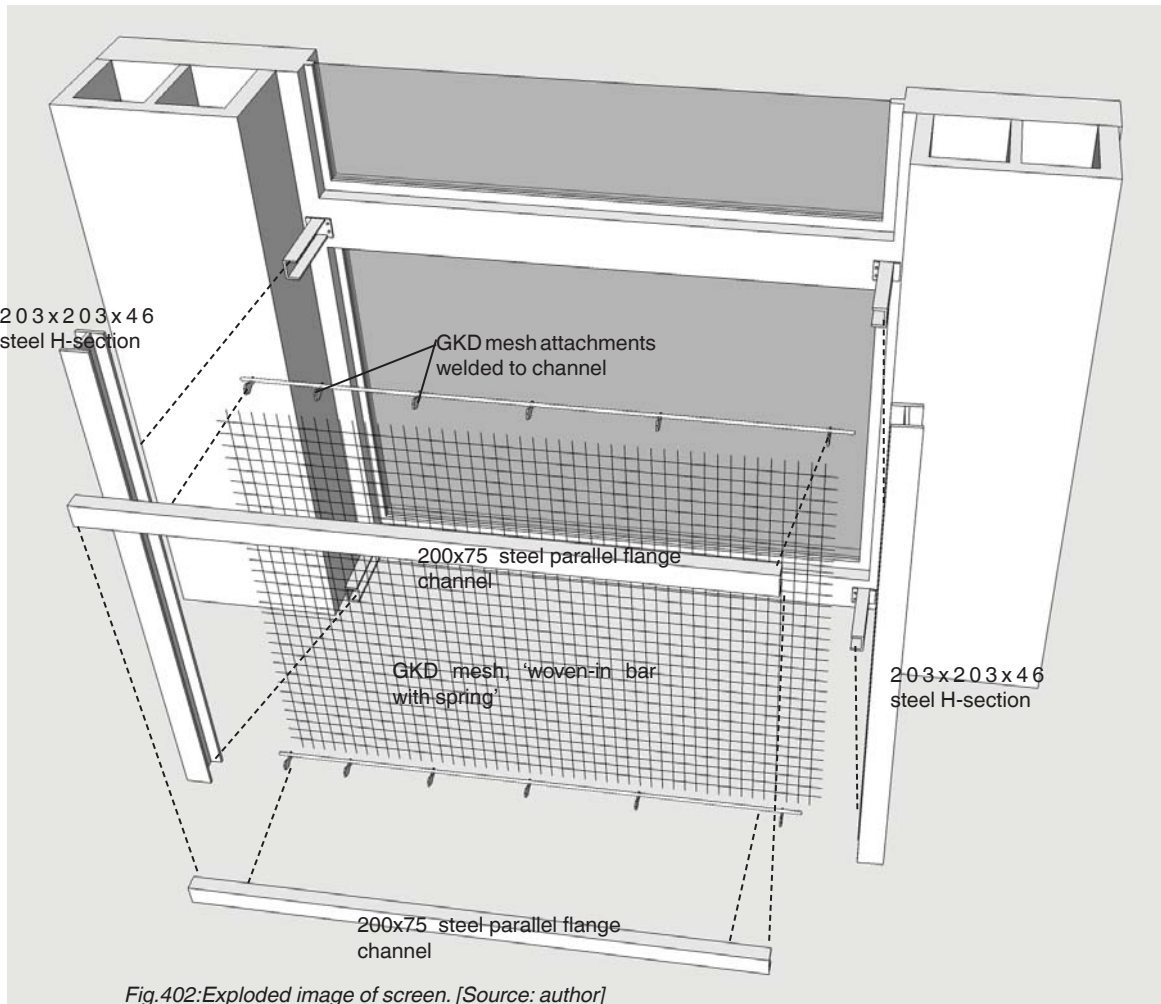
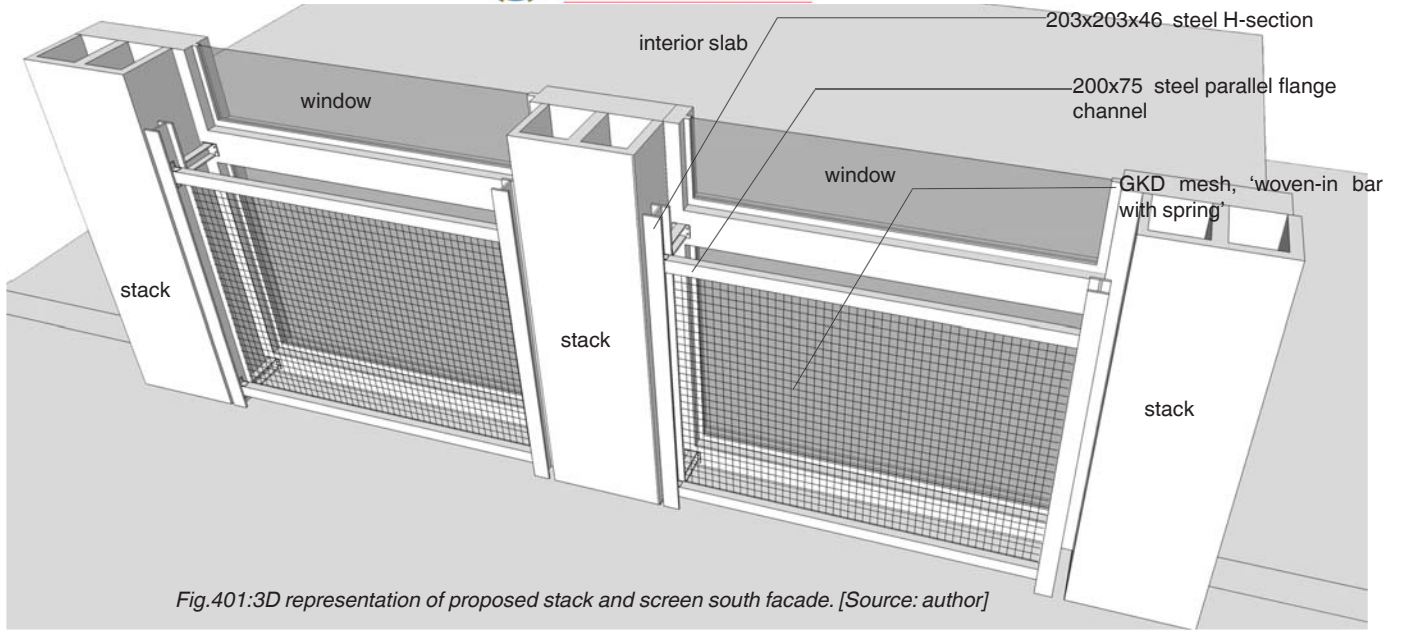

Fig.400: GKD mesh, Woven-in bar with spring [Source: [www.gkdmetalfabrics.com/pdf/attachments/woven-in\\_bar\\_with\\_spring.pdf](http://www.gkdmetalfabrics.com/pdf/attachments/woven-in_bar_with_spring.pdf), accessed 2 October 2011]





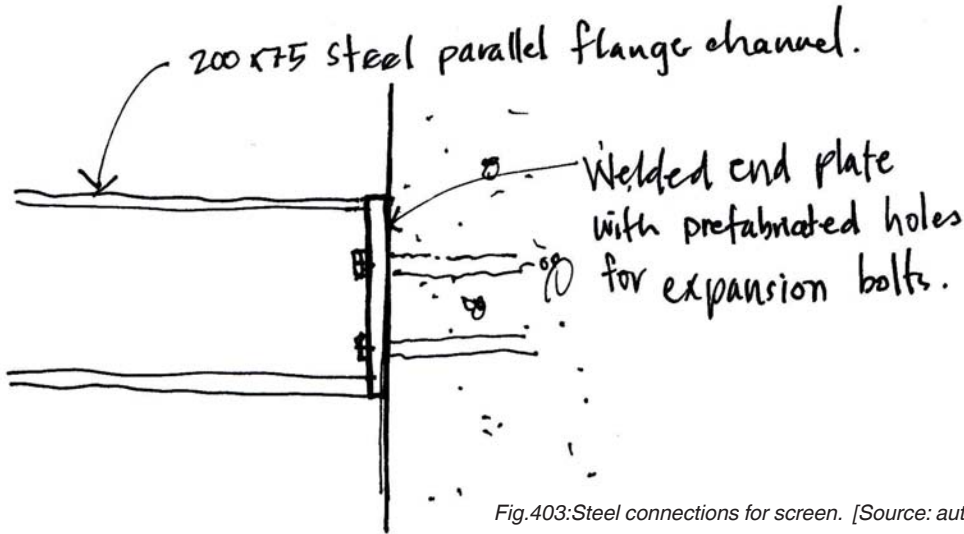
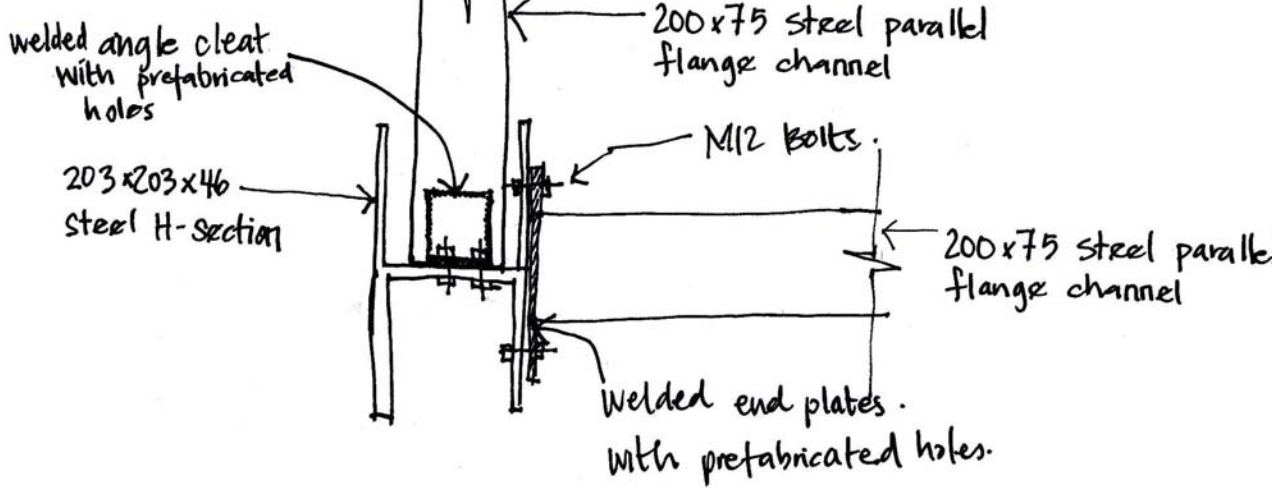
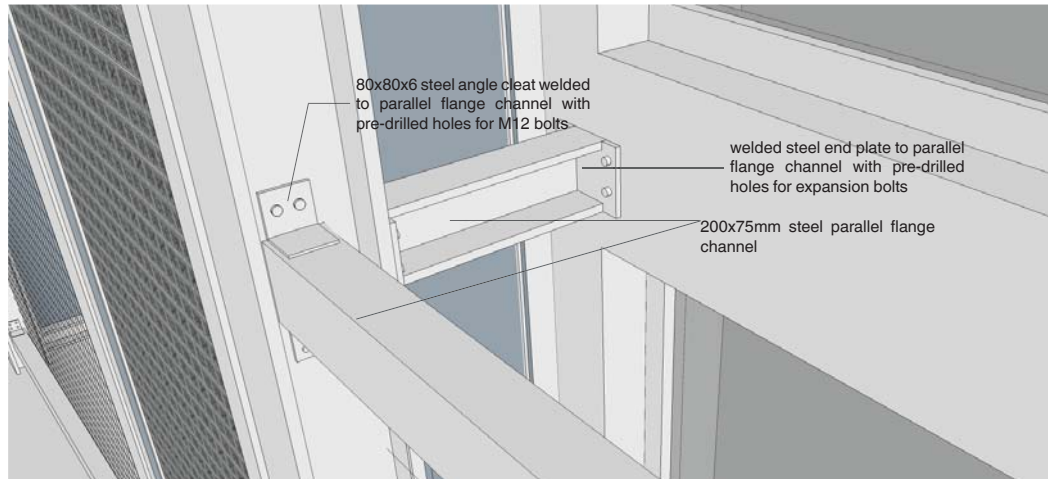

Fig.403:Steel connections for screen. [Source: author]



## DETAIL 05

### Screen Detail

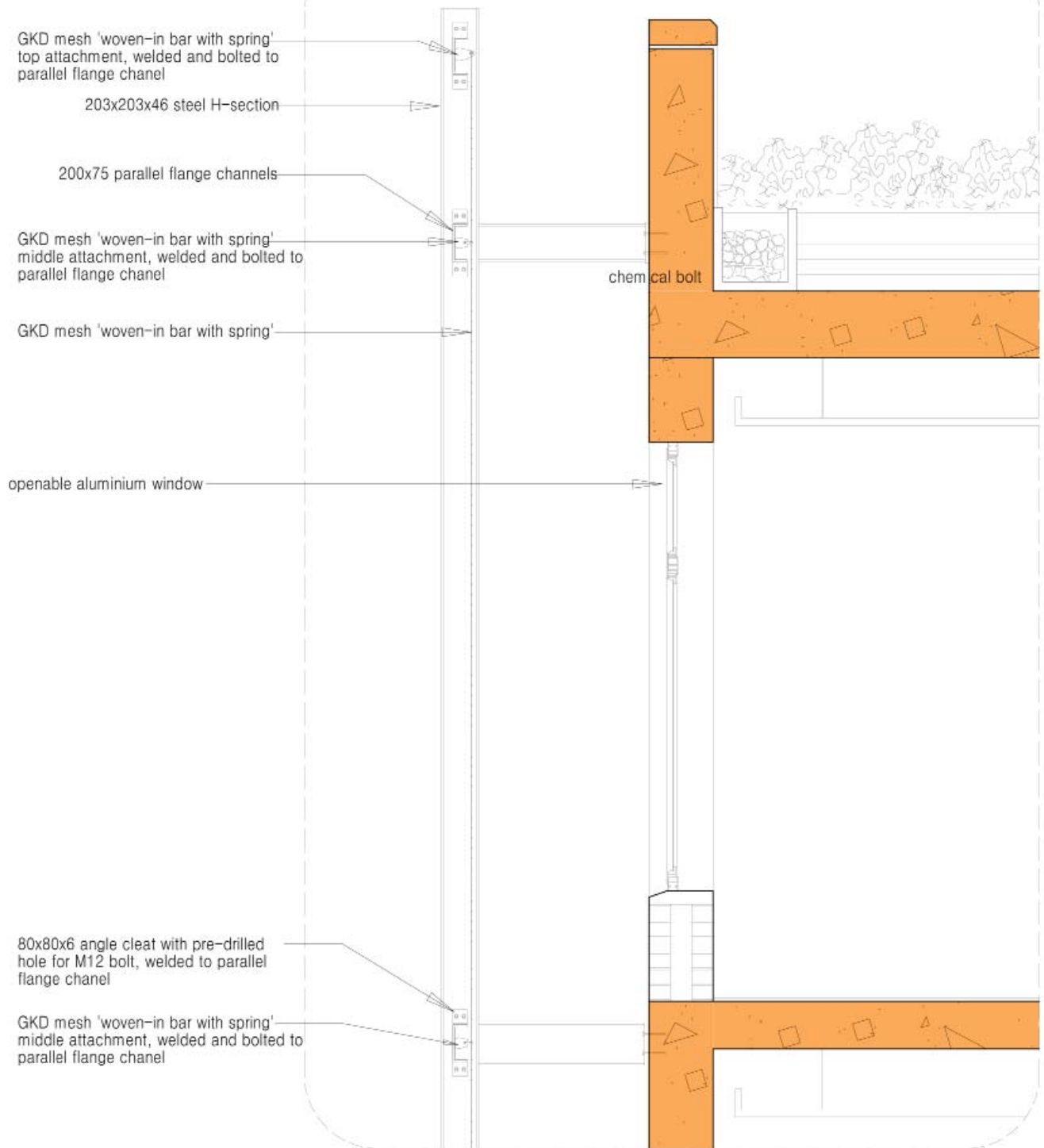

Fig.404:Screen detail with GKD mesh fixing. [Source: author]

## 8.4.2 NORTHERN FAÇADE TREATMENT

### Existing Façade

The existing northern façade has large opening with no solar control. For the open plan offices, glare, excessive heat gain and excessive sunlight is not conducive for a working environment.

### Concepts Applied to Existing Northern Façade

#### Light Shelf

The light shelf allows daylight to penetrate deep into the building. This horizontal light-reflecting overhang is placed at 2100mm. This surface is then used to reflect daylight onto the ceiling and deeper into the space.

#### Balconies

Users of the office spaces will benefit from access to outdoor air. Balconies provide visual connection to the exterior, smoke breaks and social interaction. The addition to the existing building acts as a shading device for the opening of the floor below.

#### Manually controlled blinds

Internal upward rolling retractable blinds are positioned at the openings, where manual control allows the users of the space to manipulate their comfort in terms of glare, and exposure to the moving sun.

#### Night purge openings

During the night, purge windows automatically open during summer, where night air cools the internal spaces.

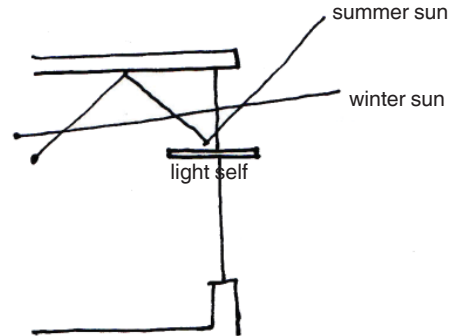

Fig.405:Light shelf concept [Source: author]

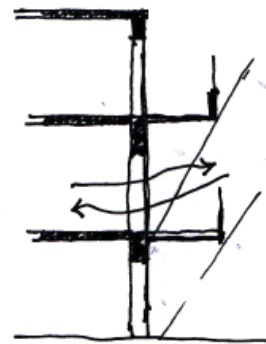

Fig.406:Balconies [Source: author]

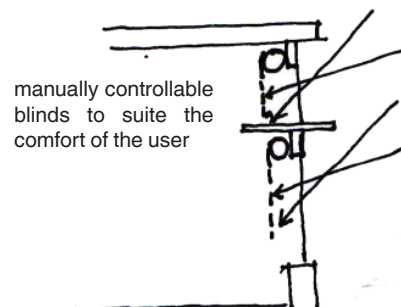

Fig.407:Manually controlled blinds [Source: author]

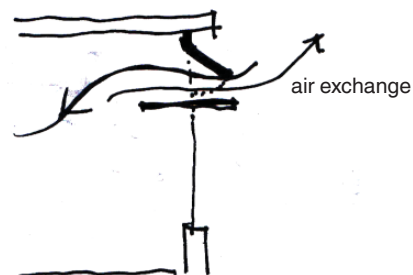

Fig.408:Night purge openings [Source: author]

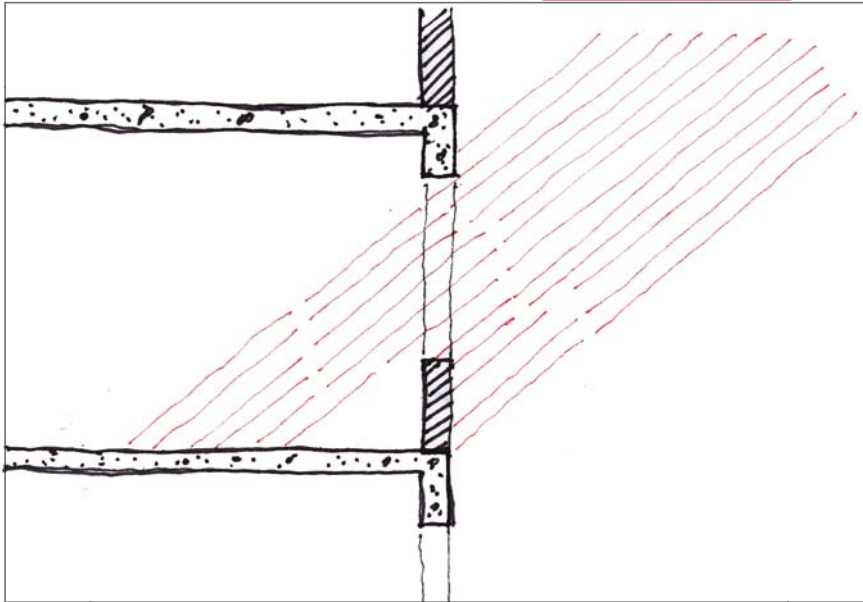

Fig.409:North facade existing condition with no solar protection  
[Source: author]

### Solar Angles

Fig 342 -345 utilises sun angles for Pretoria predicting the effects of the light self. Six times were investigated, 08hoo, 12h00 and 16h00 on the 21 December and 21 June.

Solar Times	06h00	08h00	10h00	12h00	14h00	16h00	18h00
Clock Times	06h18	08h18	10h18	12h18	14h18	16h18	18h18
Azimuth - 21 Desember	112 east	101 east	91 east	0	91 west	101 west	112 west
Altitude - 21 December	10	35	63	88	63	35	10
Azimuth - 21 March/September	90 east	76 east	53 east	0	53 west	76 west	90 west
Altitude - 21 March/September	0	26	51	65	51	26	0
Azimuth - 21 June	N/A	55 east	34 east	0	34 west	55 west	N/A
Altitude - 21 June	N/A	14	32	40	32	14	N/A

Fig.410: Table of solar angles in Pretoria [Source: Napier,2000]

Winter - 21 June  
at 08h00 and 16h00

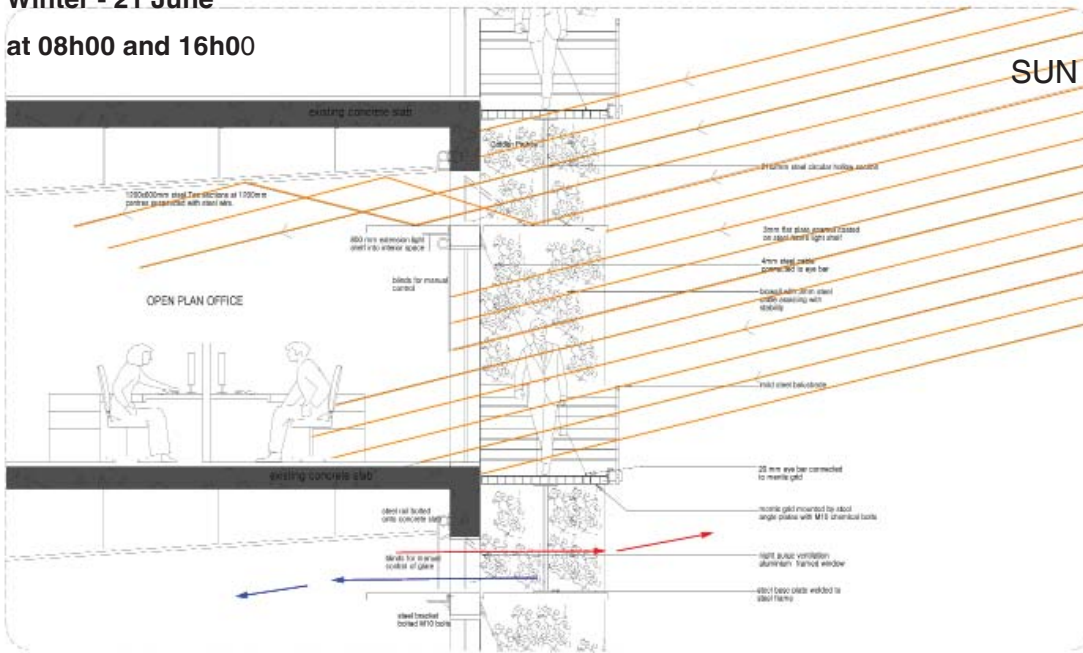

Fig.411: 21 June, Winter, solar angle condition at 08h00 and 16h00 ( solar angle at 14 degrees) [Source: author]

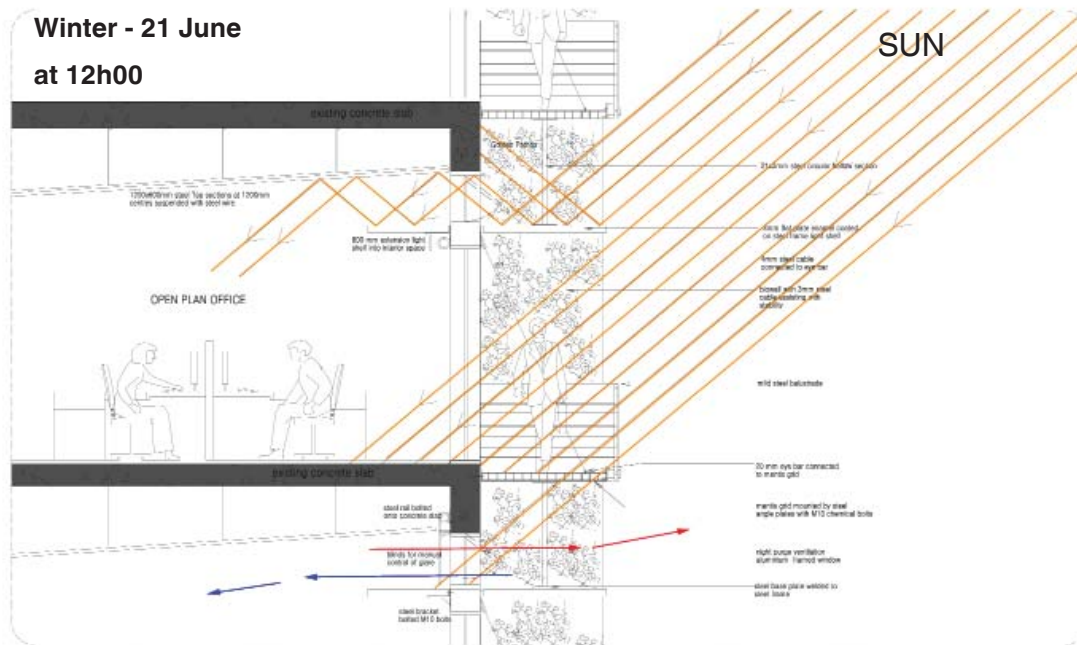

Fig.412: 21 June, Winter, solar angle condition at 12h00 (solar angle at 40 degrees) [Source: author]

Summer - 21 December  
at 08h00 and 16h00

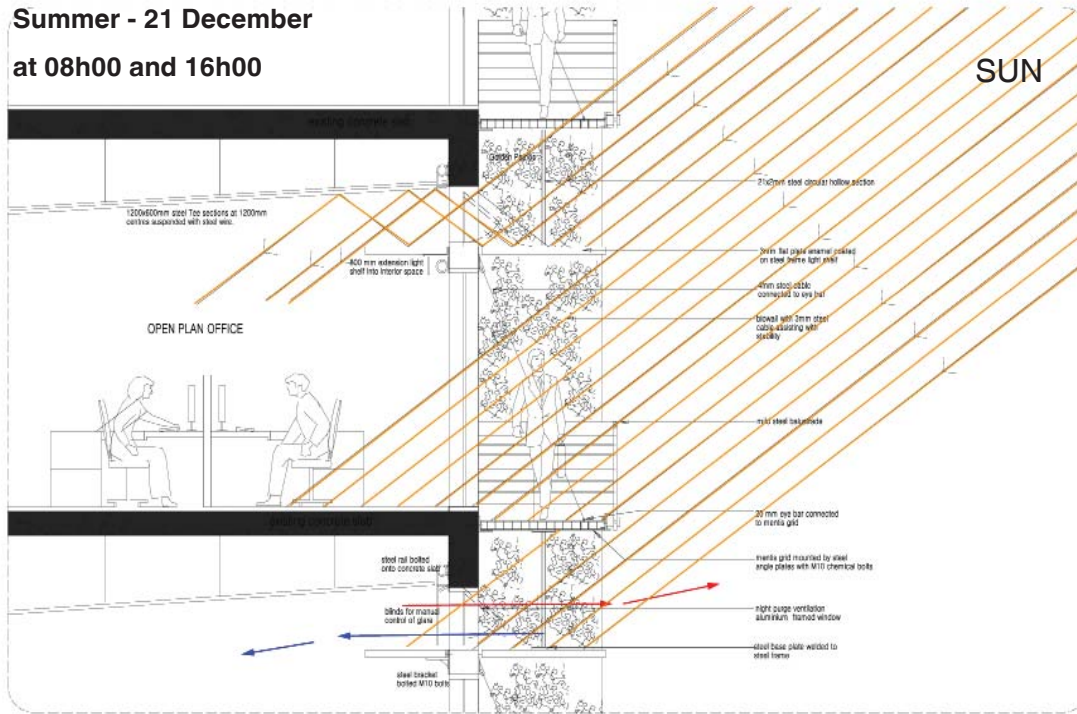

Fig.413: 21 December, Summer, solar angle condition at 08h00 and 16h00, (solar angle at 35 degrees) [Source: author]

December - 21 June  
at 12h00

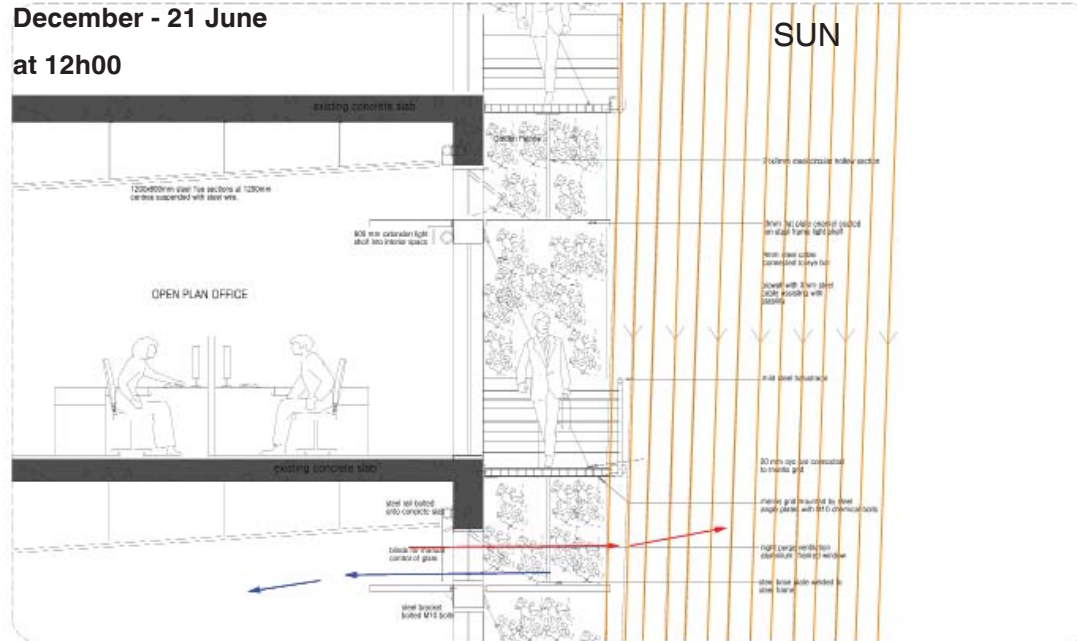

Fig.414: 21 December, Summer, solar angle condition at 12h00, (solar angle at 88 degrees) [Source: author]

## DETAIL 06

### North Façade Treatment

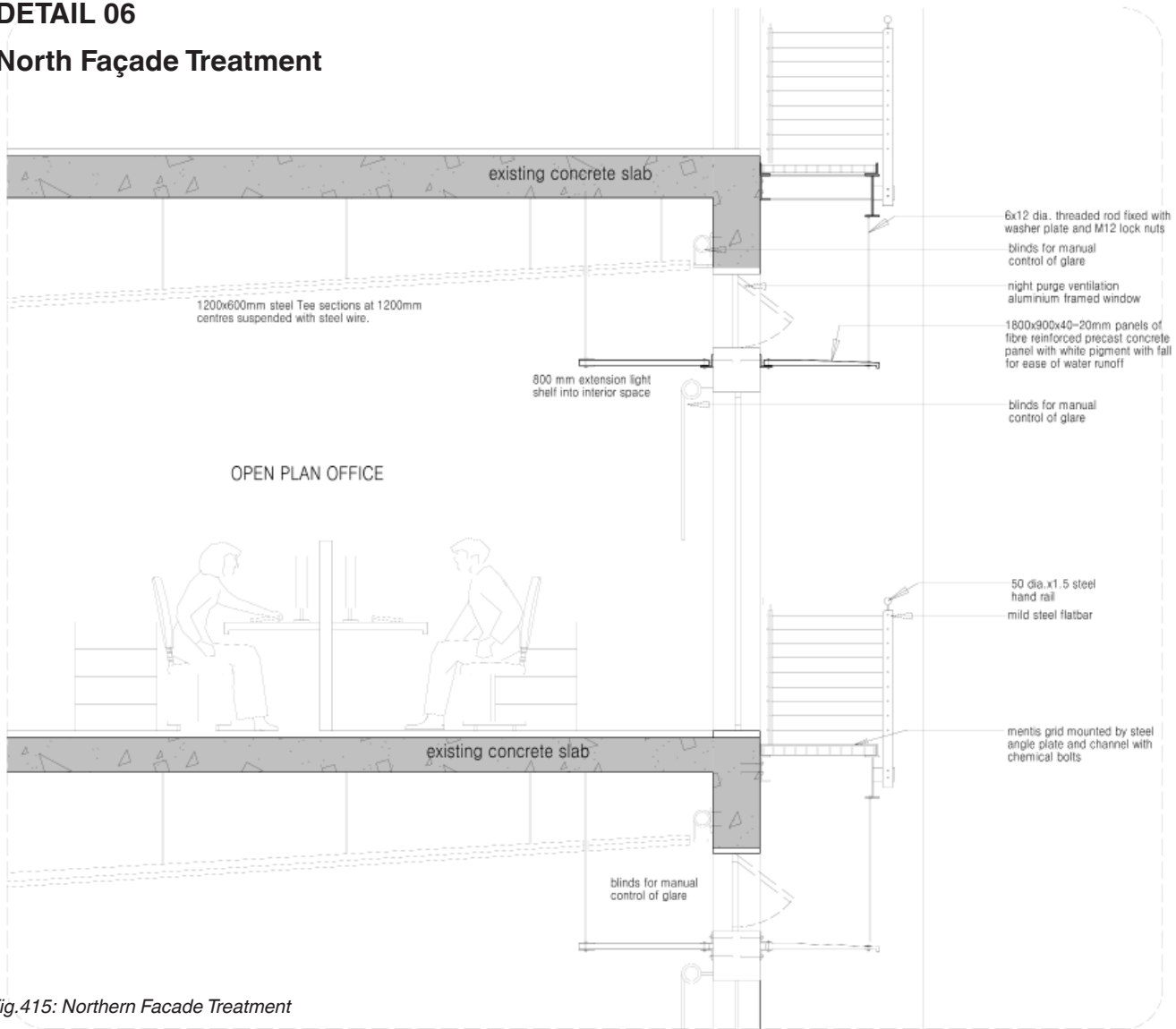

Fig.415: Northern Façade Treatment

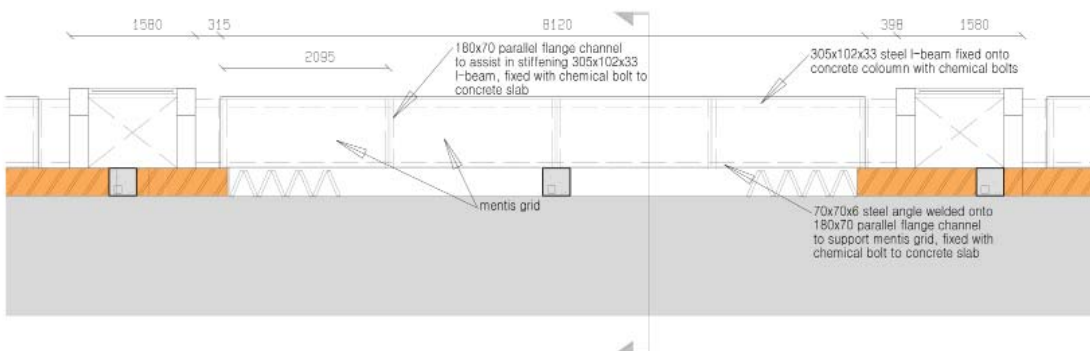

Fig.416: Plan of North Façade Treatment



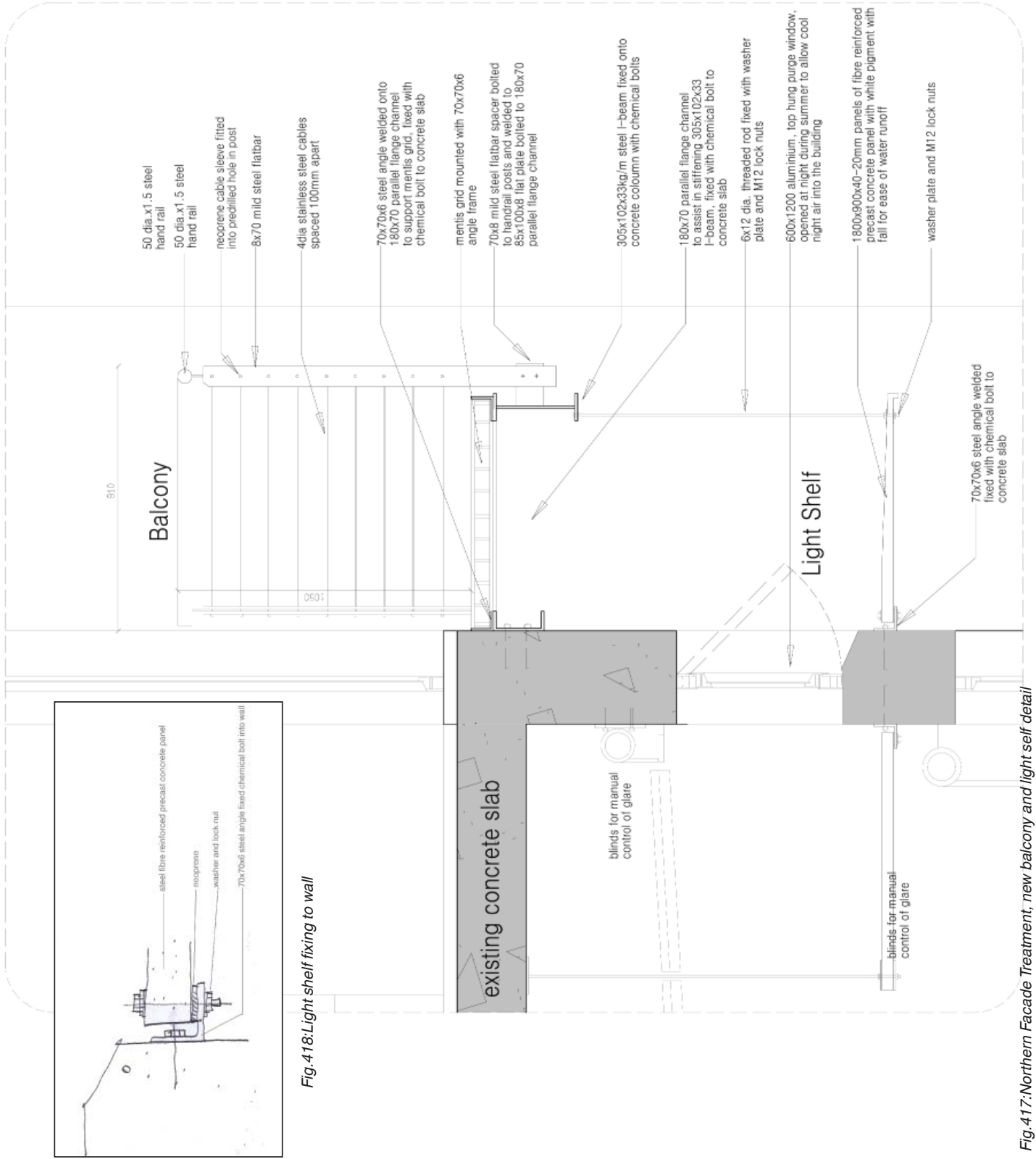

Fig.418:Light shelf fixing to wall

Fig.417:Northern Facade Treatment, new balcony and light self detail

## 8.5 Pergola Structure

### DETAIL 07

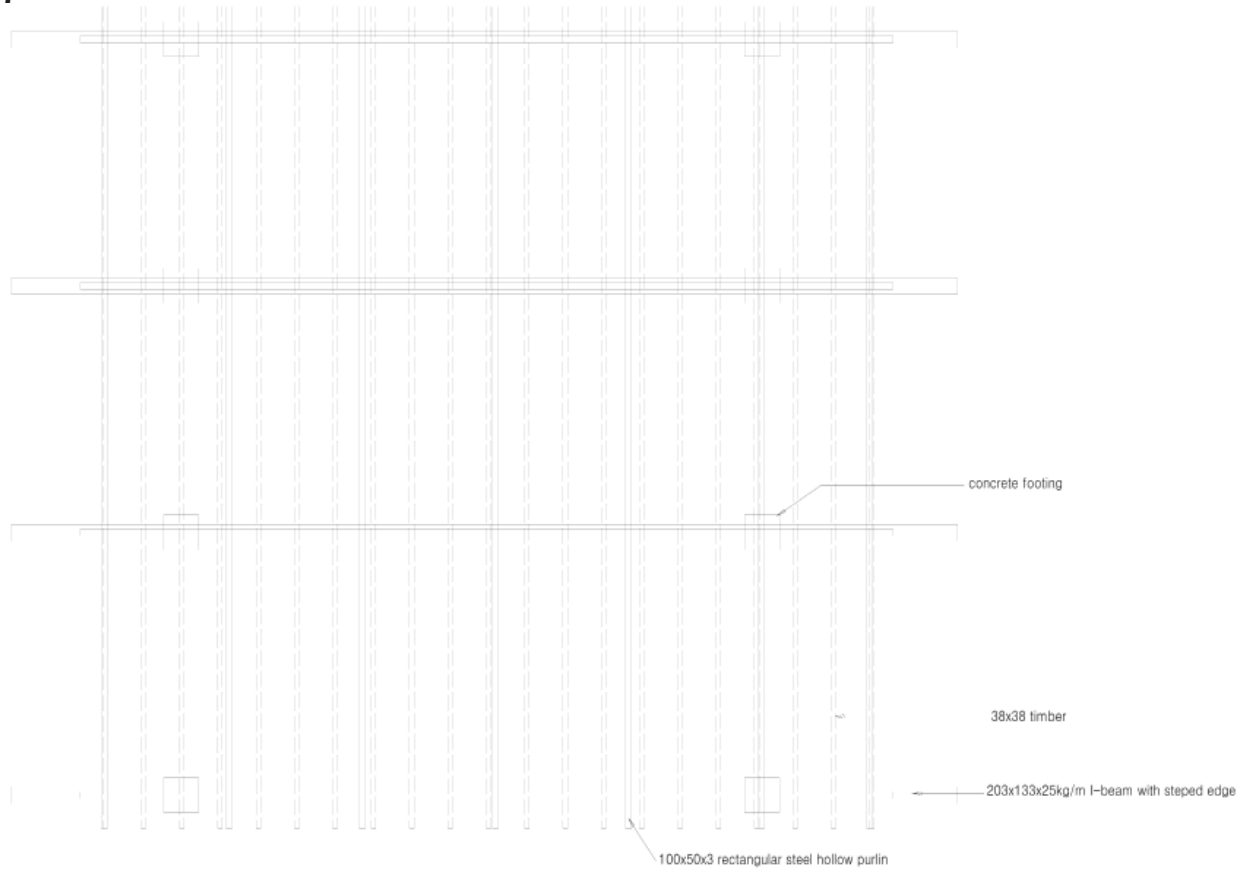

Fig.419: Plan of Pergola

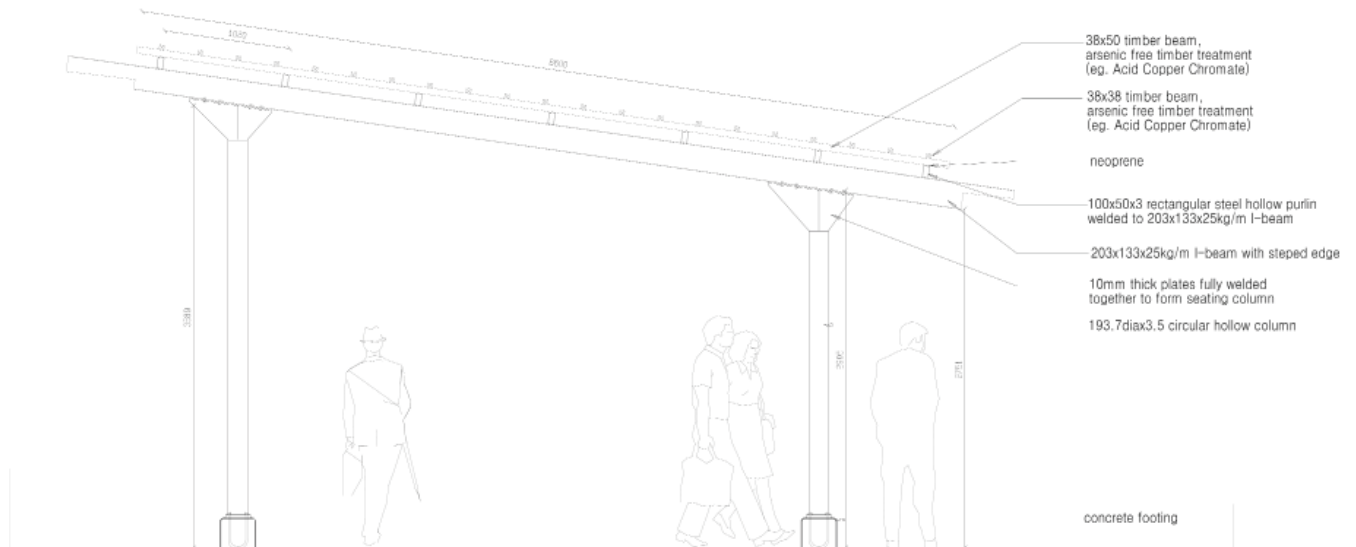

Fig.420: Section of Pergola

### 8.5 Stairs DETAIL 08

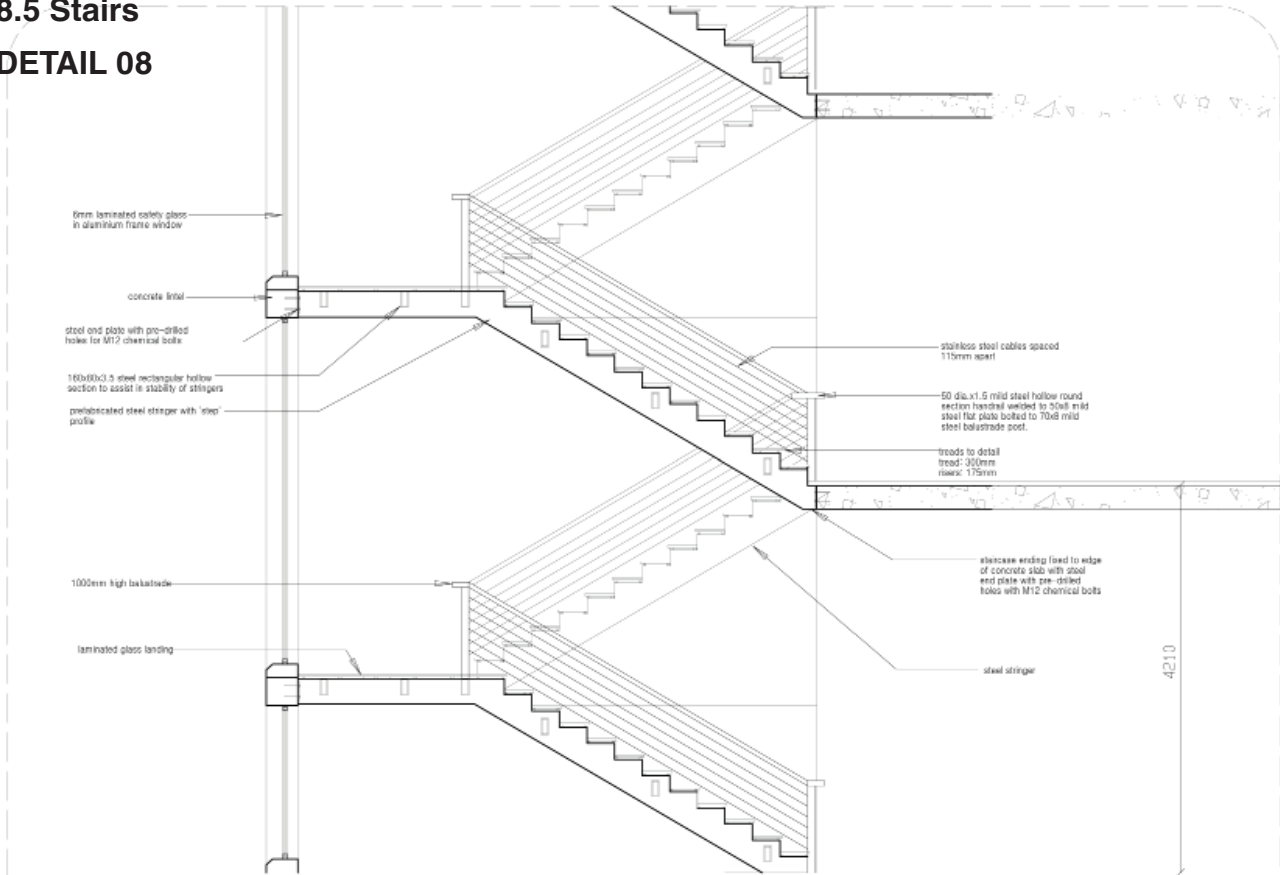

Fig.421: Section of Glass Stairs

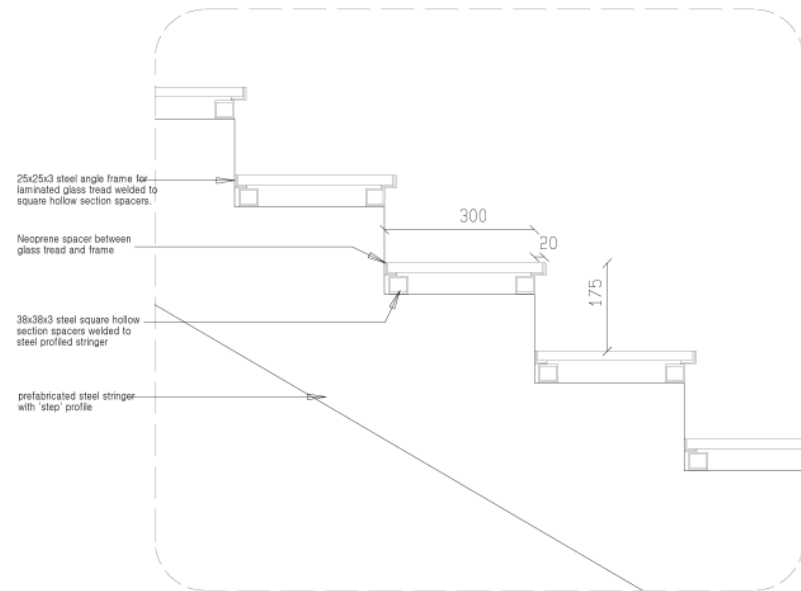

Fig.422: Detail of Stairs

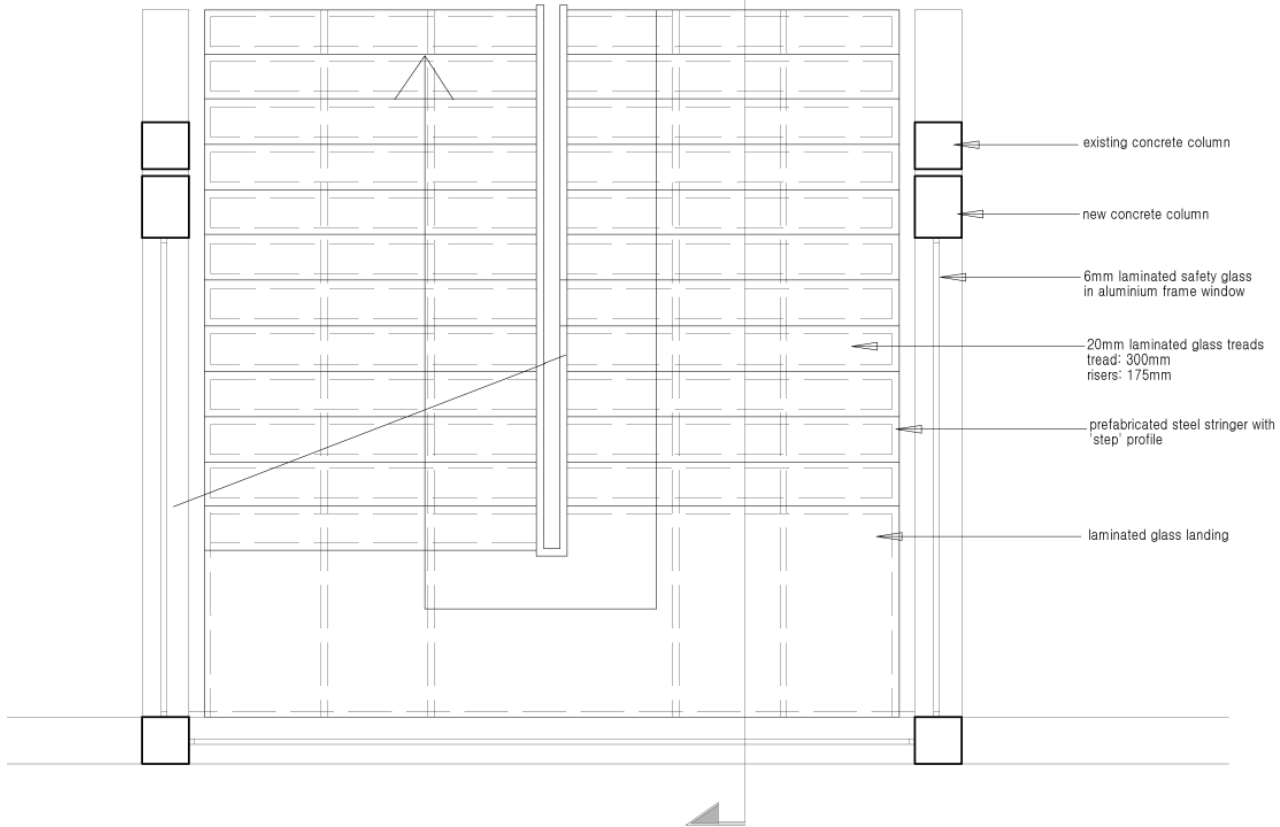

Fig.423: Plan of Stairs

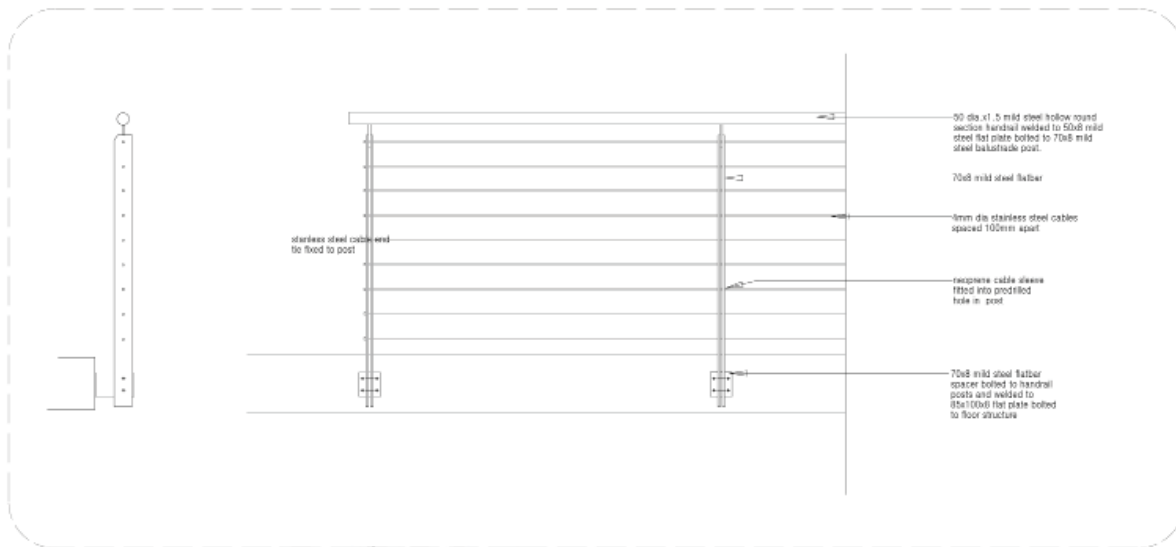

Fig.424: Balustrade Detail

## 8.6 RAINWATER RECYCLING

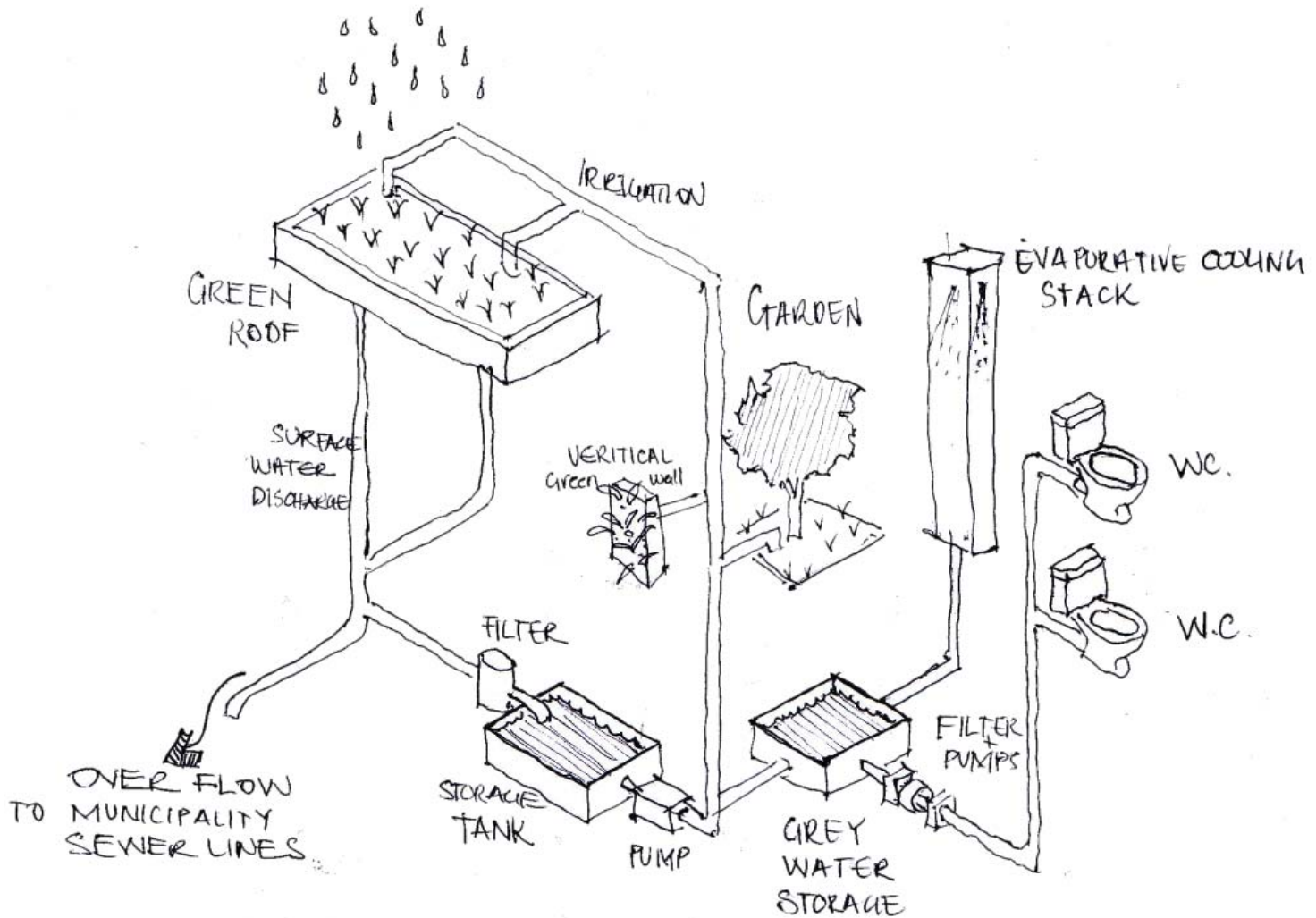

Fig.425: Proposed recycle water cycle for the Agrivaal Building

### Water recycling

Rain water from the concrete roof will be utilised

Rain water from the concrete roof will be utilized for the irrigation purposes of the roof garden. Runoff will be directed (refer to fig 312) through the filter system and then into a storage tank. A pump directs the water for irrigation purposes back to the garden roof, the vertical garden on then northern façade of the building and the general landscape. This water is also utilized for toilets and the heating and cooling system that requires water for evaporative cooling.

## 8.7 SBAT

The SBAT rating tool was used to evaluate the design. The Sustainable Building Assessment Tool provides an indication of the performance of a building or the design of a building in terms of sustainability.

The tool is ideally used on a building that has recently been completed, however for the purpose of this project it will be used theoretically. An assessment of the building in its current condition will be recorded, and a second assessment will be done in terms of the new proposed design.

The rating tool is divided into three components namely social, economic, environmental components.

The social component includes aspects such as access to natural light, proximity and access to public transport, disabled access to functions, noise and air pollution.

The economic component provides an indication of the economical performance including cost of construction and material, locally sourced materials and the use of local labor instead of specialized labor.

The environmental component deals with recycling of waste, water consumption and reuse, greening of the site etc.

According to the tool, the existing building receives 1.2/5, classifying it as 'very poor condition'. All aspects concerning the building received low rating.

The proposed design receives 3.7/5, which is an improvement from its existing state. Areas of 'participation and control' received very low marks as the building is not in use yet.

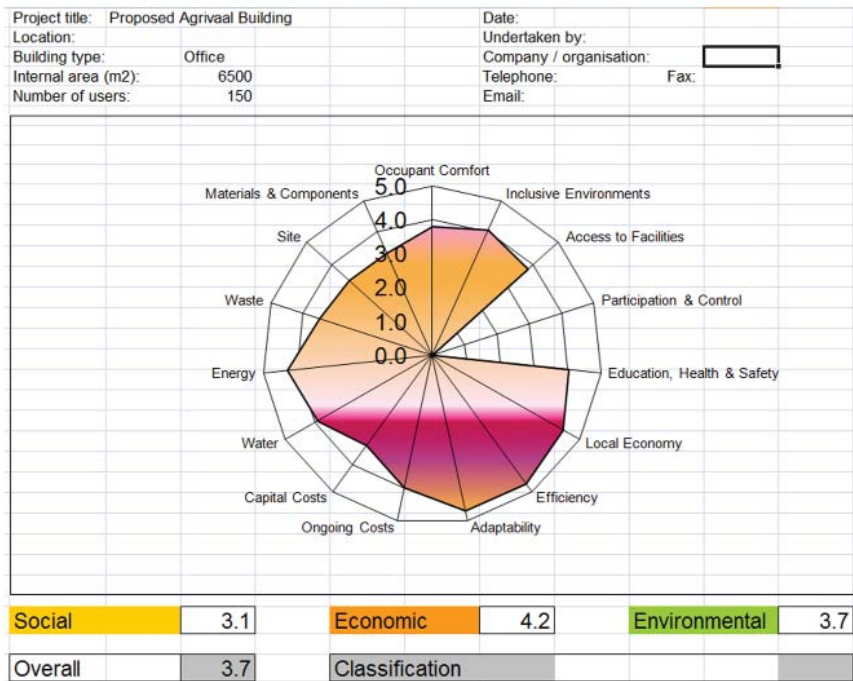
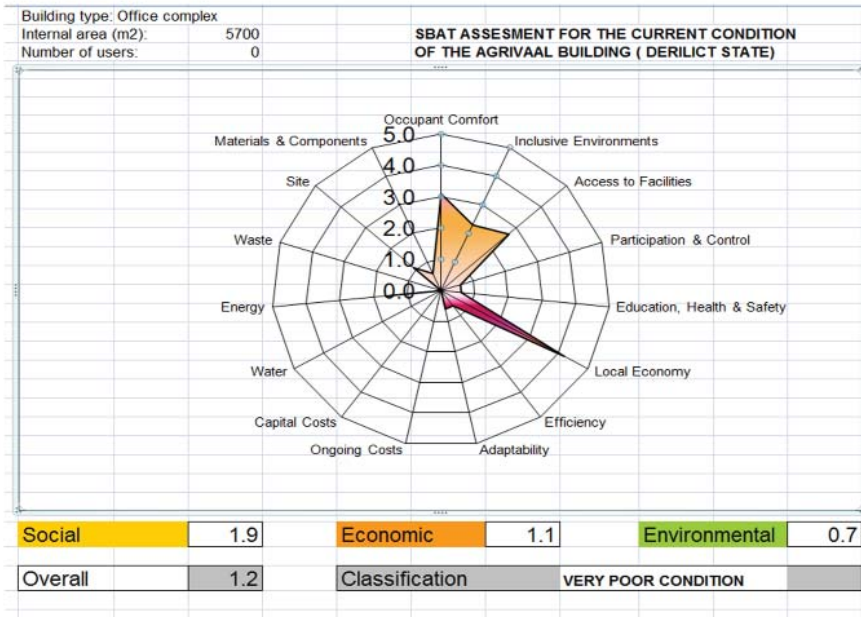

## References:

### Books and Articles

ADAMS, S. L. 2002. *Art across time*. New York: McGraw-Hill

BRADLEY GUY, G. 2003. The Architect. In: KIBERT, C. J., SENDZIMIR, J. & BRADLEY GUY, G. *Construction ecology. Nature as the basis for green buildings*. C.J. Kilbert, J. Sendzimir & G.B. Guy [eds.] London: Spon Press

BRAND, S. (1995). *How buildings learn, what happens after they're built*. London: Penguin Books.

BUCHANAN, P. 2005. *Ten shades of green, architecture and the natural world*. New York: The Architectural League of New York

CAPRA, F. 1997. *The web of life*. New York: Anchor Books

CARSON, R. 1962. *Silent Spring*. New York: Houghton Mifflin Company

CLARKE, N. 2009. *Brief Background History of the Agrivaal Building Complex*. In: Agrivaal Building Heritage Impact Assessment.

NB: the above reference consisted of only a draft version of a chapter that has analysis of the Agrivaal Building and no other information was released pertaining to the Heritage Impact Assessment.

Du PLESSIS, C., IRURAH, D.K. & SCHOLES, R.J. 2003. *The built environment and climate change in South Africa. Building research & information* (2003) 21 (2-4), p240-256

EU Climate Action, October 2010 on *Climate change*. European Union

European Union and South Africa. 2010. *European union and South Africa development partners progress 2 report 2010*. European Union

FISHER, C. 1998. From Brazil to Pretoria, in Fisher, R.C. Le Roux, S & Mare E. *Architecture of the Transvaal*. Pretoria: UNISA

- GERNEKE, G. 1998. *From Brazil to Pretoria*, in Fisher, R.C. Le Roux, S & Mare E. Architecture of the Transvaal. Pretoria: UNISA
- GIBBERD, J. 2009. *Green building handbook for South Africa*. Pretoria: CSIR
- GREEN BUILDING COUNCIL OF SOUTH AFRICA(GBCSA). 2008. *Technical manual green star SA – office v1*. 1st edition. GBCSA
- GROÁK, S. (1993). *The idea of building*. London: E & FN Spon.
- GUY,G.B.2003.The architects in construction ecology. Nature as basis for green buildings. C. J. Kibert (ed), J. Sendzimir (ed) G.B. Guy (ed) London: Span Press: 227-229
- HERITAGE CANADA FOUNDATION. 2001. *Exploring the connection between built and natural heritage, energy and waste conservation*.
- HOLM, D. 1998. *Manual for energy conscious design*. Pretoria: Department of Minerals and Energy, Directorate Energy for Development
- JACCARD, M. 2005. *Sustainable fossil fuels*. New York: Cambridge University Press.
- JOHN, R. 2008. *Intervention. The society of British interior design*.
- JACOBS, J. 1993. *The death and life of great American cities: The Failure of Town Planning*. Harmondsworth: Random House
- KIBERT, C. J., SENDZIMIR, J. & BRADLEY GUY, G. 2003. *Construction ecology. Nature as the basis for green buildings*. C.J. Kibert, J. Sendzimir & G.B. Guy [eds.] London: Spon Press



NAPIER, A. 2000. *Enviro-friendly methods in small building design for South Africa*. Pretoria

OMM. (2007). *The Sophia Grey lecture, borrowing space and time: contributing to the reconception of modern African space*. Architecture South Africa , 14-21.

PEARSON,C. 2011. *What now?*. Architectural Record, Vol 10, pp.20-28

PLESSIS, C., IRURAH, D., SCHOLES, R.J. 2003. *The built environment and climate change in South Africa*. Building Research & Information. 31:3, 240 - 256

RANDELLI, A. 2005. *Tsonga environmental centre and local sustainability catalyst, Cape Town South Africa*. Holcim Awards for Sustainable Construction , 11.

RATTENBURY, K., Bevan, R., & Long, L. (2004). *2004 Architects today*. London: Laurence King Publisher.

ROWE, P. 1987. *Design thinking*. London: Penguin.

SCOTT. F. 2008. *On altering architecture*. New York: Routledge

SOUTH AFRICA DEPARTMENT OF ENVIRONMENTAL AFFAIRS. 2010. *National climate change response green paper 2010*. Pretoria: Government Printer

SMITH. F.S. 2001. *Architecture in a climate of change – a guide to sustainable design*. Oxford: Architectural Press

THE DELEGATION OF THE EU IN SA. 2009. *European union and South Africa*. EU

THE AUSTRALIA ICOMOS CHARTER FOR PLACES OF CULTURAL SIGNIFICANCE (The Burra Charter).1999. Australia ICOMOS

WELLS, M. 2003. *Green Architecture*. In: KIBERT, C. J., SENDZIMIR, J. & BRADLEY GUY, G. Construction ecology. Nature as the basis for green buildings. C.J. Kilbert, J. Sendzimir & G.B. Guy [eds.] London: Spon Press

WILBY, R.L. 2003. *A Review on climate change Impacts on the built environment*. Built Environment, Vol. 33, No1.

WILLIAMS, D.E. *Sustainable design – ecology, architecture and planning*. 2007. John Wiley & Son:New Jersey

## Electronic References

BDP. 2011. *Umoja house*. [online] Available at: <<http://www.bdp.com/Projects/By-Name/P-Z/Umoja-House/>> [Accessed 18 February 2011]

BURGER, W. 2009. *Can design change the world?* Interview on CNNTech interviewed by Manav Tanneeru. 6 November 2009 [online] Available at: <[http://articles.cnn.com/2009-11-06/tech/berger.qanda\\_1\\_design-prototyping-solving?\\_s=PM:TECH](http://articles.cnn.com/2009-11-06/tech/berger.qanda_1_design-prototyping-solving?_s=PM:TECH)> [Accessed: 5 July 2011]

CITY OF MELBOURNE. 2005. *CH2, council house how it works: City of Melbourne*. [online] Available at: <<http://www.melbourne.vic.gov.au/Environment/CH2/Pages/CH2Ourgreenbuilding.aspx>> [Accessed: 26 July 2011]

DEPARTMENT OF ENVIRONMENTAL AFFAIRS OF SOUTH AFRICA. 2005-2010. *State of the Environment*. [online] Available at: <<http://soer.deat.gov.za/175.html>> [Accessed 12 March 2011]

DOAN, A. 2007. *Green Building in Zimbabwe Modeled After Termite Mounds*. [online] Available at: <<http://inhabitat.com/building-modelled-on-termites-eastgate-centre-in-zimbabwe>> [Accessed 11 July 2011]

DODMAN, D. UNFPA (United Nations Population Fund) *Analytical review of the interaction between urban growth trends and environmental changes urban density and climate change*. [online .pdf document] Available at: <<http://www.unfpa.org/webdav/site/global/users/schensul/public/CCPD/papers/Dodman%20Paper.pdf>> [Accessed: 29 August 2011]

EUROPEAN COMMISSION ENVIRONMENT. 2009. *Sustainable development*. [online] Available at: <http://ec.europa.eu/environment/eussd/> [Accessed 3 October 2011]

EUROPEAN COMMISSION SOUTH AFRICA. 2011. *SA-EU strategic partnership*. [online] Available at: <<http://www.eusa.org.za/en/index.htm>> [Accessed 3 October 2011]

FONTAINE, P. 2010. *Europe in 12 lessons*. [online] Available at: [http://europa.eu/teachers-corner/15/index\\_en.htm](http://europa.eu/teachers-corner/15/index_en.htm) [Accessed: 21 September 2011]

FOX AND FOWLE ARCHITECTS. 2002. [online] Available at: <http://www.arcspace.com/architects/piano/NYT/> [Accessed: 22 September 2011]

GKD Metal Fabric. 2011. Available at: <http://www.gkdmetalfabrics.com/solutions/facades.html> [Accessed: 7 August 2011]

HARMONIA 57 BY TRIPTYQUE. [online] Available at: <<http://www.archdaily.com/6700/harmonia-57-triptyque/>> [Accessed 16 February 2011]

IPCC. 2007. *IPCC Fourth Assessment Report: Climate Change 2007*. [online] Available at: <[www.ipcc.ch/publications\\_and\\_data/ar4/wg2/en/ch9s9-3.html](http://www.ipcc.ch/publications_and_data/ar4/wg2/en/ch9s9-3.html)> [Accessed: 21 April 2011]

LARK, D. 2007. *Four goals of sustainable architecture*. [online] Available at: <<http://www.harmoniousliving.co.za/Environment/Eco-Friendly/The-Four-Goals-of-Green-Architecture/>> [Accessed: 21 February 2011]

PDC SOLAR. 2008. *PDC solar geysers*. [online] Available at: <<http://www.pdc solar.co.za/>> [Accessed 3 August 2011]

STATISTICS SOUTH AFRICA. 2011. *Mid-year population estimates, 2011*. [online] Available at: <<http://www.statssa.gov.za/publications/statsdownload.asp?PPN=P0302&SCH=4986>> [Accessed 3 August 2011]

SOUTH AFRICAN INSTITUTE OF STEEL CONSTRUCTION. 2011. Advantages of steel. [online] Available at: <[http://saisc.co.za/saisc/about\\_steel.htm](http://saisc.co.za/saisc/about_steel.htm)> [Accessed 10 November 2011]

UNIVERSITY OF CANBERRA. 2009. *What is cultural heritage?*. [online] Available at: <<http://www.canberra.edu.au/centres/donald-horne/cultural-heritage/what-is>> [Accessed 3 October 2011]

VICTORIA AND ALBERT ART MUSEUM. 2011. *Art Deco study guide*. [online] Available at: <<http://www.vam.ac.uk/content/articles/a/study-guide-art-deco>> [Accessed 11 July 2011]