

Jankel Nieuwoudt

High Street Abattoir

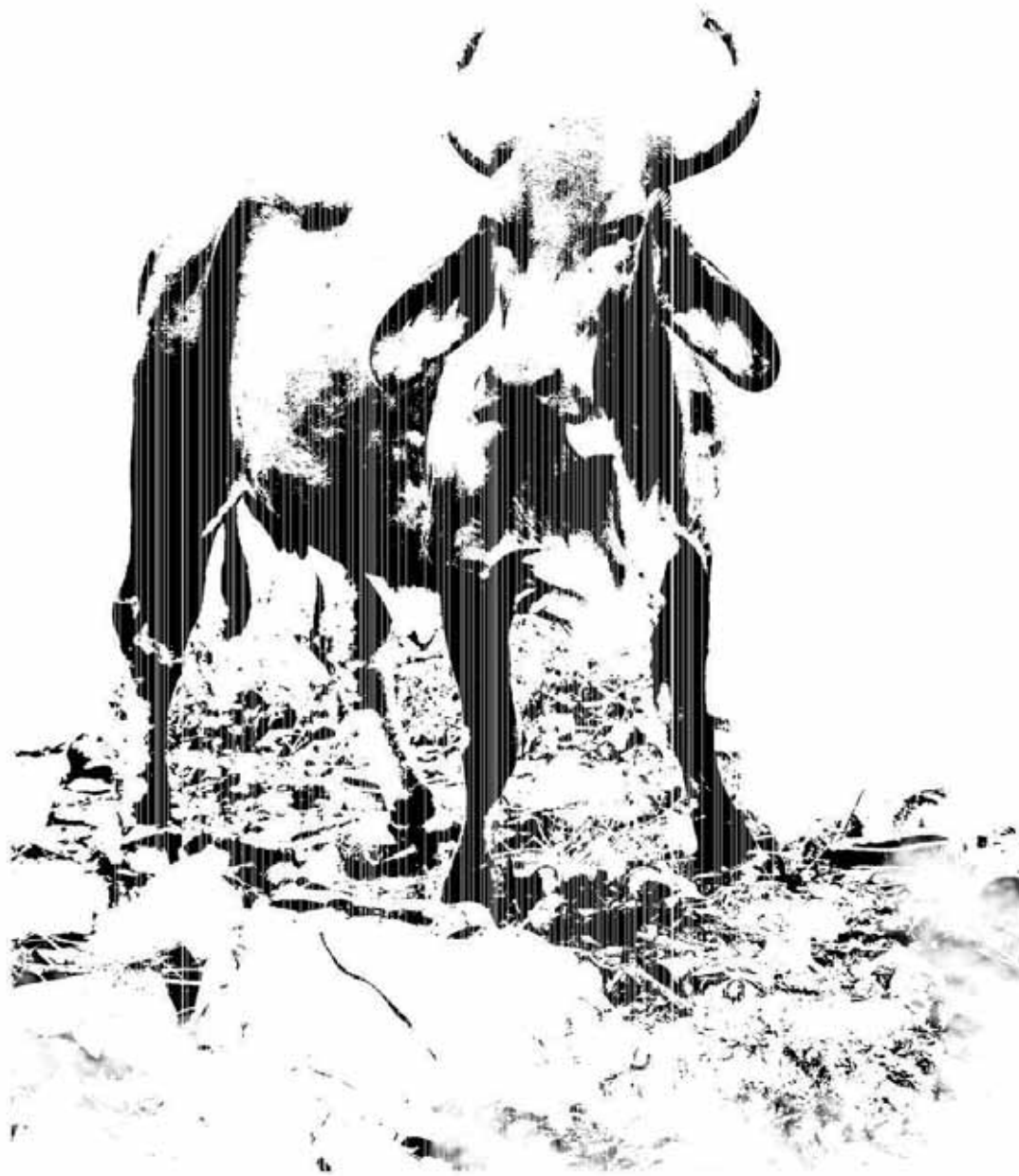

A New Interface for Architecture of Industry Mediated Through a Public Abattoir

Jankel Nieuwoudt

High Street Abattoir

A New Interface for Architecture of Industry Mediated Through a Public Abattoir

Submitted in fulfilment of part of the requirement for the degree of Magister in
Architecture (Professional) in the Faculty of Engineering, The Built Environ-
ment and Information Technology.

University of Pretoria

Study Leader: Arthur Barker

Course Coordinator: Jacques Laubscher

BUILDING

Address: Eerste Fabrieke Station Precinct

Function: Bovine Abattoir

Research Field: Environmental Potential

DISCOVERY

This dissertation follows a path of discovery starting with one problem and unearthing the next in the pursuit of a solution. The dissertation begins by identifying the static nature of industrial architecture and from there follows a series of investigations which finally leads to the selection of a site and the generation of a program. The chosen site is in Mamelodi at the Eerste Fabrieke Station on the site of the old distillery and Consol Glass Works, dating back to 1890. The programme is an abattoir within the proposed new urban framework by GAPP. An abattoir in the context of a high street will test the hypothesis of a new interface between industry and the public realm on an acute level. The resulting design will attempt to develop a new interface for architecture of industry for even the most gruesome of processes .

The sun is high up in the sky and I'm in my car

Drifting down into the abattoir

Do you see what I see dear?

The air grows heavy. I listen to your breath

Entwined together in this culture of death

Do you see what I see dear?

Mass extinction, darling, hypocrisy

These things are not good for me

Do you see what I see dear?

Lyrics from "Abattoir Blues" by Nick Cave and the Bad Seeds

20 September 2004

CONTENTS

	Background of Mamelodi	p. 78 - 79
	Graphic Development of Mamelodi	p. 80 - 83
Chapter Five - Urban Design		
	Context - Urban Critique: Mind the GAPP	p. 86 - 87
	GAPP Proposal for Study Area	p. 88 - 89
	Strategies and Mechanisms	
	Framework Proposal - Introduction	p. 90
	Framework Brief	p. 90
	Historical Development of Site	p. 90 - 93
	Framework Proposal	
	Part 1: Initiation	p. 96 - 97
	Part 2: Activation	p. 98 - 99
	Part 3: Invasion	p. 100 - 115
Chapter Six - Precedents		
	Form One: Patkau - Seabird Island School	p. 118 - 121
	Form Two: Zaha Hadid - Landscape Formation One	p. 122 - 123
	Function One: Arkitema k/s - Abattoir in Horsens, Denmark	p. 124 - 125
	Function Two: BVN Consulting Engineers - Rietvlei Abattoir	p. 126 - 129
	Context: Jean Nouvel - Quai Branly Museum	p. 130 - 133
	Technology: Mark Goddard - Abattoir at Cranswick	p. 134 - 135
Chapter Seven - Programmatic Intentions and Legislation		
Chapter Eight - Design Development		
	Design Informants	p. 146
	Part 1: The Site	p. 146 - 149
	Part 2: Concept	p. 150 - 153
	Planning	p. 156 - 163
	Sectional Development	
	Part 3: Section Concept	p. 166 - 175
	Application of Regenerative Principles	p. 176 - 177
	Final Planning	p. 178 - 187
Chapter Nine Technical Investigation		
	Stereotomy - The Slaughter Pit	p. 190 - 193
	Tectonics - The Frame	p. 194 - 203
	The Skin	p. 204 - 209
	Solar Study	p. 210 - 211
	Systems Summary	p. 212 - 213
Chapter Ten - Conclusion		
Chapter Eleven - Drawings & Model		
References		
List of figures		p. 6 - 10
Preface		p. 14 - 15
Chapter One - Introduction		
	Problem Statement	p. 18
	Hypothesis	p. 18
	Sub Problems	p. 18 - 19
	Objective	p. 20
	Delimitations	p. 20
	Assumptions	p. 20 - 21
Chapter Two - Programme		
	Red Meat Production - Introduction	p. 24
	Part 1: Human Health	p. 24
	Part 2: Who to Feed?	p. 25 - 26
	Part 3: Water Scarcity	p. 26
	Part 4: Environmental Impact	p. 26
	Part 5: The Welfare of the Animals	p. 26
	The Abattoir - Introduction	p. 30
	The history of the Abattoir	p. 30 - 32
	Shifting Sensibilities	p. 36 - 37
	The Call for the Animal Voice to be Heard	p. 40 - 41
	Defining the New Abattoir - The five Freedoms	p. 42
Chapter Three - Theory		
	A Required Change for a Static Typology	p. 46 - 47
	The 3rd Industrial Revolution	p. 48 - 51
	Heritage: Recycling History and Memory	p. 52 - 55
	Beyond Sustainability - Regenerative Architecture	p. 58 - 61
	Theoretical Synthesis	p. 62 - 63
Chapter Four - Context		
	Industrial Development in Pretoria - A Brief Overview	p. 66 - 67
	Setting - Site Selection Criteria	p. 68 - 69
	Project Location	p. 70
	Site Analysis	p. 70 - 77

LIST OF FIGURES

Fig - 0.1- Cover page [Source: digital image by author] _p 110

Fig - 0.2- This photograph is from Phil D's photographic collection of derelict industrial buildings [Source: www.Flickr.com] _p 12

Figure - 0.3 - Industrial Wasteland in Duisburg Nord - [Source: Curulli, 2006, p.38] _p 15

Figure - 0.4 - Abandoned Industrial space in Pretoria West [Source: Author] _p 15

Fig - 1.1- This photograph is from Phil D's photographic collection of derelict industrial buildings [Source: www.Flickr.com] _p 16

Figure - 1.2 - Visual breakdown of Industrial Typology - [Source: Author] _p 19

Figure - 1.3 - How to solve the inherent problems with industrial typology [Source: Author] _p 21

Fig - 2.1 -Photo of abattoir worker guiding a carcass along the slaughter route [Source: Author] _p 22

Fig - 2.2 - The rising global meat consumption [Source: Author]. Information from www.ciwf.org _p 24

Fig - 2.3 - Meat consumption in South Africa over the past 14 years. [Source: www.statssa.gov.za] _p 26

Fig - 2.4 - Comparative agricultural land use efficiencies - [Source: Author]. Information from www.ciwf.org _p 27

Fig - 2.5 - Meat consumption in South Africa over the past 14 years in graph form [Source: www.statssa.gov.za] _p 27

Fig - 2.6 - Brian Hill, Still from 'Slaughterhouse: The Task of Blood', Century Films, 2005 [Source: Antennae.org.uk] _p 28

Fig - 2.7 - A Relationship can be established between Mechanical and Ritual Slaughter _p 29

Fig - 2.8 - Illustration by David Lupton. The illustration expresses the hyper separated state between man and nature [Source: http://davidlupton.blogspot.com/2009/05/two-new-abattoir-blues-illustrations.html] _p 30

Fig - 2.10- Formalised ritual slaughter - no hygienic considerations.

Fig - 2.11- Makeshift hoist for ritual slaughter [Source: McCrindle, C. (2004)] _p 33

Fig - 2.12- Backyard ritual slaughter [Source: McCrindle, C. (2004)] _p 33

Fig - 2.13- Cattle roam the streets in townships eating whatever they can find [Source: McCrindle, C. (2004)] _p 33

Fig - 2.14- Makeshift transport can cause death or serious injury to animals [Source: McCrindle, C. (2004)] _p 33

Fig - 2.15- Photo of cattle hanging from the roof during the bleeding process [Source: Author] _p 34

Fig - 2.16 - Digital image (Compiled By Author) depicting a required public discourse [Source: http://www.coolorama.com/wp-content/uploads/2010/08/woman-screaming.jpg&imgrefurl=http://www.coolorama.com/featured-articles/lame-anti-halloween-fascist-boos-said-holiday/attachment/woman-screaming, http://www.dogboarding.kennelseek.com/wp-content/uploads/2011/01/woman-thinking.jpg&imgrefurl=http://www.dogboarding.kennelseek.com, www.iging.com/laotse/LaotseE.htm] _p 37

Fig - 2.17 - Cover of the Antennae online magazine issue dealing with the death of animals in art [Source: Antennae.org.uk] _p 38

Fig - 2.18 - Photograph of an abattoir worker cleaning the heads of the cattle [Source: Author] _p 39

Fig - 2.19 - Conceptual figure showing the re-establishment of the non-human in human minds [Compiled by author, Source: photograph by author, Cow illustration: www.stockphoto.com] _p 41

Fig - 2.20 - Photograph by author of cattle waiting in pens prior to slaughter [Source: Author] _p 43

Fig - 3.1- This photograph is from Phil D's photographic collection of derelict industrial buildings [Source: www.Flickr.com] _p 44

Figure - 3.2 (Right)- Photograph by Ester Havlova from her "Fragments" collection [Source: Scan from collection] _p 47

Figure - 3.3 - The Third Industrial Revolution [Source:] _p 49

Figure - 3.4 - The making of the Third Industrial Revolution [Compiled by author, Source:] _p 51

Figure - 3.5 - This photograph is from Phil D's photographic collection of derelict industrial buildings [Source: www.Flickr.com] _p 53

Figure - 3.6 - Photograph of underground bunkers on site [Source: Author] _p54

Fig - 3.7- Photograph by author _p 56

Figure - 3.8 - Article from the Guardian August 29, 2006 [Source: www.guardian.co.uk] _p59

Figure - 3.9 - Regenerative design - A balance between natural and man made ecosystems [Source: www.hcu-hamburg.de: www.hcu-hamburg.de] _p61

Figure - 3.10 - "The Ecopolis" - Diagram of how regenerative cities work [Source: www.hcu-hamburg.de: www.hcu-hamburg.de] _p61

Fig - 4.1- Photograph of historical remains on site. These buildings where the old foreman's homes [Source: Author] _p64

Figure - 4.2 - Rail and Road network in Pretoria 1955 [Source: Unknown] _p 67

Figure - 4.3 - Witwatersrand Industrial complex [Source: Unknown] _p 67

Figure - 4.4 - Pretoria West Power Station initiated industrial development [Source: Pretoria, Felstar Publishing] _p 67

Figure 4.5 - Image from 1955 - Pretoria and Industry [Source: Pretoria, Felstar Publishing] _p 67

Figure - 4.6 - Africa with South Africa as indicated [Source: digital image by author] _p 68

Figure - 4.7 - South Africa with Tshwane as indicated [Source: digital image by author] _p 68

Figure - 4.8 - City of Tshwane with Mamelodi as indicated [Source: digital image by author, Base map from www.COT.gov.za] _p 68

Figure 4.9 - Aerial photo of the Eerste Fabriek Precinct [Source: UP collection, Geography] _p 69

Figure - 4.10 - Photograph of cattle grazing in large amounts of rubbish found along the streets of Mamelodi [Source: Author] _p 71

Figure - 4.11 - Aerial photograph of the Mamelodi Area [Source: digital image by author] base map [Source: UP collection, Geography] _p 72

Figure - 4.12 - Aerial photograph of the Eerste Fabrieke area [Source: digital image by author] base map [Source: UP collection, Geography] _p 74

Figure 4.13 - Heritage on site [Source: digital image by author] _p 76 - 77

Figure - 4.14 - Photograph of Mamelodi [Source: Author] _p 79

Figure - 4.15 - Layout prior to the establishment of Mamelodi [Source: J. Walker, G. v. (1991)] _p 80

Figure - 4.16 - Old Map of the original layout of Mamelodi (1961) [Source: J. Walker, G. v. (1991)] _p 80

Figure - 4.17 - Survey of built fabric (1970) [Source: J. Walker, G. v. (1991)] _p 81

Figure - 4.18 - Final Layout (1976) [Source: J. Walker, G. v. (1991)] _p 81

Figure - 4.19 - Timeline of important events in Mamelodi [Source: digital image by author], information source (Kaye, 1978. p 4-30.) _p 82-83

Figure - 5.1 - Photograph of cattle being processed in the Rietvlei Abattoir [Source: Author] _p 84

Figure - 5.2 - The Nodal development as proposed by GAPP [Source: GAPP Architects and Urban Designers] _p 87

Figure - 5.3 - Proposed node, activity spines and areas by GAPP [Source: GAPP Architects and Urban Designers] _p 87

Figure - 5.4 - Proposal for the chosen working area by GAPP [Source: GAPP Architects and Urban Designers] _p 89

Figure - 5.5 - GAPP proposes medium and high density housing for the chosen site and does not recognise the importance of the site [Source: GAPP Architects and Urban Designers] _p 89

Figure - 5.6 (Right)- 1937 Aerial photograph of the Eerste Fabrieke precinct indicating the first industrial complex [Source: UP collection, Geography] _p 90

Figure - 5.7 - Historical development of site [Source: digital image by author] _p 92

Figure - 5.8 - The topographical characteristics of the site - falling towards the Pienaars River [Source: digital image by author] _p 93

Figure - 5.9 - The urban proposal for the Eerste Fabrieke Precinct [Source: digital image by author] _p 94 - 95

Figure - 5.10 - Concept - Initiation [Source: digital image by author] _p 97

Figure - 5.11 - Conceptual render of nodes [Source: digital image by author] _p 97

Figure - 5.12 - Nodes placed strategically across site. Nodes determined by the historical development of the site [Source: digital image by author] _p 97

Figure - 5.13 - Business Incubation Centre in Pramtal, Austria by Spittelwiese Architekten [Source: http://www.hoermann.com] _p 98

Figure - 5.14 - Plan of Business Incubation Centre in Pramtal, Austria by Spittelwiese Architekten [Source: http://www.hoermann.com] _p 98

Figure - 5.15 - View to the south from the Eerste Fabrieke Station [Source: digital image by author] _p 98

Figure - 5.16 - Small Business Incubators placed on the nodes to initiate development [Source: digital image by author] _p 98

Figure - 5.17 - Concept - Activation [Source: digital image by author] _p 99

Figure - 5.18 - The Small Business Incubators indicated in red. Site indicated in orange [Source: digital image by author] _p 99

Figure - 5.19 - View across development looking east [Source: digital image by author] _p 100

Figure - 5.20 - Further development initiated by the Small Business incubators [Source: digital image by author] _p 100

Figure - 5.21 - Concept - Invasion [Source: digital image by author] _p 101

Figure - 5.22 - Further development indicated in black. Site indicated in orange [Source: digital image by author] _p 101

Figure - 5.23 - Concept - Appropriation [Source: digital image by author] _p 102

Figure - 5.24 - Further development between nodes as area becomes appropriated. Site indicated in orange [Source: digital image by author] _p 102

Figure - 5.25 - Final Conceptual render of development indicated the invasion level of development [Source: digital image by author] _p 103

Figure - 5.26 - The zoning is determined by neighbouring functions of Mamelodi and Nellmapius. A fine balance between light industry, housing and peri - urban agriculture is proposed [Source: digital image by author] _p 104 - 105

Figure - 5.27 - The existing love drive connection is proposed to be upgraded. A mixed mode transport spine is proposed to connect Mamelodi, Eerste Fabrieke and Nellmapius. This connection is to be characterised by wide sidewalks to facilitate pedestrians and cyclists [Source: digital image by author] _p 106 - 107

Figure - 5.28 - The chosen site is situated on the northern side of the Eerste Fabrieke precinct, edging the new high street. The site is bordered by love drive on the west and the proposed new heritage precinct on the south and east [Source: digital image by author] _p 108 - 109

Figure - 5.29 - Rendered perspective view looking east [Source: digital image by author] _p 110

Figure - 5.30 - Rendered perspective view looking north [Source: digital image by author] _p 111

Figure - 5.31 - Rendered perspective view looking east [Source: digital image by author] _p 112

Figure - 5.32 - Rendered perspective view looking south [Source: digital image by author] _p 113

Figure - 5.33 - Rendered perspective view of the heart of the development around the heritage square [Source: digital image by author] _p 114 - 115

Figure - 6.1 - Photograph of a abattoir worker leading a carcass down to the inspection area [Source: Author] _p 116

Figure - 6.2 - The heavy engineered timber post and beam construction [Source: Patkau Architects, The Monacelli Press, New York (2006)] _p 118

Figure - 6.3 - Ground floor plan [Source: Patkau Architects, The Monacelli Press, New York (2006)] _p 119

Figure - 6.4 - The building is organised around the porch with the bulk of the building situated on the northern side and connections to other community activities to the south [Source: Patkau Architects, The Monacelli Press, New York (2006)] _p 119

Figure - 6.5 (Above) - [Source: Patkau Architects, The Monacelli Press, New York (2006)] _p 120

Figure - 6.6 (Right) - [Source: Patkau Architects, The Monacelli Press, New York (2006)] _p 120

Figure - 6.7 - Sections indicating the changing nature of the roof structure [Source: Patkau Architects, The Monacelli Press, New York (2006)] _p 121

Figure - 6.8 (Right) - Plans and sections indicating how the building integrates into the natural landscape [Source: Zaha Hadid, www.zahahadid.com] _p 122

Figure - 6.9 - A path grows into a building and back into a path again [Source: Zaha Hadid, www.zahahadid.com] _p 123

Figure - 6.10 - A completely different aesthetic compared to the typical industrial sheds [Source: <http://www.hoermann.com>] _p 124

Figure - 6.11 - Courtyards are introduced between administrative and production spaces as depicted in this image [Source: <http://www.hoermann.com>] _p 125

Figure - 6.12 - An image from the Danish Crown website depicting the automation of the processing of the pigs [Source: <http://www.danishcrown.com>] _p 125

Figure - 6.13 - A wall of carcasses meets you on entrance [Source: Author] _p 126

Figure - 6.14 - The massing of the site. Administrative functions are scattered across the site [Source: digital image by author] _p 127

Figure - 6.15 - A large amount of circulation space which is unused [Source: digital image by author] _p 127

Figure - 6.16 - Rietvlei Abattoir Plan [Source: BVN Consulting Engineers] _p 127

Figure - 6.17 - The cattle is hooked and hoisted after it has been stunned [Source: Author] _p 128

Figure - 6.18 (Above) - A row of carcasses hang as the man skins them [Source: Author] _p 129

Figure - 6.19 (Below) - The Roof structure with all its rails and systems [Source: Author] _p 129

Figure - 6.20- Site Plan indicating how the building grows out of the old buildings [Source: Jean Nouvel, www.attelierjeannouvel.com] _p131

Figure - 6.21- Photograph from the Eiffel Tower depicting the greater context of the building [Source: Jean Nouvel, www.attelierjeannouvel.com] _p131

Figure - 6.22 (Above) - Mezzanine floor plan [Source: Jean Nouvel, www.attelierjeannouvel.com] _p132

Figure - 6.23 (Below) - The envelope of the above ground exhibition space consists of a series of adjustable louvres to control the light inside the exhibition. The site is also heavily planted with trees converting a Parisian garden into a forest with a museum hidden inside [Source: Jean Nouvel, www.attelierjeannouvel.com] _p132

Figure - 6.24 - Section depicting the underground exhibition spaces and the relationship to the street [Source: Jean Nouvel, www.attelierjeannouvel.com] _p133

Figure - 6.25 - Section depicting the above and underground exhibition spaces and the building's contextual relations to the surrounding streets [Source: Jean Nouvel, www.attelierjeannouvel.com] _p133

Figure - 6.26 - The existing building facade is continued but the new is characterised by large windows and a wall which is completely planted [Source: Jean Nouvel, www.attelierjeannouvel.com] _p133

Figure - 7.0 - Photograph of carcasses waiting to be inspected [Source: Author] _p 134

Figure - 7.1 - Mechanical slaughter versus ritual slaughter and the sequence of events [Source: digital image by author] _p 139

Figure - 7.2 - A detailed layout of abattoir processes [Source: Modernism, Movement and Meat: Reclaiming the Slaughterhouse ,Todd Satter (2008) www.toddsatter.com] _p 139

Figure - 7.3- Meat grading stamps prescribed by the Department of Agriculture [Source: Extract from Government Gazette No. 26779, 2004 09 17, Department of Agriculture] _p 141

Figure - 7.4- A pie chart indicating the different types of electrical consumption within a typical abattoir [Source: www.ai-group.com.au.] _p 141

Figure - 7.5 - Example waste water treatment - Deoiling IC-SEP* System [Source: www.york.com] _p 143

Figure - 7.6- Example of waste water treatment - Solids Removal IC-SEP* System [Source: www.york.com] _p 143

Figure - 7.7- Waste heat recovery system [Source: www.york.com] _p 143

Figure - 8.1 - Photograph of a floor drain in the Rietvlei Abattoir [Source: Author] _p 144

Figure - 8.2- Transparency VS Process - Early conceptualisation of organisational method [Source: digital image by author] _p 147

Figure - 8.3- Rhythm - Establishing a sequence of hiding and showing the abattoir to the high street [Source: digital image by author] _p 147

Figure - 8.4- Area plan with important contextual elements [Source: digital image by author] _p 148

Figure - 8.5- Site plan with important contextual elements [Source: digital image by author] _p 149

Figure - 8.6- Conceptual photograph - A linear process (as shown by the light) with relationships established over it [Source: digital image by author] _p 150

Figure - 8.7- Conceptual diagram. A reinterpretation of fig - 8.6. [Source: digital image by author] _p 151

Figure - 8.8- Conceptual model one "Connections" - View looking west - Constant interaction needs to be established [Source: digital image by author] _p 152

Figure - 8.9- Conceptual model one "Connections" - View looking south at the high street interface [Source: digital image by author] _p 153

Figure - 8.10- Conceptual model one "Connections" - Plan view [Source: digital image by author] _p 153

Figure - 8.11- Early conceptual render and massing exercise [Source: digital image by author] _p 154

Figure - 8.12- Conceptual diagram of important connections. A linear process is established with connections to the heritage on the south western edge being identified [Source: digital image by author] _p 156

Figure - 8.13- Conceptual diagram exploring further relationships between connecting elements and exploring separate pavilions that interact with the high street [Source: digital image by author] _p 156

Figure - 8.14- Sketch showing spatial exploration of connecting elements. The possibility of courtyards between these elements can allow for south light to enter and create views out of building, aiding the humanisation of the space [Source: digital image by author] _p 157

Figure - 8.15- A more detailed look at the connecting elements - possibilities of creating recreational spaces for employees, entrances and other employee orientated programming [Source: digital image by author] _p 157

Figure - 8.16- A Sequence of early diagrams explored the design of the process. Firstly the linear process with spaces clipping onto it was developed. The line at the top represents the unscripted public process [Source: digital image by author] _p 158

Figure - 8.17 - Secondly the process is to return parallel to itself ,so that the bottom half of the site can be utilised and connected with the heritage. [Source: digital image by author] _p 158

Figure - 8.18 - The process was then defined - The slaughter process will be parallel to and against the high street with the returning line comprising of the meat processing [Source: digital image by author] _p 158

Figure - 8.19- A layered interface - Early conceptual diagram illustrating a multiple layered facade with which the public can engage on the level they wish. This was later translated into the output pavilion model (refer to fig 8.18) [Source: digital image by author] _p 158

Figure - 8.20 - Output Pavilions - Conceptual Sketches - These pavilions establish a platform for engagement with the public. The closed space is to be conceived as the space where the animal by-products gets sanitised (so that it can be processed outside without posing any hygienic harm), the in between spaces are based on the spatial quality found in harbours where fresh fish gets processed and sold directly to the public [Source: digital image by author] _p 159

Figure - 8.21- Further diagrammatic exploration of the spatial potential of the linear process and the connecting elements attached to it. A clear form and general organisation starts to develop [Source: digital image by author] _p 159

Figure - 8.22- Concentrating a process from a natural environment into a processed environment. Conceptual diagram [Source: digital image by author] _p 160

Figure - 8.23 & 24- Diagrammatic exploration of slaughter pit plan. The diagrams explore the concentration of the process. As spatial requirements become less at the end of the slaughter line the pit narrows. This results in a steeping northern edge which translates as the wall separating the public from the slaughter. These steps create places for the pavilions to clip onto [Source: digital image by author] _p 160

Figure - 8.25- Final conceptual sketch of lower ground floor plan / slaughter pit plan. The plan starts with the animals entering the pit via a Temple Grandin curved cattle chute. This leads the cattle to the lairage area which is flanked on the southern side by the waste water recycling plant. From here they enter the CO2 knock box. After stunning, they never touch the pit floor again, only blood and viscera come into contact with the pit floor from there on [Source: digital image by author] _p 160

Figure - 8.26- Conceptual 3 D render of the slaughter pit space. This view looks east down the pit and this is the view the cattle will have from the lairage. Raised working platforms alongside the pit is where the workers will be situated and they will slaughter the cattle as they hang from the roof. Blood, viscera and water will flow into the pit where it is collected and reticulated to the waste water recycling area. The pit is designed as a hard wearing container, catching all waste and ensuring it gets recycled and processed [Source: digital image by author] _p 161

Figure - 8.26 - Conceptual model two "Form" - Plan view [Source: digital image by author] _p 162

Figure - 8.27 - Conceptual model two "Form" - View looking east [Source: digital image by author] _p 163

Figure - 8.28 - Conceptual model one “Form” - View looking west [Source: digital image by author]_p 164

Figure - 8.29 - Conceptual render of 3 dimensional development of the tectonics of the structure [Source: digital image by author]_p 164

Figure - 8.30 - Conceptual 3 dimensional render [Source: digital image by author]_p 165

Figure - 8.31 - Early conceptual diagram (long section) depicting the recessed slaughter pit with the roof floating above [Source: digital image by author]_p 166

Figure - 8.32 - Section concept diagram depicting the three planes and their respective functions [Source: digital image by author]_p 168

Figure - 8.33 - Cross section explorative sketch [Source: digital image by author]_p 169

Figure - 8.34 - Cross section explorative sketch [Source: digital image by author]_p 169

Figure - 8.35 - Cross section explorative sketch [Source: digital image by author]_p 169

Figure - 8.36 - Further exploration of the building in section and the separation of levels [Source: digital image by author]_p 170

Figure - 8.37 - Further development [Source: digital image by author]_p 170

Figure - 8.38 - Typical cross section through slaughter pit beyond the output pavilion - [Source: digital image by author]_p 171

Figure - 8.39 - Light explored on section [Source: digital image by author]_p 171

Figure - 8.40 - Section through chimney stack part of roof. This model is to be repeated four times throughout the building with the section shown in fig. 8.35 to connect these elements [Source: digital image by author]_p 171

Figure - 8.41 - Typical Section model which is to be repeated four times along the process at each output pavilion [Source: digital image by author]_p 172 - 173

Figure - 8.42 - Typical Section Model [Source: digital image by author]_p 174 - 175

Figure - 8.43 - Basement Plan [Source: digital image by author]_p 178 - 179

Figure - 8.44 - Ground Floor Plan [Source: digital image by author]_p 180 - 181

Figure - 8.45 - Service Floor Plan [Source: digital image by author]_p 182 - 183

Figure - 8.46 - Early 3D image of the building, view looking north. The building grows from the southern edge with the roof floating above the new ground plane [Source: digital image by author]_p 184

Figure - 8.47 - Above - 3D of high street with the repetitive pavilion model. The public spaces in between start to develop [Source: digital image by author]_p 185

Figure - 8.48 - 3D view from above depicting the entire building form and its connections to all the edges of the site [Source: digital image by author]_p 186

Figure - 8.49 - 3D view of meat market located on the north - eastern edge of the site [Source: digital image by author]_p 187

Figure - 8.50 - Close up 3D view of the processing pavilions [Source: digital image by author]_p 187

Figure - 9.1 - Photograph of the roof in Rietvlei Abattoir depicting the amount of structure and technology housed in it [Source: Author]_p 188 - 189

Figure - 9.2 - Early conceptual diagrams and sketches [Source: Author]_p 190

Figure - 9.3 - Above - Detail of work platform and the pit wall, illustrating the detailing around water entering the structure [Source: digital image by author]_p 191

Figure - 9.4 - Below - 3D section render of the slaughter pit and its components [Source: digital image by author]_p 191

Figure - 9.5 - 3D Detail of the work platform showing the pit, its components and how the water enters [Source: digital image by author]_p 192

Figure - 9.6 - Above - Detail of the retaining wall on the northern side of the slaughter pit [Source: digital image by author]_p 193

Figure - 9.7 - Below - 3D section render of the slaughter pit and the connection of the processing spaces on top of it [Source: digital image by author]_p 193

Figure - 9.8 - Early conceptual sketches of the roof [Source: digital image by author]_p 194

Figure - 9.9 - Above - Technical section through the slaughter pit [Source: digital image by author]_p 195

Figure - 9.10 - Below - 3D section render of the portal frame roof over the slaughter pit [Source: digital image by author]_p 195

Figure - 9.11 - Below - Image of explorative model built of the roof structure [Source: Author]_p 196

Figure - 9.12 - Opposite - Image of explorative model built of the roof structure [Source: Author]_p 197

Figure - 9.13 - Image of explorative model built of the roof structure [Source: Author]_p 197

Figure - 9.14 - Below - Image of explorative model built of the roof structure [Source: Author]_p 197

Figure - 9.15 - Sketches exploring the chimney and its components [Source: Author]_p 198 - 199

Figure - 9.16 - 3D Detail of final chimney, its components and materials [Source: digital image by author]_p 200

Figure - 9.17 - 3D Exploded detail of the chimney and its components [Source: digital image by author]_p 201

Figure - 9.18 - 3D Section render of the frame with the chimney structure extending from it [Source: digital image by author]_p 201

Figure - 9.19 - Above - 3D exploded detail of the wall, the portal frame and its components [Source: digital image by author]_p 202

Figure - 9.20 - “Sound Cell”, Diagrams of the acoustic principles the block uses to absorb sound [Source: www.fent.com]_p 202

Figure - 9.21 - Above - 3D Section render of the frame, system floors and the wall opposing the high street [Source: digital image by author]_p 203

Figure - 9.22 - Below - 3D Section render of the systems added [Source: digital image by author]_p 203

Figure - 9.23 - Below - 3D Detail of the roof connection on the southern side to the concrete upstand [Source: digital image by author]_p 204

Figure - 9.24 - Opposite - Technical Section A-A, a cross section through the slaughter pit and the roof at the chimney [Source: digital image by author]_p 205

Figure - 9.25 - 3D section render of the module with the Widespan sheeting added [Source: digital image by author]_p 205

Figure - 9.26 - Detail of roof connection to the concrete structure [Source: digital image by author]_p 206

Figure - 9.27 - Above - The composition of the green roof [Source: digital image by author]_p 207

Figure - 9.28 - 3D Section render of the processing pavilion with the Vitraclad panels on the side [Source: digital image by author]_p 207

Figure - 9.29 - Right - Plan of the high street edge of the abattoir with the pavilions and its activities in between [Source: digital image by author]_p 208

Figure - 9.30 - Above - The final module with the layered public interface. The space is to be freely appropriated by the public [Source: digital image by author]_p 209

Figure - 9.31 - Below - View from eye level of the final pavilion module [Source: digital image by author]_p 209

Figure - 9.32 - Spring Equinox [Source: digital image by author]_p 210

Figure - 9.33 - Summer Solstice [Source: digital image by author]_p 210

Figure - 9.34 - Autumnal Equinox [Source: digital image by author]_p 211

Figure - 9.35 - Winter Solstice [Source: digital image by author]_p 211

Figure - 9.36 - Systems indicated on the ground floor plan [Source: digital image by author]_p 212 - 213

Figure - 11.1 - Site Plan (By Author).

Figure - 11.2 - Basement / Slaughter Pit Plan (By Author).

Figure - 11.3 - Ground Floor Plan (By Author).

Figure - 11.4 - Systems Floor Plan (By Author).

Figure - 11.5 - Section A-A (By Author).

Figure - 11.6 - Section B-B (By Author).

Figure - 11.7 - High Street Elevation (By Author).

Figure - 11.8 - 3 Dimensional View Looking West - The linear slaughter process runs parallel to the high street, in constant interaction through the output pavilions (By Author).

Figure - 11.9 - 3 Dimensional View Looking North West - The abattoir grows out of the ground, anchored by the heritage on the south (By Author).

Figure - 11.10 - Dimensional View Looking North East - The output pavilions area colour coded according to what is happening inside (By Author).

Figure - 11.11 - 3 Dimensional View of the The Outdoor Processing and Vendor and Trading Areas on the High Street (By Author).

Figure - 11.12 - 3 Dimensional View of the High Street and the Meat Market (By Author).

Figure - 11.13 - 3 Dimensional Interior View of the Lairage Area which is Open for Public viewing to the Top (By Author).

Figure - 11.14 - 3 Dimensional View of the of Abattoir Entrance for the employees. From here the Building Grows out of the Ground Establishing another Public plane (By Author).

Figure - 11.15 - 3 Dimensional Interior View of the Processing Spaces with a view Out Onto the Courtyards (By Author).

Figure - 11.16 - 3 Dimensional Interior View of the Slitting Area and Bleeding Pit on the Pit Floor (By Author).

Figure - 11.17 - 3 Dimensional Interior View of the Carcasses coming out of the Hoisting area to the Bleeding Pit (By Author).

Figure - 11.18 - 3 Dimensional Interior View of the Evisceration Area (By Author).

Figure - 11.16 - 3 Dimensional Interior View of the Slitting Area and Bleeding Pit on the Pit Floor (By Author).

Figure - 11.17 - 3 Dimensional Interior View of the Carcasses coming out of the Hoisting area to the Bleeding Pit (By Author).

Figure - 11.18 - 3 Dimensional Interior View of the Evisceration Area (By Author).

Figure - 11.22 - 3 Dimensional Detail - Portal Frame and Green Roof Junction (By Author).

Figure - 11.23 - 3 Dimensional Detail - Green Roof Construction (By Author).

Figure - 11.24 - Detail 03 - 04 - Portal Frame / Roof Detail (By Author).

Figure - 11.25 - Details 7, 8, 9 - Chimney Details (By Author).

Figure - 11.26 - Image 01 (By Author).

Figure - 11.27 - Image 02 (By Author).

Figure - 11.28 - Image 03 (By Author).

Figure - 11.29 - (Left) Image 04 (By Author).

Figure - 11.30 - Image 05 (By Author).

Figure - 11.31 - Image 06 (By Author).

Figure - 11.32 - Image 07 (By Author).

Figure - 11.33 - Image 08 (By Author).



Fig - 0.2
This photograph is from
Phil D's photographic col-
lection of derelict indus-
trial buildings. All photos
Available on www.Flickr.com

PREFACE

The 20th century was characterised by a rapid technological development. An industrial economy lasted for 250 years and has been superseded by a service economy which is expected to last for about 60 - 80 years. After this, the knowledge economy will take over, which will last for no more than 50 years before an economy based on bio-sciences will replace it (Jenkin & Worthington, 1996, p. 85).

Economies last for shorter periods of time as technology forms the driver for change and as technologies progress at an exponential rate, so do the economies surrounding it. Mass production has been replaced with miniaturisation or clever production of goods and industrial production no longer needs the spatial requirements or production lines it used to (Kellenberger, 2007, p. 5). This has caused a mass exodus from industrial production areas with the change of economy and resulted in deserted urban landscapes fortifying urban centres.

“Industrial spaces are mentally exterior in the physical interior of the city”

(Curulli, 2006, p. 32)

The industrial architecture that remains is a collection of static, mono-functional, disconnected edifices designed as flexible containers that never transcended the change of economy or context and after periods of extreme use bear witness to human progression (Curulli, 2006, p. 36).

Deserted industrial sites suffer from not only a physical but also a *perceived* state of environmental problems due to their lack of physical fertility. Most of the deserted industrial sites have existing infrastructures, are well connected to transport and are well positioned in relation to the business sector, but are overlooked

by local developers due to the stigma associated with post industrial sites and processes (Burke, [2002], p. 1).

Irene Curulli describes industrial wastelands as absent from the city’s circuit and productive structure and places which are foreign to the urban system (2006, p. 36). With the desertion of industrial areas (damaged by human activity) massive sites have become available for urban growth. The size and scale of these sites offer numerous avenues for urban development and its lack of function offers the designer carte blanche for experimentation.

Industrial development is not something of the past, especially in developing countries such as South Africa. The only difference now is that the nature of industry has changed and therefore the architectural typology to house it requires a drastic change to limit the ills of the past. With the change of industrial typology comes the opportunity to address the spatial, environmental and social problems of industrial architecture.

The dissertation investigates an interface between industrial architecture, the public realm and formal and informal programmatic functions mediated through an urban abattoir. Further, the dissertation examines the occupation of a deserted industrial site and revival thereof through new light industrial programming.

The proposal focusses on the rejuvenation of the abattoir as a ritualistic and cognisant process and the contemporary application of the industrial typology mediated through regenerative architectural principles and sustainable technologies.

A new public interface is explored to reconnect industrial architecture and industry to the “*urban surface*”, avoiding the mis-

takes of the past and preserving the future of the site and its surrounding context.

The final design ameliorates the deserted wasteland condition by connecting the new abattoir to the industrial heritage of the site. The resultant design is an urban abattoir which interacts and expresses itself at various scales whilst always representative of the processes housed. The design creates a dialogue be-

tween the public and the abattoir by adopting the methodology of reclaiming the entire animal carcass as done in South African ritual slaughter. The design incorporates numerous sustainable systems to reduce the waste found in abattoirs.

The project reconnects the contemporary abattoir to the productive urban network and emphasises the importance of architecture in the regeneration of a building typology.



Figure - 0.3 - Industrial Wasteland in Duisburg Nord - (Curulli, 2006, p.38)

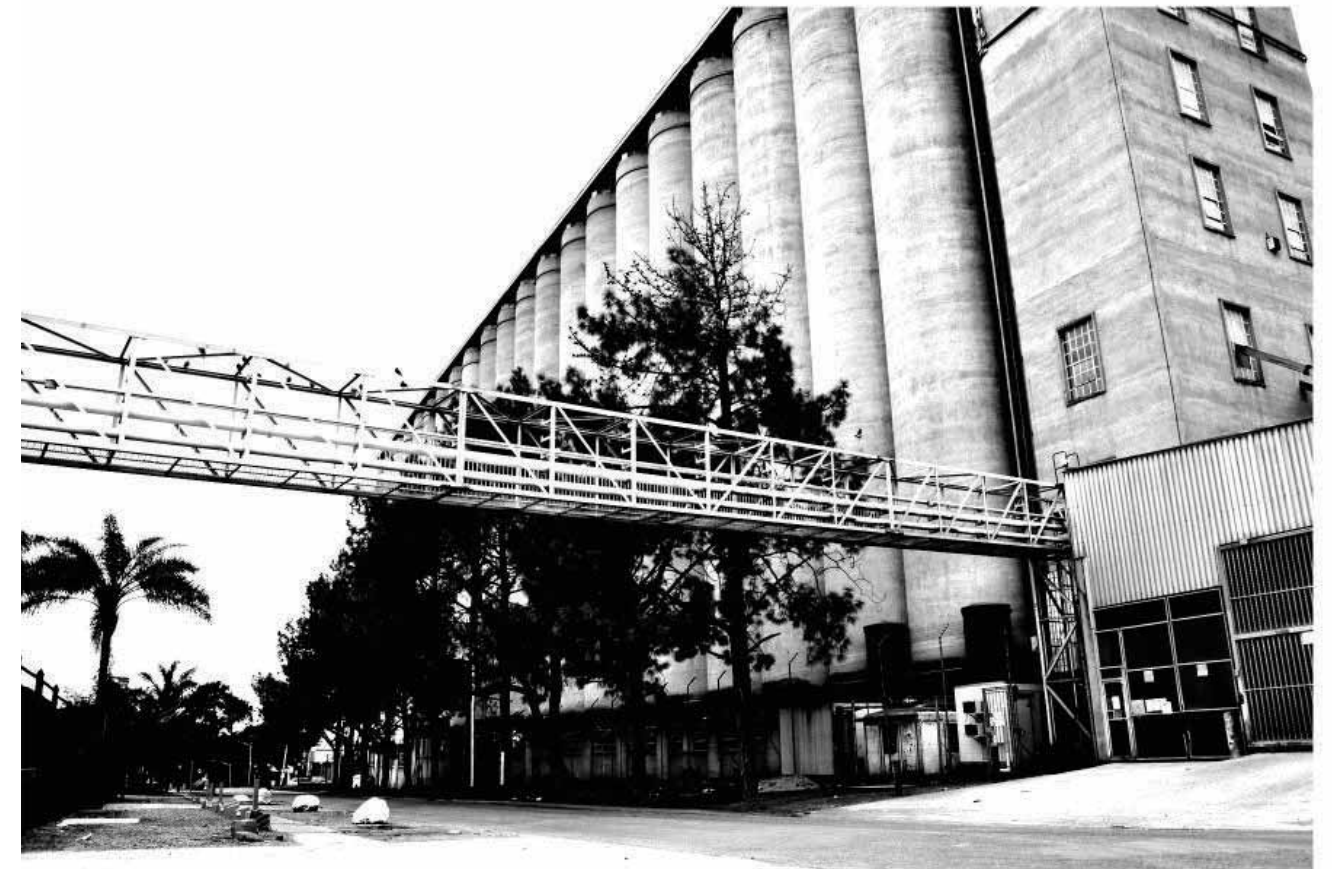

Figure - 0.4 - Abandoned Industrial space in Pretoria West. (By Author)

1.1 ?



Fig - 1.1
This photograph is from
Phil D's photographic col-
lection of derelict indus-
trial buildings. All photos
Available on www.Flickr.com

INTRODUCTION

Problem Statement

The Problem:

Industrial and urban development has and continues to develop on opposite poles of the city, (*Industrial development referring to areas of production and urban development referring to commercial and residential development*). This is causing industrial wastelands to become even more disconnected from the urban network, making industrial wastelands black holes in the mental maps of urban areas (Curulli, 2006, p. 38).

The architecture of industrial typology transformed to the architecture of economy during industrialisation in the late 19th century due to the speed of erection and flexibility it required and materialised as large sheds with no formal expression of processes housed. The industrial typology has therefore never been regarded as an architecture that contributed much to architectural history and was and still is regarded as somewhat of an engineering exercise (Winter, 1970, p. 7).

The Question:

How should new industrial development on deserted industrial brownfield sites be combined with new urban development initiatives to explore the relationship between industrial praxis and the public realm?

Hypothesis:

With the recent shift to a sustainable paradigm, the inherent spatial, environmental and social problems of the industrial typology can be addressed by firstly solving the tri-pollution factor

(air, noise and light pollution) through new architectural technologies and environmentally conscious design. If/when these factors are solved, the building can become a more accessible architectural vehicle to address its immediate surroundings and reconnect to the productive urban network and the surrounding context.

A new typology can be formulated to integrate areas of production into areas of commerce and living, to create urban areas of diverse programmes which can reach equilibrium of complementary energy production and public concession.

Sub Problems:

What are the regenerative possibilities of new industrial development?

Can an architecture of production happen in a peri-urban context and enter a dialogue of constructive engagement with the public?

How can areas of large scale production create a humanised work environment?

How can new industrial development respond to or interact with existing heritage?

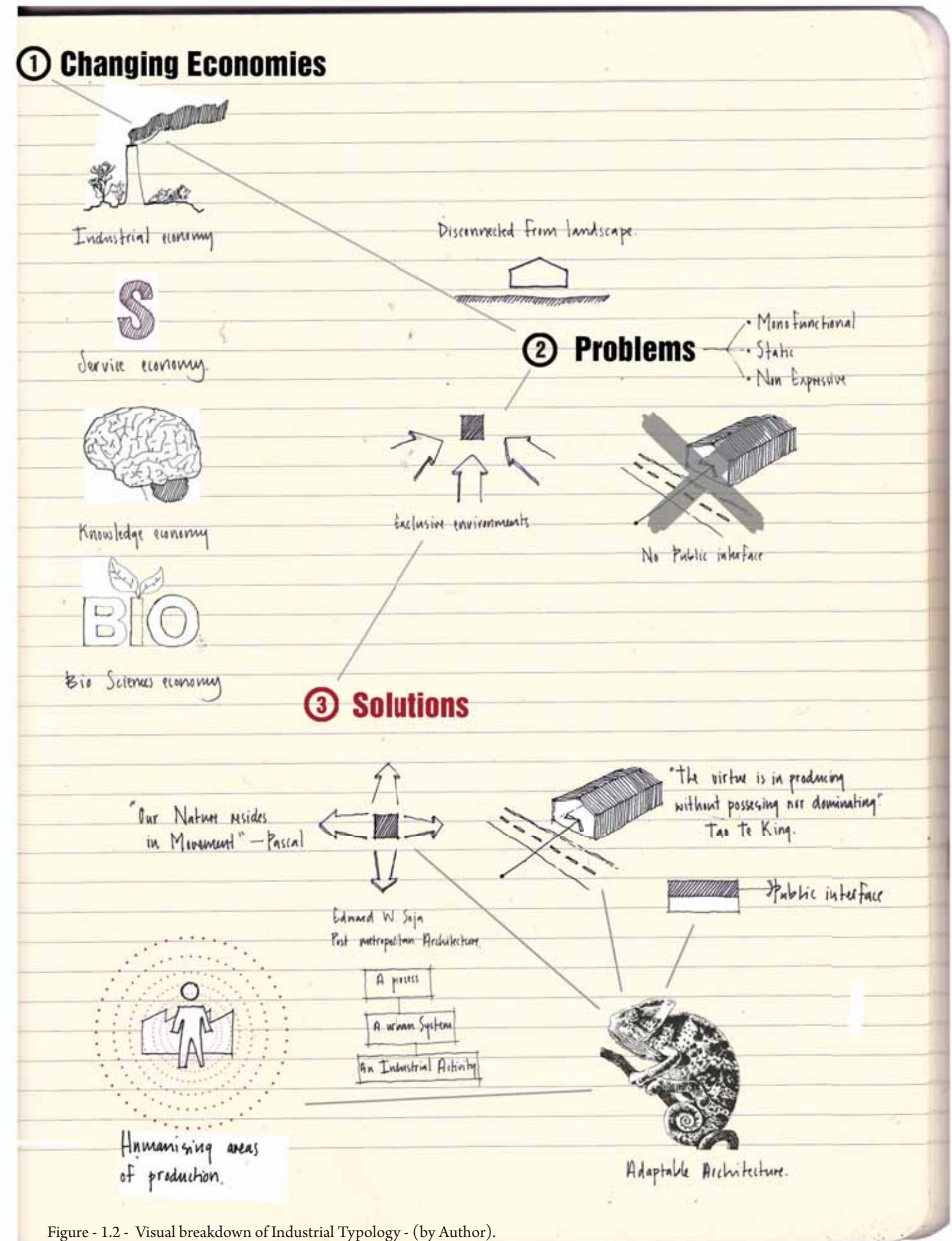

Figure - 1.2 - Visual breakdown of Industrial Typology - (by Author).

Objective

The objective of this dissertation is to investigate the spatial potential of urban industrial wastelands by using sustainable design principles in the design of places of production. By liberating industrial areas or areas of production from contamination and reconnecting them to the urban network, a new public interface between the industrial typology and the public realm can be investigated within the context of the Third Industrial Revolution.

Further, the dissertation will explore the temporal nature of industrial buildings to facilitate changing economies and contexts so that the architecture is not rendered useless as its function becomes obsolete. This will be done by designing a building within a new urban development initiative in Mamelodi, situated in the eastern precinct of the City of Tshwane, where the building will facilitate the growth of the new framework. The design will then have to adapt to the changing context of production to accommodate the context of the proposed high street development.

The chosen programme is an abattoir and meat market. The dissertation aims to rejuvenate the abattoir as a cognisant, ritualistic social intervention. The design of the abattoir aims to realign the processes of slaughter with notions of ritual sacrifice and ceremony in the context of Mamelodi.

Up until the late Nineteenth-Century, sacrifice and consumption were inseparable (Rifkin, 1992, p. 74). Today, as society continues to preoccupy itself with hygiene and censorship, this connection has been lost.

In response to this cultural ignorance the abattoir is to be reintroduced to the urban network, creating the possibility for the public to experience the full scale of human and non human emotion. Not merely experiencing the beautiful, but embracing the abrasion of the ugly.

Delimitations

The dissertation will focus on new industrial development and will not address adaptive reuse of old industrial buildings.

The abattoir will focus on the slaughter of bovine (cattle) spe-

cies only.

The flexible nature of a new typology will be explored but the dissertation will not address a programmatic change of the building.

Assumptions

The GAPP framework proposal 2011 will be used as the basis for the development framework in and around Eerste Fabrieke Station in Mamelodi.

It is assumed that the existing cattle farm at the Eerste Fabrieke precinct in Mamelodi can be moved across the river west of its current location.

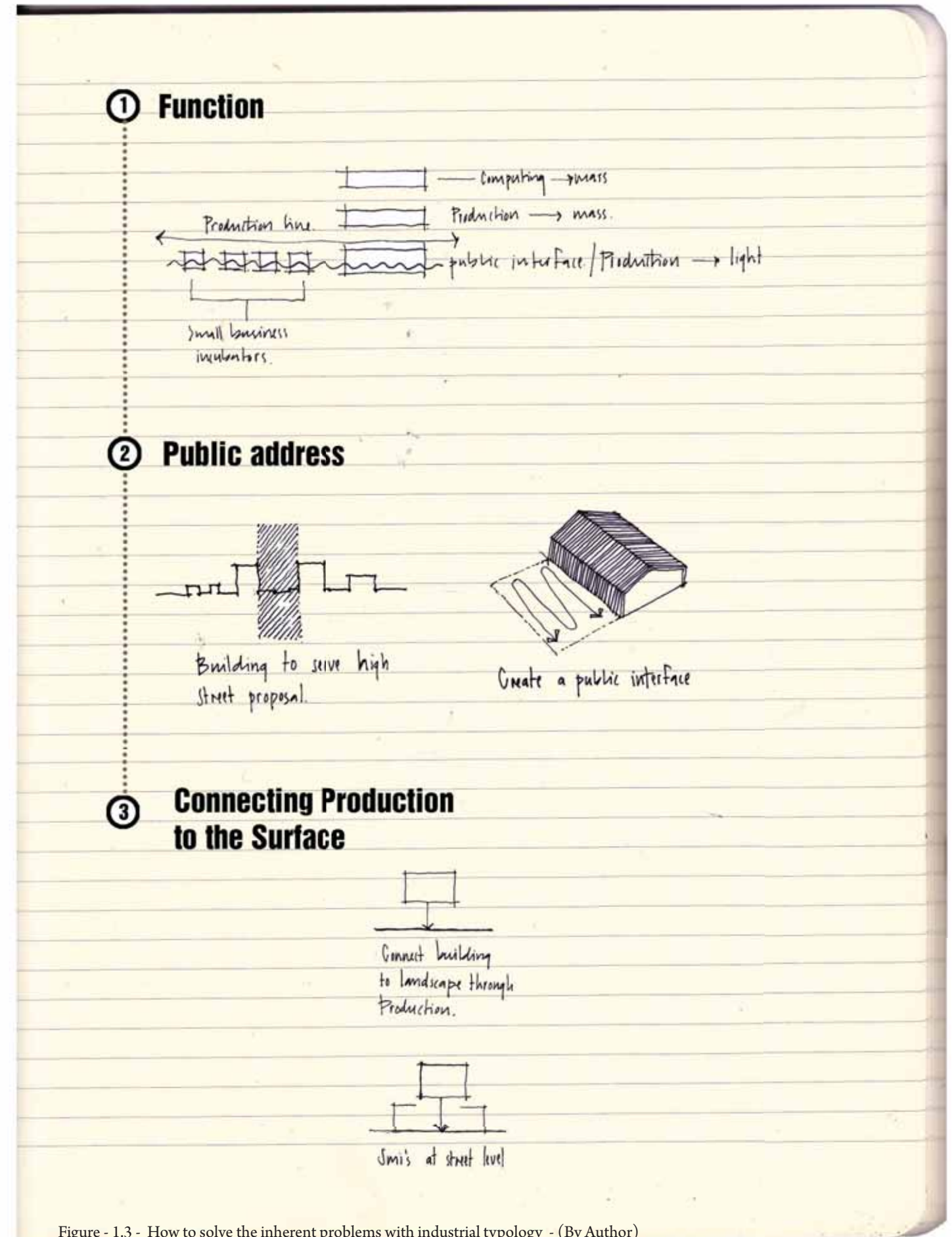

Figure - 1.3 - How to solve the inherent problems with industrial typology - (By Author)

PROGRAMME



Fig - 2.1
Photo of abattoir worker
guiding a carcass along
the slaughter route (By
Author)

RED MEAT PRODUCTION

INTRODUCTION

In the latter half of the 20th Century, meat production worldwide increased almost fivefold and meat consumption soared in industrialising countries such as China. Livestock farming has become the world's largest consumer of agricultural land with the livestock population expanding dramatically to meet the public's demand. Today the ever-increasing human population is sharing the planet at any one time with an estimated 1 billion pigs, 1.8 billion sheep, 15.4 billion chickens and 1.3 billion cattle. (Gold, 2004, p. 1)

With this growing trend it is estimated that by the year 2050 the world's livestock population will be consuming as much as 4 billion people do, which is an increase equivalent to the total world population around 1970. (Tudge, 2003)

"The explosion in meat consumption is paralleled by the global expansion of industrial 'factory farming' of animals. Apart from their environmental impact, such farming systems are based upon the triple insults of selective breeding for high yield, isolation or overcrowding and gross restriction of the animals' natural behaviour."

Joyce D'Silva, CIWF Trust

The Climate Impact of Red Meat Production:

PART 1: HUMAN HEALTH

According to recent studies (WWF, 2009) red meat and other animal related products are the highest in saturated fats, which not only leads to weight related illnesses and cardiovascular disease but also a myriad of cancers in humans. Although red meat intake is much higher in western countries and higher income countries, the recent industrialisation of farmed animals

amongst developing countries like South Africa, India and China has caused the consumption to rise (Popkin, [2008], p. 543).

Red meat contains very important minerals and proteins which humans require in their diet, but moderation is the problem. Consumption of red meat is not the problem at hand but the



over consumption of red meat is what is causing illnesses reaching epidemic proportions (Gold, 2004).

In South Africa the number of cattle slaughtered for public consumption is on the rise since 1997. Supply and demand will allow the industry and its negative effects to grow. African countries have adopted western diets and research shows this trend is growing. It is encouraged by African governments due to large scale international agricultural interests (Weber, 2008, p. 38). A study done by C. S. Williamson, 2005 from the British Institute of Nutrition in London on the global effects of red meat in the human diet, showed that globally, on average, people consume 135.5g of red meat per day which add up to about 950g per week. A healthy weekly diet should contain no more than 400g

2.1

of red meat per week.

Therefore the core problem to be addressed is the over and unnecessary consumption of red meat around the world and the devastating effects it has beyond the human diet.

PART 2: WHO TO FEED?

The livestock farming sector consumes most of the agricultural land worldwide (Gold, 2004, p. 1). In South Africa we require 5 hectares of grain to raise one head of cattle to the age of 18 months when it is ready for slaughter. This same amount of agricultural land could sustain 30 people (Neethling, 2008, p. 55). Rather than adding to our capacity to feed the world's human population, putting animal products at the centre of food

Fig - 2.2 - The rising global meat consumption - (By Author). Information from www.ciwf.org

policy diminishes the possibility of doing so. Apart from animals that predominantly feed on pasture where it is difficult to grow crops and animals that feed on scraps and waste products as part of rotational mixed farming, farm animals use considerably more food calories than they produce in the form of meat (Gold, 2004, p. 4).

Meat is the most resource-costly food as livestock wastes most of the energy and protein value of their feed in digestion and general bodily functions. Rather than using vast areas of land to grow crops for animal feed, more food can be obtained by using land to grow crops for direct human consumption (Gold, 2004, p. 4).

PART 3: WATER SCARCITY

In South Africa a single head of cattle requires 35000 - 40000 l of drinking water during its life, excluding the water consumption for the farming of the grain feed (Neethling, 2008, p. 48). With water becoming a scarce resource and red meat production being a very water intensive process with very low water to calorie output compared to crop farming, the red meat industry has to start restricting its numbers.

Not only is the farming of livestock water intensive but also the abattoir processes is extremely resource intensive. In South Africa, the Rietvlei abattoir in Benoni consumes 1000l of water per head of cattle slaughtered. The Rietvlei abattoir also consumes a daily average of 250 000l per day.

PART4: ENVIRONMENTAL IMPACT

The unsustainably large livestock population is having a devastating environmental impact. Often overlooked as a contributor to global warming, livestock herds account for 10 per cent of all greenhouse gases, including approximately 25 per cent of emissions of methane, considered to be among the most potent (Weber, 2008, p. 88).

A further major problem is created by the sheer volume of waste produced by the farm animal population, estimated at thirteen

billion tonnes every year. Combined with the excessive use of fertiliser to grow their feed, this causes high levels of ammonia and nitrate pollution of land, water and air. Other ecological problems are specific to individual areas. Among the most spectacular have been rainforest destruction in Central and South America in order to rear cattle for the hamburger trade or grow soya for animal feed, and desertification from overgrazing in parts of Africa (Gold, 2004, p. 5).

PART 5: THE WELFARE OF FARMED ANIMALS

The massive increase in meat production would not have been possible without the development of industrialised methods of farming, which have ignored the rights and needs of animals by depriving them of the opportunity for exercise, fresh air and social interaction. Selective breeding for unnaturally rapid growth has created numerous endemic health problems, particularly from leg deformities and heart weakness. Since 1997, the EU has recognised farm animals as **sentient beings**, capable of suffering and feeling pain. It should, therefore, be incumbent upon policy makers to outlaw methods of production which, by their very nature, severely compromise basic welfare standards. Reducing the number of animals bred, reared and slaughtered will facilitate the adoption of more welfare-friendly methods (Neethling, 2008, p. 145).

Market Year	Per Capita Consumption	Unit of Measure	Growth Rate
1997	0	(KG)	NA
1998	0	(KG)	NA
1999	0	(KG)	NA
2000	14	(KG)	NA
2001	14	(KG)	0.00 %
2002	14	(KG)	0.00 %
2003	13	(KG)	-7.14 %
2004	14	(KG)	7.69 %
2005	15	(KG)	7.14 %
2006	16	(KG)	6.67 %
2007	14	(KG)	-12.50 %
2008	14	(KG)	0.00 %
2009	14	(KG)	0.00 %
2010	14	(KG)	0.00 %
2011	14	(KG)	0.00 %

Fig - 2.3 - Meat consumption in South Africa over the past 14 years. From www.statssa.gov.za

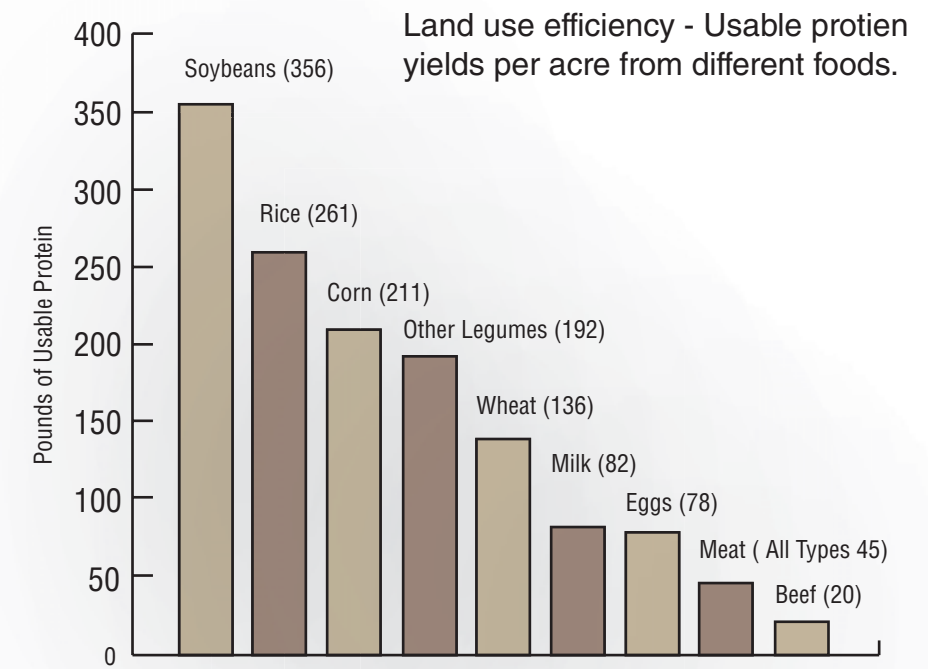

Fig - 2.4 - Comparative agricultural land use efficiencies - (By Author). Information from www.ciwf.org

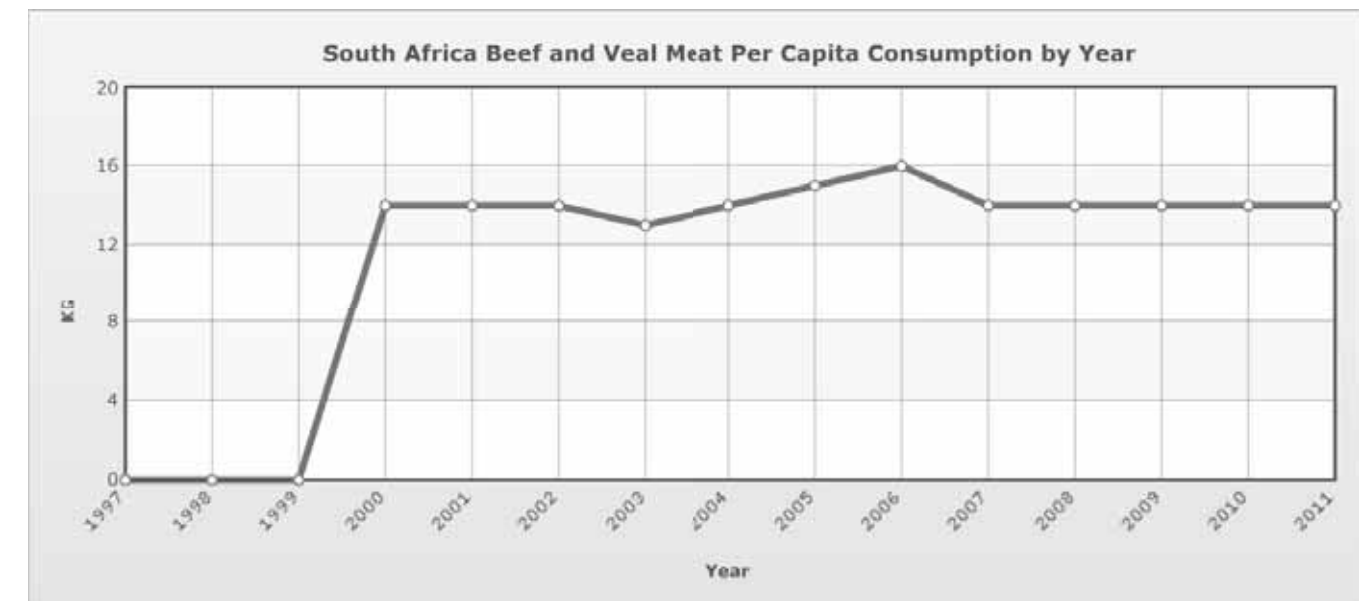

Fig - 2.5 - Meat consumption in South Africa over the past 14 years in graph form.



Fig - 2.6
Brian Hill
Still from 'Slaughter-
house: The Task of
Blood', Century Films,
2005

THE ABATTOIR

INTRODUCTION

"Today the slaughterhouse is cursed and quarantined like a boat carrying cholera. In fact, the victims of this curse are not butchers or animals, but the good people themselves, who, through this, are only able to bear their own ugliness....The curse (which terrifies only those who utter it) leads them to vegetate as far as possible from the slaughterhouses. They exile themselves, by way of antidote, in an amorphous world, where there is no longer anything terrible."

(Bataille, 1997, p. 22).

The slaughter of innocent animals for human consumption rarely enters the minds of people who consume them, and so the place where it happens also becomes a vague destination where the mind does not dare to dwell. The activities housed inside abattoirs include the killing and evisceration of animals, the arduous process of sanitizing and cleaning of blood, entrails and other organic matter makes this industrial building typology a

taboo subject. The abattoir is therefore situated out of sight and out of mind in smaller rural communities so that the abrasive reality of the abattoir does not upset our "affected ignorance" (Williams, 2008, p. 10) of our everyday lives.

The abattoir was not always such a taboo subject and in the past they were situated much closer to home, but the development of new technology, industrialisation and the modern school of thought drove a bigger wedge between mankind and nature and the abattoir found itself ousted from urban settings.

THE HISTORY OF THE ABATTOIR

The abattoir emerged in the early nineteenth century as a unique institution with the shift from an agrarian to industrial system which was accompanied by increased urbanisation, technological advances and concern about civic hygiene. Prior to this change of system, animals were slaughtered for consumption in diverse locations such as backyards. The banishment of the



Abattoir



Ritual Slaughter

Fig - 2.7 - A Relationship can be established between Mechanical and Ritual Slaughter.

slaughterhouse started in the early eighteenth century when private abattoirs were starting to be scrutinised and the public abattoir was the more favourable solution. This was due to the state (United States of America) believing that public abattoirs were easier to monitor and generally more hygienic and that the state needed to regulate "morally dangerous" work in the favour of the general public (Fitzgerald, 2010, pp. 58-59).

The first public slaughterhouse was erected in the early 19th century in France and the word abattoir was established to refer to a place where animals were to be slaughtered for human consumption (Rifkin, 1992, p. 12). Other Western European countries took note of this "public abattoir" development and started developing their own public abattoirs outside the city walls, but the greatest contradiction was that these "public abattoirs" were hidden from public view.

"The abattoir, invisible but not secret, may have been built in response to concerns about civility, or feelings of deep repulsion, but in turn it created the conditions under which true disgust can be felt."

(Rifkin, Beyond Beef: The Rise and Fall of Cattle Culture, 1992)

In the United States of America the development took a different route and by the mid nineteenth century the animal slaugh-

ter and processing industry was concentrated in a few cities namely Chicago, Cincinnati, St Louis and Kansas City. Chicago became the pioneer of the industry with the development of the Union Stock Yard which opened in 1865. The Union Stock Yard was a colossal slaughtering complex like nothing before it and was home to the industrialisation of the slaughtering industry (Smith, 2002, p. 52). According to Amy J. Fitzgerald, anthropologist from Canada, the industrialisation of the slaughtering industry was the first industrialised process in the USA and developed numerous new technologies. The most significant development of the abattoir was the conveyor belt, Henry Ford based his assembly production line for the Model T Ford on what he learnt from the abattoir.

The Union Stock Yard became home to many workers and soon slum like conditions emerged with the crowded conditions and poverty associated with the slaughtering process. The mechanisation of the slaughtering process resulted in a loss of jobs at the abattoir which further worsened the living conditions. The Union Stock Yard era extended into the early twentieth century when it was finally replaced by the European "Public Abattoir" model almost one hundred years after its implementation in Europe (Fitzgerald, 2010, p. 60). The Union Stock Yard era was characterised by the central urban slaughter of animals, driven



Fig - 2.8 - Illustration by David Lupton. The illustration expresses the hyper separated state between man and nature.

by the idea that it was easier to deliver carcasses to markets than to transport live animals.

In the 1960's the new era of industrial slaughter took over the United States industry and slaughtering became part of the larger industrial sector (Fitzgerald, 2010, p. 61). The abattoirs were therefore located on the periphery with the rest of the industrial praxis and further mechanisation of slaughtering resulted in a decline of skilled labour being required. The architecture of the abattoir was in most cases ordinary industrial buildings and in Noelle Viallis's words (1994, p47) the abattoir is a place of no place and the geography of the architecture serves to avoid a "collective cultural guilt". This separation of the public from the slaughtering process of the animals they consume, the act of killing and the natural environment in which the animals are raised, developed into a hyper separated state with the mechanisation and industrialisation of animal slaughter.

In South Africa, livestock is being slaughtered at 461 abattoirs producing roughly 1.75 million cattle, 4.5 million lamb and 1.87 million pig carcasses annually (Neethling, 2008, p. 1). The slaughter industry in South Africa has followed the same development path as that of the USA, and the mass industrialisation of slaughtering has caused local abattoirs to be situated in peripheral locations (Neethling, 2008). There is however a dichotomy in the slaughter of livestock in South Africa, on the one hand there is the mass industry of mechanised slaughter for consumption by the general public and on the other hand there is the ritual or tribal backyard slaughter which takes place predominantly in the black townships which contribute to roughly 100 000 animal carcasses annually (McCrinkle, 2004, p. 5).

Ritual slaughter in South Africa is legal, but it is illegal to sell the meat commercially for public consumption according to the Animal Protection act of 1947 no 36. Ritual slaughter usually takes place at weddings, funerals and on reaching puberty. This type of slaughter has no hygienic consideration and can lead to the poisoning of public drinking water, food poisoning and the pollution of other amenities through the illegal dumping of carcasses (McCrinkle, 2004, p. 5). Part of the traditional ritual slaughter process is to consume all edible parts of the animal and use as much of the waste for functional purposes. Skins are used as carpets or manipulated into clothing, blood is used as side dish for other meals etc.

This new era of slaughtering which was reached in the 1960's is still the current status quos in South Africa today. The abattoirs are all situated large distances from urban areas amongst more rural communities and is no longer a process which is witnessed by the public at any level. It is truly out of sight and out of mind. With the current shift in paradigm to a more sustainable approach to production, the abattoir typology is being revisited because of the severe pollution which takes place in and around the abattoir and the ethical shift for the welfare and ethical treatment of animals.

CONCLUSIONS:

Abattoir and ritual slaughter should be closer connected. Abattoir slaughter can provide hygienic and sustainable facilities for ritual slaughter and in turn ritual slaughter, which places a lot of respect on the life of an animal, can return some sense of civility to the mechanised slaughtering process.

Ritual slaughter can contribute to a new interface between the abattoir and the public - ritual and sacrifice can be introduced into the abattoir by the complete recycling of the animal as done in ritual slaughter. This can help establish a public platform for engagement through making these recycled and processed products directly available to the public from the abattoir.

The abattoir needs to be moved back into more urban areas where control over unsustainable and cruel practices can be publicly monitored.



Fig - 2.10- Formalised ritual slaughter - no hygienic considerations.



Fig - 2.11- Makeshift hoist for ritual slaughter.



Fig - 2.12- Backyard ritual slaughter.



Fig - 2.13- Cattle roam the streets in townships eating whatever they can find.



Fig - 2.14- Makeshift transport can cause death or serious injury to animals.

The Abattoir - 400 - 1000L of water per head of cattle slaughtered. **250 000L** of water per day. **35 600L** of water to raise on head of cattle. **5 Hectares** of grain per head of cattle raised. **10%** Of total greenhouse gasses from red meat livestock. **25%** Of methane deposits from red meat livestock.

13 Billion tons of global waste annually. Ammonia and **Nitrate** pollution of **air, water** and **ground**. **2-5 Times** more water consumption than crops. Red meat production consumes **23%** of the worlds water. Farming of animals contribute **55%** of worlds erosion pollution, **37%** of pesticide pollution and **50%** of antibiotics pollution in **water** and **ground**. The meat industry also accounts for **25 - 35%** of global **fossil fuel** consumption. It is the **most expensive** food type to produce. Produces the **lowest amount of protein per hectare** farmed - **20 pounds** per hectare for cattle vs **356 pound** per hectare for **soy beans**. Continuing the current trend by **2050** livestock will be **consuming** the same amount as **4 billion humans**. Is currently the cause of **deforestation in South America** for hamburger farming and **desertification in Africa** due to **overgrazing**.

Red meat is one of the leading causes of **cancer** and **cardiovascular disease** in humans. Meat, meat products and dairy products contain more **saturated fats** than any other food type which causes **obesity** and health **complications**. African countries have **adopted western diets** and research shows this trend is growing. It is encouraged by African governments due to large scale **international agricultural interests**. This in return is causing the red meat **industry to grow** in Africa and the rest of the world. In India and China red meat consumption has **doubled** from **2005** till **2010**.

2.3



Fig - 2.15
 Photo of cattle hanging from the roof during the bleeding process (By Author)

SHIFTING SENSIBILITIES AND THE SOCIAL IMPACT OF THE ABATTOIR

Human's relationships to animals have changed drastically over time up until the hyper separated state in which mankind currently finds itself (Fitzgerald, 2010, p. 59). This change according to the political ecologist Richard Bulliet in his book *Hunters, Herders and Hamburgers* (2005) can be classified into two periods namely the domesticity period and the post domesticity period. The domestic era was defined by daily human contact with animals due to the social and economic structures of the time, whereas the post domestic era is characterised by the physical and psychological separation of man and the animals that produce the everyday products which he so readily consumes. Bulliet argues that the post domestic era took shape in the 1970's when animals merely became a resource, a standing reserve for the exploitation by mankind.

The post domestic era has come, as with the contemporary abattoir, under extreme scrutiny with the new shift to a sustainable paradigm. People are becoming aware of the cruelties to animals even if they are out of site and mind on the periphery of urban centres and people are showing a concerned interest in where their food comes from. Not only is the ethics of the abattoir coming into public debate but also the severe pollution which happens in and around abattoirs. Further tension is building up as we move deeper into the post domestic era due to the demand for food which is increasing and the quality of the creatures' lives which is deteriorating (Rifkin, 1992, p. 15).

"The greater the degree of mechanisation, the further does contact with death become banished from life"

(Siegfried Gideon 1969, p.242)

The concern with the post domestic era and the holocaust like slaughtering of animals has merely resided as a concern; the growing meat industry confirms that with all the concerns being

raised, not much is being done. The geography of the contemporary abattoir from central urban location to peripheral rural location is evidence of an attempted cultural amnesia regarding the slaughter of animals. Fitzgerald argues that putting the gruesome nature of what happens in abattoirs out of mind gives rise to a new kind of cruelty on a "more deeply hidden scale" (2010, p. 59); fuelled by an "affected ignorance" (Williams, 2008, p. 10).

In addressing the abattoir's inherent problems the physical geographical separation and the psychological dislocation need to be addressed in order to create public discourse. The inherent problems with abattoirs can be solved with technology specifically design for these places. Mira Engler states that we "*re-examine the nature of the apparent oppositions between clean and dirty, between central and marginal landscapes (positively and negatively valued landscapes), to nurture dialectical relationships between the margin and the centre, and to focus on the specificity and potential of waste, dirt, and marginalia... [and] normalise and integrate places of waste into communal and public space in the everyday landscape*" (2004, pp. p. xvi-xvii) which aligns itself with the dichotomy of South African slaughter; the hygienic mechanised process and the dirty backyard ritual slaughter. These elements can be displayed in the reinterpretation of the abattoir and the role it plays in new urban development.

The abattoir needs to return to the urban setting where it first found its existence in the pre domestic era. The current trend of the post domestic era is not sustainable due to the increasing amount of livestock required to maintain the increasing need for food and the unsustainable praxis surrounding the process of slaughter.

CONCLUSIONS:

A move beyond the current praxis is required, which has similar man/nature relationships as the pre domestic zeitgeist to sustain abattoir practices in a regenerative relationship between humans, animals and the environment.

Further justification for the relocation of abattoirs to more urban settings for it needs to create public discourse because the acknowledged existence of ani-

mals and their violent death is required for a regenerative relationship to be fostered.

The problems that abattoirs present namely: smells, sounds and hygiene, in urban settings can be addressed with new technologies developed specifically for abattoirs.

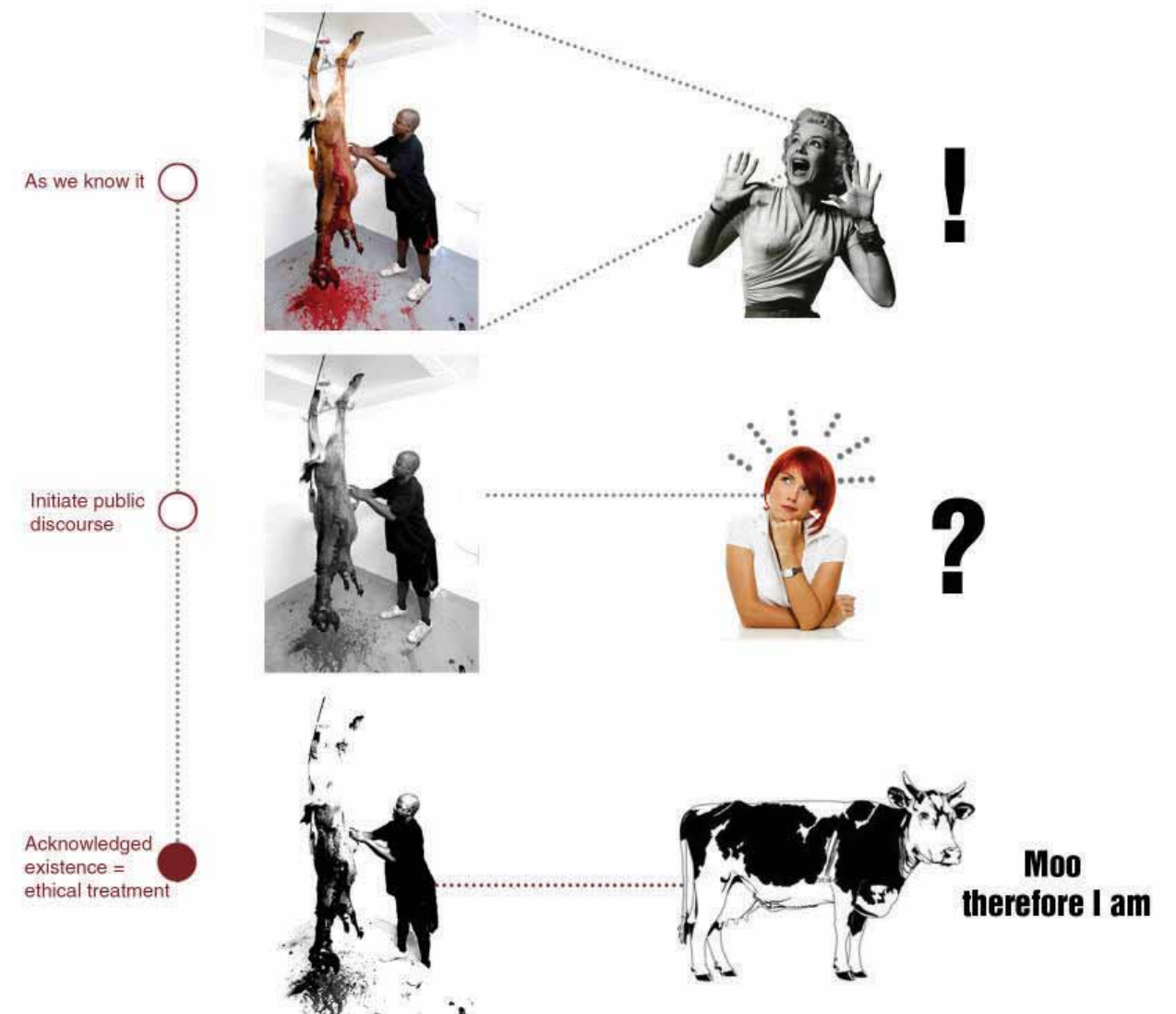

Fig - 2.16 - Digital image (Compiled By Author) depicting a required public discourse.

Antennae

Issue 5 Spring 2008

ISSN 1756-9575



The Death of the Animal

Jonathan Burt The Aesthetics of Livingness **John Isaacs** Wounded Animals and Icon-Making **Noelle Allen** Contemporary Memento Mori **Claire Brunner** The Flesh House **Brian Hill** Slaughter House: The Task of Blood **Marco Evaristi** Helena **H-Animals Readers** The Goldfish Thread **Giovanni Aloï** The Death of the Animal **Sue Coe** In Conversation

Fig - 2.17 - Cover of the Antennae online magazine issue dealing with the death of animals in art.



Fig - 2.18 - Photograph (By Author) of an abattoir worker cleaning the heads of the cattle.

THE CALL FOR THE ANIMAL VOICE TO BE HEARD

"Every animal finds a voice in its violent death; it expresses itself as a removed self."

(Hegel in Agamben 1941, p.45)

The Pedi tribe in South Africa treats animals with such respect they refer to them as *'kgomo ke modimo mo nko e metsa'* (a beast is a god with a wet nose) (McCrindle, 2004, p. 9). Ritual slaughter is sometimes extremely cruel but there is immense respect for the animals. The Pedi tribe stabs the animal (cattle, goat etc) behind its left shoulder with a traditional weapon called an "as-segai" and then waits for the animal to die. The bellowing of the animal is perceived as communication with their forefathers and deities. Therefore, as Hegel comments, the animal has found a voice in its violent death, which is more self expression and respect that it will ever be given in an abattoir. The animal is further respected by the complete use of all its parts. The hide, viscera, bones, blood and all the meat are consumed or processed for everyday use. Almost no part of the animal gets wasted.

The contemporary abattoir does not facilitate an ethical relation to the animals, one that respects them for what they are, it merely treats them as a standing reserve to be harvested. This can be seen when observing an abattoir where 400 cattle are slaughtered per hour without a single flinch, which reiterates Siegfried Gideon's statement (p.36) about the mechanisation of slaughter. The public is physically shielded and geographically separated from abattoirs where the standing reserve is harvested and results in a "ritual"-less, un-ceremonial death without a notion of sacrifice (Smith, 2002, p. 50). The first of the 8 Hannover principles generated by William McDonough states: *"Insist on rights of humanity and nature to co-exist in a healthy, supportive, diverse and sustainable condition"*, therefore to foster a truly regenerative sustainable relationship the animal voice must be recognised and the notion of a sacrifice must be reattached to

every animal that dies for human consumption.

The space of the abattoir is indicative of the need to reconceptualise our social relations with the non-human world to regain an ethical sensibility and a sense of responsibility for what happens around us that has been dissipated in the rush for economic gain and technical progress.

A transformation of modern social space is required which does not keep potentially cultural contaminating contacts with boisterous animals at arm's length (Smith, 2002, p. 55) to re-establish the relationship between sacrifice and consumption, which was inseparable up until the 20th century (Rifkin, 1992, p. 74).

"To grant the reality of the animal voice in no way denies the myriad of differences between animal and human lives but instead calls for an attentive listening to the manner in which these differences are denied expression in the factory farm and the abattoir"

(Smith, 2002, p. 57)

The call for the animal voice to be heard is an ethical closeness which sustains the differences between man and animal, and this gives the animal self expression. The self expression of the animal is what the RSPCA, SPCA and Freedom Food outlines in their Five Freedoms for farm animals (refer to heading 2.8). To establish these new relationships between man, animal and environment a new abattoir typology is essential. The space of the abattoir is indicative of the need to reconceptualise our social relations with the non-human world, regain an ethical sensibility and a sense of responsibility for what happens around us that has been disintegrated in the quest for economic gain and technological advancement (Fitzgerald, 2010, p. 65).

2.4

"The success of any civilisation can be judged on the way they treat their animals"

Ghandi

CONCLUSIONS:

The notion of sacrifice needs to be re established in the abattoir.

A synthesis of ritual African slaughter and the contemporary abattoir can establish the notion of sacrifice with mechanised slaughter in a hygienic and safe environment.

A new typology for the contemporary abattoir is critical to achieve ethical and sustainable relationships between man, animal and nature.

**Moo
therefore I am**

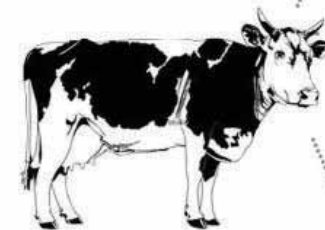

Fig - 2.19 - Conceptual figure showing the re establishment of the non-human in human minds.

DEFINING THE NEW ABATTOIR

THE FIVE FREEDOMS

The Royal Society for the Prevention of Cruelty to Animals (RSPCA) is an international non profit organisation which enforces the welfare of all animals. Together with the Farm Animal Welfare Council (FAWC) they created Freedom Food inc. and the Five Freedoms for farm animals. Freedom Food is a wholly owned subsidiary of the RSPCA, formed to implement the Five Freedom standards. Upon satisfactory inspection, farmers, hauliers, slaughterers, processors and retailers may subscribe to the scheme and use the Freedom Food trademark. All participants are regularly assessed by Freedom Food Ltd. A charge is levied to cover inspection, administration and marketing costs. Participants are also randomly monitored by members of the RSPCA Farm Animals Department, free of charge. (www.RSPCA.com, 2011) The Five Freedoms as developed by the RSPCA, FAWC and Freedom Foods:

Freedom from hunger and thirst by ready access to fresh water and a diet to maintain full health and vigour.

Freedom from discomfort by providing an appropriate environment including shelter and a comfortable resting area.

Freedom from pain, injury or disease by prevention or rapid diagnosis and treatment.

Freedom to express normal behaviour by providing sufficient space, proper facilities and company of the animal's own kind.

Freedom from fear and distress by ensuring conditions and care which avoid mental suffering.

Applying the Five Freedoms to the design of a new abattoir is the first step in achieving a truly regenerative architecture which can satisfy the Hannover principles. The Five Freedoms also outline the self expression of the animal not in death but through its life by providing proper facilities and care.

The new abattoir not only has to fulfil ethical treatment of animals but also due to its new geographical urban location has to satisfy rigorous environmental considerations for it not to contaminate its surroundings. The current abattoir typology suffers from severe air pollution regarding smells, noise pollution from the animals making noise and also physical pollution of the earth through improper disposal of animal waste (Goddard, 2007, p. 2). By addressing these pollution factors the abattoir can be reintroduced into an urban context without jeopardising the environment.

The new Wotton abattoir design for Cranswick Foods in the UK spent £3 million on creating a truly environmentally friendly building. They focused on several aspects namely energy recovery, reduced water use, energy, emissions control and waste recycling to achieve a high performance abattoir (Goddard, 2007, p. 4). (These aspects will be covered in more detail in chapter 5).

Fig - 2.20 - Photograph by author of cattle waiting in pens prior to slaughter (By Author).

2.5

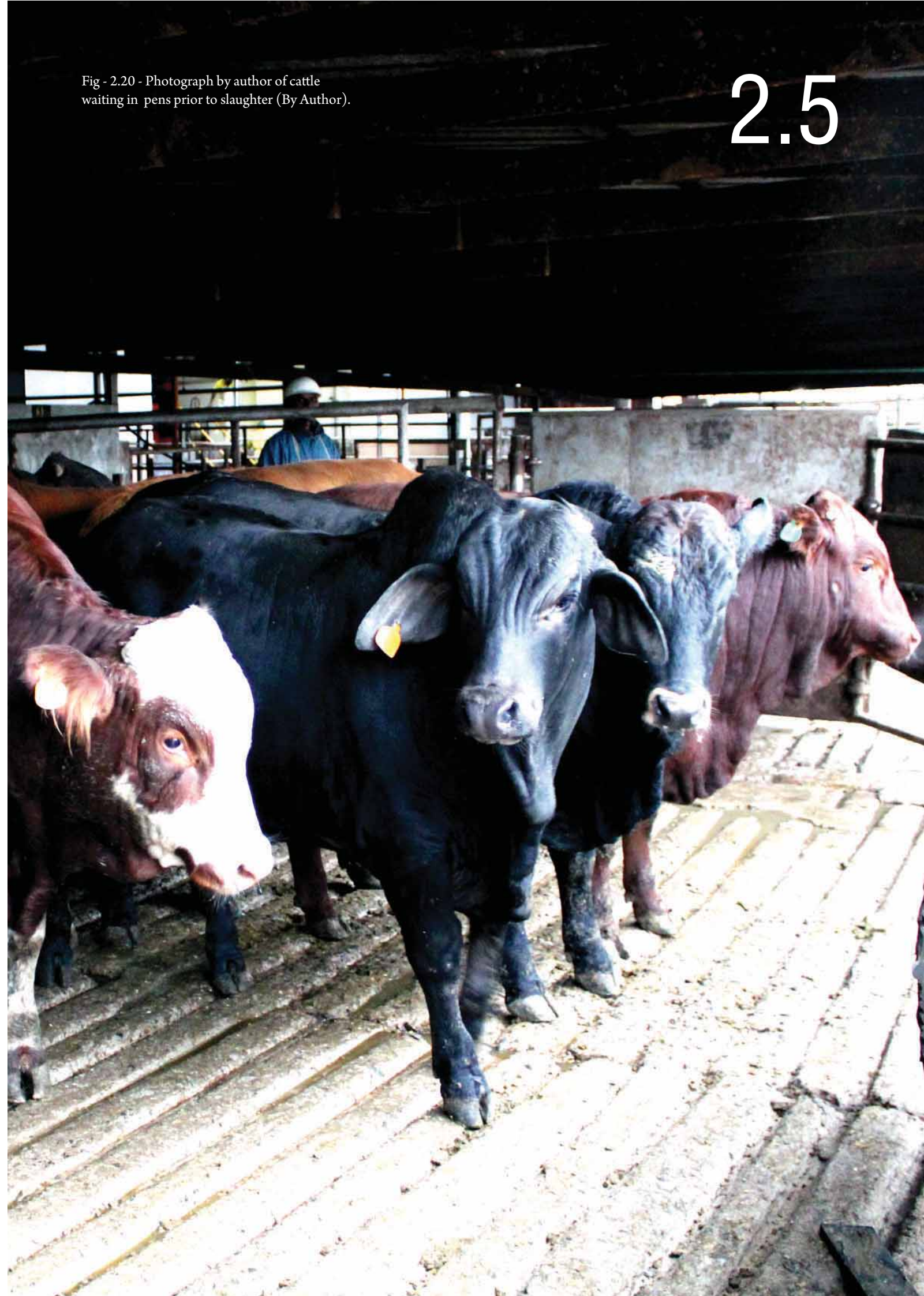

3.0

THEORY



Fig - 3.1
This photograph is from
Phil D's photographic col-
lection of derelict indus-
trial buildings. All photos
Available on www.Flickr.com

A REQUIRED CHANGE FOR A STATIC TYPOLOGY

BACKGROUND OF TYPOLOGY

"Most design decisions are still made from a snap shot in time"

(Jenkin & Worthington, 1996, p. 92).

The typology of industrial architecture dating back to 1750 with European Mill architecture has from its early beginnings been a typology of the pragmatic (Jones E., 1985, p. 12). It merely intended to solve the problem at hand with minimal expense and thought to the humanisation of space. Therefore architects were never commissioned to design these places of production; it was left to engineers (Sen, 2004, p. 1).

Industrial architecture was not seen as a typology that contributed much to architectural history, but in 1909 Peter Behrens pulled the typology from obscurity and started to design monumental industrial buildings such as the AEG turbine factory in Moabit, Berlin. Other architects such as Walter Gropius also drew inspiration from industrial typology as it was the most honest of architectural styles and one of the few that inspired the modern movement. Free of ornament and solely based on programme and technology, it led the way in innovative building design and technological development (Jenkin & Worthington, 1996, p. 87). This monumental approach to the industrial typology resulted in singular static artefacts which were/are mono-functional and could not adapt to the changing nature of production.

In 1963, Walter Gropius saw the failings of the typology as a purely pragmatic solution and started working on an industrial architecture that humanized the work environment to free workers from the monotony of the manufacturing processes (Sen, 2004, p. 4). He added new programmes and spaces to industrial buildings such as aviaries, conservatories, information centres and leisure-time facilities. This initiated the start of the

High Tech movement which readdressed the typology. This time, a modular approach was taken to the design of pragmatic space. The space had to be adaptable; instead of building single artifacts, rather whole collections of artefacts were constructed to forever change with its environment or occupant. The High Tech movement made no allowance for context in design. Architecture was not seen as a high brow art or philosophy but as a technique.

This separation from landscape, context and the urban framework has left the industrial typology deserted and regarded as wastelands or "terrain vague" as coined by landscape architect Ignasi Sola Morales. It failed once again due to this disjunction, even though the typology was made more flexible, it was removed from its context and therefore was never allowed to change.

Today there is another resurgence of interest in industrial typology, developed around the paradigm of sustainable development. Adaptive reuse forms the core of this approach and focuses on the reuse of existing building stock in urban areas in order not to waste the embodied energy within these structures. Many post - industrial cities have used their existing industrial building stock in recent years by conversion into cultural centres such as in Manchester, Glasgow, Barcelona and Baltimore, all based on the successful adaptive reuse principle. There seems to be hardly any other way to approaching development in the near future as greenfield sites become scarcer and brownfield sites more abundant.

Irene Curulli (2006, p. 33) sees a definite resemblance between agriculture and derelict industrial sites when she says: "Industrial wastelands are temporary inactive lands, left bare for a period of time in order to recover natural fertility" which also echoes what Ajanta Sen (2004, p. 8) says:

Figure - 3.2 (Right)- Photograph by Ester Havlova from her "Fragments" collection

3.1

"perhaps it is its fate that to stay alive, industrial architecture must metamorphose or recede every once in a while to make space for the new."

CONCLUSIONS:

The industrial typology needs to be reconnected to the productive urban network via a new public interface.

To avoid becoming defunct objects, industrial architecture needs to become flexible to context and not just programme.

The embodied energy of industrial architecture needs to be minimized through material selection and a new approach beyond the architecture of economy.

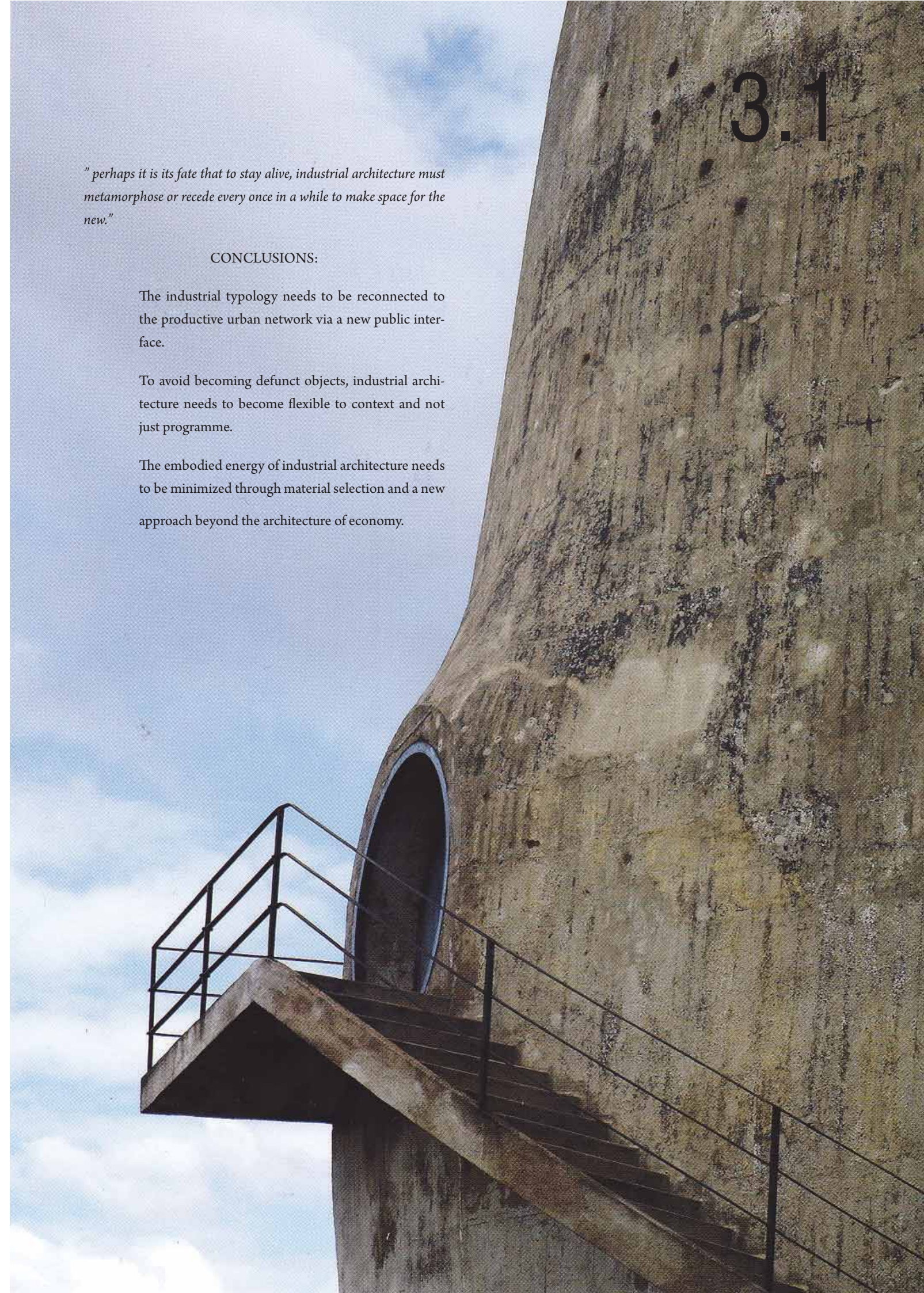

THE THIRD INDUSTRIAL REVOLUTION

The world is approaching the end of the oil era with peak oil rates within sight in the coming years (Rifkin, 2009, p. 4). Concurrently the levels of CO₂ emissions being deposited into our atmosphere due to the combustion of fossil fuels are also increasing at an alarming rate. At present, the global Green House Gas (GHG) concentration in the atmosphere is 430ppmv CO₂e, and is rising at more than 2ppmv per year. (Stern, 2010, p. 9) This is causing global temperatures to rise and will result in an ominous future for mankind and the natural eco systems if something is not done immediately.

"We require a new economic narrative that will push the discussion and the agenda around climate change and peak oil from fear to hope and from economic constraints to economic possibilities. That narrative is just now emerging as industries across Europe begin to lay the groundwork for a post-carbon Third Industrial Revolution"

(Rifkin, 2009, p. 1).

The Third Industrial Revolution (TIR) is upon us and is characterised by a change to a sustainable paradigm and requires a new architectural typology for a new industry to refrain from perpetuating the mistakes of the past and preserving the future. The Information Technology (IT) industry has revolutionised the global social context with the inventions of social utilities and the global growth of the Internet, industry requires the same revolutionary impetus to achieve a sustainable future (Rifkin, 2009, p. 2). Globally, the third industrial revolution is defined by emerging industries such as Bio Fabrication, Social Utilities, Nano Technology and science based industries. These industries define the new revolution for first world countries which currently have the infrastructure, funding and expertise to support it. In the global context South Africa is classed as a developing country and industry development is required to alleviate poverty and achieve growth. The new global industries namely Bio Fabrication, Nano Technology etc. will therefore not be seen in the near future of South African industry, but this does not mean South Africa cannot be part of the TIR.

Developing countries such as South Africa have to form the benchmark of sustainable industrial development for the rest of the world (Stern, 2010, p. 15). Industry will continue to expand in developing countries and their part in the TIR will be to develop within a sustainable framework of emissions targets and regenerative urban principles. If development is to happen within a sustainable framework, the foundations for emerging industries of the TIR will be laid and their realisation will become more feasible in the near future (Rifkin, 2009, p. 12).

"The environment is not a competing interest: it is the playing field on which all other interests intersect."

(Cortese, 2001, p. 4)

The architecture of the TIR will play a pivotal role in its success. Currently, the construction industry contributes 50% of all carbon emissions and 70% if transport associated with construction is included (Jones P., 2009, p. 1). Sustainability in architecture is the only way to make the TIR a reality and should be incorporated into the architecture of industry as the industrial typology of yesteryear has left us with industrial wastelands. Since the industrial revolution humanity has based the built environment on systems, patterns and technologies in opposition to the natural world. Architecture and explicitly industrial architecture is the worst contributor to this condition. The approach to the design of areas of production depicts a severance between nature and the built environment which so rapidly consumes it (Littman, 2009, p. 15).

"The virtue is in producing, without possessing nor dominating"

Tao Te King



Figure - 3.3 - The Third Industrial Revolution

Architecture engages its environment where it is placed and the vast divide between the natural landscape and industrial typology needs to be addressed. A paradigm shift is required, a shift beyond sustainability, which does not just control the environmental impact but also has a positive impact on its immediate surroundings. Buildings should act as positive power plants that can regenerate and enrich landscapes. Industrial architecture has to move rapidly because our and its survival lies in movement as Ingnasi Solas Morales says. The typology needs to shift from:

Industrial architecture to Sustainable architecture / Regenerative Architecture

And from

Architecture of Economy to architecture of Social Responsibility.

CONCLUSIONS

South Africa is not yet ready for the new global industries and focus should be put on readdressing the existing industry to provide a benchmark for sustainable industrial development.

Readdressing the old industry will provide the infrastructure for the TIR in the future.

The red meat industry is one of the oldest and most environmentally taxing industries in the world and can be readdressed to aid the development of the TIR.

A shift beyond sustainability is required as sustainability only sustains an already damaged environment. A regenerative relationship between the built and natural environment is required.

“The great pivotal economic changes in world history have occurred when new energy regimes converge with new communication regimes. When that convergence happens, society is restructured in wholly new ways.”

(Rifkin, 2009, p2-3)

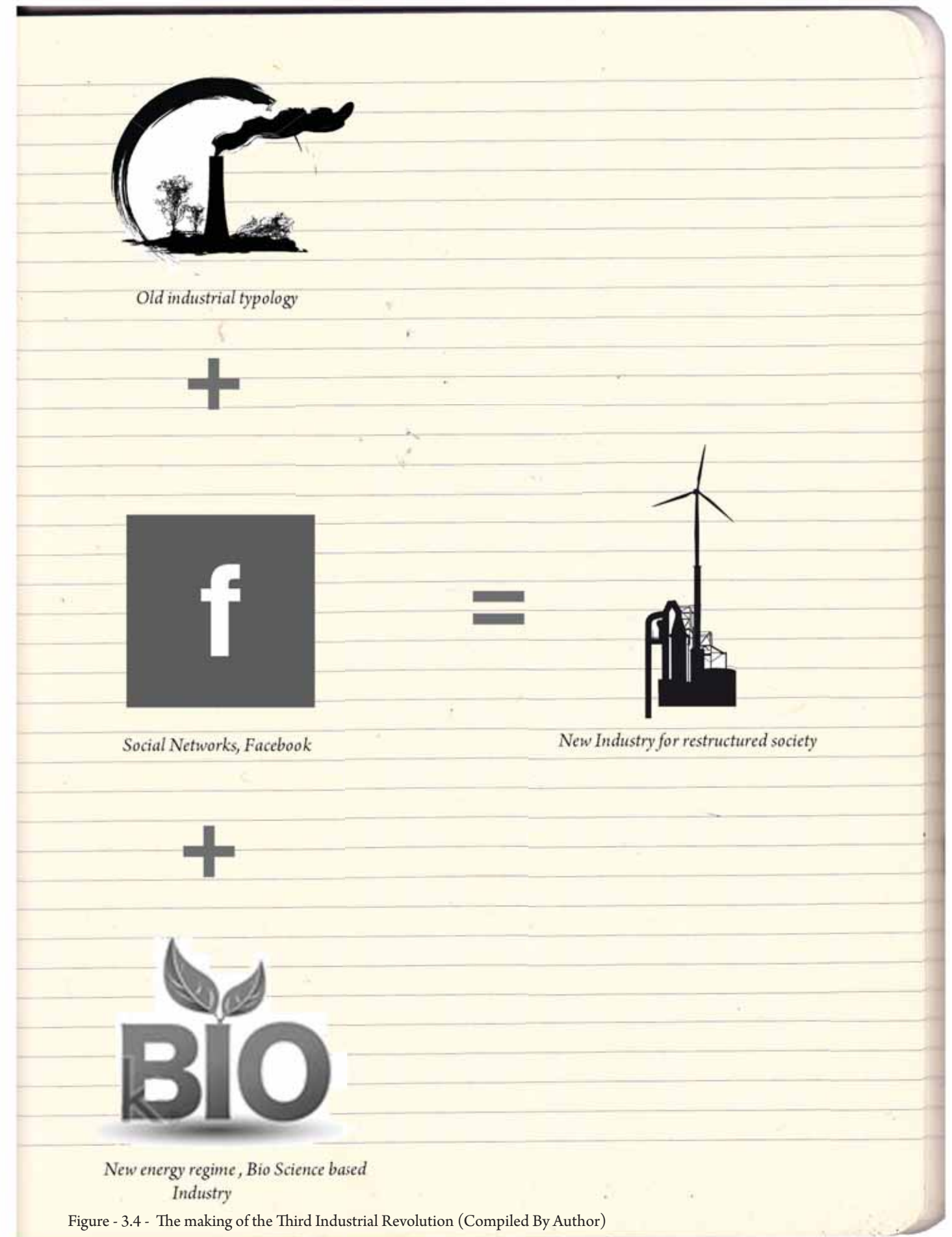

Figure - 3.4 - The making of the Third Industrial Revolution (Compiled By Author)

HERITAGE: RECYCLING HISTORY & MEMORY

“Places of cultural significance enrich people’s lives, often providing a deep and inspirational sense of connection to community and landscape, to the past and to lived experiences. They are historical records, that are important as tangible expressions of identity and experience. Places of cultural significance reflect the diversity of our communities, telling us about who we are and the past that has formed us and the landscape. They are irreplaceable and precious. These places of cultural significance must be conserved for present and future generations. The Burra Charter advocates a cautious approach to change: do as much as necessary to care for the place and to make it useable, but otherwise change it as little as possible so that its cultural significance is retained.”

Burra Charter (1999, p.1)

When dealing with deserted industrial sites, the general trend has been the “face-lift” (Curulli, 2006, p.30) approach where the heritage of the site is wiped clean, the characteristics of the site itself is denied and the differences are wiped out. The Burra charter was created in 1979 to aid the preservation and development of such sites and to prevent important heritage to go missing and become forgotten.

“As human activities have spread over territories of unusual dimension, huge industrial zones, former military installations, and outdated infrastructure—the sites of nineteenth- and twentieth-century modernity are suddenly empty.”

Bernardo Secchi (2007, p.6)

Abandoned industrial sites in the urban landscape are loaded with memory as they bore witness to human and technological progression. They are rich empty spaces which demand to be read, translated and responded to as they embody the inescapable passage of time. Within these “rich lacunae” (Curulli, 2006, p.32) lie the possibility for the stimulation of perception to-

wards stigmatised post industrial spaces and to inspire memory.

“Interpreting industrial wastelands is a work against amnesia”

Irene Curulli (2006, p.32)

The regeneration of derelict industrial spaces is rapidly gaining importance as brownfield sites are becoming more abundant. Regenerating these spaces requires the ground to be seen as a written page as Irene Curulli suggests. As these spaces carry inscriptions of the past and support the city’s identity.

Irene Curulli, lecturer at Eindhoven Technical University and Owner of architecture and landscape firm, Terrafirma, specifically deals with the regeneration of old industrial sites and has written numerous papers on the subject. In her paper *“Reuse or Abuse? Ethics in Requalification Design (2007)”*, published in *Places: The Future Metropolitan Landscape Volume 19*, she outlines a series of design approaches to address abandoned industrial sites. She refers to the design process as *Requalification Design* which consist of four steps:

1. Product or Potential - ensure continuation and evolution of site by reading its potential and not focussing on a product.
2. Effective Divestment - selective treatment of the past to allow introduction of the new. This aligns with the Burra charter’s creed to do as much as is necessary and as little as possible .
3. Appropriateness of new programmes - the selected programme must not devalue the potential of the heritage on site.
4. Pride of rhetoric - acknowledge the existing heritage to understand what new architectural expression can contribute.

These four principles ensure not only the *Requalification* of the site, but the regeneration of a deserted landscape. The potential

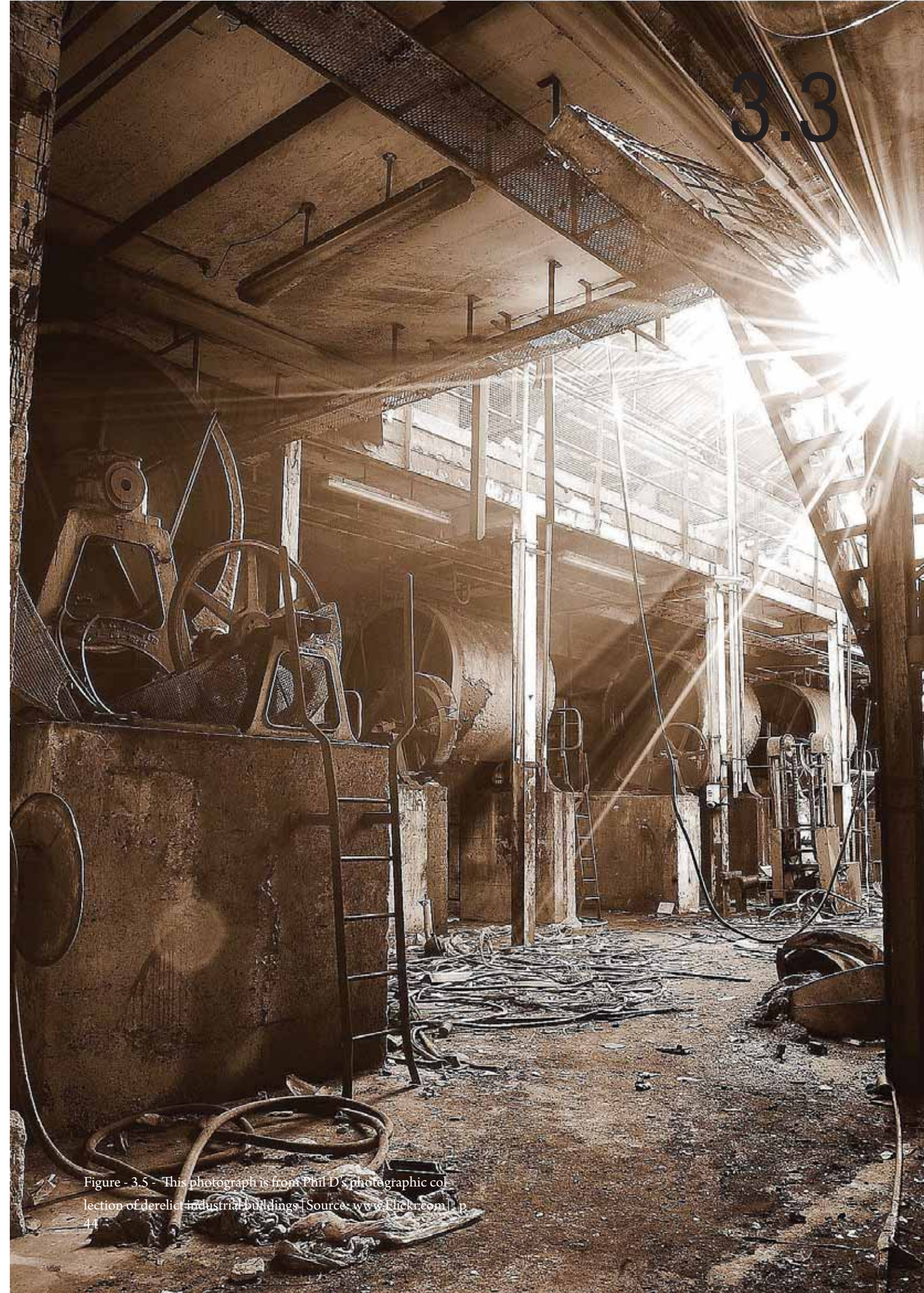

Figure - 3.5 - This photograph is from Phil D's photographic collection of derelict industrial buildings [Source: www.flickr.com] p. 44

of the site must be uncovered so that these sites do not become the garbage of tomorrow.

“True recycling changes perception and restructures judgement”

Irene Curulli (2007, p.17)

Donlyn Lyndon writes that if these spaces and memories contained within them can be traced and projected with clarity, they can become a source of both change and continuity.

The above theoretical approaches by Irene Curulli and Donlyn Lyndon are to establish the angle of approach for the design of the abattoir on the Eerste Fabrieke precinct site.

The site holds many remnants of its previous occupation and these are to give form and structure to the proposed new development and eventually the final product within this development.

By adhering to the historical development of the site (refer to chapter 5) the development will attempt to reinforce and revive the historical importance of the site. This will create a continuity and change, as both Curulli and Lyndon argue, that are necessary by establishing a new trend of production built upon the old.

The existing built fabric is to be revived where possible by rebuilding and repairing and re-establishing a sense of historical place. Memory of the site as the first industrial venture in the old Transvaal is to be rejuvenated as the programming chosen is rooted within the history of the site. Production is chosen as the driver for the development, and meat production for the dissertation, which is rooted in the present. Therefore a balance between the old and new industry is achieved.

By applying a requalitative design approach, the site can be regenerated without losing important lessons of the past. Avoiding the mistakes of the past through acknowledgement, the present resolution can avoid the same outcome. Where industrial architecture according to Ajanta Sen (2004, p. 8) has to recede and metamorphose, a requalitative or regenerative approach can achieve a progressive nature and not leave future generations with contaminated sites, but rather leave them with a sense of history, place and a functional space of economic value.



Figure - 3.6 - Photograph of existing underground distilling bunkers on site (By Author).

3.5

ADDRESSING THE ENVIRONMENT



Fig - 3.7
Photograph by author.
Building and Nature co-
exist.

BEYOND SUSTAINABILITY - REGENERATIVE ARCHITECTURE

The first hurdle in addressing our dire environmental concerns is the transformation of the built environment from a degenerative typology using obsolete construction technologies to a regenerative architecture. Regenerative architecture is defined as:

“the practice of engaging the natural world as the medium for, and generator of the architecture. It responds to and utilizes the living and natural systems that exist on a site that become the “building blocks” of the architecture.”

(Littman, 2009, p. 3)

The concept of regenerative architecture has two main focusses. Firstly, it focuses on the conservation of the natural environment and secondly it focuses on performance based architecture. The latter is defined as a reduction in the impact of architecture on the environment

(Littman, 2009, p. 3).

The paradigm of sustainability merely addresses the first focus of regenerative architecture and employs patchwork like solutions to the problems. Reducing carbon emissions by applying superficial systems to the surface of the building does not solve the problem but merely postpones the reality of the situation. Why would we only *sustain* our environment for ourselves and not have a productive relationship with it, characterised by a regenerative symbiosis?

“The challenge today is no longer just to create sustainable cities but truly regenerative cities: to assure that they do not just become resource-efficient and low carbon emitting, but that they positively enhance rather than undermine the ecosystem services they receive from beyond their boundaries.”

(Girardet, 2010, p. 1)

Regenerative design aims to surpass the objectives of sustainability and start addressing further reaching avenues, which not only include the natural environment but also the social aspects of the human ecosystem. The architect William McDonough devised a set of principles to guide the designer through a process of regenerative design. These principles were created for the World Exposition in Hannover, Germany in 2002 and are called the Hannover Principles. They are as listed below, from his book *Cradle to Cradle: Remaking the Way We Make Things 2002*:

THE HANNOVER PRINCIPLES

- 1. Insist on rights of humanity and nature to co-exist** in a healthy, supportive, diverse and Sustainable condition.
- 2. Recognize interdependence.** The elements of human design interact with and depend upon the natural world, with broad and diverse implications at every scale. Expand design considerations to recognising even distant effects.
- 3. Respect relationships between spirit and matter.** Consider all aspects of human settlement including community, dwelling, industry and trade in terms of existing and evolving connections between spiritual and material consciousness.
- 4. Accept responsibility for the consequences of design** decisions upon human well-being, the viability of natural systems and their right to co-exist.
- 5. Create safe objects of long-term value.** Do not burden future generations with requirements for maintenance or vigilant administration of potential danger due to the careless creation

The Guardian | Tuesday August 29 2006

National

Engineers race to steal nature's secrets

Giant wind turbines based on a seed, and desalination plant that mimics a beetle

John Vidal
Environment editor

A new generation of small green companies is emerging with radical but proven ideas to revolutionise engineering and create anything from intelligent fridges to colossal wind turbines roooved at sea.

The designers hope their projects will transform energy supplies and cut carbon emissions in the next 20 years. They include huge wind turbines, more powerful than any seen before, anchored to the seabed 20 miles off the coast; fridges that monitor the national grid to use less power; a desalination plant that is also a theatre; and a tidal lagoon that protects the coast while generating electricity.

The new companies are rethinking major infrastructure projects using natural objects as their basis. The aero-generator turbine, now being laboratory tested before sea trials next year, mimics sycamore seeds that spin like propellers in the slightest breeze. Its twin arms could each be as tall as the Eiffel tower, and the structure could be moored like an oil platform in 450 feet of water.

Each turbine, said Martin Pawlyn, an architect with Grimshaw - which developed the transparent "biomes" at the Eden Project in Cornwall - could produce 20 megawatts of electricity, nearly five times as much as any existing wind turbine. "A cluster of 100 of them spread over just a few square miles of ocean, each turning at just a few revolutions a minute, could outperform almost all Britain's existing wind farms put together," he said.

"We are now learning from natural ecosystems, and are scaling up projects. We are going back to first principles, taking our inspiration from nature."

The desalination plant, essential in countries that suffer water shortages, is also being rethought. Mostly banished to the edges of cities, they are disliked for needing large amounts of energy and looking like ill-designed boxes. Architects working with designer Charlie Paton have developed one that needs next to no energy and can double up as an open-air theatre. It has been proposed by Grimshaw for the city of Las Palmas in the Canary Islands, historically short of fresh water.

The structure, looking like a wall of glass and steel, uses simple evaporators and condensers to produce large quantities of fresh water. "The inspiration came from the Namibian fog-basking beetle, which uses its shell as a condensing sur-



Creative energy
Clockwise from main picture: how a desalination plant could double as an open-air theatre; a sea wall that would incorporate tidal and wind generators; a huge wind turbine that would be moored at sea
Illustrations: Grimshaw Architects



face for moisture, which allows it to survive in the desert," said Mr Pawlyn. "There are countless other examples like this that we can turn to when tackling some of the environmental issues that we now face."

The idea has been used in three commercial greenhouses in the Middle East to grow food using salt water. Seawater cools and humidifies the air in the greenhouse and sunlight distils fresh water.

A radical but simple design proposed for north Wales is a 15km-long tidal energy scheme that could generate up to 450 megawatts of power and protect the coastline from erosion and severe storms. It could be constructed from dredged sand and seabed material, or waste slate from disused Welsh quarries. Long rows of hydroelectric generators would turn and generate electricity as the tide rushes in and out. North Wales has some of the highest tidal ranges in the world.

"It would protect Blyth and neighbouring towns with 30 linear miles of breakwater, reducing the risk of flooding disasters like the one in 1990. But it would not be visually intrusive. It works well with wind power, and it would even be possible to move it," said Mr Pawlyn.

The scheme could also offer a natural but nearly invisible shelter, allowing a marina to be built and a depressed area of

'One hundred of these wind turbines could outperform all Britain's existing wind farms'

Martin Pawlyn

north Wales to be regenerated. "We are trying to raise the utilitarian (infrastructure project) to another level. It's the idea of celebrating nature, and learning from it to rethink environmental problems," said Mr Pawlyn.

Other ideas being developed include sewage treatment processes that generate 20% more electricity than usual, and giant solar heaters that would concentrate sunlight on to solar cells, producing 30 times as much electricity as today's cells.

Mark Shorrocks, a director of venture capital firm Low Carbon Accelerator, which is aiming to raise £50m to back dozens of small green technology companies, said the market for imaginative, new renewable energy technologies was taking off, and was expected to more than double in the next few years. Solar energy is expected to be a £50bn market by 2015.

guardian.co.uk/environment

Figure - 3.8 - Article from the Guardian August 29, 2006

of products, processes or standards.

6. Eliminate the concept of waste. Evaluate and optimize the full life-cycle of products and processes, to approach the state of natural systems, in which there is no waste.

7. Rely on natural energy flows. Human designs should, like the living world, derive their creative forces from perpetual solar income. Incorporate this energy efficiently and safely for responsible use.

8. Understand the limitations of design. No human creation lasts forever and design does not solve all problems. Those who create and plan should practice humility in the face of nature. Treat nature as a model and mentor, not as an inconvenience to be evaded or controlled.

The principles listed cover the core and all the basis of the concept of regenerative design. The Hannover principles consider all aspects of human interaction with the built environment, nature and the interdependence of the human settlement.

The Role of Regenerative Architecture in Industrial Development

Regenerative architecture strives to reconnect architecture with its natural landscape and its ecological context to create a relationship not just including the natural but also the social aspects of the building's physical context (Girardet, 2010, p. 9). Industrial architecture has to transform to this vision and adhere to the principles set out by McDonough for it to be incorporated into areas of dense human activity and commerce.

When applied to the industrial typology, the eight principles by McDonough not only address the typologies environmental concerns but also start to outline a new interface between the public and industry. The development of this interface is of utmost importance to unlock the spatial potential of areas of production. For these areas to be wholly integrated into urban and even sub urban areas all of the principles need to be satisfied. Only then can the industrial typology survive constructively within the everyday processes of human activity.

The Role of Regenerative Architecture in South African Cities

"Solutions Grow From Place. Ecological design begins with the intimate knowledge of a particular place. Therefore, it is small scale and direct, responsive to both local conditions and local people. If we are sensitive to the nuances of place, we can inhabit without destroying." (Van Der Ryn, S., & Cowan, S. 1996. p. 39)

Regenerative architecture, just like the TIR (Third Industrial Revolution) takes on new meaning in a third world developing country context like that of South Africa. When looking at the triple bottom line principle of sustainability namely: the economic, environmental and social spheres, the social aspect of sustainability and regenerative design becomes the most weighted in our context. For the economic and environmental spheres to be satisfied in a third world country, the social ills need to be addressed first.

Industry and production supply the majority of our population with income (Anglogold, 2000) and requires a transformation to strengthen its future position as provider for millions of people in South Africa. For industry to secure a productive place in the future economy, the architecture it houses should start addressing not only the environmental needs but also the social needs of its location.

Therefore the role of regenerative architecture in the context of South Africa has to start with the social concerns whilst concurrently addressing the environmental issues, and by successfully doing this the economical sphere shall be satisfied. By applying what Cowan and Van Der Ryn say and looking at a responsive approach to both local conditions and local people, a regenerative and reciprocal relationship can be constructed between the public and the architecture of production.



Figure - 3.9 - Regenerative design - A balance between natural and man made ecosystems

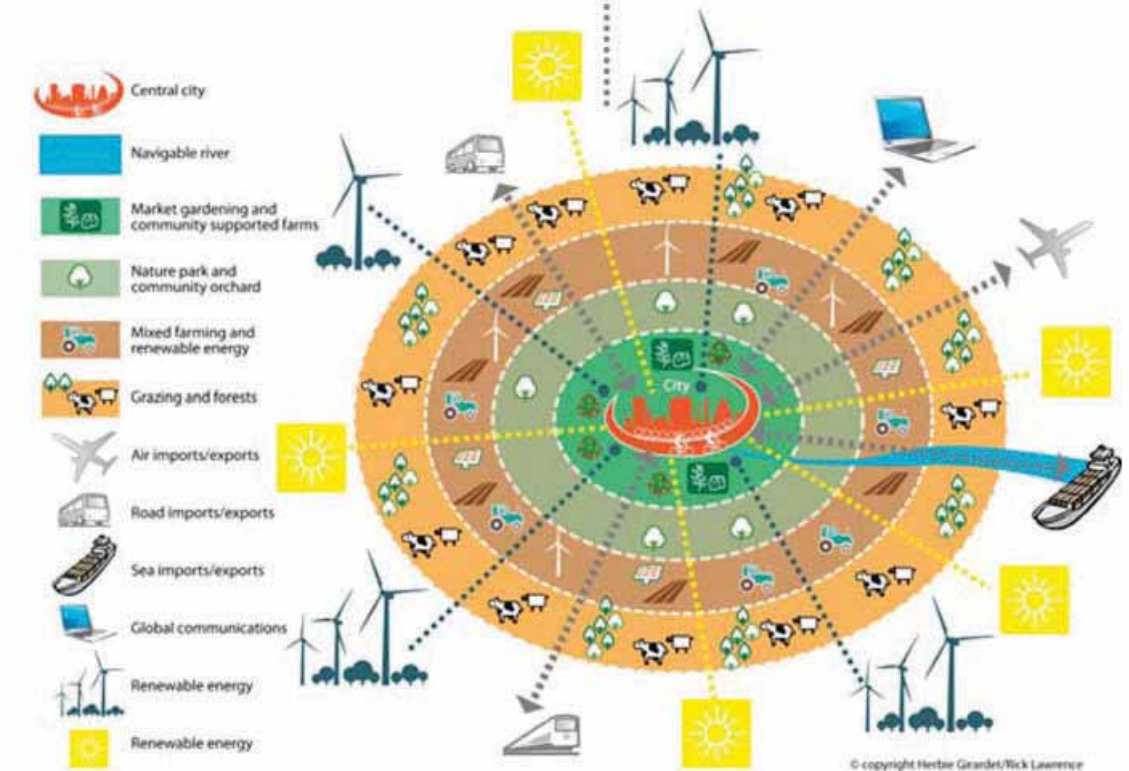

Figure - 3.10 - "The Ecopolis" - Diagram of how regenerative cities work.

THEORETICAL SYNTHESIS

A Required Change for a Static Typology

The Third Industrial Revolution

Heritage: Recycling History and Memory

Beyond Sustainability: Regenerative Architecture

The theory discussed under the four listed headings above follows an argumentative structure of:

1. (3.1) Identifying a problem with the industrial typology.
2. (3.2) Addressing the identified problems with current initiatives.
3. (3.3) Embracing the historical value of deserted industrial sites.
4. (3.4) Making the industrial typology suitable for future generations.

SYNTHESIS

The dissertation argues that static mono functional industrial architecture has led to numerous abandoned industrial sites scattered around the urban periphery. The architecture inhabiting abandoned industrial sites or industrial wastelands, as referred to by Irene Curulli, prohibited abandoned sites from evolving with its ever changing context, be it physical or economical.

A separation between industrial architecture, the landscape, urban surface and productive urban network is identified as another cause for the deserted state of the industrial wasteland. These sites contain large amounts of history memory and embodied energy that can be unlocked.

The dissertation continues to identify the Third Industrial Revolution (TIR) as the current paradigm shift concerning industry, industrial architecture and its future. The TIR requires a new

typology to refrain from repeating the mistakes of the past that lead to the vast amount of abandoned industrial sites.

The new industries surrounding the TIR is found not to be applicable to the South African context just yet, due to the advanced technology and infrastructure required.

By readdressing the current industry and industrial architecture within a sustainable framework, the current industry can provide the infrastructure and foothold for the TIR in the near future.

It is argued that the current method of wiping these sites clean of their heritage and memory is detracting from the city, as these sites support the city's identity. The regeneration of these sites are becoming more important as space in urban centres become less. A series of design principles formulated by Irene Curulli regarding "*requalification design*" is discussed and identified as an applicable tool when working with abandoned industrial sites.

The dissertation argues that the current sustainable paradigm is not enough, as it is preserving an already damaged future and that a further paradigm shift is required to regenerate the environment. The theory of regenerative architecture is agreed upon as the possible solution. The Hannover Principles as formulated by William McDonough are identified as another design tool.

Regenerative architectural theory is discussed in the context of industrial development in South African cities. By applying the Hannover principles to the architecture of industry, a new interface between the public and industry can start to develop, reconnecting the architecture to the productive urban network. Within the South African context, regenerative architecture requires a shift in priorities. It is argued that the social spheres

need to be satisfied before the environmental issues can be addressed. It is identified that by understanding and responding to the local conditions and community, a reciprocal relationship between the public and architecture of production can be achieved.

TOWARDS A REGENERATIVE FUTURE FOR THE ARCHITECTURE OF INDUSTRY.

To create a positive permanence within the architecture of industry, it has been identified that not only the future aims and goals require attention but past and present concerns require consideration. For the architecture of industry to be pulled from its obscure peripheral locations and placed within the public realm, it requires a new methodological approach to the creation of a productive interface.

The interface is to be defined by not only how it connects the building to its physical surroundings, but also how it connects its inherent processes, as there are a multitude of natural and man made energy flows into which it can tap. These energy flows include harnessing the environment to assist the sustainable functioning of the building and also understanding the needs of the community into which it is placed. By allowing the architecture to connect with the community, the building gains functional longevity and can provide economic venture by exploiting the concept of waste. The typology can no longer act as containers, housing abrasive processes and requires reconnecting with all spheres of its context.

The heritage value of abandoned sites requires extreme scrutiny and cognisance to avoid perpetuating the ills of the past. The value of heritage and memory associated with place, requires architectural preservation because it adds to the identity of the region.

The dissertation aims to explore the creation of such an interface between the public and the macabre processes housed in an abattoir. The interface is to be driven by the concept of waste as it aligns itself with regenerative principles and also South African ritualistic processes. By relocating the abattoir into the public realm, it will create a public discourse with people acknowledging what is happening, and no longer being able to keep the reality of the abattoir at arms length.

The intention of this discourse is not to promote vegetarianism but for people to take cognisance of the process, the parts thereof, and possibly stop the over consumption red meat.

4.1

LOCATION



Fig - 4.1
Photograph of historical
remains on site. These
buildings were the old
foreman's homes. By Au-
thor.

CONTEXT

INDUSTRIAL DEVELOPMENT IN PRETORIA - A BRIEF OVERVIEW

The administrative capital of South Africa, Pretoria, has a rich heritage of industrial development which shaped the physical growth of the city. In 1855 Pretoria was established as a municipality which makes it the oldest manufacturing center in the old Transvaal (now Gauteng).

By 1955, Pretoria's industry produced 30% of the country's total industrial output. This rapid industrial development was not only due to extreme human enterprise but due to the geographical location of the city (Unknown, 1955, p. 99). The occurrence of basic raw materials within close proximity and the rail and road connections with domestic and foreign markets made it an ideal place for the modern industrialist. Pretoria forms part of the Witwatersrand industrial complex which comprises Johannesburg, The East and West Rand and Vereeniging. By the 1960's this industrial complex served 2.5 million people within a 115 kilometre radius (Stark, 1955).

Pretoria's close proximity to iron ore and coal, resulted in ISCOR (now MITTAL) being established here. ISCOR became South Africa's largest steel manufacturer and took local production of steel from 18% to 90 percent within 15 years of its opening in 1934 (Unknown, 1955).

Local government also aided the industrial progression by developing support services for the industrialist, such as the SABS (South African Bureau of Standards) and the CSIR (Council for Scientific and Industrial Research). This growing industry forced other sectors to upgrade and expand, such as the rail network which by 1950 became the 4th largest in the Union. By the 1960's there was no more space to repair coaches and the government undertook the construction of new workshops

at Koedoespoort; at the time was the largest rail maintenance workshops in the Southern Hemisphere. (Stark, 1955, p. 100)

The steel industry may be the most significant in the development of industrial Pretoria but there were/ are a few other industries that also played significant roles. The Kirkness brick making yards, situated in Groenkloof which had an annual output of 50 million bricks and the development of Portland Cement at Daspoortrand which was the first of its kind in South Africa (Unknown, 1955, p. 54).

By the late 1950's the local government wanted to develop secondary industry in Pretoria and located a new industrial development area about 10km north of the city centre, known today as Rosslyn. This was the start of the industrial sprawl which was later to become the cause of industrial wastelands around the periphery of Pretoria.

Industrial development forms a large part of Pretoria's heritage, but is somewhat overshadowed by Pretoria's eventful political past. When entering Pretoria from the west, there is some poetic justice in the fact that not only the Voortrekker Monument is visible perched on the hill, but by its feet the ISCOR complex grinds on (Stark, 1955, p. 33).

In 1873 after the discovery of gold at Pilgrim's Rest, Hungarian industrialist Alois Hugo Nellmapius came to Pretoria to pursue his fortune. After many small enterprises in 1881 he received the sole right to manufacture alcoholic beverages from President Kruger and met with businessman Sammy Marks to establish the first distillery in Pretoria. In 1883 the Eerste Fabrieke Hatherly Distillery opened in Vlakkfontein (now Mamelodi). The Eerste Fabrieke complex expanded further when in 1895 the South African Fruit and Meat Preserves Company opened next to the distillery and was later joined by the Consolidated Glass

Works Company in 1896. Eerste Fabrieke Hatherly was the first industrial development in Pretoria and set the tone for future industrial development (Kaye, 1978, p. 3).

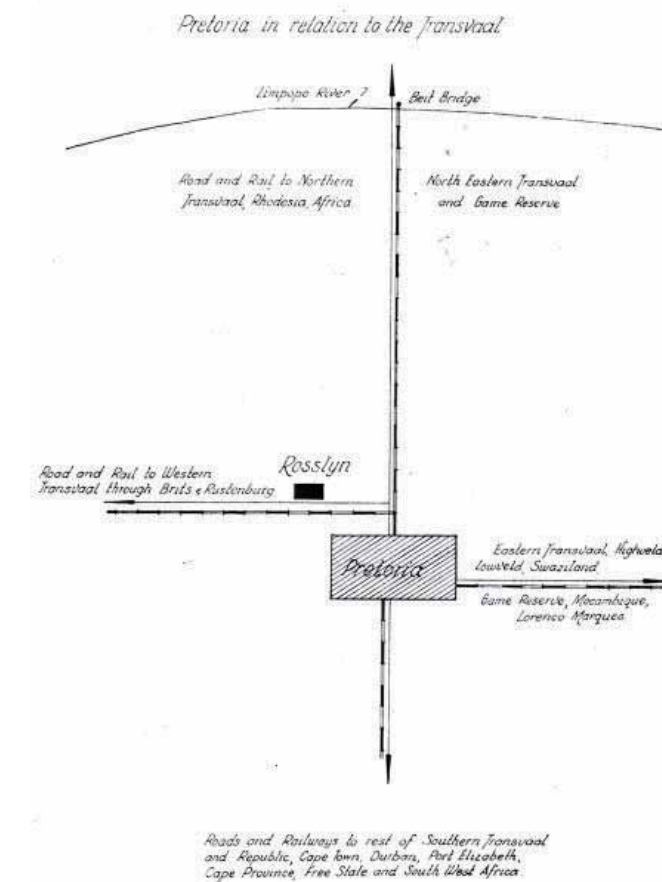

Figure - 4.2 - Rail and Road network in Pretoria 1955

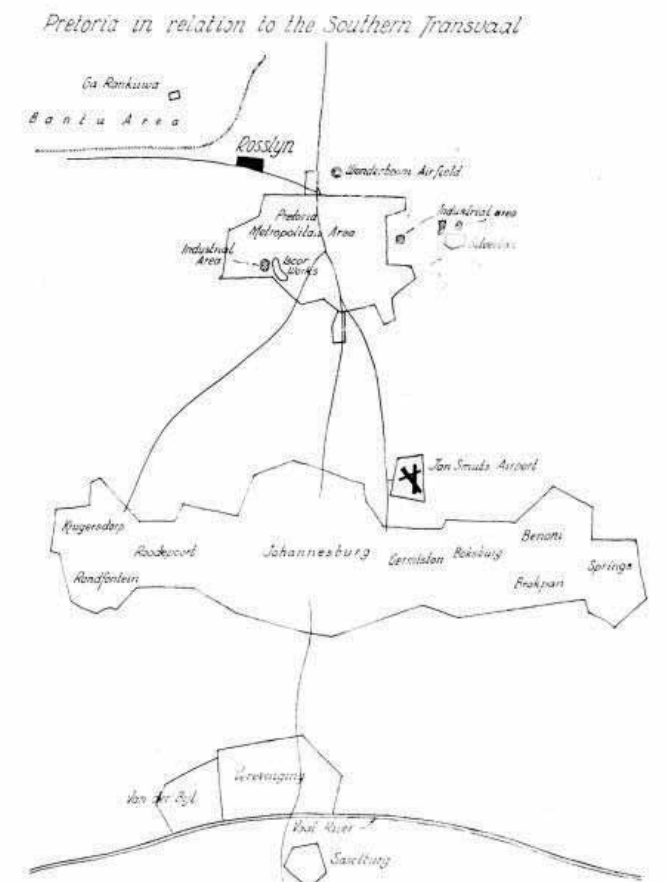

Figure - 4.3 - Witwatersrand Industrial complex



Figure - 4.4 - Pretoria West Power Station initiated industrial development

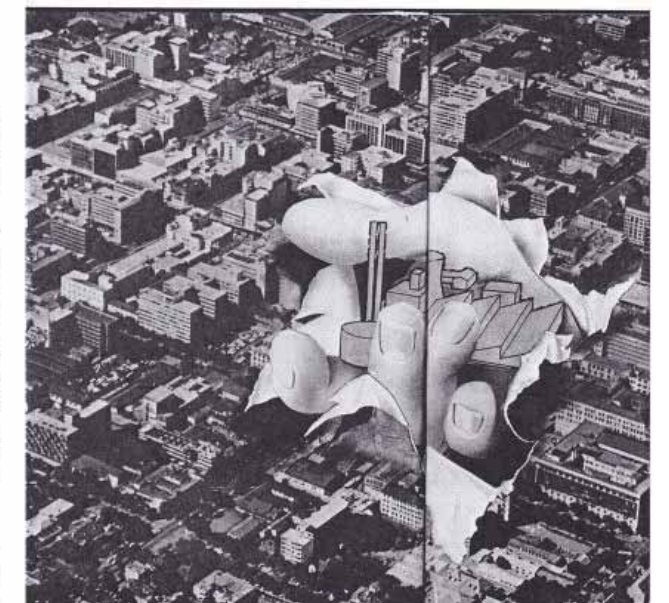

Figure 4.5 - Image from 1955 - Pretoria and Industry

SETTING

SITE SELECTION CRITERIA

The following criteria were established to focus the selection of site. The criteria aim to address a typology of site that can act as a canvas on which the hypothesis and sub problems of the dissertation can be tested.

The site should have rich industrial heritage.

Only brownfield sites will be considered.

The site should have existing infrastructure: transportation and basic services.

The site should be well connected to neighbouring communities.

There must be future initiatives for development on the site.

SITE SELECTION

The investigation started by looking for sites close to the CBD of the CoT (City of Tshwane). The search led to the area of Pretoria West which is characterised by secondary industry that has mostly become defunct and derelict. Pretoria West was considered and measured against the criteria but finally disregarded due to the lack of connection to local communities and no future development initiatives of substance. Further investigation found a site in the Eastern precinct of Tshwane called Mamelodi, where all the criteria were met and a site called Eerste Fabrieke Station Precinct was finally chosen.



Figure - 4.6 - Africa with South Africa as indicated (By Author)



Figure - 4.7 - South Africa with Tshwane as indicated (By Author).



Figure - 4.8 - City of Tshwane with Mamelodi as indicated (By Author).



PROJECT LOCATION

WHY MAMELODI AND EERSTE FABRIEKE?

The site is well connected to transport infrastructure: Love Drive and Eerste Fabrieke Train station borders the site

The site has a very strong industrial heritage; it is where the first industrial building in the old Transvaal was built, namely the Eerste Fabrieke Hatherly Distillery.

The site has lost all industry related production and is now used for cattle farming, therefore making it a brownfield site.

The site is bordered by communities such as Mamelodi to the north and Nellmapius to the south making it a intersection between the two.

GAPP has developed a framework for the Mamelodi and Nellmapius area called the Tsosoloso Program, which includes developmental framework for the site and its surroundings.

SITE ANALYSIS

The Eerste Fabrieke site is currently occupied by a cattle farm which covers the entire heritage area as well as more land to the East. There are only a few remains of the original Eerste Fabrieke factory which consist of underground vaulted tunnels in which the alcoholic beverages were distilled, some foundations of the Consolidated Glass works and some houses dating back to the founding of the distillery in 1883.

The rail forms the site boundary to the north with the Eerste Fabrieke station located on the site. The southern and western boundaries of the site are defined by the Pienaars River, and the eastern boundary is defined by the proposed new Hans Strijdom Precinct.

The Nellmapius Township has extended north and almost meets

with the Pienaars River which forms the Southern boundary of the Eerste Fabrieke complex.

PROBLEMS

The site acts as a wedge between Mamelodi west on the northern side and Nellmapius on the southern side. This is due to the site being occupied for agricultural purposes and is therefore disconnected from the urban network.

The railway line on the northern side of the site and the Pienaars River on the southern side, act as physical barriers that restrict access to the site. There is only one way to and from the site and that is via a deteriorated dirt road which connects with Love Drive and travels underneath the railway line to Tsemaya Road. The road is in such a bad condition that travelling is slow and dangerous.

The site is a prime location for the connection of Mamelodi West and Nellmapius North, but due to the physical barriers and limited access, the site lays dormant and acts as a divide rather than the connecting tissue required.

OPPORTUNITIES

The site forms part of the new spatial development framework designed by GAPP. The fact that the site is well serviced with infrastructure, namely the Eerste Fabrieke Train Station, and is in close proximity to other large vehicular routes, makes it ideal for nodal development.

The abattoir will act as a catalyst for future develop-

Figure - 4.10 - Photograph of cattle grazing in large amounts of rubbish found along the streets of Mamelodi (By Author).

ment on site and will support a series of small business incubators which will produce from the waste of the abattoir. The entire animal carcass can be recycled to produce a myriad of products.

The abattoir and the small business incubators can provide the infrastructure for future growth on the site. The site is to become a production centre which will supply the local community with employment and will establish a local economy within Mamelodi and Nellmapius. The production centre will become the binding fabric between Mamelodi and Nellmapius and will become a production node within the spatial development framework proposed by GAPP.

4.3



The site within its context:

1. Eerste Fabrieke Station
2. Flood plane - Green corridor
3. Tsamaya Road Precinct
4. Educational Facility
5. Nellmapius Extension 4
6. Pienaars River
7. Nellmapius Extension 3
8. Love Drive Precinct
9. Hans Strijdom Precinct
10. Dump Site
11. Pienaarspoort Precinct
12. Mamelodi
13. Project Location

Figure - 4.11 - Aerial photograph of the Mamelodi Area.



The site within its context:

1. Eerste Fabrieke Station Platform
2. Eerste Fabrieke Station
3. Historical Houses
4. Historical Outbuildings
5. Love Drive
6. Historical remains of underground storage of distillery
7. Cattle Farm
8. Informal Settlement
9. Historical Building Remains
10. Pienaars River
11. Open Field

Figure - 4.12 - Aerial photograph of the Eerste Fabrieke area.



Figure 4.13 - Heritage on site.

OnSite

All photos by author.



Underground tunnels that was used for distilling

Foundations of the original distillery



Deserted office building against station



House dating back to distillery

Love Drive access route



Outbuilding dating back to founding of distillery



House dating back to distillery

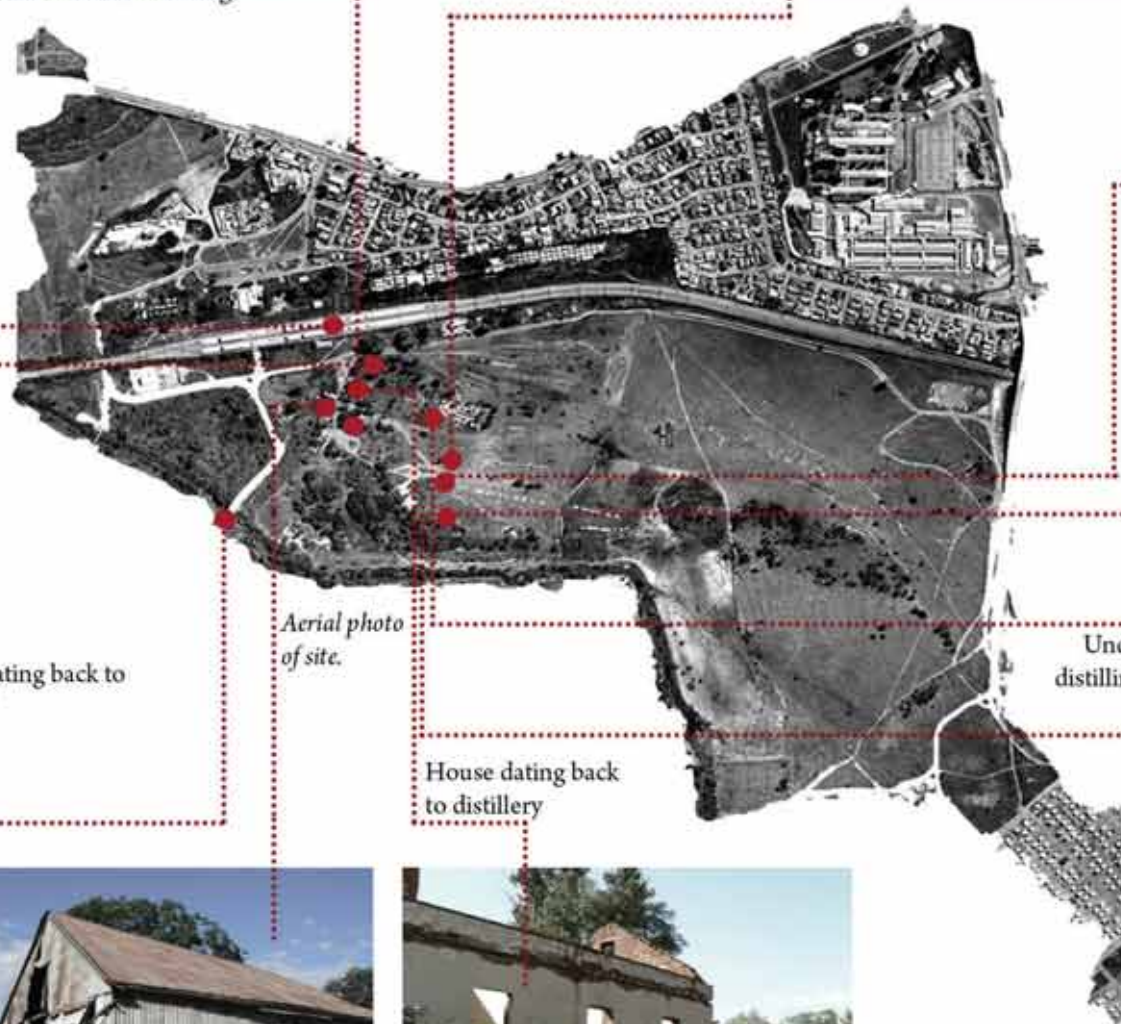

Aerial photo of site.



Foundation walls of outbuilding dating back to distillery



Underground distilling tunnels



Underground distilling tunnels



Underground distilling tunnels

Refer to Timeline on p. 82 & 83 for historical information.

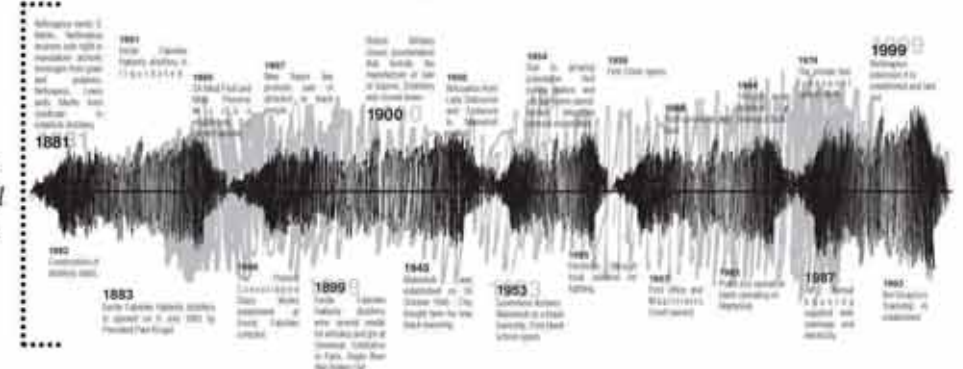

BACKGROUND OF MAMELODI

Mamelodi is a black township founded in 1945 under the apartheid regime, situated on the eastern edge of the CoT. The earliest proof of habitation in Mamelodi is of 1854 when it was still known as a farm called Vlakfontein. In 1874 the Vlakfontein farm was divided into three parts with Part one forming south east Mamelodi as it is known today, part 2 is situated at the foot of the Magaliesberg - Mamelodi north, and part 3 is Mamelodi west (J. Walker, 1991, p. 3).

Townships were residential areas created for non - white citizens between 1905-1960 and are still situated on the periphery of the city. These residential areas were separated from the white residential areas by industrial buffer zones. In the case of Mamelodi, the industrial area of Silverton is positioned between it and the CBD of Pretoria, separating it from the white residential areas. (Breed, 2003, p. 1)

Townships were formed by the apartheid city planning logic, which according to Breed (2011) is characterised by the following:

1. Racial separation of residential areas by highways, industrial areas and railway lines.
2. White residential areas located on prime land with natural resources close to the CBD.
3. Black townships were located on the periphery farthest from the CBD and cut off from it by means of buffer zones.
4. Access from the townships to the CBD was mostly through the rail system.

The government created a series of acts to support the creation of townships. These acts were:

The Natives Land Act of 1913. Blacks were allocated corresponding ethnic 'homelands' or reserves to live in and any purchase or lease of land by blacks outside these homelands was prohibited.

The Population Registration Act of 1950 classified every South African by race: whites (from European descent), blacks (from African descent), coloureds (persons of mixed race) and Indians (from Southern Asia).

The Group Areas Act of 1950 reinforced in 1966, established residential and business sections in urban areas for each race; members from other races could not live, operate a business or own land in these areas. (Breed, Mamelodi Presentation, 2011).

By 1950 black people were relocated from the mixed race area of Lady Selbourne, which was one of a few urban areas where black citizens could have property rights, to Mamelodi. In 1958 Lady Selbourne was declared a white area and all black residents had to move either to Mamelodi or other peripheral townships (J. Walker, 1991, p. 1). In 1968 all development in Mamelodi halted because of the influx of many non white people from the countryside and due to this people were forced to move to Bophuthatswana, a homeland/reserve, about 40 kilometers from Pretoria (Breed, 2011).

Today, Mamelodi is a vibrant mixed race community which is still suffering from the apartheid planning of the 1940's. The area has grown to a population of 359122 residents, which is causing the inherent problems to amplify. The area still suffers from a lack of services and service delivery. There is also a lack of local economy in Mamelodi. This is caused by the planning problems within Mamelodi which discourages investment due to the disconnected nature of the place. This will be addressed further in the framework proposal by GAPP. A few statistics regarding Mamelodi:

4.4

Demographics

Total population: 359 122

Households: 106 670

Ave household size: 3.4

Ave pop. density: 9 415.5 p/ km²

Household density: 2 835.7 hh/km²

Income less than R30 000 p/a: 60%

Income - none: 23% (of the 60%)

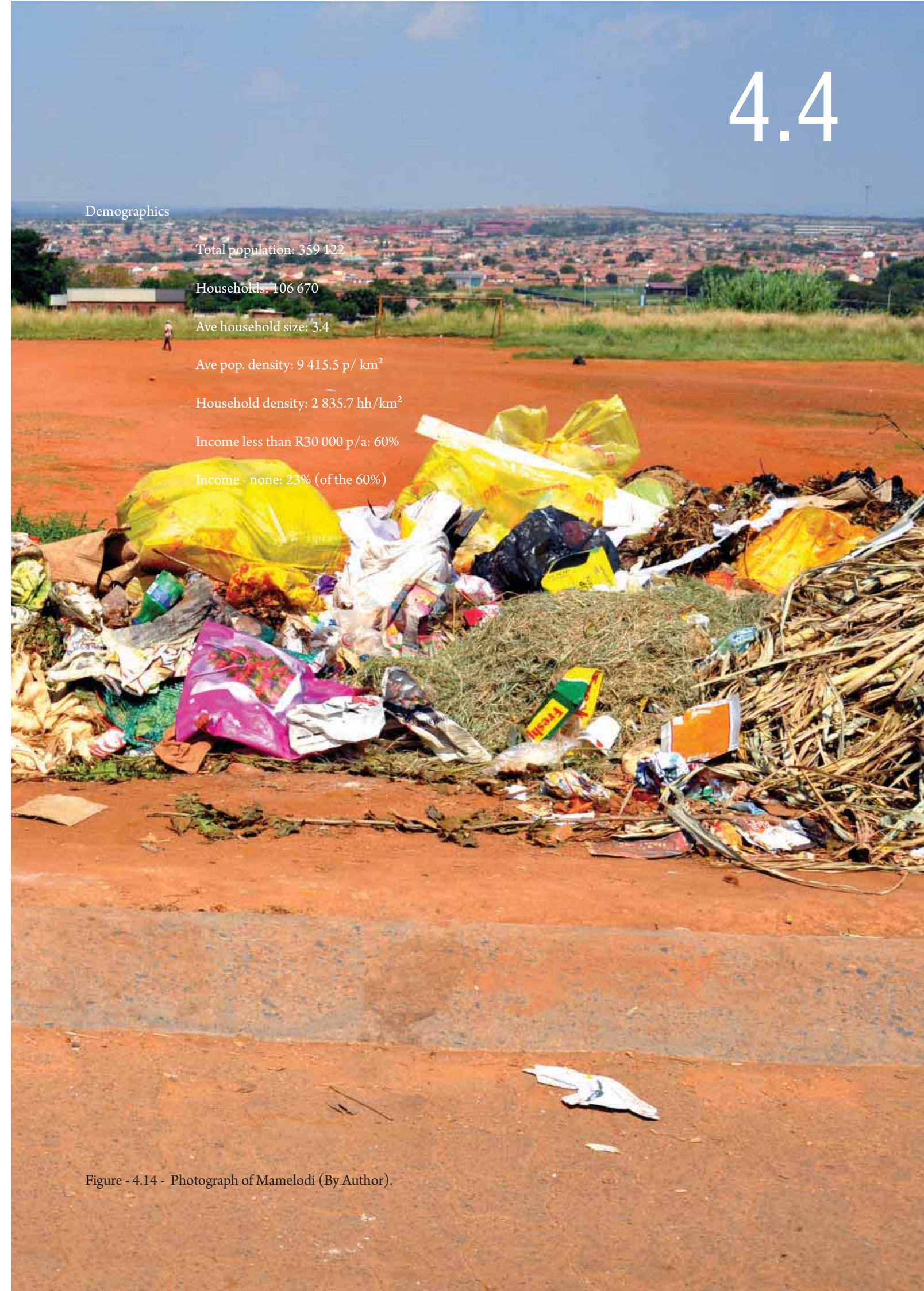

Figure - 4.14 - Photograph of Mamelodi (By Author).

DEVELOPMENT OF MAMELODI

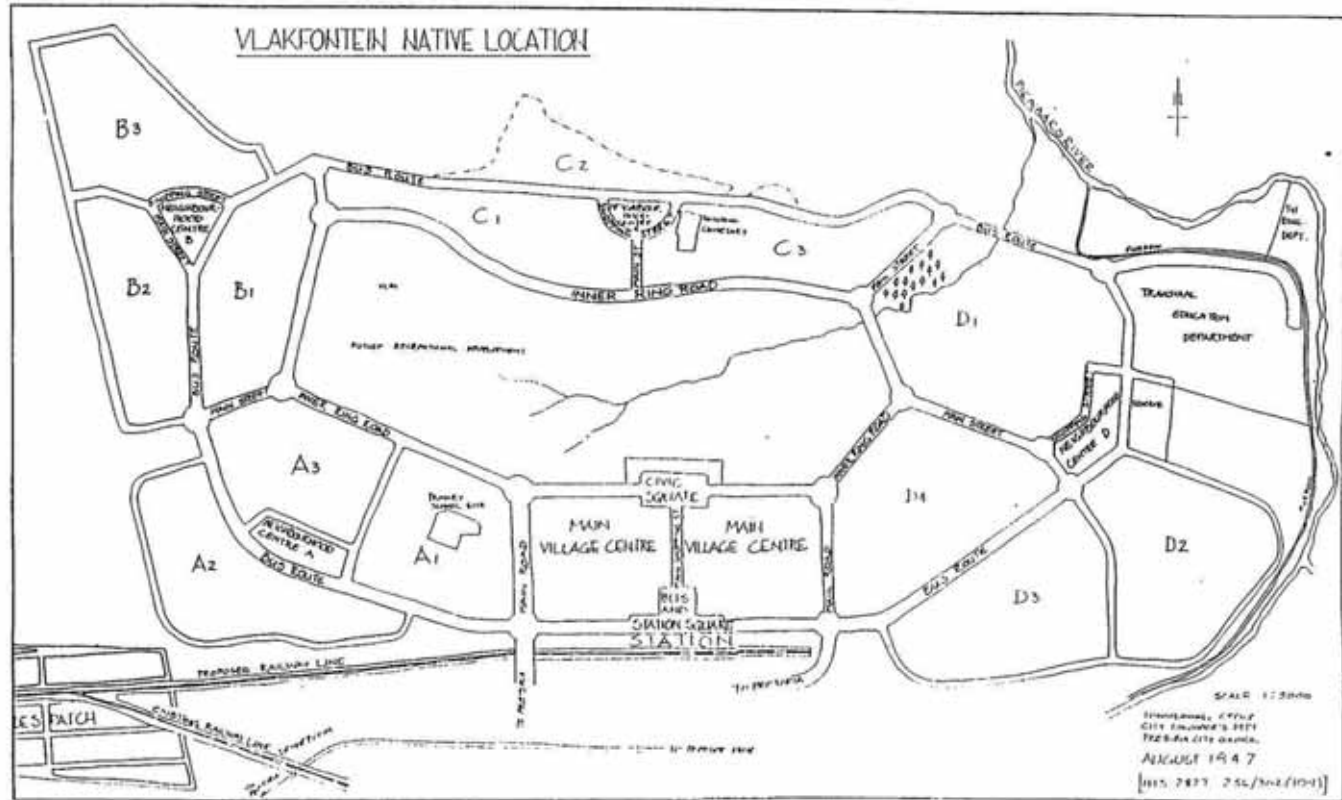

Figure - 4.15 - Layout prior to the establishment of Mamelodi.

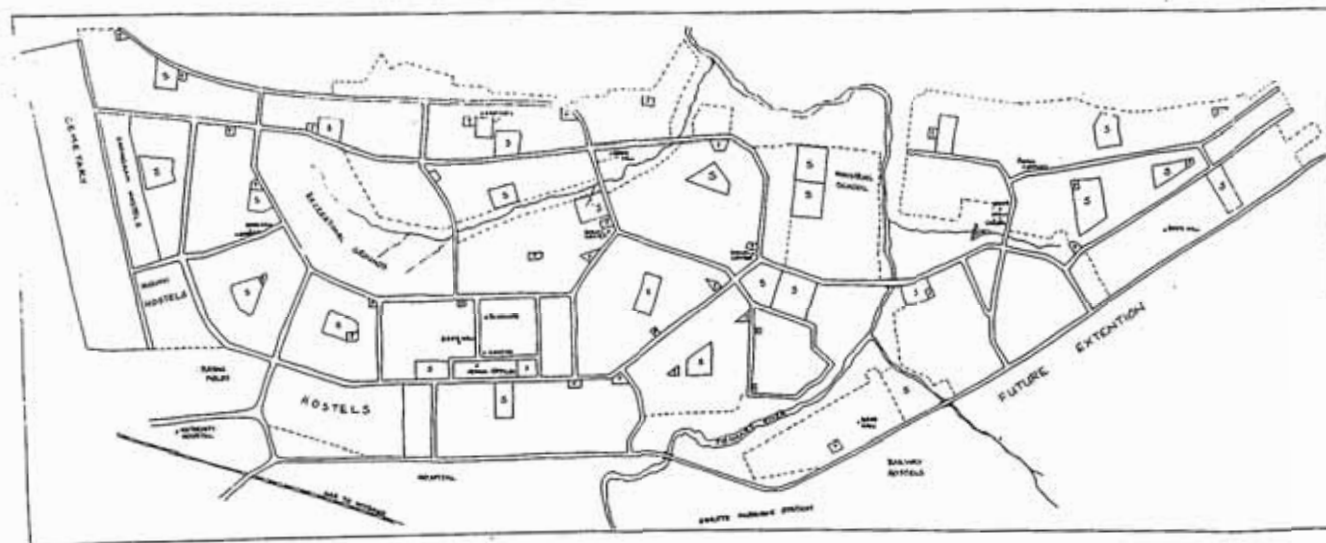

Figure - 4.16 - Old Map of the original layout of Mamelodi (1961).

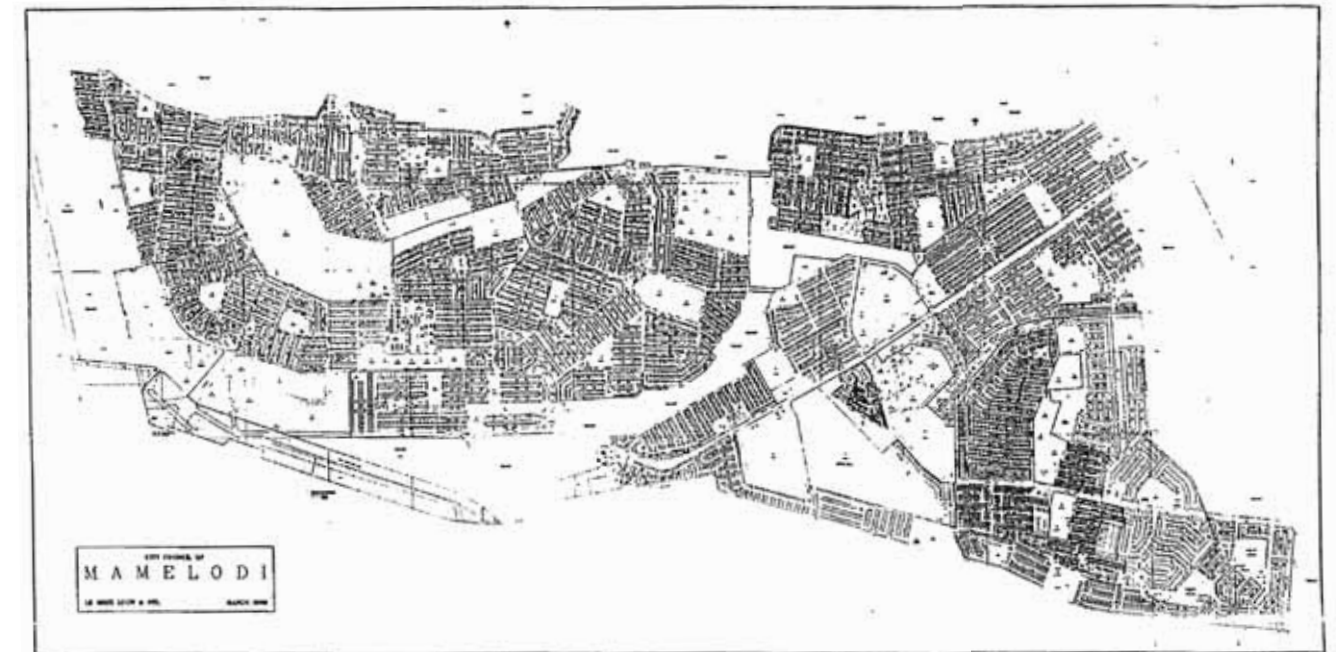

Figure - 4.17 - Survey of built fabric (1970).

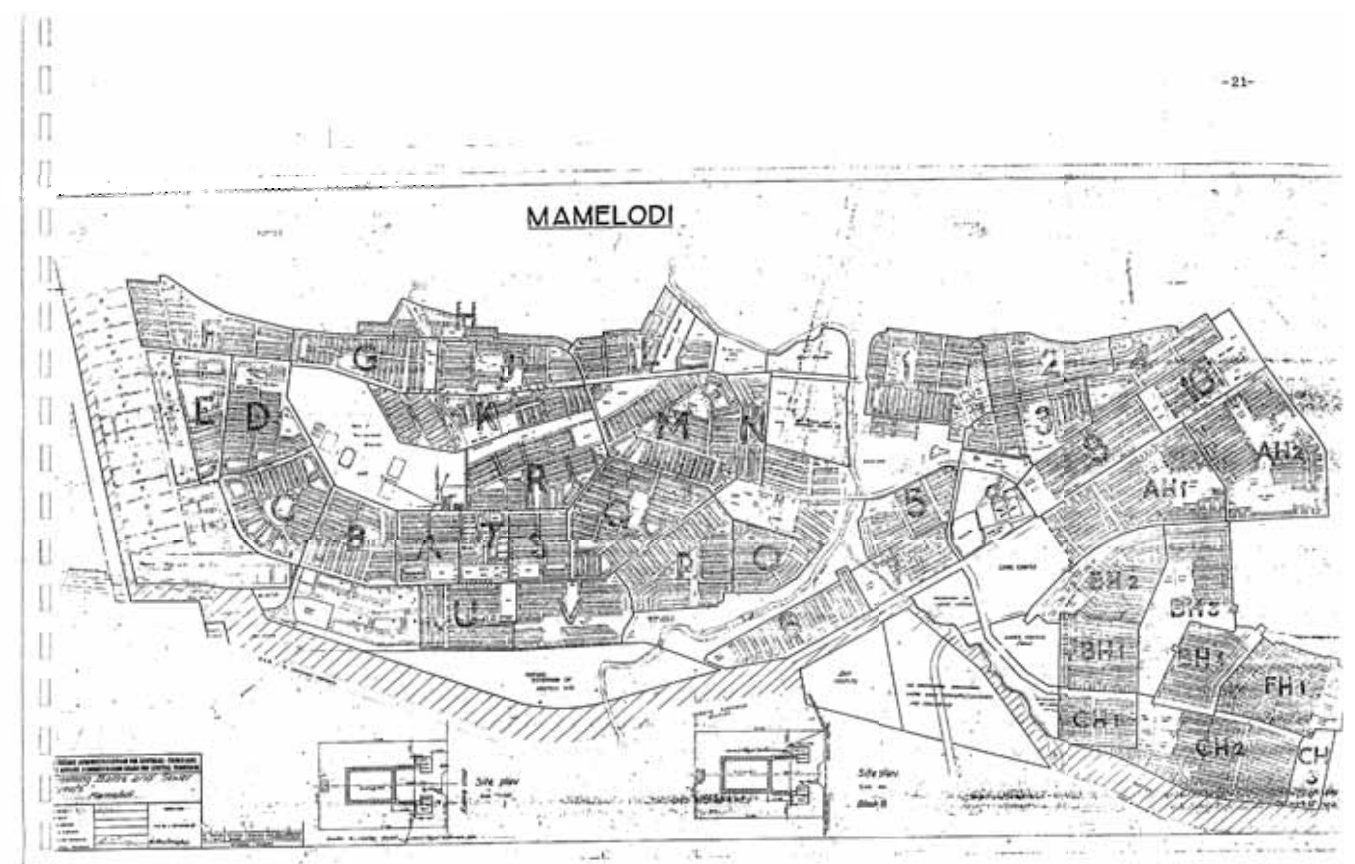
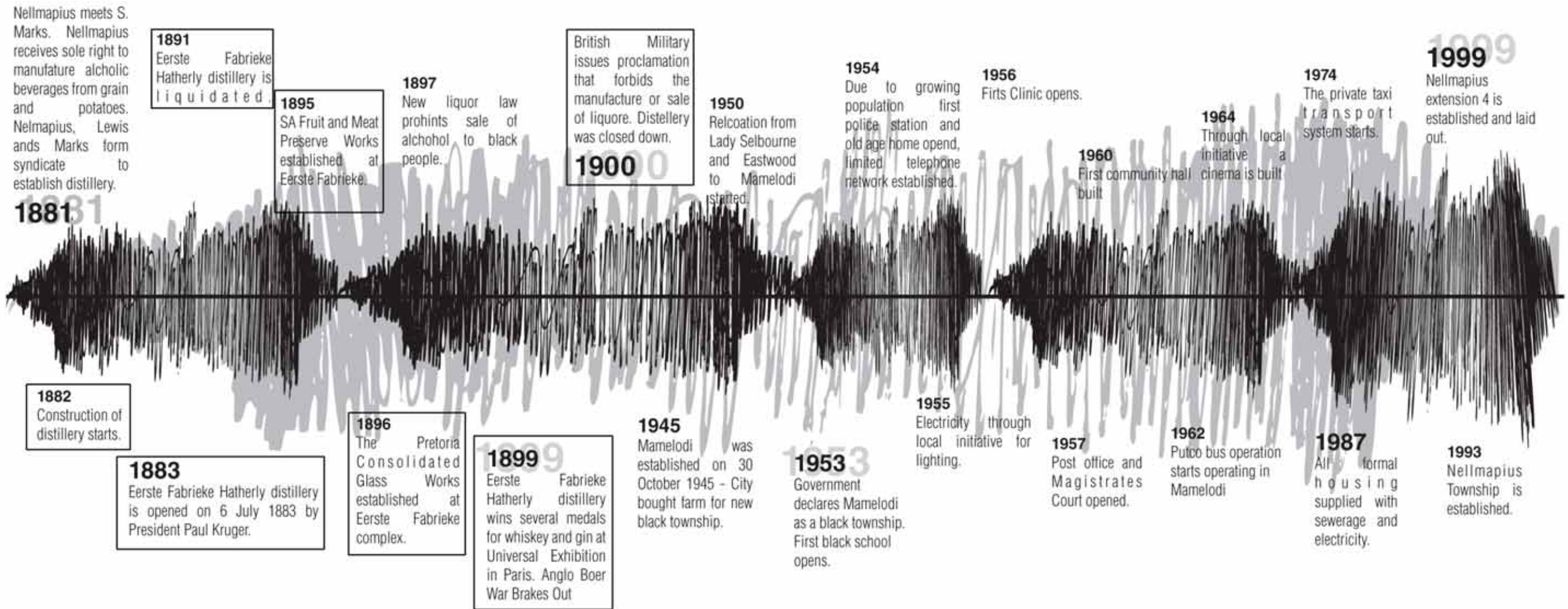

Figure - 4.18 - Final Layout (1976).



Source: (Kaye, 1978. p 4-30.)

Figure - 4.19 - Timeline of important events in Mamelodi (By Author).



Figure - 5.1 - Photograph of cattle being processed in the Rietvlei Abattoir (By Author).

URBAN CRITIQUE - MIND THE GAPP

An urban framework called the *Tsotoso Program* was submitted to the COT council in February of 2011 by GAPP. This programme focuses on the urban spatial redevelopment of the selected and greater study area of Mamelodi and Nelmapius.

STRATEGY AND MECHANISMS

The GAPP spatial development plan proposes a string bead like nodal development called the *City Structuring Model* across Mamelodi building on existing nodes and corridors for future development. The five proposed strategic outcomes of the Tsotoso Programme are to:

- Create community activity centres and focal points (nodes)
- Strengthen activity linkages (spines/corridors)
- Transform transport interchanges into civic termini
- Enhance the pedestrian environment
- Enrich the public environment

The proposal consists of 13 formal nodes across Mamelodi, Nelmapius and Eerste Rust whilst utilising six existing movement corridors, connecting these nodes and proposing a seventh corridor connecting Mamelodi Central to Nelmapius extension 4. The programme extends the development of Nelmapius extension 3 and 4 south from the rail to connect to Hans Strijdom Drive which is outlined as an activity spine.

The proposal further aims to stimulate economic activity through grouping appropriate land uses into hierarchal nodes linked by activity corridors:

Making facilities and services easily accessible by public transport and pedestrian movement.

Providing road and service infrastructure.

Allowing for self generation of economy and attracting investment.

Catalytically allowing a spill over effect into neighbouring districts.

And in turn aid in the development of:

- An hierarchical road network
- Retail, Commerce and Manufacturing
- Residential Areas
- Social and Community Facilities
- Public Transport and Connections
- An Open Space Network
- Service Infrastructure

The proposal outlines a series of precincts associated with the new and existing nodes. These nodes are as follows:

- Tsamaya Road
- Metropolitan Core
- Precinct Max City
- Pienaarspoort
- Love Drive**
- Swartkoppies

5.1



Figure - 5.2 - The Nodal development as proposed by GAPP.



Figure - 5.3 - Proposed node, activity spines and areas by GAPP.

GAPP PROPOSAL FOR STUDY AREA

The chosen site for the dissertation falls within the Love Drive precinct as outlined by the GAPP proposal. The following is a brief summary of the GAPP proposal for the selected study area.

EERSTE FABRIEKE PRECINCT - MACRO CONTEXT

Eerste Fabrieke Station, Pienaars River and Tsemaya road form barriers in and around the site.

Site forms node between Nellmapius and Mamelodi.

Proposal utilises the rail and Tsemaya road to connect nodes.

Development to Nellmapius through Love Drive and finally connects to Hans Strijdom.

Development to the north is unrealistic - development does not happen in such a pattern.

High Street proposal on Eerste Fabrieke site - to be utilised.

EERSTE FABRIEKE PRECINCT PROPOSAL BY GAPP - MICRO CONTEXT

PROBLEMS

Majority of proposal is high density housing.

Layout of proposal not an economic use of land.

Lacks connection to Nellmapius.

Site does not connect Nellmapius and Mamelodi.

The important heritage of the site is not celebrated.

The proposal does not utilise the site's privileged position.



Figure - 5.4 - Proposal for the chosen working area by GAPP.



Figure - 5.5 - GAPP proposes medium and high density housing for the chosen site and under utilises the importance of the site.

URBAN DESIGN

STRATEGIES AND MECHANISMS

The dissertation proposes a new development for the entire Eerste Fabrieke station site which will continue the developmental trend set by the GAPP proposal. The framework for development will be based on the following interventions as proposed by GAPP:

Nodes

Activity spines

Public open space/public environment

These interventions aim to:

To establish clustering, linkages, consolidation and a collective development effort. This enables the establishment of a significant economic threshold.

They either comprise a cluster of projects that form one whole and are interdependent or a single project.

Eerste Fabrieke Precinct - Framework Proposal

INTRODUCTION

The framework proposal will adhere to a brief set up after the investigation was made of the Tsosoloso Program proposed by GAPP. The brief aims to address pertinent issues within the GAPP proposal and explore further mechanisms and strategies for future development in and around the Eerste Fabrieke site.

FRAMEWORK BRIEF

Utilise existing Infrastructure around Eerste Fabrieke Station.

Use heritage as generator for urban development.

Site forms node for possible southern connection to Nellmapius.

Restructure the proposed layout done by GAPP & include more diverse programming.

Site to become production node.

Small Business Incubation model to be investigated to initiate development on site.

Site to be a mix of Industry, commerce and high and medium density housing.

Bridging connections from Nellmapius over the Pienaars River to increase pedestrian access.

New layout of site to be investigated - more economical use of land.

Propose more development along Love Drive and Pienaars River to the south.

Existing cattle farm to be moved to the west, opposite the Pienaars River.

After the compilation of the brief, research was done regarding the historical development of the Eerste Fabrieke precinct and what possible design generators could emerge from the site's history.

HISTORICAL DEVELOPMENT OF SITE

The Eerste Fabrieke Hatherly distillery complex was developed on this specific site due to its connection to the rail and to the Pienaars River. Production on site made use of the Pienaars River in the distillery process and later in the glass works.

The distillery complex was developed around a ceremonial

Figure - 5.6 (Right)- 1937 Aerial photograph of the Eerste Fabrieke precinct indicating the first industrial complex.



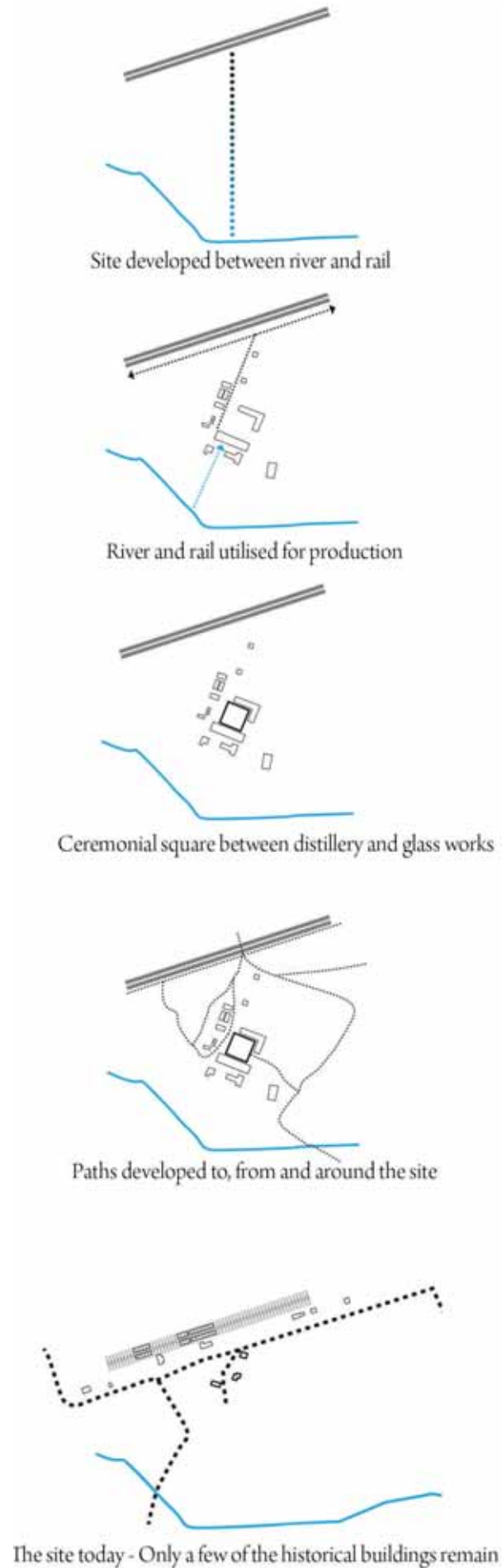
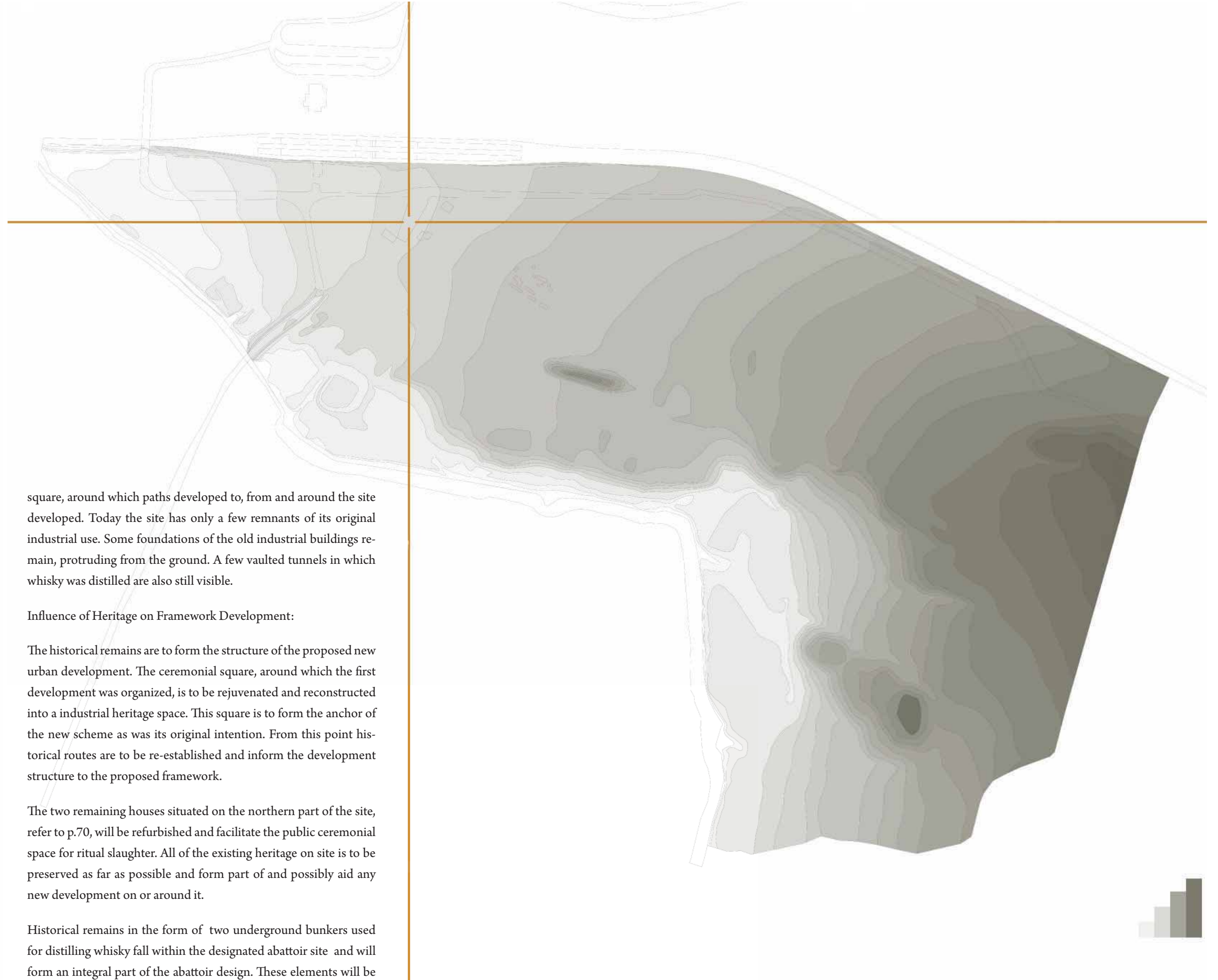

Figure - 5.7 - Historical development of site (By Author).



square, around which paths developed to, from and around the site developed. Today the site has only a few remnants of its original industrial use. Some foundations of the old industrial buildings remain, protruding from the ground. A few vaulted tunnels in which whisky was distilled are also still visible.

Influence of Heritage on Framework Development:

The historical remains are to form the structure of the proposed new urban development. The ceremonial square, around which the first development was organized, is to be rejuvenated and reconstructed into a industrial heritage space. This square is to form the anchor of the new scheme as was its original intention. From this point historical routes are to be re-established and inform the development structure to the proposed framework.

The two remaining houses situated on the northern part of the site, refer to p.70, will be refurbished and facilitate the public ceremonial space for ritual slaughter. All of the existing heritage on site is to be preserved as far as possible and form part of and possibly aid any new development on or around it.

Historical remains in the form of two underground bunkers used for distilling whisky fall within the designated abattoir site and will form an integral part of the abattoir design. These elements will be further discussed in the design development chapter (8).

Figure - 5.8 - The topographical characteristics of the site - falling towards the Pienaars River (By Author).



Figure - 5.9 - The urban proposal for the Eerste Fabrieke Precinct (By Author).

FRAMEWORK PROPOSAL

PART 1: INITIATION

The framework proposal focuses on a nodal development based on the historical structure of the site. Nodes are placed along old pedestrian routes and old site nodes such as the ceremonial square. The framework aims, through nodal development, to connect Nellmapius extension 3 & 4 and connect Mamelodi to Nellmapius through the Eerste Fabrieke precinct site. The proposal keeps the existing high street proposal by GAPP with the Tsosoloso Programme which runs parallel to the rail on the northern edge of the site.

The structure of the framework layout adds two new connections to the existing Love Drive connection, one across the Pienaars River to Nellmapius extension 4 and one to the east, connecting to Nellmapius extension 3. A further pedestrian connection is made to Mamelodi through a submerged pedestrian tunnel underneath the railway to the north.

The proposal consists of ten nodes with activity spines and corridors connecting them. The nodes are to be conceived as a public square of mixed use function and tri modal transportation interchanges. Ten nodes make up the proposal, their programming is as follows:

Node 1: Love Drive Node - Entrance to graveyard and cattle farm precinct to west, entrance to Nellmapius North to East.

Node 2: Heritage Square - Rebirth of old ceremonial distillery square, now to become a square celebrating the industrial heritage of the site. This can become a tourist node.

Node 3: Eerste Fabrieke Square - Pedestrian entrance/exit to and from Mamelodi, underneath rail. It is located on the old railway crossing to Mamelodi.

Node 4: Production Node 1 - Situated on old route across site

dating back to the distillery, becomes production node via small business incubation supported by abattoir.

Node 5: Production Node 2 - Also situated along old pedestrian route along site, the node also becomes a small business incubation hub supported by the abattoir.

Node 6: Mixed Use Node 1 - along connecting axis to new Nellmapius East residential development, node consists of mixed use, commercial, production and high density residential development.

Node 7: Mixed Use Node 2 - along connecting axis to new Nellmapius East residential development, node consists of mixed - use, commercial, production and medium density residential development.

Node 8-10: Residential Node - along connecting axis to new Nellmapius East residential development which connects with Nellmapius extension 3, node consists of mixed use, commercial & medium density residential development.

Node 9: Crossing Node: The node acts as a river crossing connecting to Nellmapius ext. 4, node is situated in the green belt along the river, recreational development will happen around this node.

Node 10: Production Node: This node extends the production of the Eerste Fabrieke Precinct into the Nellmapius ext. 4 area.

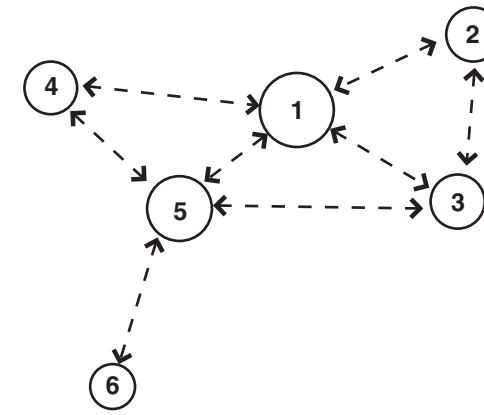

Figure - 5.10 - Concept - Initiation

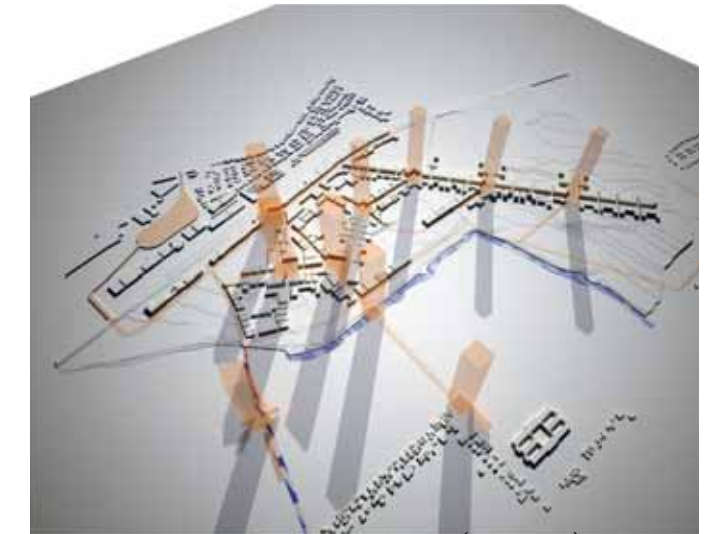

Figure - 5.11 - Conceptual render of nodes (By Author).

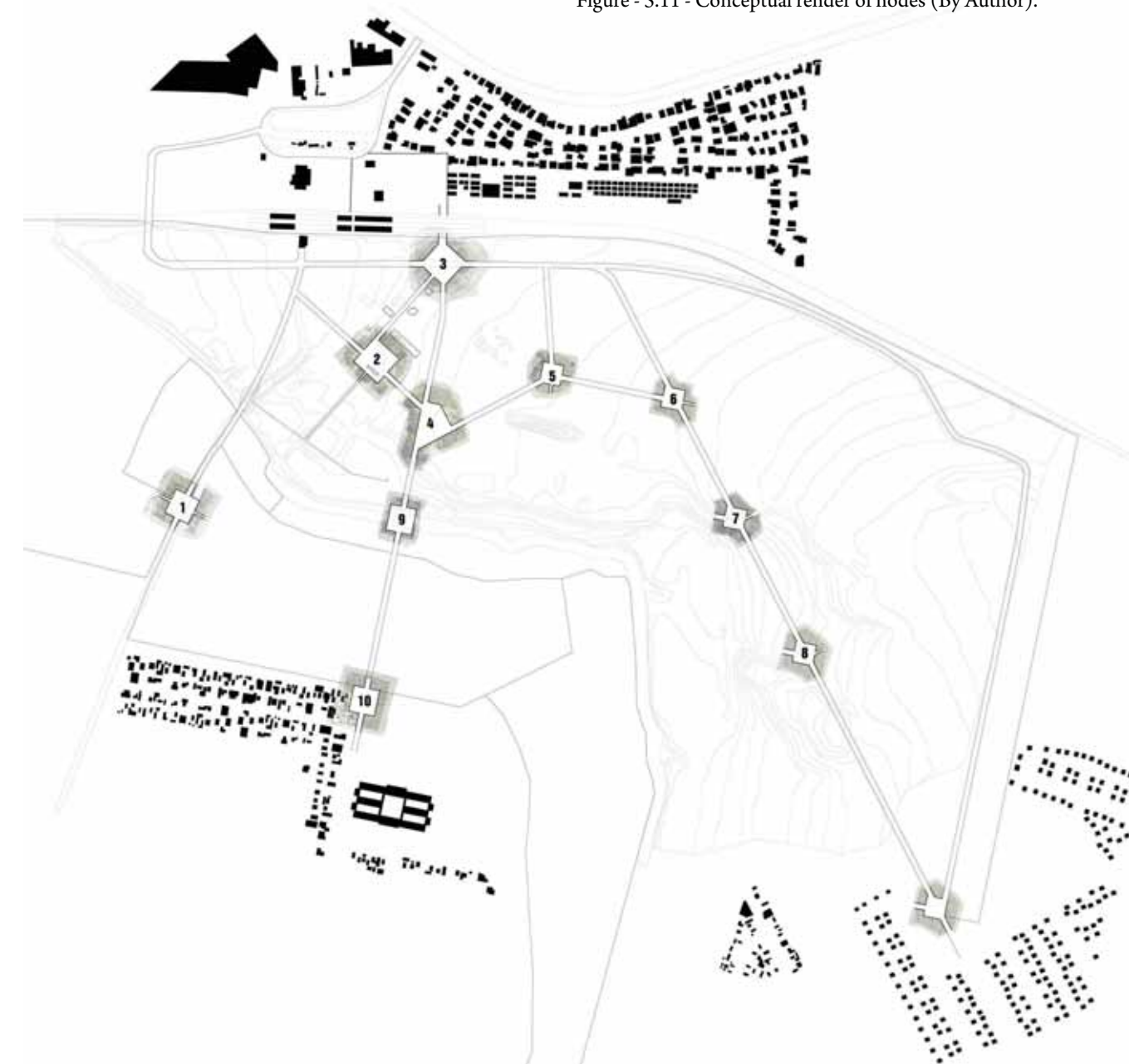

Figure - 5.12 - Nodes placed strategically across site. Nodes determined by the historical development of the site (By Author).

PART 2: ACTIVATION

The second part of the urban framework strategy is to activate these nodes and initiate development to and from nodes along the designated activity spines and corridors. The abattoir is a wasteful process and the opportunity therefore arises to recycle directly from the offshoot waste products from the abattoir.

The strategy employed is to introduce a series of Small Business Incubators (SBI's), which in some instances produce from the waste of the abattoir and in other instances provide a platform for local small businesses to achieve a foothold for development where after they can move out to provide space for new small businesses.

The model is based on the Business Incubation Centre in Pramtal, Austria by Spittelwiese Architekten. This centre was the product of 13 municipalities working together to provide a platform for small start-ups and businesses. The incubator consists of two volumes made up of a flexible production area in the back and an administrative volume at the front, with a service and communal amenities space in the middle. A centrally situated green atrium supplies the intermediate area with daylight and creates a focussed, yet bright working atmosphere for the young entrepreneurs. The low construction costs were made possible through the centre's consistent modular design and lack of basement space.

The low construction cost made it possible for very low letting rates for the start-up businesses, which add to the overall success of the concept and the final building.



Figure - 5.13 - Business Incubation Centre in Pramtal, Austria by Spittelwiese Architekten.



Figure - 5.14 - Plan of Business Incubation Centre in Pramtal, Austria by Spittelwiese Architekten.

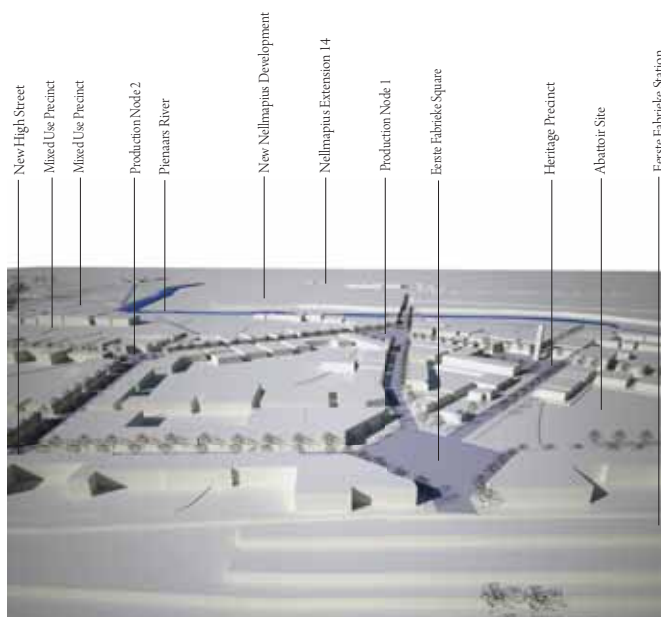

Figure - 5.15 - View to the south from the Eerste Fabriek Station (By Author).

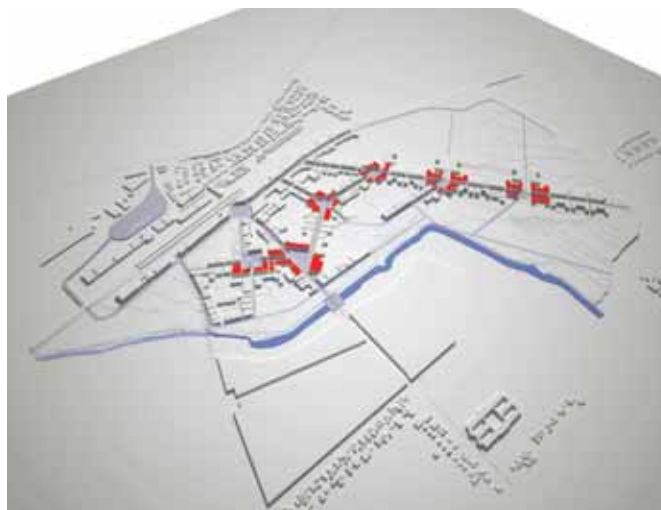

Figure - 5.16 - Small Business Incubators placed on the nodes to initiate development (By Author).

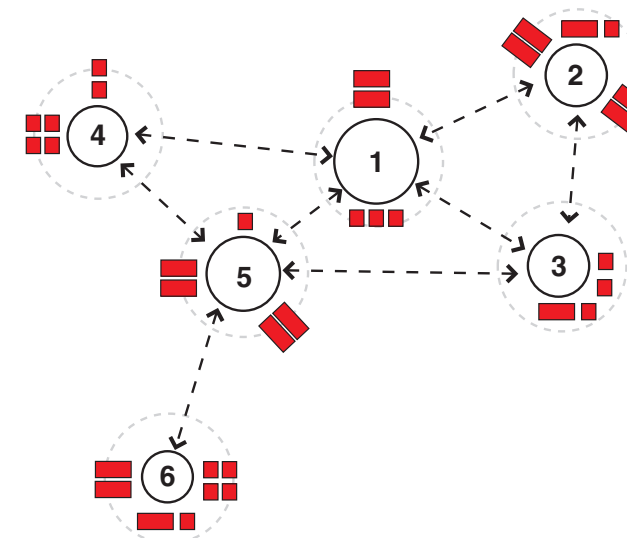

Figure - 5.17 - Concept - Activation

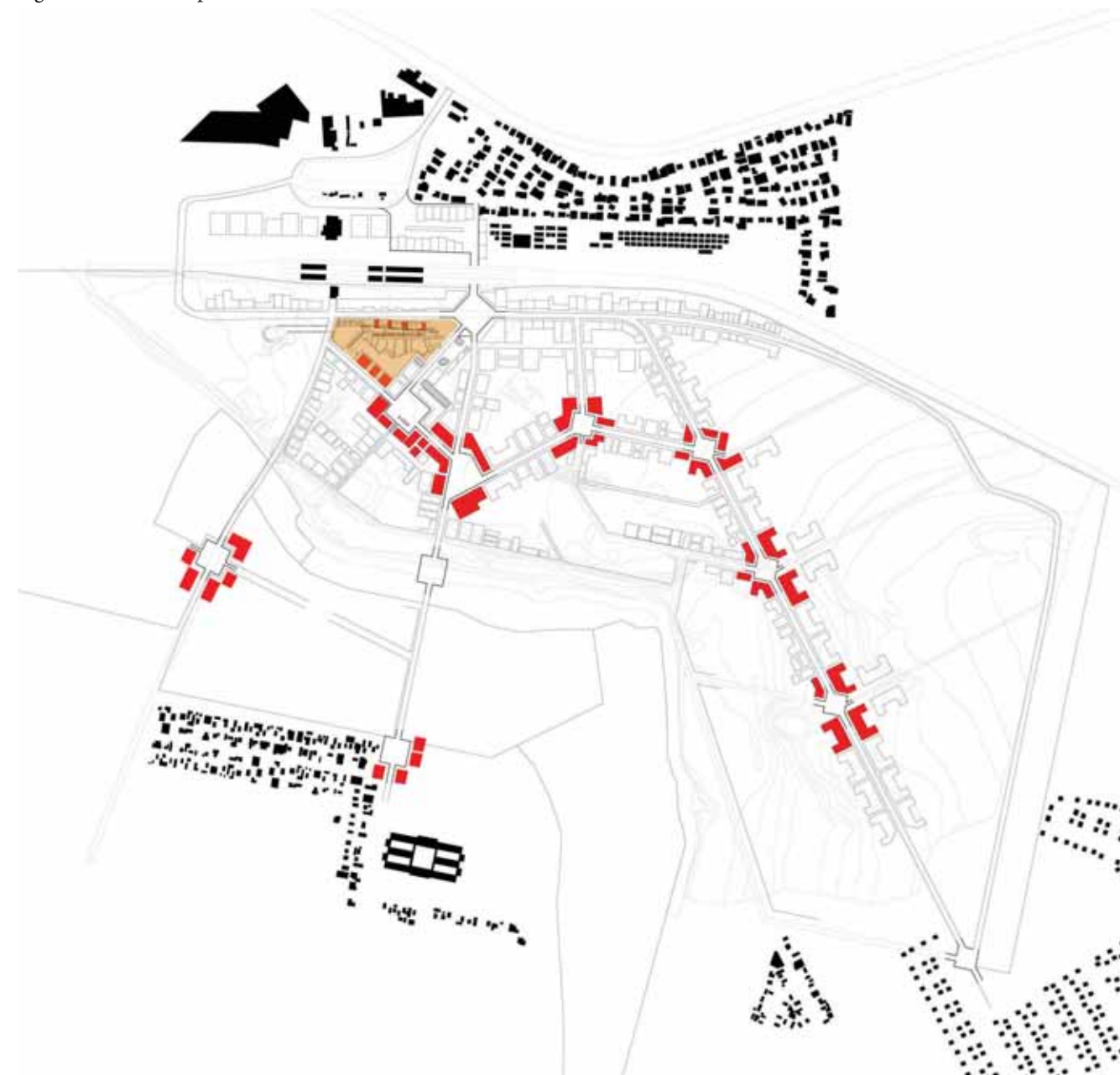

Figure - 5.18 - The Small Business Incubators indicated in red (By Author). Site indicated in orange.

PART 3: INVASION

The third and final part of the framework is the development around the nodes. If the nodes are to become successful, the areas between them will be filled with appropriate industry and commerce.

The central nodes (2-5) will be mainly focussed on industry and production to aid in the creation of a local economy for the Mamelodi and Nellmapius areas. Nodes 6-10 are proposed mixed use areas of commerce, high and medium density residential areas.

Nodes 2 and 3 define the public realm with the high street and heritage square which aims to attract commuters, pedestrians and foreign investment. Nodes 3-4 set up the connecting axis to Nellmapius which will be defined by wide sidewalks to accommodate the pedestrian movement to and from the Eerste Fabrieke Station to Nellmapius and its environs.

When fully developed, the framework represents a production node with a high degree of public engagement through ample commerce, heritage and residential function. The site now becomes a destination and a node in itself, connecting Mamelodi and Nellmapius where it previously acted as a barrier. The framework aims to help establish a local economy for the area by helping small start - ups and businesses through SBI's. The abattoir provides opportunity for production from its waste like hide processing, gut processing and other extremity processing that can be converted into a myriad of products.

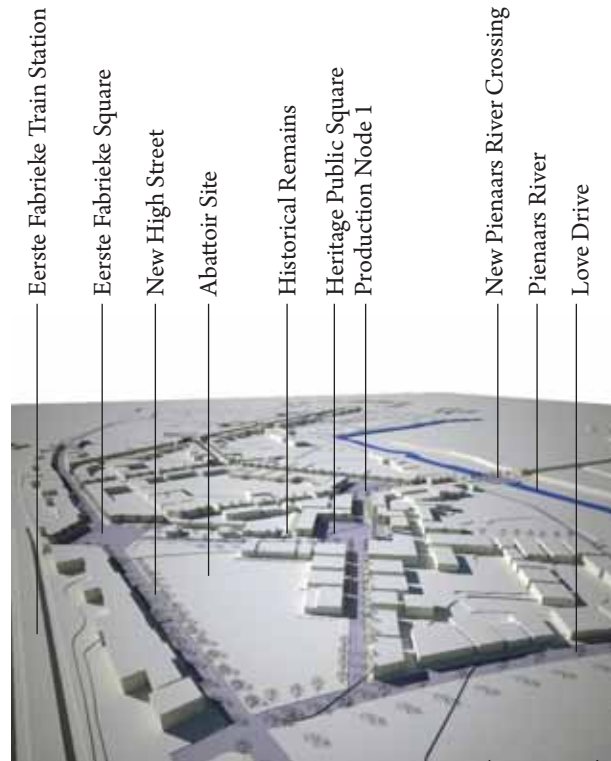

Figure - 5.19 - View across development looking east (By Author).

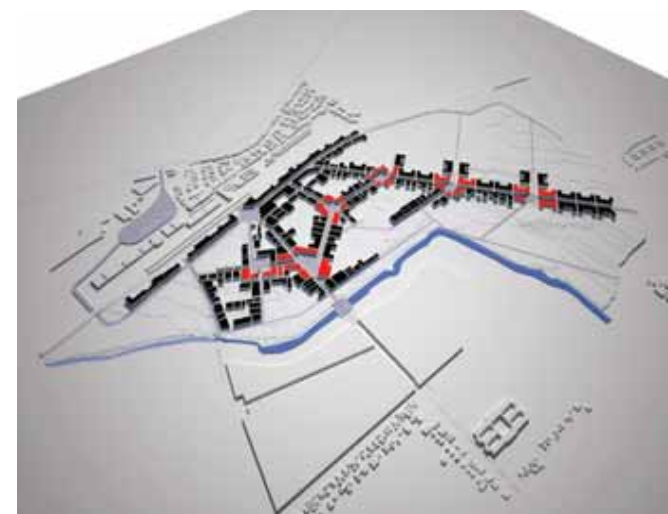

Figure - 5.20 - Further development initiated by the Small Business incubators (By Author).

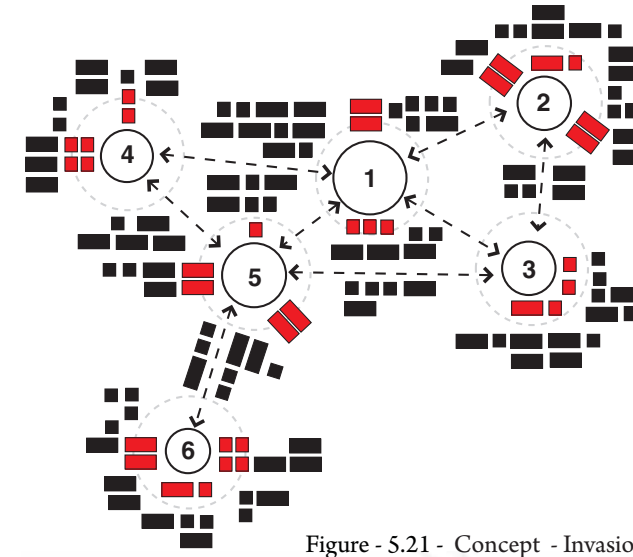

Figure - 5.21 - Concept - Invasion (By Author).

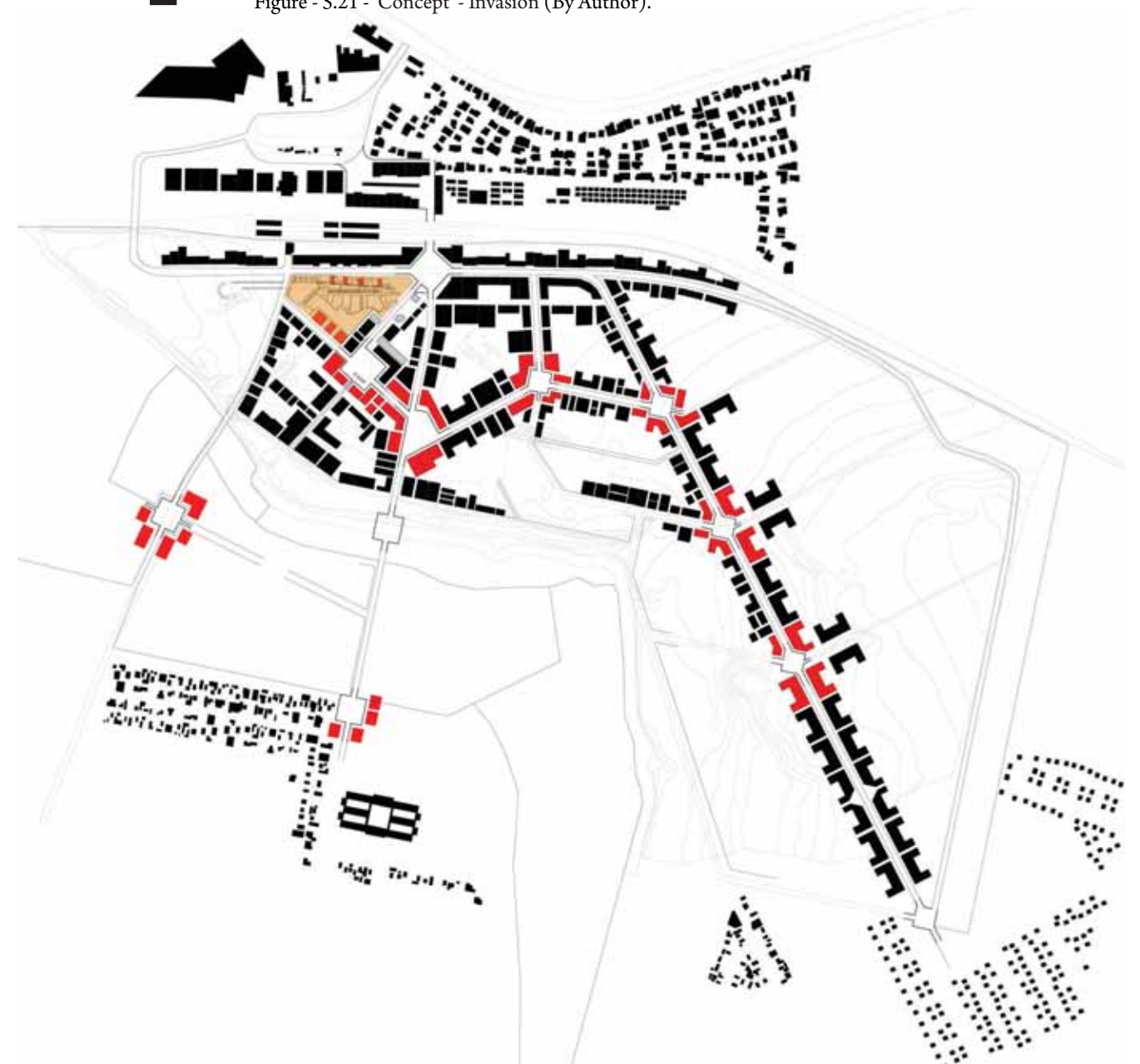

Figure - 5.22 - Further development indicated in black (By Author). Site indicated in orange.

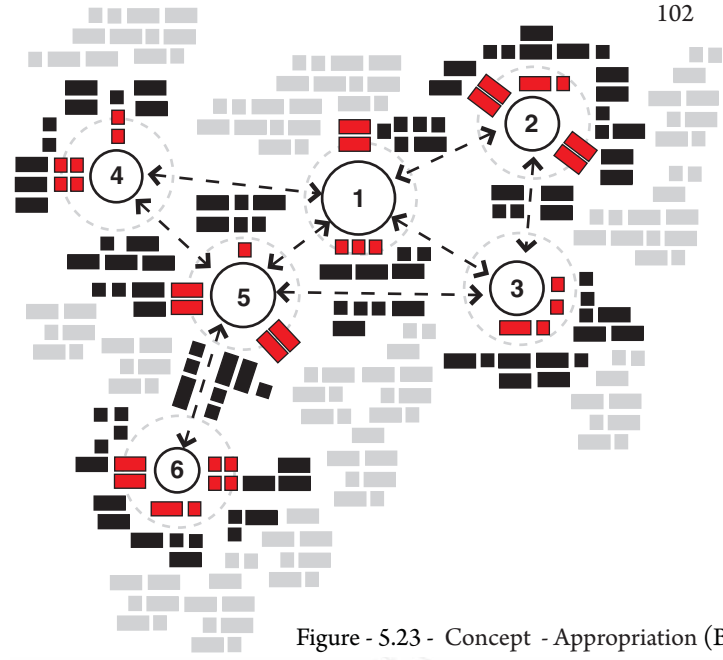

Figure - 5.23 - Concept - Appropriation (By Author).



Figure - 5.24 - Further development between nodes as area becomes appropriated (By Author).
Site indicated in orange.



Figure - 5.25 - Final Conceptual render of development indicating the invasion level of development (By Author).

ZONING

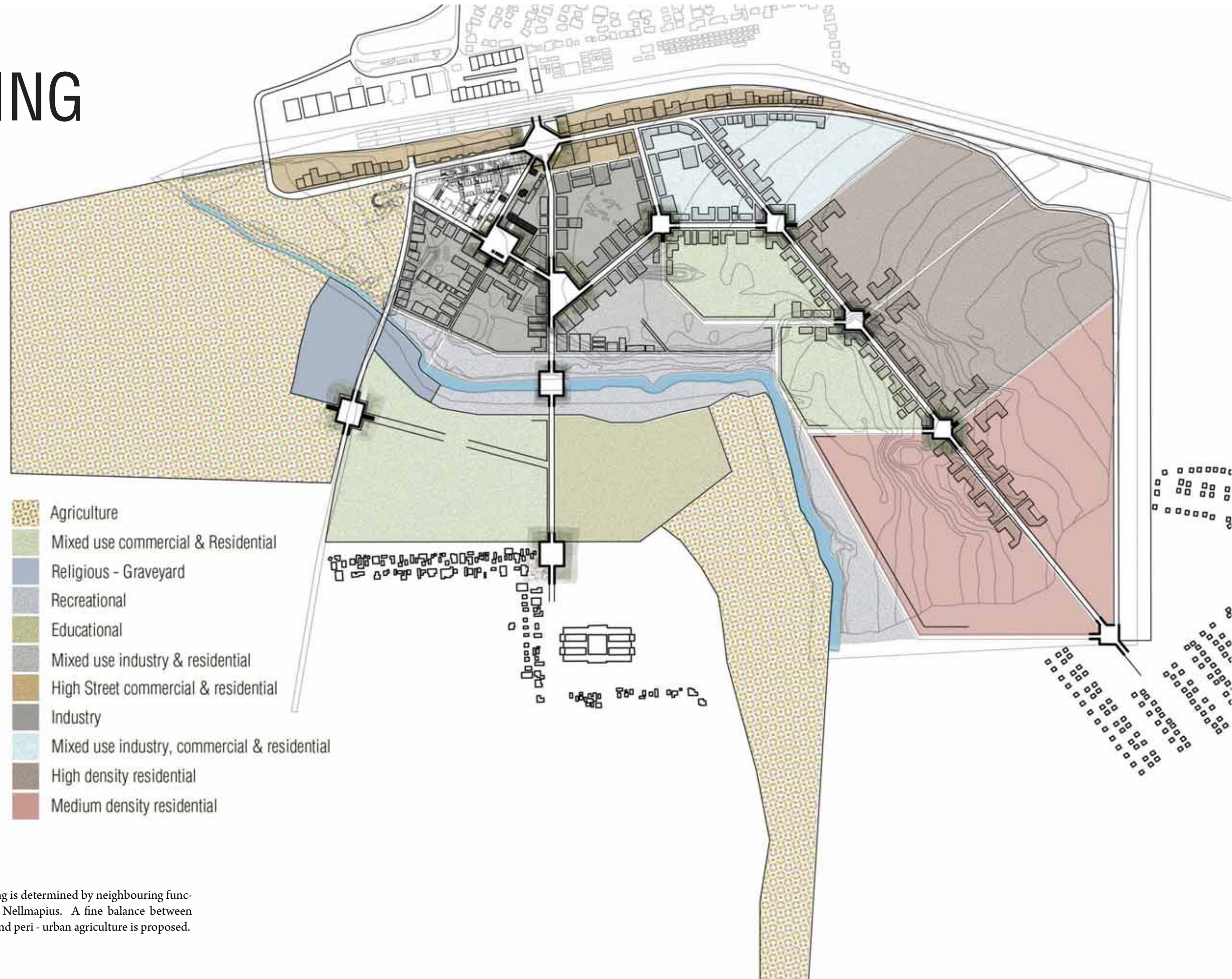

Figure - 5.26 - The zoning is determined by neighbouring functions of Mamelodi and Nellmapius. A fine balance between light industry, housing and peri - urban agriculture is proposed.

ROUTES

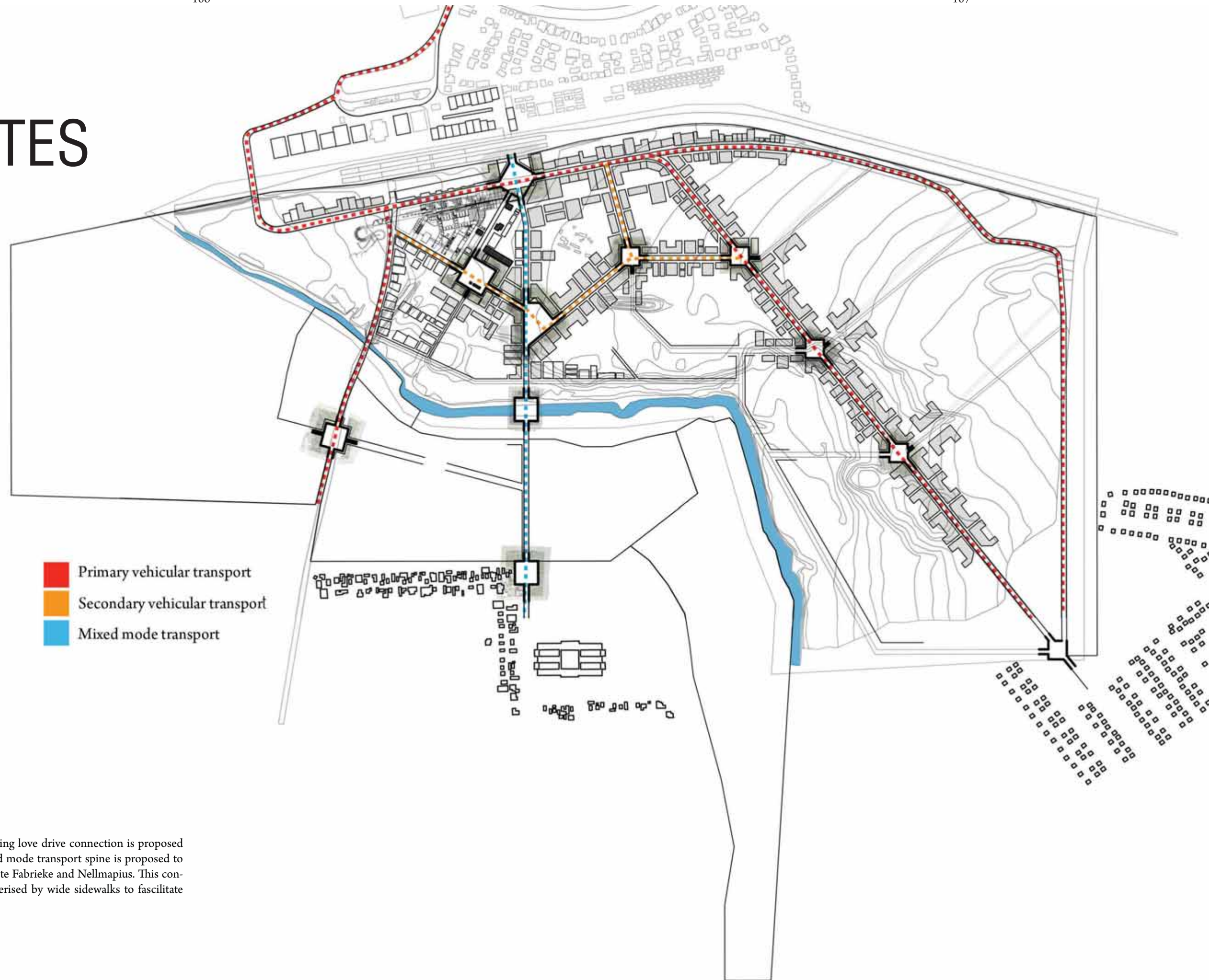

Figure - 5.27 - The existing love drive connection is proposed to be upgraded. A mixed mode transport spine is proposed to connect Mamelodi, Eerste Fabrieke and Nellmapius. This connection is to be characterised by wide sidewalks to facilitate pedestrians and cyclists.

SITE

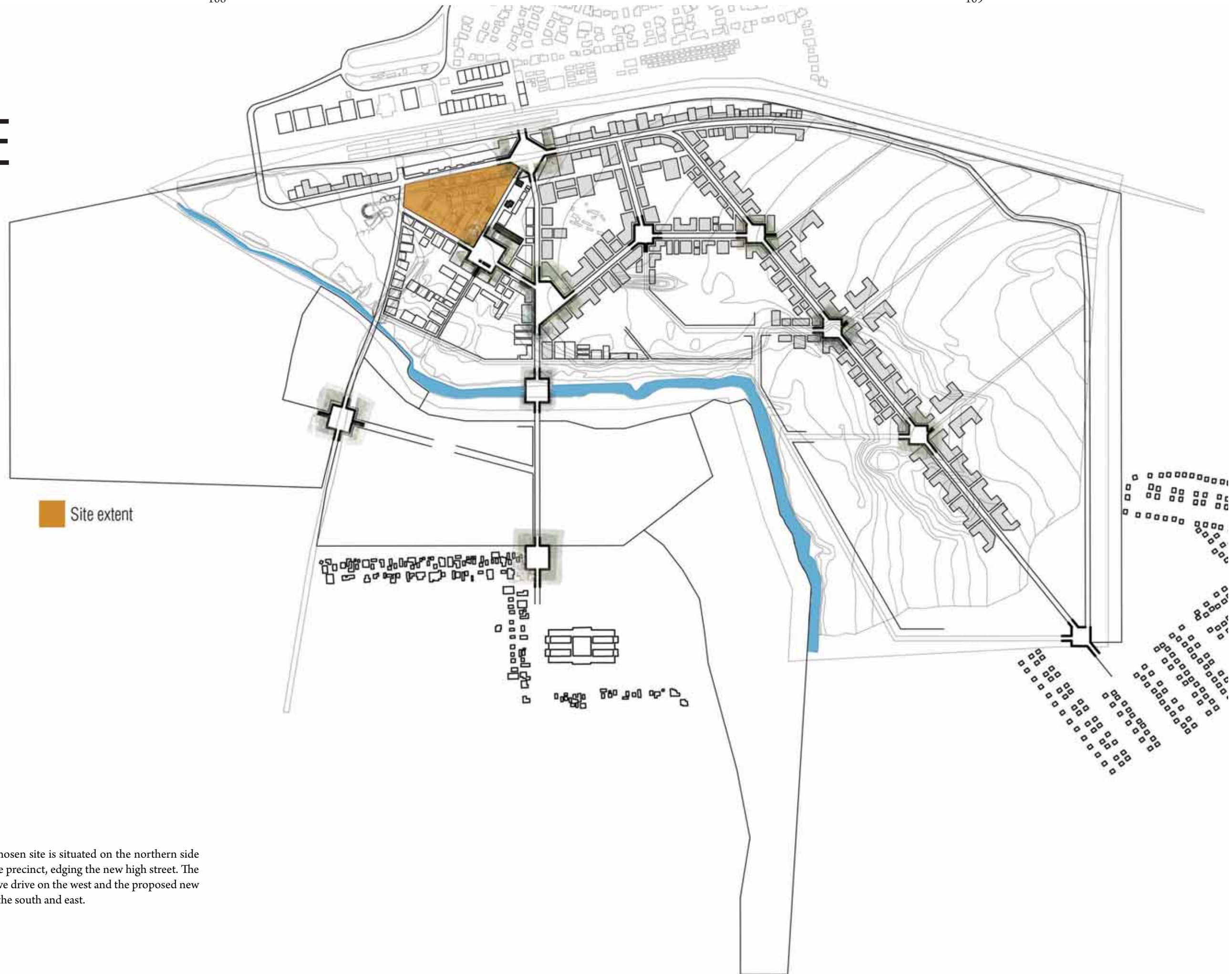

Figure - 5.28 - The chosen site is situated on the northern side of the Eerste Fabrieke precinct, edging the new high street. The site is bordered by Love Drive on the west and the proposed new heritage precinct on the south and east.

Figure - 5.29 - Rendered perspective view looking east from the site. The production nodes beyond the site become clear as it forms a productive network. The heritage square to the south, the Eerste Fabrieke square to the north (creating the entrance to the site) and the high street running east to west across the site can be seen.



Figure - 5.30 - Rendered perspective view looking north up through the mixed modal circulation spine. This corridor is characterised by wide pavements to accommodate pedestrians and cyclists. The corridor also acts as the linking mechanism between Nellmapius, Eerste Fabrieke and Mamelodi.

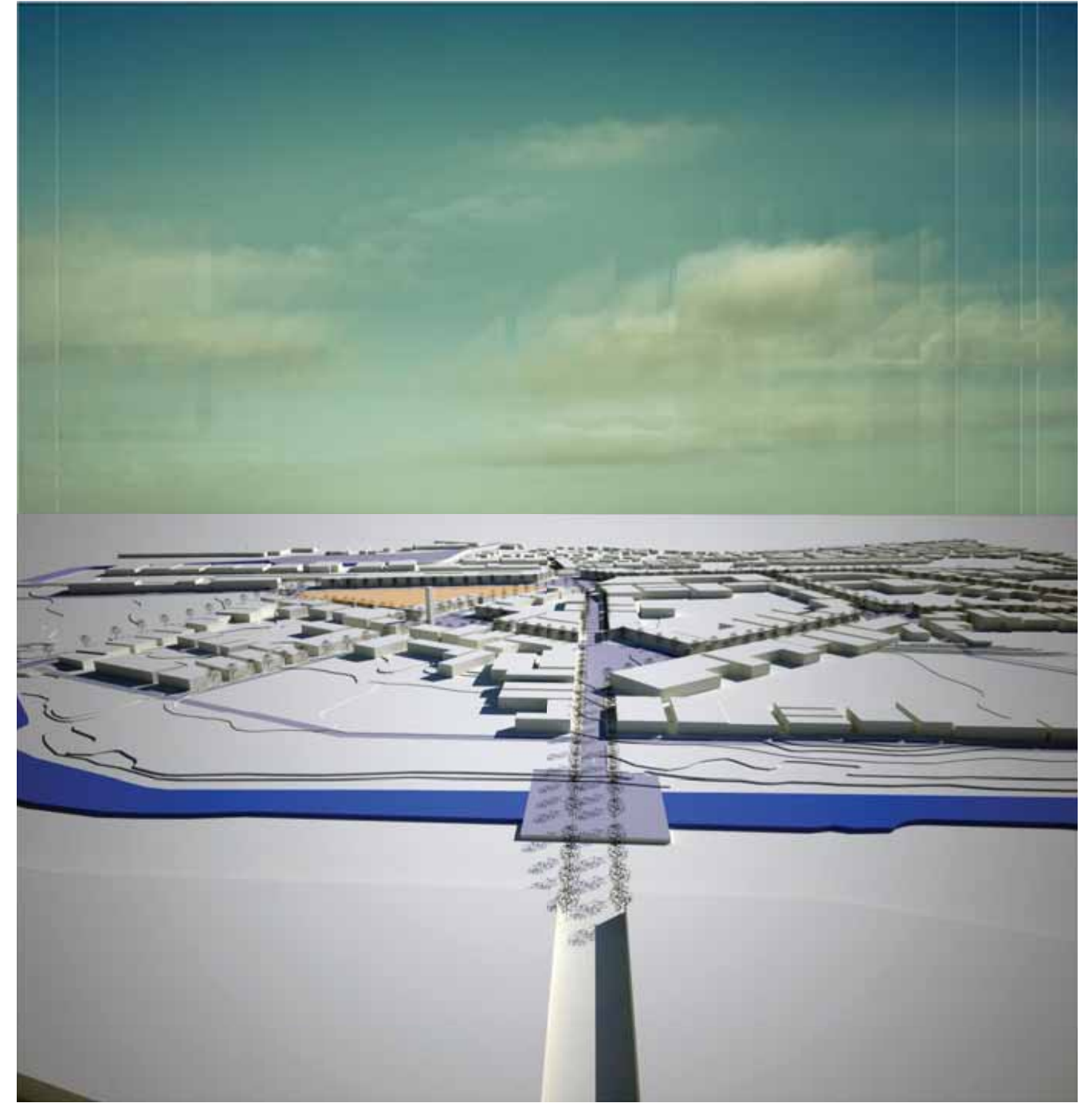

Figure - 5.31 - Rendered perspective view looking east from the mixed use housing and light industry area. The node at the bottom of the image is where the development transitions from that of a productive area to a more medium density housing development.



Figure - 5.32 - Rendered perspective view looking south down towards Nellmapius extension 3. This activity corridor acts as the connecting mechanism between the Eerste Fabrieke development and the residential area of Nellmapius. The left side of the corridor will be characterised by medium to high density housing and the right side by mixed use industry and medium density residential.



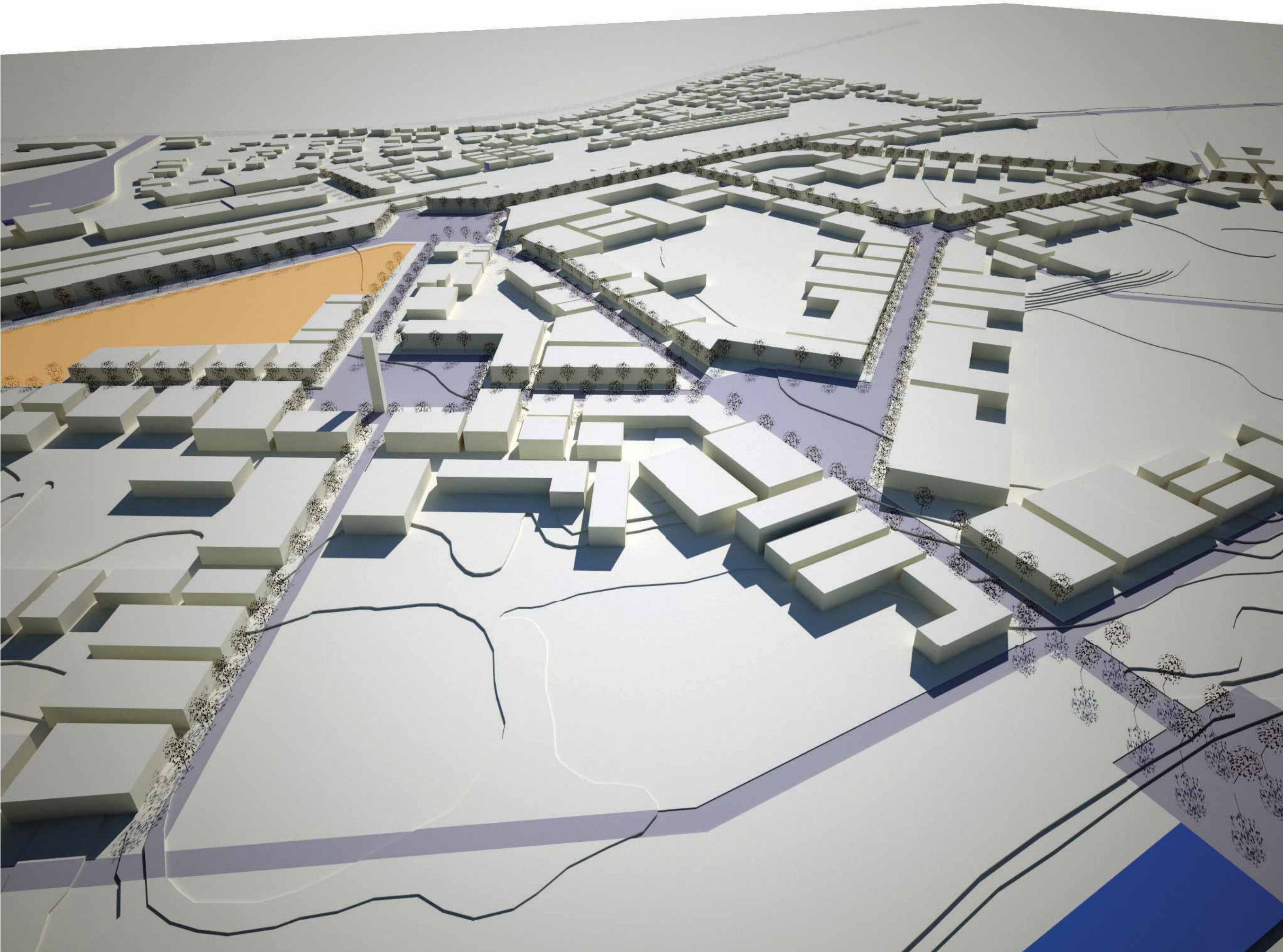

Figure - 5.33 - Rendered perspective view of the heart of the development around the heritage square. String and bead like nodes connect the otherwise unstructured site based on the historical events of the site. The dislocated Nellmapius area is now connected to Mamelodi through the new development on the Eerste Fabrieke precinct.

PRECEDENT STUDIES

PREMISE

The precedent studies to follow were done based on the four matrices of architecture namely form, function, context and technology. The investigation sought insight not only into programme but inspiration from the entire architectural spectrum.

Figure - 6.1 - Photograph of a abattoir worker leading a carcass down to the inspection area (By Author).



FORM ONE

Seabird Island School, Agassiz, British Columbia, 1988 - 1991, Patkau Architects

This project was chosen as a formal precedent due to its unique tectonic quality. The project was designed for the aboriginal community of the area who strongly influenced the educational program and at the end also the building form. The school is situated in a river valley on a large open field with mountains towering around it.

Design: The school is not exclusive to students but also facilitates lectures which the entire community can attend. Each classroom is accessible from the common outside area which is populated with community buildings and this encourages interaction between the school and other community amenities.

The heavy timber post and beam structural system used, conforms to the traditional Salish building heritage. The structural system constantly changes to adapt to edge conditions and requirements. The northern edge consists of large sculptural closed volumes to shelter the occupants from the harsh winter winds. The southern end of the building is much smaller in scale, but much more open under the large eaves of the roof.

A similar expressive roof structure is envisaged for the abattoir, as this element is to make connections and act as the heart of the abattoir which will contain the majority of the systems.

The planning of the Seabird School also informed the design of the abattoir. The building is orientated along a southern facing porch which stretches the length of the building and allows for the direct accessibility of the classrooms (refer to Fig no.) On the southern side of the porch six teaching gardens create a public teaching interface with the other community buildings.

The organisation of functions around a linear circulation element, which separates public and semi public spaces, informed the treatment of the high street facade with which the abattoir needs to interact. Not only the planning but also the three di-

mensional quality of the building needs to interact and adopt an attitude towards this condition.

The materiality of the Seabird school was designed to weather with time. The timber would become dull due to sun exposure, as do the shingles which will change colour depending on which side of the building it is on.

The abattoir will have to be more hard wearing than this design, but the real challenge lies in maintaining the intricate tectonic quality of the structure.



Figure - 6.2 - The heavy engineered timber post and beam construction.

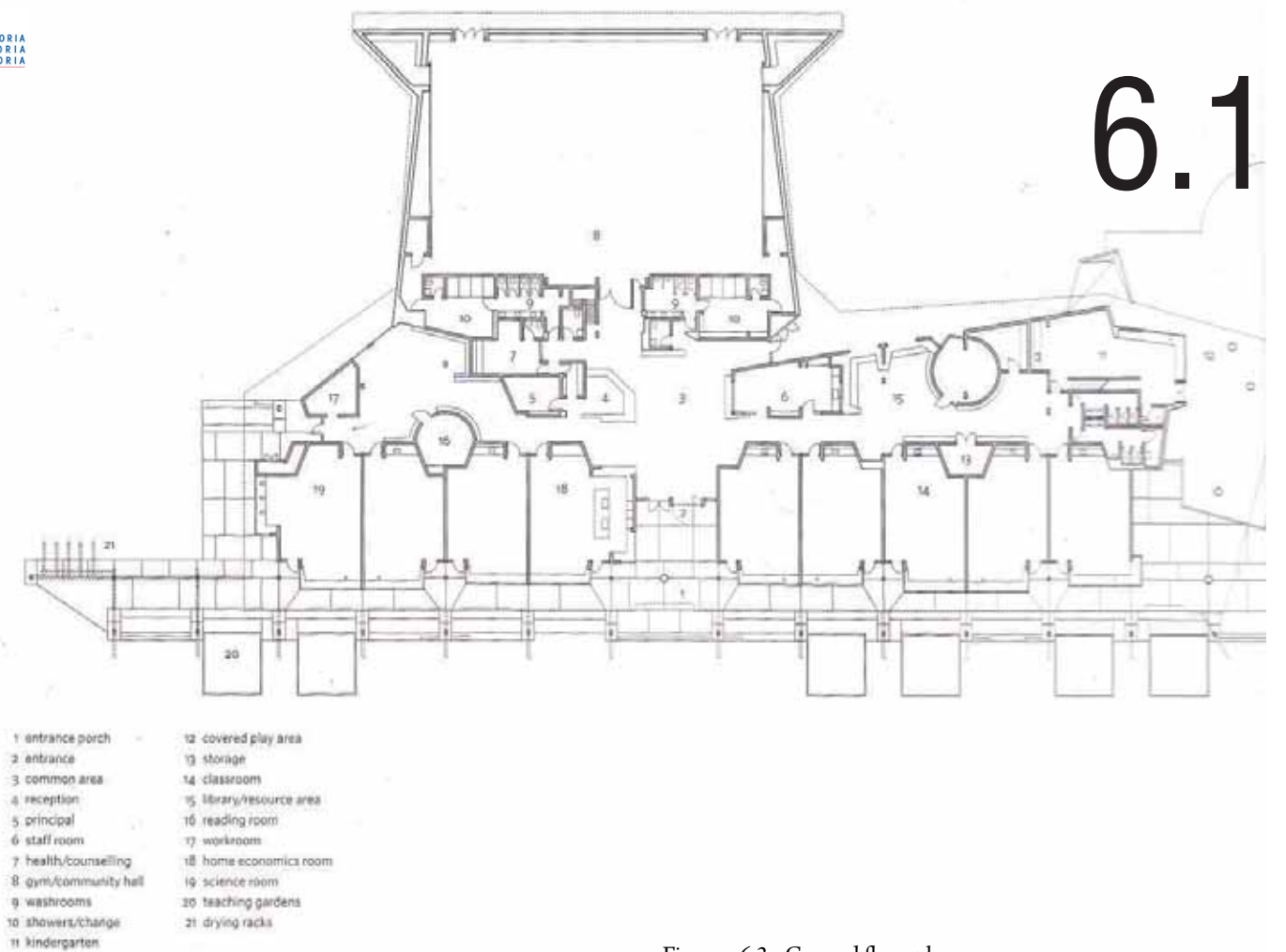

Figure - 6.3 - Ground floor plan.



Figure - 6.4 - The building is organised around the porch with the bulk of the building situated on the northern side and connections to other community activities to the south.

6.1



Figure - 6.5 (Above) - The heavily engineered structure was too complicated for the local builders to understand, so the architects built a exact physical model to explain the three dimensional characteristics of the tectonic roof structure. The model also depicts the changing nature of the roof structure and the different approaches to the opposite ends of the building.



Figure - 6.6 (Right) - This image shows the intricate nature of the roof design. The roof constantly changes to allow access into the building, gathering space and shelter and to establish thresholds. The roof acts more like a mechanism, organising movement around and underneath it.

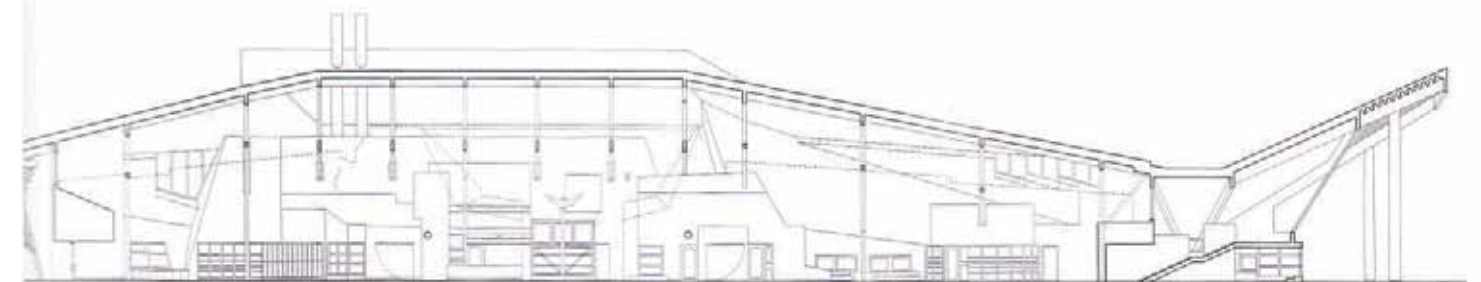

Figure - 6.7 - Sections indication the changing nature of the roof structure.

FORM TWO

Landscape Formation One, Weil am Rhein, Gemany, 1996 - 1999, Zaha Hadid

This second formal precedent was chosen due to the way in which the design integrates itself into the surrounding landscape. Landscape Formation One was designed for the 1999 horticulture show in Weil am Rhein. The project forms part of a series of architectural projects eliciting new spatialities from natural landscapes.

"In contrast to conventional urban and architectural spaces, natural landscapes typically contain a multitude of subtly differentiated territorial definitions and smooth spatial transitions. In the context of traditional architectural principles and practice, these features might be considered to lack order and clarity. We disagree with this point of view - believing that they liberate a more complex and nuanced way of ordering spaces."

Zaha Hadid (1999)

Design: The design is conceived as a series of paths which integrates itself into the surrounding gardens. The building is characterised by its horizontality and its alien shape, which blends into the landscape remarkably well.

The building appears to grow from the ground with low concrete walls defining the paths that can be taken over and through the building. These paths trap four spaces between them, forming pavilion like structures. These pavilions house offices, exhibition spaces and a restaurant. The building is orientated in such a manner to maximise the natural conditions in summer and winter and also uses the submerged nature of the design to aid environmental concerns.

This method of organisation assists the abattoir design in the organisation of the entire site. The site is extremely big and contains remnants of previous industrial buildings buried un-

derneath the surface. By adopting a form which grows from the ground, connections can be made to the heritage and the new industry on site. Planted or green roofs can aid in the insulation required for the cool spaces in an abattoir and can counteract the heat island effect. Spaces trapped between connections can be explored as communal green spaces in the abattoir, humanising the monotonous place of production.

In Landscape Formation One, paths extend across the building, the abattoir would rather focus on extending the natural landscape as the abattoir is informed by its immediate surroundings.

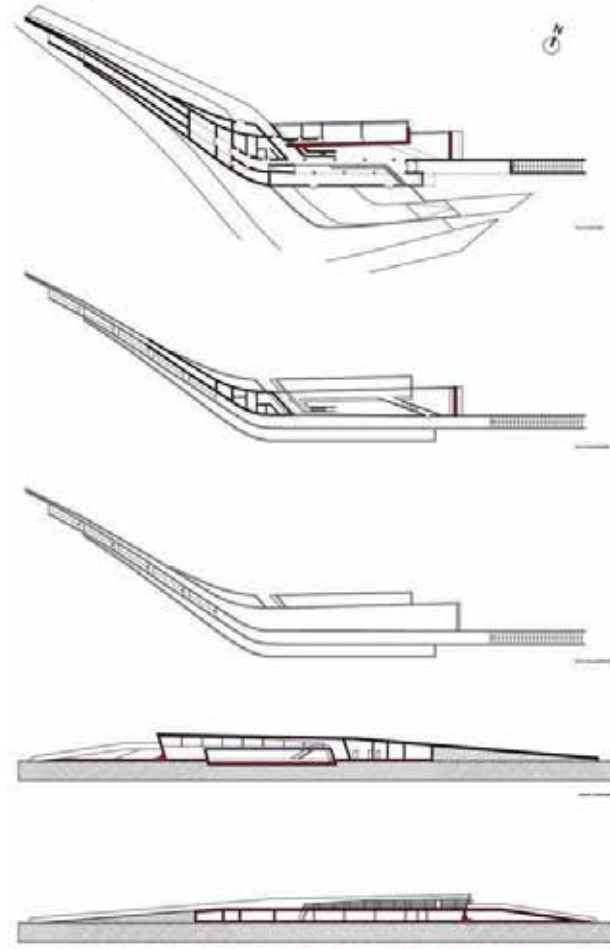

Figure - 6.8 (Right) - Plans and sections indicating how the building integrates into the natural landscape.

6.2

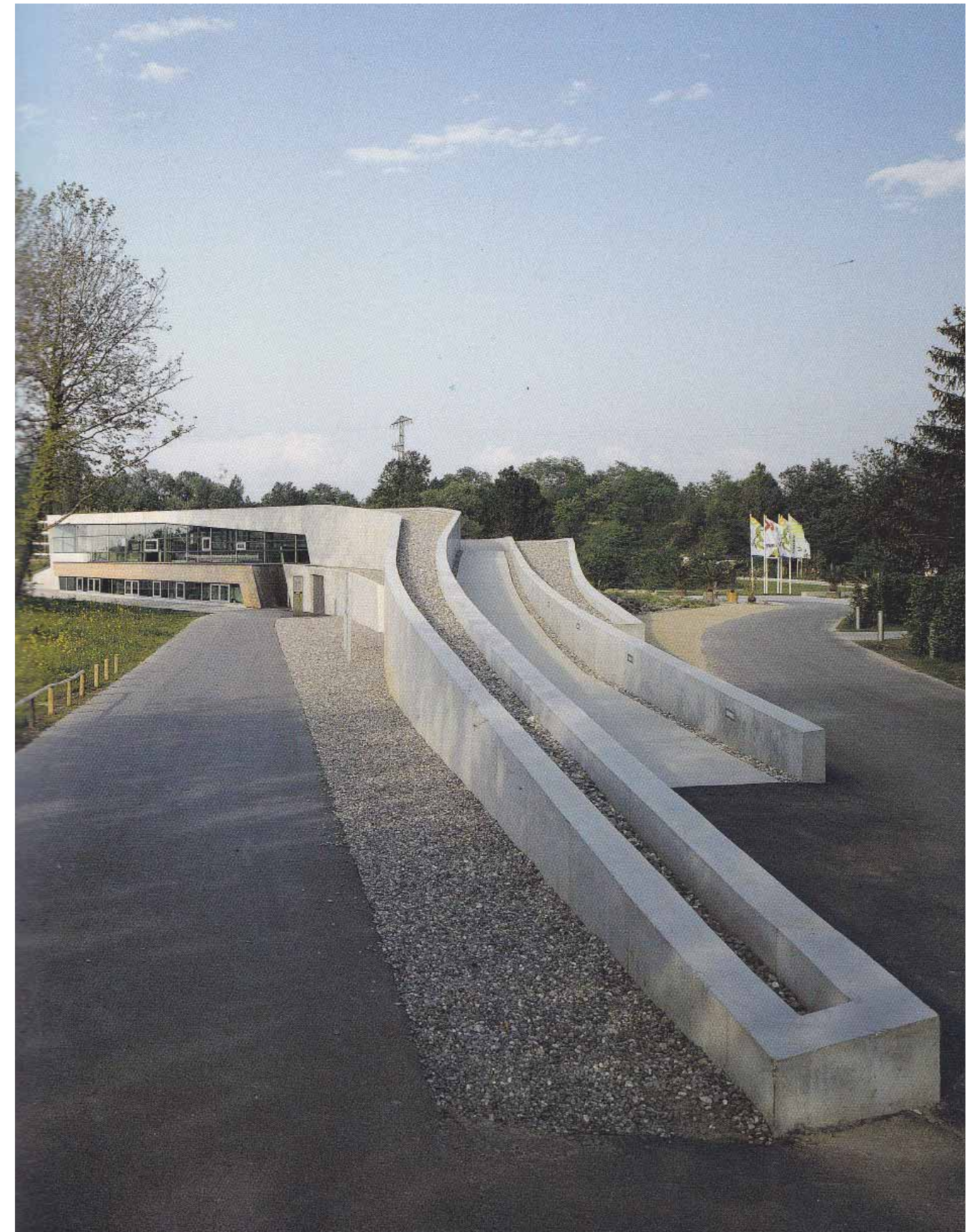

Figure - 6.9 - A path grows into a building and back into a path again.

FUNCTION ONE

Abattoir in Horsens, DENMARK, 2000 - 2004, Arkitema K/S - Jorgen Bach:

The Horsens pig abattoir is a place where 10 million pigs are slaughtered every year. When architect Jørgen Bach was asked to design the abattoir, he was faced with a moral dilemma. Did he want to be responsible for a place where all these animals are going to be killed every year?

“Internally there were some long discussions about the contract — mostly about the killing part, of course, — and we ended up agreeing: The pigs will die at any rate, regardless of whether we design the building or someone else does it. So we should at least make sure that they are given decent treatment and employees have suitable working conditions”

Jørgen Bach 2007

Design: The abattoir in this case was conceived differently compared to the Yorkshire (discussed under the technology heading p. 134 - 135) abattoir. The Horsens abattoir focuses on working environment internally and the public image of the company externally. The exterior of the building has no remnants of the typical industrial abattoir typology. Instead, the 1km long building has a very contemporary feel to it with its colourful cladding and large glazed areas. The architect believes that by investing in the architectural aesthetic and not conforming to the typical industrial typology, stigmas of the abattoir can be overcome, aiding the company in its marketing and public image.

The abattoir was designed for a company called Danish Crown and is one of the most high tech abattoirs in the world. The process is largely industrialised and processes such as deboning, evisceration and cutting are done by robots. It took 100 engineering specialists from around the world to aid the design. These technologies result in a place of immaculate hygiene and performance. Although such systems will not be employed in the design of the abattoir, other, more common, systems used



Figure - 6.10 - A completely different aesthetic was used compared to the typical industrial sheds.

in harmonising the working environment and providing more comfortable conditions for animals were discovered.

One such system is the CO² stunning method introduced in the design. It consists of a platform onto which the animal is led, the platform then lowers into an underground chamber saturated with CO² which gently puts the animal to sleep before the main artery is slit to bleed the animal. This avoids the stunning process which in many cases does not sufficiently render the animal unconscious prior to slitting (witnessed at the Rietvlei abattoir visit). It also prevents the penetration of the animal's skull.

Courtyards, as seen in Fig 6.11 are introduced between production spaces, to allow for views from inside the building and also recreational activities.

Danish Crown pig abattoir represents a new typology model in the design of industrial buildings and processes. By not conforming to the architecture of economy standard and exploring the architectural possibilities within the process, such buildings can become more attractive to the public realm and could be introduced into the urban network.

6.3



Figure - 6.11 - Courtyards are introduced between administrative and production spaces, as depicted in this image. These spaces allow workers to step outside whenever the monotony of mass production becomes too much. The courtyards also allow natural light to penetrate the building and create views from within the building.



Figure - 6.12 - An image from the Danish Crown website depicting the automation of the processing of the pigs.

FUNCTION TWO

Rietvlei Meat Products Abattoir, Benoni, South Africa, 2004, Birmeister Van Niekerk Consulting Engineers:

To further understand the operations, systems and general function of the abattoir, a visit to the Rietvlei Abattoir in Benoni was made. The visit was done with the guidance of operational manager Robbie Hamilton. He allowed full access to the abattoir operations where the process could be witnessed.

Rietvlei Abattoir is a medium sized abattoir and slaughters up to 150 cattle and 500 pigs per day. Livestock is purchased directly from feedlots around Gauteng Province and they produce a myriad of products from the abattoir. They specialise in canned meat and prime cut meat products.

Design: The abattoir was not designed by an architect, which is evident on arrival and when looking at the plan (Fig 6.16). The building was designed by an engineering firm and is executed in a very engineered manner.

Layout: The abattoir consists of a main building, which houses the slaughtering and processing functions, and a series of smaller outbuildings scattered across the site. Outbuildings serve as offices and basic amenities for staff.

The main building is strictly designed around a process and once the slaughtering starts, around 06:00 am, the building becomes almost inaccessible. Carcasses suspended from the roof stops any circulation within the abattoir during the slaughter process, ducking, diving and squeezing was required to move beyond certain points.

One thing became very apparent during the visit, and that is the separation of the three basic planes of architecture, namely: wall, floor and roof plane. These three elements all become functional within the abattoir, and no wall, floor or part of the roof is not utilised. The roof acts as the system, it carries the animals, pro-

vides light, provides ventilation and contains numerous systems hidden in its engineered structure. The wall becomes the working space. Lightweight platforms are suspended from the walls which are occupied by the workers. The animals move alongside these platforms whilst suspended from the roof and are



Figure - 6.13 - A wall of carcasses meets you on entry. (By Author)

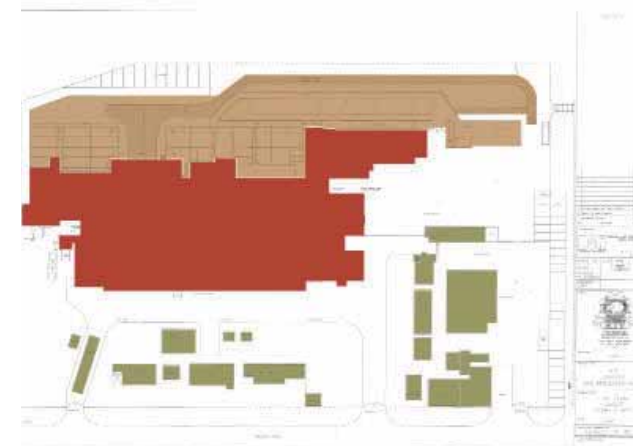

Figure - 6.14 - The massing of the site. Administrative functions are scattered across the site (By Author).



Figure - 6.15 - A large amount of circulation space which is unused (By Author).

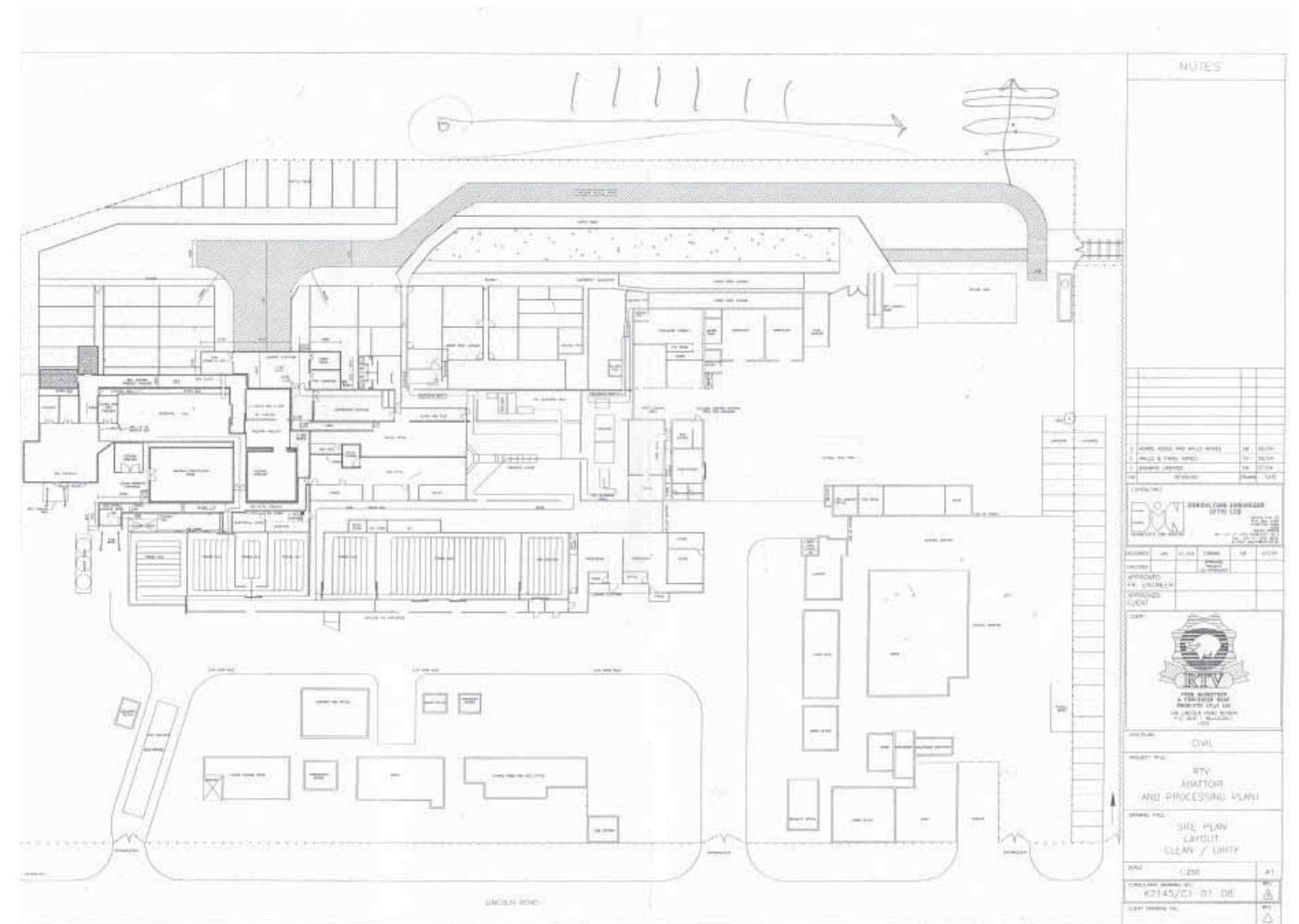

Figure - 6.16 - Rietvlei Abattoir Plan.



Figure - 6.17 - The cattle is hooked and hoisted after it has been stunned (By Author).

then processed. Lastly, the floor acts as a canvas for the capture and flow of water, viscera and blood. As shown in Fig 6.18, the floor is clear of workers and is constantly covered in water and other organic matter. The abattoir is designed in a compact manner and the process snakes through the building. This layout is partly responsible for the inaccessibility of the space. The space becomes extremely cluttered, with different processes happening in extreme proximity to each other. Extreme care has to be taken so that no cross contamination takes place.

After the slaughtering process the carcass has to move along rails suspended from the roof for almost 50 meters to the inspection area. The meat is graded and moved off to an isolated chilling area. Between the slaughter, chilling and processing areas there is no separate circulation for employees. They have to follow the path of the carcass. Once again, this can result in contamination.

The deboning and boxing halls are situated on the western side of the building and are surrounded by chiller rooms which form the edge or envelope of the structure. These chiller rooms open directly onto the dispatch area.

Consumption:

During an interview with Mr. Robbie Hamilton (operations manager) on 20/07/2011, the general consumption figures of the Rietvlei Meat Market were discussed and are as follows:

Water consumption - On average, total water consumption of 200 000 litres per day. 400 - 1000 litres of water per head of cattle slaughtered.

No water recycling systems are in place and all drains are connected to a municipal sewer.

Electricity - The exact amount of electricity was not divulged, but is quoted to be "extremely high". The abattoir operates for nine hours daily and uses a coal fired boiler to heat water for the scalding of the pigs. This results in high amounts of air pollution, which is immediately smelled upon entering the site, but in turn lowers the electricity consumption.

The abattoir does not employ any solar or other energy generation systems and makes use of municipal electrical supply only.

Recycling - Rietvlei recycles every part of the animal and sells it to a wide variety of manufactures. All the blood from the bleeding pit is drained into tanks and used for composting on Mr. Hamilton's personal farm.



Figure - 6.18 (Above) - A row of carcasses hangs as the man skins them (By Author)

Figure - 6.19 (Below) - The Roof structure with all its rails and systems (By Author).

This precedent outlined the general problems with abattoirs in South Africa. Opportunities to generate large amounts of energy from the processes housed in the abattoir, such as heat recovery systems, water recycling systems, water treatment systems, etc., are not even considered in the design of such places.

The abattoir as place has no consideration for the worker spending 9 hours, five days a week inside its walls. The place contains no recreational spaces or views outward from within the building, emphasizing the macabre nature of the process. This abattoir makes no use of air recycling or extraction systems to purge the smell within the space, resulting in even worse working conditions.

Furthermore, this abattoir justifies its geographical location on the periphery of the city, as it is a wasteful (water and power) and dirty place, even though it conforms to the standards set out by the Department of Agriculture and the Red Meat Association of South Africa. Local abattoirs, like many other industries, just conform to the minimum standard that seems to be insufficient at best.

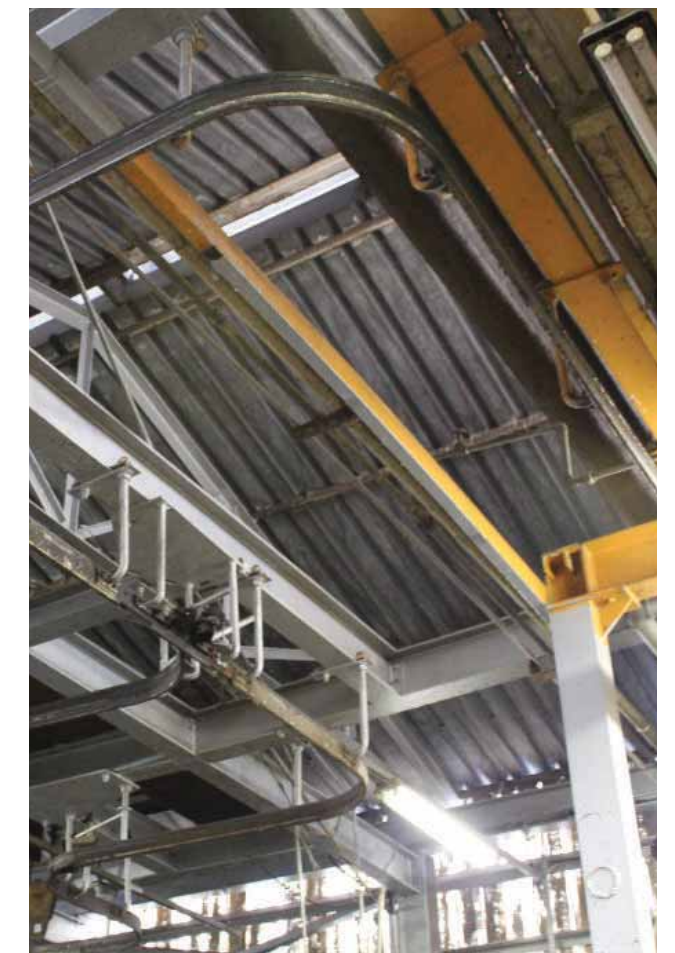

CONTEXT

Quai Branly Museum, Paris, France, 1995 - 2006, Ateliers Jean Nouvel

Jean Nouvel's Quai Branly Museum was chosen as a contextual precedent because of the way it interacts with the existing heritage on site in Paris. The museum was designed around a specific collection of primitive art, to as an auxiliary exhibition to that of the Louvre.

"Its architecture must challenge our current Western creative expressions. Away, then, with the structures, mechanical systems, with curtain walls, with emergency staircases, parapets, false ceilings, projectors, pedestals, showcases. If their functions must be retained, they must disappear from our view and our consciousness, vanish before the sacred objects so we may enter into communion with them. This is, of course easy to say but difficult to achieve..."

Jean Nouvel (2006)

Design: The design is realised around a specific exhibition and the control of the environment around it. The exclusion of light and the inclusion of the single ray that enters, are controlled. The building, situated between historical Parisian buildings, is of a completely different aesthetic, but is physically anchored to the old buildings. As seen in Fig 6.21 & 6.26 the western side of the building is connected to an old building that contains the administrative programming of the design.

The new design grows from out of the existing structures as if it is a contemporary continuation of the old. Connections seem to be designed very boldly and is realised by large green glazed screens that connect to the roofs and the courtyards in between. These connections, which at first sight appear bold, are extremely effective and maintains a respectful relationship with the old. On the northern street facade a connection to the existing facade is made and similar rhythms are continued except for the new facade that is completely planted from top to bottom, as seen in fig 6.26

Auditoriums and other exhibition spaces are sunken beneath the ground so as not to negate the form of the above ground structure. Above these submerged spaces is an open park that was designed as a forest in which the exhibition is displayed.

"The resulting architecture has an unexpected character. Is it an archaic object? A regression? No, quite the contrary, for in order to obtain this result the most advanced techniques are used: windows are very large and very transparent, and often printed with huge photographs; tall randomly-placed pillars could be mistaken for trees or totems; the wooden sunscreens support photovoltaic cells. The means are unimportant- it is the results that count: what is solid seems to disappear, giving the impression that the museum is a simple façade-less shelter in the middle of a wood. When dematerialization encounters the expression of signs, it becomes selective; here illusion cradles the work of art."

Jean Nouvel (2006)

Jean Nouvel's approach to the design of the museum is the complete opposite to what the design of the abattoir entails. He hides systems and functional objects whilst the abattoir displays these objects as important organising elements in a designed process.

The precedent was not chosen for its approach to internal spaces, but for its very apparent attitude towards heritage. The building does not shy away from or ignore the heritage, but embraces the aesthetic differences and establishes a juxtaposition on site. The heritage does not get mothballed, instead it is incorporated as a functional part of the abattoir and denotes an important threshold in the design. This relationship, be it bold, creates a synergy, and one without the other would not be as successful.

The remnants on the site of the abattoir need to be incorporated into the design. Two underground bunkers in which whiskey was stored, are situated on the southern boundary of the site.

6.5

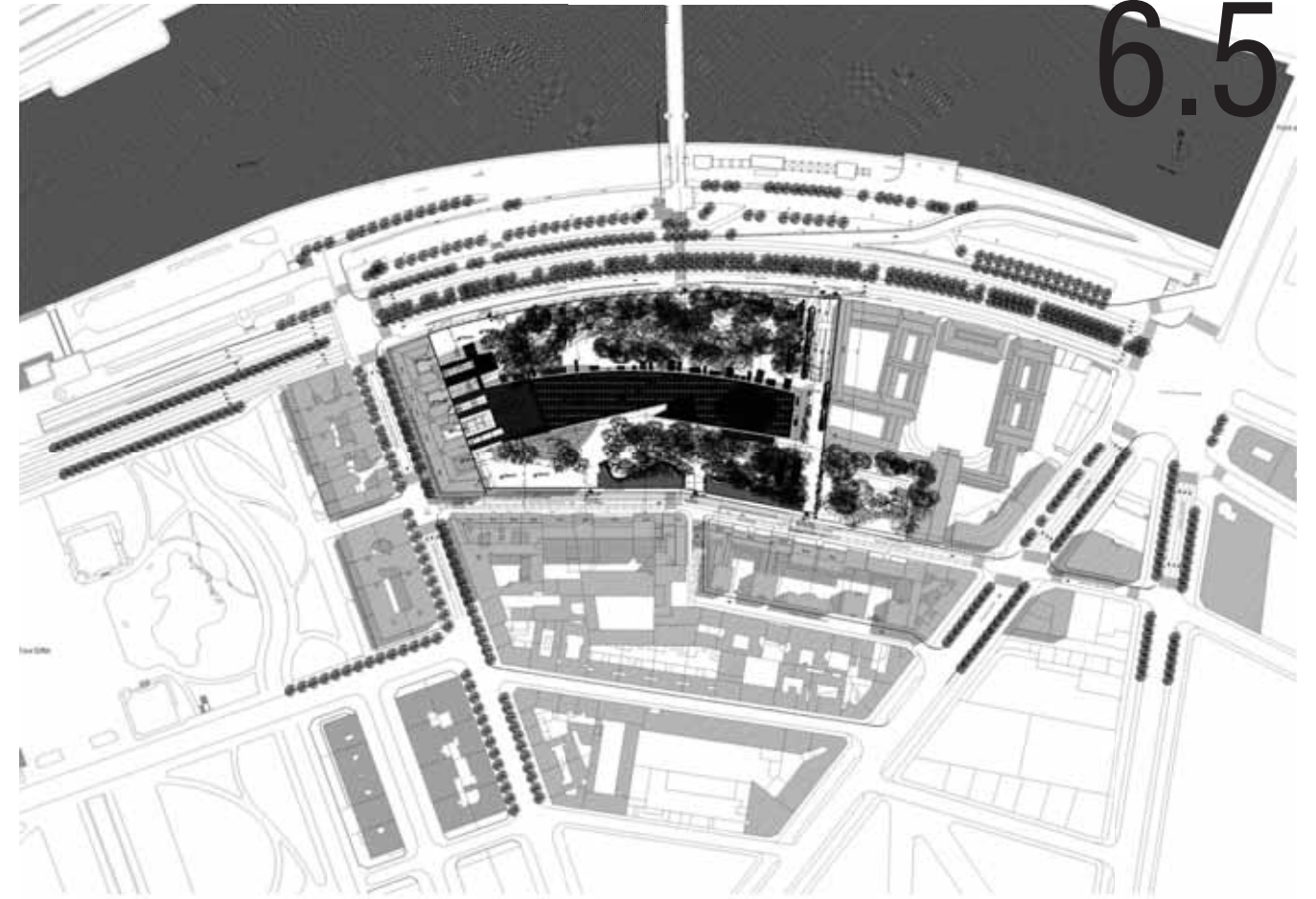
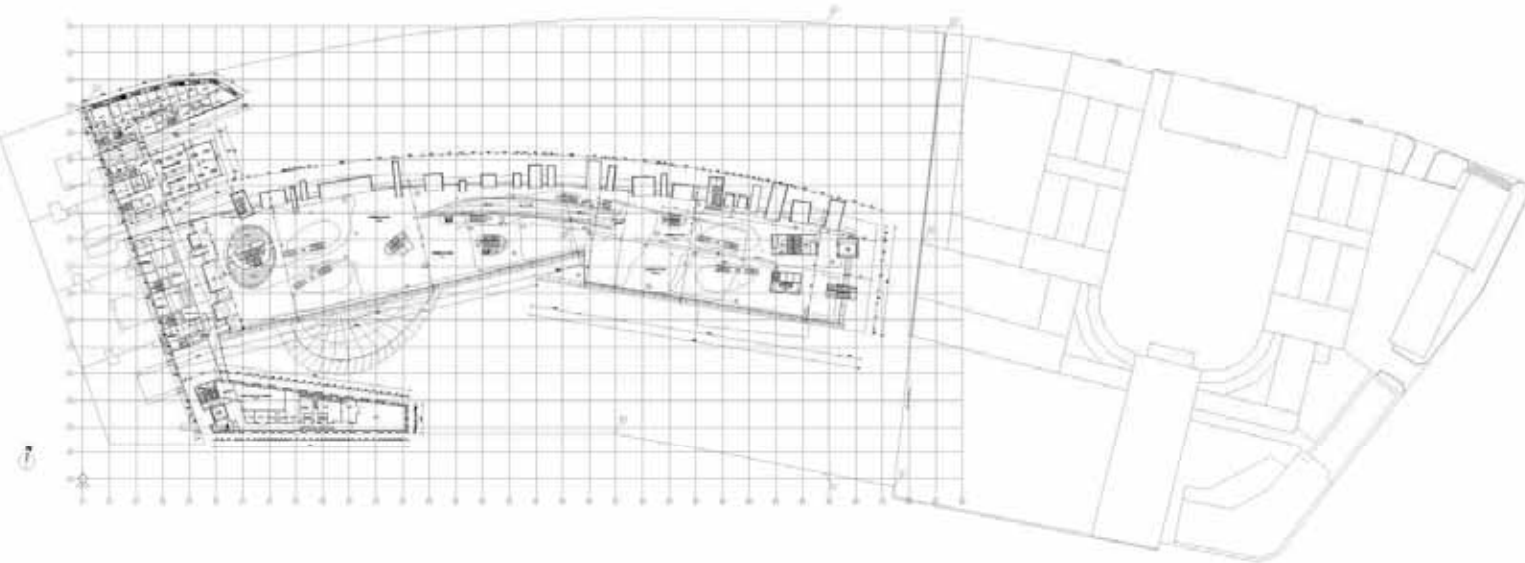

Figure - 6.20- Site Plan indicating how the building grows out of the old buildings.



Figure - 6.21- Photograph from the Eiffel Tower depicting the greater context on the building.



The abattoir does not need to avoid these elements, but can grow from them, clash into them and most importantly revive them into functional objects that can anchor the design.

Figure - 6.22 (Above) - Mezzanine floor plan showing how the building does not only conform to the historical building it is connected to, but also adheres to the axial shift of the building across opposite it.

Figure - 6.23 (Below) - The envelope of the above ground exhibition space consists of a series of adjustable louvres to control the light inside the exhibition. The site is also heavily planted with trees, converting a Parisian garden into a forest with a museum hidden inside.

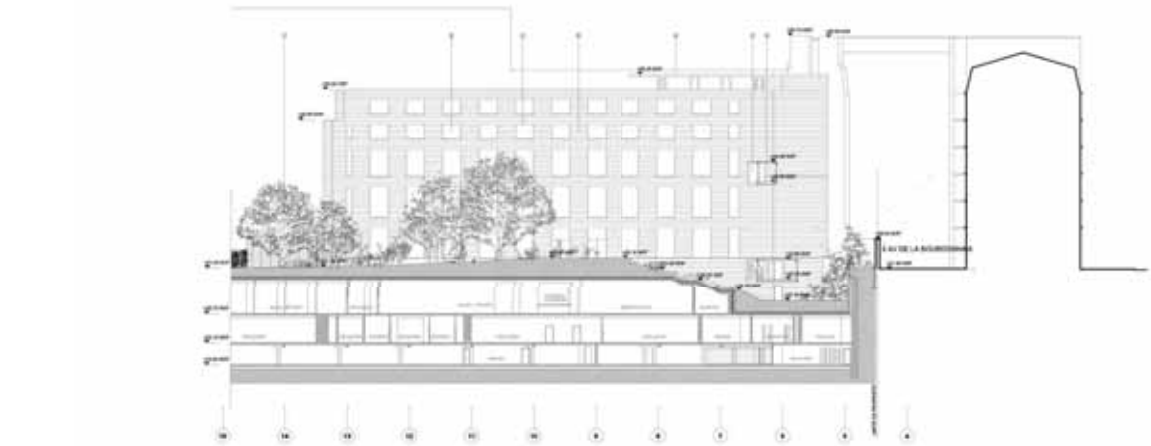

Figure - 6.24 - Section depicting the underground exhibition spaces and its relation to the street.

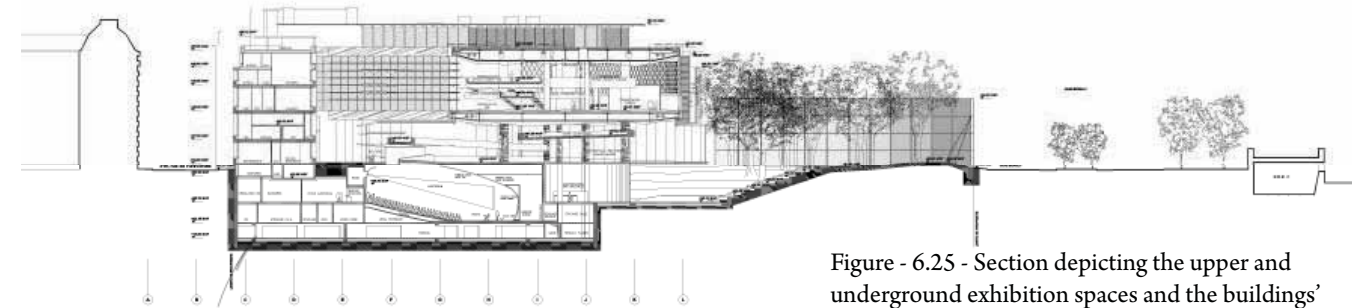

Figure - 6.25 - Section depicting the upper and underground exhibition spaces and the buildings' contextual relationships to the surrounding streets



Figure - 6.26 - The existing building facade is continued, but the new is characterised by large windows and a wall which is completely planted.

TECHNOLOGY

Environmental considerations in the design of a new abattoir at Cranswick Country Foods, Preston, East Yorkshire, 2003 - 2008, Mark Goddard.

This precedent was not chosen for its architectural qualities but for the environmental systems employed in the project. The information listed below is from a presentation by architect Mark Goddard done in 2008.

The abattoir at Preston in Yorkshire was completed in 2008 and makes use of a myriad of systems which mainly focus on:

Energy Recovery

Reduction in water consumption

Energy

Control of emissions

Waste recycling

The following is a brief summary of the technologies employed in the design of the new abattoir.

It was recognised that every environmental aspect of the process required a form of management control to reduce its impact, should it, or a significant part of it, fail. Therefore it was decided that an Environmental Management System (EMS) would be used to exercise the control which included inspection, testing and maintenance of equipment that could be detrimental to the environment. The site now has an integrated management system accredited to both ISO 14001 & BS 18001 (British Standards)

ENERGY RECOVERY

The abattoir process includes the use of gas burners for carcass singeing.

Exhaust gases through the flue generates heat to approximately 450°C.

Installation of a heat recovery system enables water to be heated to approximately 95°C for use in a variety of processes within the abattoir e.g. scald tank, sterilizers and hygiene.

Reduced reliance on gas fired boiler to raise steam & hot water.

Further reduced reliance on electrical elements to heat sterilisers.

Estimated savings of 2.5m kWh per annum 2.5 Year pay back on investment.

REDUCED WATER USE

Reduction in water use have become key to abattoir projects. The Preston abattoir has included the following water efficiency measures:

Use of efficient recycling pumps within the process

Pipe-work reducers to limit flow of water to end users

Water Metering on key equipment

Water metering enables the business to affect control over water use by comparing its use against throughput, thereby limiting cost associated with effluent discharge. Deviations from the base line would be indicative of misuse or leakage.

Methods of waste water treatment to reduce COD, BOD, PH, etc were investigated. This was achieved by adding a biological agent into the drainage system which would then multiply the organisms in the effluent to improve its quality prior to discharge, thereby reducing costs.

6.6

ENERGY

The introduction of the heat recovery system has emphasized how energy can be managed in an efficient manner to see real savings in both Gas & Electricity. In addition to High Frequency lighting being installed throughout the factory, the following improvements were made:

Compressed Air Survey to reduce leaks

Power Factor Correction

Voltage Optimisation

Installation of New Refrigeration Equipment

CONTROL OF EMISSIONS

The new abattoir incorporates an odour control system which includes an air scrubbing/polishing facility. Waste trailers are housed within an air lock. Pipe-work from the slurry tanks and tanker filler point, is also routed through the OCS. All waste from the internal processes are vacuumed directly to the air locked waste area.

The methodology of the system is to treat heavy odour from the waste handling unit and exhaust from the slurry tanks through an activated carbon filter scrubber, which provides additional 'air polishing', reducing the risk of odour nuisance. (Filter medium replaced every four years under normal use). The vacuum system will reduce the necessity of waste handling to further reduce odours, as well as reduce noise nuisance issues as FLT movements will be limited by approximately 75%. Strategically placed land banks, fencing and tree planting are included in the project design to further reduce noise to nearby residential properties

WASTE/RECYCLING

Recycling contaminated waste has proven extremely difficult and there appears to be no waste management company that is able to treat it cost effectively. Consequently, all contaminated 'General' Waste continues to be sent to landfill

A mill sized baler was purchased and used to recycle:

Cardboard

Laminate Film (Skeletal Waste from packaging lines)

This precedent displays the recycling potential within an abattoir. The impact of such systems on the operational cost of the abattoir is immense and can increase the competitiveness, output and profit of the company.

The precedent forms the energy model for the design of the Mamelodi High Street abattoir and by introducing such systems, the building can be liberated of its wasteful nature and become safer and more productive within its public location.

PROGRAMMATIC INTENTIONS AND LEGISLATION

This chapter outlines the programmatic decisions that were made based on the analysis of the slaughtering process and regarding legislation. The chapter contains an overview of the final design and the overall intentions of the project.

Figure - 7.1 - Photograph of carcasses waiting to be inspected (By Author).



PROGRAMME

PROGRAMME VS EVENT

"Programme is to be distinguished from 'event'. A program is a determinate set of expected occurrences, a list of required utilities, often based on social behaviour, habit, or custom. In contrast, events occur as an indeterminate set of unexpected outcomes. Revealing hidden potentialities or contradictions in a program, and relating them to a particularly appropriate (or possibly exceptional) spatial configuration, may create conditions for unexpected events to occur.

(Tschumi, 1987, p. 48)

The dissertation investigates the abattoir in a more public context and therefore the programme is to be conceived as a series of events setting up a dialogue with its surroundings and establishing a public discourse. The typical compact process of production is to be stretched out linearly into a sequence of events where at any moment the public can interpose and bear witness.

INTRODUCTION

Historical attempts to industrialise the slaughtering process at the cost of humane treatment of animals and hygienic conditions under which the meat is slaughtered and processed, has led to legislation setting out basic parameters to which the new abattoir must comply. The dissertation proposes to reintroduce the abattoir into a densely populated area, therefore these factors come under extreme scrutiny in the design of the abattoir. The legislation and the setting of the abattoir influence the general layout and the circulation.

The programming legislation as published by the Red Meat Association of South Africa and the Department of Agriculture, is adhered to and can be found in Addendum A. The legislation only provides a minimum compliance and the design strives to improve the conditions for the animals and workers alike. The

design proposes a feedlot to be erected on the open agricultural land across the road from the site which is to serve both private and public interest. This allows the transportation of the animals to be removed from the process, which eliminates injuries to animals during transportation and also decreases the carbon footprint added to the slaughter process by extensive distances which these animals have to be transported. The setting of the abattoir in a more densely populated area reduces product transportation, further reducing carbon loads.

The abattoir strives to harmonise working conditions by allowing for ample natural daylighting and by introducing courtyards to assure not only north and south light but also views from the building. Further, the design aims to facilitate a medium to large scale production line, which is directly fed from the feedlot.

The civic role of the abattoir is augmented through a series of output pavilions which recycles the general animal waste of the abattoir and reworks it into marketable products for public consumption. The pavilions are situated directly on the new high street and establish a platform for engagement between the abattoir and the public realm. The design realigns the consumer and the product and establishes a sense of ritual and sacrifice to an otherwise industrial process.

The public interface allows for active surveillance of the slaughtering process and helps to reduce malpractice and cruelty to animals as well as unsustainable habits regarding wastage.

The size of the facility is designed to accommodate the slaughter of 75 to 300 head of cattle per day, with most of the slaughter taking place from 06:00 am till 10:00 am (average slaughter time of Gauteng abattoirs). After the slaughter process, the output pavilions will become active and serve the public realm



Figure - 7.1 - Mechanical slaughter versus ritual slaughter and the sequence of events (By Author).

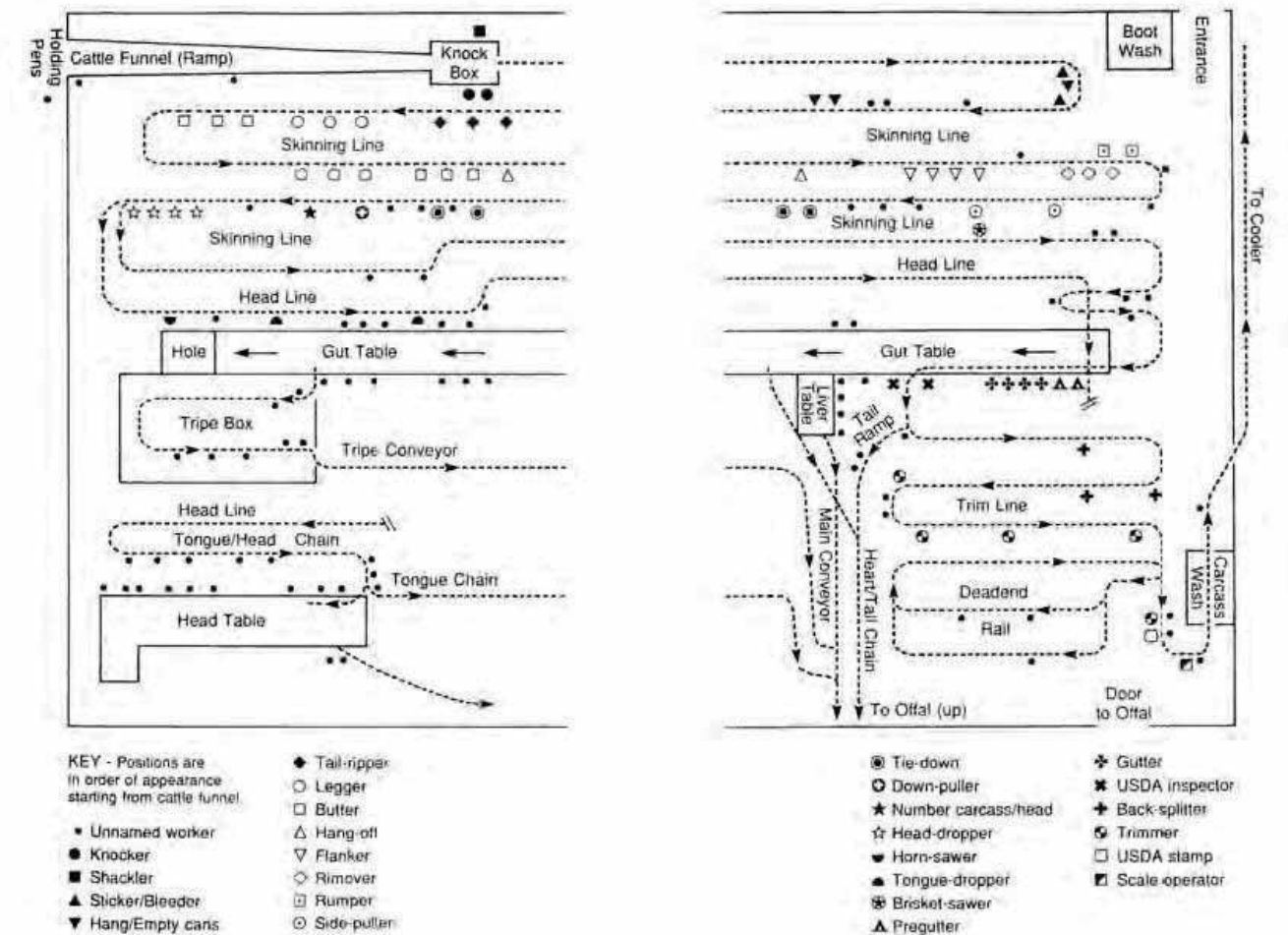

Figure - 7.2 - A detailed layout of abattoir processes .

by providing processed materials to local producers. The design also accommodates facilities for local producers to buy, sell and reproduce from these products.

GENERAL GUIDELINES SET OUT BY THE DEPARTMENT OF AGRICULTURE

General:

The facility should be of such a design, construction and finish, and must be equipped in such a condition and so located that they can be used at all times for its intended purpose, without creating a health hazard. This must be done in such a manner that meat can be processed hygienically on the premises and can be protected by the best possible equipment against spoilage of any kind.

Premises:

The premises must be of such a design that it is rendered dust and mud free. The abattoir must be equipped with an enclosed drainage system for the disposal of effluent and sewerage. All loading areas must be curbed, paved, drained and roofed.

Cross Flow:

The design of the facility must ensure that clean and dirty areas are separated with no cross flow between them. Condemned or inedible meat must be stored separately and must be inspected without coming in contact with other meat.

Requirements for interior of building rooms:

In the abattoir where meat and animal products are handled, all other human amenities, the rooms must be of such size as not to compromise hygiene. All floors and stairways are to be smooth, impervious, hard wearing and non slippery. Surfaces are also to be joint and crack free. Floor drainage design must ensure that floors are sloped at a gradient of no less than 1:80 towards drainage points, and the drainage should happen in the direction of clean to dirty areas. All interior surfaces must be smooth, impervious and washable. All working areas must be well ventilated and have artificial and natural lighting of at least 540 lux where meat is processed and 220 lux in other work areas.

Lairage:

The minimum requirements for lairage capacity states there should be a minimum of 1.75 m² allowed per head of cattle (cow). Lairages must be equipped with permanent floors that are curbed and drained for ease of cleaning, without obstructing the flow of animals. All surfaces which receives animal traffic are to be non slippery and drains are to be covered. The minimum width of the lairage passages is 1.2 m wide for cattle and should be completely free of loose objects. All holding pens must have gates no less than 1.8 m high and must be equipped with water troughs 900 mm high for cattle.

Stunning, Hoisting and Bleeding:

To comply with the humane restraining of animals prior to stunning and bleeding, an approved stunning box and a holding pen with minimum dimensions of 2 m x 2 m and a hinged gate should be provided which reduces floor space.

For the stunning of animals, a silenced captive bolt stunner is required or approved electrical alternative. Equipment to hoist and bleed stunned animals must be provided. The blood from the bleeding process must be collected and stored in closed containers prior to removal. For cattle bleeding, the minimum rail to floor dimension should be 4.4 m in the case of a fixed rail.

Dressing and Evisceration Facilities

The minimum clearance for rails and equipment in these areas are 3.4 m from floor to rail. Carcasses should at all instances not be closer than 1000 mm from any wall or piece of equipment. Rails with hooks are to be 400 mm from any wall, and carcasses are not to touch the floor or wall. Rails should be 700 mm from columns, pillars or the side of any doorway.

Meat Inspection Facilities

These facilities should be equipped with racks, platforms and any other equipment required for meat inspection. Marked and leak proof lockable containers must be provided for condemned meat prior to disposal.

Chillers:

The chillers room must be designed to hold at least the entire slaughter of the day. All rails in the chillers should be a minimum distance of 1000 mm from the walls and carcasses should be spaced at a minimum of 660 mm from each other to ensure

A SPACE/PLACE FOR SLAUGHTER

The process of slaughter consists of two distinct parts, namely; a dirty process which embodies the process from stunning up until splitting, after which it is replaced by the clean process which, consists of inspection up to and including the packaging process.

These two processes require completely different spaces; the dirty process requires a much more hardwearing type of space, whilst the clean process requires a hygienic controlled environment. The abattoir is to focus on the slaughter of bovine only. The process and accommodation will be designed for services surrounding the slaughter of bovine and the recycling of the waste concerning this process.

The processes housed in a bovine abattoir are as follows: lairage, stunning, bleeding, extremity removal, head removal, skinning, evisceration, splitting, inspection, chilling, cutting, deboning, processing and packaging.

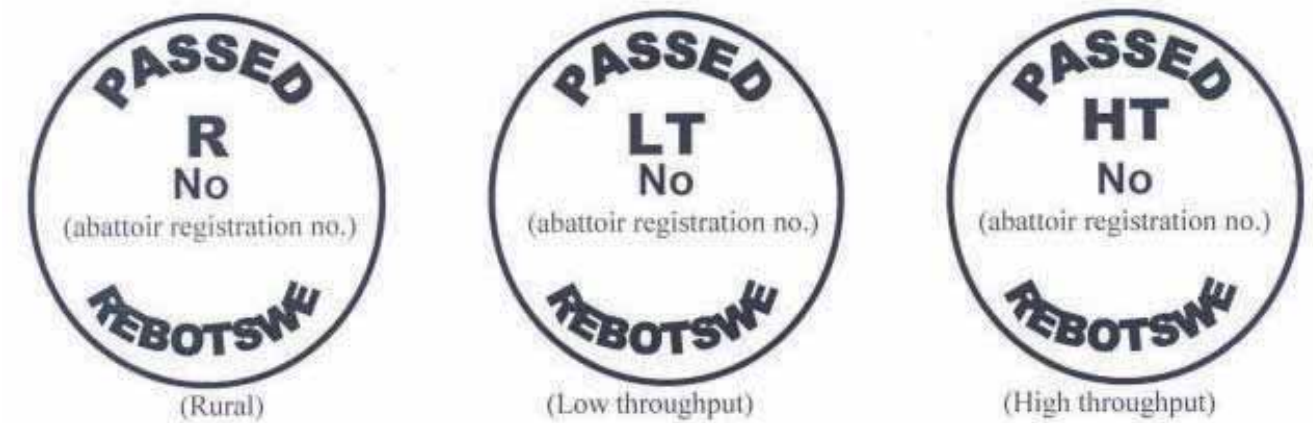

Figure - 7.3- Meat grading stamps prescribed by the Department of Agriculture

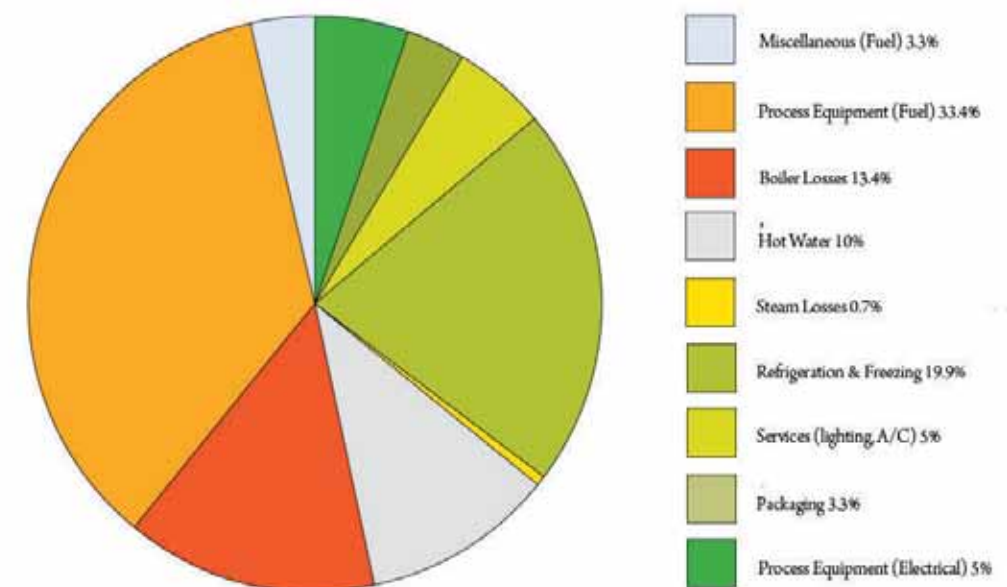

Figure - 7.4- A pie chart indication the different types of electrical consumption within a typical abattoir.

proper air flow.

Dispatch Areas

Dispatch areas are to be properly equipped for quartering, mar-shalling and loading of carcasses or processed meat.

Temperature Control:

The air temperature in the cutting hall must be 12 degrees Cel-sius or less. During cutting, wrapping and portioning of meat, the core temperature of the meat must be maintained at 7 de-grees Celsius or below.

TECHNOLOGICAL ISSUES / OPPORTUNITIES

Water Use / Supply:

The abattoir requires a pressurised water connection according to SANS 241 standard for drinking water. Water points with cold water, hose pipe connections with a minimum of 40 de-grees Celsius for sanitizing all areas of the abattoir and hot water at a minimum temperature of 82 degrees Celsius in sterilizers for disinfecting hand equipment, need to be supplied.

Recycled grey water can be used for the general cleaning of the abattoir, but not for the washing of the carcasses. Water can be put through the anaerobic process and a series of UV and mi-cropore filtration systems to achieve potable water. Therefore, a closed loop water system, independent from the municipal sewer, must be used to recycle and reuse as much water as possible.

Heating and Cooling:

Abattoirs require large amounts of cooling for the chillers, de-boning and packing halls. The average temperature during operational hours should not exceed 12 degrees Celsius and therefore requires constant cooling. Therefore the design of an abattoir should not only rely on mechanical systems to cool spaces, but also look at passive design to take the load off these mechanical systems. A vast array of different refrigeration sys-tems are available, but for this dissertation the absorption chiller is used within the closed loop recycling system (Further dis-cussed in the technology chapter). The absorption chiller uses waste heat to power the system and will be used in conjunction with a biogas digester from the waste recycling and geothermal

pipes situated on the roof of the abattoir. The absorption chiller uses significantly less energy than other compressor based re-frigeration processes. Some key characteristics of absorption chillers:

- Employs heat and a concentrated salt solution (lithium bro-mide) to produce chilled water.
- Eliminates ozone depleting refrigerants. Water is the refriger-ant; lithium bromide is the absorbent.
- Uses the lithium bromide solution’s high affinity for water (hy-groscopic properties) to create a high vacuum in the evapora-tor/absorber. The vacuum causes the refrigerant (water) to boil at 2 °C or 36°F.
- Absorption refrigeration cycle uses very little electricity com-pared to an electric motor-driven compression cycle chiller.
- Allows use of various heat sources: directly using a gas burner, recovering waste heat in the form of hot water or low-pressure steam, or boiler-generated hot water or steam.

Waste Recycling:

The design proposes a closed loop recycling waste system, which is to utilise all waste from the abattoir. Organic waste, which cannot be processed into by products, will firstly be sent to an on site electro coagulation plant, to remove suspended or-ganic matter and nitrates, and then to a bio-gas plant situated in the tri-generation area of the scheme. Here all organic matter will be converted to energy via methane reactors, which in turn will power the absorption chiller refrigeration plant through the waste heat produced.

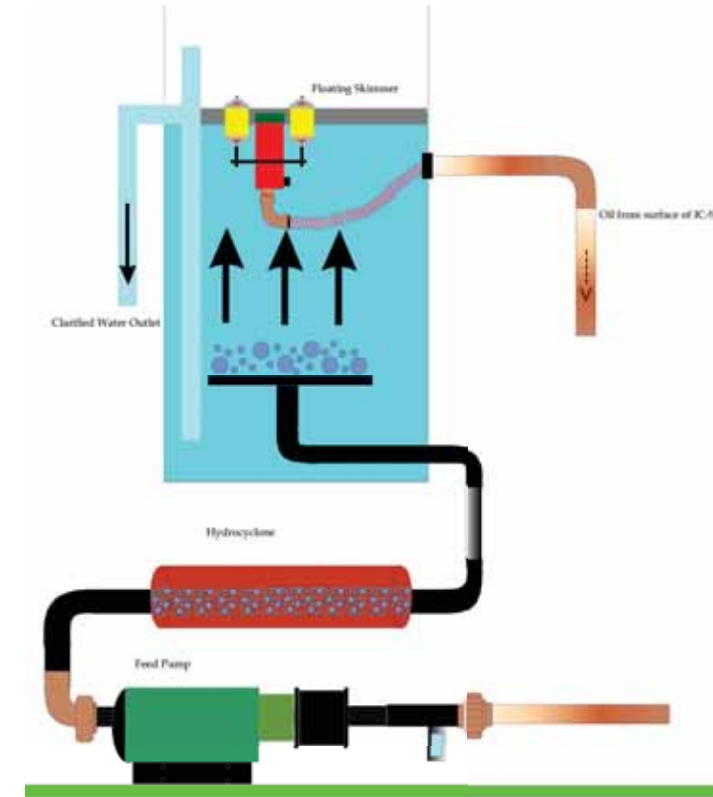

Figure - 7.5 - Example waste water treatment - Deoiling IC-SEP* System.

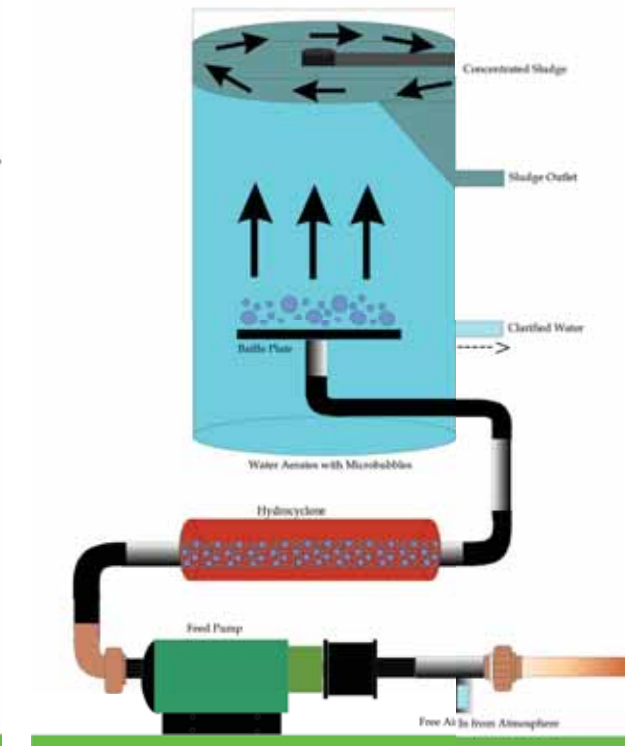

Figure - 7.6- Example of waste water treatment - Solids Removal IC-SEP* System.

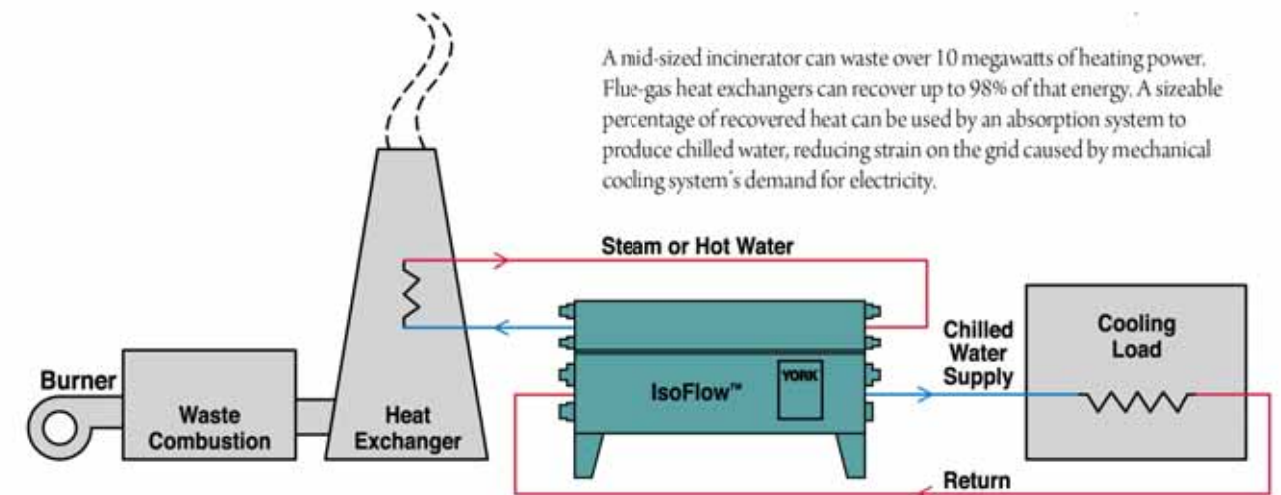

Figure - 7.7- Waste heat recovery system.

DESIGN DEVELOPMENT



Figure - 8.1 - Photograph of a floor drain in the Rietvlei Abattoir (By Author).

DESIGN INFORMANTS

The design of an abattoir has to firstly conform to numerous legislative elements which dictates certain aspects regarding general layouts and flow of the spaces. Not only does the positioning of the abattoir in the public realm require a fine balance between legislation and design, but also the strong heritage of the site needs to be addressed. A series of informants were identified at an early stage to direct the design process:

Legislation:

The abattoir firstly has to adhere to the legislation set out by the Department of Agriculture and the Red Meat Association.

Production:

Abattoirs are production lines and require a detailed process orientated layout to aid in the success and ease of production.

Orientation:

For optimal environmental performance, the building needs to make use of the site's northern orientation for day lighting and thermal performance.

High Street:

To test the hypothesis, the building has to interact and establish a relationship with the high street that edges the site on the northern boundary.

Heritage:

The site was chosen due to its strong industrial heritage of which there are remains scattered around the site. The framework proposal is based on historical activities in and around the precinct and therefore the design of the abattoir should continue and reinforce this relationship with the past.

Environmental Performance:

As previously stated, abattoirs are extremely resource intensive and produce large amounts of waste. Addressing these factors in the design of the abattoir are of utmost importance, not only to achieve a sustainable energy efficient design, but also to create a seamless introduction of the abattoir into the public realm. These factors need to be satisfied in order for the building not to become a health and safety hazard.

Regenerative Principles:

The Hannover principles as previously discussed is to incorporated into every design decision to aid the design in an regenerative architectural direction.

PART 1: THE SITE

The completion of the development framework resulted in a triangular site situated on the high street. The site contains two of the underground bunkers used for the distilling of whiskey on the southern side and is flanked on the east by the new heritage development and ceremonial square.

On the western side, other side of love drive, a new feedlot is proposed as an upgrade of the existing informal cattle farming taking place on the site. Animals are to be lead directly into the abattoir from the feedlot, eliminating vehicular transportation of animals.

On the north eastern corner of the site, the new pedestrian entrance, which acts as a direct link (underneath the rail) to melodi, is located. The site is therefore perfectly situated to interact with the high street, the pedestrian entrance, heritage on site and the new feedlot. The building must now be designed as to establish relationships with these four elements and inte-

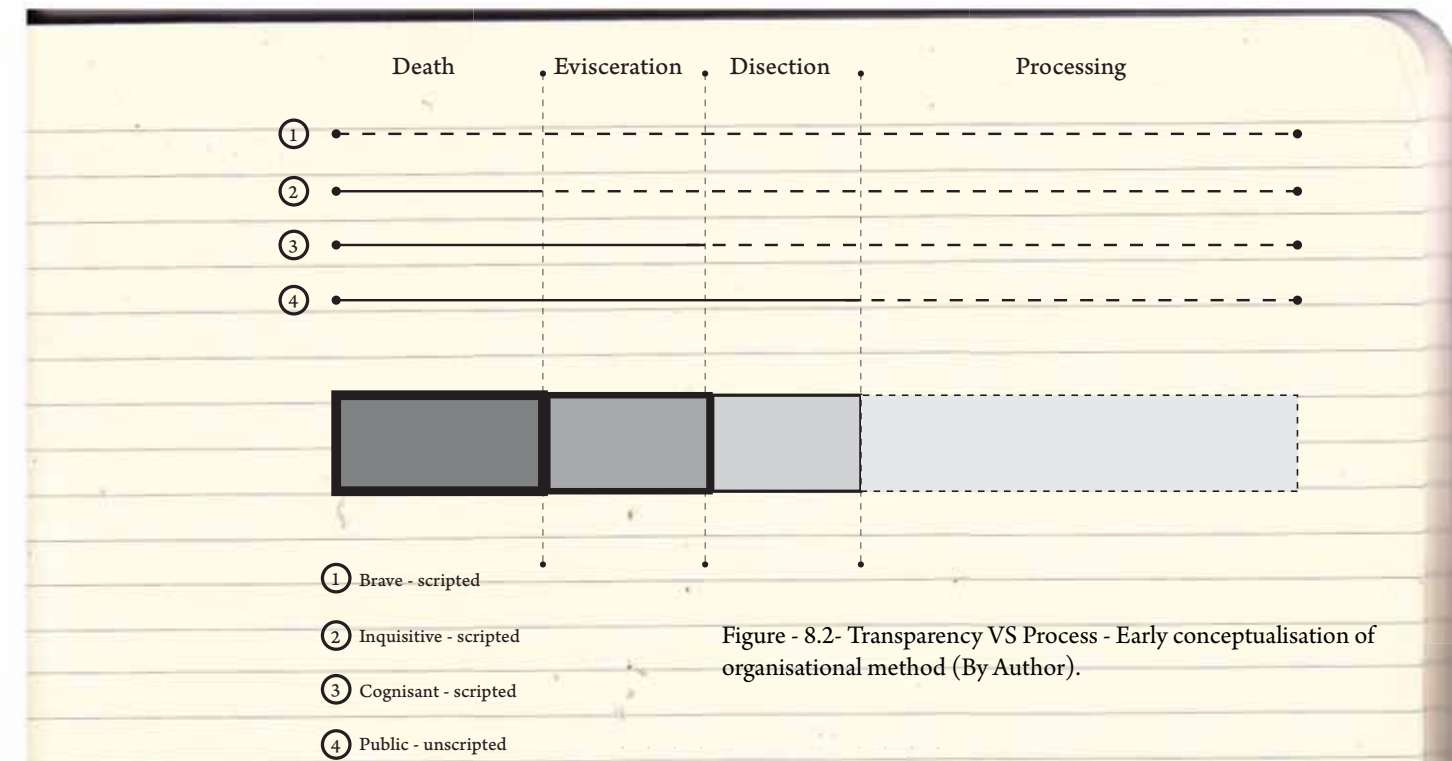

Figure - 8.2- Transparency VS Process - Early conceptualisation of organisational method (By Author).

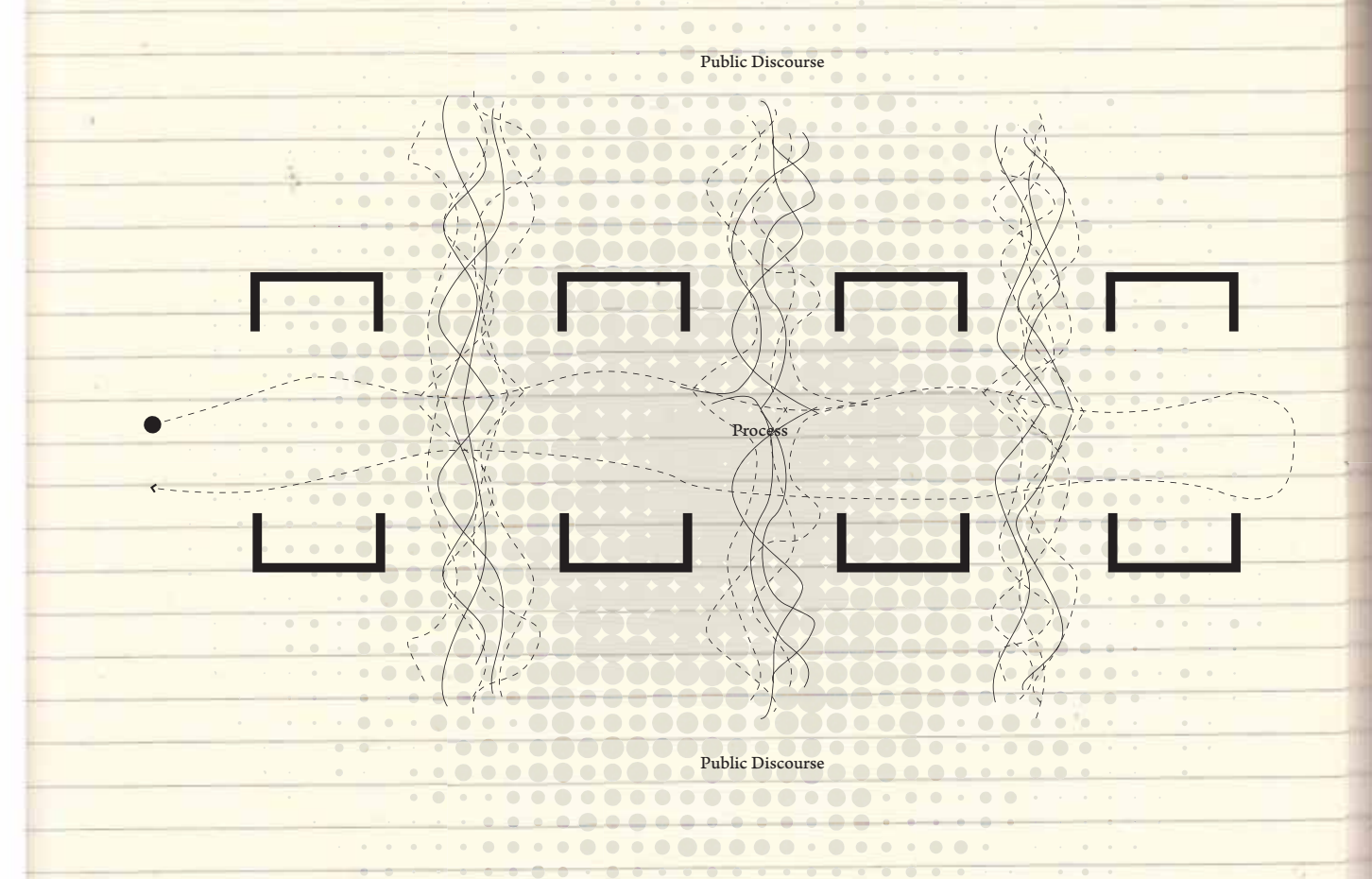

Figure - 8.3- Rhythm - Establishing a sequence of hiding, and showing the abattoir to the high street (By Author).

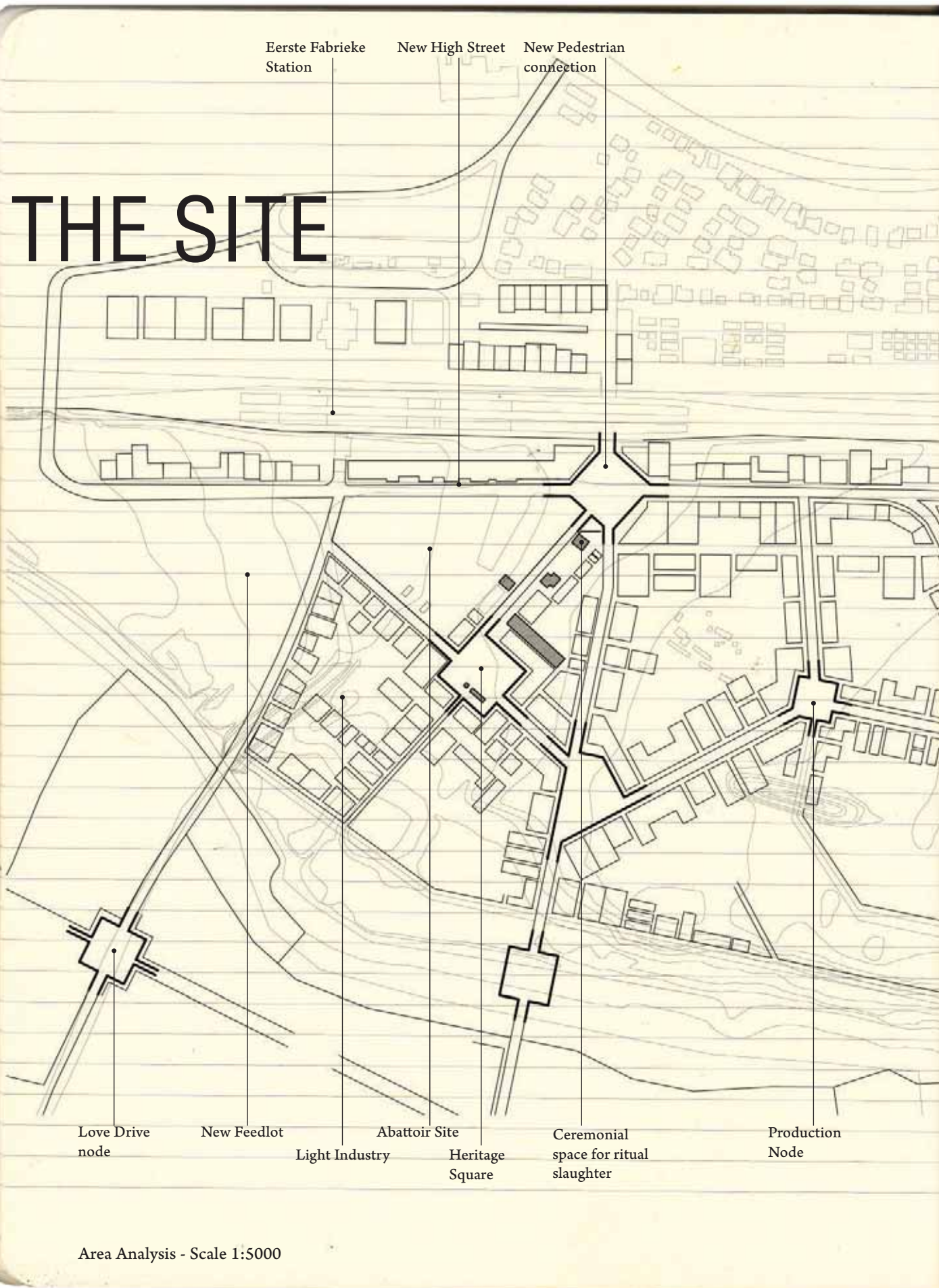

Figure - 8.4- Area plan with important contextual elements (By Author).

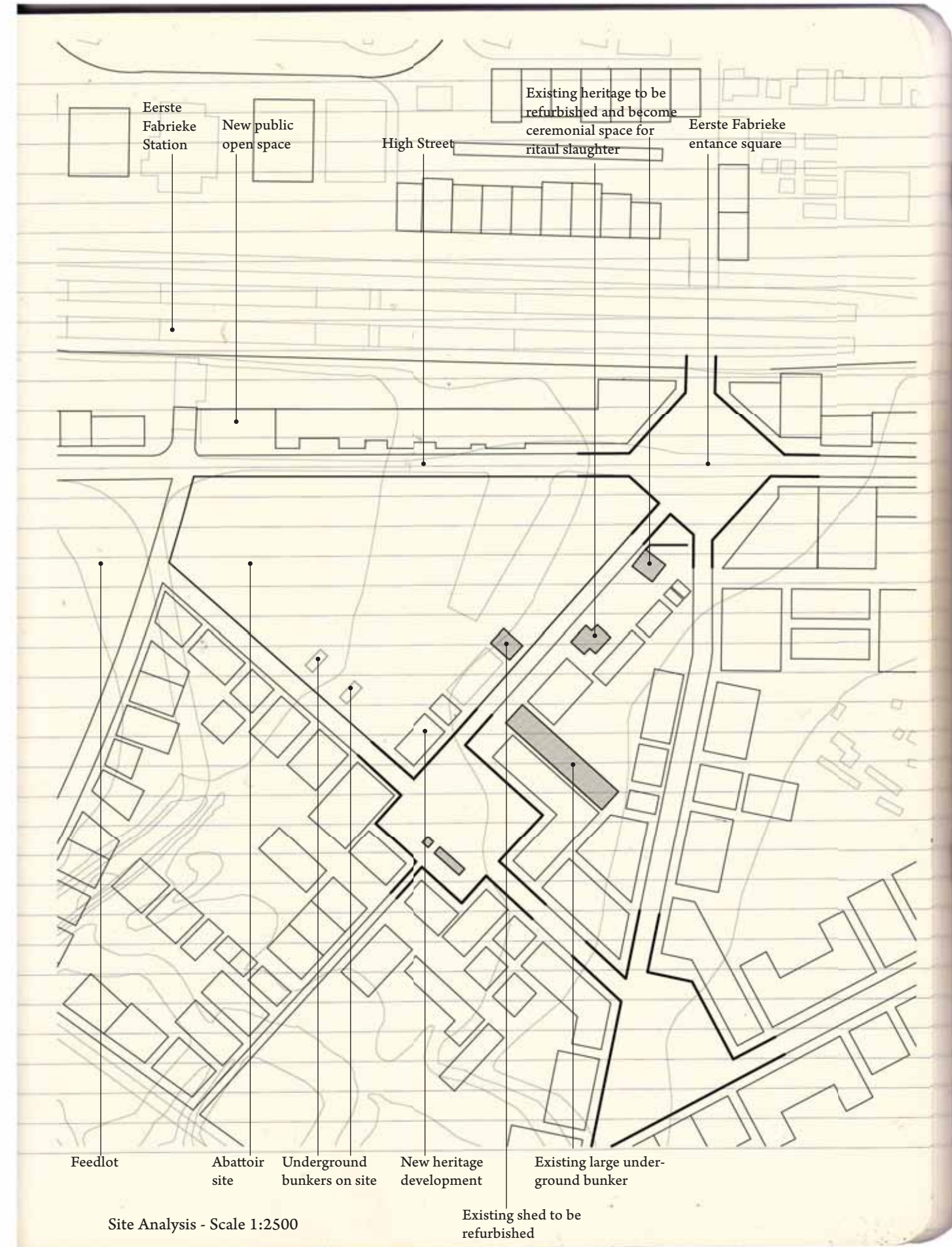

Figure - 8.5- Site plan with important contextual elements (By Author).

PART 2 : CONCEPT

The first conceptual development established a series of connections along a linear process to the high street on the northern side and the heritage on the southern side. The initial response was to recess the slaughtering pit or the dirty process into the ground to relate to all the sunken chambers on site and also to control heat gain in the abattoir.

The conceptual model shown in fig 8.6 - fig 8.10 on the right shows the linear sunken slaughter pit covered with a series of connections which was conceived as human processes over production process. The string shows product in from the feed-lot situated on the western side of the site and product out into the meat market at the eastern edge. The white cubes are the public spaces which engage with the abattoir creating a direct platform for engagement.

On the northern edge the high street was conceptualised as a constant condition against which the changing nature of the linear production line would be juxtaposed. At this stage the southern edge was to be programmed as an heritage area and another constant condition against which the design could be juxtaposed.

Diagrammatic explorations followed attempting to translate the concept into architecture. The exploration started with a literal translation of the concept model which is based on a layering of processes.



Figure - 8.6- Conceptual photograph - A linear process (as shown by the light) with relationships established over it (By Author).

The concept was to establish four layers namely:

Animal / Slaughter Process

Workers Circulation

Public Interaction

Product Circulation,

and to layer them over one another with intersections between all four. The process was conceptualised linearly as to make it possible for the public to interject at any point. Fig 8.2 shows an early concept of transparency vs process with regard to public discourse and Fig 8.3 depicts a concept of establishing a rhythm of displaying and hiding the abattoir at times.

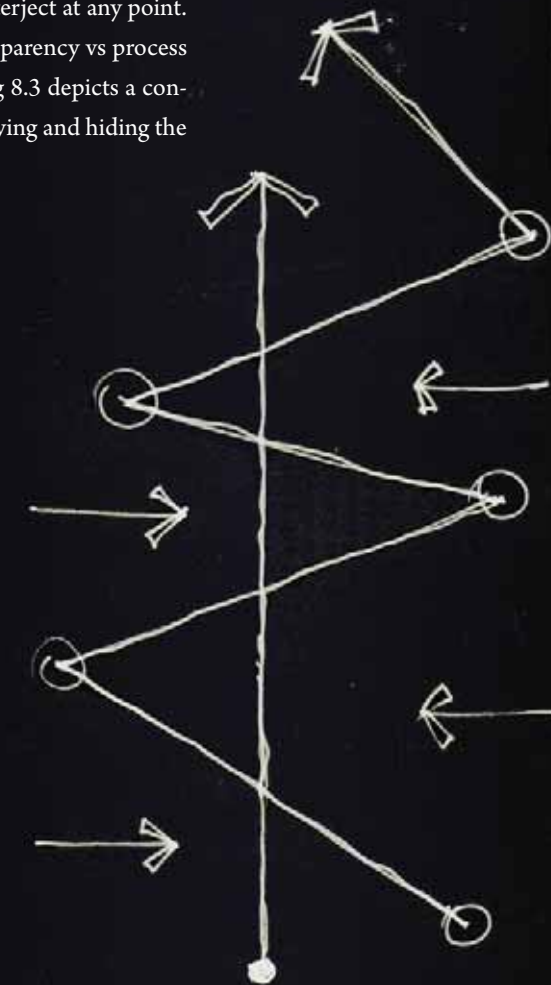

Figure - 8.7- Conceptual diagram. A reinterpretation of fig - 8.6.

CONCEPT

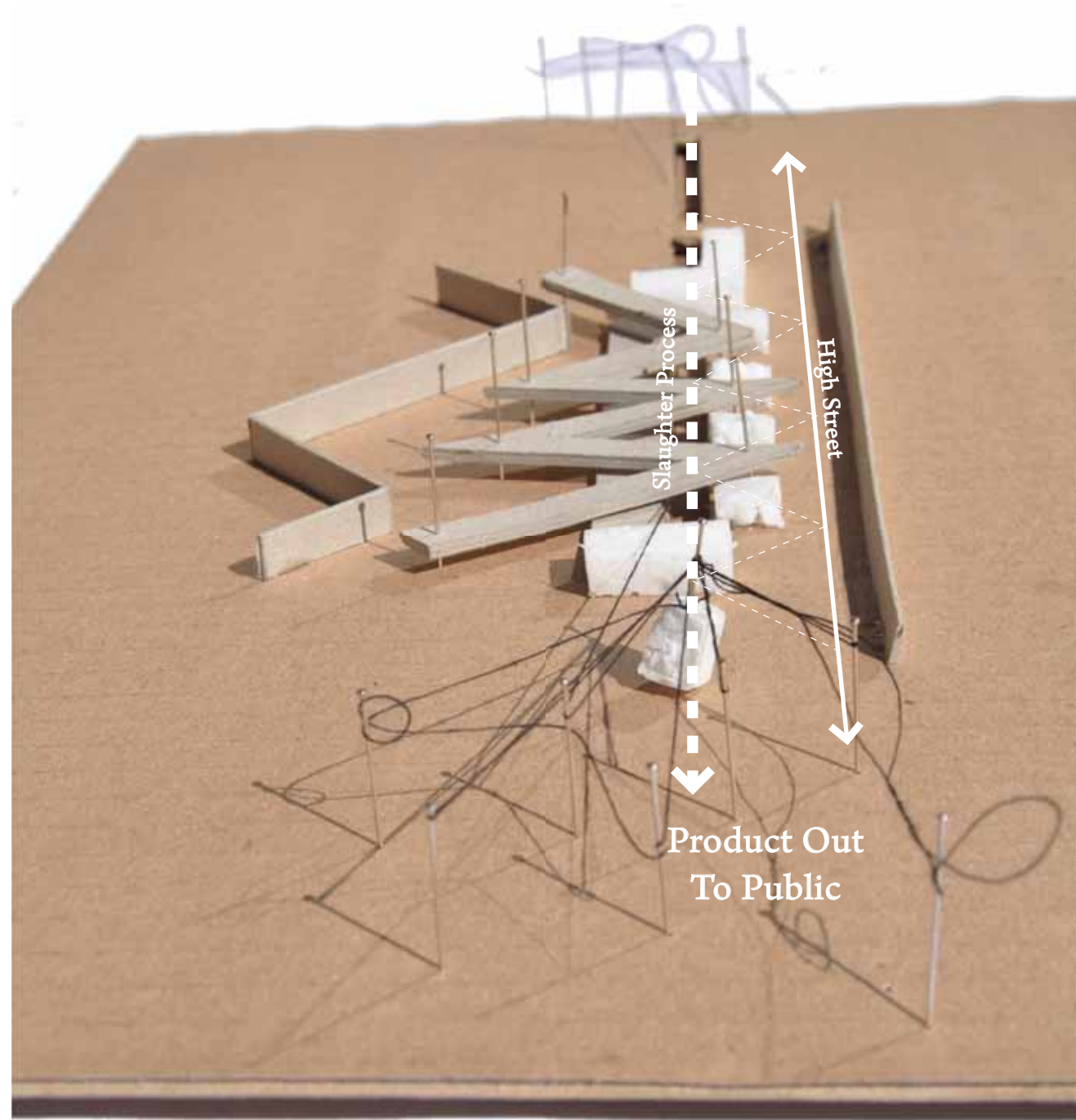

Figure - 8.8- Conceptual model one "Connections" - View looking west - Constant interaction needs to be established (By Author).

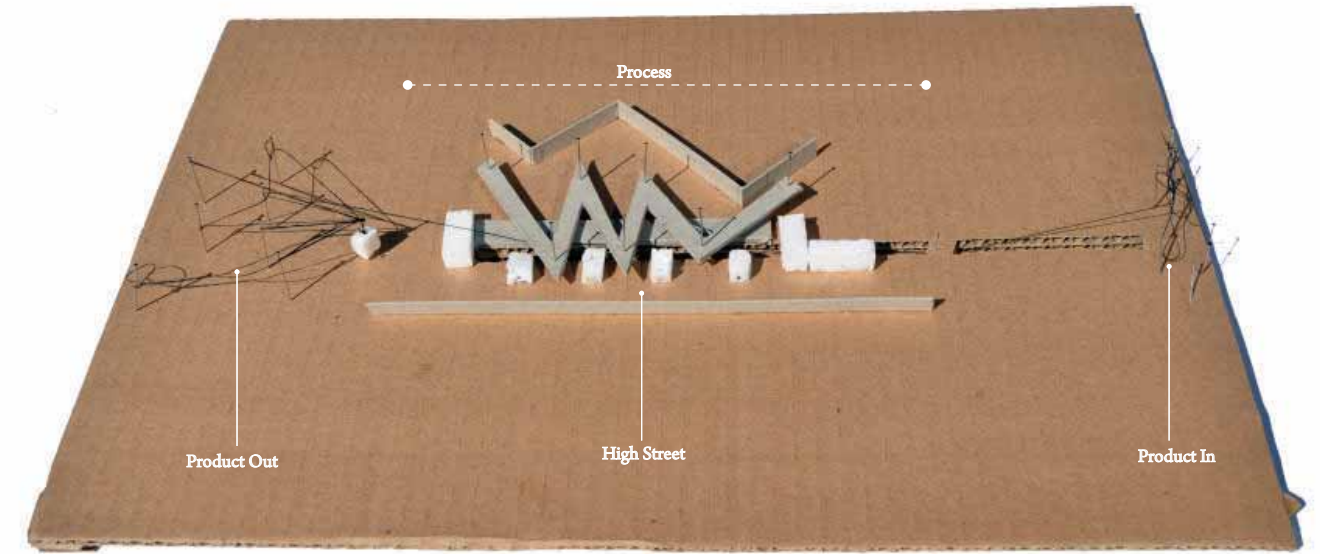

Figure - 8.9- Conceptual model one "Connections" - View looking south at the high street interface (By Author).

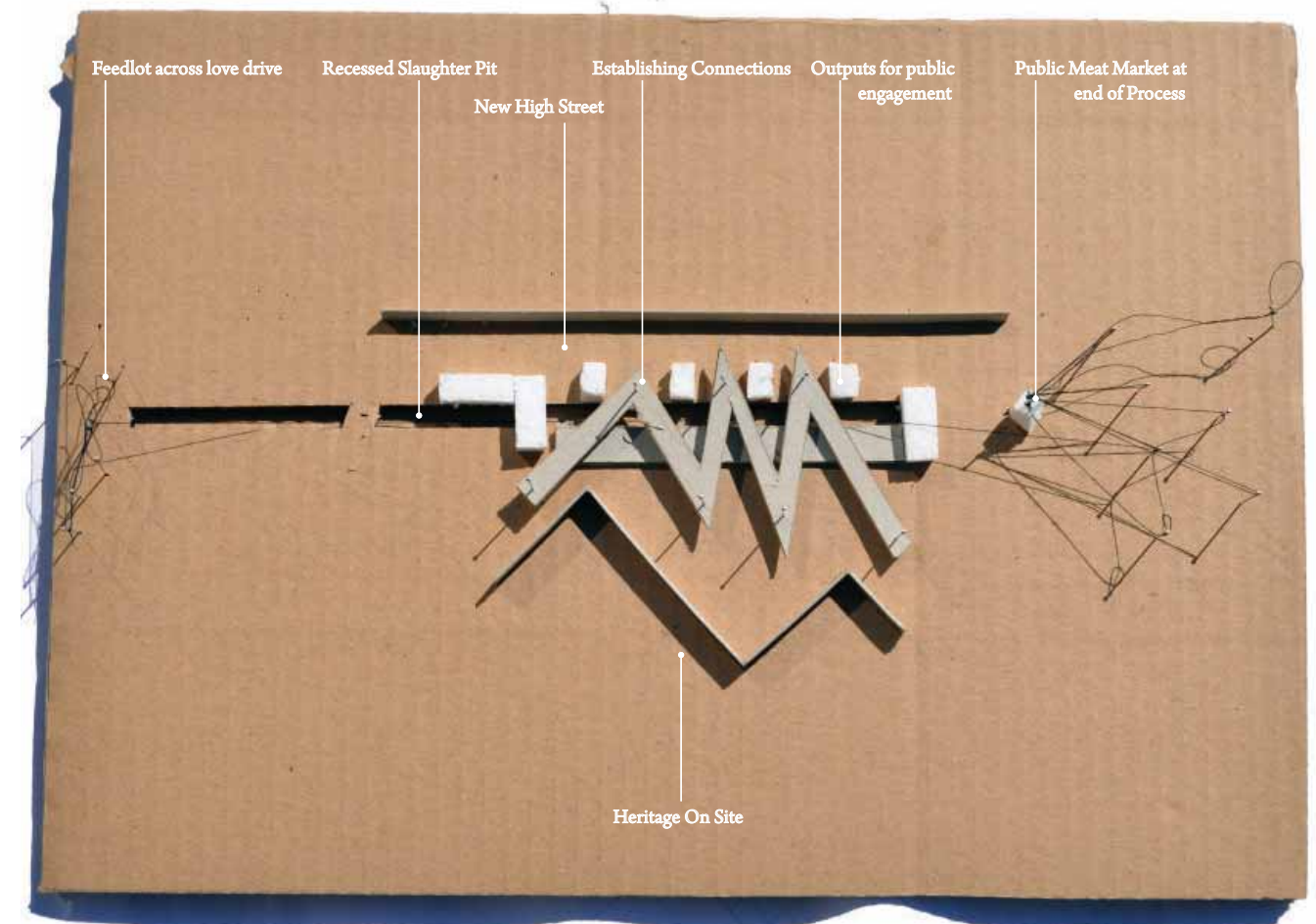

Figure - 8.10 - Conceptual model one "Connections" - Plan view (By Author).

PLANNING

8.3

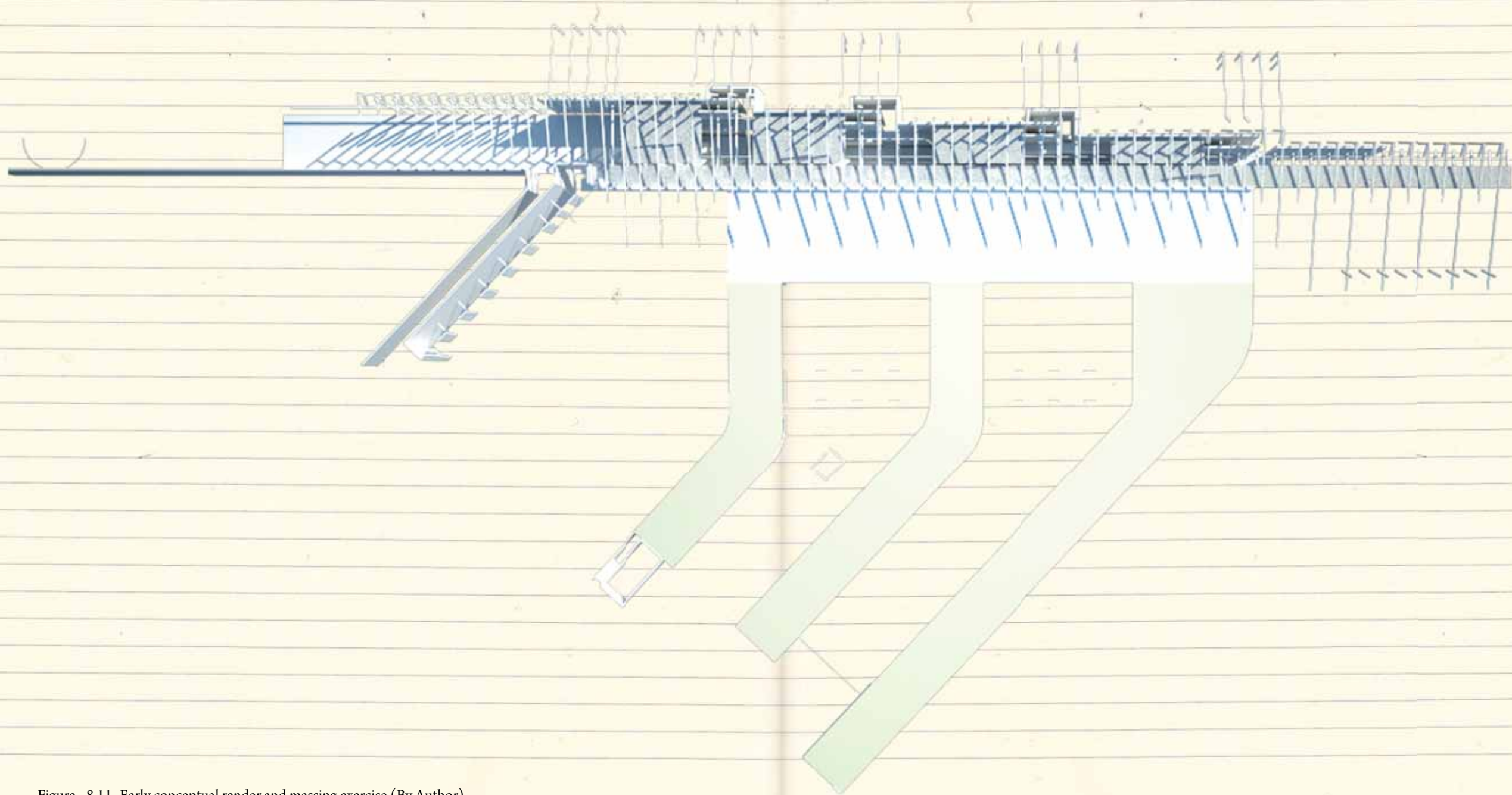

Figure - 8.11- Early conceptual render and massing exercise (By Author).

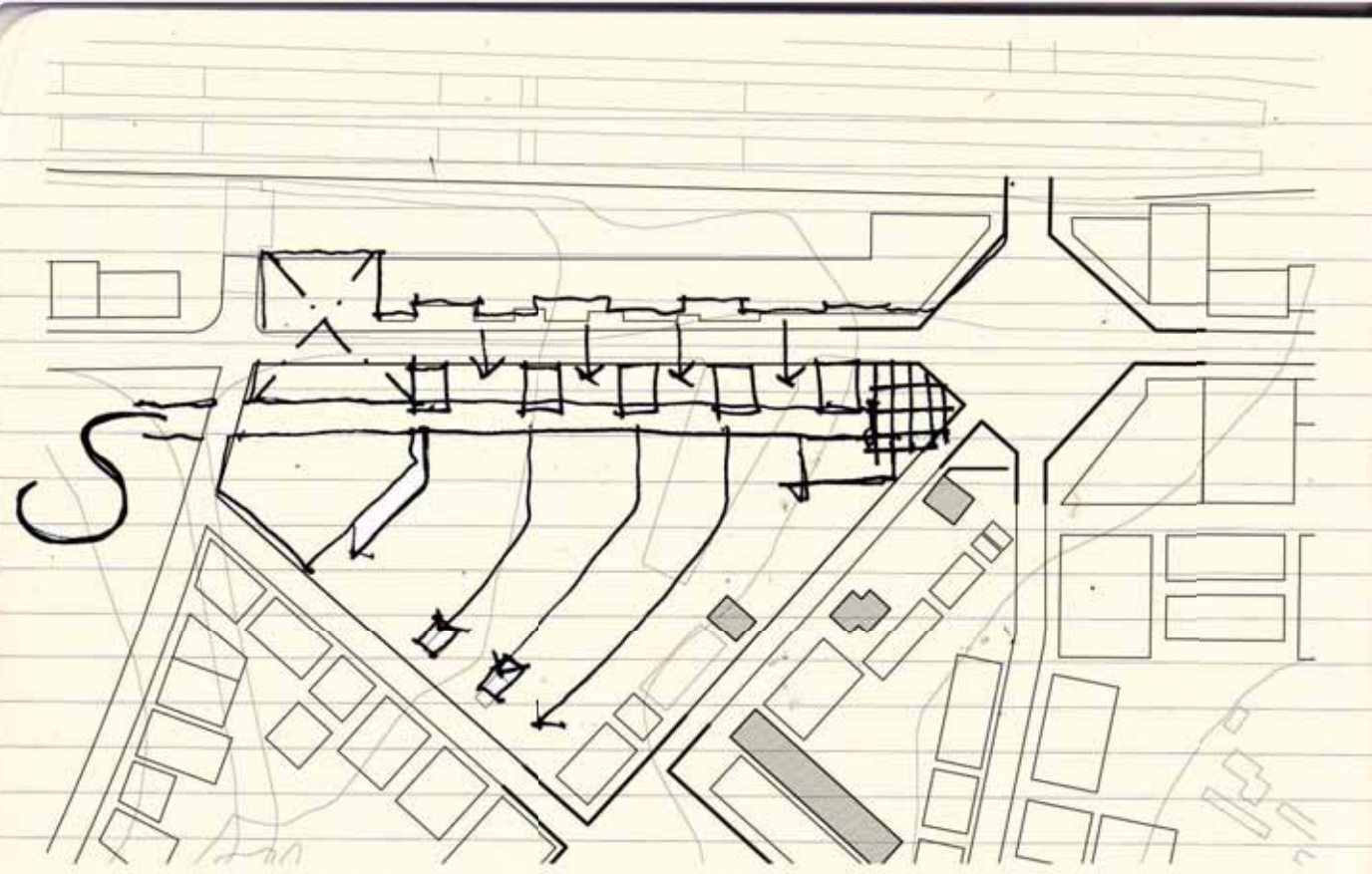

Figure - 8.12- Conceptual diagram of important connections. A linear process is established with identification of connections to the heritage on the south western edge.

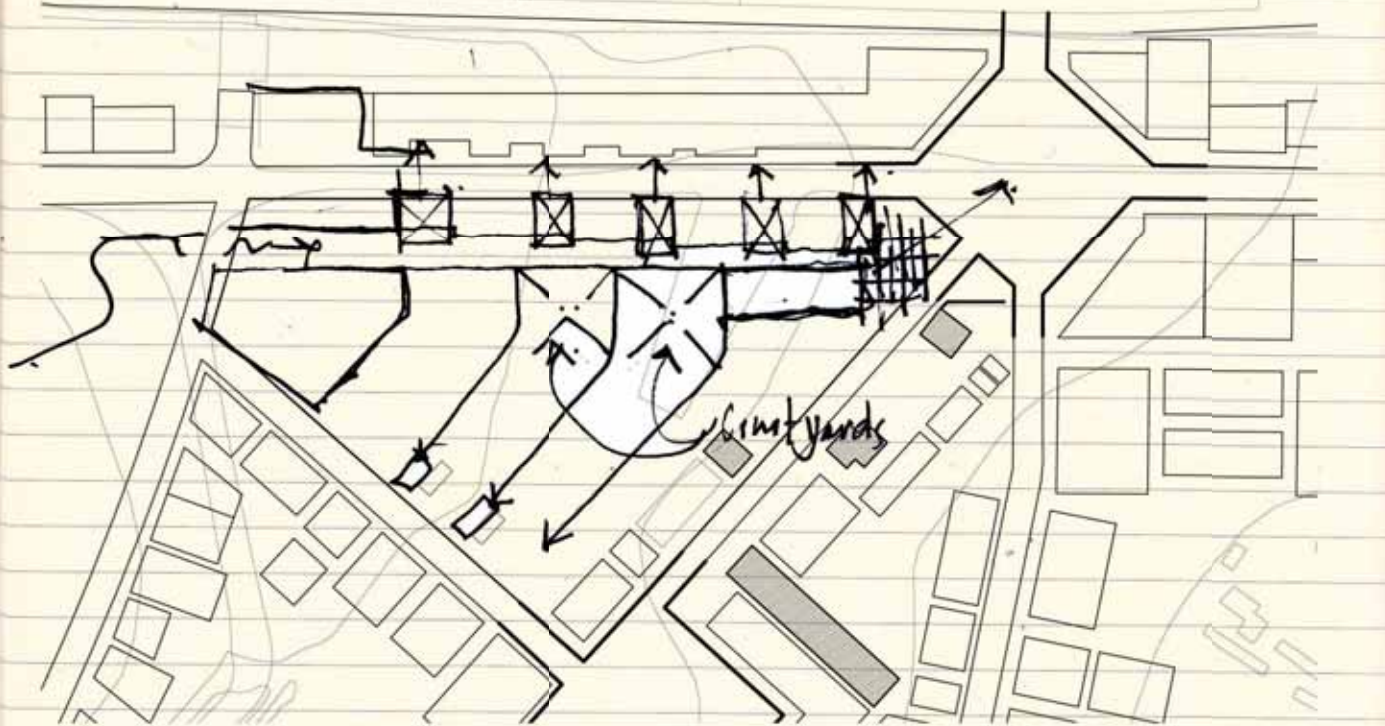

Figure - 8.13- Conceptual diagram exploring further relationships between connecting elements and separate pavilions, which interact with the high street (By Author).

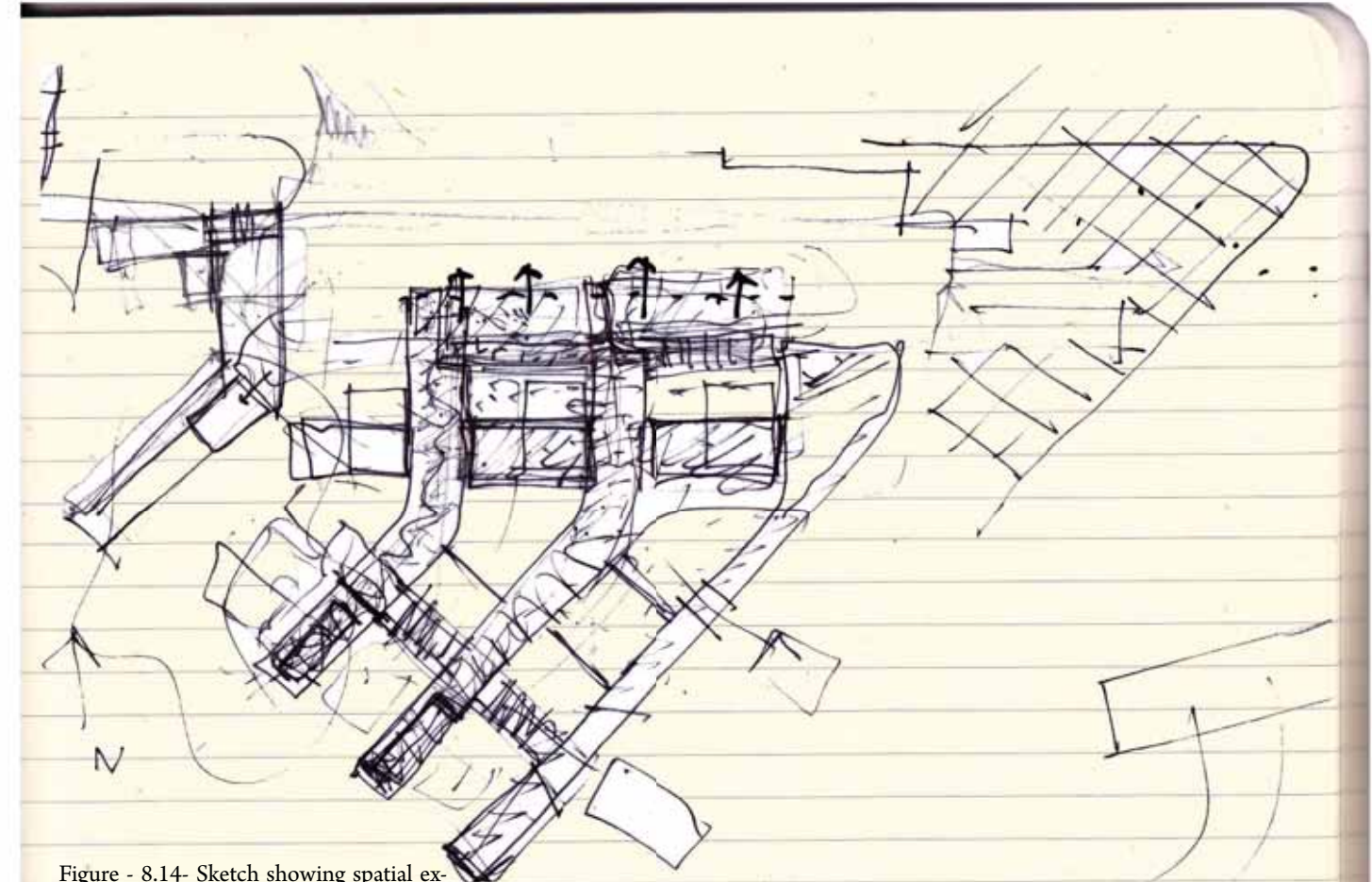

Figure - 8.14- Sketch showing spatial exploration of connecting elements. The possibility of courtyards between these elements can allow for southern light to enter and create views out of buildings, aiding the humanisation of the space (By Author).

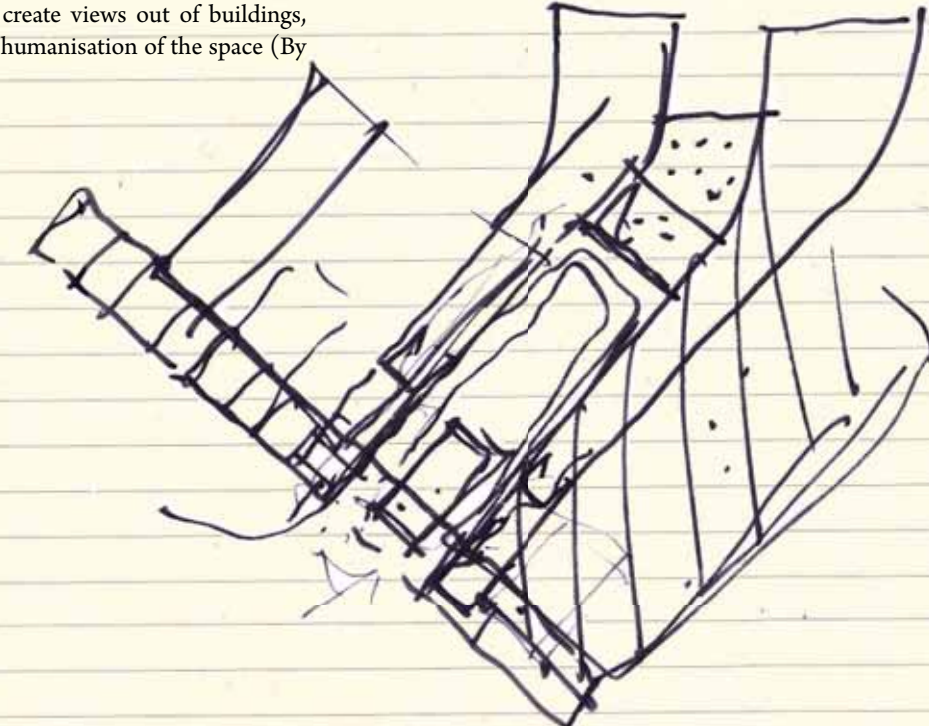

Figure - 8.15- A more detailed look at the connecting elements - possibilities of creating recreational spaces for employees, entrances and other employee orientated programming (By Author).

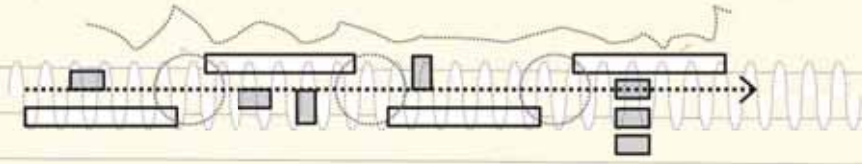

Figure - 8.16- A Sequence of early diagrams explored the design of the process. Firstly, the linear process with spaces clipping onto it was developed. The line at the top represents the unscripted public process (By Author).

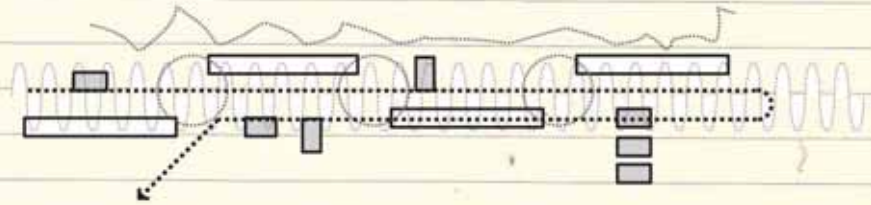

Figure - 8.17 - Secondly, the process is to return on itself, so that the bottom half of the site can be utilised and connected with the heritage. (By Author).

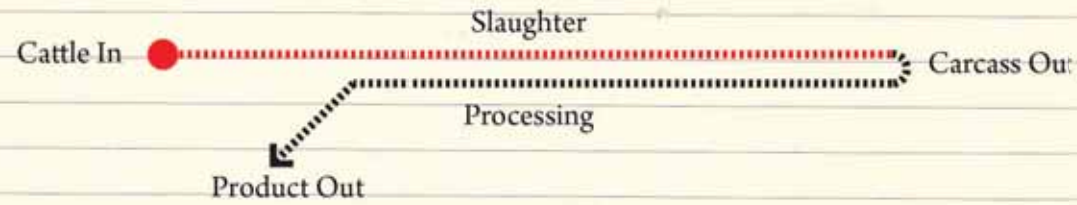

Figure - 8.18 - The process was then defined - The slaughter process will be parallel to and against the high street with the returning line comprising of the meat processing (By Author).

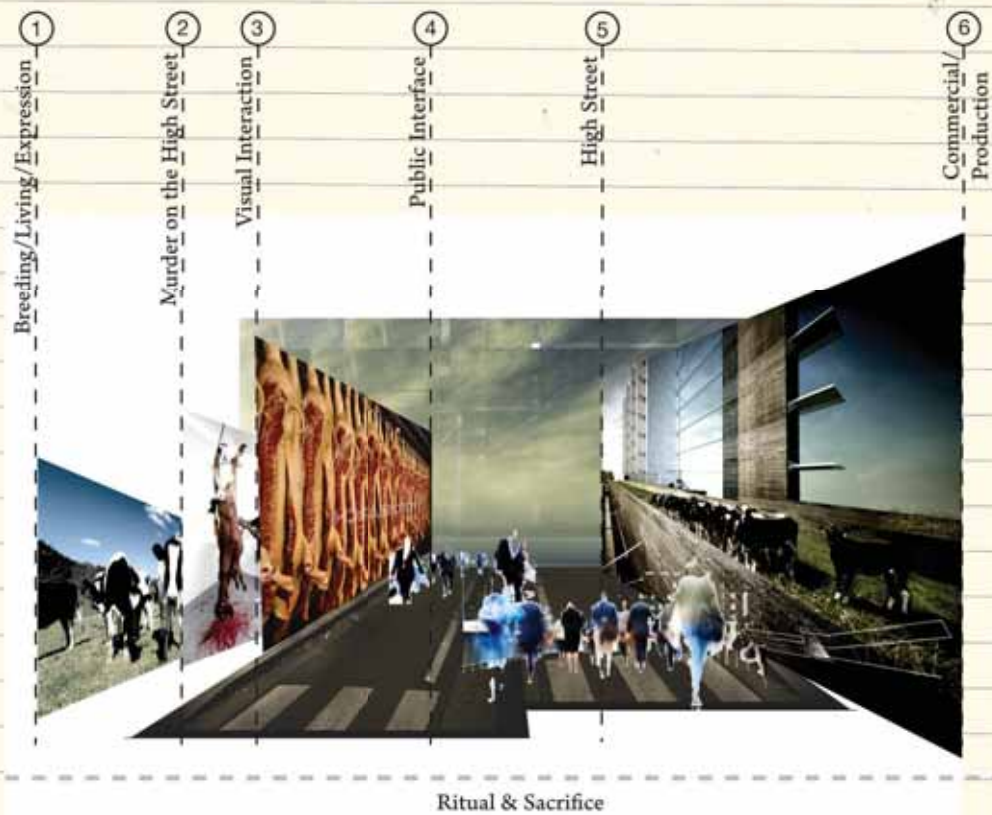

Figure - 8.19- A layered interface - Early conceptual diagram illustrating a multiple layered facade with which the public can engage to the level they wish. This was later translated into the output pavilion model (refer to fig 8.18) (By Author).

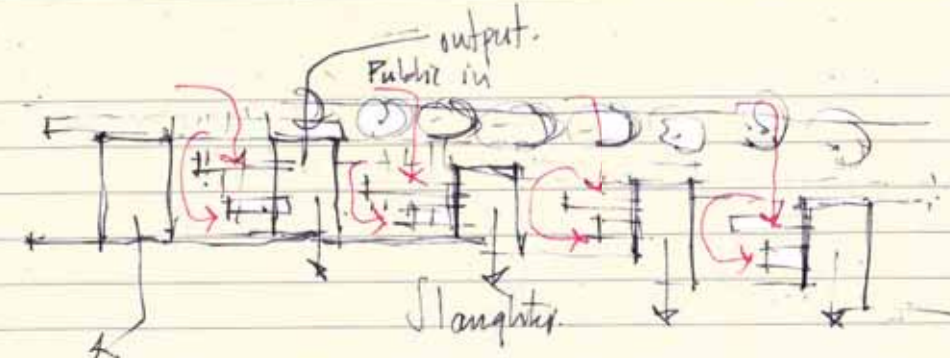

Figure - 8.20 - Output Pavilions - Conceptual Sketches - These pavilions establish a platform for engagement with the public. There are to be five platforms intersecting with the high street. The closed space is to be conceived as the space where the animal by-products get sanitised (so that it can be processed outside without posing any hygienic threat), the in between spaces are based on the spatial quality found in harbours, where fresh fish gets processed and sold directly to the public (By Author).

x5

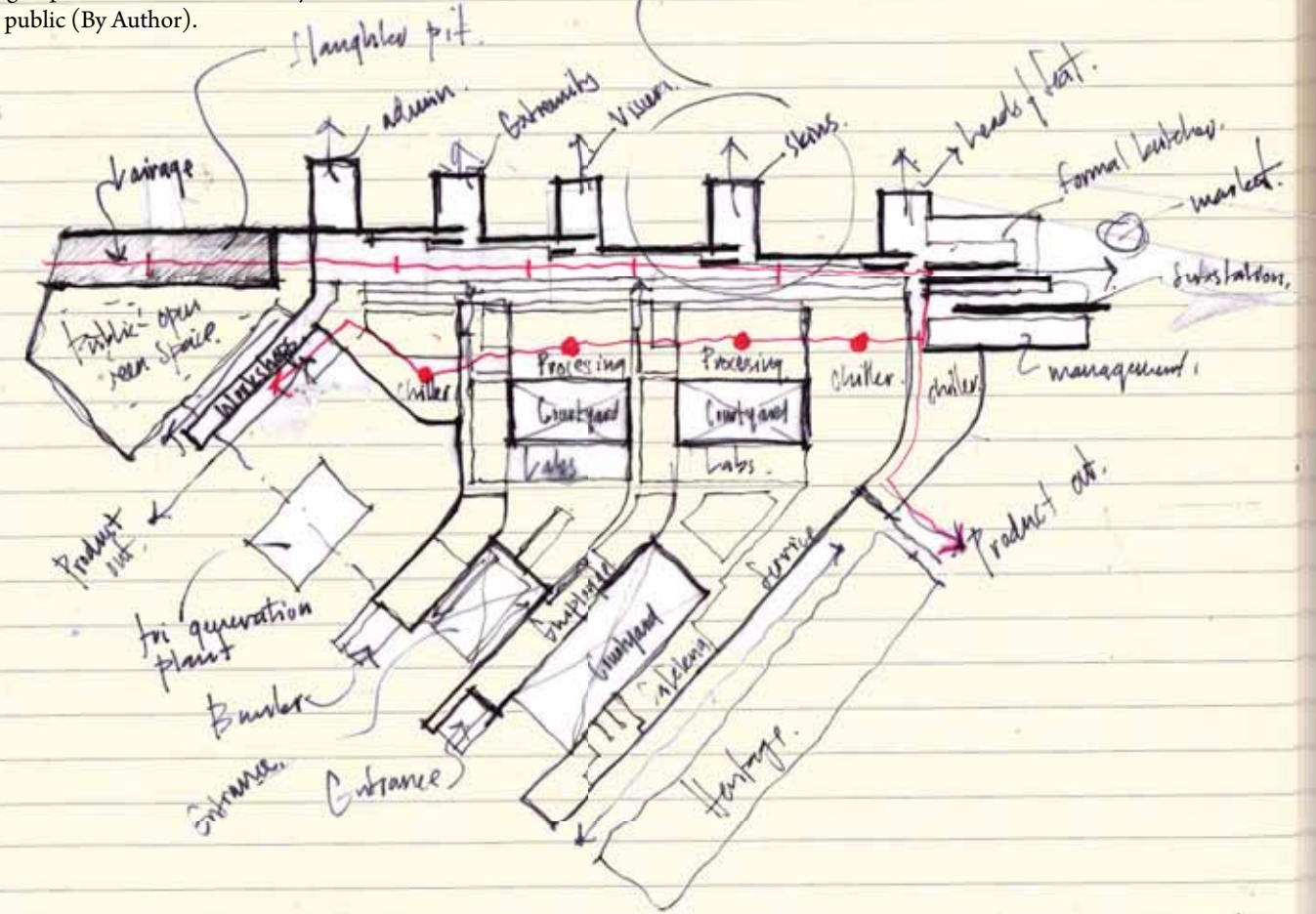
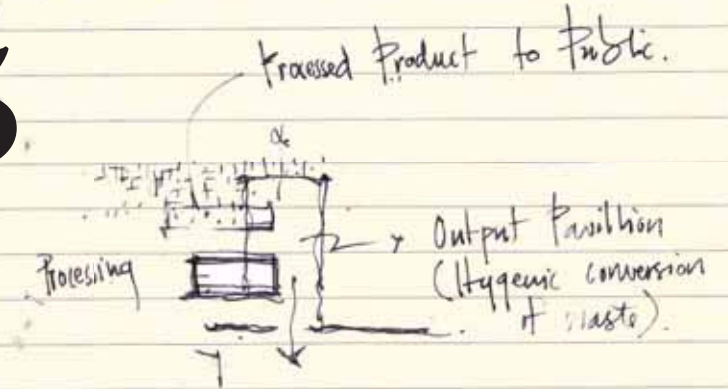

Figure - 8.21- Further diagrammatic exploration of the spatial potential of the linear process and the connecting elements attached to it. A clear form and general organisation starts to develop.

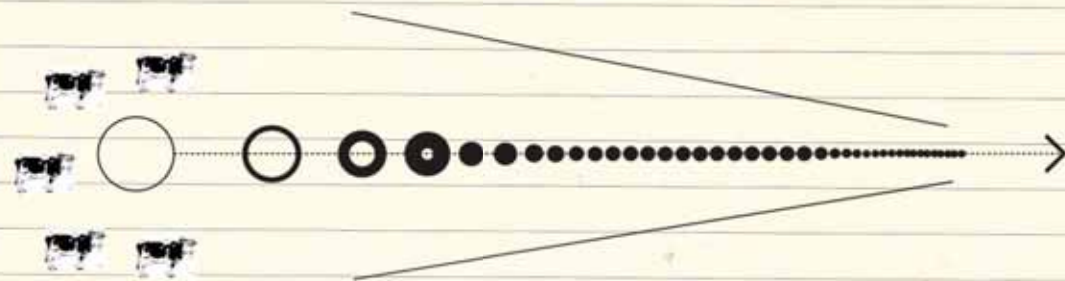

Figure - 8.22- Concentrating a process from a natural environment to a processed environment. Conceptual diagram (by Author).

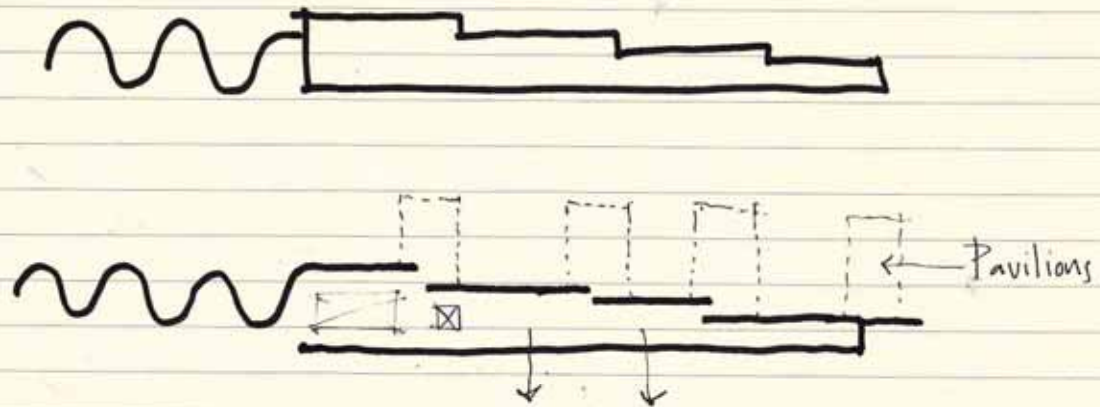

Figure - 8.23 & 24- Diagrammatic exploration of slaughter pit plan. The diagrams explore the concentration of the process. As spatial requirements become less at the end of the slaughter line the pit narrows. This results in a steeping northern edge, which translates as the wall separating the public from the slaughter process. These steps create places for the pavilions to clip onto (by Author).

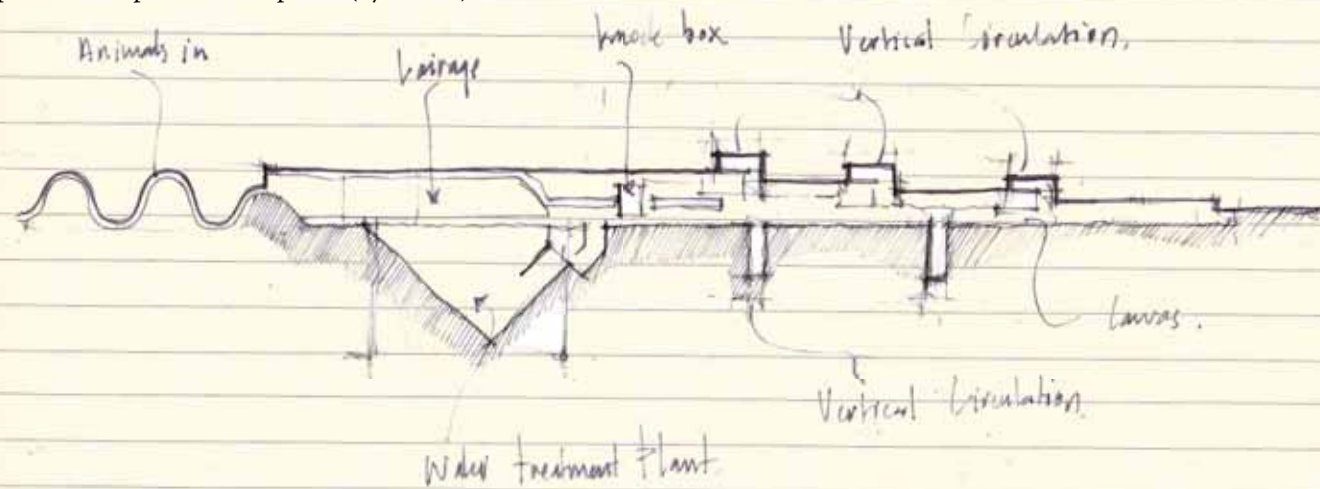

Figure - 8.25- Final conceptual sketch of lower ground floor plan / slaughter pit plan. The plan starts with the animals entering the pit via a Temple Grandin curved cattle chute. This leads the cattle to the lairage area, which is flank on the southern side by the waste water recycling plant. From here, they enter the CO2 knock box. After stunning, they never touch the pit floor again, only blood and viscera come into contact with the pit floor from there on (by Author).

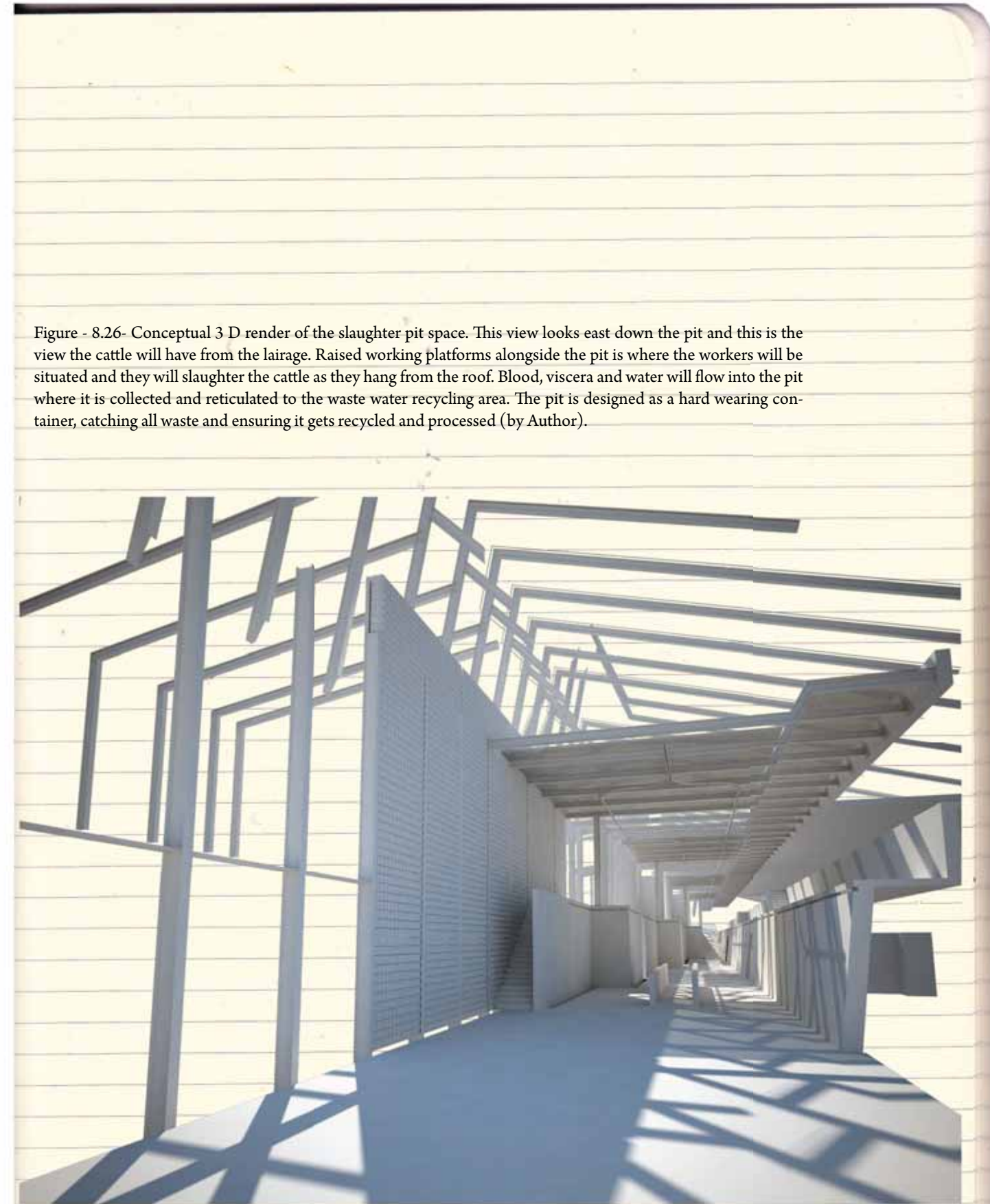

Figure - 8.26- Conceptual 3 D render of the slaughter pit space. This view looks east down the pit and this is the view the cattle will have from the lairage. Raised working platforms alongside the pit is where the workers will be situated and they will slaughter the cattle as they hang from the roof. Blood, viscera and water will flow into the pit where it is collected and reticulated to the waste water recycling area. The pit is designed as a hard wearing container, catching all waste and ensuring it gets recycled and processed (by Author).

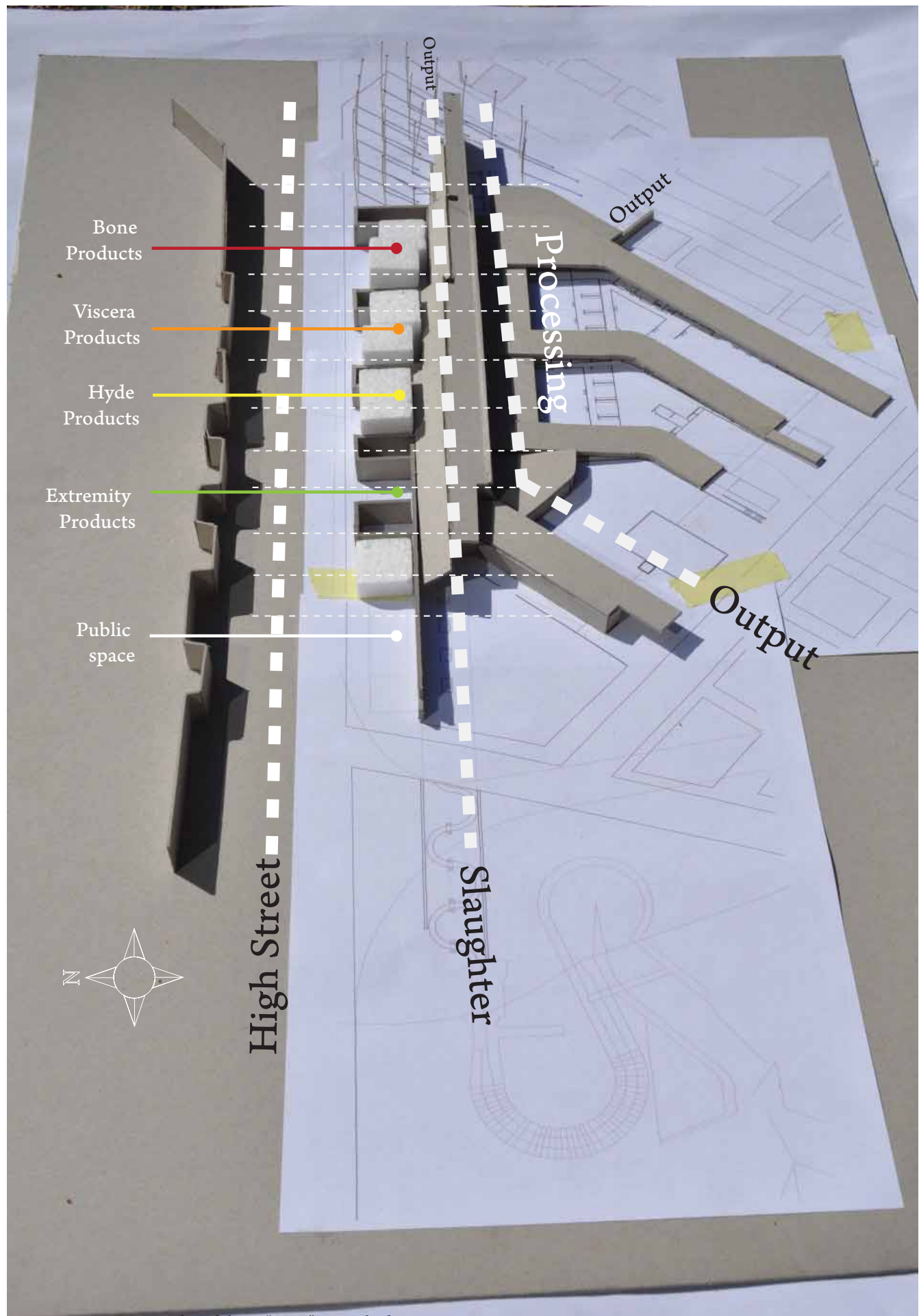

Figure - 8.26 - Conceptual model two "Form" - View looking east (By Author).

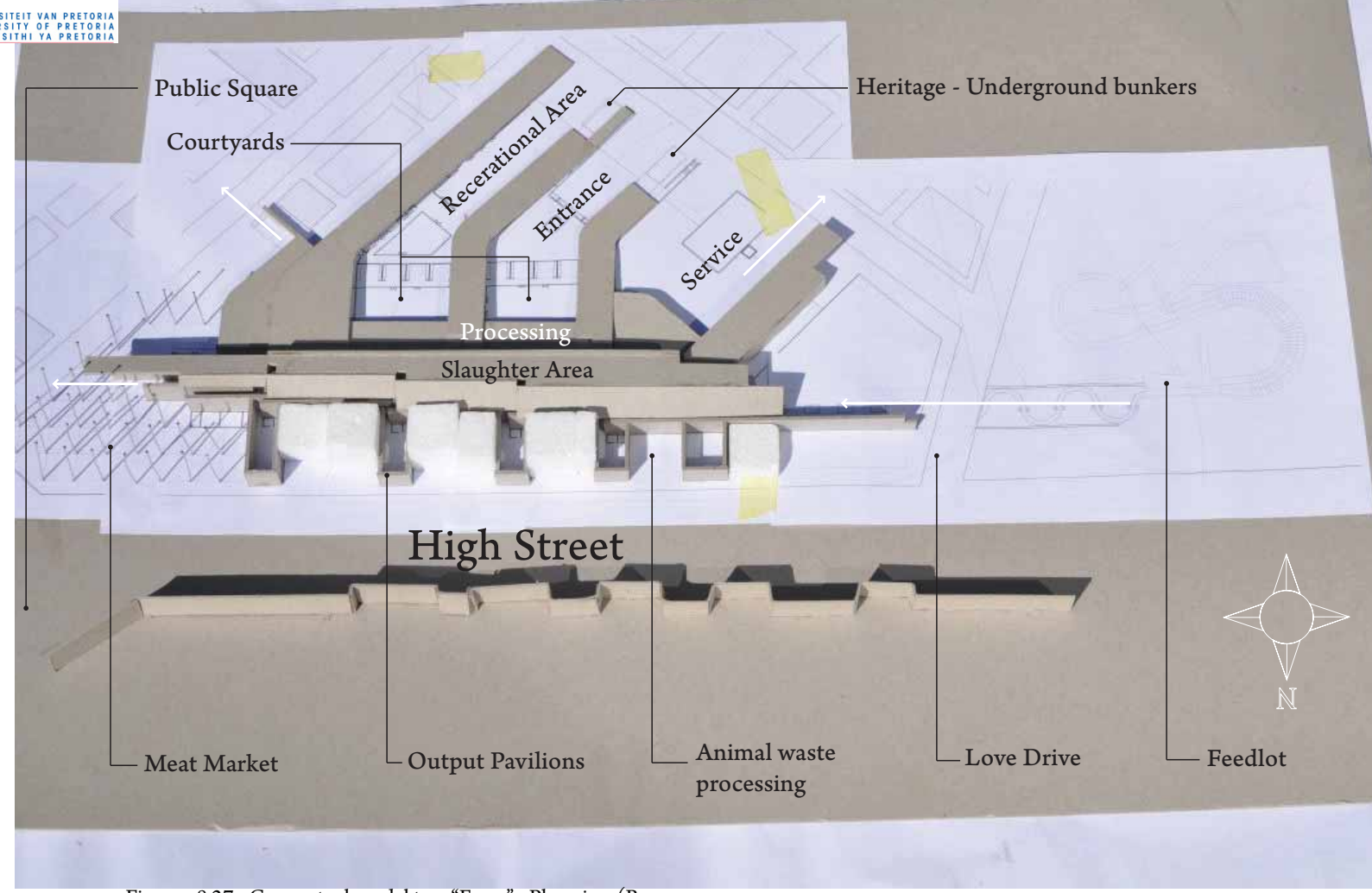

Figure - 8.27 - Conceptual model two "Form" - Plan view (By Author).

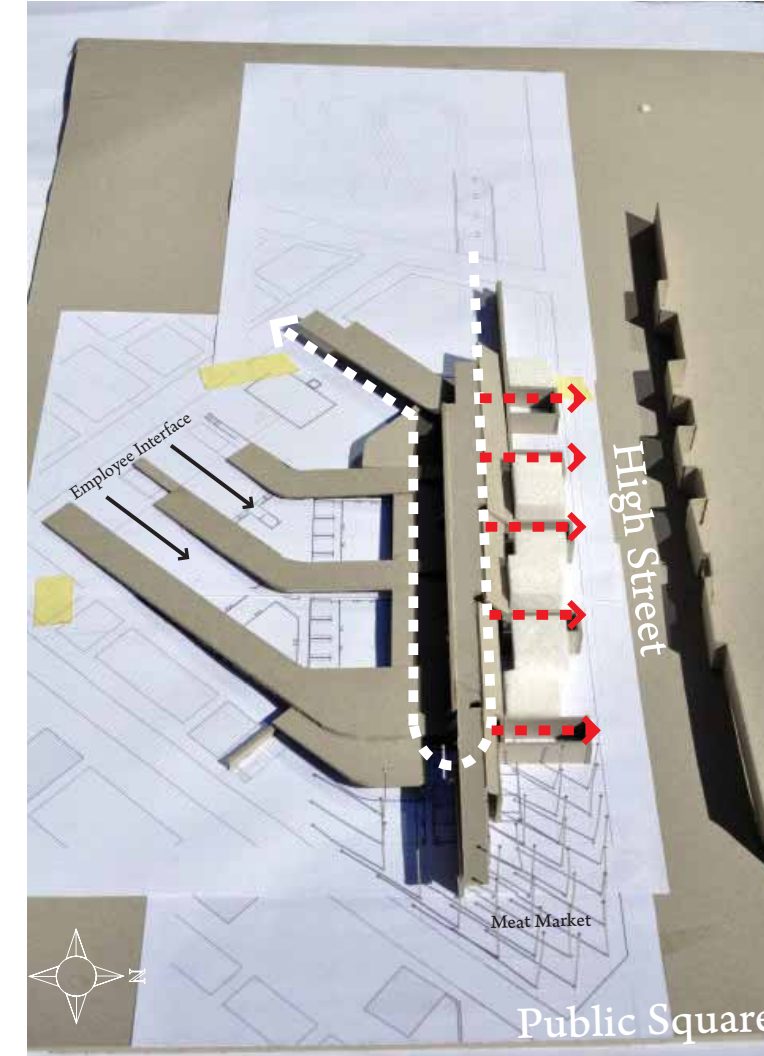

Figure - 8.28 - Conceptual model one "Form" - View looking west (By Author).

Public Square

SECTIONAL DEVELOPMENT

8.4

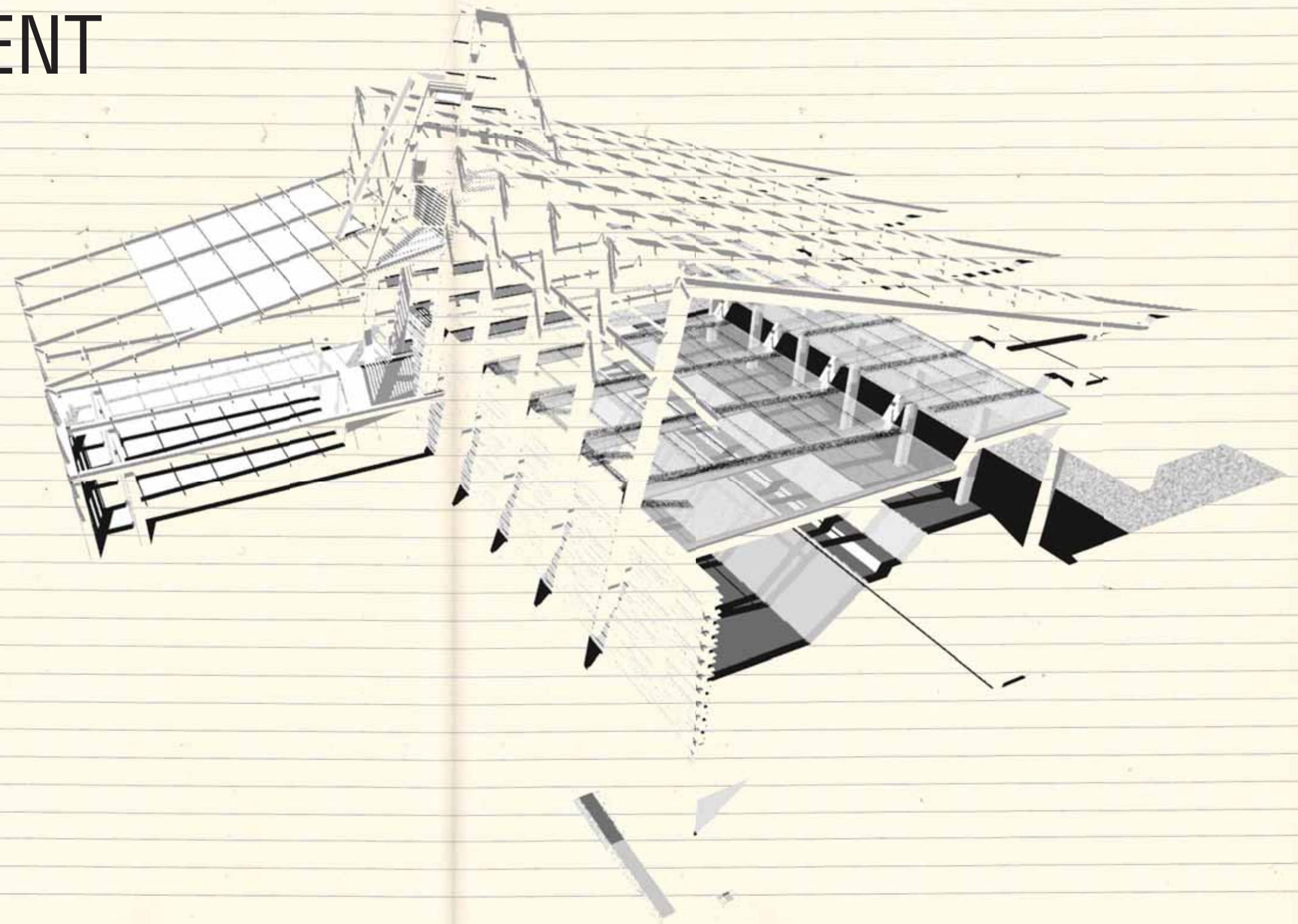

Figure - 8.29 - Conceptual render of 3 dimensional development of the tectonics of the structure (By Author).

PART 3: SECTION CONCEPT

The concept for the section was discovered after a visit to a local abattoir and witnessing the inner workings of such a space. As discussed in the precedent chapter (6.4) the three planes of architecture acquire different functions.

The concept was to design the sectional aspect of the building as to create these three planes and their respective functionality formally and tectonically distinctive. Secondly the sectional properties must respond to the site and its historical conditions such as the underground bunkers on the southern side which requires a response from the building. Thirdly the building has to respond to its high street condition in a layered fashion which was already discussed in the planning section of this chapter.

The sectional development utilises the output pavilions to achieve this layered facade.

Lastly the sectional properties of the building was informed by environmental considerations and to employ passive design principles. Cross ventilation, daylighting, heating and cooling were aspects considered in the design of the building. The passive systems were considered as to work in harmony with the mechanical systems.



Figure - 8.30 - Conceptual 3 dimensional render (By Author).



Figure - 8.31 - Early conceptual diagram (long section) depicting the recessed slaughter pit with the roof floating above (By Author).

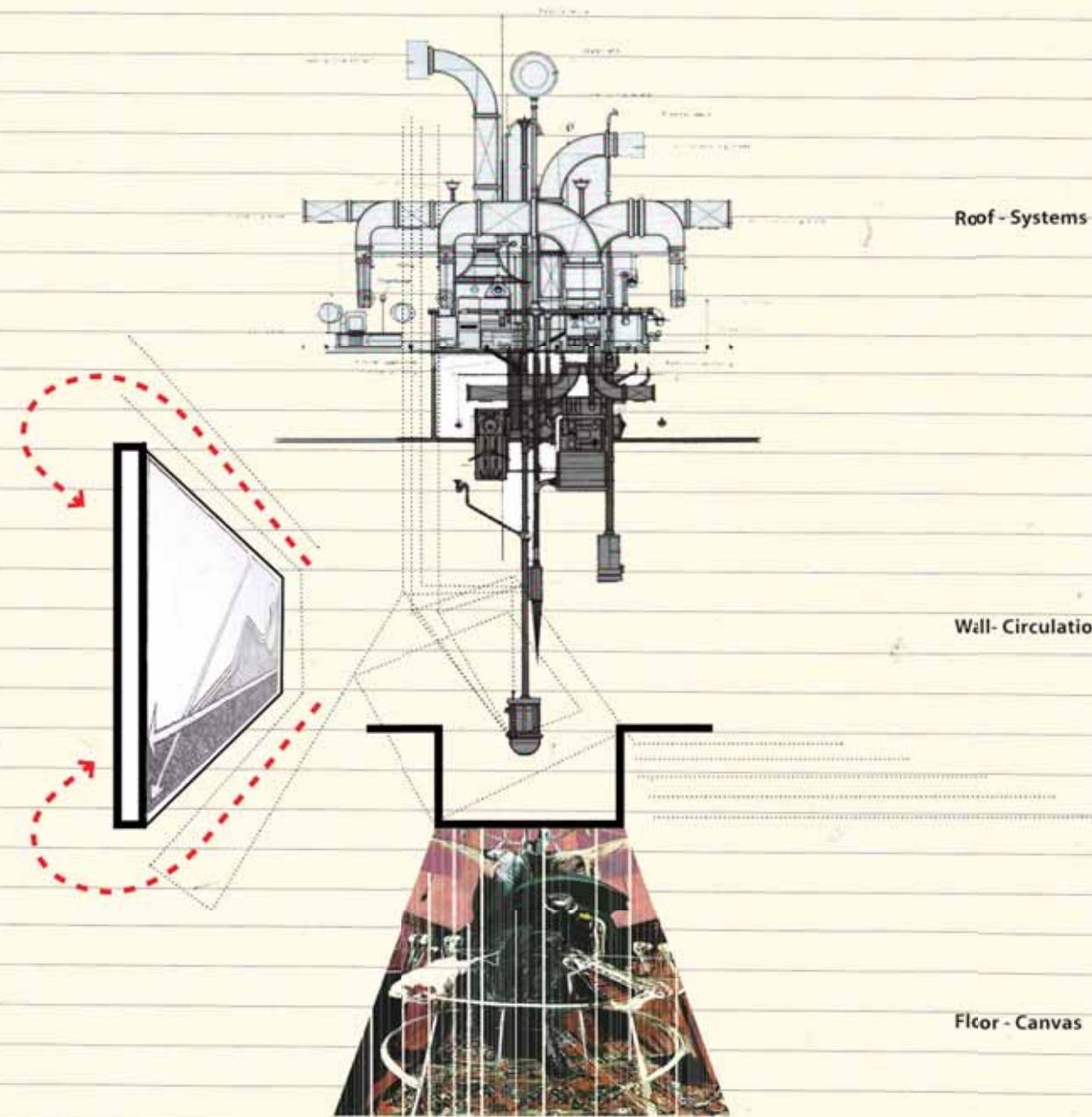

Figure - 8.32 - Section concept diagram depicting the three planes and their respective functions.

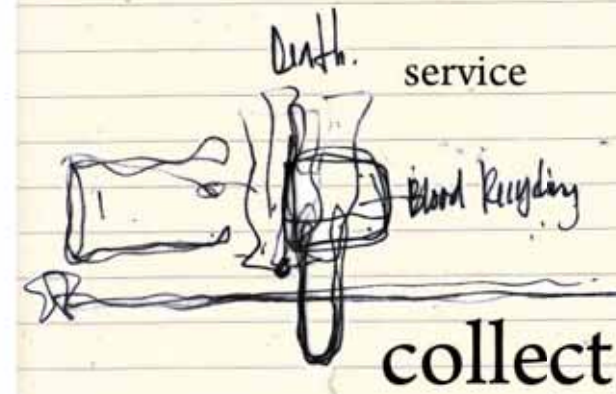
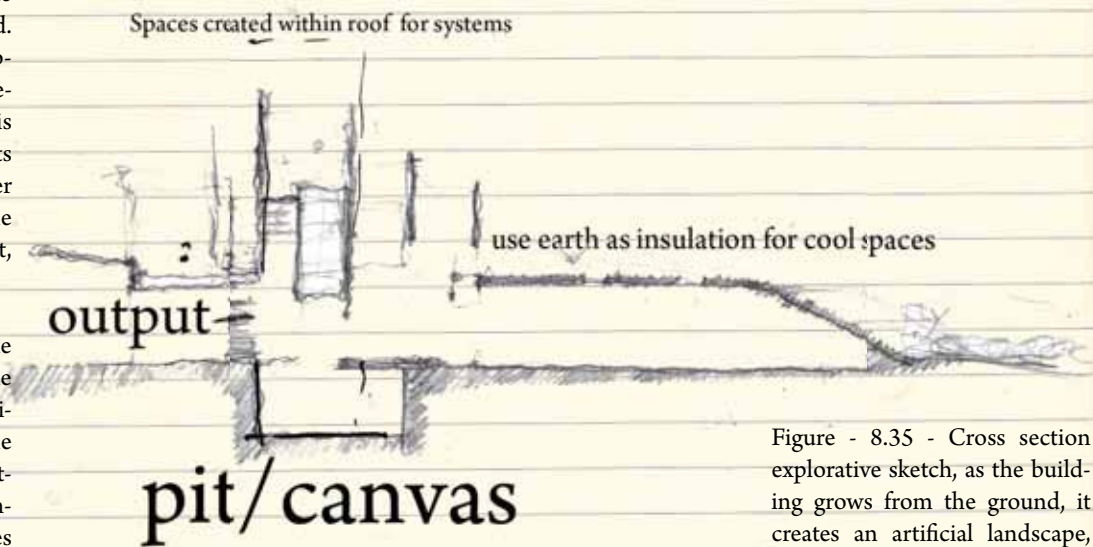

Figure - 8.33 - Cross section explorative sketch, a relationship between the floor and the roof is explored in function and in form. The roof is to engage with the public whilst acting as the central nervous system of the abattoir. The floor of the pit is to act as a canvas but also a channel, collecting all waste from animals as well as water. All waste is to be reticulated via the pit to an on site recycling plant (By Author).

Figure - 8.34 - Cross section explorative sketch, the roof as a space is explored. The output pavilion establishes a platform for engagement with the public. In this sketch, circulation elements were to form another layer to the facade, separating the public and the slaughter pit, spatially.



The decision to make the building grow out of the ground is made. The decision is two fold: connect the building to the buried heritage and provide adequate insulation for the large spaces which have to remain cool, by using the earth (By Author).

Figure - 8.35 - Cross section explorative sketch, as the building grows from the ground, it creates an artificial landscape, above which the roof is designed to float. The decision is taken to add vertical elements to the roof to visually anchor it, these elements are to become chimney stacks, to serve both mechanical and passive systems. The circulation element dividing the public and slaughter space is replaced by a wall over which the roof hangs, hinting towards what happens behind it.

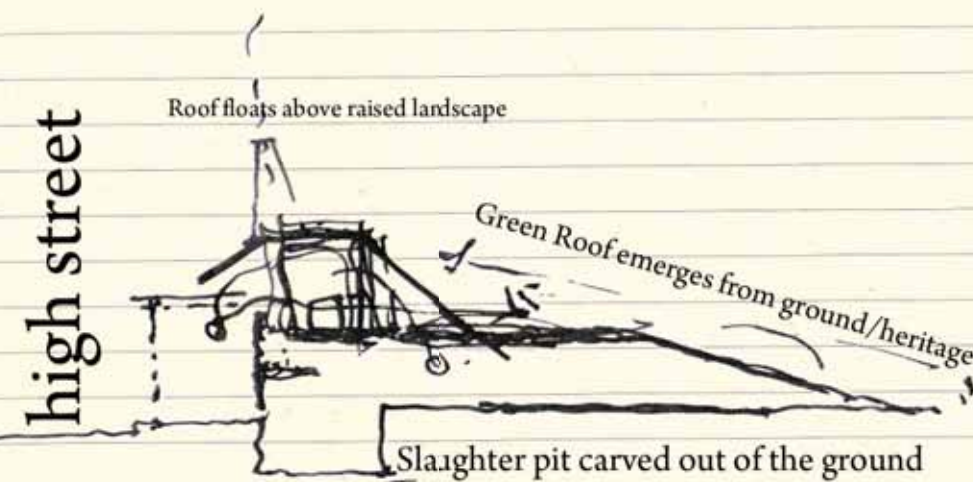

At this point a decision was made to devise a "typical section" model, which is to be applied across the linear slaughter area (By Author).

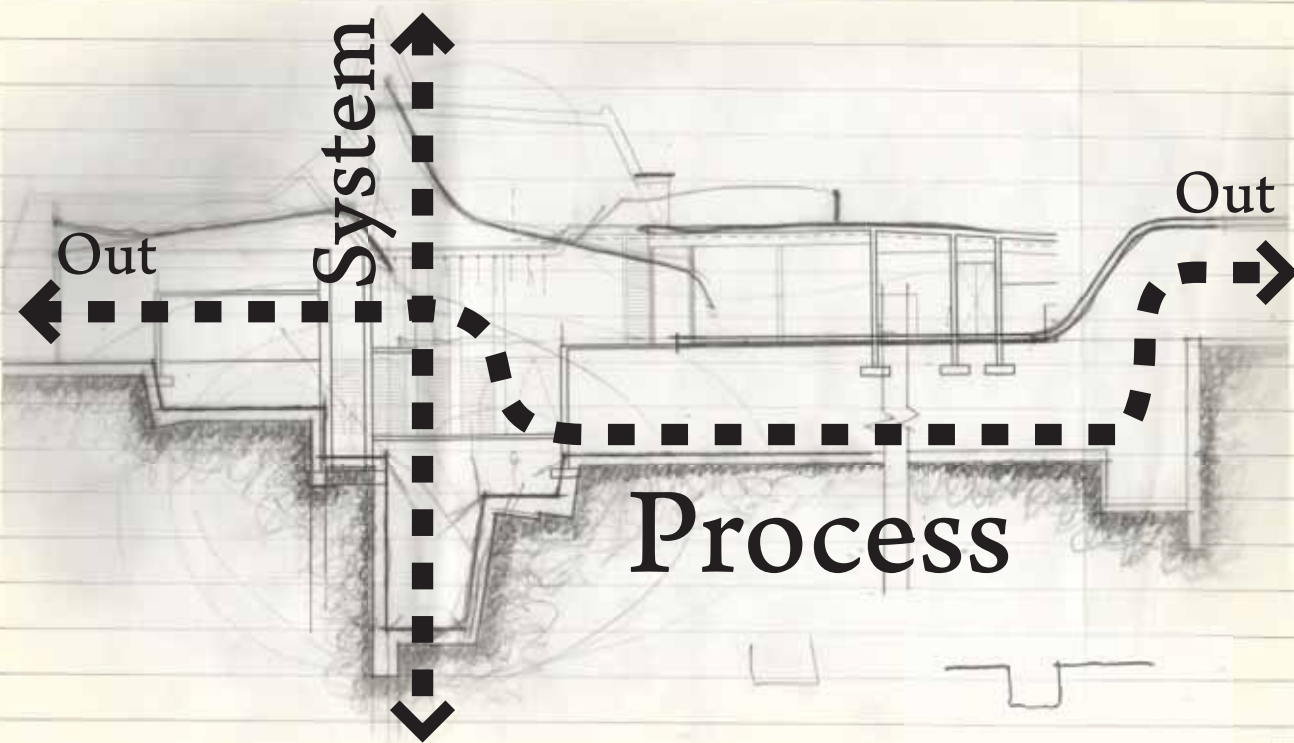

Figure - 8.36 - Further exploration of the building in section and the separation of levels. The "typical section" model is explored. This model is to be applied at the four output pavilions, where the main abattoir and the pavilion roofs meet. Furthermore, the slaughter process is explored on different levels (By Author).

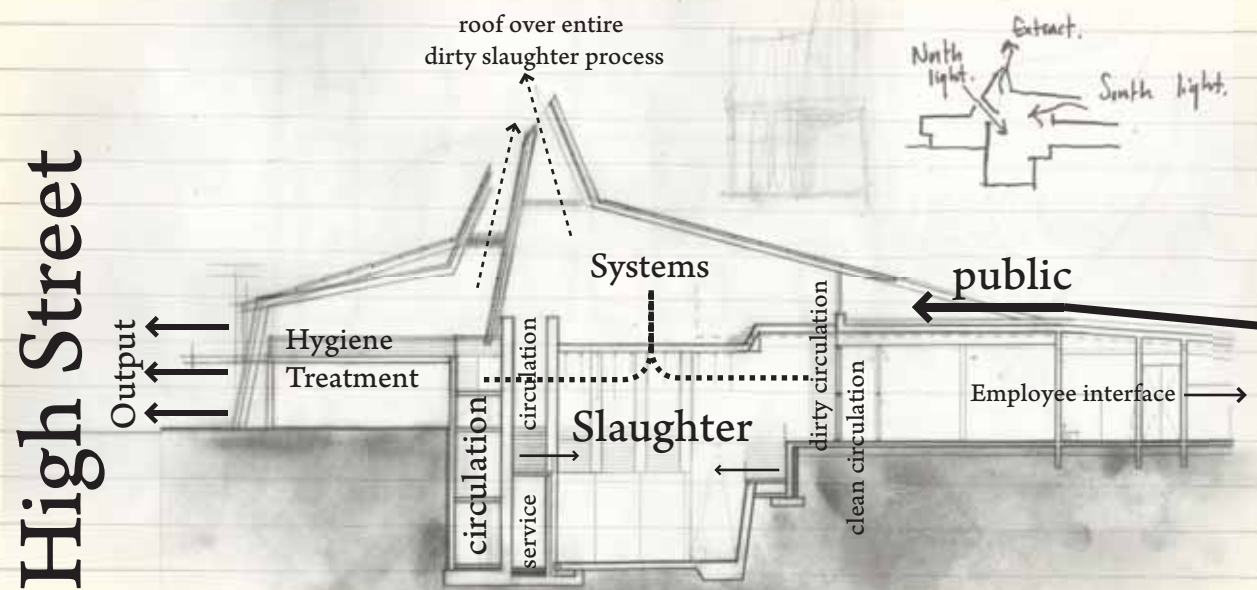

Figure - 8.37 - Further development - The two roofs are designed to meet within a combined chimney stack. The roofs are designed so that no warm or stale air can be trapped within the space. The roof funnels the warm air out to the chimney at the highest point. The roof space is defined by a floor which is added, the floor also denotes circulation beneath it by a step within the floor (By Author). The step also creates space for the services contained in the roof to be distributed to the rest of the building (By Author).

Figure - 8.38 - Typical cross section through slaughter pit beyond the output pavilion - This roof section was designed around cross ventilation and daylighting. The roof is perched on top of the wall, with windows separating it on both the northern and southern sides. This allows for ample daylighting and by making the windows operable, cross ventilation is possible. The air cooled over the grass on the roofs on the south, will move through the building, sucking the stale air out of the slaughter pit. This is achieved by using a steel mesh floor which allows the entire roof and pit space to be vented (By Author).

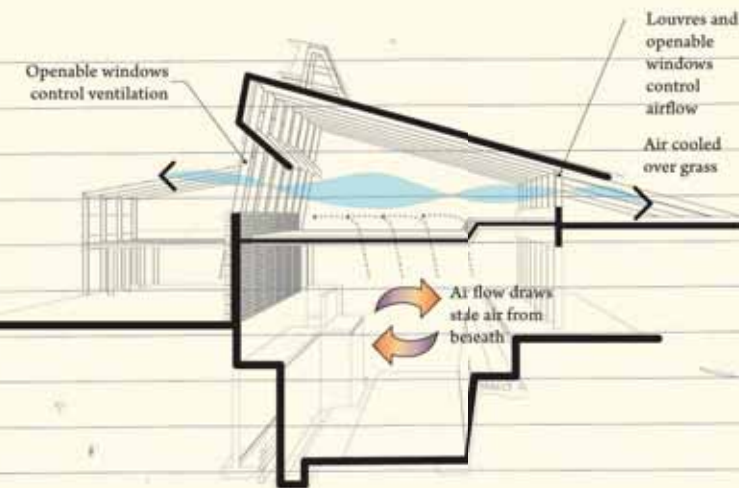

Figure - 8.39 - Light explored on section. The north facing windows are to be designed with a large window head which makes the roof appear as if it returns on itself. This is to exclude sun travelling to deep into the pit and creating uncomfortable condition for the workers. The sun is only to illuminate the pit itself. By lifting the roof on the southern side constant south light can provide illumination to the roof and slaughter space (By Author).

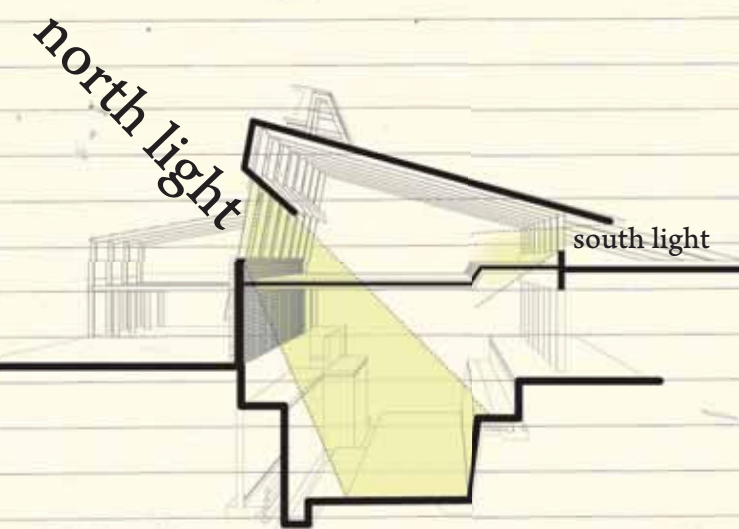
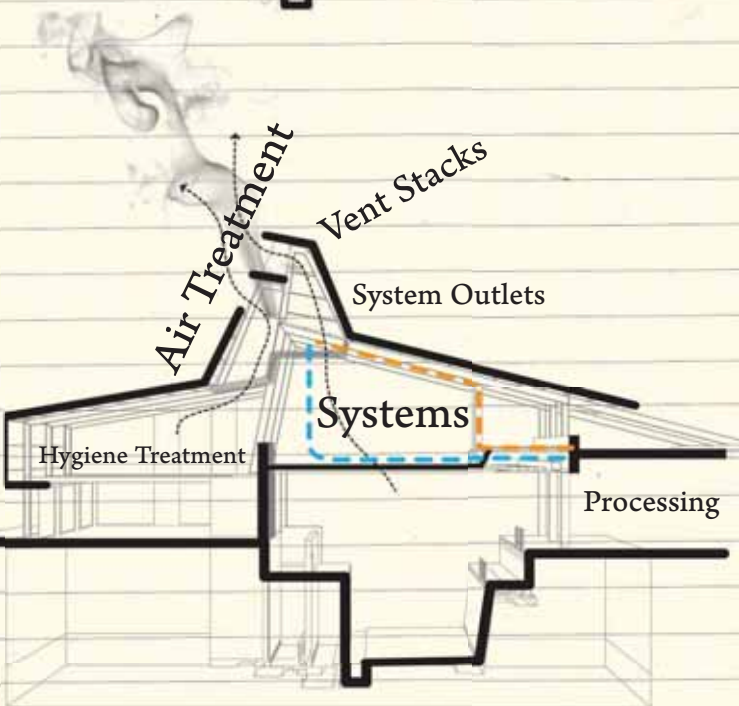

Figure - 8.40 - Section through chimney stack part of roof. This model is to be repeated four times throughout the building, with the section shown in fig. 8.35 to connect these elements.



These stacks are to work passively and actively. Warm stale air can continuously flow out through the stacks, whilst systems such as an air scrubbing system, condensers of the air conditioning and refrigeration systems and the extraction system will be situated within them. The systems located in the roof will plug into the processing spaces situated underneath the green roofs, which fall and disappear into the ground (By Author)

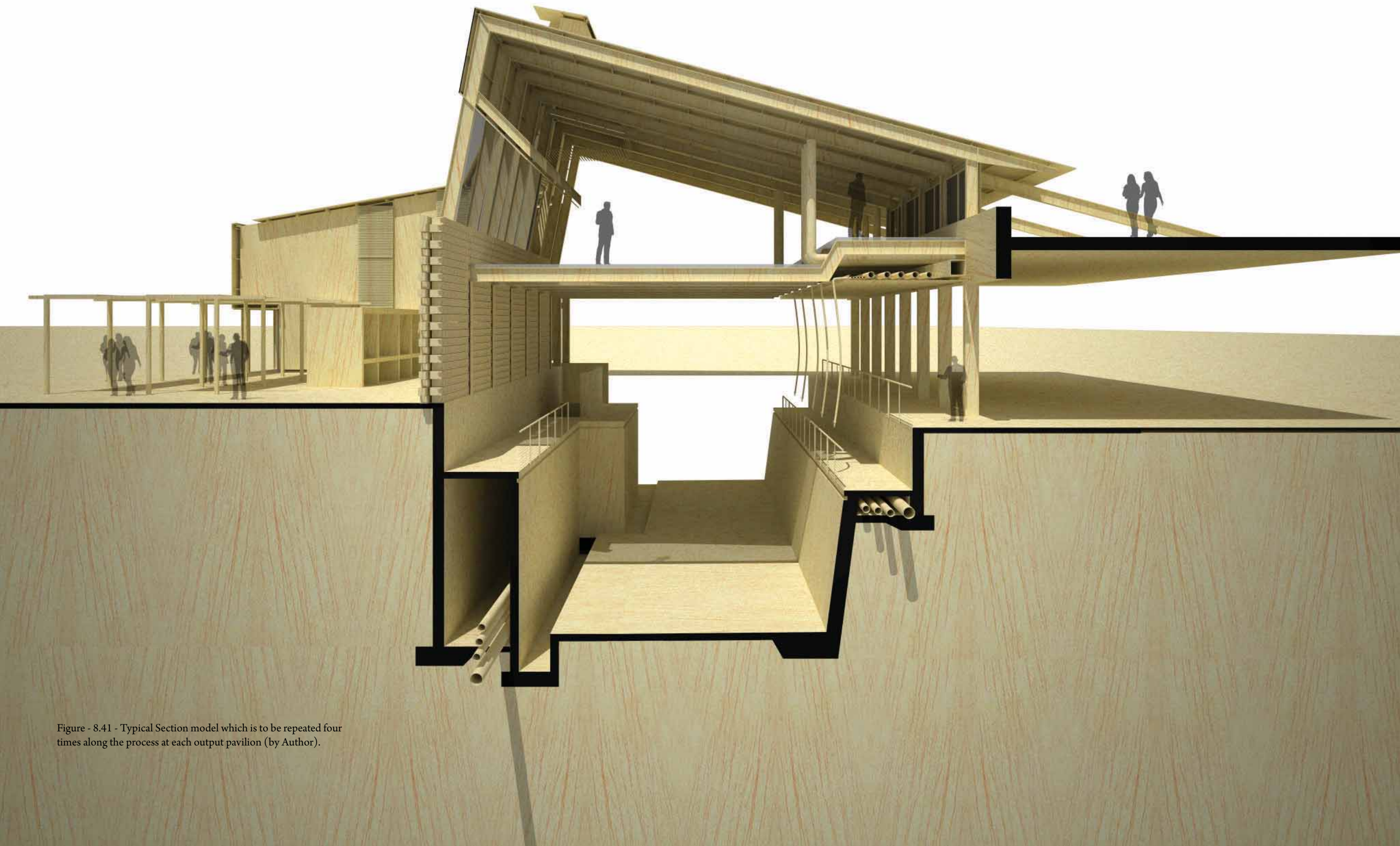

Figure - 8.41 - Typical Section model which is to be repeated four times along the process at each output pavilion (by Author).

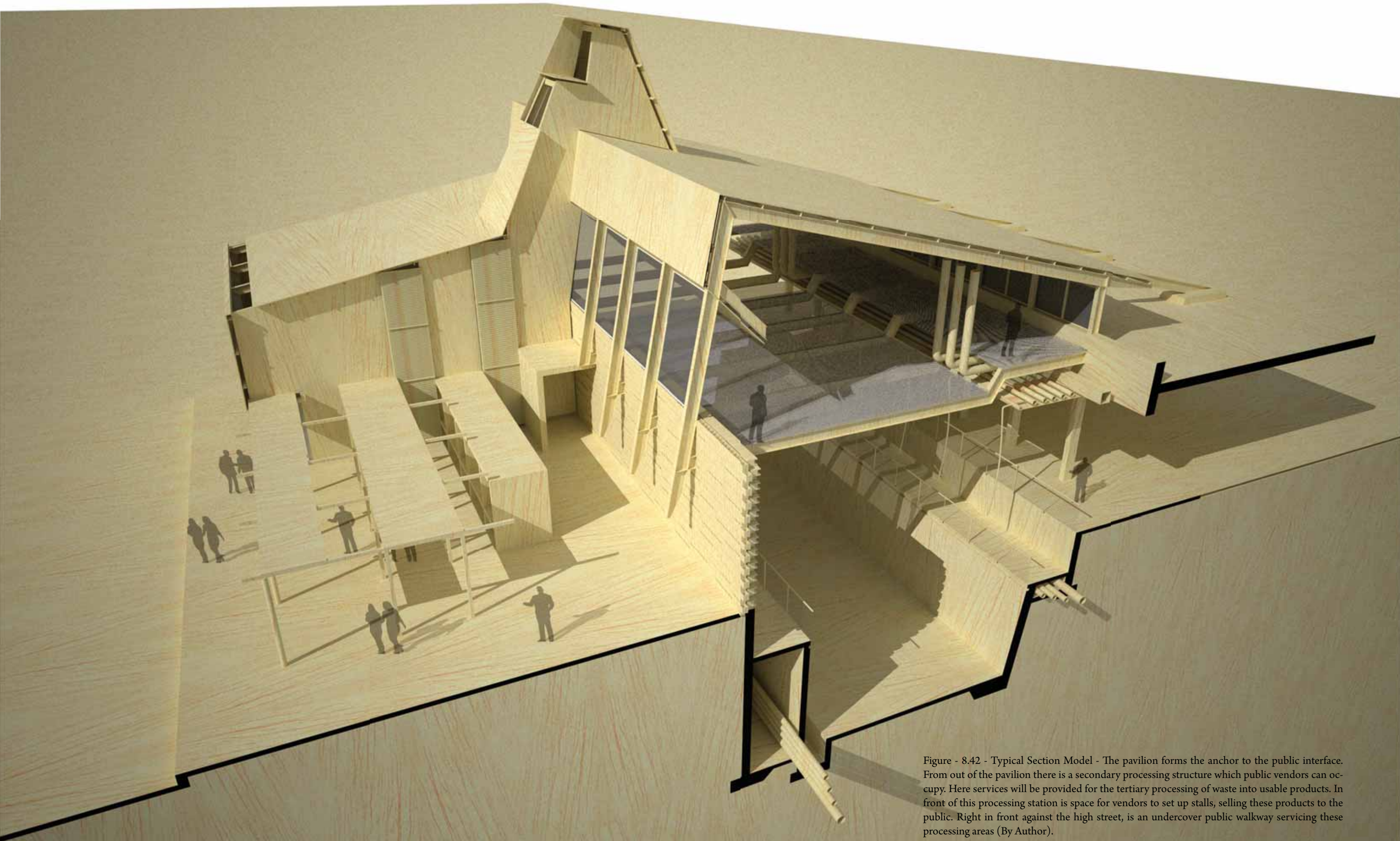

Figure - 8.42 - Typical Section Model - The pavilion forms the anchor to the public interface. From out of the pavilion there is a secondary processing structure which public vendors can occupy. Here services will be provided for the tertiary processing of waste into usable products. In front of this processing station is space for vendors to set up stalls, selling these products to the public. Right in front against the high street, is an undercover public walkway servicing these processing areas (By Author).

REGENERATIVE DESIGN APPLICATION

The following outlines how the Hannover regenerative principles influenced the design decisions and final product.

1

Insist on rights of humanity and nature to coexist

Response: The abattoir plants itself within the public realm in a constructive manner. It attempts not to deter any public activity around it and provides facilities to amplify such activities. The building functions at such a sustainable level that it acts as a positive power plant supplying itself with energy where possible. The process housed, although industrialised, is natural and unavoidable and the placement of the building reunites the consumer with the product. In this case, it attempts to close the hyper separated state between the animals and the people who consume them.

2

Recognise interdependence

Response: The abattoir depends on the natural and man made elements around it. It requires the people to make use of its facilities, whilst also providing a foothold for the entire area to develop. Its placement encourages the connection of separated communities and provides these communities with common ground, employment and economic venture.

3

Respect relationships between spirit and matter

Response: The abattoir serves its surrounding communities directly and indirectly through supporting a series of small business incubators scattered across the development. It encourages trade and economic development and is based on the ritual slaughter methodology of reclaiming the entire animal and respecting/ acknowledging the animal. In striving for economic progress the building addresses the animal and the communities spiritual connection to it with civility.

4

Accept responsibility for the consequences of design decisions

Response: The dissertation focuses on the coexistence of industry within the public realm, mediated through regenerative and sustainable principles. The aim of the design is to achieve a symbiosis between industry, society and nature, by providing a new interface based on heritage, recycling / ritual and economic progress.

5

Create safe objects of long-term value

Response: The abattoir is the heart of the new development. By incorporating a feedlot into the scheme, the abattoir will have constant business due to its preferred location to its consumers. The building incorporates numerous technologies which make it safe to operate within the public realm. These systems process waste into usable products and even by-products which can support the peri urban agriculture (high nutrient slurry from bio gas digester can be used as compost), which happens within the area. The building taps into the existing community network with a constant supply of numerous products.

6

Eliminate the concept of waste

Response: Abattoirs produce large amounts of waste. Waste forms the most important cog in the design of the new abattoir. Not only does it provide the connection to rituals but also provides economic opportunities surrounding it that are exploited. The building functions on a zero-waste concept and finds functional use for all types of waste.

7

Rely on natural energy flows

Response: Natural energy flows are incorporated into the design to relieve the stress on exhaustive mechanical systems. Passive design principles are incorporated throughout the building in the form of ventilation, insulation, heat gain and loss and solar energy. Energy is also produced from organic waste, further emphasising natural energy flows.







8

Understand the limitations of design

Response: The design does not attempt to solve all the inherent problems in Mamelodi or solve all the social-ills concerning animal slaughter. The building aims to provide a sustainable foothold for future development and addresses possibilities of production within densely populated areas. The abattoir does not aim to turn people into vegetarians nor increase meat consumption, it strives to create a public discourse which can start to break down society and nature's hyper separated state.

FINAL LAYOUT

Basement Plan - Key

-  Slaughter Pit
-  Cattle shute and lairage
-  General Circulation
-  Water Treatment Plan
-  Service areas
-  CO₂ Stun Box

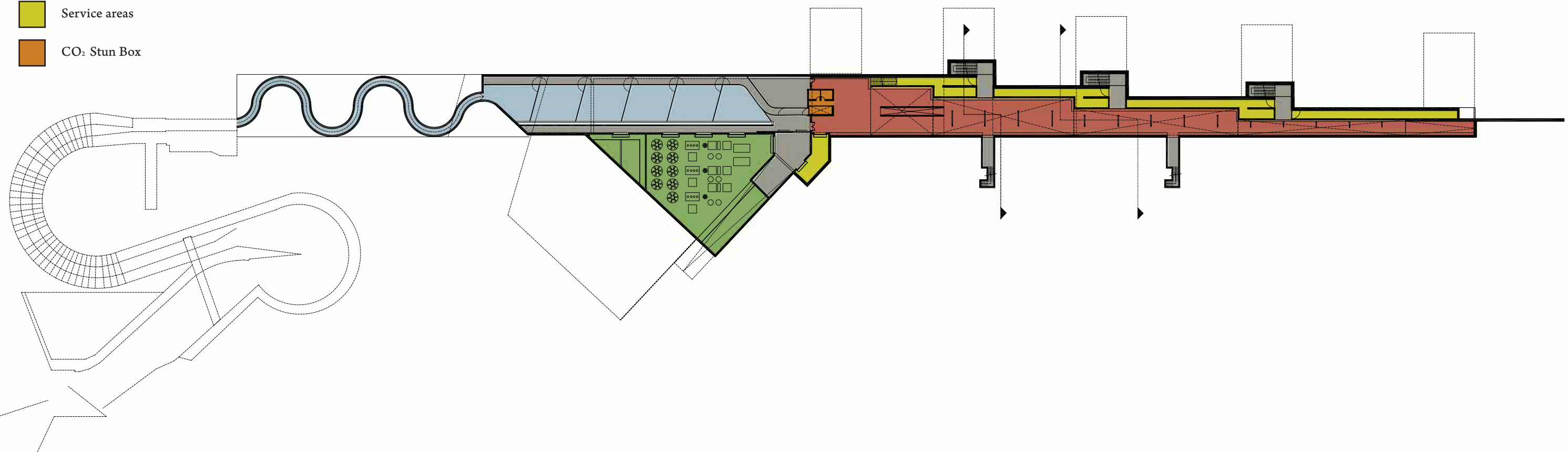
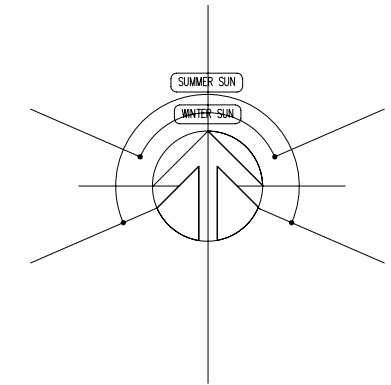
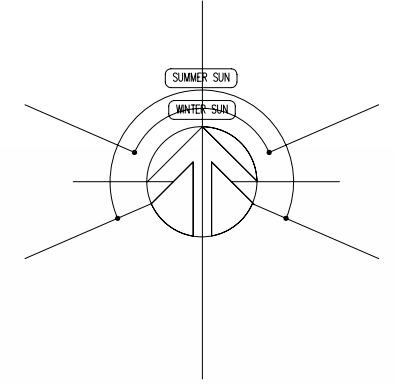

Figure - 8.43 - Basement Plan (By Author).

Ground Floor Plan



- Slaughter Process
- Processing Spaces
- Primary Circulation
- Service Spaces
- Ablution
- Labs
- Freezers
- Offices
- Recreational spaces
- Dispatch Area
- Educational/ Conference Space
- Cafeteria

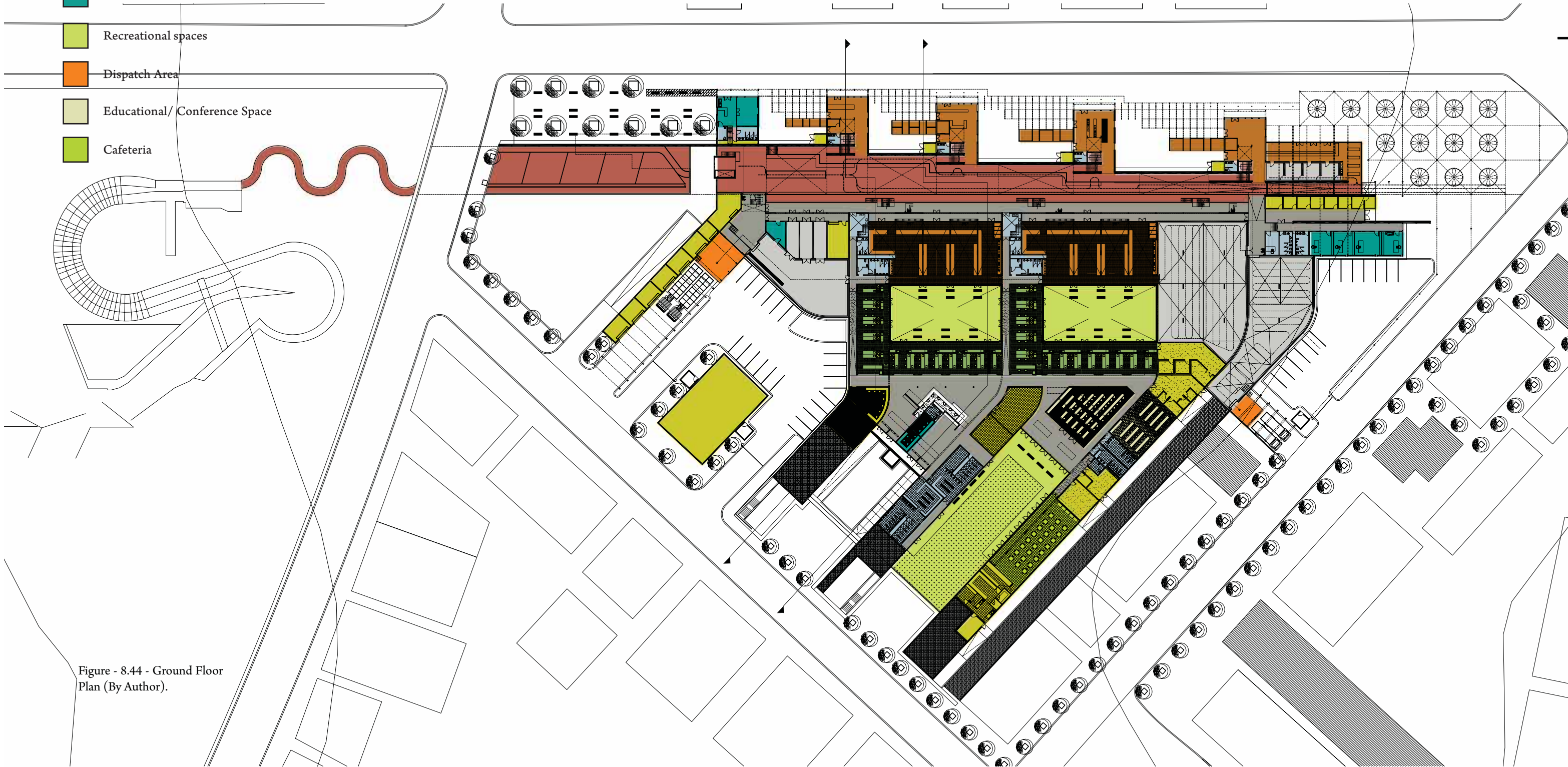

Figure - 8.44 - Ground Floor Plan (By Author).

Service Floor Plan - Key

- CO₂ Stunning
- Processing Spaces
- Primary Circulation
- Service Spaces
- Offices
- Recreational spaces

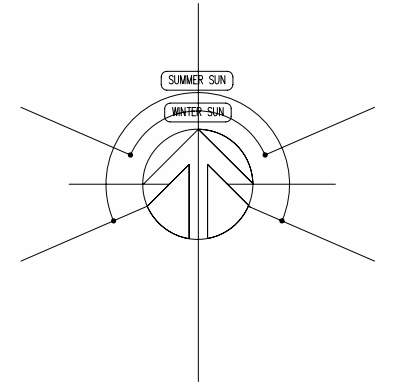

Figure - 8.45 - Service Floor Plan (By Author).



Figure - 8.46 - Early 3D image of the building, view looking north. The building grows from the southern edge with the roof floating above the new ground plane (By Author).

Figure - 8.47 - Above - 3D of high street with the repetitive pavilion model. The public spaces in between start to develop (By Author).

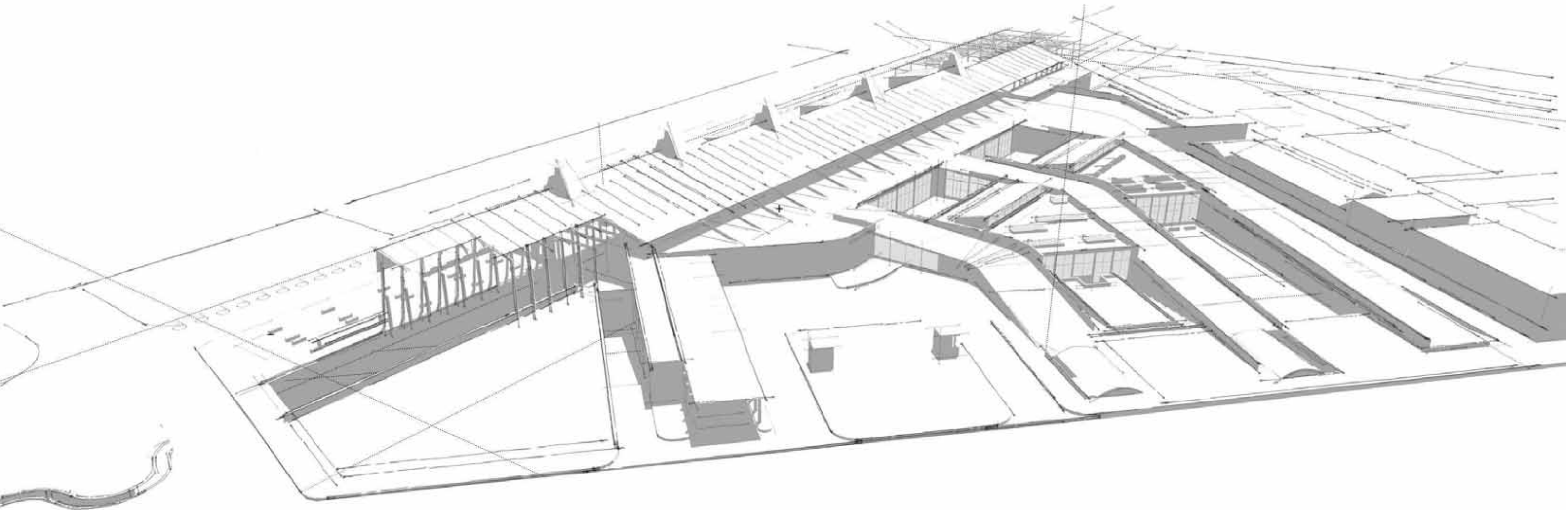

Figure - 8.48 - 3D view from above depicting the entire building form and its connections to all the edges of the site (By Author).

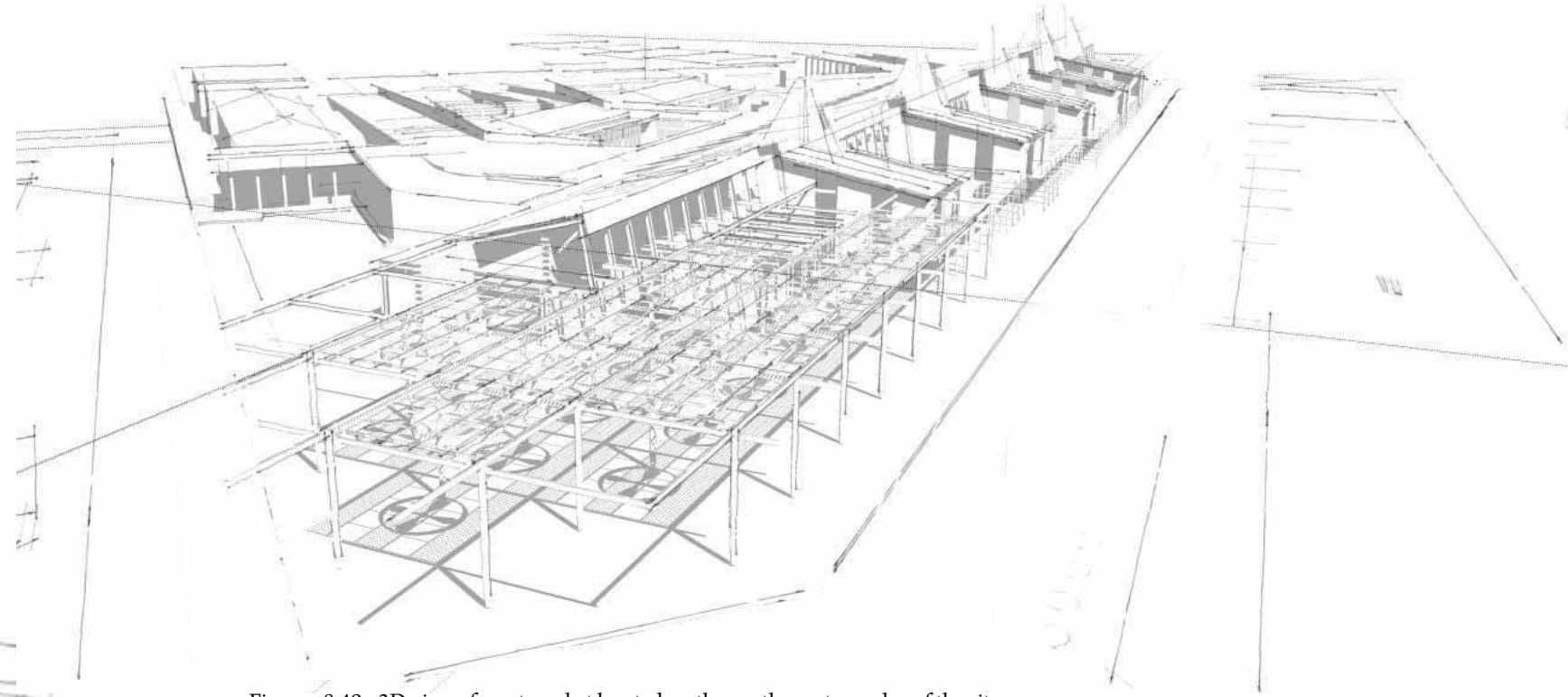
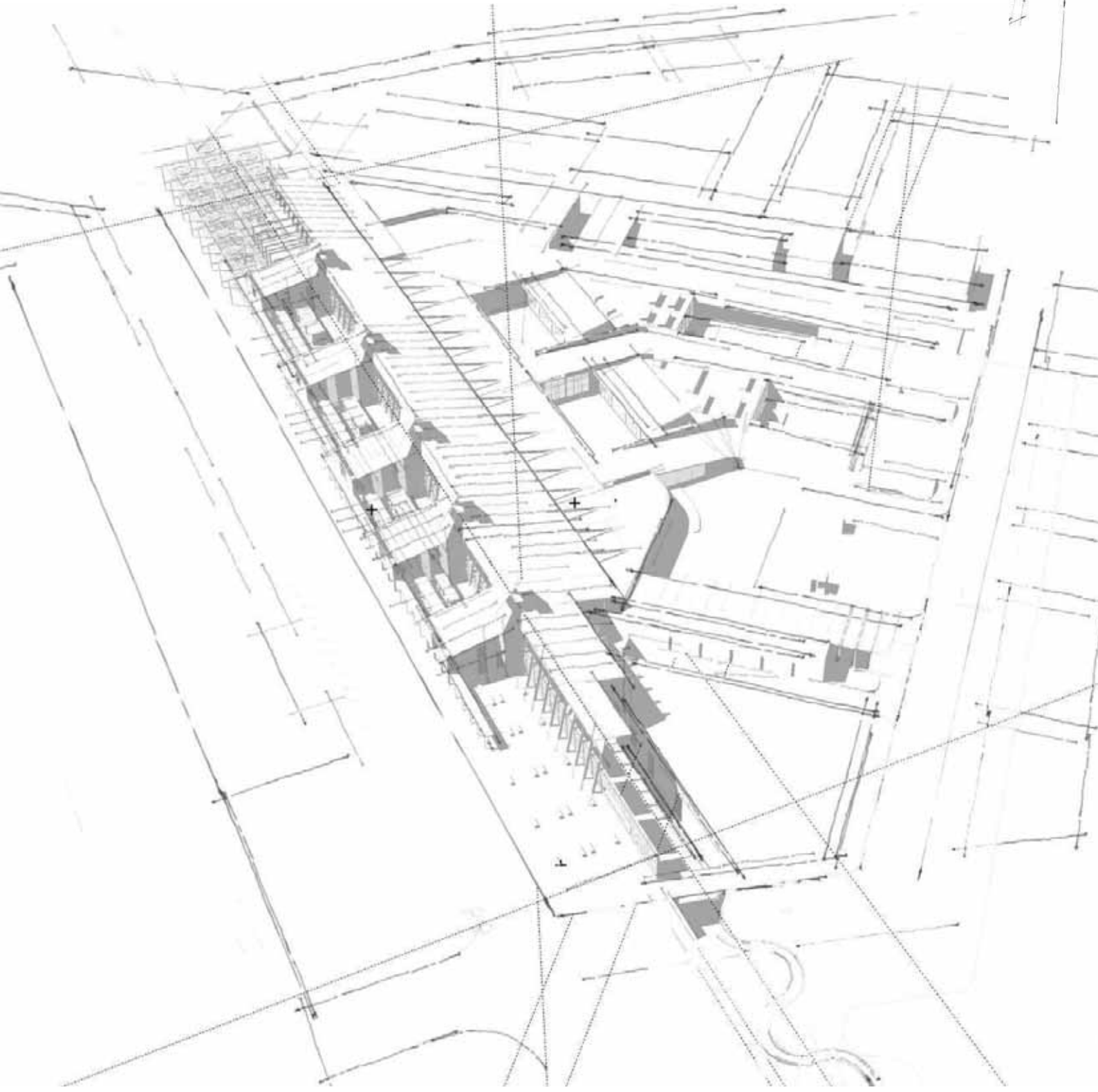

Figure - 8.49 - 3D view of meat market located on the north - eastern edge of the site.



Figure - 8.50 - Close up 3D view of the processing pavilions (By Author).



The technical investigation is discussed under four headings namely:

Stereotomy
Techtonic - The Frame and the Skin Systems

These four headings cover all aspects of the structural, technological and design decisions made when the repetitive module shown in Fig 8.42 was designed.

Figure - 9.1 - Photograph of the roof in Rietvlei Abattoir depicting the amount of structure and technology housed in it (By Author).

TECHNICAL INVESTIGATION

Stereotomy - The Slaughter Pit

The pit, as discussed in the design development chapter (8), is recessed into the ground to relate to the existing heritage, and to create a insulated condition under which the pit can stay cool without excessive mechanical cooling.

The pit is constructed from a concrete retaining structure, which is moulded to create working platforms, circulation and the canvas. The next concept was to integrate the pit into the ground. A decision was made to not tank the basement in the traditional manner, which allows no water in. The design explored manners in which the ground water can enter the building allowing the canvas plane, the bottom plane of the pit (Fig 9.4), to be in a constant active state. This resulted in the following technological decisions to be made.

Ferrule Holes

The ferrule holes in the diagonal pit wall is left open, with a root barrier and prefilter layer (Fig 9.3) the ground water is allowed to push through, run down the wall, and start to wash the blood from the pit floor. This allows the pit floor to be in constant flux, creating a ebb and flow of water and blood.

Retaining walls

On the northern edge the pit is constructed of a vertical concrete retaining wall. The wall is not tanked and employes a drained cavity with a geotextile/ rootbarrier and pre-filter layer

(Fig 9.5). The entering water runs underneath the floor, through a raised precast concrete floor channel system, and into the drainage channel from where it is pumped to the water treatment plant. The drainage channel is divided in two, separating the groundwater from the contaminated water.

Drains

Drains from the processing areas are laid to fall through the service duct shown in Fig 9.3, which allows even more water to enter the pit area. The water from here will mostly consist of water used to clean the processing floors, contaminated with blood and soap.

Recycling

All the contaminated water entering the pit runs of the sloped pit floor into a drainage channel from where the contaminated water is pumped to the water treatment plant.

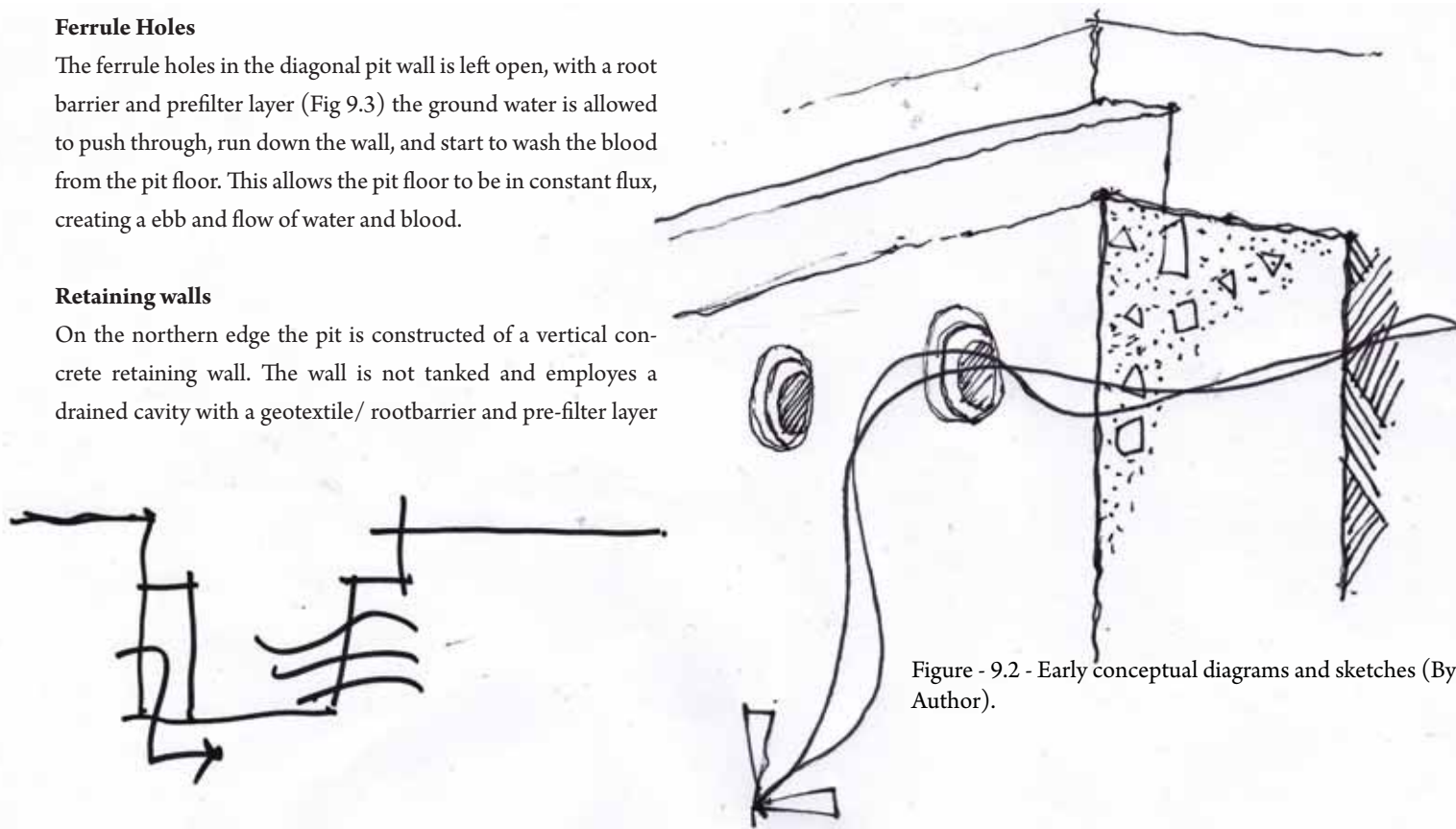

Figure - 9.2 - Early conceptual diagrams and sketches (By Author).

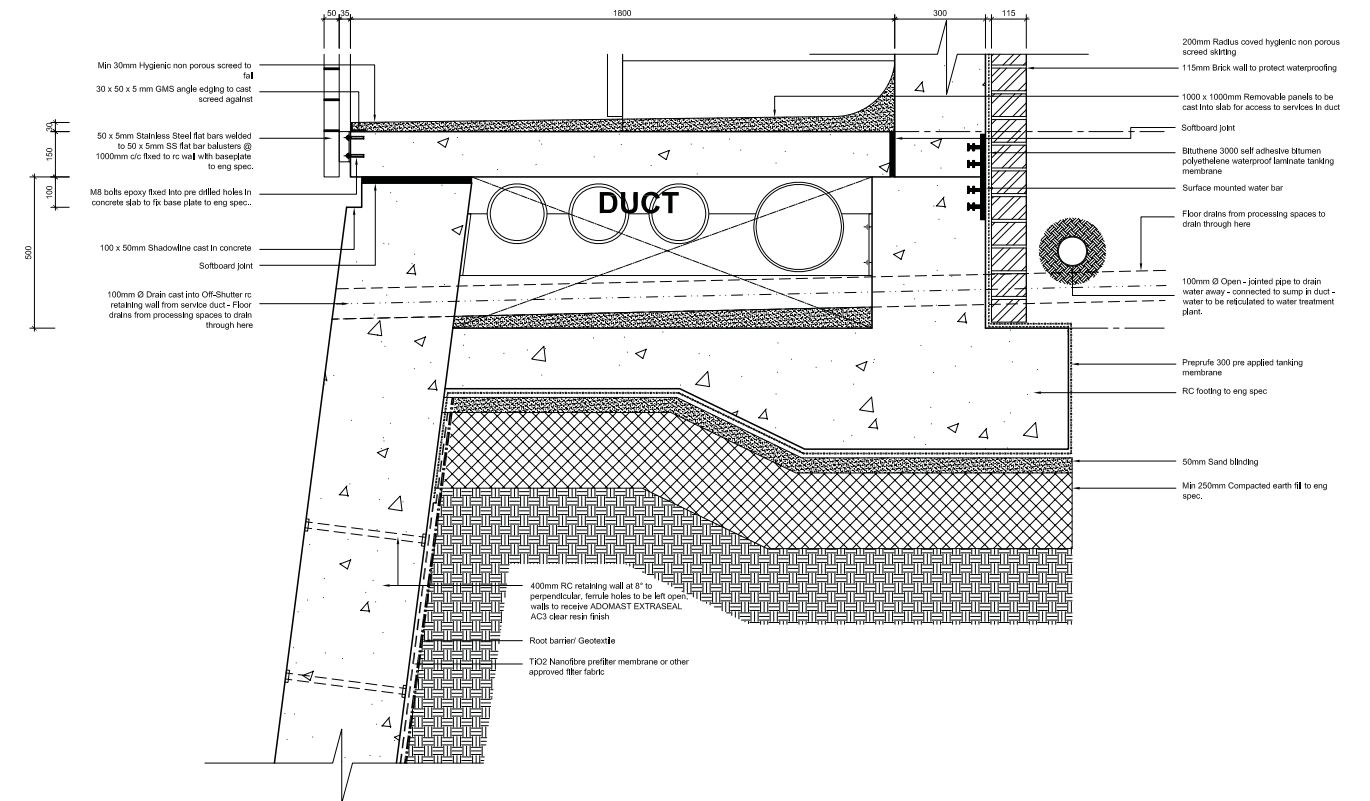
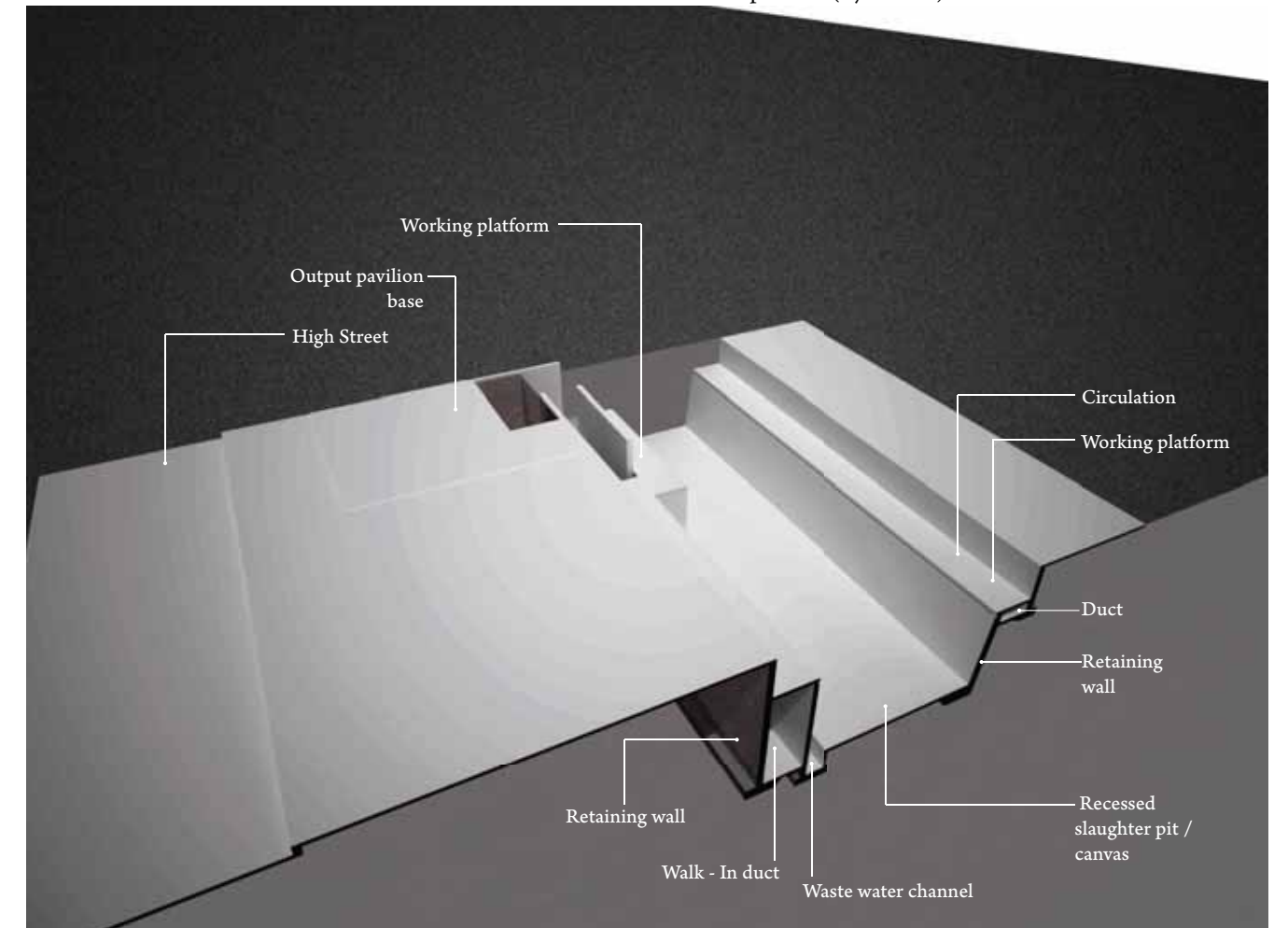

Figure - 9.3 - Above - Detail of work platform and the pit wall, illustrating the detailing around water entering the structure (By Author).

Figure - 9.4 - Below - 3D section render of the slaughter pit and its components (By Author).



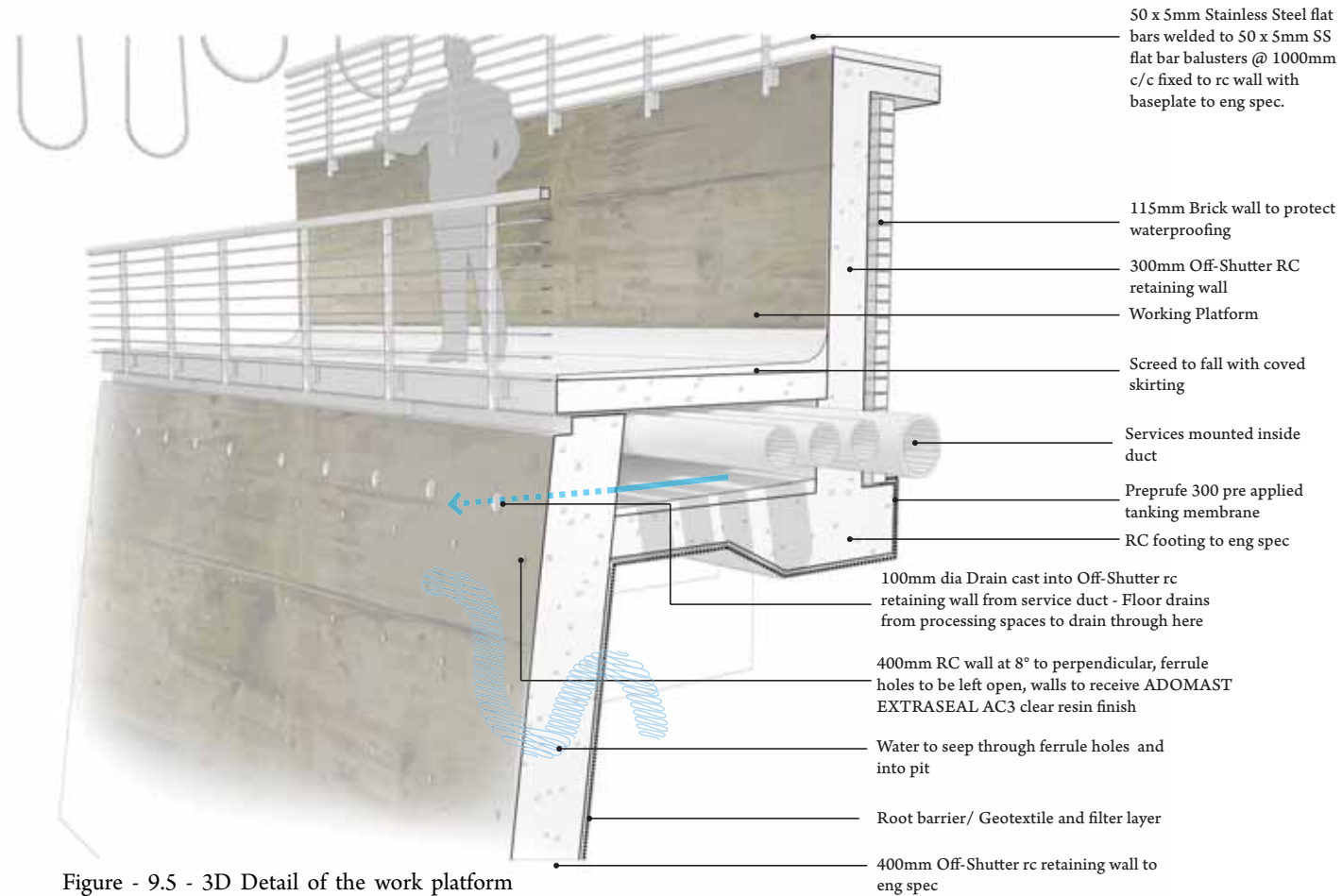

Figure - 9.5 - 3D Detail of the work platform showing the pit, its components and how the water enters (By Author).

The Processing and Circulation Spaces

These spaces are covered by three ramps, which grow out of the ground from the southern edge of the site. The ramps and its supporting structure consists of Off-Shutter concrete. The ramps connect to the flat concrete roof over the processing areas, which in turn connects to the slaughter pit. Sustainable concrete technology was researched to counter the environmental effects of the amount of concrete being used.

The TX Active range of cements developed by ESSROC (North American company) was selected based on its innovative approaches to sustainable concrete practice. The product identified is the photocatalytic cement product called TX Aria. Some facts concerning this cement product as listed by the company on www.essroc.com:

The TX Aria is a self cleaning and pollution reducing concrete consisting of a photocatalytic cement mixture.

Photocatalysis

A natural phenomenon in which a substance, the photocatalytic principle, utilizes light to alter the speed of a chemical reaction. By taking advantage of the energy of light, the principle will accelerate the formation of strong oxidizing reagents which will result in the decomposition of organic and inorganic pollutants. These pollutants are responsible for gathering on the surface of concrete causing discolouration, as well as, many health related issues. Photocatalysis is an accelerator of an oxidation process that already exists in nature. It promotes faster decomposition of pollutants and prevents them from accumulating.

Admixtures

Further investigation was done into the sustainable placing of concrete. Admixtures were investigated and CAEXOL air entraining admixture reducing water required and increasing durability, and BASF Rheomix® 630 S plasteciser further reducing water required for mixing and increasing the production rate was incorporated into the concrete structure.

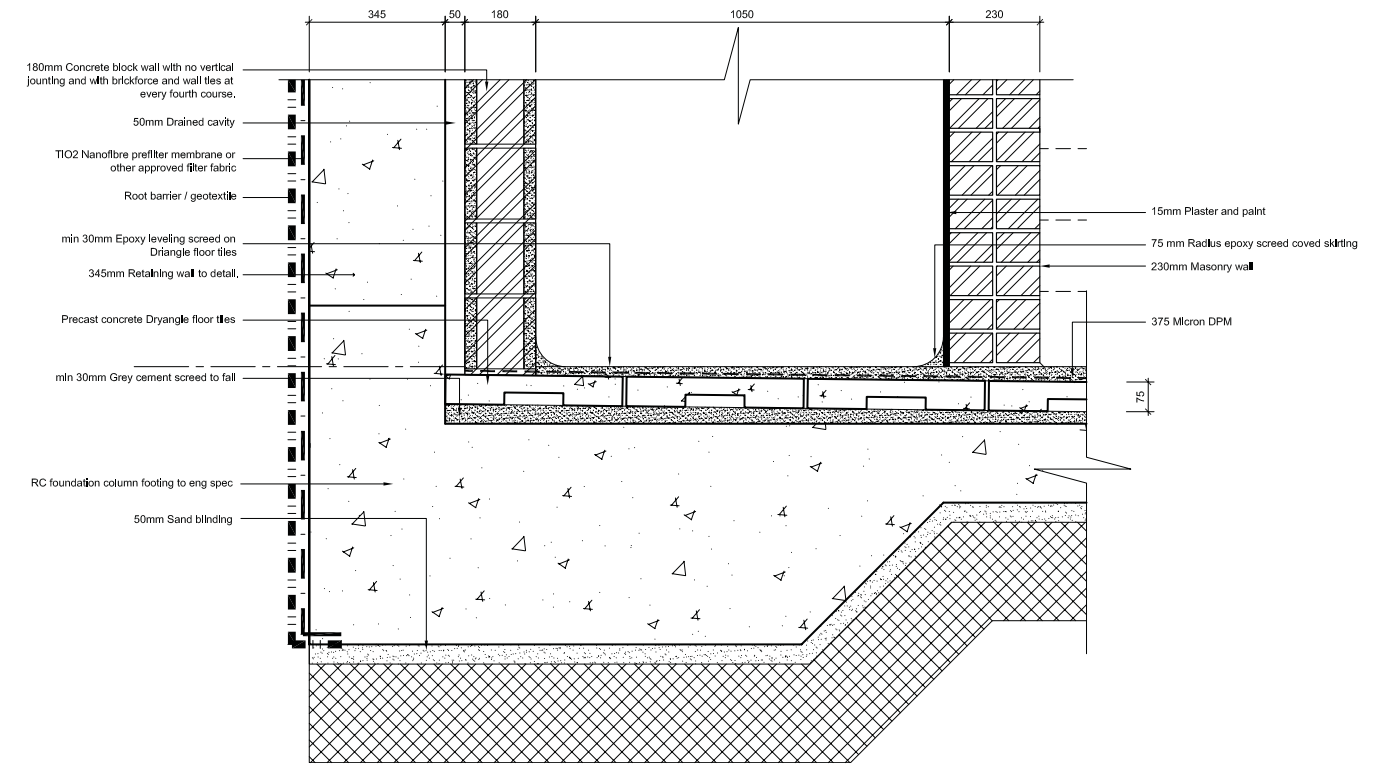
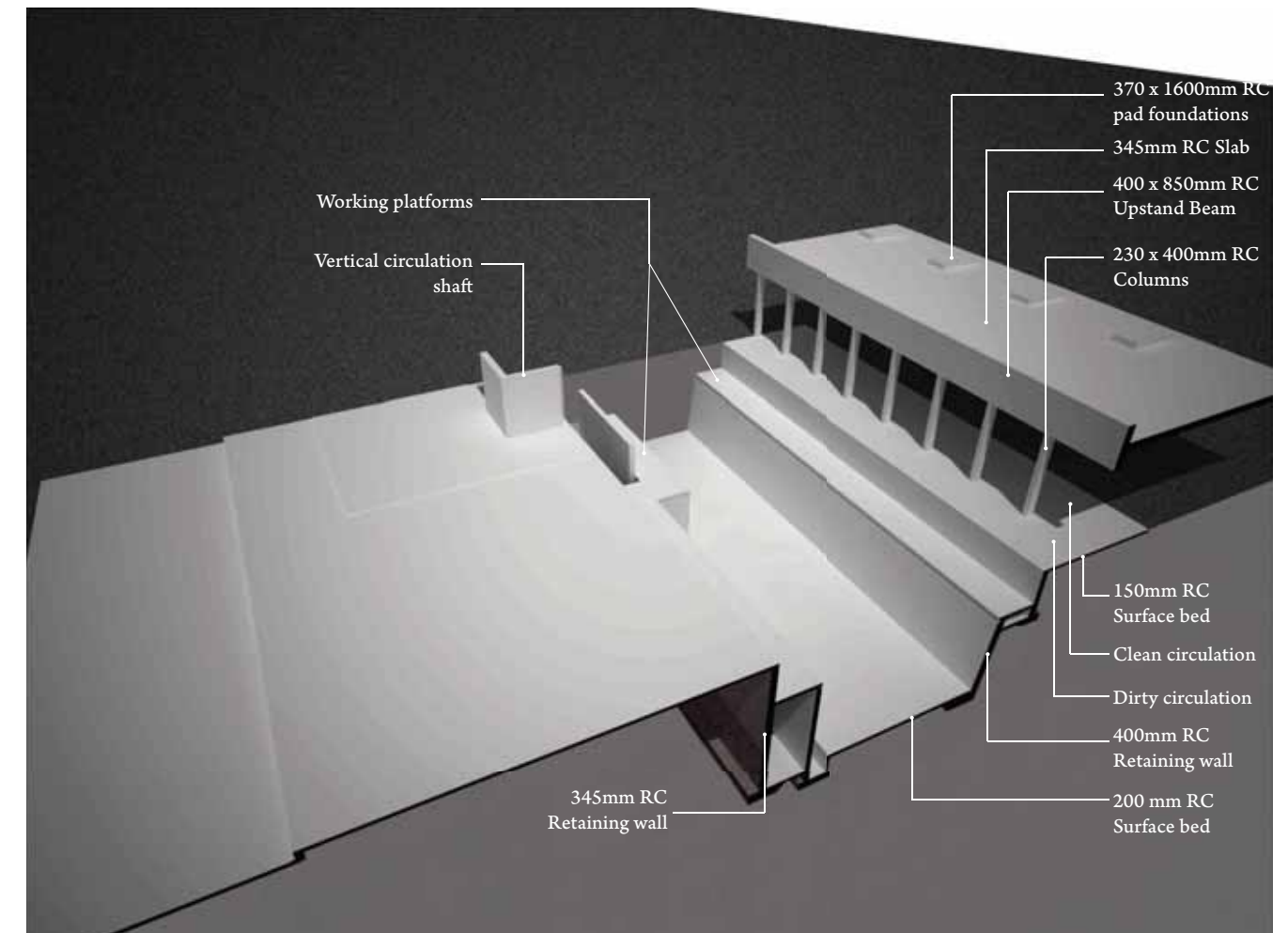

Figure - 9.6 - Above - Detail of the retaining wall on the northern side of the slaughter pit (By Author).

Figure - 9.7 - Below - 3D section render of the slaughter pit and the connection of the processing spaces on top of it (By Author).



Tectonic - The Frame

The roof over the pit was generated from two design informants. Firstly, the concept of the roof as the central nervous systems of the abattoir, as it has to contain most of the services and systems. Secondly, it was designed around environmental considerations, to harness natural light and ventilation.

The resultant is a portal frame steel structure shaped around the environmental elements. The roof slopes from the north down to the south allowing north light to enter the slaughter space.

The roof creates a internal space for the systems and is shaped to create space for service runs and circulation. (Refer to Fig 9.9 - 9.10)

The roof over the pit and the pavilion roof become one, with the processing pavilion roof articulated as a lean to structure onto the portal frame.

The portal frame is broken where it connects to the concrete structure which provides support on the southern side. The portal frame column is fixed to a 800 x 400 mm reinforced concrete upstand and the floor beam is connected to the side thereof.

The frame allows for openings on the northern and southern sides, and is narrow enough to cross ventilate.

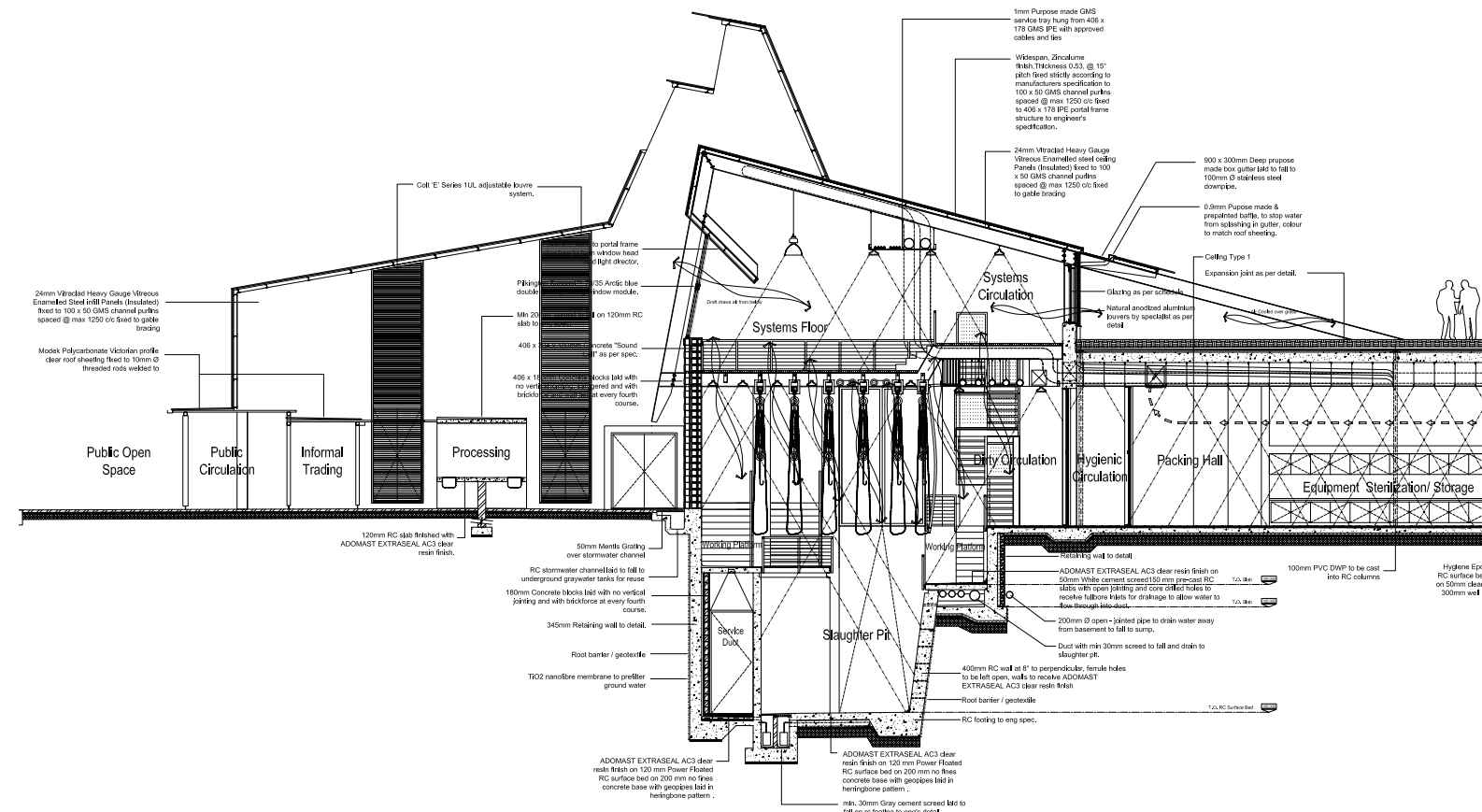

Figure - 9.9 - Above - Technical section through the slaughter pit (By Author).

Figure - 9.10 - Below - 3D section render of the portal frame roof over the slaughter pit.

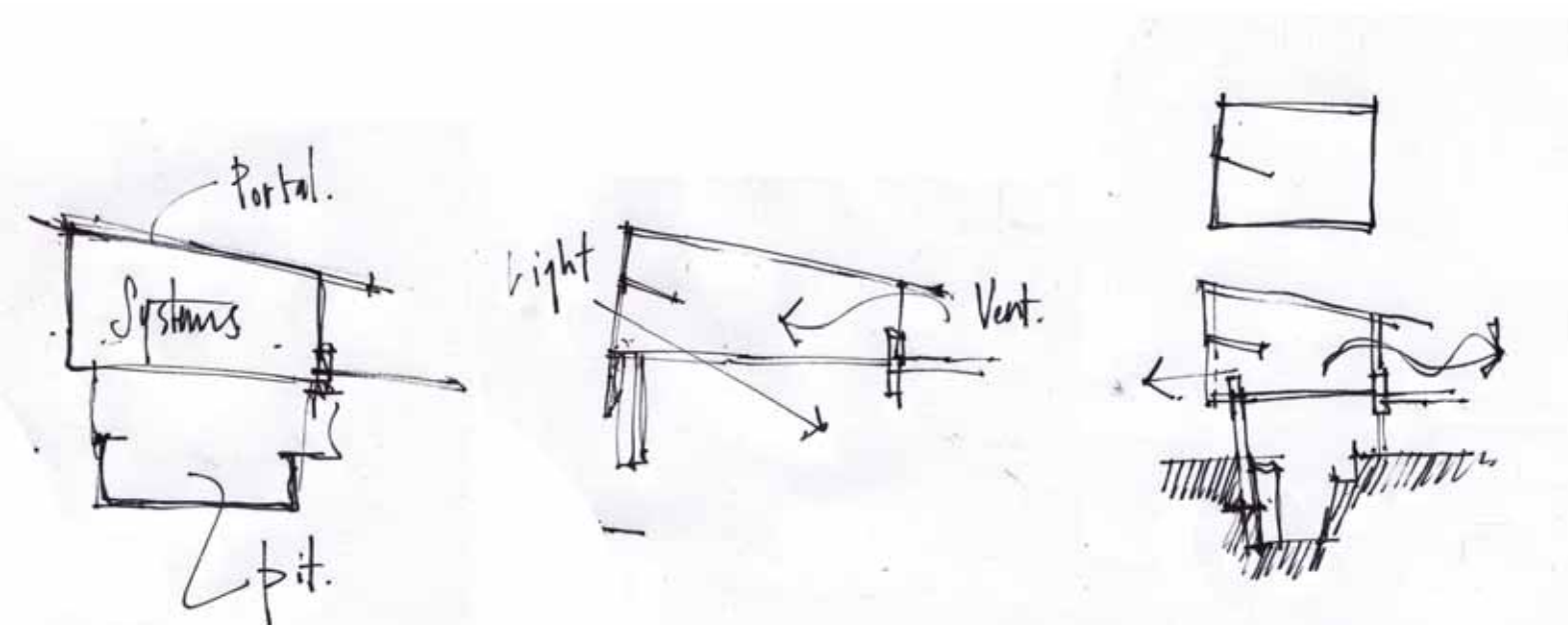

Figure - 9.8 - Early conceptual sketches of the roof (By Author).

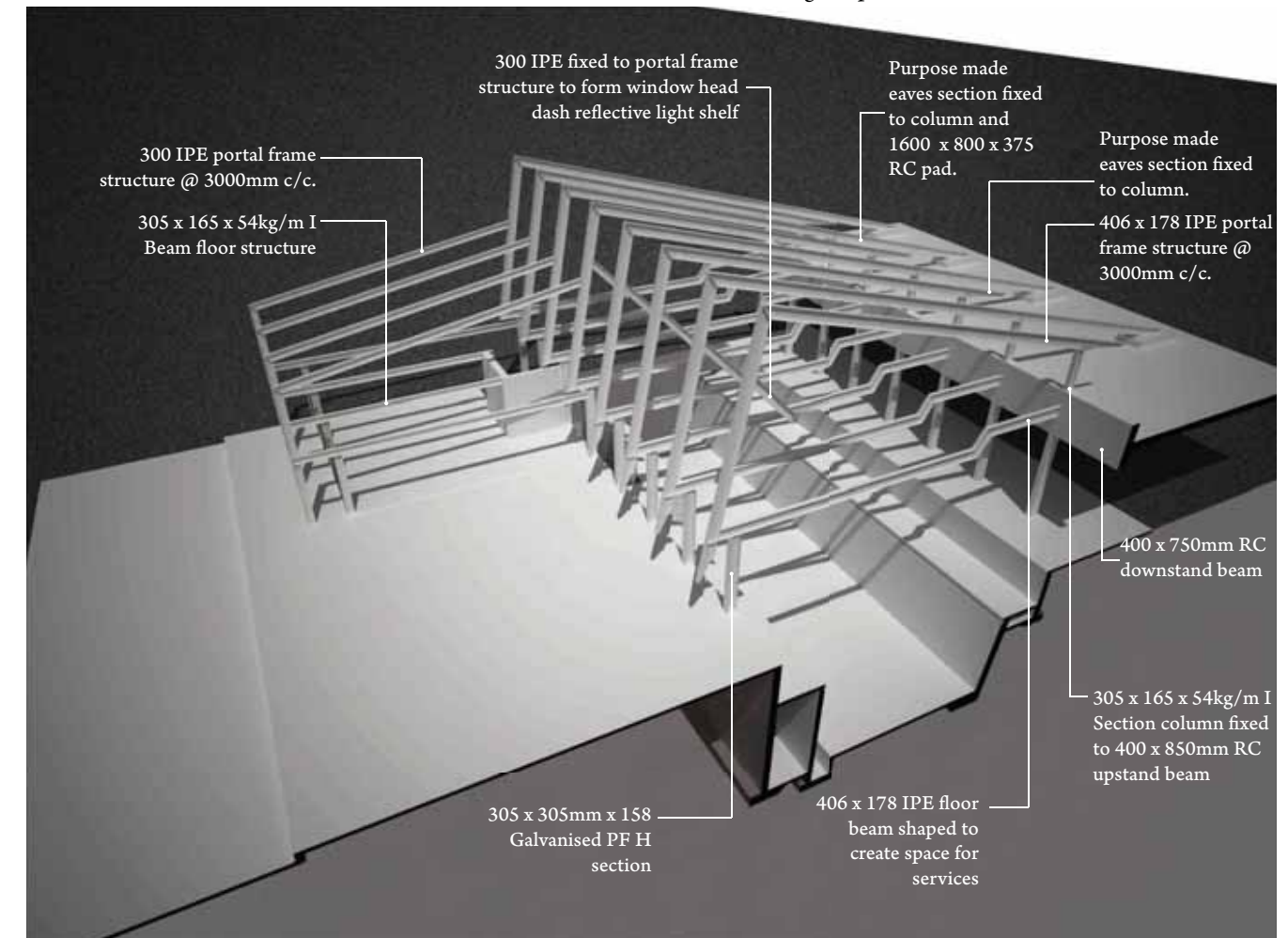

Figure - 9.12 - Opposite - Image of explorative model built of the roof structure (By Author).

Figure - 9.11 - Below - Image of explorative model built of the roof structure (By Author).



Figure - 9.13 - Image of explorative model built of the roof structure (By Author).

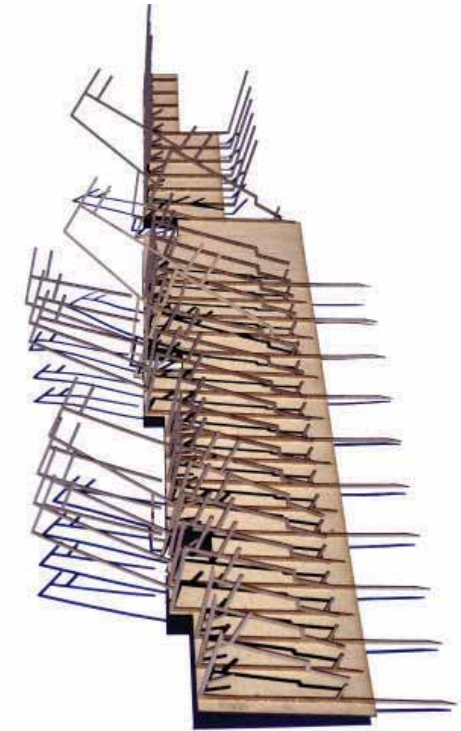
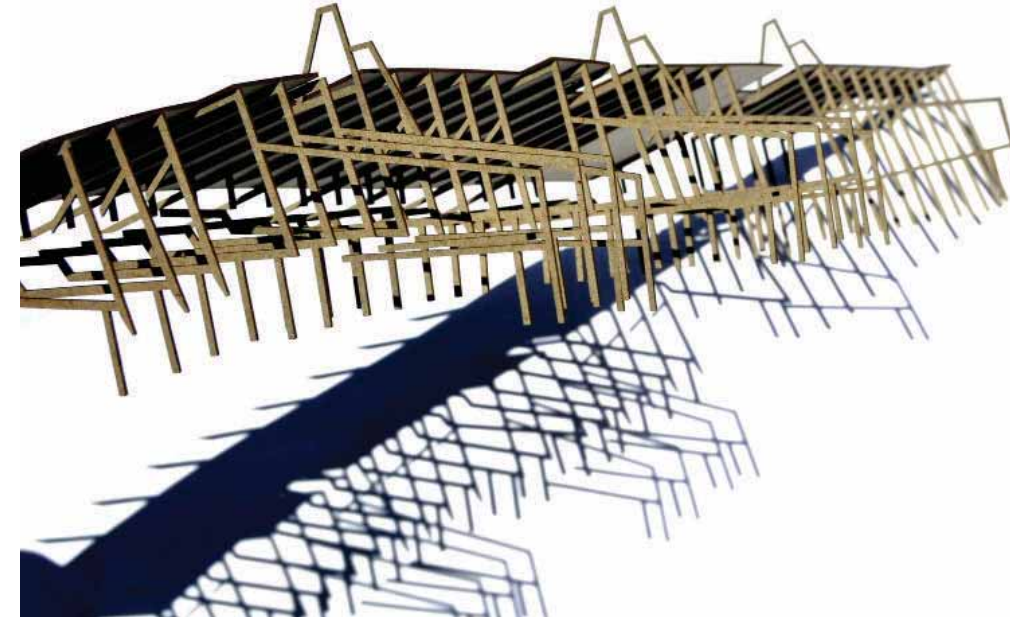
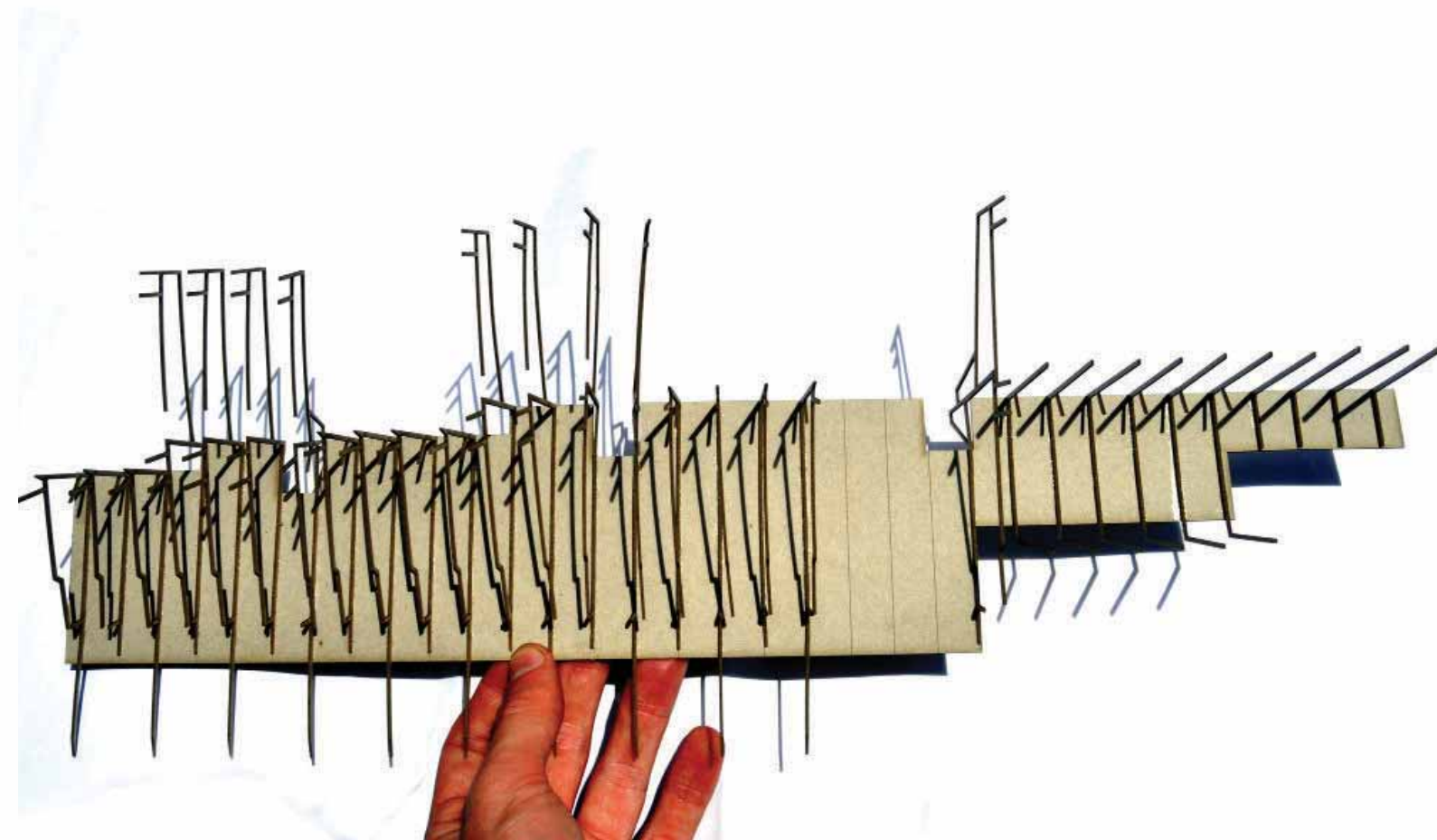

Figure - 9.14 - Below - Image of explorative model built of the roof structure (By Author).



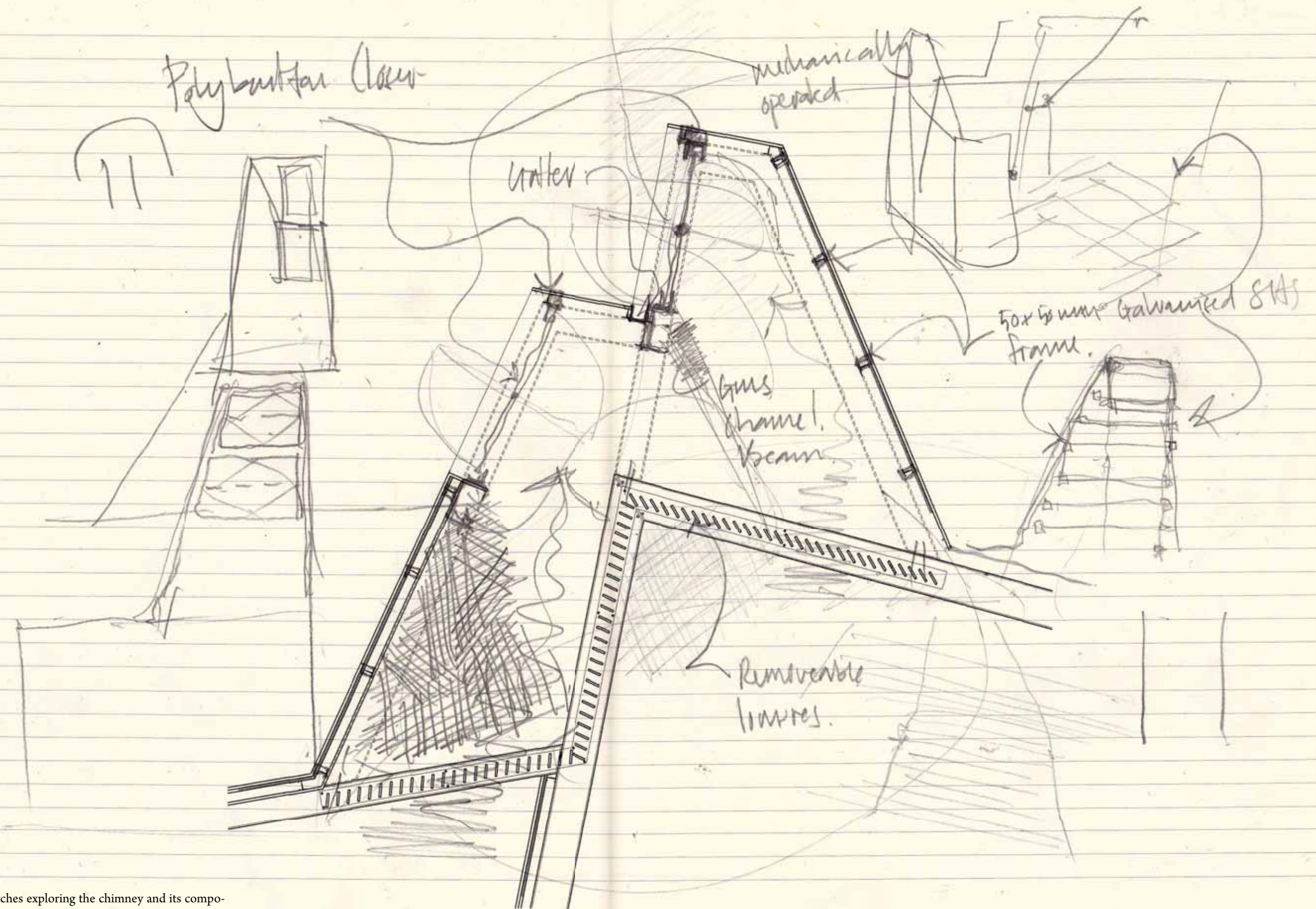

Figure - 9.15 - Sketches exploring the chimney and its components (By Author).

The Chimneys

The chimney is designed around passive principles and active systems. The highest point of the roof flows into the chimney to allow warm, stale air to exit. The chimney promotes constant natural circulation and air changes.

There are systems components located within the chimney such as an air scrubber system, which removes bad smell from the air before allowing them to exit, air conditioning condensers and the extraction system which is also connected to the air scrubbing system.

After a consultation with a mechanical engineer, Mr E. Groenewald, these systems were placed within the chimney. It was advised to place the condensers and the extraction system within close proximity so that the cool air which is extracted can be recycled by the condensers, which relieves the mechanical cooling system from excessive work, saving energy.

The chimney has a automated flap which opens and closes as required, controlling the ventilation or just keeping the rain out. The operation of the flaps will be overseen by the systems manager as he will constantly monitor the building performance.

The chimneys occur at each output pavilion and there are five in total. The first pavilion, housing the administration, does not require the chimney for ventilation and systems, and utilises it as a light well.

The chimneys also serve the processing spaces within the pavilions. The pavilion roofs are shaped into the chimneys of the slaughter pit roofs creating one chimney, serving both.

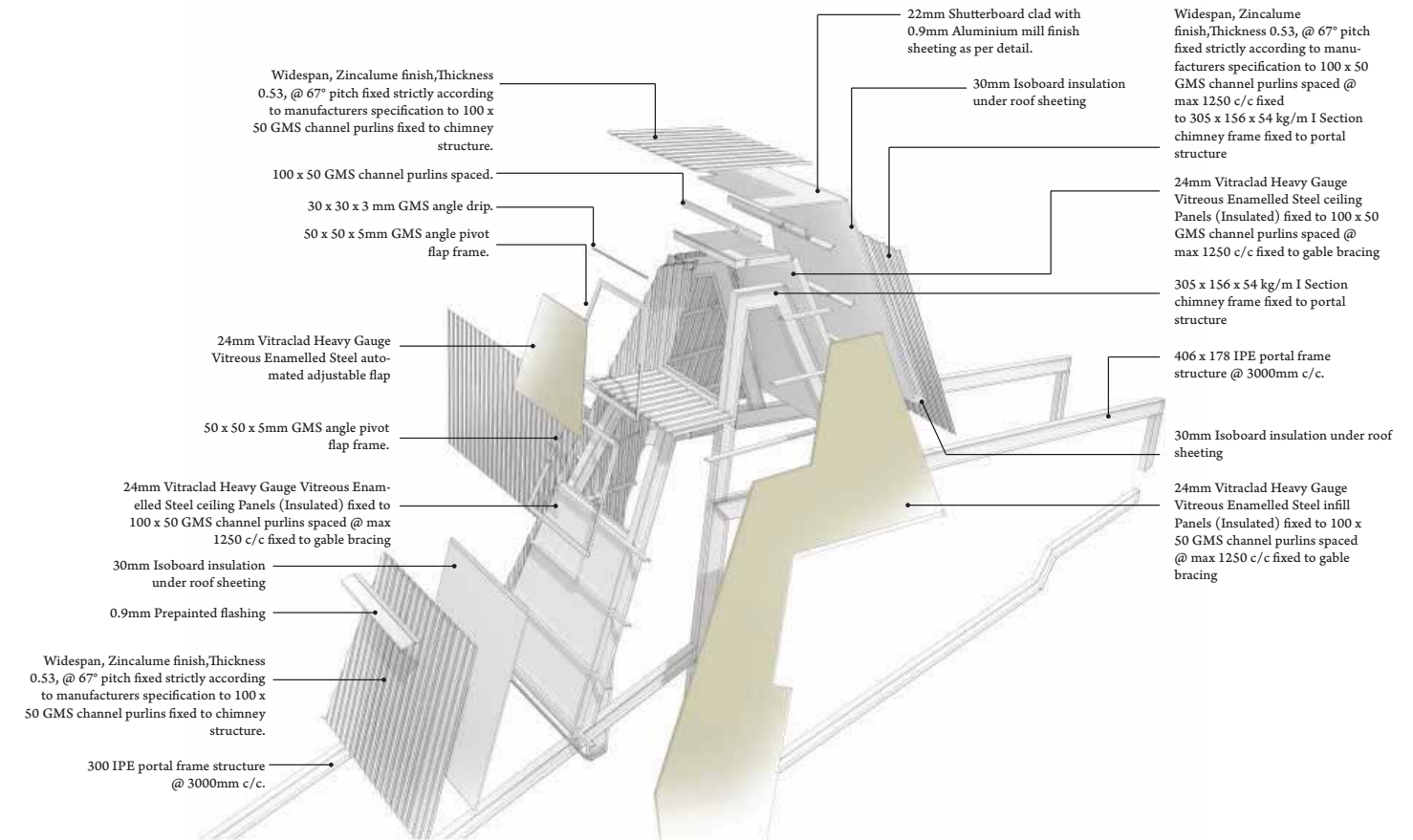

Figure - 9.17 - 3D Exploded detail of the chimney and its components (By Author).

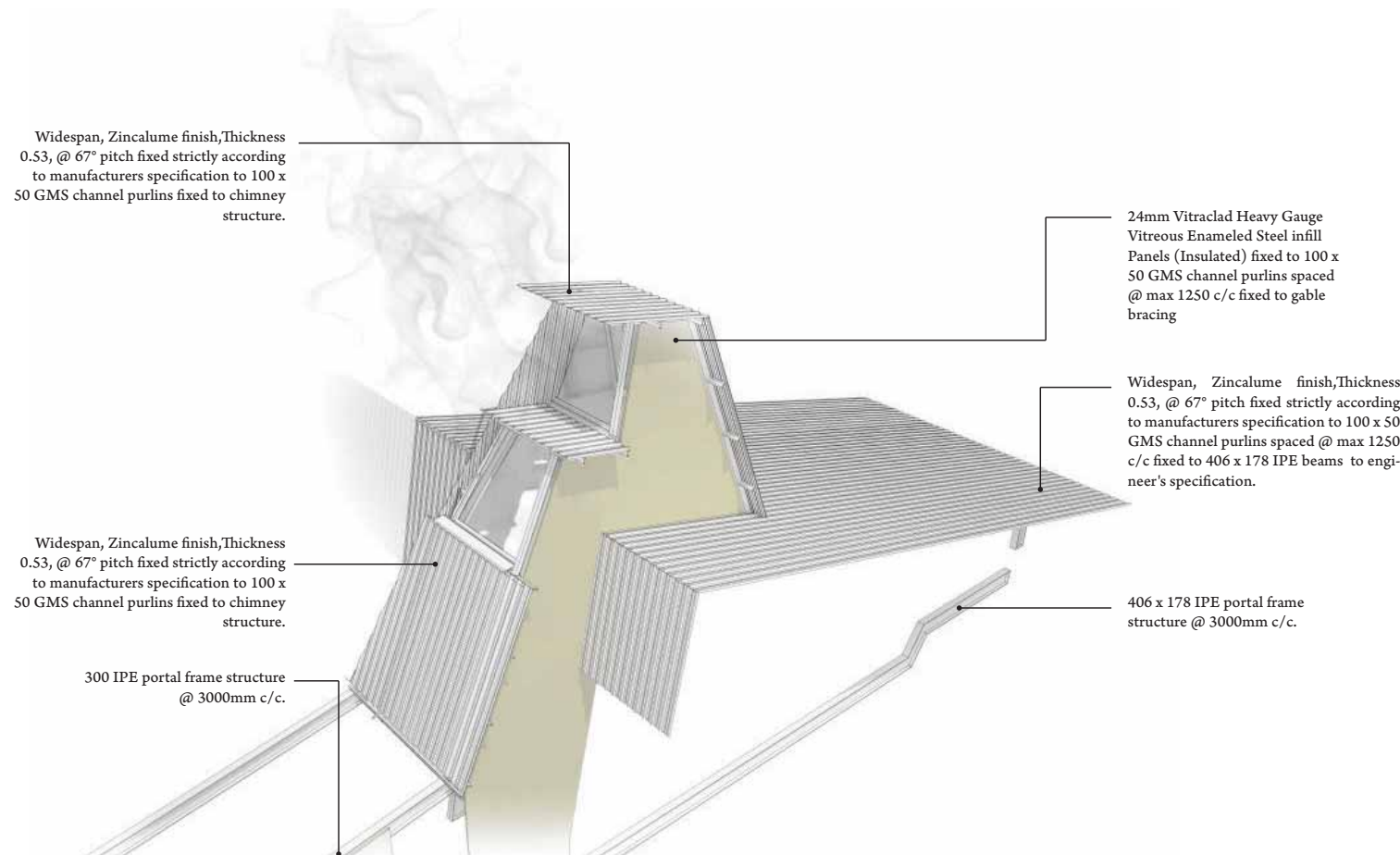

Figure - 9.16 - 3D Detail of final chimney, its components and materials (By Author).

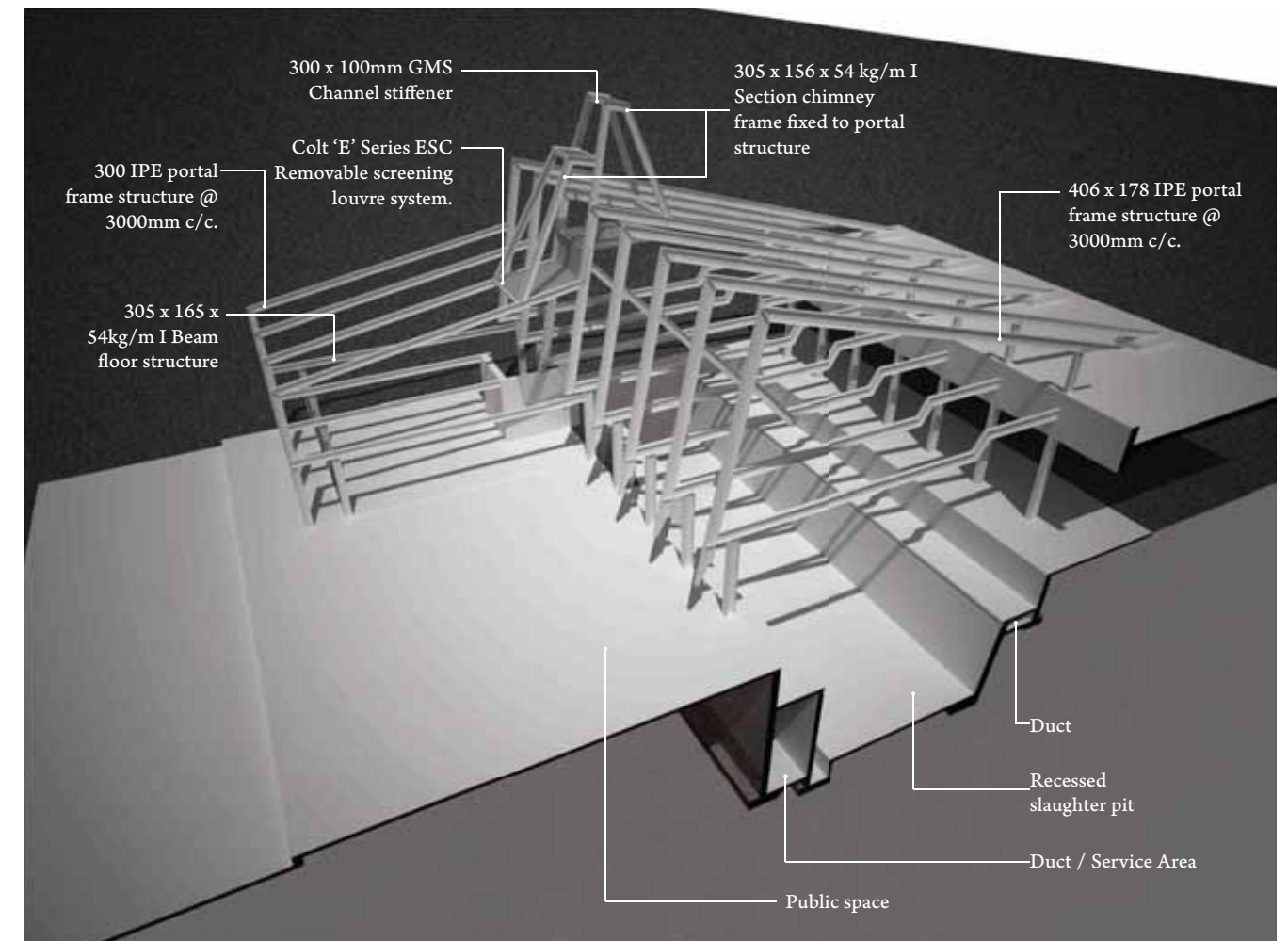

Figure - 9.18 - 3D Section render of the frame with the chimney structure extending from it (By Author).

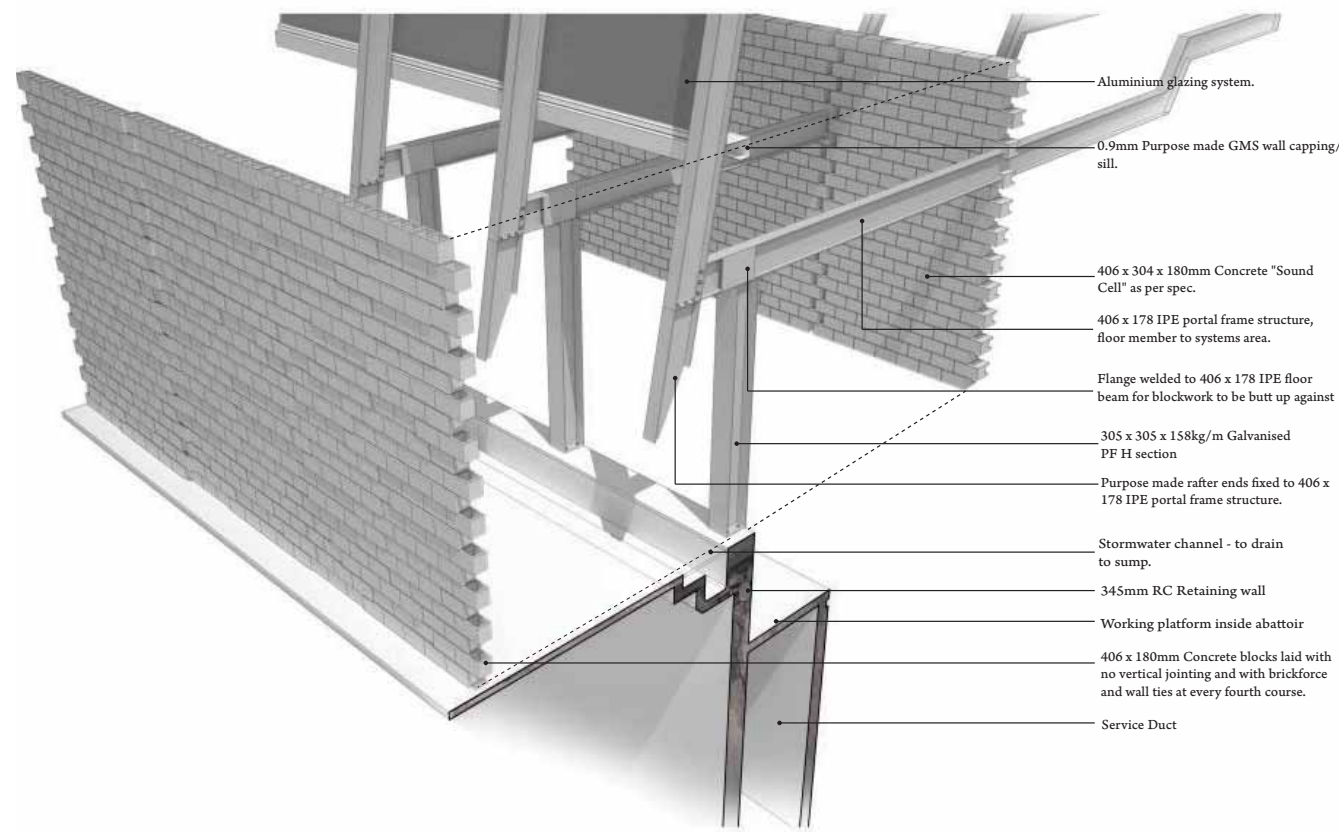

Figure - 9.19 - Above - 3D exploded detail of the wall, the portal frame and its components (By Author).

The Skin

The first part of the building skin discussed is the wall, which separates the slaughter pit from the high street.

The wall has to separate the high street from the slaughter pit, and absorb the extreme noise generated inside the abattoir. Numerous products were researched and the "Sound Cell" acoustical masonry unit by Fendt was finally decided on.

This concrete masonry unit implements a unique sound absorption system within. Two layers of sound insulation apply absorption and diffusion principles, and offers almost 100% sound absorption efficiency. The block, with its unique shape, offers a unique textured appearance when used in large quantities, like in the abattoir.

The inside skin of the abattoir wall is to be constructed of the "Sound Cell", with the external layer constructed of standard concrete blockwork. These two layers sandwich the portal frame columns. The external layer of blockwork will be laid without vertical jointing, and staggered in horizontal groups (refer to Fig 9.19) to give the appearance of long linear blocks stacked

on top of each other. This is done to emphasise the linearity of the building and the process inside.

The wall is designed in panels of three meters, which relates to the building grid. Therefore the panels and the portal frames coincide, with expansion joints at the wall's intersection with the columns.

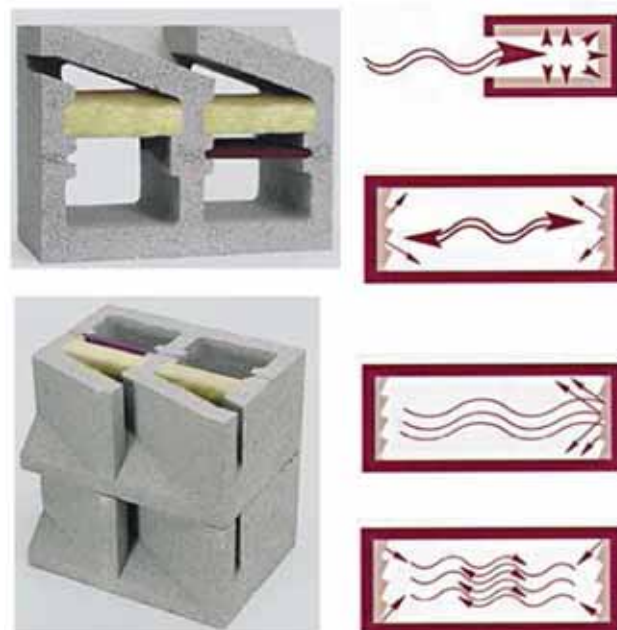

Figure - 9.20 - "Sound Cell", Diagrams of the acoustic principles the block uses to absorb sound.

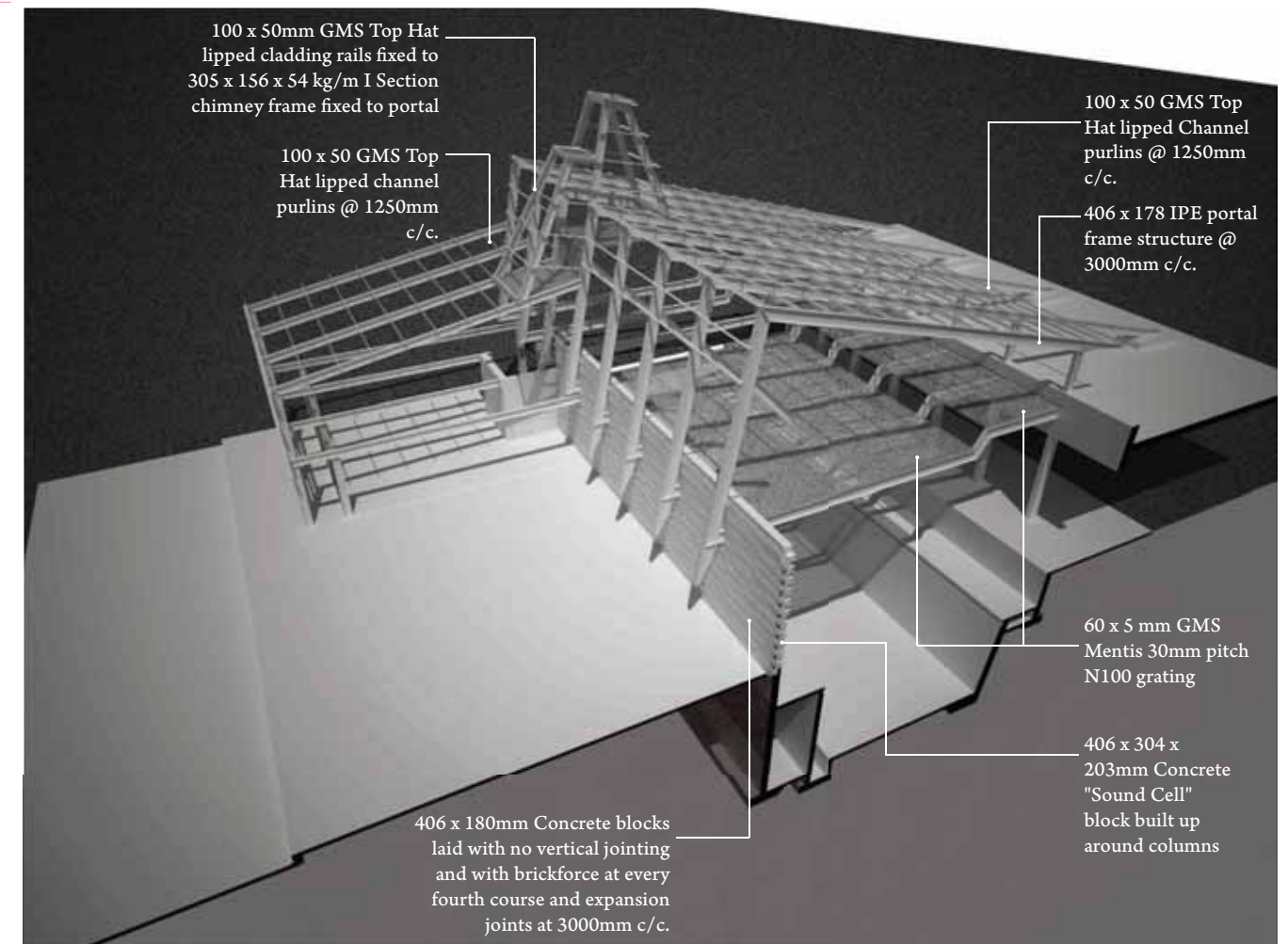
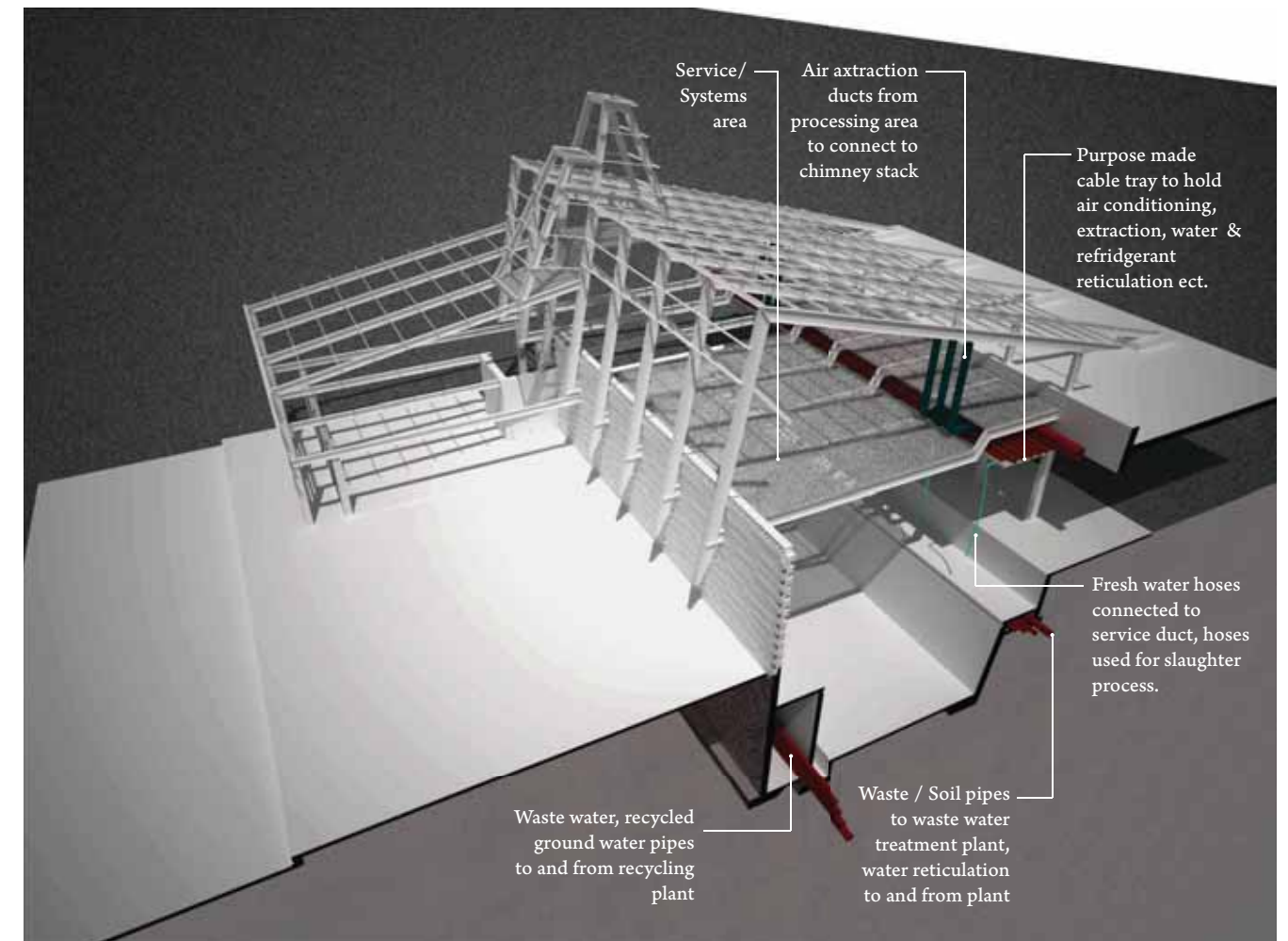

Figure - 9.21 - Above - 3D Section render of the frame, system floors and the wall opposing the high street (By Author).

Figure - 9.22 - Below - 3D Section render of the systems added (By Author).



The Roof and its Connections

The roof is designed to appear as if it is floating above the building, which grows from the ground. This creates openings beneath the roof, which create areas where ventilation and light gain can be controlled.

The roofing material chosen is Widespan profile with a Zincolume finish. Zincolume has a very long life-span and requires less maintenance. The widespan profile is a IBR profile with intermediate ribs to strengthen the sheet.

The northern edge of the roof connects to the wall, discussed on page 192, with glazing. The glazing also requires sound insulating properties, and therefore a decision was made to use a double glazing. The interior of the abattoir requires natural light to create better working conditions, without unnecessary heat

Figure - 9.23 - Below - 3D Deetail of the roof connection on the southern side to the concrete upstand (By Author).

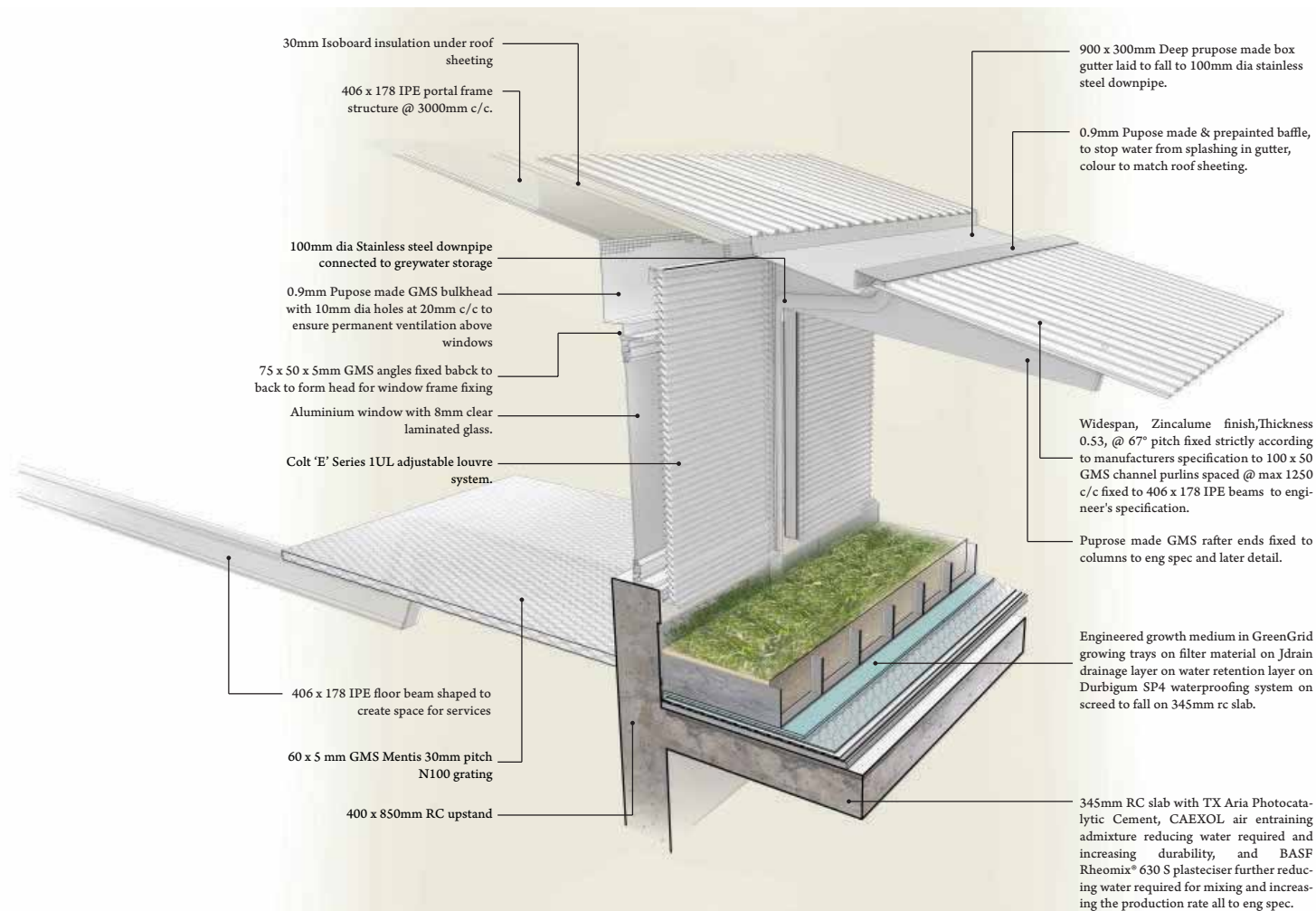

gain. Pilkington Suncool Artic blue glazing has been specified, due to its thermal insulating properties. The tinted glass allows for ample light to enter the building without overheating and glare.

On the southern edge, the building connects to the concrete upstand with glazing panels and a louvre system. Double glazing is not required on the southern edge, as it does not receive direct sunlight, and it is orientated away from the high street and the noise have little to no effect.

The floor inside the roof space is constructed of a structural mesh flooring system allowing the light that enters into the roof space to penetrate the slaughter space.

A adjustable louvre system allows the ventilation, south light gain and views into the building to be controlled. Refer to Fig 9.26 for construction details.

Figure - 9.24 - Opposite - Technical Section A-A, a cross section through the slaughter pit and the roof at the chimney (By Author).

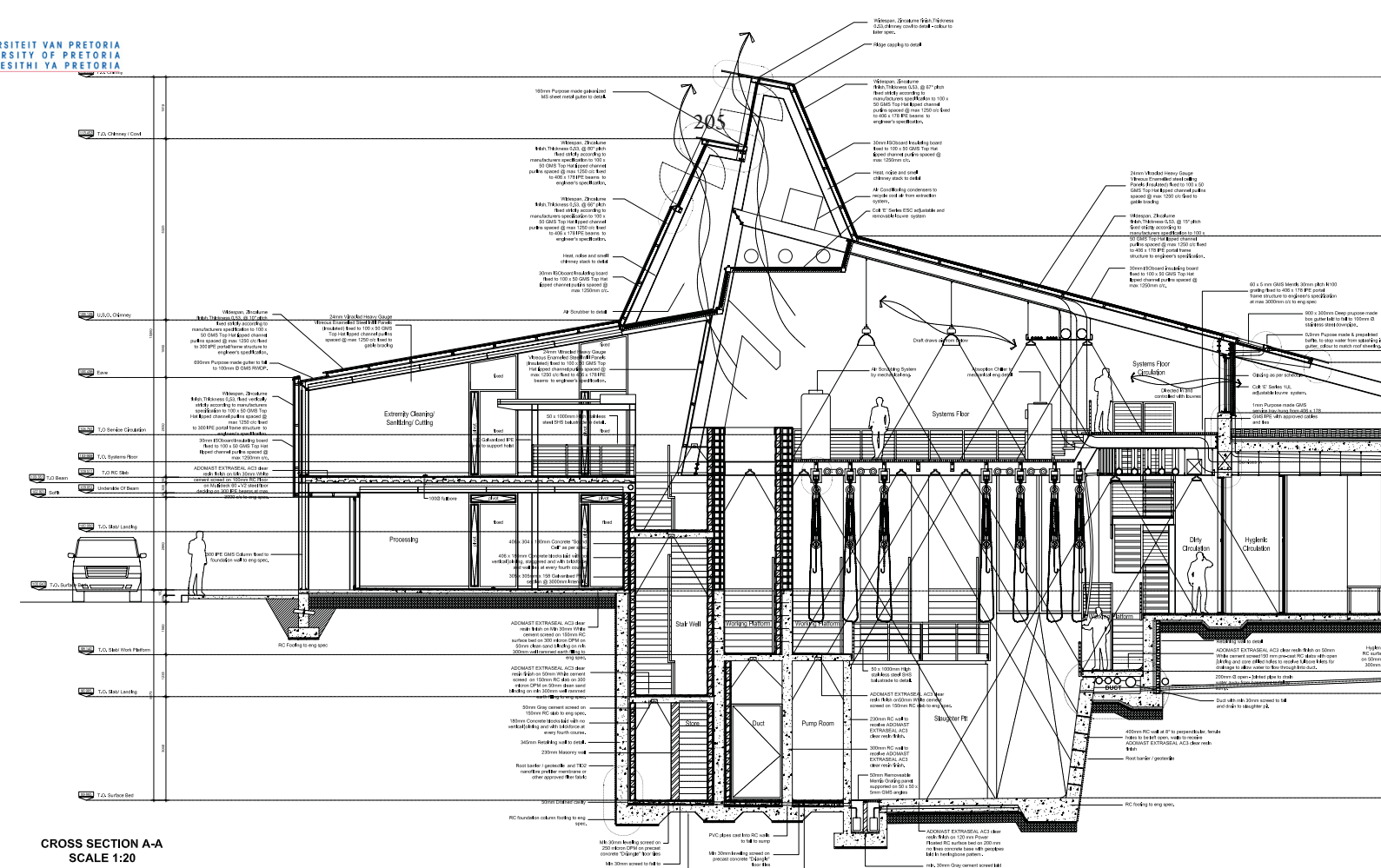

CROSS SECTION A-A
SCALE 1:20

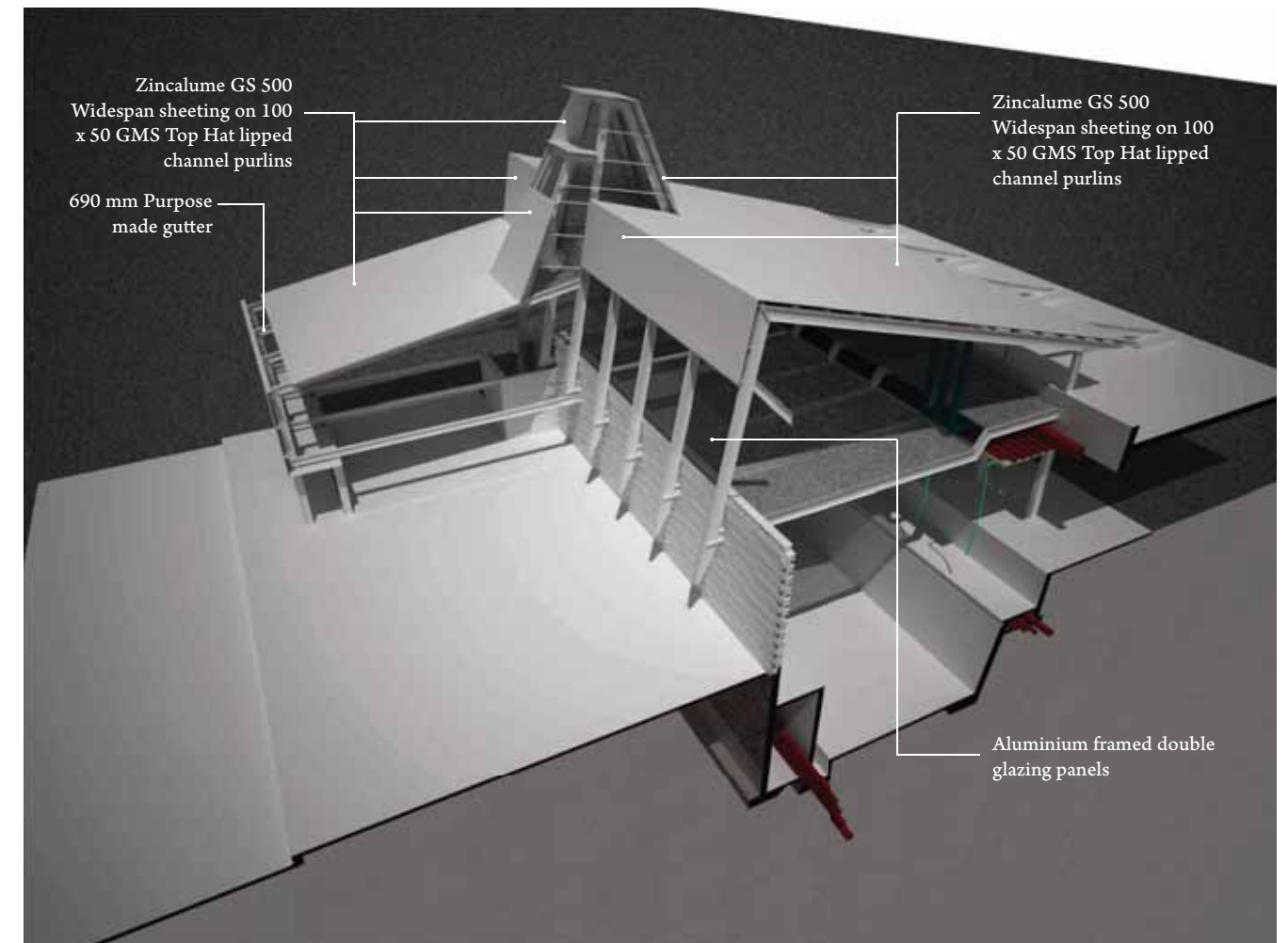

Figure - 9.25 - 3D section render of the module with the Widespan sheeting added (By Author).

The Layers - Public Interface

Fig 9.29 depicts the final module which is to be repeated along the high street. The only difference is that each module will step back further than the previous as the slaughter pit becomes narrower concentrating the process. This allows the pavement to grow in front of these pavilions, encouraging more activity toward the end of the process which terminates in the meat market.

The public element of the processing pavilion is a very basic structure, which is based on what you might find in a harbour where fresh fish are processed. Closest to the abattoir there is a solid structure which contains basins and counters for working where people, small business owners and local vendors can process products made available directly from the abattoir.

The second layer is a space made available for vendors to set up stalls to sell products made from the abattoir waste directly to the public. This structure consists of a simple lightweight steel SHS (Square Hollow Section) post and lintel system with a polycarbonate sheeting covering it. This space is to be freely appropriated by the public and vendors, completely filling this space.

The final layer is an undercover walkway for the public, leading them parallel to the vendor space, all along the abattoir. This walkway starts at the bus stop on the western edge of the site and terminates in the meat market on the eastern edge of the site.

As seen in Fig 9.29, the pavement becomes wider as the building steps back, the building steps back as the process becomes narrower, allowing more public activity around these areas. This concentrates people at the more public end of the process in larger numbers where at the beginning of the process less people can circulate around these spaces. The tighter spaces are located at the killing end of the abattoir, and the more abundant public spaces around the processing side. Therefore, the abattoir process imposes itself on the flow of people in the high street.

When processing is done for the week the building can act as a market for informal trading along the entire high street including the meat market. This allows the building to be functional seven days a week increasing the sustainability of the project and breaking away from the mono functional nature of industrial buildings

Figure - 9.29 - Right - Plan of the high street edge of the abattoir with the pavilions and its activities in between (By Author).

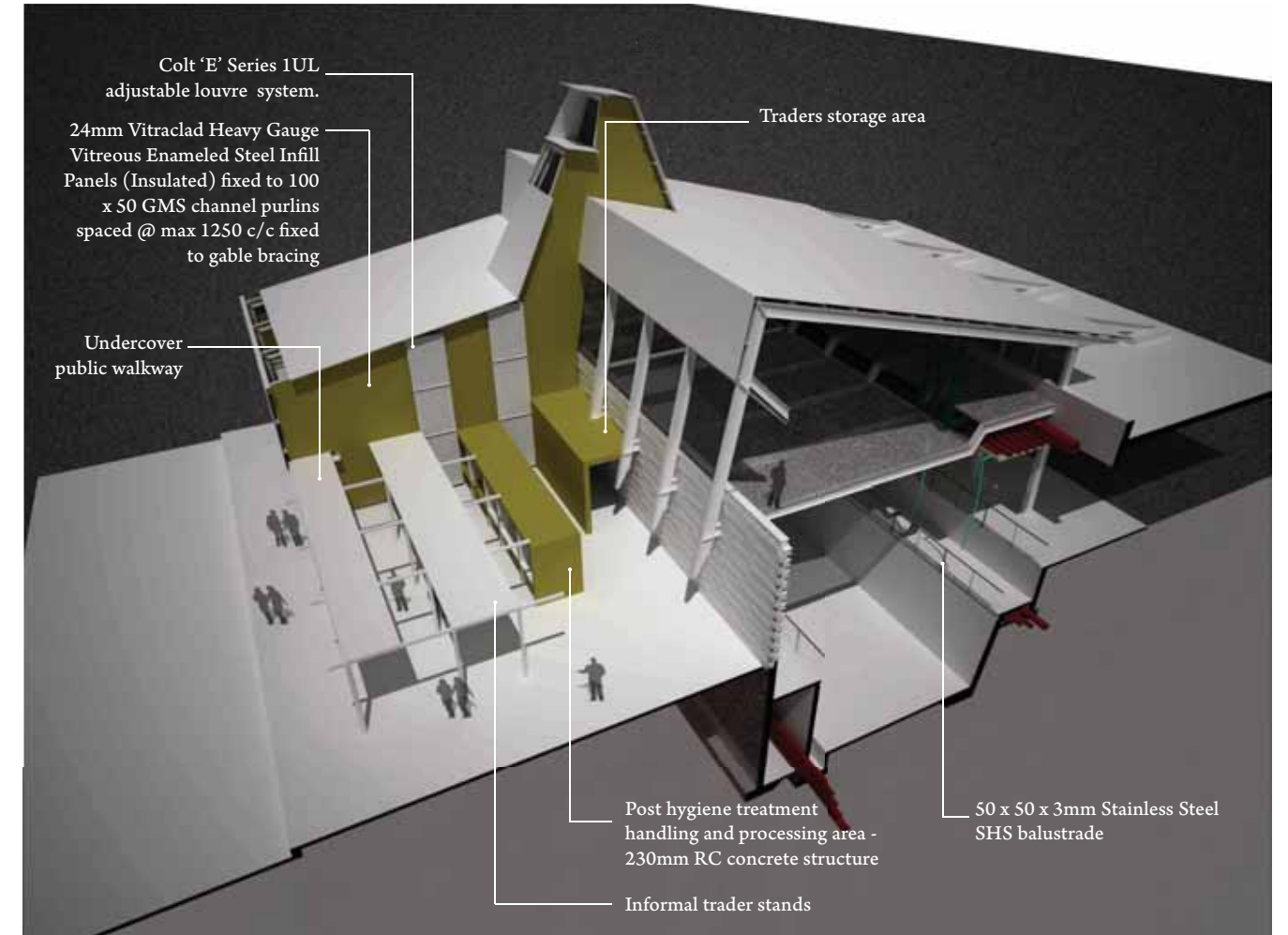
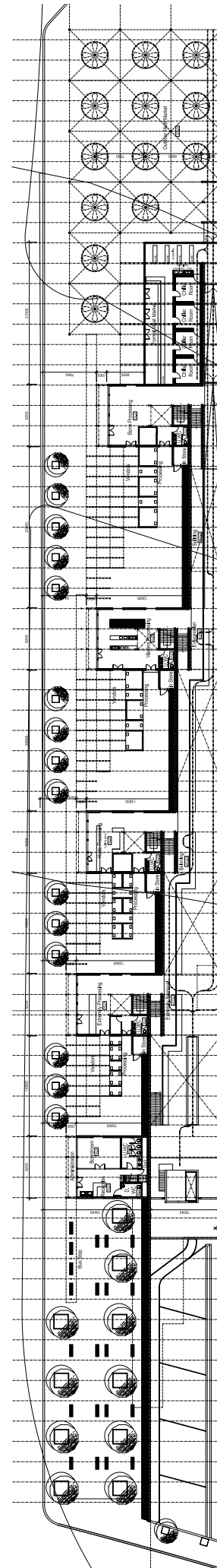
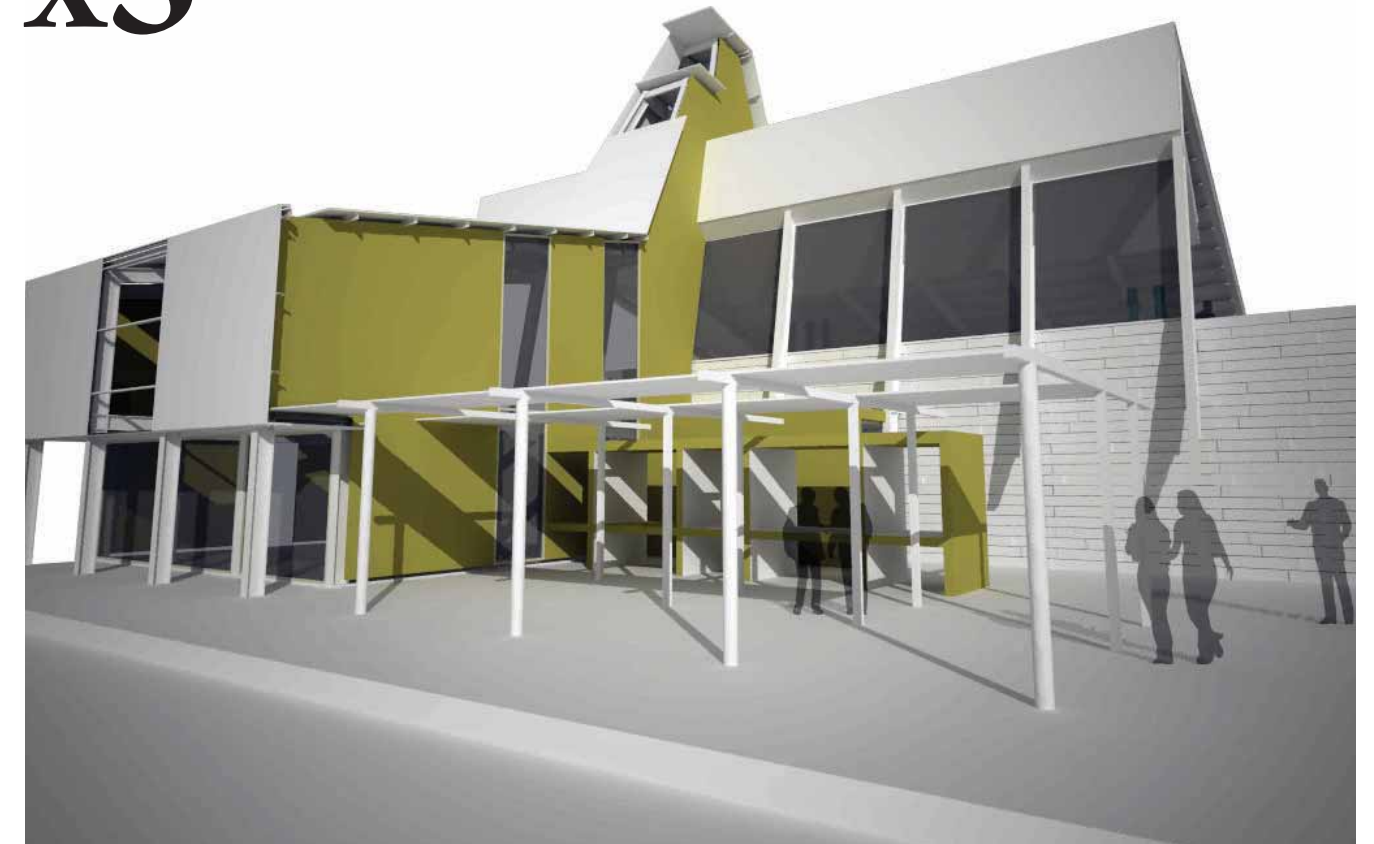

Figure - 9.30 - Above - The final module with the layered public interface. The space is to be freely appropriated by the public (By Author).

Figure - 9.31 - Below - View from eye level of the final pavilion module (By Author).

x5



SOLAR STUDY

Figure - 9.32 - Spring Equinox (By Author).

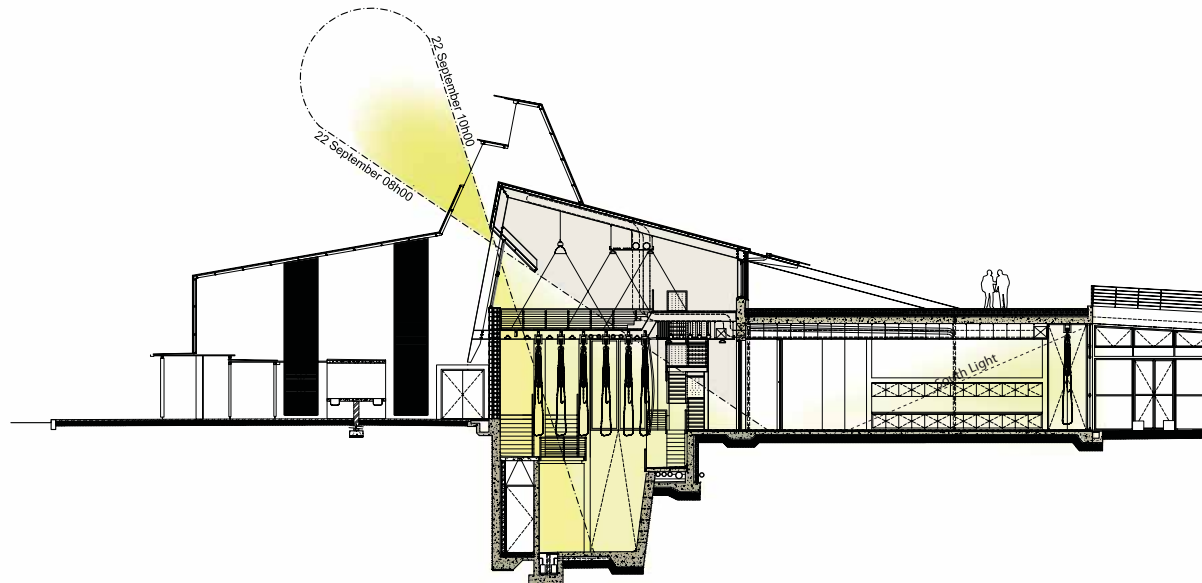

Spring Equinox
Natural light enters deep into the building, making the need for artificial lighting much less during the morning hours. Heat gain from direct sunlight is minimal due to the tinted glazing system. From 10h00 the direct sunlight is restricted

to the pit floor and the processing floors on the northern edge. This light allows backlighting and will not hinder the workers. Constant south light enters the processing spaces. These spaces must avoid any direct sunlight, because these spaces are mechanically cooled to be a constant 7°C.

Figure - 9.33 - Summer Solstice (By Author).

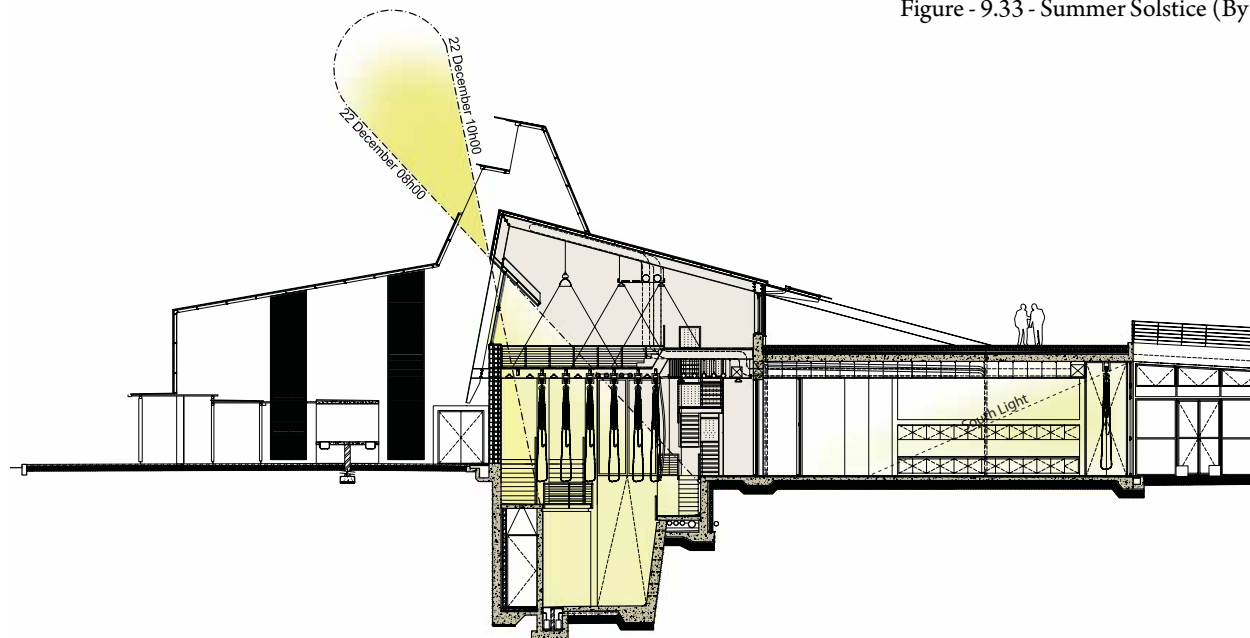

Summer Solstice
The harsh summer sun enters the slaughter pit from 6 am to 11 am. During the early hours of the morning the sun illuminates both working platforms, where after it just il-

luminates the pit and the northern platform. Heat gain is as previously stated avoided by the Pilkington Suncool double glazing module on the northern edge. The glazing system allows maximum illumination with minimum heat gain.

Figure - 9.34 - Autumnal Equinox (By Author).

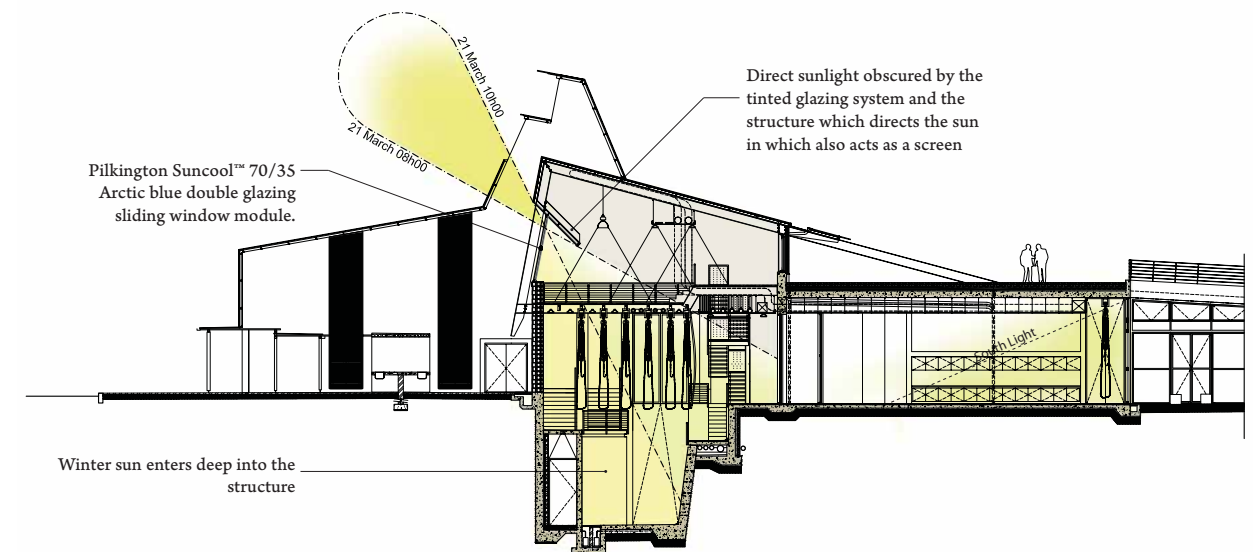

Autumnal Equinox
The sun starts to penetrate deeper into the structure, providing ample light to the slaughter pit interior. Light is mostly kept out of the systems space in the roof by the roof

structure creating a shelf which directs the light into the lower part of the building. The slaughter pit is illuminated well enough to require minimum artificial lighting during the morning hours.

Figure - 9.35 - Winter Solstice (By Author).

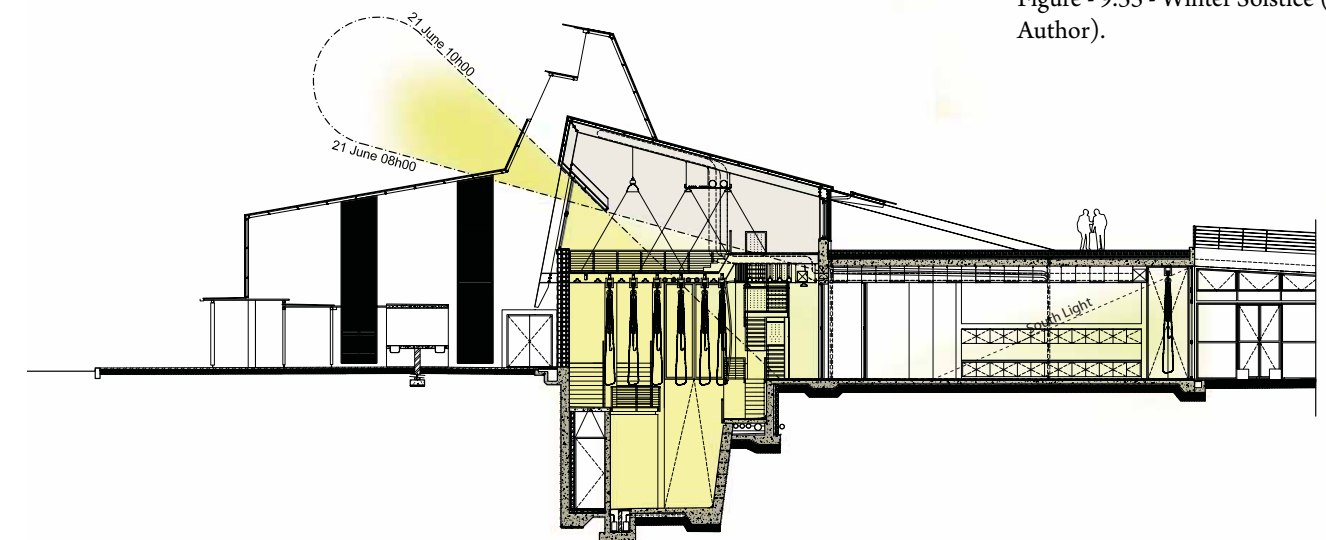

Winter Solstice
Early morning sun enters very deep into the building, illuminating the entire slaughter area. Very little to no artificial lighting is required during the morning hours (8 am - 12am), saving energy. The slaughtering starts at 6 am, therefore artificial lighting will be required between 6 am

and 8 am. The tinted glazing system will protect the workers from direct sunlight and the mechanical cooling system from unnecessary heat gain. The double glazing system with the tinted glass acts as a good insulation, maintaining the ambient temperature within the slaughter area.

SYSTEMS SUMMARY

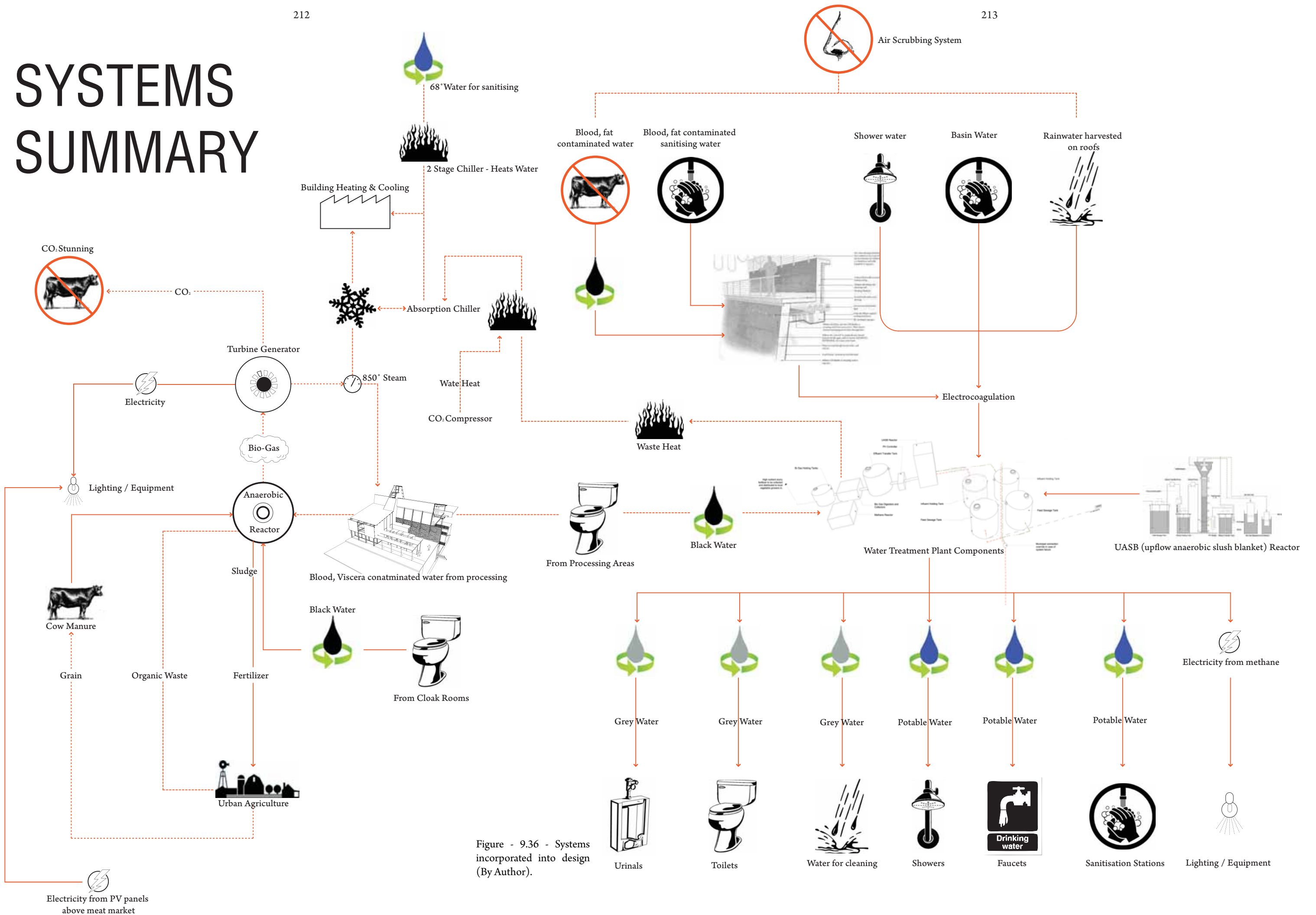

Figure - 9.36 - Systems incorporated into design (By Author).

CONCLUSION

The dissertation investigation showed that industry can be placed within densely populated urban or peri-urban areas by connecting the inherent mechanised processes to the productive urban network and the surrounding community.

The abattoir at the Eerste Fabriek precinct acts as a nodal intervention, connecting two previously separated communities. It also acts as a generator, by understanding the industrial process, the inputs, outputs and waste thereof, these could be directly connected to the public, and aid the creation of a productive interface for industrial architecture.

The intervention responds to the historical context and revives the fallen industrial site into a new productive centre. The entire productive centre is built on the waste of the abattoir around which economic opportunities are exploited in the form of small business incubation centres promoting small businesses in the area to grow, and informal trading around the waste products.

To integrate industry into the public realm, the building had to act as a positive power plant, which harnesses the environment to optimise production and generates energy from its processes. By adhering to the Hannover principles for regenerative design the process of positively integrating the abattoir into the public realm was simplified. These principles also guided the project into making relevant and productive connections to all spheres of the abattoirs context.

Passive, active and sustainable principles were incorporated into the design, not only for the benefit of the public outside, but also for the worker inside. The building places emphasis on humanising the internal work environment. This is achieved by designing for ample natural light, ventilation and views from the

building. Three courtyards are introduced into the building, allowing workers to escape the monotony of the repetitive industrialised process.

Mechanical systems are employed to aid these conditions where the passive systems inadequate. The mechanical system is designed as a closed loop system which feeds of itself for energy generation.

The dissertation illustrates the immense potential inherent to industrial processes, how these processes can gain economic viability beyond their output and how once monofunctional architectural edifices can create multifunctional productive networks.

DRAWINGS

SITE PLAN



Figure - 11.1 - Site Plan (By Author).

DRAWINGS

218

219

BASEMENT PLAN - SLAUGHTER PIT

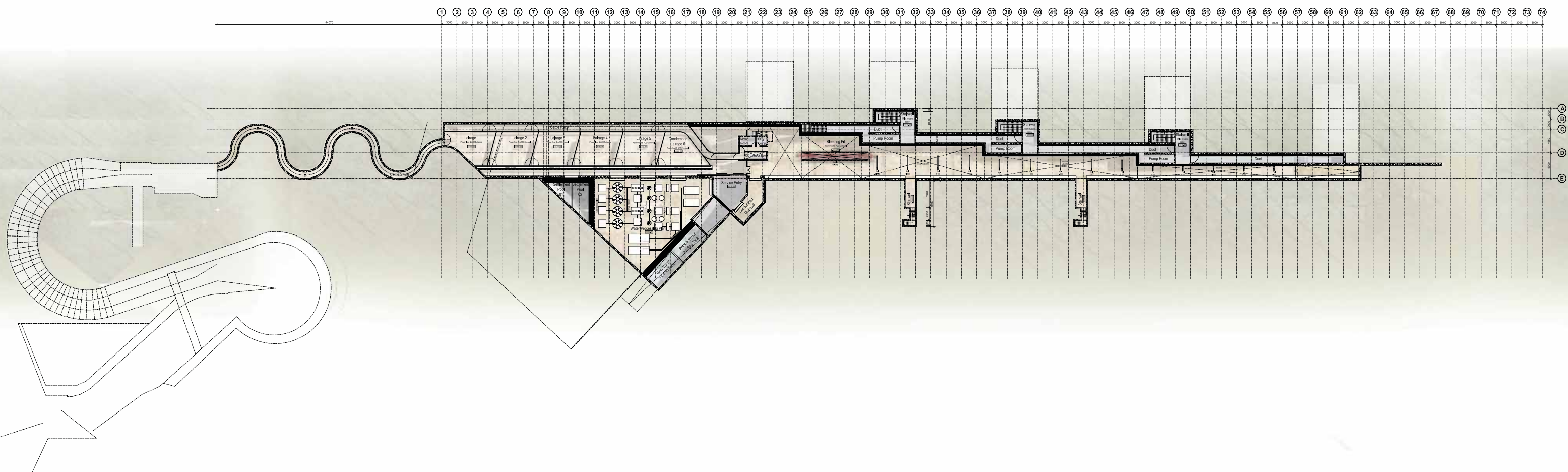

Figure - 11.2 - Basement / Slaughter Pit Plan (By Author).

DRAWINGS

GROUND FLOOR PLAN

220

221

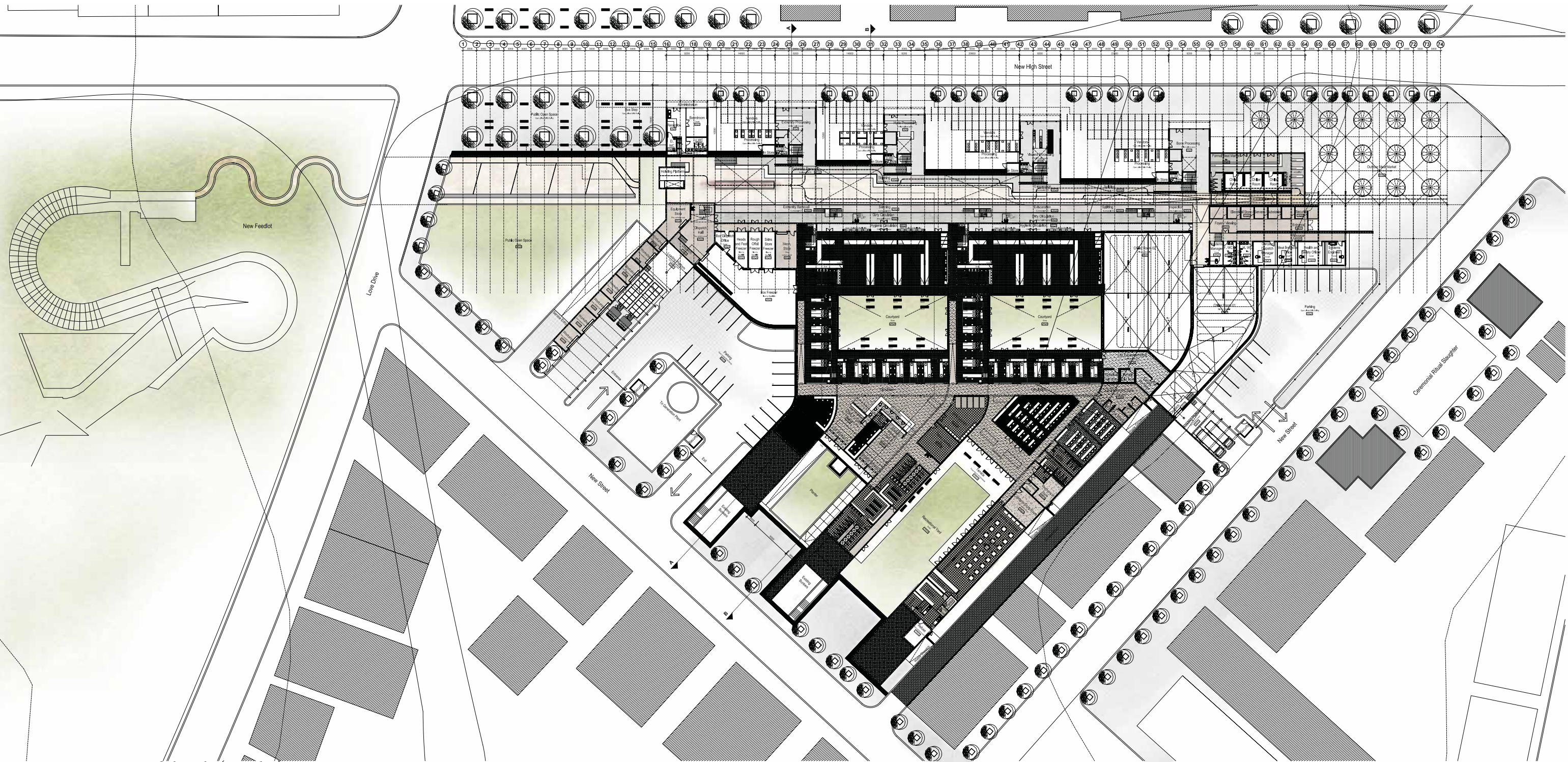

Figure - 11.3 - Ground Floor Plan (By Author).

DRAWINGS

SYSTEMS FLOOR PLAN

222

223

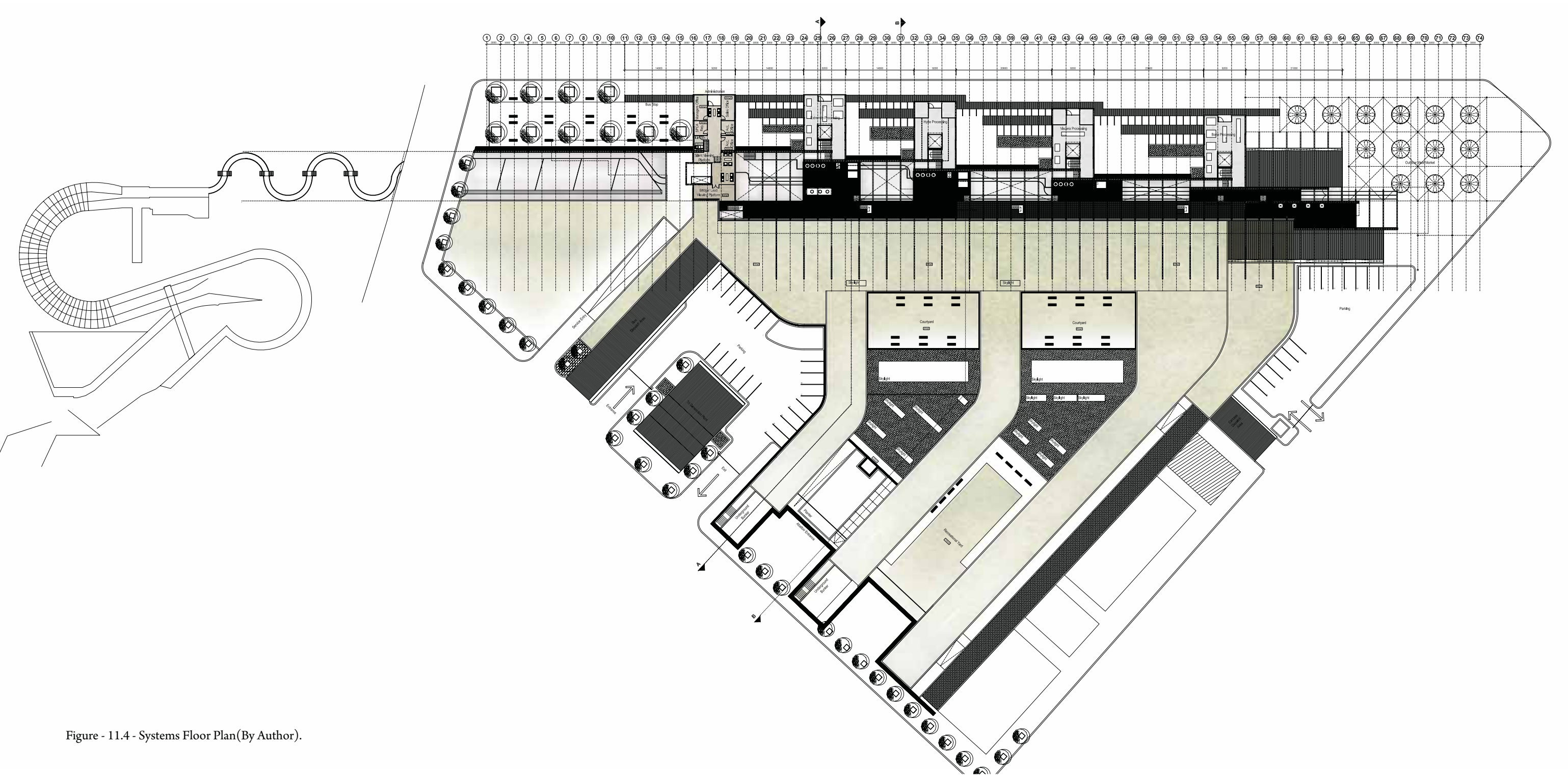

Figure - 11.4 - Systems Floor Plan (By Author).

DRAWINGS

SECTION A-A

224

225

Figure - 11.5 - Section A-A (By Author).

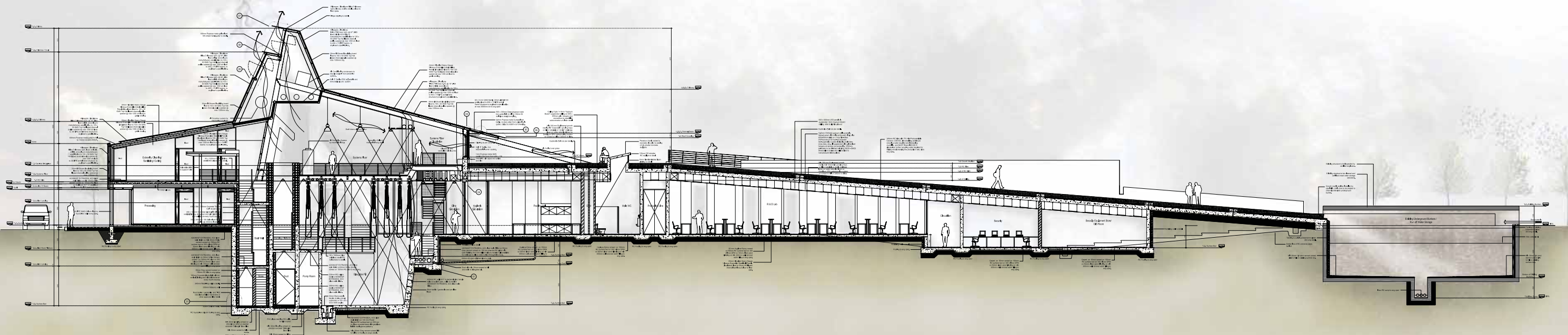

DRAWINGS

SECTION B-B

226

227

Figure - 11.6 - Section B-B(By Author).

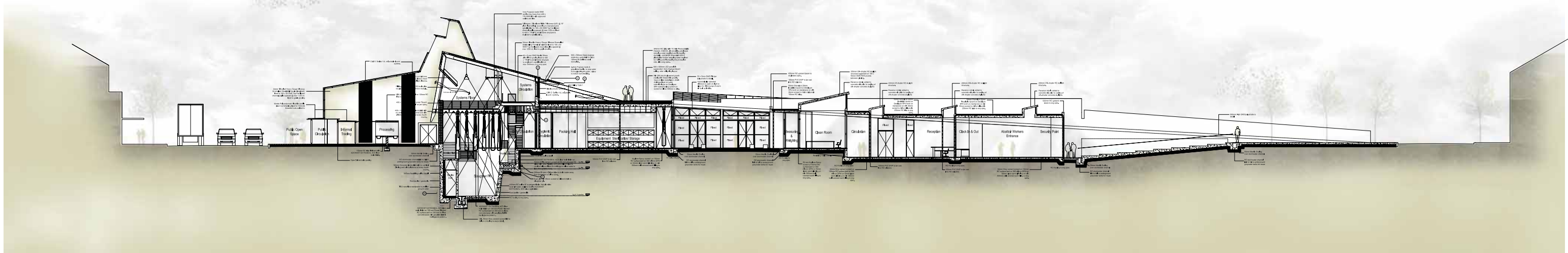

DRAWINGS

HIGH STREET ELEVATION

228

229

Figure - 11.7 - High Street Elevation (By Author).

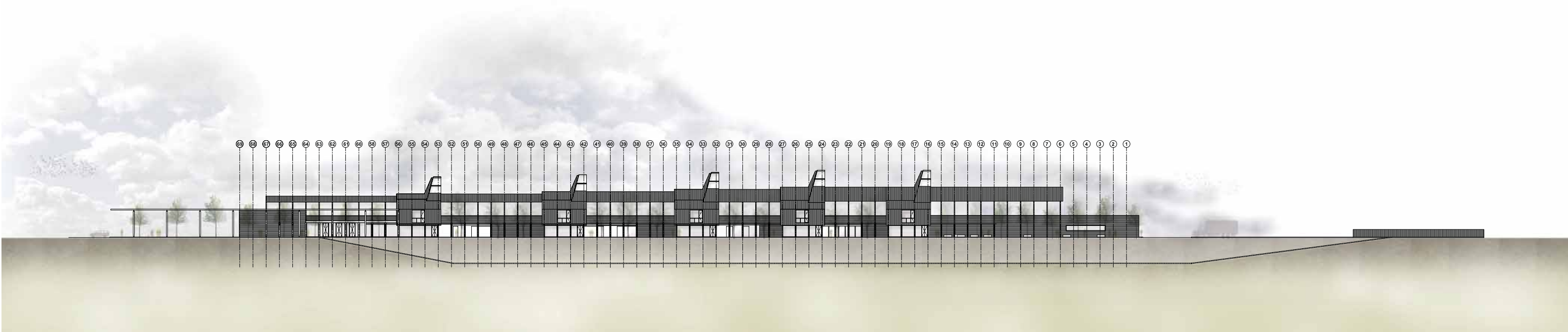

Figure - 11.8 - 3 Dimensional View Looking West - The linear slaughter process runs parallel to the high street, in constant interaction through the output pavilions (By Author).



Figure - 11.9 - 3 Dimensional View Looking North West - The abattoir grows out of the ground, anchored by the heritage on the south (By Author).





Figure - 11.10 - Dimensional View Looking North East - The output pavilions area colour coded according to what is happening inside (By Author).

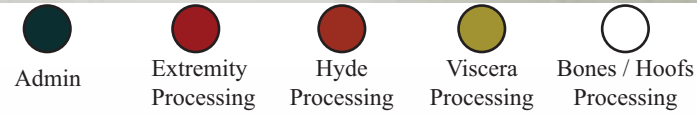

Figure - 11.11 - 3 Dimensional View of the Outdoor Processing and Vendor and Trading Areas on the High Street (By Author).

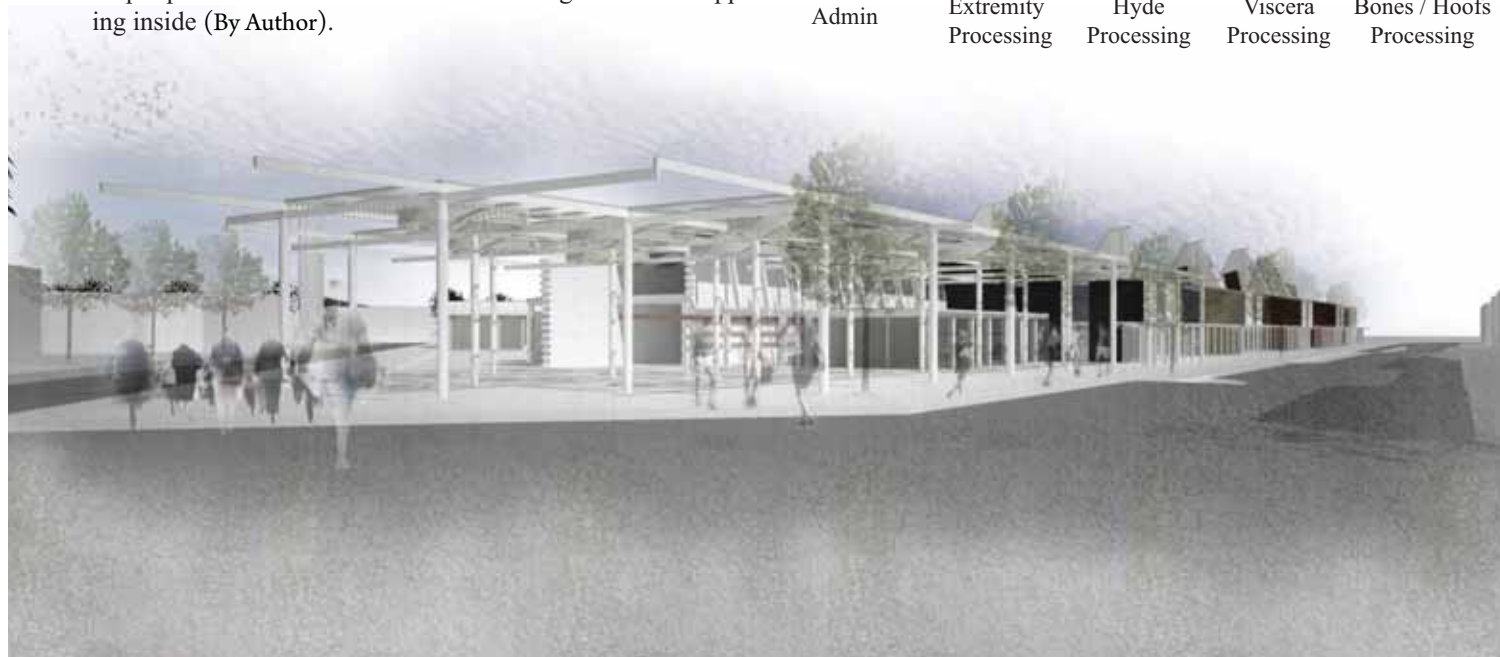

Figure - 11.12 - 3 Dimensional View of the High Street and the Meat Market (By Author).



Figure - 11.13 - 3 Dimensional Interior View of the Lairage Area which is Open for Public viewing to the Top (By Author).



Figure - 11.14 - 3 Dimensional View of the Abattoir Entrance for the employees. From here the Building Grows out of the Ground Establishing another Public plane (By Author).



Figure - 11.15 - 3 Dimensional Interior View of the Processing Spaces with a view Out Onto the Courtyards (By Author).



Figure - 11.16 - 3 Dimensional Interior View of the Slitting Area and Bleeding Pit on the Pit Floor (By Author).



Figure - 11.17 - 3 Dimensional Interior View of the Carcasses coming out of the Hoisting area to the Bleeding Pit (By Author).



Figure - 11.18 - 3 Dimensional Interior View of the Evisceration Area (By Author).

DRAWINGS

234

DETAILS - STEREOTOMY

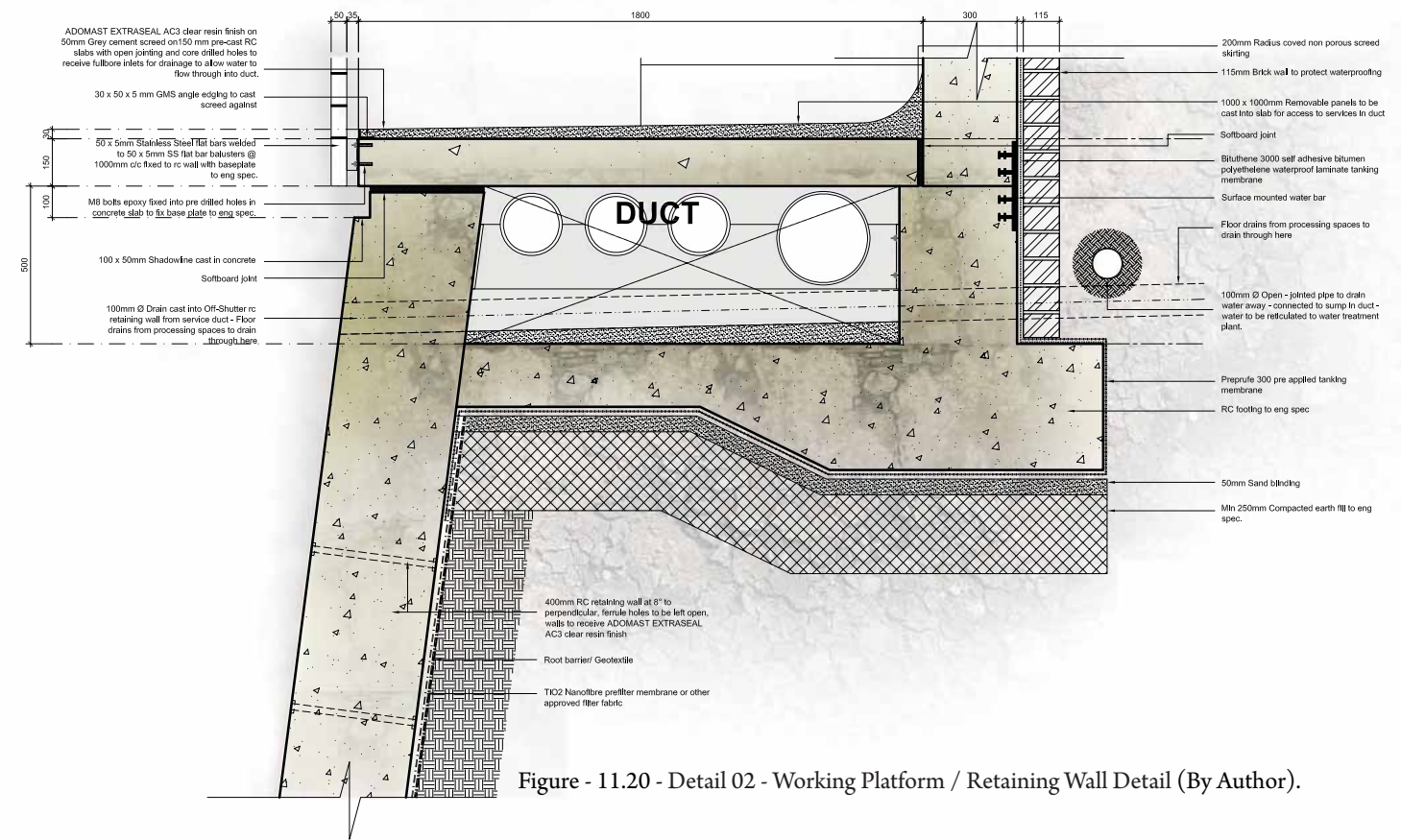

Figure - 11.19 - Detail 01 - Retaining Wall / Footing Detail (By Author).

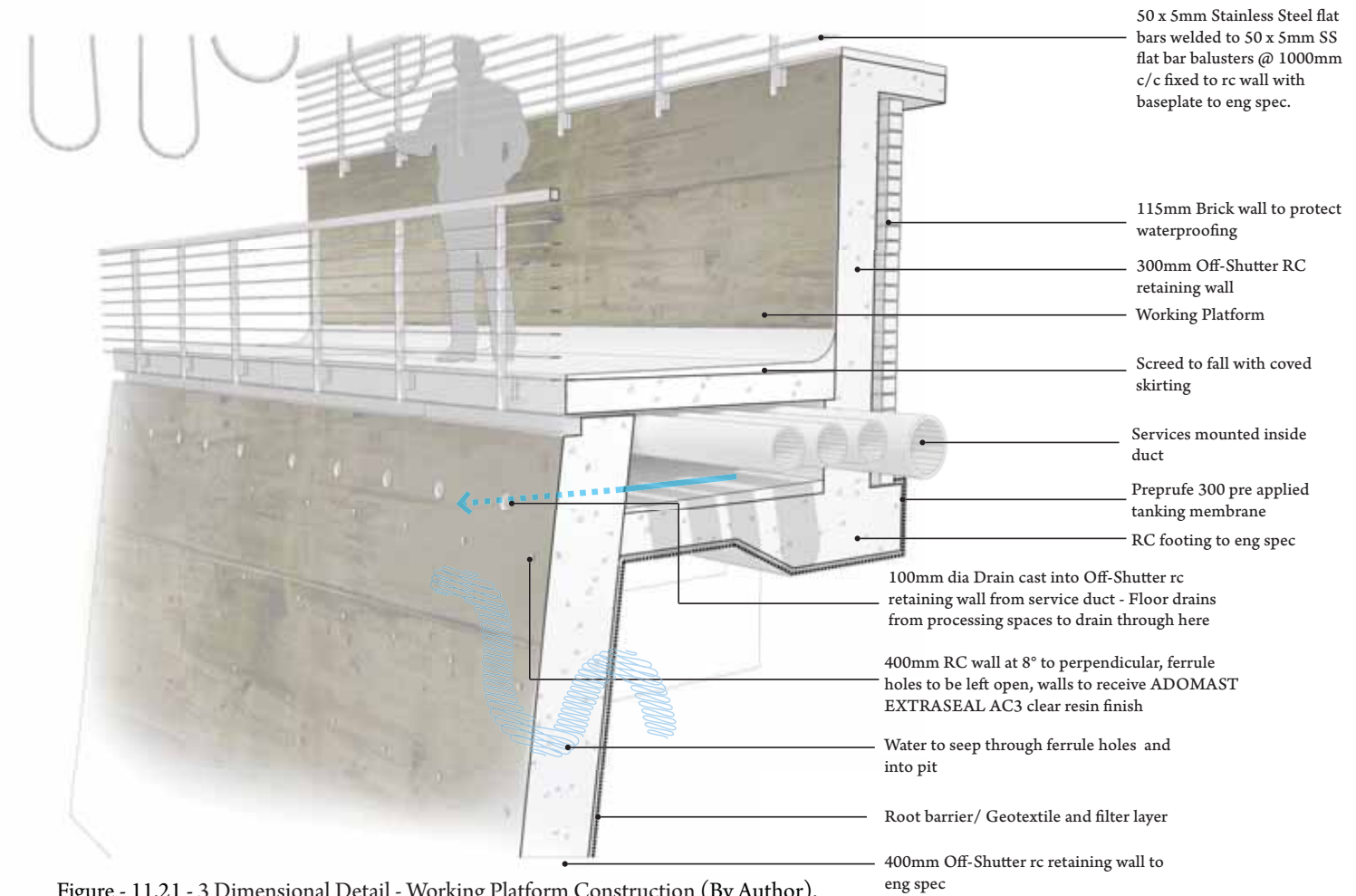
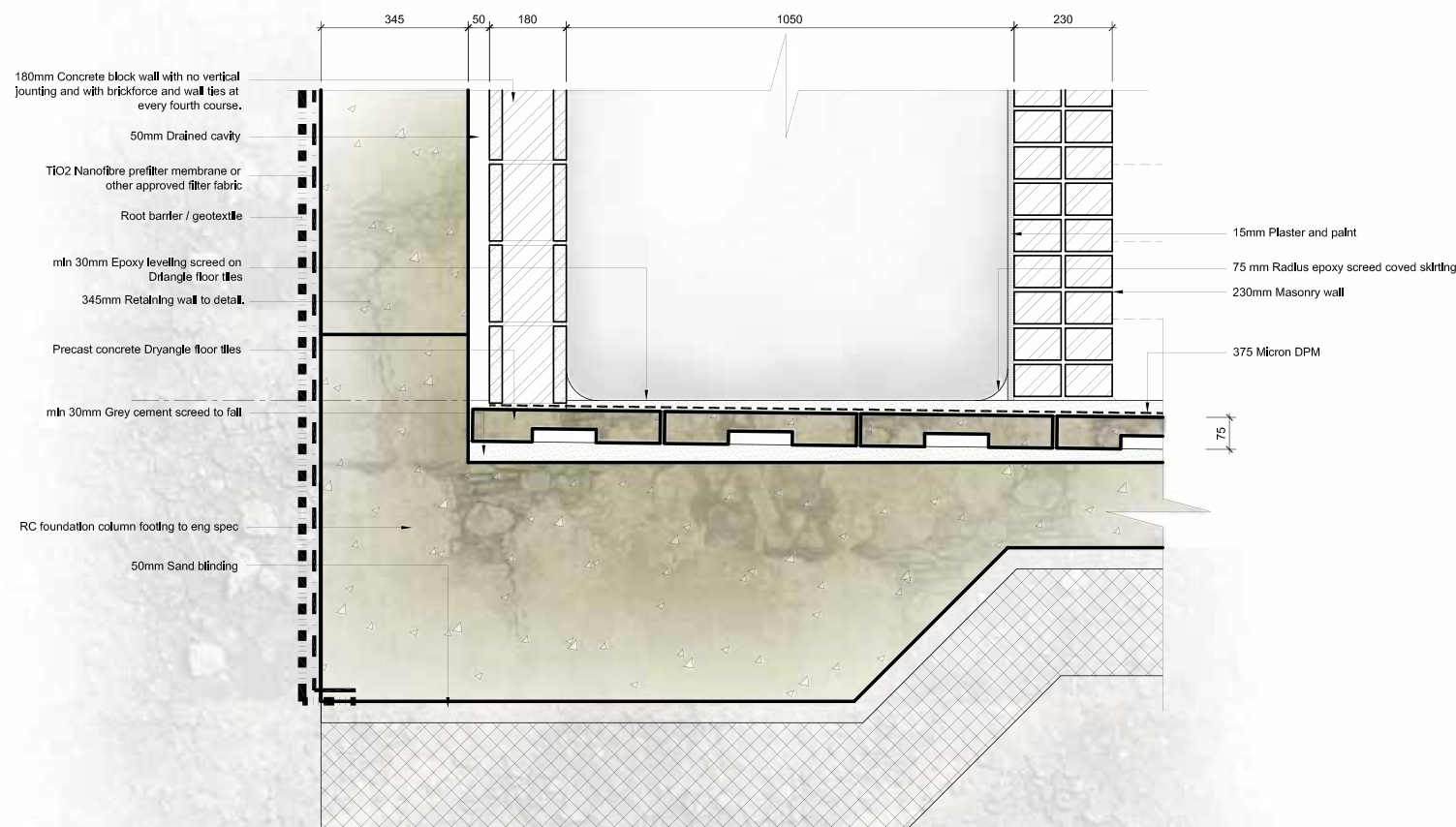
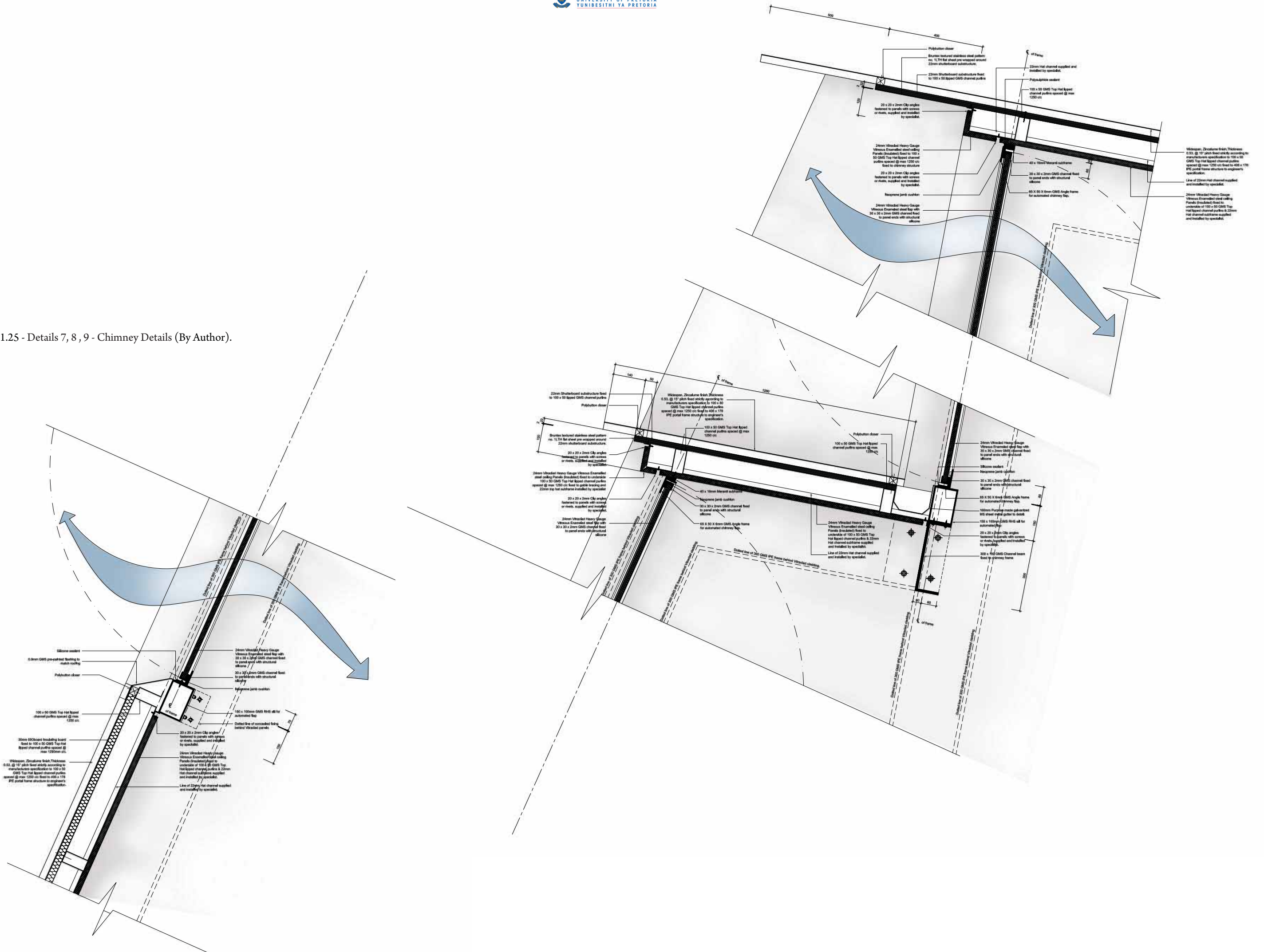
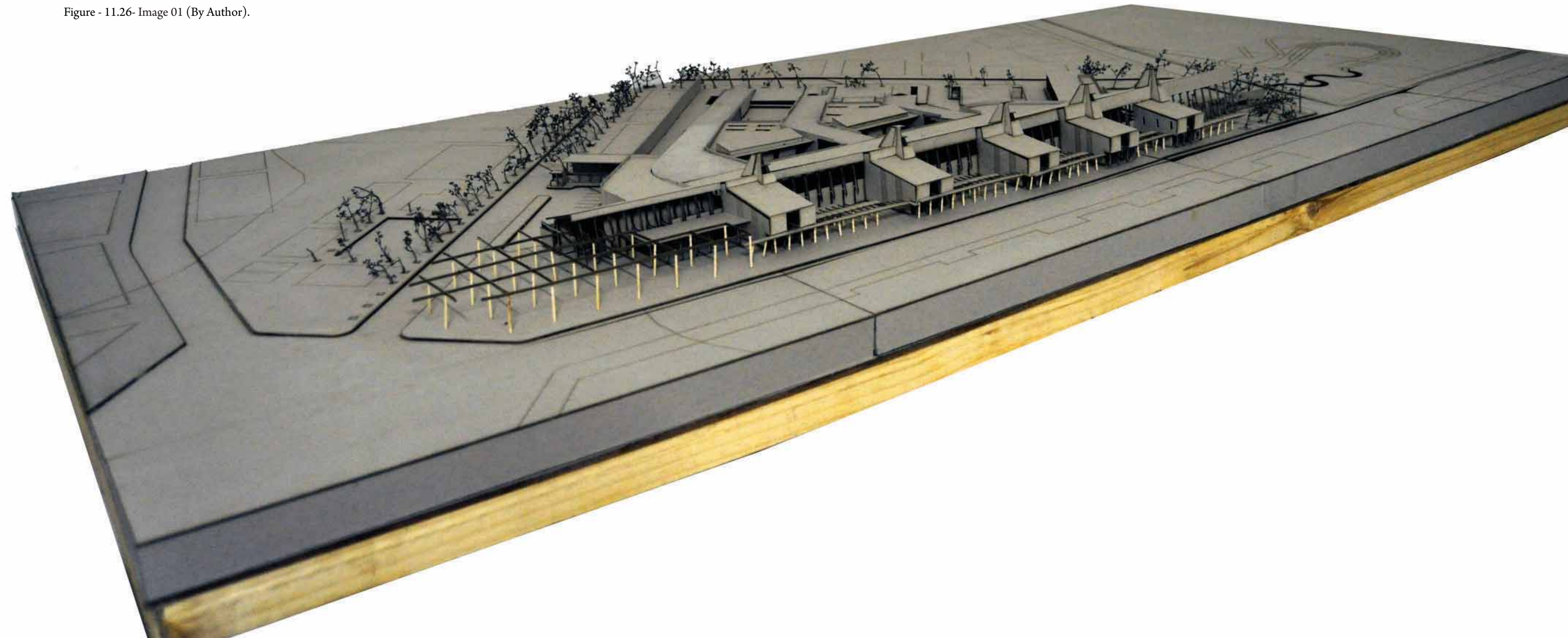

Figure - 11.25 - Details 7, 8, 9 - Chimney Details (By Author).



FINAL MODEL

Figure - 11.26- Image 01 (By Author).



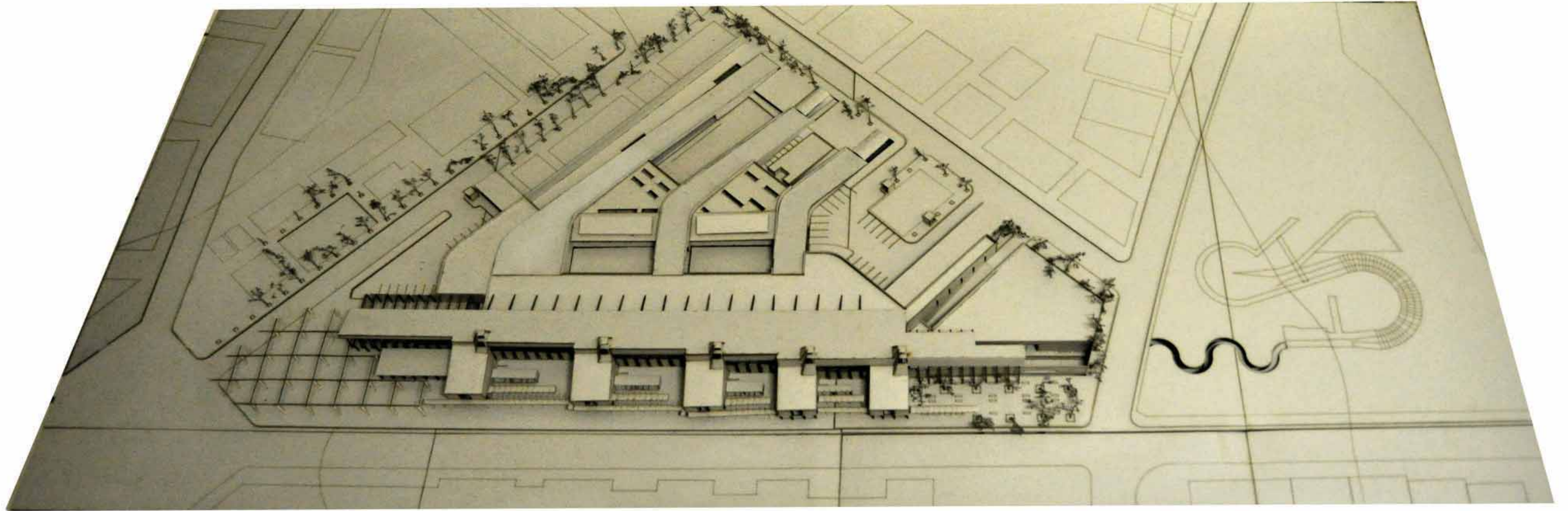

Figure - 11.27- Image 02 (By Author).



Figure - 11.28- Image 03 (By Author).

Figure - 11.29- (Left) Image 04 (By Author).

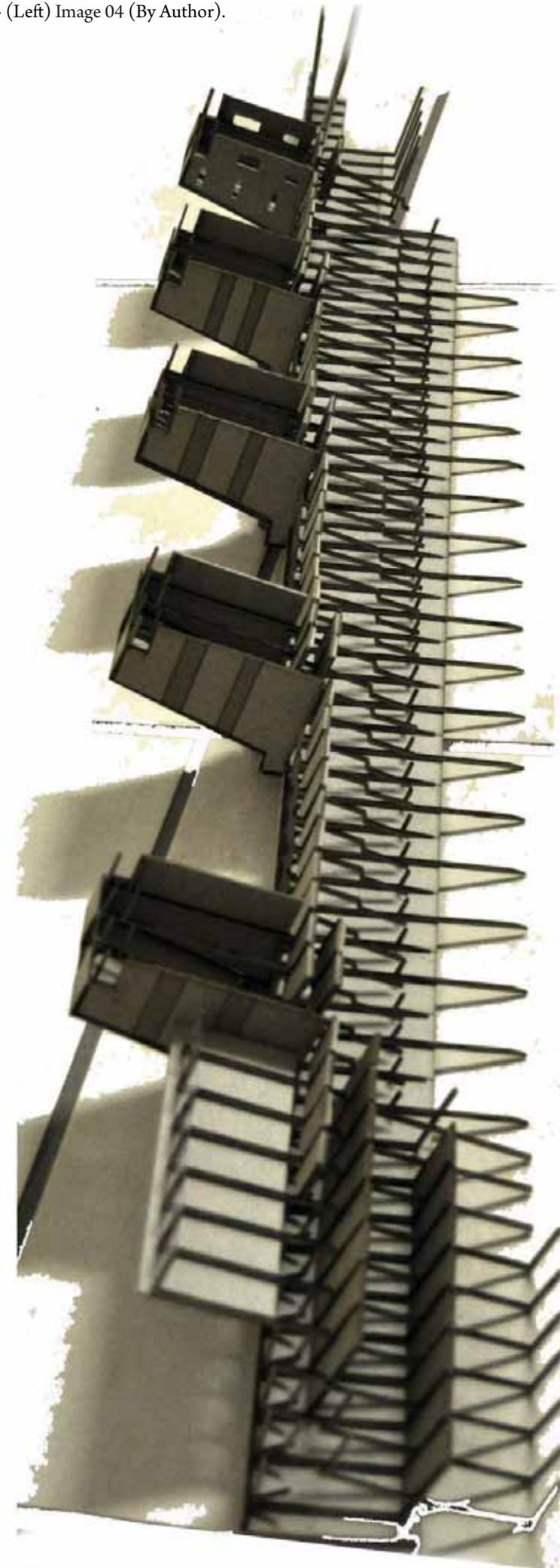
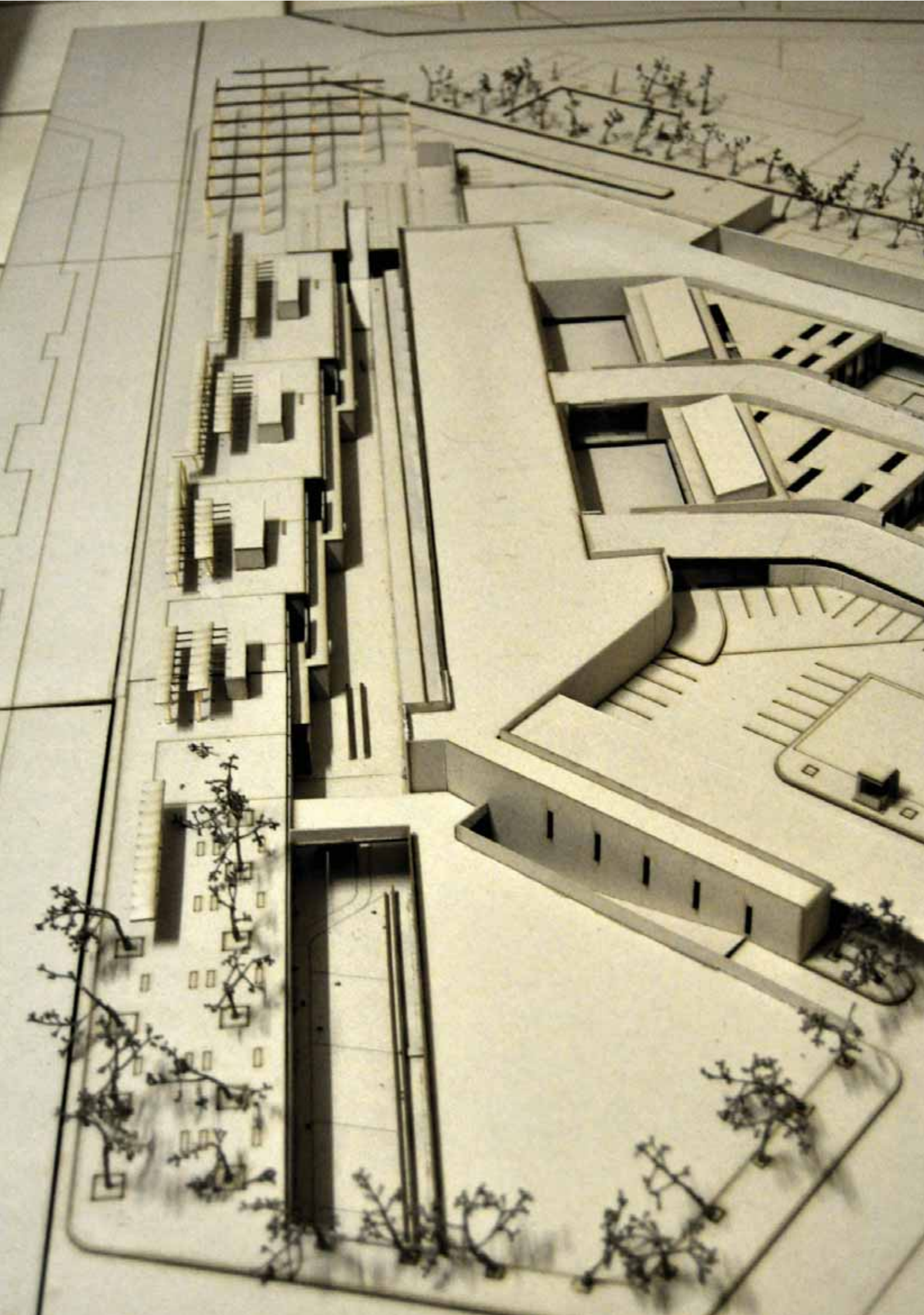

Figure - 11.30 - Image 05 (By Author).

Figure - 11.31 - Image 06 (By Author).

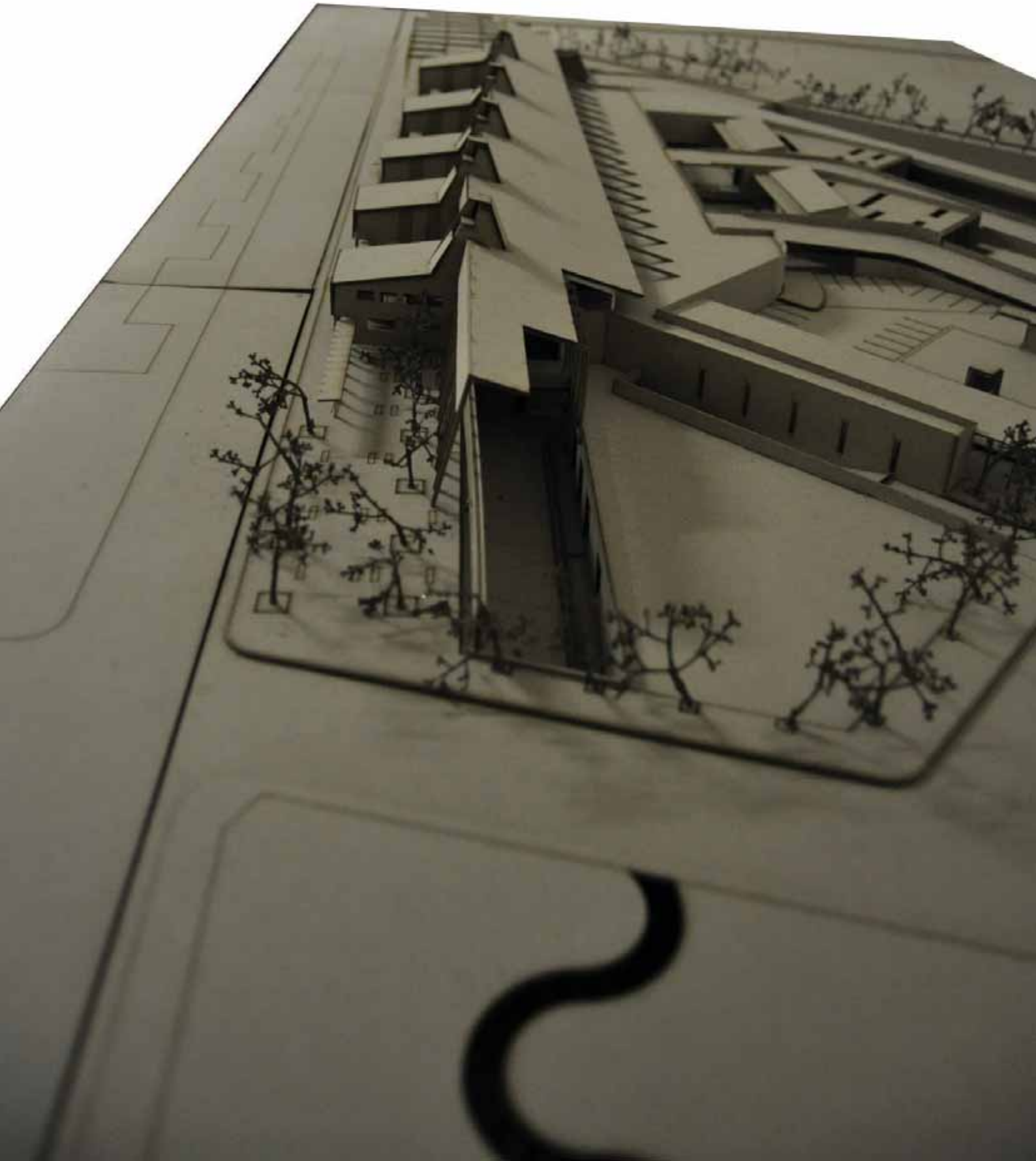

Figure - 11.32 - Image 07 (By Author).





Figure - 11.33 - Image 08 (By Author).

REFERENCES

- Bataille, G. (1997). Slaughterhouse. *Rethinking Architecture: A Reader in Cultural Theory*, 22.
- Breed, C. (2003). *El Proyecto Urbano. Un acercamiento cualitativo para el diseño de la ciudad. El caso de Mamelodi-Este, en Pretoria, Sudáfrica*. Pretoria.
- Breed, C. (2011). Mamelodi Presentation. *Presentation at Boukundé*. Pretoria.
- Burke, P. ([2002], January 11). <http://www.moline.il.us/departments/planning/economic/businessincentives.asp>. Retrieved March 17, 2011, from <http://www.moline.il.us>: <http://www.moline.il.us/departments/planning/economic/businessincentives.asp>
- C. S. Williamson. (2005). *Red meat in the diet*. London: British Nutrition Foundation.
- Cortese, A. D. (2001, August 31). *Education for a Sustainable Future: The Next Industrial Revolution*. Retrieved March 21, 2011
- Curulli, I. (2006). *Industrial Wastelands: Interpreting the urban heritage. History and Memory*. Retrieved February 17, 2011, from www.vgtu.lt: www.vgtu.lt/upload/leid_konf/curulli_industrial.pdf
- Davies, C. ([2000]). *High Tech Architecture*.
- Engler, M. (2004). *Designing America's Waste Landscapes*. Baltimore: John Hopkins University Press.
- Fitzgerald, A. (2010). A Social History of the Slaughterhouse: From Inception to Contemporary Implications. *Human Ecology Review*, 58 - 69.
- Girardet, H. (2010, October). *Regenerative Cities*. Retrieved April 13, 2011, from www.hcu-hamburg.de: www.hcu-hamburg.de
- Goddard, M. (2007, August). *Environmental Considerations in the Design of a New Abattoir at Cranswick Country Foods, Preston, East Yorkshire*. Retrieved April 17, 2011, from Environment Agency: www.environment-agency.gov.uk/static/documents/business/mark_goddard_Cranswick_plc.pdf
- Gold, M. (2004). *Reducing Red MEat Consumption - The Case for Urgent Reform*. Hampshire: Compassion in World Farming Trust.
- Ingels, B. (2009). *Yes Is More*. Copenhagen: Taschen.
- J. Walker, G. v. (1991). *Mamelodi, A Working History*. Pretoria: Human Sciences Research Council.
- Jenkin, D., & Worthington, J. (1996). Making the Recent Past Fit for the Future. London: E & FN Spon.
- Jones, E. (1985). *Industrial Architecture in Britain, 1750 - 1939*. London: BT Batsford.
- Jones, P. (2009, 2009/vol.18). A low Carbon Built Environment. *Indoor and Built Environment Editorial*, pp. 380 - 381.
- Kaye, H. (1978). *The Life and Time of Alois Hugo Nellmapius*. Johannesburg: Macmillan South Africa.
- Kellenberger, C. (2007, October 12). Industrial Architecture in Europe. (Hormann, Interviewer)
- Legenr, M. (2007). *Re Development through Rehabilitation*.
- Littman, J. A. (2009). *Regenerative Architecture*. Massachusetts: University of Massachusetts.
- McCrinkle, C. (2004). *Presentation on Ritual Slaughter in South Africa*. Pretoria: University of Pretoria.
- McDonough, W. & Braungart, M.(2002). *Cradle to Cradle: Remaking the Way We Make Things*. New York: North Point Press.
- Neethling, G. (2008). *The Abattoir's View of the Material Received from the Producer*. Pretoria: Red Meat Abattoir Association.
- Popkin, B. ([2008]). Reducing Meat Consumption Has Multiple Benefits. *Meat Editorial*, 543-545.
- Rifkin, J. (1992). *Beyond Beef: The Rise and Fall of Cattle Culture*. New York: London: Penguin Books.
- Rifkin, J. (2009). *Leading the Way to the Third Industrial Revolution and a New Social*. Retrieved February 24, 2011
- Sen, A. (2004). *Through the Looking Glass: from architecture deserted to architecture revived - industrial architectures passage across time*. Retrieved February 18, 2011, from www.colorsofindia.com: www.colorsofindia.com/ajanta/writings/idus_arch_postfinal_1_8_02.pdf
- Smith, M. (2002). The Ethical Space of the Abattoir: On the (In) Human(e) Slaughter of Other Animals. *Human Ecology Review*, 49-58.
- Stark. (1955). *Pretoria: One Hundered Years*. Pretoria: Unknown.
- Stern, N. (2010, August 13). Retrieved April 13, 2011, from www.LSE.uk: www.LSE.uk
- LSE.uk.
- Stern, N. (2010, August 13). *Key Elements of a Global Deal on Climate Change*. Retrieved April 13, 2011, from www.LSE.uk: www.LSE.uk
- Tschumi, B. (1987). *Bernard Tschumi, disjunctions: Bernard Tschumi, Luca Merlini, Neues National - Theatre Tokio, 1986-1987*. Berlin: Aedes.
- Unknown. (1955). *Pretoria: An Industrial and Commercial Survey*. Pretoria: Felstar Publishing.
- Vialles, N. (1994). *Animal to Edible*. Cambridge: New York: Cambridge University Press.
- Weber, C. (2008). Food-Miles and the Relative Climate Impacts of Food Choices. *Environ. Sci. Technol.*, 36 - 42.
- Williams, N. (2008). Afected Ignorance of Animal Slaughter. *Journal of Agricultural and Environmental Ethics*, 371 - 384.
- Winter, J. (1970). *Industrial Architecture*. London: Studio Vista Limited.