

Chapter 1

Introduction and historical development of Electrochemical Activation

1.1 Water: Introduction

Liquid water is the essential biological solvent of all life processes (Ludemann, 1993). It also represents the continuous phase of all living organisms. However despite being the most abundantly occurring inorganic liquid (Savage, 1993), its familiarity and ubiquitous nature has led to it being regarded as a bland, inert liquid, or a mere space filler for living organisms (Lehninger, 1975). Despite this, most biological molecules of a living organism only function in water, and thus it remains fundamental for the optimal functioning of all life processes (Prilutsky and Bakhir 1997).

A most important consequence of the polar nature of water and of its dynamic capacity for hydrogen bonding (Stumm and Morgan, 1996) is that water is a so-called “*universal solvent*”, and as such is yet another reason why it is indispensable to life itself. Water it is a highly reactive substance, and its ionization products, hydrogen and hydroxide, are important determinants of the characteristic structure and biological properties of proteins and nucleic acids, as well as the interaction with different organic or inorganic intracellular compounds, membranes, ribosome’s and many other cellular components (Lehninger, 1975; Prilutsky and Bakhir, 1997).

1.2 Water: Structure and behavior

As a chemical substance water is unique, and its composition and characteristics have no analogue in nature (Lehninger, 1975). Water is, in fact, considerably more complex than it appears at first sight; an indication of this is the complex configurations displayed by snowflakes. Nevertheless, a very simplified description of water (H₂O) is that it consists of molecules made up of two hydrogen (H) atoms and one oxygen atom (O). Water is capable of existing in a variety of states i.e. crystalline ice (11 variant forms), amorphous ice (non-crystalline), crystalline hydrates (organic and inorganic), liquid water (ordinary, super-cooled and vapour), aqueous solutions (ionic and non-ionic) and as a gaseous state (monomers and

clusters). The strong intermolecular forces in liquid water are caused by the specific distribution of electrons in the water molecule. Each of the two hydrogen atoms shares a pair of electrons with the oxygen atom, this through an overlap of the 1s orbital of the hydrogen atoms with the two hybridized sp^3 orbitals of the oxygen atom (Lehninger, 1975, Stumm and Morgan, 1996). This arrangement of electrons in the water molecule imparts its distinctive electrical asymmetry. The hydrogen atoms have an excess of positive charge and the oxygen atom an excess of negative charge. The highly electron negative oxygen atom tends to withdraw the single electrons from the hydrogen atoms leaving the hydrogen nuclei exposed – hence each hydrogen atom has a local positive charge (δ^+) versus the local negative charge (δ^-) in the unshared orbital of the oxygen atom (Fig 1). Thus while the water molecule has no net charge, it still exists as an electric dipole (Lehninger, 1975, Stumm and Morgan, 1996).

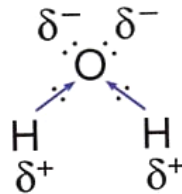

Figure 1. Charge distribution on a water molecule that confers it's the bipolar nature (Schwartz, 1997).

Hydrogen bonding refers to the phenomenon when a unscreened proton attaches to another atom, giving rise to a polarisation of a subsidiary bond much weaker than a covalent bond but stronger than a normal van der Waals force. The two positive protons of the two hydrogen molecules find the negative lone pair electrons of the oxygen and consequently join to produce a co-ordinated cross linked structure of exceptional strength and stability (Fig 2).

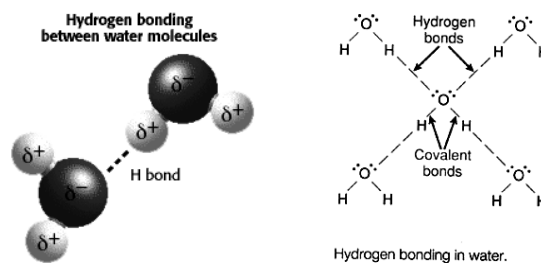

Figure 2. Schematic illustrating the hydrogen bonding associated with the dipolar nature of the constituent atoms (Schwartz, 1997).

When water molecules approach each other, an electrostatic attraction between the partial positive charge of the hydrogen atoms of one water molecule and the partial negative charge of the oxygen atom of the adjacent water molecule arises. The ensuing redistribution of electrical charges gives rise to a complex electrostatic union referred to as a hydrogen bond (Lehninger, 1975; Stryer, 1981). Hydrogen bonds are energetically weak when compared to covalent bonds. Hydrogen bonds in water are estimated to have a bond energy of approximately $18\text{-}20\text{ kcal mol}^{-1}$, compared to the covalent bond energy of $360\text{-}400\text{ kcal mol}^{-1}$ between the H-O atoms (Lehninger, 1975; Stumm and Morgan, 1996). The formation of a single hydrogen bond predisposes to the formation of additional hydrogen bonds between adjacent molecules, and facilitates an enhanced association between all solute molecules. This enhancement of the strength of attraction between two molecules arising from the cooperation of several weak bonds is termed cooperativity. This cooperativity of hydrogen bonding is also a characteristic that confers structure to proteins and nucleic acids. This fact together with geometrical specificity and directionality, endows hydrogen bonds with a greater biological advantage over covalent bonds in biomolecular circumstances (Lehninger, 1975).

Water is conventionally regarded as a 'four-sided' or tetrahedrally co-ordinated lattice of hydrogen bonded water molecules. However its behaviour under the different states of existence means that there is no uniform dictate which governs its structure. The basic characteristics of water structure are related to the maximisation of the number of hydrogen bonds. This is coupled to the repulsive restrictions that other charged molecules will play in determining the resulting geometries and will directly affect the conventional tetrahedrality (Stryer, 1981; Savage, 1993). Due to the tetrahedral arrangement of electrons around the oxygen molecule, each water molecule is theoretically capable of hydrogen bonding with four neighbouring water molecules. It is this electrostatic attraction that confers the distinctive internal cohesion of liquid water. The conventional tetrahedral cluster of 5 water molecules has been determined to be 0.5 nm in diameter (Lehninger, 1975).

With an increase in the temperature of liquid water, there is a parallel increase in the degree of distortion of the hydrogen bonds away from a linear alignment and results in a heightened degree of instability of association. Thus there is a temperature

dependent and by direct implication, a highly dynamic energy driven association, wherein the hydrogen atoms continuously transform their attractive associations by acting as positively charged bridges between the adjacent negatively charged oxygen atoms. For a given energy state this will result in the formation of “clusters” comprising of up to 13-14 water molecules (Lehninger, 1975).

1.3 Water as a solvent

Water is recognised to be a significantly superior solvent when compared to other liquids. Many crystalline salts and ionic compounds readily dissolve in water, and in the case of brine, the sodium chloride molecules readily dissociate into stable hydrated Na^+ and Cl^- ions through the attraction with the water dipoles. Water also opposes the electrostatic attraction between positive and negative ions, and the high dielectric constant, specifically promotes the dissolution of molecular conjugates such as NaCl. The presence of dissolved solutes in a solution changes the structure and electronic properties of liquid water. When a salt such as sodium chloride is dissolved in water, the Na^+ and Cl^- ions become surrounded by shells of water dipoles (Fig 3).

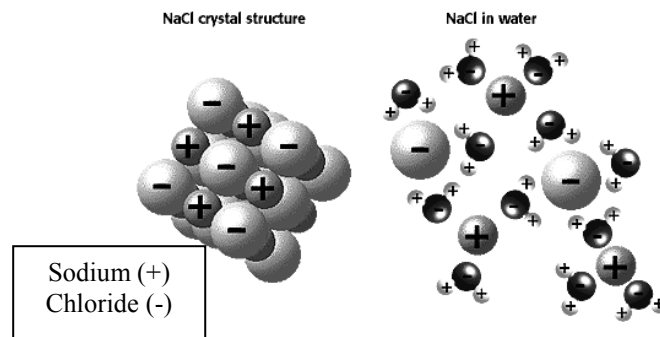

Figure 3. Crystalline manipulations of NaCl in an aqueous solution (Schwartz, 1997)

Within these ion hydrates, the geometry of the water molecules differs substantially from that of the hydrogen bonded water molecules in pure water, and the water molecules become more highly ordered and regular in structure. Dissolved salts display a tendency to disrupt the basic structure of water (Stumm and Morgan, 1996). This has direct thermodynamic implications and the capacity to effect a change in structure is referred to as the ‘Colligative Property’ of water. Depending on the number of solute molecules per unit volume of solvent, the thermodynamic shifts are

characterized by the depression of freezing point, elevation of boiling point and the depression of the vapour pressure. These solute molecules also confer the property of osmotic pressure (Lehninger, 1975; Zubay *et al.*, 1995).

Thus Oxidation Reduction Potential (ORP or REDOX) values of common (non-activated) chemical solutions are determined by the ratio of reduced (Electron-donor) and oxidised (electron-acceptor) chemical conjugates. If the reduced and oxidised forms of a compound are dissolved in distilled water in definite proportions, a readily quantifiable chemical redox pair is formed (Lehninger, 1975). Coupled to this chemical reaction, when a system of different electrodes i.e. platinum and Silver-Chlorine, are immersed in such a solution without any partition in the inter-electrode space, an electric potential is generated. This electric potential will change in a readily predictable stoichiometric manner when the interrelationships of the various redox-pair components are altered by changing the reagent concentrations within the electrolyte medium (Prilutsky and Bakhir, 1997).

1.4 Energetic status of water

Due to their bipolar nature, the 'stable' configuration of water molecules will reflect a balance between the energies of the ubiquitous van der Waals forces of attraction (8-20 kcal mol⁻¹) and those of hydrogen bonding (18.8 kcal mol⁻¹). Since this relationship is energetically biased towards the van der Waals forces, the standard structure of water will thus comprise reduced levels of hydrogen bonded clustering (Wyllie, 1965).

Water has a higher melting point, boiling point, heat of vaporization, heat of fusion, and surface tension than any of its comparable hydrides (H₂S, NH₃). All of these properties are a consequence of the power of attraction between the molecules in the liquid water medium and is a reflection of the state of relatively high internal cohesion. The heat of vaporization is a direct measure of the energy required to overcome the attractive forces between adjacent molecules in the liquid phase so that individual molecules can escape and enter the gaseous phase (Lehninger, 1975). However, the intrinsic energy of molecular association due to van der Waals forces becomes insignificant when substantial external energetic manipulations are applied

to destruct these aggregates of water molecules (Bakhr, 1999). Thus specific electric or equivalent electromagnetic interventions aimed at manipulating this ‘background’ energy of association, produce significant deviations in the behaviour of the water molecules and their tendency to align in predictable geometric patterns.

Under low magnetic simulations, an increase in the presence of water monomolecules has been shown to occur with a concurrent increase in tetrahedrality of alignment and clathrate formation (Kotz and Purcell, 1991). Additionally it has been shown that within a high electric field ($5 \times 10^9 \text{ Vm}^{-1}$), the structures of association alter to the extent that conventional freezing patterns at low temperatures are inhibited (Wyllie, 1965).

Charge and energy may be rapidly transferred between adjacent water molecules and the effects of electronic excitation can be readily described with studies of cluster disassociation and molecular distortion. This has been attributed to the short half-life of the hydrogen bonds i.e. 100 picoseconds or 10^{-11} sec (Lehninger, 1975; Stumm and Morgan, 1996). Any water structure with a predominance of hydrogen bonds will impede chemical reactions due to an increase in viscosity, a reduction in diffusivity and a reduction in the active participation by water molecules. Thus any factor that reduces the quantity of hydrogen bonding as well as the hydrogen bond strength such as electric fields will encourage the overall reactivity of the molecular water (Chaplin, 2007).

‘Transport’ is described as the movement of charge, energy or material in a steady but spatially homogenous situation. The transport of charge through a given structural configuration of water, involves the rapid movement of H_3O^+ and OH^- ions between neighbouring water molecules by means of proton exchange. Protons move rapidly through a coherent sequence of hydrogen bonds by a mechanism of relay charge transfer. This movement of charge creates polarised tracks or energetic defects which repair by means of a relaxation process. Water clusters, even under random arrangements have equal hydrogen bonding in all directions. Contact with metallic electrodes at even low voltages has a distinctive effect on the orientation of water molecules and the positioning of ions (Chaplin, 2007).

In low density electromagnetic fields, the translational and rotational motions of the water molecules are reduced, and the reduction in the van der Waals attractive forces strengthen the hydrogen bonds resulting in the water molecules becoming more tightly bound. This in turn influences the solubility of the water and results in an increase in the concentration of dissolved gases and hydrophobic molecules at the contact surfaces. The increase in solution reactivity is ascribed to the evolution of singlet oxygen ($^1\text{O}_2$), free radical formation eg. $\text{OH}\cdot$, and specific phase changes as evidenced by the production of flattish surface nanocavities or nanobubbles (Chaplin, 2007).

These changes result in significantly durable effects, and substantiate claims of a so-called ‘memory effect’. The manipulation of water structure by electric fields to produce metastable clathrates has also been reported, as well as the paradoxical increase in surface tension due to the relative increase in hydrogen bonding (Zenin, 1999; Chaplin, 2007). Due to the fine balance between the conflicting hydrogen bonding and non-bonded interactions within water clusters, any weakening of the van der Waals forces leads to a strengthening of the hydrogen bonding with greater cyclic hydrogen bonded clustering. This phenomenon has been supported by the increase in the melting point of the water which arises from a greater ordering and lower entropy of the manipulated water in the magnetic field (Chaplin, 2007).

1.5 Electrolysis

1.5.1. History of Electrolysis

In 1832, Michael Faraday introduced the principle of electrolysis and postulated the laws that govern the passage of electric current through an aqueous salt solution (Shirahata *et al.*, 1997). This law states that the weight of a given element liberated at an electrode is directly proportional to the quantity of electricity that is passed through the solution (Kotz and Purcell, 1991). The first patent for the electrolytic manufacture of chlorine was submitted by Charles Watt in 1851, and the first commercial production of chlorine by electrolysis was commissioned in Germany in 1890 (White, 1992).

1.5.2 Energy of Electrolysis

While conventional electrochemistry describes the ability to generate an electric current from chemical reactions, electrolysis describes the use of an electric current to bring about a chemical change in the electrolyte (Kotz and Purcell, 1991).

In terms of basic description, an electrolytic cell consists of a pair of inert electrodes in contact with a solution of brine in a liquid state, where the ions are dissociated and free to move. The connection of the electrodes to an external source of electrical current creates an 'electron pump', which causes one of the electrodes to become negatively charged. Monovalent cationic sodium ions are attracted to this negative electrode, and become reduced when electrons from the electrode are accepted. This reducing action at the electrode results in it becoming the cathode.

The current source simultaneously draws electrons from the other electrode giving it a net positive electrical charge. Chloride anions are attracted to this electrode where they surrender electrons to become oxidised. This reaction results in this electrode becoming the anode (Kotz and Purcell, 1991). Oxidation occurs when an atom, ion or molecule releases electrons and becomes oxidised. Conversely reduction occurs when an atom, ion or molecule gains electrons, thus becoming reduced. Thermodynamically there are no free electrons, and thus every oxidation reaction must be accompanied by a corresponding reduction (Stumm and Morgan, 1996). Thus a reducing agent donates electrons, whereas an oxidising agent receives or scavenges electrons. The reaction can be summarised as follows:

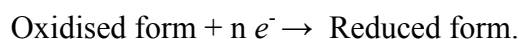

Electrons generated at the site of oxidation, the anode, are driven or pushed towards the cathode by an electromotive force or *emf*. This force is directly proportional to the difference in energy between the two electrodes and also reflects upon the reactivity and concentration of the electrolyte solution (Lehninger, 1975).

For a given energy (charge) differential between the two electrodes in an electrolysis system, there is an equivalent potential accorded to the electrolytic cell which is

termed the cell potential or E . Under standard conditions i.e. concentration and pressure, this potential is referred to as the ‘standard cell potential’ and is designated as E^o . Thus the potential produced by an electrolytic cell is the sum of all potentials of the oxidising and reducing half-reactions in the system.

The standard free energy (G^o) of an oxidation-reduction reaction is proportional to the cell potential under standard conditions and the relationship is governed by the following equation:

$$\Delta G^o = - nFE^o$$

where n refers to the number of electrons transferred between oxidising and reducing agents and F is the Faraday constant (9.64853×10^4 coulombs/mole of electrons).

Additionally, this change in free energy (ΔG^o) in an oxidation-reduction reaction under standard conditions is directly proportional to the cell potential, and under conditions where the redox reaction of the cell is balanced, the relationship can be formulated to describe the Nernst equation, namely:

$$E = E^o - \frac{RT}{nF} \ln Q$$

where R is the gas constant, T is the temperature (Kelvin), Q is the reaction quotient ($\frac{[\text{oxidants}]}{[\text{reductants}]}$), F is the Faraday constant and n , is the number of electrons transferred between the oxidising and reducing agents in a balanced redox equation (Stumm and Morgan, 1996).

The Nernst equation thus permits the theoretical calculation of the voltage produced by an electrolytic cell or conversely describes the concentrations of oxidising or reducing agents present for a given energy input. This equates to the REDOX potential that is produced when the voltage applied across the cell is known. From a biological perspective, the Nernst equation describes the relationship between the voltage across a semi-permeable membrane and the ion concentration in the compartments on either side of the membrane. The equation provides a simple method for testing the status of the electronic equilibrium of solutes across the membrane system (Sperelakis, 1995). The number of moles of electrons consumed or

produced in a redox reaction is obtained by measuring the current flowing in the external electric circuit at a given time.

It is also possible to quantify the charge in terms of the number of electrons that comprise the electrochemical reaction. This equates to the charge carried by one mole of electrons and equals 1 Faraday (F) where:

$$1 \text{ F} = (1.602177 \times 10^{-19} \text{ coulombs/electron})(6.02214 \times 10^{23} \text{ electrons/mol}) \\ = 9.64853 \times 10^4 \text{ coulombs/mol (= Faraday's constant).}$$

Based on the relationship between charge, current and time, the charge can be calculated by multiplying the current and the time of the reaction. By combining the chemistry of the redox reactions with the calculated energy input of the system, one is able to establish the measure of the electrochemical activation of the electrolytes in the system (Kotz & Purcell, 1991). Thus from a theoretical perspective, there is a direct relationship between the relative concentrations of the oxidising or reducing agents that are produced when the voltage applied across the cell is known and when the redox reaction is balanced.

1.5.3 Chemistry of Electrolysis

Conventional electrochemistry is founded on the following reaction.



The reaction of the brine solution at the Anode would comprise:

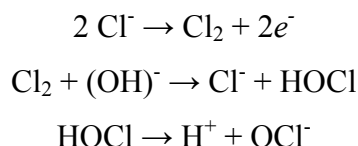

Correspondingly and simultaneously, the reaction at the Cathode would be:

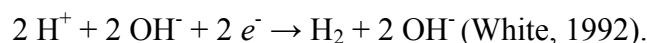

However it has long been shown under practical conditions, that this premise does not hold true and the best description of the chemistry that occurs during electrolysis of aqueous NaCl is the following:

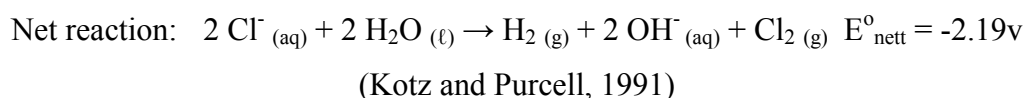
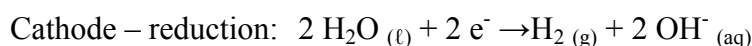
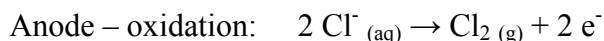

It is imperative to acknowledge that the ions of sodium and chloride in an electrolytic reaction do not act in isolation, and that they represent only one dimension of the electrolyte solution. Thus instead of dismissing the role of the water as a mere background filler or inert solvent, the evaluation of the composite electrolytic reaction must encompass the decisive role played by the dissociation of the individual water molecules and the constituent ions when considering definitive calculations of electrolytic reactions. The anomalous behaviour of the ions in the electrolysis cell can be explained by the mismatch between the conventional quantitative calculations and the actual reaction speed or kinetics of the various reactions that occur within the system.

This anomalous behaviour has been termed the ‘over-potential’ and is particularly well demonstrated with the electrolytic reduction of water:

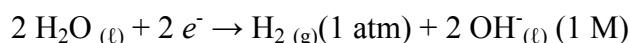

This reaction has a calculated potential of $E^{\circ} = -0.83\text{V}$, however the measured reaction occurs at an even more negative potential value $\sim -1.4\text{V}$ (Kotz and Purcell, 1991). Recognition of this anomaly contributes substantially to the understanding of the phenomenon of the Electro-Chemical Activation (ECA) of water as advanced in the first reports by the inventor (Prilutsky and Bakhir, 1997; Bakhir 1999).

1.5.4 Conventional Brine electrolysis

The ideal electrochemical cell consists of an Anode and a cathode and a separating partition where the separator permits selective migration of ions between the chambers (Kotz and Purcell, 1991).

Commercially chlorine is produced by the electrolysis of a concentrated sodium chloride solution. When dissolved in water, the dissociated chloride anions are oxidised at the anode to form chlorine gas, while the water molecules are reduced at the cathode to form hydroxyl anions and hydrogen gas. The sodium ions in solution react with the hydroxyl ions to produce sodium hydroxide (Bakhir and Zadoroznhy, 1999^a; Bommaraju *et al.*, 2007).

Chlorine is produced electrolytically using three basic types of reactor cells. These comprise the mercury type, diaphragm type and membrane based cells. The main difference between the different reactor types is the manner by which the chlorine gas and the sodium hydroxide are prevented from admixing in order to ensure the generation of products of high purity (Bommaraju *et al.*, 2007). In mercury based cells there is no physical separator, and the electrolytic process requires that the mercury itself, acts as a separator. Conversely, in diaphragm cells, the partitioning of the electrolysis products is due to a material separator which may be either asbestos or an equivalent polymer-modified coating of the cathode. In membrane type cells, the separating partition is usually made of an ion-exchange membrane (Fig 4) (Curlin *et al.*, 1991). While all earlier cells made use of carbon based anodes, modern anodes are made with standardised and dimensionally stable electrodes which are titanium based and coated with a layer of specific platinum group metal (PGM) oxides designed to optimally catalyse the electrolytic reaction and limit corrosion (Diao *et al.*, 2004). The cathode is typically steel in diaphragm cells, nickel in membrane cells, and mercury in mercury cells (Curlin *et al.*, 1991).

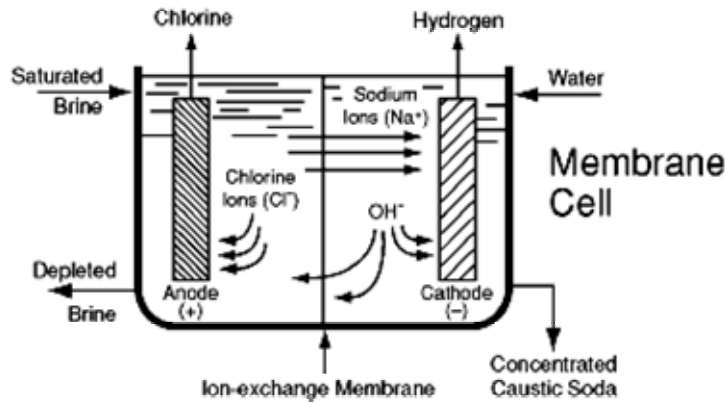

Figure 4. Schematic of a conventional membrane based electrolytic cell (Curlin *et al.*, 1991).

In a membrane type cell, the acid based ion-exchange membrane is sandwiched between the anode and cathode plates. Electrolysis of the saturated brine solution fed into the anodal compartment results in the evolution of chlorine gas at the anode, while the cationic sodium ions migrate through the membrane into the cathodal compartment (Curlin *et al.*, 1991). In contrast to the diaphragm type cells, only water and sodium ions pass through the membrane, and the unreacted sodium chloride remains in the anolyte. The sodium ions within the cathode chamber react with the hydroxyl ions generated by the dissociation of the water and results in the formation of sodium hydroxide, caustic soda or “caustic” which is extracted from the cathodal chamber. As a direct consequence of the water dissociation, the solution becomes saturated with hydrogen gas.

A further variation of basic cell type is employed for Sodium hypochlorite or “bleach” production. These reactor cells electrolyse dilute brine solutions and comprise an anode and cathode without a separating diaphragm or membrane (Bommaraju *et al.*, 2007). The anodic and cathodic reactions are equivalent to that of a chlor-alkali cell and the main difference is that the pH of the electrolyte in the cell is maintained in the range of 10 to 12. Under these conditions, the chlorine generated at the anode reacts with sodium hydroxide to form sodium hypochlorite (NaOCl). This cell type is functionally inefficient in that only low concentrations of bleach are produced as the hypochlorite is readily reduced at the cathode to reform into chloride. Additionally, when the electrolyte becomes acidic, the hypochlorite can also react further to form chlorate (Bommaraju *et al.*, 2007).

1.5.5 Electrochemical Activation (ECA) of water

1.5.5.1 History of Electro-Chemical Activation

Thirty years prior to the publication by Michael Faraday of the laws of electrolysis (1832), Petrov described the evolution of electrolytic gases from a high powered galvanic cell. In addition, by introducing a porous diaphragm between the electrodes, he was able to harvest separate products from the anodal and cathodal compartments, and termed these solutions anolyte and catholyte respectively (Prilutsky and Bakhir, 1997).

It is reported that between 1960 and 1973, Korovin conducted a variety of experiments into the behaviour of water in an electrostatic field and reported on a series of effects that had previously not been described. He referred to a process of “water energisation” wherein “charged water was able to stimulate the activity of living matter and in this manner enhanced the resistance to disease” (Prilutsky and Bakhir, 1997). In Japan, Suwa was reported to have designed a diaphragm type electrolyser capable of producing separate Anolyte and Catholyte solutions from water as far back as 1952. These reports led to the creation of the terms “Live and Dead” water, which regrettably eventuated in a series of spurious and technologically unsubstantiated commercial fads (Prilutsky and Bakhir, 1997).

In 1972, Bakhir formally introduced the process of “ElectroChemical Activation (ECA) of water”, where anolyte and catholyte solutions generated from water of low-mineralisation, were found to display physicochemical parameters and reactivities which were substantially distinct from the models that were governed by the classical laws of electrolysis. These anomalous findings arose from studies conducted into the use of electrochemical methods to modify the properties of drilling solutions for use in oil and gas exploration whilst working at the Tashkent Scientific Research Institute of Natural gas, USSR Ministry of Gas industry (Leonov, 1997).

The term ‘Electro-Chemical Activation’ was officially coined by Vitold Bakhir in 1975 (Tomolov, 2002).

1.5.5.2 Principles of ElectroChemical Activation (ECA) of water

“There is no progress without paradox” - *Niels Bohr* (Drost-Hansen, 1965).

In contrast to conventional electrochemical systems where chemical reactions always take place at the electrode surfaces, and where the chemical composition of the electrolyte in direct contact with the anode and cathode will be subject to predictable alterations, the objective of the Electro-Chemical activation (ECA) of water is to subject the entire volume of liquid in the inter-electrode space to an electric field of the maximum possible intensity, with the minimum chemical exposure possible and with a minimum of heat emission.

The primary limitation of this approach is that the maximum electro-physical effect can only be ensured in the immediate vicinity of the electrode surface i.e the electric-double-layer (EDL) (Bakhr, 1999) The EDL is comprised of one layer attached to the electrode surface and the other which is distributed diffusively in the contact liquid (Stumm and Morgan, 1996). Vicinal water refers to interfacial water i.e. that which is in contact with a solid interface, the properties of which differ from the adjacent bulk water due to the structural differences induced by the proximity to the (electrode) surface. These interfacial anomalies fall outside of established physicochemical ranges, and have historically been described in terms of variations in the temperature of the electrolyte at the electrode surface. These anomalous changes to the properties of vicinal water are fundamentally independent of ion-dipole or dipole-dipole interactions, and are highly energetic and exist regardless of the specific surface interactions (Drost-Hansen, 1965).

These anomalous modifications to the water structure decay progressively with increasing distance from the electrode surface, and have a characteristic decay length of the order of one to a few nanometers i.e. 4-10 water molecule diameters (Drost-Hansen, 1965). Thus the capacity to effect a substantive energetic change to the properties of the water volume in the inter-electrode space is constrained by the magnitude of the Electric-Double-Layer or the volume of vicinal water immediately adjacent to the electrode and the surface charge density or electric potential at the surface (Stumm and Morgan, 1996).

During the ElectroChemical Activation (ECA) of a dilute brine based solution, the following changes are postulated to occur when contrasted against conventional electrochemical models.

Reaction at the Anodal surface:

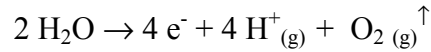

The Anolyte would be acidic and oxygen gas would be evolved.

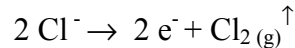

Chlorine gas would evolve, and a number of highly active oxidants would be formed.



The resultant oxidant solution has a pH of <2 and an ORP of ~1150 mV. It is highly oxidising with potent biocidal properties.

The corresponding electrolysis of brine at the Cathode would be:

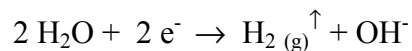

Hydrogen gas would be evolved, the solution would become alkaline, and a number of highly active reductants would be produced.

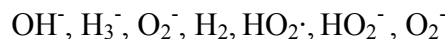

The resultant catholyte solution has a high pH of > 11.5 and a REDOX of ~ -800mV. It is a highly reducing solution with high adsorption and catalytic capabilities, as well as having surfactant and enhanced wetting properties (Bakhir, 1999). This reaction scheme concurs with the report which details an abundance of dissolved hydrogen in the alkaline cathodal solutions, and a predominance of dissolved oxygen in the acidic anodal water (Shirahata, *et al.*, 1997, Hsu, 2005).

Thus the synthesis of ECA solutions are proposed to only be possible where the unipolar electrochemical exposure of electrolyte solutions is combined with the passage of continuous microvolumes of electrolyte solution through a high voltage field of the electric double layer at the electrode surface (Leonov, 1997). To this end, distinctive electrochemical reactor designs have proven necessary to achieve this objective and these have been refined to optimise the electrolytic dissociation of the water molecule over that of conventional electrochemical processes.

The ‘classic’ ECA cell comprises a co-axial alignment of electrodes, and the ratio of the relative dimensions of the electrodes ensures an equivalent average electrolyte flow velocity through each partitioned chamber. This unique design facilitates the optimal contact of the maximum possible number of electrolyte microvolumes within the EDL at the electrode surface. The formation of the ‘new’ highly-reduced or highly-oxidised compounds, free radicals and other reactive molecules occurs within the EDL where the gradient of the electrical field will achieve a potential difference of several million volts per centimetre measure of distance from the electrode surface (Prilutsky and Bakhir, 1997). The qualified presence of these short-lived, energy rich intermediate products with high bacteriocidal capability has been reported by Diao *et al.* (2004).

The historical inability to produce a repeatable unipolar electroactivation outcome, as well as the difficulty to quantify the degree of activation from a purely theoretical perspective, has given rise to the intermediary term of “activation contribution”. While incomplete, it serves to define the difference between the physical and chemical parameters of the activated solution immediately after electrochemical exposure, from that which follows the cessation of the relaxation process (Bakhir, 1999). The key to understanding the nature of the ECA process and the creation of transient “metastable” states within the dilute salt solutions, are the changes that arise direct as a result of this unipolar electrochemical exposure.

The phenomenon of electrochemical activation was originally advanced as a result of studying the reactional properties of potable drinking water when subjected to activation in a diaphragm type electrochemical reactor. Given that water does not exist in an ideally pure state in nature, the intrinsic mineralisation may vary considerably both in terms of quality and quantity. Additionally, gases such as oxygen, hydrogen and nitrogen are also dissolved in water. The properties of the water that are produced by Electrochemical Activation are directly dependent upon the composition of the mineral salts of the source water, the type and regimen of electrochemical exposure, and more specifically the design of the electrochemical reactor unit.

Cathodic treatment results in the electrolyte water acquiring an alkaline reactivity due to the dissolved salts which dissociate to form hydroxides. As a consequence, the REDOX decreases, the surface tension falls, the content of dissolved oxygen and nitrogen is reduced, and the concentration of the hydrogen and hydroxyl groups increases. The electric conductivity decreases primarily due to the transformation of heavy metals which precipitate out of solution as insoluble hydroxides (Prilutsky and Bakhir, 1997). Conversely, anodic treatment results in a marked acidity and an increase in REDOX due to the formation of both stable and unstable acids. These include sulphuric, hydrochloric, hypochlorous and persulphuric acids, as well as hydrogen peroxide, peroxosulphates, peroxocarbonates, chloroxy-compounds and their intermediate compounds. In addition, there is a corresponding decrease in the surface tension and an increase in electrical conductivity of the solutions (Prilutsky and Bakhir, 1997; Bakhir, 1999, Hsu, 2005).

Since the degree of water dissociation is negligible, the activity of hydrogen ions in water is thus equivalent to their concentration in solution. This concurs with the anomalous behaviour of dilute electrolyte solutions during electrolysis, wherein the water molecules themselves are acknowledged to contribute to the reactive 'solute' component of a dilute electrolyte solution (Bakhir, 1999).

The REDOX is a measure of the behaviour of electrons or "electron pressure" in a water solution (Stumm and Morgan, 1996). It is measured by a high-ohmic millivoltmeter and accurate assessment requires that a pair of electrodes be used, one of which is the reference electrode i.e. silver chloride (AgCl), while the other is the measuring electrode, which is made from a platinum group metal. There is a distinctive relationship between REDOX and pH, wherein a change in the pH of drinking water by 1 unit by the addition of either sodium hydroxide or hydrochloric acid produces a corresponding change in the REDOX of approximately 59mV i.e. REDOX increases when pH falls and decreases when pH rises (Bakhir, 1999). The exaggerated shifts in REDOX during electrochemical activation of ultrapure water confirm the distinctive differences between theoretical acid-base chemistry and the shifts associated with electrolytic reactions. Nernst also reported on these anomalous reactions where it was found that lower electron activity was associated with an increased REDOX, and where a higher electron potential led to a reduced REDOX

(Bakhr, 1999). It is thus evident that both Anolyte and Catholyte manifest substantial relaxation alterations in terms of REDOX relative to that of the changes observed in the classical chemical models. In the latter, there is near complete parity between the measured and the theoretically calculated values. Conversely, the relaxation changes following electroactivation amounted to deviations of 43 and 100% for the Anolyte and Catholyte solutions respectively following ECA treatment (Fig 5).

	ANOLYTE	CATHOLYTE	HCl	NaOH
		pH - 7.3 ORP: +270mV	1 Drinking Water	
Immediate	pH: 3.03 ORP: + 1040mV ORPt*: + 545mV	2 pH: 11.8 ORP: -830mV ORPt: +18mV	3 pH: 3.2 ORP: +595mV ORPt +545mV	pH: 11.8 ORP: +25mV ORPt: + 18mV
24 hours 1 Day	4 pH: 3.1 ORP: +1010mV	pH: 10.2 ORP: -650mV	pH: 3.01 ORP: 590mV	pH: 11.7 ORP: +20mV
168 hours 7 Days	5 pH: 3.3 ORP: + 590mV	pH: 9.5 ORP: -0mV	pH: 3.02 ORP: +585mV	pH: 11.8 ORP: +20mV
Difference	6 pH: 0.27 ORP: 450mV	pH: 2.3 ORP: 830mV	pH: 0.18 ORP: 10mV	pH: 0 ORP: 5mV

Legend: ORP (REDOX) – Oxidation Reduction Potential, 1 –raw tap water; 2 - freshly generated anolyte and catholyte of dilute saline and tap water; 3 – tap water buffered by hydrochloric acid and sodium hydroxide respectively as direct analogs of electrochemically activated water (control); ORPt* - theoretical redox potential calculated from the Nernst equation; 4 – solution parameters after 24 hours, 5 – solution parameters after 7 days, 6 – changes in parameters over 7 days. (adapted from Bakhr, 1999).

Figure 5. Changes in physicochemical parameters between electrochemically activated brine solutions and their equivalent chemical analogs over time.

When oxygen is bubbled through a dilute hydrochloric acid and water solution at a rate of 100 litres of gas per litre of solution, an increase in REDOX of up to 100mV has been recorded. Conversely, hydrogen gas bubbled through a sodium hydroxide solution, resulted in the generation of a reducing REDOX of –350mV from an initial source solution of 0mV (Chaplin, 2007). This fundamental experiment substantiates the hypothesis that the development of the mismatched pH and REDOX values that

are integral to the ECA process are not mediated by conventional chemical means alone. It is also important to note that increased mineralisation of the source water reduces the magnitude of the relaxation of the pH and REDOX parameters. This phenomenon is confirmed by Hsu (2003, 2005) who reported that high concentrations of salt in the brine feedstock solution resulted in reduced REDOX levels relative to that of dilute brine solutions. The optimum relaxation phenomenon is generated with a brine solution of between 0,1 and 1g/l NaCl, and the amplitude of relaxation deviation decreases when the degree of mineralisation falls below 0,1g/l or rises above 1g/l (Prilutsky and Bakhir, 1997; Bakhir, 1999).

1.5.5.3 Relaxation

According to the classic thermodynamic definition, relaxation is the gradual transition of a system from an unbalanced state arising from the direct effects of external factors, to that of a state of thermodynamic equilibrium. Relaxation is an irreversible process, and due to the thermodynamic laws governing Entropy and Enthalpy, these changes should be associated with the dissipation of the energy as heat (Tomolov, 2002). Under conventional physico-chemical considerations, heating results in the destruction of water aggregates with a direct increase in the relative concentration of water mono-molecules as well as a solution which displays substantially enhanced chemically reactivity. Heat transferred into or out of a system at constant pressure is defined as Enthalpy. The change in energy of a reaction has been determined to be directly proportional to the overall quantity of reagents present. Hence the energy required to produce the change of phase of water has been detailed as follows:

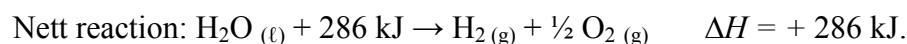
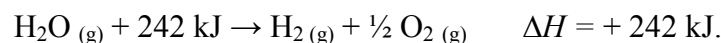
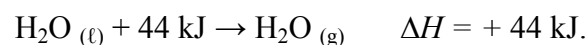

Thus 286 kJ are required for the endothermic decomposition of 1 mol of liquid water to its gaseous elements (Kotz and Purcell, 1991), and this equates to the energy input

required for the production of steam as would be relied upon for microbial inactivation.

The non-reagent based alteration of the properties of water wherein it acquires anomalous reactional abilities and attributes has been described as “the decomposition of water” with electricity, and results in the physico-chemical modification of the water medium. The term for this change has been coined as ‘water de-structurisation’ (Bakhr, 1999).

From an energetic perspective, the ECA process has been described as a “series of electrochemical and electro-physical impacts upon water molecules, ions and molecules of the dissolved solutes, under conditions of minimum heat emission, wherein the area of volume charge near the electrode surface of an electrochemical system, results in a non-equilibrium transfer of charge across the electrode: electrolyte interface” (Bakhr, 1999).

Equilibrium is achieved by two processes. The first stage equilibrium is attained only within the micro-volumes of water that comprise the activated solution. The second stage equilibrium is described by a slower relaxation, wherein the physical and chemical parameters reach stationary values which are largely determined by the conditions of equilibrium associated with a standard environment (i.e. STP). This relaxation is directly proportional to the size of the system i.e. the volume of electrochemically activated water, and the slower second phase relaxation processes will encompass such phenomena such as changes in viscosity, diffusion, heat conduction, electrical conductivity, catalytic activity, Oxidation-reduction balance, pH and surface tension (Bakhr, 1999).

A co-ordinate plot of ORP against pH of a standard acid-base manipulation of ORP versus an ECA induced shift highlights the exaggerated range of ORP values which can be achieved with electroactivation (Fig 6).

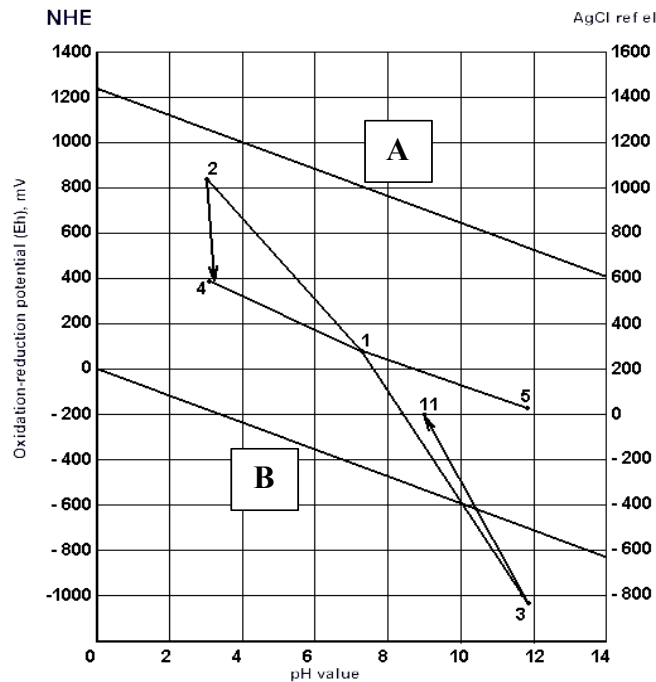

Legend: A – Upper range of thermodynamic stability of water, B – Lower range thermodynamic stability of water, 1→2 = Anodal activation, 1→4 = water buffered with acid, 1→3 = Cathodal activation, 1→5 = water buffered with alkali, 2→4 = Anolyte relaxation, 3→11 = Catholyte relaxation.

Figure 6. Co-ordinate plots of the pH and REDOX values of water as a result of both chemical and electrochemical manipulation of their physicochemical properties and the changes as a result of relaxation (Bakhr, 1999).

Thus it has been shown that ECA solutions are neither stable nor constant over time, and it is proposed that during “relaxation”, that the reactive properties of the anolyte and catholyte solutions will revert spontaneously with a substantial change in energetic state to the corresponding physico-chemical state of their theoretical chemical analogues (Tomolov, 2002).

The similarity between measured and theoretical REDOX values of solutions generated by a plate based reactor as reported by Liao *et al.*, (2007) further substantiates the differences between the latter and the coaxial based FEM design (fig 8), and reaffirms the contention that not all electrolysed oxidizing solutions are the same (Sampson and Muir, 2002)

1.5.5.4 ECA Reactor design

As opposed to conventional electrolytic cells which are designed for selective and concentrated chemical production, the ECA technology is based upon the generation of meta-stable, aqueous based, anolyte and catholyte solutions which display anomalous physico-chemical and catalytic activity. These solutions can only be considered to be in an Electrochemically activated state when the magnitude of the anomalous properties, primarily exaggerated Oxidation-Reduction Potential (REDOX/ORP), are capable of spontaneous reversion to the classical thermodynamic equilibrium which characterise the equivalent, non-activated reagent solutions. The functional integrity and efficiency of the ECA technology thus depends on the consistent unipolar electrolysis of brine solutions of specifically low mineralization. The pure products of ECA electrolysis are not commercially available as distinct chemical reagents, and in the process of the “electrolytic decomposition of water”, molecules and compounds are formed which don’t exist outside of the electrochemically activated water (Bakhir and Zadorozhny, 1999^b).

The properties of the electrochemically activated anolyte and catholyte solutions are dependent upon a number of factors which include the solution flow rate through the reactor, the current applied, temperature, the degree of recirculation of solution between the cathodal and anodal chambers, and fundamentally, the degree of mineralisation of the feed water itself. Water of varying, but low degrees of mineralisation is passed through a specifically configured electrochemical cell known as a Flow Electrochemical Module (FEM) or Flow Electrochemical Reactor (RFE). The ECA cell is typically 210mm long with a diameter of 16mm, and comprises a co-axial alignment of the electrodes. It is comprised of a central rod or anode (positive electrode) which is manufactured from titanium and coated with a variety of platinum group metal oxides including ruthenium and iridium (Fig 8) (Bakhir *et al.*, 1999; Zinkevich *et al.*, 2000)

The anode is inserted into an outer coaxial tube or sleeve which acts as the cathode (negative electrode). The Cathode can be manufactured from a variety of metal types, but the most common is stainless steel. The two electrode chambers are partitioned with a zirconium-aluminium ceramic membrane of low filtration capacity

to prevent admixture of the anodal and cathodal solutions (Figs 8 and 9), and has a capacity to withstand trans-membrane pressures of 1 atmosphere. This is the core for the ion-selective partitioning in the reactor cell. The resulting anodal and cathodal chambers are effectively isolated with elastic sealing rings and non-conducting dielectric fittings which house the inlet and outlet ports, and which in turn control the fluid flow dynamics through the separate chambers (Fig 10) (Bakhr *et al.*, 1999; Bakhr and Zadorozhny, 1999^a; Marais and Brözel, 1999; Marais, 2000; Zinkevich *et al.*, 2000; Guentzel *et al.*, 2008).

While a variety of prototypal variations have evolved since the first reports of the ECA process (Fig 7), the current commercial reactor used in the various studies of this report, represents the third generation of design and is referred to as the FEM 3 (Fig 8). In contrast to the classical membrane type cell (saturated brine and anodal feed), hypotonic saline is fed into the cathodal chamber of the FEM 3 reactor and exits from the same as catholyte (Figs 8 and 9). The porosity of the membrane permits the unimpeded flow of the saline from the cathodal into the anodal chamber, and anolyte will be generated and harvested concurrently. Dissociated cationic ions are partitioned within the cathodal chamber, and their conjugate anions will be selectively retained within the anodal chamber, this due primarily to the electrical charge gradient that is established between the two electrodes (Bakhr *et al.*, 1999). Under the abovementioned production conditions, the two separately harvested electrochemically activated solutions display exaggerated physicochemical parameters i.e. either maximally acidic or alkaline pH, with markedly elevated oxidising or reducing REDOX values respectively. However, due to the specific hydrodynamic features of the different chambers, as well as the design of the solution reticulation system outside of the reactor, a portion of the catholyte effluent may be redirected as an additional influent stream into the anodal chamber. This incremental redirection of the catholyte stream into the anodal chamber, results in a progressive pH shift of the effluent anolyte stream from acidic towards neutral. Alkaline anolyte will be produced when the bulk of the catholyte stream is redirected into the anodal chamber. Thus, the customisation of the specific physico-chemical parameters of the anolyte solution is predominantly achieved by adjusting the proportion of the catholyte stream which is redirected into the anodal chamber.

Sectional View

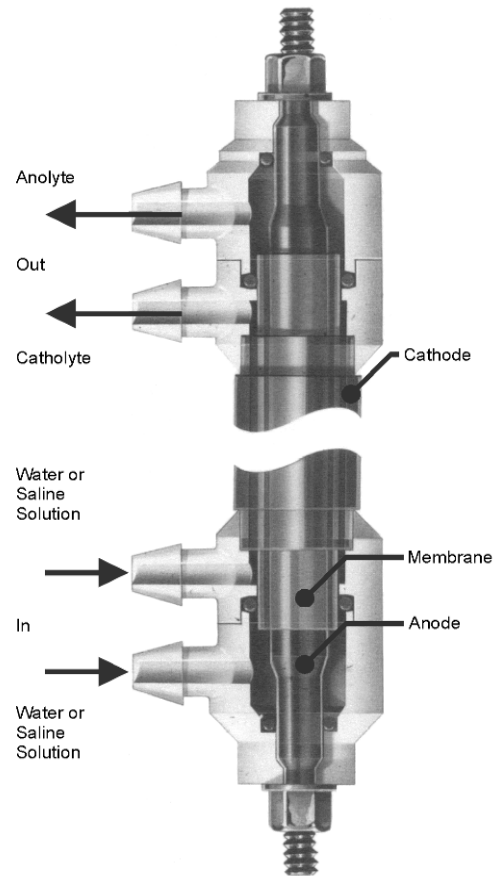
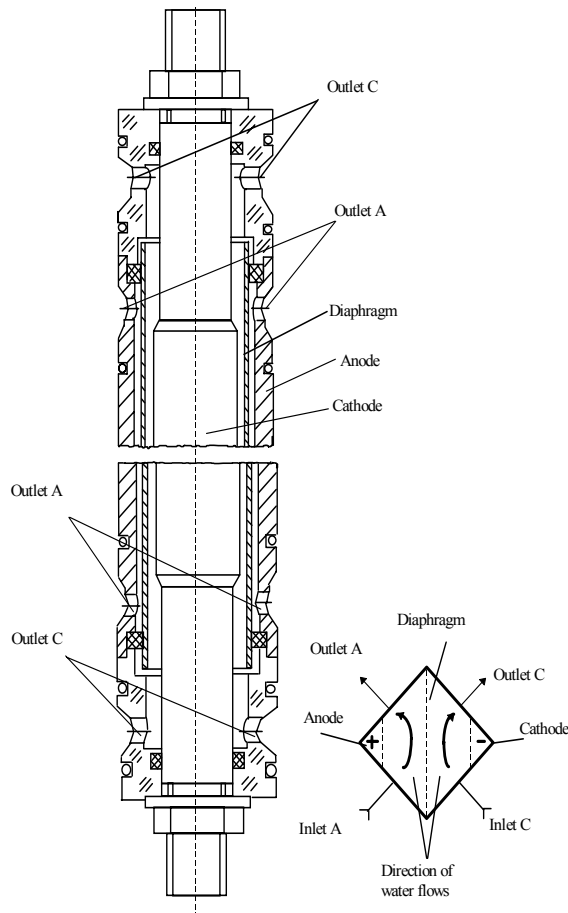

Figure 7. Design and components of FEM 2.
Note External Anode (Bakhir, 1997)

Figure 8. Design and components of FEM 3.
Note External Cathode (Bakhir, 1999)

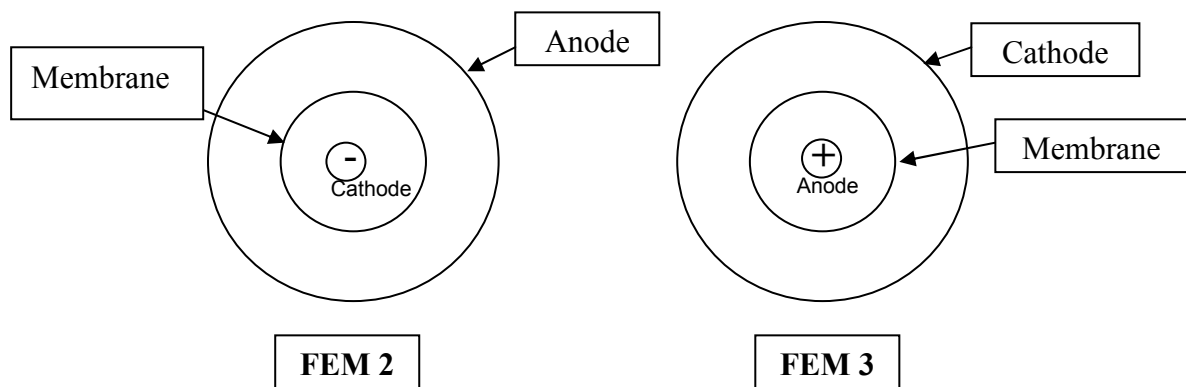

Figure 9. Cross sectional schematic of the different FEM designs describing the co-axial configuration of the electrodes and the differences between the two types of FEM reactor (Rowe, 2001).

Additional adjustments to the quality of the anolyte solution can be effected by changing amongst others, the intra-reactor chamber pressures, degree of mineralization of the feed solution, specific type of the catalytic salt reagent, influent saline feed temperatures and reactor flow rates (Hsu, 2005). While the changes in REDOX described an inverse relationship to the flow rate through the reactor, the magnitude of the REDOX shift was shown to be independent of the salt concentration of the feed solution. Conversely, the quantity of total residual chlorine formed during the reaction was directly related to the degree of salinity of the influent solution as well as the flow rate through the reactor (Hsu, 2005).

The range of electrolysis efficiency from 23-51% as measured by the reduction rate of chloride ions has been shown to be dependent on both the solution flow rate through the reactor and the salt concentration in the feed solution. Increases in both variables resulted in a substantial reduction in electrolysis efficiency (Hsu, 2003). Further manipulations to the process, such as the double activation of the anolyte solution can be achieved by feeding anolyte as opposed to saline or catholyte solution into the anodal chamber of the terminal reactor.

Thus a variety of hydraulic configurations are possible, all of which are designed to achieve specific objectives. The specific assembly and hydraulic configuration of the reactors within a generating system will dictate the specific type of solution that will be generated. Solutions can thus be tailored and optimised for distinctive or unique applications.

1.5.5.5 Physical and chemical activities of ECA solutions

Based on studies of ECA solutions generated using different types of electrolysis reactors, a number of theoretical postulates have been forwarded regarding the properties of ECA solutions.

Three distinct groups of features have been proposed to describe the distinctive physical and chemical characteristics of anolyte and catholyte solutions. These comprise:

- 1) Stable products of classical electrochemical reactions, i.e stable acids and bases,
- 2) Highly reactive unstable products including free radicals, with a half life of up to several hours, and
- 3) Longer-lasting quasi-stable structures which are formed in association with the electric field adjacent to the electrodes' surface, which either exist as free structural complexes or as hydrated membranes of ions, molecules, radicals and atoms (Prilutsky and Bakhir, 1997).

The determinants of the first group influence the pH value of the electrolyte and confer the acid and alkaline properties of the ECA solutions. Aqueous acids and their conjugate bases are the most versatile and universal catalysts of organic reactions and specific acid-base catalysis is defined as the rate enhancements which are proportional to the relative concentrations of H^+ and OH^- ions respectively (Lehninger, 1975).

The factors of the second group enhance the oxidant and reducing properties of the solutions. These comprise highly reactive and unstable products, including free radicals and other active ion species, having a typical lifetime of less than 48 hours. Included here would be electrically and chemically active micro-bubbles of electrolytic gases, 0.2 - 0.5 μm in size, at concentrations up to $10^7 ml^{-1}$ distributed uniformly throughout the solution. This phenomenon accords with the reported response of pure water to a low density electromagnetic field, wherein an increase in the concentration of dissolved gases and an increased reactivity due to singlet oxygen (1O_2) and free radical formation (eg. $OH\cdot$) have been described (Chaplin, 2007). The presence of dissolved gases – hydrogen in the cathodal chamber and oxygen in the anodal chamber have also been independently confirmed by Shirahata *et al.* (1997), Hanaoka (2001), Hsu (2005) and Stan *et al.* (2005).

The factors of the third group are said to comprise quasi-stable structures. These are structures formed at or near the electrode surfaces as a consequence of the very high voltage drop ($\sim 10^6$ volts/cm) at the electrode:electrolyte interface. This charge differential is proposed to result in the modification of the energetic interfaces between the interacting atomic and molecular components of the solution and will result in the formation of free standing structural complexes of hydrated membranes

or flat surface nanobubbles which will form around the dissolved ions and molecules (Chaplin, 2007). As a consequence of the previously proposed ‘de-structurisation’, the size of these water clusters will be reduced from 10-13 to approximately 5-6 molecules per cluster (Bakhir, 1999). This feature relates to a shift away from hydrogen bonding and has been confirmed with Molecular Dynamic Light Scattering studies (Chernikov *et al.*, 1999). All of these features are proposed to contribute to the catalytic and biocatalytic properties of the water. Hanoaka (2001) has reported on the paradoxically protracted potentiation of superoxide dismutation activity when the reductant solution was combined with commercial antioxidants. Despite having no intrinsic Catalase or SOD-like activity, the catholyte still retained exaggerated antioxidant properties and this phenomenon is attributed to the extremely stable dissociation activity of water after electrolysis. The second and third group of factors are proposed to be unique to the production conditions of electrochemical synthesis. Additionally it is proposed that the replication of this effect would not be feasible under classical physical or chemical procedures (Bakhir, 1999).

1.5.5.6 Effect of Mineralisation on ECA solutions

The abovementioned product classes are proposed to be categorised as follows:

- 1 : stable chemical compounds, acids and bases,
- 2 : unstable / metastable highly active species,
- 3 : structural anomalies of water.

The relative contributions of mineralization to the different classes of activation products are described as in Table 1.

Table 1. Proportionate roles of the different reactive product categories arising from ECA solutions of varying mineralisation (Prilutsky and Bakhir, 1997).

Water Type	Mineralisation (g/l)	Relative Role
Ultra fresh	<0.3	3 > 2 > 1
Fresh	0.3 – 1.0	3 ≥ 2 > 1
Hypotonic saline	1.0 - 3	3 = 2 ≥ 1
Saline	3 - 10	3 < 2 ≤ 1
Hypertonic saline	>10	3 ≤ 2 ≤ 1

From the above it is evident that in order to promote the generation of highly reactive unstable and metastable species, the electrical conductivity and hence the mineralisation (salt concentration) of the non-activated electrolyte solution must be kept below 3g/l. During the electrolysis of a strongly hypertonic saline solution, the substantial shifts in the pH and ORP values can be equated directly to that of conventional electrochemical syntheses wherein large quantities of concentrated acids or alkalis i.e. chlorine, sodium hypochlorite and sodium hydroxide respectively, are formed (Leonov, 1997; Bommaraju *et al.*, 2007).

When simplified, the main processes that may theoretically occur in an ECA reactor with a low mineralisation electrolyte can be expressed in the following way:

- 1) oxidation of water at the anode: $2\text{H}_2\text{O} - 4e^- \rightarrow 4\text{H}^+ + \text{O}_2$;
- 2) reduction of water at the cathode: $2\text{H}_2\text{O} + 2e^- \rightarrow \text{H}_2 + 2\text{OH}^-$;
- 3) formation of gaseous chlorine in chloride solutions at the anode: $2\text{Cl}^- - 2e^- \rightarrow \text{Cl}_2$;
- 4) formation of highly active oxidants in the anodic chamber: Cl_2O , ClO_2 , ClO^- , HClO , Cl^\cdot , O_2^\cdot , O_3 , HO_2 , OH^\cdot ;
- 5) formation of highly active reductants in the cathodic chamber: OH^- , $\text{H}_3^\cdot\text{O}_2^-$, H_2 , HO_2^\cdot , HO_2^- , O_2^- (Bakhr, 1999).

The creation of high concentrations of reactive oxidant species and free radicals in the anodal chamber results in a solution with marked biocidal properties. Simultaneously, the enhanced reduction in the cathodal chamber generates a saturated solution of reductants with properties of distinctive adsorption and detergent capacity (Bakhr, 1999, Hennion, 2006; Hsu, 2006).

While Suzuki *et al.* (2002) report on the presence of both hydrogen peroxide and hydroxyl radical in acidic EO water using Electron Spin Resonance (ESR) spectroscopy, more recent investigations into the generation of hydroxyl and superoxide radicals in electrolyzed water solutions failed to confirm the generation of either of the two reactive oxidant species using ESR. While the authors acknowledge that the chemistry between 5,5-Dimethyl-1-pyrroline-N-Oxide and the ECA solutions is unknown, their studies also failed to confirm the presence of chlorine dioxide in

freshly electroactivated brine solutions (Stan and Daeschel, 2005; Stan *et al.*, 2005). It is important to note that it is unknown what reactor design was used in the generation of the solutions, and it has been confirmed that reactor design and operational parameters will substantially influence the quality and constituents of the electroactivated solution produced (Sampson and Muir, 2002).

When the solutions of anolyte and catholyte are generated from brines of different mineralization levels, there are substantial shifts in both pH and REDOX levels. When the pH value of the anolyte solution is acidified, the REDOX correspondingly shifts to an elevated positive (oxidant) value, and conversely when the catholyte pH is increased, the REDOX is progressively reduced to an increasingly negative (reductant) value. When the pH and REDOX of non-activated aqueous solutions of common chemical reagents and water are measured, the parameters are distributed in a range from pH=0–12.5 and REDOX from (–100) to 700 mV depending on the type of electrode couple employed.

By way of an example, the following extremes of pH and REDOX values can be generated with solutions of chemical reagents under laboratory conditions:

1. Concentrated sulfuric acid: pH=0.3; ORP = + 680 mV, CSE;
2. Saturated KOH solution: pH=12.3; ORP = –60, mV; CSE;
3. Saturated chloride of lime solution $\text{Ca}(\text{ClO})_2$: pH=11.5; ORP=750 mV, CSE.

(CSE– Chloride: Silver electrode as the reference electrode) (Prilutsky and Bakhir, 1999).

It is recognized that when the concentrated reagent solution is progressively diluted with water, the pH of the solution will gradually approach the pH value of the diluent. This shift in pH value is associated with an equivalent regression in the Oxidation-Reduction potential, and this covariant relationship equates to approximately 60 mV for every unit of pH change. Thus when an acid is diluted with distilled water and the pH value of the solution increases by 1.0, then the expected reduction in REDOX will be 60 mV. Conversely, when an alkali is diluted with water, a 1 unit increase in pH

will correspond to an increase in the REDOX by 60 mV (Prilutsky and Bakhir, 1997; Bakhir, 1999). Thus there is a direct relationship between the changes in the REDOX of a solution for each unit change in the pH scale, and the plot of these covariant parameters on a coordinate system describes a linear relationship.

The distribution of pH and REDOX covariants of different compounds can be described according to the following categories:

- solutions of chemically pure inorganic compounds in distilled water without electrochemical treatment (marked as \cdot (1))
- solutions of chemically pure organic substances in distilled water without electrochemical treatment (marked as \bullet (2)), and
- ECA-solutions derived from a range of solutions from ultra-fresh water through to a concentrated saline solution, produced by unipolar electrochemical anodic or cathodic treatment (marked as $^{\circ}$ (3)) (Fig 12).

The parallel dotted line represents the correlation corridor for pH:REDOX covariants of inorganic compounds in solution. The area described by contour line 2 represents the conjugate pH:REDOX values for the solutions of organic compounds, and the area described by contour line 3 describes the distribution of pH:REDOX covariants measured in a variety of different ECA solutions (Prilutsky and Bakhir, 1997).

With progressive refinement of the design of the FEM, new generations of electrolytic cells have made it possible to consistently achieve unipolar (anodic or cathodic) activation of water with low levels of mineralisation (0.01-0.2g/l). Under these conditions, it has been shown that the production of high concentrations of acidic or basic electrolytic products do not occur (Prilutsky and Bakhir, 1997).

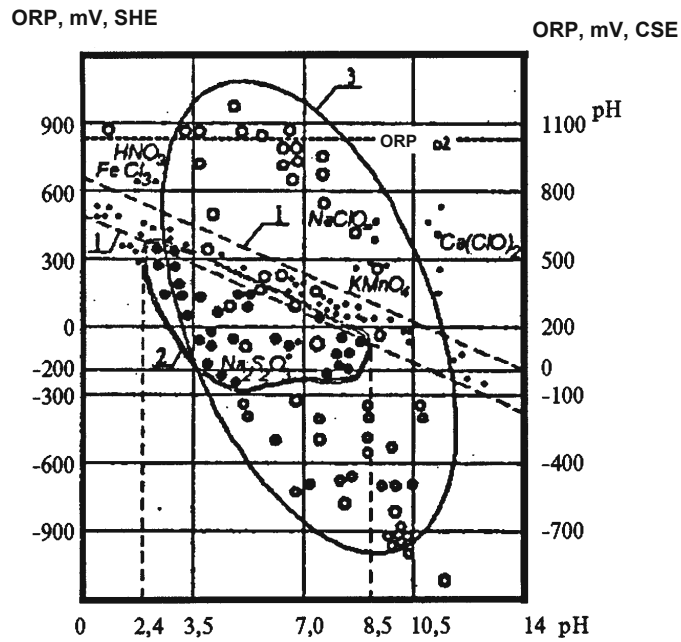

Legend: SHE – Standard Hydrogen electrode, CSE – Chloride Silver electrode.

Figure 10. Distribution of covariant pH and ORP (REDOX) values of inactivated organic and inorganic compounds in solution versus that of ECA solutions (Prilutsky and Bakhir, 1997).

Notwithstanding, the anodic and cathodic treatment of fresh, ultrafresh or even distilled water leads to the formation of anolyte or catholyte solutions that have heightened pH and exaggerated REDOX values relative to that of equivalent non-activated acidic and alkaline solutions respectively. This process is associated with the formation of covariant pH and REDOX combinations in the Anolyte and Catholyte solutions which cannot be replicated with conventional chemical reagents in the absence of exposure to electrochemical activation (Prilutsky and Bakhir, 1997).

1.5.5.7 Attributes of ECA solutions.

Common or potable water which is subjected to magnetism, sonic treatment, agitation, exposure to light, heating or cooling, and freezing with subsequent melting, attains new qualities which affect the kinetics of chemical reactions occurring within it, as well as its dissolution and washing properties.

In an ECA solution, the dissolved molecules undergo considerable structural transformation for an extended period of time, and through relaxation, there is a progressive reduction in its reactive capacity until it reaches an equilibrium state. Since it is not possible to determine the exact nature of the thermodynamic disequilibrium of solutions in an electroactivated state, the quantification and qualification of the ECA phenomenon relies largely upon an indirect description, where the difference in net effect between non-activated and activated solutions is contrasted. The polar association of water molecules into clusters is predominantly due to the van der Waal's forces of attraction, and as this energy of association is largely negligible (8-20 kJ/mol), it cannot prevent the destruction of the aggregates of water molecules which occurs during electrochemical activation (Prilutsky and Bakhir, 1997).

Following the destruction of the water molecule aggregates, the aqueous medium becomes comprised of an increased proportion of water mono-molecules which have substantially heightened chemical reactivity. This feature manifests as a change in viscosity, diffusivity, heat conduction, electrical conductivity, catalytic activity, Oxidation-reduction balance, and surface tension (Bakhir, 1999).

1.5.5.8 Types of ECA Solutions

According to the inventor, the ECA solutions may be classified into four distinct various types:

- i) A - acidic anolyte
pH: <5,0
REDOX: $\geq +1200$ mV CSE
Active species: $\text{Cl}_2 > \text{HClO} > \text{HCl} > \text{HO}_2$

This solution is produced when there is no catholyte feedback or recirculation into the anodal chamber, and where there is a high degree of mineralisation (>5 g/l NaCl). Chlorine gas is evolved, the solution is highly oxidising. Both effluent products are mostly stable.

- ii) AN - neutral anolyte
 pH: 5,0 - 7,0
 REDOX: +700 → +900 mV
 Active species: $\text{HClO} > \text{ClO}_2, \text{ClO}^-, \text{O}_3 > \text{HO}\cdot, \text{HO}\cdot_2, \text{HO}^{\cdot-}, \text{H}_2\text{O}_2, {}^1\text{O}_2, \text{Cl}\cdot, \text{HClO}_2, \text{HO}\cdot, \text{O}\cdot$
 In the generation of this solution, some catholyte has been recirculated into the anodal chamber and the mineralisation is generally low (<3 g/l NaCl). Under these production conditions, the formation of highly reactive and unstable radical species will predominate.
- iii) ANK – neutral-alkaline anolyte
 pH: 7,2 - 8,2
 REDOX: +250 → +800 mV
 Active species: $\text{ClO}^- > \text{HClO} > \text{HO}\cdot_2, \text{HO}\cdot, \text{H}_2\text{O}_2, {}^1\text{O}_2, \text{Cl}^-$
 Under these conditions the majority of the catholyte produced is recirculated into the anodal chamber, resulting in a higher pH. The solution retains its oxidising properties and has similar properties to AN, but it displays a shorter period of activation.
- iv) K - electrically activated alkaline catholyte
 pH: >9,0
 REDOX: -700 → -820 mV
 Active species: $\text{NaOH}, \text{O}^{\cdot-}, \text{HO}\cdot_2, \text{HO}^{\cdot-}, \text{OH}^-, \text{OH}\cdot, \text{HO}_2^-, \text{O}^{2\cdot-}$
 This solution has a pH of 11-12 and is highly reducing. It is very active but the relaxation times are significantly shorter than that of the various Anolyte solutions ($t_{1/2} \leq 8$ hours).
- v) KN - electrically activated neutral catholyte
 pH: <9,0
 REDOX: -300 → -500 mV
 Active species: $\text{O}^{\cdot-}, \text{HO}\cdot_2, \text{HO}^{\cdot-}, \text{H}_2\text{O}_2, \text{H}\cdot, \text{OH}\cdot$
 (Prilutsky and Bakhir, 1997).

As mentioned previously, neither hydroxyl radical, superoxide, ozone nor chlorine dioxide could be detected in the freshly generated oxidant solutions during targeted ESR studies (Stan and Daeschel, 2005; Stan *et al.*, 2005). While Kimbrough *et al.*, (2006) confirmed the presence of hydrogen peroxide in both the anodal and cathodal solutions by colourimetric titration with ammonium molybdate and sodium thiosulphate, the analysis of the alkaline antioxidant cathodal solution with ESR similarly failed to detail the presence of any ROS during the abovementioned investigation. However while all of the studies readily confirmed the presence of both hypochlorous acid and hypochlorite molecules in a range of ECA solutions of differing pH values, until these and similar studies are standardised against a single reactor design type i.e. FEM, with directly comparable operation parameters, definitive conclusions as to the constituent composition of the electrolyzed oxidizing solutions relative to FEM derived solutions will remain questionable.

As with anolyte, the characteristics of catholyte can similarly be varied. Aside from chemical reagents, the catholyte solutions contain structural water clusters that are reduced in size to $\approx 5-6$ water molecules and these have been shown to readily permeate through biological tissue. The charge on these clusters is proposed to be due to the presence of a surrounding negatively charged electron cloud (Prilutsky, 1997).

The co-axial arrangement of the electrodes has been engineered so as to create an electrical charge gradient or electric double layer (EDL) equivalent to a gradient of millions of volts/cm at both the anodal and cathodal electrode surfaces (Prilutsky and Bakhr, 1997). During the period of exaggerated relaxation activity, the ECA solutions can be applied as a direct substitute for conventional chemical reagents and regimens. In contrast to these chemical reagents, the final ECA products revert to the benign equivalent of the initial pre-activation solution i.e. dilute brine. The rate of relaxation decay or reversion to the pre-electroactivated state will vary dependent on the solution type and may be as short as a few hours (Catholyte) or it may extend to several months under optimal storage conditions (Anolyte).

Following the initial reports on the unique activities of the solutions generated by the early prototypal devices, considerable refinement has been made toward the optimisation of the dimensions and composition of the constituents of these

electrolytic cells in order to achieve enhanced productivity, reliability and sustained economic efficiency (Bakir *et al.*, 1999)

1.5.5.9 ECA DEVICES

Currently the on-site ECA electrochemical systems may, depending on their field of application, be categorised as follows:

1. Devices for generating liquid and gaseous chlorine - On-site Chlorine Generators e.g. AQUACHLOR-type.
2. Devices for generating electrochemically activated mixed oxidant solutions e.g. STEL-type (Fig 9).
3. Devices for the treatment of drinking water e.g. EMERALD-type.

Table 2. Classification of ECA devices (Bakir, 1999).

Device type	Oxidant production capacity / hour	Salt usage per g of oxidant	Power consumption per hour
AQUACHLOR On-site chlorine generator	1000gm/hr	1.8 gm	3, 42 kw/hr
STEL On-site Mixed oxidant generator (Fig 11)	500gm/hr	1.0 gm	3,5 kw/hr
EMERALD* On-site water purifier	Nil *	Nil*	0.5-1 watt x hour/lit

* - The Emerald device uses electrolysis for the direct intra-reactor microbial elimination, removal of heavy metals and toxic organic compounds for the production of purified potable water. No brine is added and it produces an active oxidant concentration of 1-10 mg/l. The units are predominantly designed for house-hold use.

1.6 Conclusions

While water has systematically been regarded as a benign solvent or space-filler, its unique behaviour and distinctive physicochemical attributes, intrinsically facilitates its energetic manipulation. These features permit the creation of a diverse array of

previously unreported reagents with anomalous properties which exist exclusively in an electroactivated state.

The mechanisms of conventional brine electrolysis have been described in terms of predictable chemical pathways with quantifiable energetic exchanges. However the classical laws of thermodynamics have been shown to be substantially inadequate when it comes to describing the Electrochemically activated state. To this end, the energy dynamics of the ECA electrolyte solutions can really only be described by the results that these anomalous energy states effect when compared and contrasted against equivalent applications with non-electrochemically activated solutions.

While an extensive array of electrolysis reactor systems have been manufactured, most designs have been geared to the commercial production of chemical compounds. Outside of these large industrial electrolysis systems, a variety of scaled-down variants have also been reported to electrolyse dilute brine solutions to produce solutions with elevated REDOX. However, most of these solutions do not subscribe to the full extent or range of anomalous attributes that have been ascribed to the coaxial aligned reactor capability.

Thus the sustained generation of the anomalous electroactivated state has required the design and fabrication of the refined FEM reactor configuration. Aside from reactor design, the ECA technology also requires operation under narrowly defined limits of input quality and quantity. It is only through consistent adherence to these prescribed standard operating instructions that ECA solutions of reliably repeatable quality and performance capabilities can be produced.

Given that the original literature is highly theoretical and oftentimes speculative, the claims relating to the range of reactive radical species that are produced during the electroactivation process have been found to be wanting and recent investigations with sophisticated analyses have not been able to substantiate the original claims.

Notwithstanding, the elevated Oxidation-Reduction potential generated during the electroactivation process has been substantially corroborated by independent studies, and while the unique differentiating attributes of the ECA solutions relative to those of earlier electrolysis devices remains largely untested, a growing body of evidence would suggest that the coaxial reactor design has the capability to selectively manipulate the properties of water in dilute brine solutions.

1.7 References

Bakhr, V.M. (1999). Theoretical Aspects of Electrochemical Activation. Second International Conference. Electrochemical Activation in Medicine, Agriculture and Industry, Moscow

Bakhr, V.M. and Zadorozhny, Y.G. (1999a). FEM Flow-through Electrochemical Modular and RFE Reactor in Technical Electrochemical Systems. Second International Conference. Electrochemical Activation in Medicine, Agriculture and Industry. Moscow

Bakhr, V.M. and Zadorozhny, Y.G. (1999b). Technical Electrochemical Systems for generating products of the sodium chloride solution electrolysis. Second International Conference. Electrochemical Activation in Medicine, Agriculture and Industry. Moscow.

Bakhr, V.M., Zadorozhny, Y.G. and Barabash, T. (1999). Apparatus for Electrochemical treatment of water and/or water solutions. USPTO, US 5,871,623.

Bommaraju, T.V., Orosz, P.J. and Sokol, E.A. (2007). Electrochemistry Encyclopedia – Brine Electrolysis. <http://electrochem.cwru.edu/ed/encycl/>

Chaplin, M. (2007). Magnetic and Electric effects on water. London South Bank University. <http://www.lsbu.ac.uk/water/magnetic.htm>

Chernikov, F.R., Prilutsky, V.I. and Dmitriyev, N.N. (1999). Studying the properties of ECA solutions with the method of Dynamic Molecular Light Scattering. Second International Conference. Electrochemical Activation in Medicine, Agriculture and Industry, Moscow.

Curlin, L.C., Bommaraju, T.V. and Hansson, C.B. (1991). Alkali and Chlorine products. In: Kroschwitz, J.I., Howe-Grant, M. (Eds.) Kirk-Othmer Encyclopedia of Chemical Technology, Volume 1, 938-1025. Wiley and Sons, Inc. New York.

Diao, H.F., Li, X.Y., Gu, J.D., Shi, H.C. and Xie, Z.M. (2004). Electron microscopic investigation of the bactericidal action of electrochemical disinfection in comparison with chlorination, ozonation and Fenton reaction. *Process Biochemistry*, 39, 1421-1426.

Drost-Hansen, W. (1965). The occurrence and extent of Vicinal water, The state and movement of water in living organisms, 163-169. In: Symposia of the society of experimental biology, Number XIX, Cambridge University Press

Guentzel, J.L., Lam, K.L., Callan, M.A., Emmons, S.A. and Dunham, V.L. (2008). Reduction of bacteria on spinach, lettuce and surfaces in food service areas using neutral electrolysed oxidizing water. *Food Microbiology*. 25 (1), 36-41.

Hanaoka, K. (2001). Antioxidant effects of reduced water produced by electrolysis of sodium chloride solutions. *Journal of Applied Electrochemistry*. 31, 1307-1313.

Hennion, C. (2006). Catholyte Cleaning. Chemserve Laboratory, Chloorkop, SA. Unpublished report.

Hsu, S.-Y. (2003). Effects of water flow rate, salt concentration and water temperature on efficiency of an electrolyzed oxidizing water generator. *Journal of Food Engineering*. 60 (4), 469-473.

Hsu, S.-Y. (2005). Effects of flow rate, temperature and salt concentration on chemical and physical properties of electrolyzed oxidizing water. *Journal of Food Engineering*. 66, 171-176.

Kotz, J, and Purcell, K.F. (1991). Chemistry and Chemical Reactivity (2nd ed.), Saunder College Publishing, Holt, Rinehart and Winston, Inc.

Lehninger, A.L., (1975). Biochemistry - The molecular basis of cell structure and function (2nd ed.), Worth Publishers, N.Y.

Leonov, B. I., (1997). Electrochemical Activation of water and Aqueous solutions: Past, Present and Future. First International Symposium, Electrochemical Activation in Medicine, Agriculture and Industry – Summaries of Papers and Brief reports, Moscow.

Liao, L.B., Chen, W.M. and Xiao, X.M. (2007). The generation and inactivation mechanism of oxidation-reduction potential of electrolysed oxidising water. *Journal of Food Engineering*, 78, 1326-1332.

Ludemann, H.-D. (1993). Thermodynamic and dynamic properties of water. In E. Westhof (Ed.). *Water and Biological Macromolecules* (Chapter 2). CRC Press.

Marais, J.T. and Brözel, V, S. (1999). Electro-chemically activated water in dental unit water lines. *British Dental Journal*. 187 (2), 154-158.

Marais, J.T. (2000). Investigations into the applications of electrochemically activated water in dentistry. *SA Dental Journal*. 55 (7), 381-386.

Prilutsky, V.I. and Bakhir, V.M. (1997). Electrochemically Activated Water: Anomalous properties, Mechanism of biological action, All Russian Scientific Research and Experimental Institute of Medical Engineering (VNIIMT), UDK 621.357:541.13.

Prilutsky, V.I. (1997). Review and comments on the Japanese version of the antioxidant action of cathode-activated water. First International Symposium, Electrochemical Activation in Medicine, Agriculture and Industry, Summary supplement of papers and brief reports. Moscow.

Rowe, C.D. (2001). ECASOL Notes. Commissioned report. Battelle Research Institute.

Sampson, M.N. and Muir, A.V.G. (2002). Not all super-oxidised waters are the same. *Journal of Hospital Infection*. 52 (3), 227-228.

Savage, H.F.J. (1993). Water Structure. In E. Westhof (Ed.), *Water and Biological Macromolecules* (Chapter 1). CRC Press.

Shirahata, S., Kabayama, S., Nakano, M., Miura, T., Kusumoto, K., Gotoh, M., *et al.*, (1997). Electrolyzed-Reduced water scavenges active oxygen species and protects DNA from Oxidative damage. *Biochemical and Biophysical Research Communications*. Volume 234, 269-274.

Schwartz, A.T. (1997). The wonder of water. *Chemistry in context*. (Chapter 5). (2nd ed.). Wm C Brown Publishers, Iowa.

Sperelakis, N. (1995). *Cell Physiology Source Book*. Academic Press, California.

Stan, S.D. and Daeschel, M.A. (2005). 5,5-Dimethyl-2-pyrrolidone-*N*-oxyl formation in Electron Spin Resonance studies of electrolyzed NaCl solution using 5,5-dimethyl-1-pyrroline-*N*-oxide as a spin trapping agent. *Journal of Agricultural and Food Chemistry*. 53, 4906-4910.

Stan, S.D., Woods, J.S. and Daeschel, M.A. (2005). Investigation of the presence of OH radicals in electrolyzed NaCl solution by Electron Spin Resonance Spectroscopy. *Journal of Agricultural and Food Chemistry*. 53, 4901-4905.

Stumm, W. and Morgan, J.J. (1996). *Aquatic Chemistry: Chemical equilibria and rates in natural waters*, (3rd ed.). John Wiley and Sons Inc. NY.

Stryer, L. (1981). *Biochemistry*, (2nd ed.). W.H. Freeman and Company, San Francisco.

Suzuki, T., Noro, T., Kawamura, Y., Fukunaga, K., Watanabe, M., Ohta, M., *et al.*, (2002). Decontamination of Aflatoxin-forming fungus and elimination of aflatoxin mutagenicity with electrolysed NaCl anolyte solution. *Journal of Agricultural and Food Chemistry*. 50, 633-641.

Tomilov, A.P. (2002). Electrochemical Activation: a new trend in Applied Electrochemistry. *“Zhizn & Bezopasnost” Life and Safety Magazine*, 302-307.

White, G.C. (1992). *The handbook of Chlorination and Alternative Disinfectants*. (3rd ed.). Van Nostrand Reinhold. NY.

Wyllie, G. (1965). Kinetic Theory and transport in ice and water. In: *The state and movement of water in living organisms – Symposia of the society of experimental biology*. Number XIX, 33-52. Cambridge University Press.

Zenin, S.V. (1999). On the mechanism of water activation, 155-156. Second International Symposium, *Electrochemical Activation in Medicine, Agriculture and Industry*, Moscow.

Zinkevich, V., Beech, I.B., Tapper, R.C. and Bogdarina, I. (2000). The effect of super-oxidised water on *Escherichia coli*. *Journal of Hospital Infection*. 46 (2), 153-156.

Zubay, G.L., Parson, W.W. and Vance, D.E. (1995). *Principles of Biochemistry*. Wm C Brown Communications Inc., IA.